

APPLICATION NOTE

K2 Capture Service with Pathfire and DG FastChannel

Roger Crooks, Product Marketing

March 2009



The K2 Capture Service offers a complete, fast, and cost-effective file-based workflow for distributed syndication content that eliminates time-consuming transcoding and QA of material.

Grass Valley K2 Capture Service

Product Overview

The K2 Capture Service application adds a new capability to the K2 video sever system that enables broadcasters to transfer content from their Pathfire DMG and DG FastChannel Spot Box directly into a K2 media client system without transcoding, manual intervention, or additional equipment. This application runs directly on the K2 media client and is the result of collaborative development between Grass Valley™, Pathfire, and DG FastChannel to fully support stations' transition to HD programming.

This capability delivers significant speed advantages to your workflow. HD media will transfer at speeds of 5 to 10 times faster than real-time. In comparison to file transcoding methods that are typically much slower than real-time, the direct transfer approach with K2 media clients will enable significantly faster import speeds, thus shortening the time staff must spend initiating, monitoring, and checking the material. For example, syndicated content that is 30 minutes in length transfers in as little as 3-5 minutes using this new service—versus up to an hour using a transcoding methodology.

The Grass Valley K2 media client solution requires less capital to deploy, fewer components to manage, and works at speeds expected of file-based environments and workflows.

Product Description

The K2 Capture Service is a software application that is available with K2 system software V3.2.74 or later. The K2 Capture Service works specifically with the Pathfire DMG server and the DG FastChannel Spot Box for SD and HD content. The process involves moving MPEG-2 files located on “catch servers” directly into the K2 media client.

How It Works – Enhanced Workflows

The K2 Capture Service uses two slightly different processes for Pathfire and DG file transfer workflows. Both of these processes work with a K2 standalone media client or a K2-SAN.

Pathfire Workflow

For Pathfire content, material is “pushed” to the K2 media client. The push is initiated by the Pathfire DMG server from either the user interface (manually) or by automation through the Pathfire DMG Automation Connect software. The Pathfire content is composed of several smaller segments that are transferred to the K2 media client individually and then “joined” with an EDL that the Pathfire DMG server sends to the K2 media client. Once joined, these segments appear to automation systems as one continuous clip that can then be timed and QC'd using standard automation tools.

DG Workflow

For DG FastChannel, the K2 media client “pulls” material by monitoring the contents of the DG FastChannel Spot Box server. When a house ID is assigned to a spot on the Spot Box, the K2 Capture Service application will transfer the

material to the K2 media client. This process can be set up so that the content is placed in a folder location where it can be QC'd before being made visible to automation systems. The two diagrams on the next page depict configurations for SAN or standalone environments.

Workflow Policies

In most workflow models, automation systems are responsible for initiating the transfer of syndicated assets to the server, as well as tracking which spots were imported. K2 Capture Service allows policies to be established for deleting content, moving content, and handling problems that require content to be resent.

Deletes – Clips can be deleted via automation, asset management, or manually through the catch server interface and the K2 AppCenter software. Most content will have specific usage rights that are generally known by the traffic department. If a spot is deleted or moved, K2 Capture Service will not import it again from the catch server.

Moves – Once a clip has been imported and verified, it can be copied elsewhere. This process is best handled by automation systems that track the locations of content for layout.

Resends – The K2 Capture Service application will display an error when content that already exists on the server is resent. The original imported content must be deleted before it is resent to the K2 media client. If the original content exists on other K2 media clients or devices, all instances of that version should be deleted, or else two versions of the same clip will reside in your system.

K2 Capture Service Configurations

Entry-Level Systems

An entry-level system consists of a catch server and a K2 system (standalone client or SAN). Moving content from the catch server to the K2 server is manual, with the user initiating the transfer from the catch server interface. With DG systems, the user checks for the appropriate ISCI code and assigns a house ID which will initiate the transfer to the K2 media client. With Pathfire systems, the user moves the material to the K2 media client from the Pathfire DMG interface.

Automation Systems

Automation systems receive schedules from the traffic department. They monitor the catch server for the appropriate content and move the material to the K2 media client. If there are multiple K2 media clients available, the automation system will move the content to the required K2 servers for playout. Automation systems will generally also provide an application for quality checks.

Automation systems will receive usage rights from the traffic department and an asset management system will delete all content from the system as required.

K2 SAN Configuration

On a K2 SAN, files are transferred (via FTP) to the K2 storage. Once transferred, any K2 media client can play back the content.

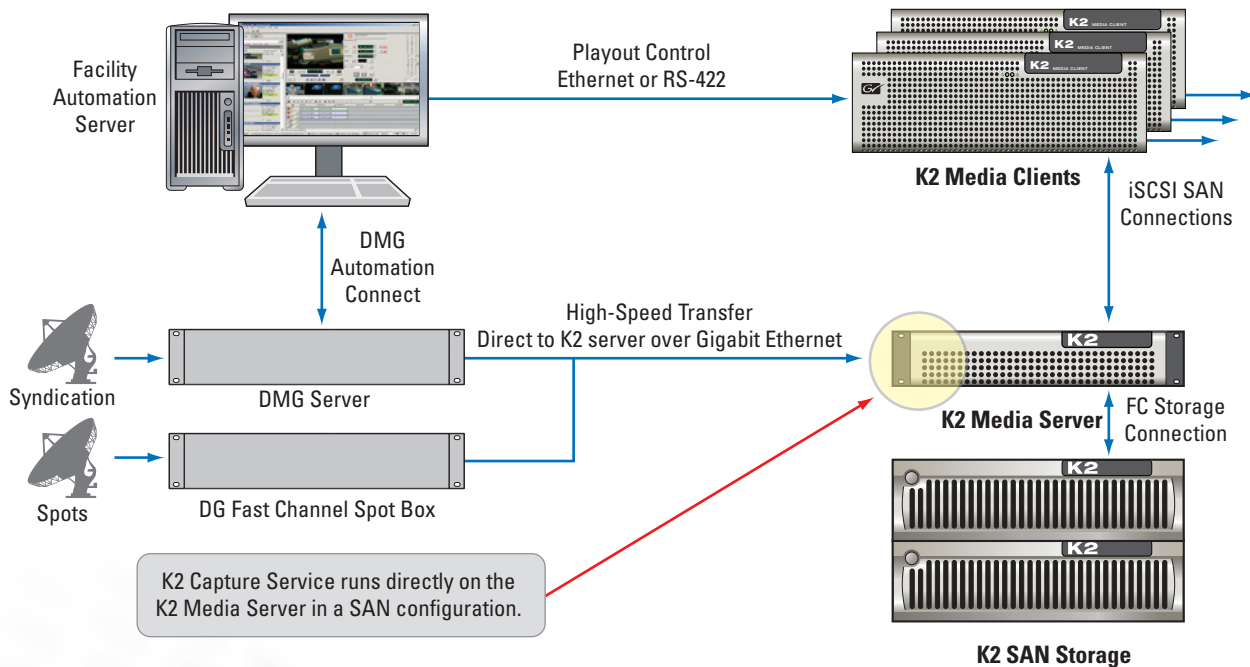

Figure 1 – Content is distributed over various networks into a catch server. Content is then directly transferred to the K2 system without transcoding resulting in 5-10 times faster than real-time transfers.

K2 Capture Service Configurations (cont.)

K2 Standalone Configurations

On a system with one or more standalone K2 media clients, content is transferred (via FTP) to one K2 media client and then distributed to other K2 media clients for playout as needed.

Enhanced Features – Metadata support

A key aspect of the K2 Capture Service application ensures that all of the important metadata (such as closed captioning, time-code, clip length, etc.) associated with the files are preserved.

Closed Captioning

For HD content from Pathfire and DG systems, all closed caption information is preserved in HD as a CEA-708 packet in ANC data space. If the content is down-converted to SD, the closed caption information is preserved in EIA-608 format on line 21 along with any V-chip information.

Notes on SD Support

For SD content, closed captions in the VBI can be stored compressed (similar to the video) or as uncompressed VBI lines. The K2 media client will handle both with no problem by storing the digital data in the SD ANC.

For compressed VBI, the K2 media client will extract the closed caption waveform and decode it into digital data and store it in the SD ANC.

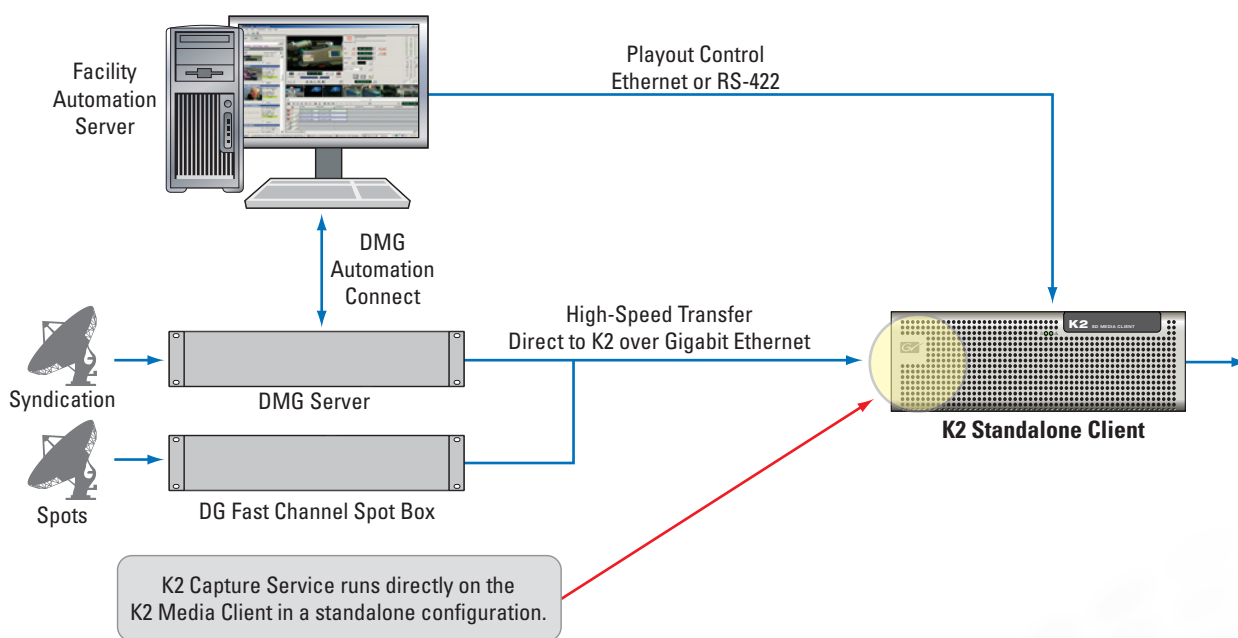

Figure 2 – Operation in a standalone system is the same as in a SAN as shown in Figure 1.

Connecting to Automation Systems

The last step in the workflow is to register the new content with the automation system.

Pathfire Solutions

The Pathfire Digital Media Gateway Automation Connect software registers (available directly from Pathfire) new content with the automation system. This process transfers clip metadata to the automation system's database, enabling frame-accurate timing and retention of other metadata such as air dates and ratings.

Interfaces with the following vendors are being adapted to work with the K2 Capture Service application – additional vendors are constantly being added. Check with your automation system vendor for details.

Crispin – Digital Transfer Agent (DTA) Pathfire – automates the link between the Pathfire DMG Server and K2 media clients with the K2 Capture Service application for a fully automated, on-air presentation.

Utilizing Pathfire's Automation Connect product, the Crispin DTA provides a seamless solution to automatically move programs to K2 media clients and prepare them for air. The DTA periodically reviews the Pathfire DMG server for new programs. The Crispin system issues commands via Automation Connect that trigger the DMG server to push the programs to K2 media clients where they are directly imported (without the need for transcoding). Metadata is simultaneously retrieved from the Pathfire DMG and stored. The required programs now reside on the video server, assembled and complete with program segment timing data in Crispin automation, ready for play-to-air.

For more information:
www.crispincorp.com

Telephone: +1-919-845-7744

Floral – ShowTimer Pathfire – The existing ShowTimer interface to the Pathfire system works transparently and without modification with the K2 Capture Service application, speeding up and simplifying the file transfer process. Station-created Pathfire orders within Floral's ShowTimer Order Entry "traffic" application inform the ShowTimer system which and when shows are expected to appear on the Pathfire DMG server(s). When shows are available, the ShowTimer system activates, via an interface to Pathfire's Automation Connect module, the transfer of the shows to a destination K2 system (standalone client or SAN). The same interface delivers the show's segment timing metadata, which is imported in to Floral's media database. The shows can then be QC'd for content and timing within the Floral MediaTimer application, before the Floral Asset Management application (MediaMaster) distributes the shows within the station (to other servers or archive), then clear the shows for air.

For more information:
www.floral.com

Telephone: +1-352-372-8326

Sundance Digital – Digital Delivery Management System – DDMS integrates tightly with Pathfire systems and controls the movement and renaming of media from the Pathfire DMG server to the station's broadcast server. In addition, the Pathfire system sends frame-accurate program timing information. This data is automatically applied to the media element in the Sundance database, resulting in a fully segmented program without the manual labor normally required. The integration of program metadata saves station operators a great deal of time and manpower. DDMS works seamlessly with the K2 Capture Service application to facilitate these transfers.

For more information:
www.avid.com/sundance.asp

Telephone: +1-800-949-2843 (option #1)

VCI Solutions – autoXe MC – autoXe uses business rules to completely automate the process of moving and renaming content from digital delivery servers within a facility. The business rules that you define instruct the automation system as to how and when to transfer and rename the content, placing it directly on the K2 play-to-air media client. This eliminates manual processes required to complete the ingest activities.

For all content processed in this manner the metadata associated with the content is automatically entered into the automation database, eliminating the need for manual steps to complete the prep process. This results in an optimized workflow, dramatically reducing the time and manpower required in both the ingest and the media preparation processes.

For more information:
www.vcisolutions.com

Telephone: +1-512-837-3737

Harris Corporation – Harris ADC Automation offers the Automatic Ingest (AI) system, which provides automated or manual transfers from Pathfire and K2 media clients. AI uses the Pathfire Automation Connect protocol to retrieve content metadata, initiate and monitor transfer requests, and specify the house ID to use during the transfer. AI accepts a wide range of dub list formats for automated or manual content transfers. AI users can preview program material metadata prior to the transfer process and add to it or update it before storing it within the ADC database. AI provides a single location to view incoming digital content and monitor, transfer progress with simple search capabilities to find specific content quickly and easily. Once the program content has been transferred to the K2 media clients it is ready for air with program title, segment, and timing information automatically placed within the ADC database. ADC's file transfer applications, GMT and Intelligent Media Mover, support workflows to move/copy the newly created K2 file to other K2 media clients or archive devices.

For more information:
www.broadcast.harris.com/products/automation/

Telephone: +1-800-231-9673

For additional information, please contact your local Grass Valley Sales Representative.

Case Study – WAGM-TV8 – Presque Isle, Maine

WAGM receives syndicated content from Pathfire for various long-form syndicated programs. They use the Sundance Titan Automation system with the Digital Delivery Management System (DDMS) and wanted to automate the process of getting the syndicated programs on air with minimal manual intervention. They purchased a standalone K2-SD-04, 4-channel SD MPEG/DV media client along with the K2 Capture Service application.

Their workflow is as follows:

- Content is received into the Pathfire DMR server
- The Sundance DDMS extracts the frame-accurate timing information from the Pathfire DMR and triggers the K2 Capture Service
- K2 Capture Service transfers the syndicated files from the Pathfire DMR, stitches them together, and saves the program on the K2 media client (as described above)
- The Sundance automation system schedules the playout on the K2 media client according to traffic and inserts commercials frame-accurately

“Grass Valley has a product that does Pathfire transfers with a Sundance interface that cuts down the amount of time involved to move Pathfire delivered syndicated shows by more than 80 percent.”

Gordon Wark, President and GM
WAGM-TV8

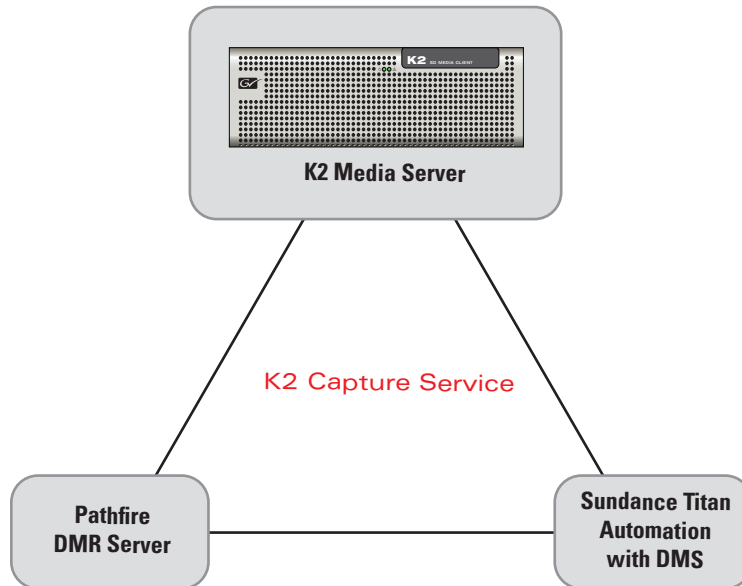

SALES

Local and regional sales contacts can be found by visiting
www.grassvalley.com/sales

SUPPORT

Local and regional support contacts can be found by visiting
www.grassvalley.com/support