



grass valley

A **BELDEN** BRAND

MV-831 MULTIVIEWER

INTEGRATED MULTIVIEWER FOR SIRIUS 830 ROUTER

User Manual

Issue 1 Revision 1

17 April 2020

www.grassvalley.com

FCC Compliance

In order to comply with FCC/CFR47: Part 15 regulations, it is necessary to use high-quality, triple-screened Media or Monitor cable assemblies with integrated ferrite suppression at both ends.

Patent Information

This product may be protected by one or more patents.

For further information, please visit: www.grassvalley.com/patents/

Copyright and Trademark Notice

Copyright © 2020, Grass Valley Canada. All rights reserved.

Belden, Belden Sending All The Right Signals, and the Belden logo are trademarks or registered trademarks of Belden Inc. or its affiliated companies in the United States and other jurisdictions. Grass Valley and MV-831 are trademarks or registered trademarks of Grass Valley Canada. Belden Inc., Grass Valley Canada, and other parties may also have trademark rights in other terms used herein.

Terms and Conditions

Please read the following terms and conditions carefully. By using MV-831 Multiviewer documentation, you agree to the following terms and conditions.

Grass Valley hereby grants permission and license to owners of MV-831 Multiviewer to use their product manuals for their own internal business use. Manuals for Grass Valley products may not be reproduced or transmitted in any form or by any means, electronic or mechanical, including photocopying and recording, for any purpose unless specifically authorized in writing by Grass Valley.

A Grass Valley manual may have been revised to reflect changes made to the product during its manufacturing life. Thus, different versions of a manual may exist for any given product. Care should be taken to ensure that one obtains the proper manual version for a specific product serial number.

Information in this document is subject to change without notice and does not represent a commitment on the part of Grass Valley.

Warranty information is available from the Legal Terms and Conditions section of Grass Valley's website.

(See www.grassvalley.com.)

Title	MV-831 Multiviewer User Manual
Part Number	RMV3 MV831UM Issue 1 Revision 1
Revision	17 April 2020

About this Manual

Thank you for purchasing your new MV-831 Multiviewer from Grass Valley, a Belden brand.

This MV-831 Multiviewer User Manual describes how to install, configure and operate the MV-831 Multiviewer in a Grass Valley Sirius 830 router. It provides any relevant safety information.

Refer to the Sirius 830 Router Installation Manual for details on how to unpack, install and test a Sirius 830 router. Refer to the Sirius 800 Router User Manual for router details. Some of the safety warnings and cautions given the Sirius router manuals are repeated in this MV-831 User Manual and are provided herein for information.

After reading this user manual, if you have any questions regarding the installation and setup of your product, please contact Grass Valley customer support.

Related Documents

The following Grass Valley manuals are related documents:

Document		Description
User Manual:	MV-8 Series Multiviewer	User manual for the multiviewer 'engine' within MV-8X0/8X1 Multiviewer products.
User Manual:	Sirius 800 Router	User manual for Sirius 800 series routers.
Installation Manual:	Sirius 830	Installation manuals for Sirius 830 router.

Important Safety Information

This section provides important safety guidelines for operators and service personnel. Specific warnings and cautions appear throughout the manual where they apply. Please read and follow this important information, especially those instructions related to the risk of electric shock or injury to persons.

Symbols and Their Meanings



Indicates that dangerous high voltage is present within the equipment enclosure that may be of sufficient magnitude to constitute a risk of electric shock.



Indicates that the user, operator or service technician should refer to the product manuals for important operating, maintenance, or service instructions.



This is a prompt to note the fuse rating when replacing fuses. The fuse referenced in the text must be replaced with one having the ratings indicated.



Identifies a protective grounding terminal which must be connected to earth ground prior to making any other equipment connections.

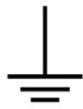

Identifies an external protective grounding terminal which may be connected to earth ground as a supplement to an internal grounding terminal.



Indicates that static sensitive components are present, which may be damaged by electrostatic discharge. Use anti-static procedures, equipment and surfaces during servicing.



Indicates that the equipment has more than one power supply cord, and that all power supply cords must be disconnected before servicing to avoid electric shock.



The presence of this symbol in or on Grass Valley equipment means that it has been tested and certified as complying with applicable Underwriters Laboratory (UL) regulations and recommendations for USA.



The presence of this symbol in or on Grass Valley equipment means that it has been tested and certified as complying with applicable Canadian Standard Association (CSA) regulations and recommendations for USA/Canada.



The presence of this symbol in or on Grass Valley equipment means that it has been tested and certified as complying with applicable Underwriters Laboratory (UL) regulations and recommendations for USA/Canada.



The presence of this symbol in or on Grass Valley equipment means that it has been tested and certified as complying with applicable Intertek Testing Services regulations and recommendations for USA/Canada.



The presence of this symbol in or on Grass Valley product means that it complies with all applicable European Union (CE) directives.



The presence of this symbol in or on Grass Valley product means that it complies with safety of laser product applicable standards.

Warnings



A warning indicates a possible hazard to personnel, which may cause injury or death. Observe the following general warnings when using or working on this equipment:

- Appropriately listed/certified mains supply power cords must be used for the connection of the equipment to the rated mains voltage.
- This product relies on the building's installation for short-circuit (over-current) protection. Ensure that a fuse or circuit breaker for the rated mains voltage is used on the phase conductors.
- Any instructions in this manual that require opening the equipment cover or enclosure are for use by qualified service personnel only.
- Do not operate the equipment in wet or damp conditions.
- This equipment is grounded through the grounding conductor of the power cords. To avoid electrical shock, plug the power cords into a properly wired receptacle before connecting the equipment inputs or outputs.

- Route power cords and other cables so they are not likely to be damaged. Properly support heavy cable bundles to avoid connector damage.
- Disconnect power before cleaning the equipment. Do not use liquid or aerosol cleaners; use only a damp cloth.
- Dangerous voltages may exist at several points in this equipment. To avoid injury, do not touch exposed connections and components while power is on.
- High leakage current may be present. Earth connection of product is essential before connecting power.
- Prior to servicing, remove jewelry such as rings, watches, and other metallic objects.
- To avoid fire hazard, use only the fuse type and rating specified in the service instructions for this product, or on the equipment.
- To avoid explosion, do not operate this equipment in an explosive atmosphere.
- Use proper lift points. Do not use door latches to lift or move equipment.
- Avoid mechanical hazards. Allow all rotating devices to come to a stop before servicing.
- Have qualified service personnel perform safety checks after any service.

Cautions



A caution indicates a possible hazard to equipment that could result in equipment damage. Observe the following cautions when operating or working on this equipment:

- This equipment is meant to be installed in a restricted access location.
- When installing this equipment, do not attach the power cord to building surfaces.
- Products that have no on/off switch, and use an external power supply must be installed in proximity to a main power outlet that is easily accessible.
- Use the correct voltage setting. If this product lacks auto-ranging power supplies, before applying power ensure that each power supply is set to match the power source.
- Provide proper ventilation. To prevent product overheating, provide equipment ventilation in accordance with the installation instructions.
- Do not operate with suspected equipment failure. If you suspect product damage or equipment failure, have the equipment inspected by qualified service personnel.
- To reduce the risk of electric shock, do not perform any servicing other than that contained in the operating instructions unless you are qualified to do so. Refer all servicing to qualified service personnel.
- This unit may have more than one power supply cord. Disconnect all power supply cords before servicing to avoid electric shock.
- Follow static precautions at all times when handling this equipment. Servicing should be done in a static-free environment.
- To reduce the risk of electric shock, plug each power supply cord into separate branch circuits employing separate service grounds.

Electrostatic Discharge (ESD) Protection



Electrostatic discharge occurs when electronic components are improperly handled and can result in intermittent failure or complete damage adversely affecting an electrical circuit. When you remove and replace any card from a frame always follow ESD-prevention procedures:

- Ensure that the frame is electrically connected to earth ground through the power cord or any other means if available.
- Wear an ESD wrist strap ensuring that it makes good skin contact. Connect the grounding clip to an *unpainted surface* of the chassis frame to safely ground unwanted ESD voltages. If

no wrist strap is available, ground yourself by touching the *unpainted* metal part of the chassis.

- For safety, periodically check the resistance value of the antistatic strap, which should be between 1 and 10 megohms.
- When temporarily storing a card make sure it is placed in an ESD bag.
- Cards in an earth grounded metal frame or casing do not require any special ESD protection.

Battery Handling



This product may include a backup battery. There is a danger of explosion if the battery is replaced incorrectly. Replace the battery only with the same or equivalent type recommended by the manufacturer. Dispose of used batteries according to the manufacturer's instructions. Before disposing of your Grass Valley equipment, please review the *Disposal and Recycling Information* at:

http://www.grassvalley.com/assets/media/5692/Take-Back_Instructions.pdf

Cautions for LCD and TFT Displays



Excessive usage may harm your vision. Rest for 10 minutes for every 30 minutes of usage.

If the LCD or TFT glass is broken, handle glass fragments with care when disposing of them. If any fluid leaks out of a damaged glass cell, be careful not to get the liquid crystal fluid in your mouth or skin. If the liquid crystal touches your skin or clothes, wash it off immediately using soap and water. Never swallow the fluid. The toxicity is extremely low but caution should be exercised at all times.

Mesures de sécurité et avis importants

La présente section fournit des consignes de sécurité importantes pour les opérateurs et le personnel de service. Des avertissements ou mises en garde spécifiques figurent dans le manuel, dans les sections où ils s'appliquent. Prenez le temps de bien lire les consignes et assurez-vous de les respecter, en particulier celles qui sont destinées à prévenir les décharges électriques ou les blessures.

Signification des symboles utilisés



Signale la présence d'une tension élevée et dangereuse dans le boîtier de l'équipement ; cette tension peut être suffisante pour constituer un risque de décharge électrique.



Avertit l'utilisateur, l'opérateur ou le technicien de maintenance que des instructions importantes relatives à l'utilisation et à l'entretien se trouvent dans la documentation accompagnant l'équipement.



Invite l'utilisateur, l'opérateur ou le technicien de maintenance à prendre note du calibre du fusible lors du remplacement de ce dernier. Le fusible auquel il est fait référence dans le texte doit être remplacé par un fusible du même calibre.



Identifie une borne de mise à la terre de protection. Il faut relier cette borne à la terre avant d'effectuer toute autre connexion à l'équipement.



Identifie une borne de mise à la terre externe qui peut être connectée en tant que borne de mise à la terre supplémentaire.



Signale la présence de composants sensibles à l'électricité statique et qui sont susceptibles d'être endommagés par une décharge électrostatique. Utilisez des procédures, des équipements et des surfaces antistatiques durant les interventions d'entretien.



Le symbole ci-contre signifie que l'appareil comporte plus d'un cordon d'alimentation et qu'il faut débrancher tous les cordons d'alimentation avant toute opération d'entretien, afin de prévenir les chocs électriques.



La marque UL certifie que l'appareil visé a été testé par Underwriters Laboratory (UL) et reconnu conforme aux exigences applicables en matière de sécurité électrique en vigueur au Canada et aux États-Unis.



La marque C-CSA-US certifie que l'appareil visé a été testé par l'Association canadienne de normalisation (CSA) et reconnu conforme aux exigences applicables en matière de sécurité électrique en vigueur au Canada et aux États-Unis.



La marque C-UL-US certifie que l'appareil visé a été testé par Underwriters Laboratory (UL) et reconnu conforme aux exigences applicables en matière de sécurité électrique en vigueur au Canada et aux États-Unis.



La marque ETL Listed d'Intertek pour le marché Nord-Américain certifie que l'appareil visé a été testé par Intertek et reconnu conforme aux exigences applicables en matière de sécurité électrique en vigueur au Canada et aux États-Unis.



Le marquage CE indique que l'appareil visé est conforme aux exigences essentielles des directives applicables de l'Union européenne en matière de sécurité électrique, de compatibilité électromagnétique et de conformité environnementale.



Le symbole ci-contre sur un appareil Grass Valley ou à l'intérieur de l'appareil indique qu'il est conforme aux normes applicables en matière de sécurité laser.

Avertissements



Les avertissements signalent des conditions ou des pratiques susceptibles d'occasionner des blessures graves, voire fatales. Veuillez vous familiariser avec les avertissements d'ordre général ci-dessous :

- Un cordon d'alimentation dûment homologué doit être utilisé pour connecter l'appareil à une tension de secteur de 120 V CA ou 240 V CA.
- La protection de ce produit contre les courts-circuits (surintensités) dépend de l'installation électrique du bâtiment. Assurez-vous qu'un fusible ou un disjoncteur pour 120 V CA ou 240 V CA est utilisé sur les conducteurs de phase.
- Dans le présent manuel, toutes les instructions qui nécessitent d'ouvrir le couvercle de l'équipement sont destinées exclusivement au personnel technique qualifié.

- N'utilisez pas cet appareil dans un environnement humide.
- Cet équipement est mis à la terre par le conducteur de mise à la terre des cordons d'alimentation. Pour éviter les chocs électriques, branchez les cordons d'alimentation sur une prise correctement câblée avant de brancher les entrées et sorties de l'équipement.
- Acheminez les cordons d'alimentation et autres câbles de façon à ce qu'ils ne risquent pas d'être endommagés. Supportez correctement les enroulements de câbles afin de ne pas endommager les connecteurs.
- Coupez l'alimentation avant de nettoyer l'équipement. Ne pas utiliser de nettoyeurs liquides ou en aérosol. Utilisez uniquement un chiffon humide.
- Des tensions dangereuses peuvent exister en plusieurs points dans cet équipement. Pour éviter toute blessure, ne touchez pas aux connexions ou aux composants exposés lorsque l'appareil est sous tension.
- Avant de procéder à toute opération d'entretien ou de dépannage, enlevez tous vos bijoux (notamment vos bagues, votre montre et autres objets métalliques).
- Pour éviter tout risque d'incendie, utilisez uniquement les fusibles du type et du calibre indiqués sur l'équipement ou dans la documentation qui l'accompagne.
- Ne pas utiliser cet appareil dans une atmosphère explosive.
- Présence possible de courants de fuite. Un raccordement à la masse est indispensable avant la mise sous tension.
- Après tout travail d'entretien ou de réparation, faites effectuer des contrôles de sécurité par le personnel technique qualifié.

Mises en garde



Les mises en garde signalent des conditions ou des pratiques susceptibles d'endommager l'équipement. Veuillez vous familiariser avec les mises en garde ci-dessous :

- L'appareil est conçu pour être installé dans un endroit à accès restreint.
- Au moment d'installer l'équipement, ne fixez pas les cordons d'alimentation aux surfaces intérieures de l'édifice.
- Les produits qui n'ont pas d'interrupteur marche-arrêt et qui disposent d'une source d'alimentation externe doivent être installés à proximité d'une prise de courant facile d'accès.
- Si l'équipement n'est pas pourvu d'un modules d'alimentation auto-adaptables, vérifiez la configuration de chacun des modules d'alimentation avant de les mettre sous tension.
- Assurez une ventilation adéquate. Pour éviter toute surchauffe du produit, assurez une ventilation de l'équipement conformément aux instructions d'installation.
- N'utilisez pas l'équipement si vous suspectez un dysfonctionnement du produit. Faites-le inspecter par un technicien qualifié.
- Pour réduire le risque de choc électrique, n'effectuez pas de réparations autres que celles qui sont décrites dans le présent manuel, sauf si vous êtes qualifié pour le faire. Confiez les réparations à un technicien qualifié. La maintenance doit se réaliser dans un milieu libre d'électricité statique.
- L'appareil peut comporter plus d'un cordon d'alimentation. Afin de prévenir les chocs électriques, débrancher tous les cordons d'alimentation avant toute opération d'entretien.
- Veillez à toujours prendre les mesures de protection antistatique appropriées quand vous manipulez l'équipement.
- Pour réduire le risque de choc électrique, branchez chaque cordon d'alimentation dans des circuits de dérivation distincts utilisant des zones de service distinctes.

Protection contre les décharges électrostatiques (DES)



Une décharge électrostatique peut se produire lorsque des composants électroniques ne sont pas manipulés de manière adéquate, ce qui peut entraîner des défaillances intermittentes ou endommager irrémédiablement un circuit électrique. Au moment de remplacer une carte dans un châssis, prenez toujours les mesures de protection antistatique appropriées :

- Assurez-vous que le châssis est relié électriquement à la terre par le cordon d'alimentation ou tout autre moyen disponible.
- Portez un bracelet antistatique et assurez-vous qu'il est bien en contact avec la peau. Connectez la pince de masse à une *surface non peinte* du châssis pour détourner à la terre toute tension électrostatique indésirable. En l'absence de bracelet antistatique, déchargez l'électricité statique de votre corps en touchant une surface métallique *non peinte* du châssis.
- Pour plus de sécurité, vérifiez périodiquement la valeur de résistance du bracelet antistatique. Elle doit se situer entre 1 et 10 mégohms.
- Si vous devez mettre une carte de côté, assurez-vous de la ranger dans un sac protecteur antistatique.
- Les cartes qui sont reliées à un châssis ou boîtier métallique mis à la terre ne nécessitent pas de protection antistatique spéciale.

Manipulation de la pile



Ce produit peut inclure une pile de sauvegarde. Il y a un risque d'explosion si la pile est remplacée de manière incorrecte. Remplacez la pile uniquement par un modèle identique ou équivalent recommandé par le fabricant. Disposez des piles usagées conformément aux instructions du fabricant. Avant de vous séparer de votre équipement Grass Valley, veuillez consulter les *informations de mise au rebut et de recyclage* à :

http://www.grassvalley.com/assets/media/5692/Take-Back_Instructions.pdf

Précautions pour les écrans LCD et TFT



Regarder l'écran pendant une trop longue période de temps peut nuire à votre vision. Prenez une pause de 10 minutes, après 30 minutes d'utilisation.

Si l'écran LCD ou TFT est brisé, manipulez les fragments de verre avec précaution au moment de vous en débarrasser. veillez à ce que le cristal liquide n'entre pas en contact avec la peau ou la bouche. En cas de contact avec la peau ou les vêtements, laver immédiatement à l'eau savonneuse. Ne jamais ingérer le liquide. La toxicité est extrêmement faible, mais la prudence demeure de mise en tout temps.

Environmental Information

European (CE) WEEE directive.

This symbol on the product(s) means that at the end of life disposal it should not be mixed with general waste.



Visit www.grassvalley.com for recycling information.

Grass Valley believes this environmental information to be correct but cannot guarantee its completeness or accuracy since it is based on data received from sources outside our company. All specifications are subject to change without notice.

If you have questions about Grass Valley environmental and social involvement (WEEE, RoHS, REACH, etc.), please contact us at environment@grassvalley.com.

Safety Information Continued

Lithium Batteries

Battery Warning

CAUTION

This equipment contains a lithium battery.
There is a danger of explosion if this is replaced incorrectly.
Replace only with the same or equivalent type.
Dispose of used batteries according to the manufacturer's
instructions.
Batteries **shall only** be replaced by trained service technicians.

Your Grass Valley equipment usually comes with at least one button battery located on the main printed circuit board. The batteries are used for backup and should not need to be replaced during the lifetime of the equipment.

Battery Disposal

Before disposing of your Grass Valley equipment, please remove the battery as follows:

- 1 Make sure the AC adapter / power Cord is unplugged from the power outlet.
- 2 Remove the protective cover from your equipment.
- 3 Gently remove the battery from its holder using a blunt instrument for leverage such as a screwdriver if necessary. In some cases the battery will need to be desoldered from the PCB.
- 4 Dispose of the battery and equipment according to your local environmental laws and guidelines.

WARNING

- Be careful not to short-circuit the battery by adhering to the appropriate safe handling practices.
- Do not dispose of batteries in a fire as they may explode.
- Batteries may explode if damaged or overheated.
- Do not dismantle, open or shred batteries.
- In the event of a battery leak, do not allow battery liquid to come in contact with skin or eyes.
- Seek medical help immediately in case of ingestion, inhalation, skin or eye contact, or suspected exposure to the contents of an opened battery.

Laser Safety - Fiber Output SFP and QSFP Modules Warning

LASER SAFETY



The average optical output power does not exceed 0 dBm (1mW) under normal operating conditions. Unused optical outputs should be covered to prevent direct exposure to the laser beam.

Even though the power of these lasers is low, the beam should be treated with caution and common sense because it is intense and concentrated. Laser radiation can cause irreversible and permanent damage of eyesight. Please read the following guidelines carefully:

- Make sure that a fiber is connected to the board's fiber outputs before power is applied. If a fiber cable (e.g. patchcord) is already connected to an output, make sure that the cable's other end is connected, too, before powering up the board.
- **Do not** look in the end of a fiber to see if light is coming out. The laser wavelengths being used are totally invisible to the human eye and can cause permanent damage. Always use optical instrumentation, such as an optical power meter, to verify light output.

Rear Panel Module Handling

IMPORTANT

Take care when handling the MV-830-RP rear panel module:

The rear panel module has some sharp, pointed locating pins. The pins are exposed until the component is fitted into the router frame.

Safety and EMC Standards

This equipment complies with the following standards:

Safety Standards



Information Technology Equipment - Safety Part 1

EN60950-1: 2006

Safety of Information Technology Equipment Including Electrical Business Equipment.

UL1419 (4th Edition)

Standard for Safety – Professional Video and Audio equipment (UL file number E193966)

EMC Standards

This unit conforms to the following standards:

EN55032:2015 (Class A)

Electromagnetic Compatibility of multimedia equipment - Emission requirements

EN61000-3-2:2014 (Class A)

Electromagnetic Compatibility - Limits for harmonic current emissions

EN61000-3-3:2013

Electromagnetic Compatibility - Limits of voltage changes, voltage fluctuations and flicker

EN55103-2:2009 (Environment E2)

Electromagnetic Compatibility, Product family standard for audio, video, audio-visual and entertainment lighting control apparatus for professional use. Part 2. Immunity

WARNING

This equipment is compliant with Class A of CISPR 32. In a residential environment this equipment may cause radio interference.

FCC / CFR 47:Part 15 (Class A)

Federal Communications Commission Rules Part 15, Subpart B

Caution to the user that changes or modifications not expressly approved by the party responsible for compliance could void the user's authority to operate the equipment.

Note: This equipment has been tested and found to comply with the limits for a Class A digital device, pursuant to part 15 of the FCC Rules. These limits are designed to provide reasonable protection against harmful interference when the equipment is operated in a commercial environment.

This equipment generates, uses, and can radiate radio frequency energy and, if not installed and used in accordance with the instruction manual, may cause harmful interference to radio communications.

Operation of this equipment in a residential area is likely to cause harmful interference in which case the user will be required to correct the interference at his own expense.

EMC Performance of Cables and Connectors

Grass Valley products are designed to meet or exceed the requirements of the appropriate European EMC standards. In order to achieve this performance in real installations it is essential to use cables and connectors with good EMC characteristics.

All signal connections (including remote control connections) shall be made with screened cables terminated in connectors having a metal shell. The cable screen shall have a large-area contact with the metal shell.

SIGNAL/DATA PORTS

For unconnected signal/data ports on the unit, fit shielding covers. For example, fit EMI blanking covers to SFP+ type ports; and fit 75 Ω RF terminators to BNC type ports

COAXIAL CABLES

Coaxial cables connections (particularly serial digital video connections) shall be made with high-quality double-screened coaxial cables such as Belden 8281 or BBC type PSF1/2M and Belden 1694A (for 3Gbps).

D-TYPE CONNECTORS

D-type connectors shall have metal shells making good RF contact with the cable screen. Connectors having "dimples" which improve the contact between the plug and socket shells, are recommended.

toc

Table of Contents

Front Cover	i
FCC Compliance	ii
Patent Information	ii
About this Manual	iii
Battery Handling	vi
Safety Information Continued	xi
Lithium Batteries	xi
Laser Safety - Fiber Output SFP and QSFP Modules Warning	xii
Rear Panel Module Handling	xii
Safety and EMC Standards	xiii
Safety Standards	xiii
EMC Standards	xiii
1 Product Overview	1
Benefits of an Integrated Multiviewer	2
Typical User Applications	2
Features	2
MV-831 Components	4
Order Codes	5
MV-831 Module Inputs and Outputs	6
Functional	7
Integration into Sirius 830 Router	9
Sirius 830 Router Frame Requirements	9
Fitting into Router Frame	9
Router Controller Configuration	10
MV-831 Monitoring Modes	11
MV-831 Default Monitoring Mode (24 Outputs and 24 Inputs)	12
Router Configuration Settings for Monitoring Mode	13
MV-831 General Monitoring Mode	15
General Mode Examples	16
Software and Firmware Compatibility Matrix	18
Multiviewer Terminology	18
MV-831 Set up	18
Hardware Installation	18
Router Power Supply Considerations	18
Initial Multiviewer Configuration	19
Configuration Screens (RollCall Templates)	19
Video Wall Design	19
Maintenance	20
Multiviewer Licensing	20
Multiviewer Software Upgrade	20
MV-831H.264 Streaming Out	20
2 MV-831 Hardware Modules	21
Double-width Front Module (MV-831-MB)	22
Front LEDs, Connectors and Switches	23

- Status LEDs..... 24
- DIP switches..... 25
- Engineering controls and connectors 25
- Double-width Rear Panel (MV-830-RP)..... 26
 - Connectors..... 28
 - Rear Panel LEDs 29
 - LTC and GPIO Connector Pin-outs..... 32
 - Example: Driving LEDs from the GPI Outputs 34

- 3 Hardware Installation35**
 - Unpacking 36
 - Initial Checks and Actions..... 37
 - Router Model Check..... 37
 - Router Frame Check 37
 - Power Checks 37
 - Router Module Type and Input/Output Port Type..... 38
 - Fitting of Video SFPs to MV-831 Rear Panel 38
 - Identifying Modules and Slots in the Sirius 830 Router 40
 - Removal and then Fitting of Modules 45
 - Removal Preliminaries 45
 - Module Removal Procedure..... 46
 - Fitting Preliminaries 48
 - Module Fitting Procedure..... 49
 - Connecting Cables 53
 - MV-831 Module Booting 55

- Appendix A Specification57**
 - Physical/Electrical 57
 - Dimensions 57
 - Inputs..... 58
 - Outputs..... 59
 - Router Outputs..... 59
 - Multiviewer Head Display Outputs 59
 - TV Standards 61
 - Reference 61
 - GPI and LTC 61
 - Ethernet Rear Panel Connectors..... 62
 - Unused Rear Panel Connectors..... 62
 - Software Versions 62
 - Router Controller Configuration Items..... 63

- Appendix B Router Slot Information65**

- Contact Us67**
 - Grass Valley Technical Support..... 67
 - Corporate Head Office 67

1

1 Product Overview

The Grass Valley MV-831 brings a wealth of previously unseen capabilities in an integrated multiviewer. One or more MV-831 Multiviewer modules can be fitted into a Sirius 830 router. The MV-831 is available either as an option on a new Sirius 830 router from the factory or as an option to be installed in the field.

An MV-831 is a compact module, combining:

- a Sirius 830 video 24-input module; and
- a Sirius 830 video 24-output module;
- plus a powerful 48-input multiviewer.

A single MV-831 can drive up to 12 multiviewer display monitors, showing up to 48 different video input images.

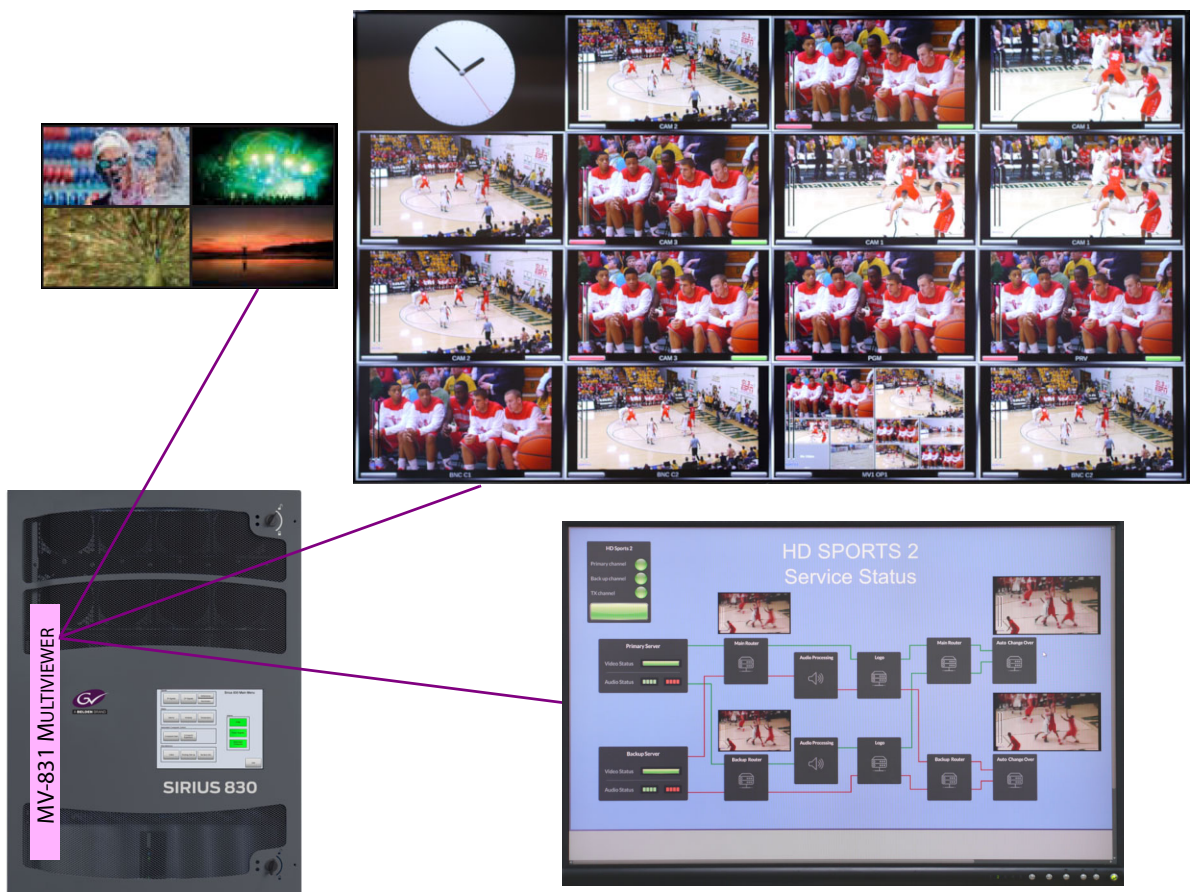

Fig. 1-1: MV-831 Multiviewer Video Walls and Screens

MV-831 Integrated Multiviewer for Sirius 830 Router =

24 Router Video Inputs + 24 Router Video Outputs + Powerful Multiviewer

Benefits of an Integrated Multiviewer

The benefits of an integrated multiviewer include:

- Flexible multiviewer routing configurations.
- No loss of router inputs or outputs.
- No additional space required.
- No signal cabling, simplified installation.
- Reduced power consumption and cooling requirements.

Typical User Applications

The MV-831 Multiviewer is ideal for any user application that requires single or multiple displays. For example:

- Playout control rooms.
- Multi-channel playout.
- Studio galleries.
- OB trucks.
- Post-production suites.
- Signal lines monitoring areas.

Features

With the development of advanced technology within the MV-831 Multiviewer, Grass Valley can offer some unique, powerful multiviewer features:

Integrates into Sirius 830 systems:

- Provides 24 router inputs and 24 router outputs.
- Monitors 48 video signals while maintaining router inputs and outputs.
 - Accesses up to 24 router video outputs on the MV-831.
 - Accesses up to 24 router video inputs on the MV-831.
 - Accesses up to 288 router video sources (i.e. any router input).
- Up to 12-off MV-831s can be fitted per host router, see Table 1-1.

Table 1-1: MV-831 in Sirius 800 Series Routers

Sirius 800 Router	Number of fitted MV-831s
Sirius 830	12-off Maximum
Sirius 840	N/A
Sirius 850	N/A

Note 1: The MV-831 Multiviewer *only* fits into Sirius 830 routers.

Multiviewer Monitoring (per MV-831 module):

- Monitor up to 48 video signals from the host router (inputs or outputs).
(SD-SDI/ HD-SDI/ 3G-SDI /Quad-link 3G-SDI for UHD.)
- High image quality: Input de-interlacing, scaling.

Advanced broadcast media monitoring:

- Media biometric signature generation for all 48 multiviewer inputs.
 - Low-bandwidth video and audio signatures streamed.
 - Applications include: Lip sync, Channel mapping detection, Confidence monitoring, identification and comparison.
- HDR support.

Up to 12 multiviewer head display outputs per MV-831:

- 3G 1080p or HD 720p.
- UHD using four 3G-SDI outputs to provide a UHD quad-link.
- Multiviewer display outputs:
 - 4 display outputs on baseline MV-831 model.
 - Expandable to up to 12 display outputs per MV-831, enabled with additional MV-831 licenses.
- Head display outputs use flexible SFP modules.
 - Mixture of 3G SDI dual-coax, dual-fiber, or single HDMI outputs.

Total screen layout flexibility:

- Flexible video tile arrangements.
- Adjustable layering, transparencies and fine-positioning.
- 48 internal scalers: One per MV-831 multiviewer input.
- Display status and alarms from external devices.
- Drag and Drop objects onto the video wall layout.
- Additionally display web pages, automation playlists, device status screens etc.

Flexible alarm capability:

- Monitoring of video, audio and metadata with alarm notification.
- Intelligent monitoring of external devices with configurable on-screen alarms.
- Control and acknowledgment of alarms from hardware- and soft-panels.

Streaming Out of Multiviewer Input-Copies (License-enabled):

- MV-831 multiviewer inputs can be H.264-encoded to create streamed copies of inputs which can then be streamed out over IP.
- Streams can be viewed on a desktop PC with appropriate software.
See the 'MV-8 Series Multiviewer' user manual.

Note: **Viewing H.264-encoded video IP streams with GV Orbit:**

Grass Valley GV Orbit Lite can be used to form a PC-based streamed video monitoring wall (ideal for secondary monitoring applications). Input H.264 video IP streams, from one or more MV-8X0/8X1 modules, may be displayed on a PC monitor, showing live video, audio levels and alarms.

MV-831 Components

The MV-831 Integrated Multiviewer option consists of some hardware modules fitted into front and rear slots of a Sirius 830 router frame. The MV-831 module may be purchased already fitted into a new Sirius 830 router from Grass Valley, or they may be bought separately as a hardware upgrade option for an existing Sirius 830 router. One or more MV-831s may be fitted to the router.

Note: [Identifying Modules and Slots in the Sirius 830 Router](#), on page 40, shows which Sirius router slots are used for the MV-831.

Note: When fitting the MV-831 into an existing router, the relevant router slots may already be used by other Sirius 800 modules. In this case, those modules need to be removed as part of the MV-831 installation (see Sirius 800 User Manual).
If in doubt, do contact Grass Valley Support.

One MV-831 comprises:

- A double-width front module (MV-831-MB).
- A double-width rear module (MV-830-RP, the same as used on an MV-830 Multiviewer).

Table 1-2 lists MV-831 component parts. (Full order codes are listed in [Order Codes](#), on page 5.)

Table 1-2: List of Front Modules and Rear Panels etc. required for an MV-831

Component	Qty	Comment
MV-831-MB	1 off	MV-831 Main Module (Front)
MV-830-RP	1 off	MV-831's rear panel is the same as the one used on MV-830. No SFP video modules are fitted.
SFP video modules	up to 6-off per MV-831	For head display outputs. Mixture of video SFP modules and SFP blanking plugs. (The combination depends on MV-831 licensing option purchased.) SFPs may be bought separately. SFP types: <ul style="list-style-type: none">• SM-TT-3G (SDI, dual transmit).• ST31ST31-3 (Fiber).• FC1-HDMI2 (HDMI).• SFPBLANK (Blanking plug).

Order Codes

Table 1-3: MV-831 Order Codes

Order Code	Description
MV-831-MB	MV-831 main module (a double-width, front module), includes a license for 4 display outputs. (Display outputs 1 to 4. I.e. enough for one 4K output display.)
MV-830-RP	The MV-831 multiviewer uses the same rear panel as on the MV-830. (A double-width rear module, with SFP cages for accepting SFP <i>video</i> output modules for display outputs.) Note: SFP video output modules must be ordered separately.
Additional Licenses:	
MV-831-H264	Factory-fitted option to provide the capability to stream out H.264 copies of multiviewer inputs.
Additional Display Outputs:	For additional head display outputs. This comprises supplied codes to enable more outputs:
MV-831-OP56	License to enable outputs 5 and 6.
MV-831-OP78	License to enable outputs 7 and 8.
MV-831-OP910	License to enable outputs 9 and 10.
MV-831-OP112	License to enable outputs 11 and 12. Note: SFP video output modules for additional head display outputs must be ordered separately.
SFP Modules (Video):	
	Per SFP module: <ul style="list-style-type: none"> • 2-off SDI outputs (coaxial or fiber); or • 1-off HDMI output.
CC-TTH-3G-N	Multiviewer HD-BNC Dual Output SFP module. Grass Valley module number SM-TT-3G.
ST31ST31-3	Multiviewer Fiber Dual Output SFP module (1310 nm, single mode).
FC1-HDMI1	HDMI single output SFP module.
SFP Module (Ethernet):	
FGAEY 1GBE-SFP	Ethernet 1GbE SFP.
SFP Module (Blank):	
SFPBLANK	SFP blanking plug (dust and EMC cover).

MV-831 Module Inputs and Outputs

The MV-831 Multiviewer is a double-width Sirius 830 router module which occupies an input slot and adjacent output slot of a host Sirius 830 router frame (a slot-pair). It replaces an input and an output module, providing functionality of a multiviewer plus an input and output module.

It has external connections at its rear panel and also connects internally to the host router. The host router provides power and timing signals.

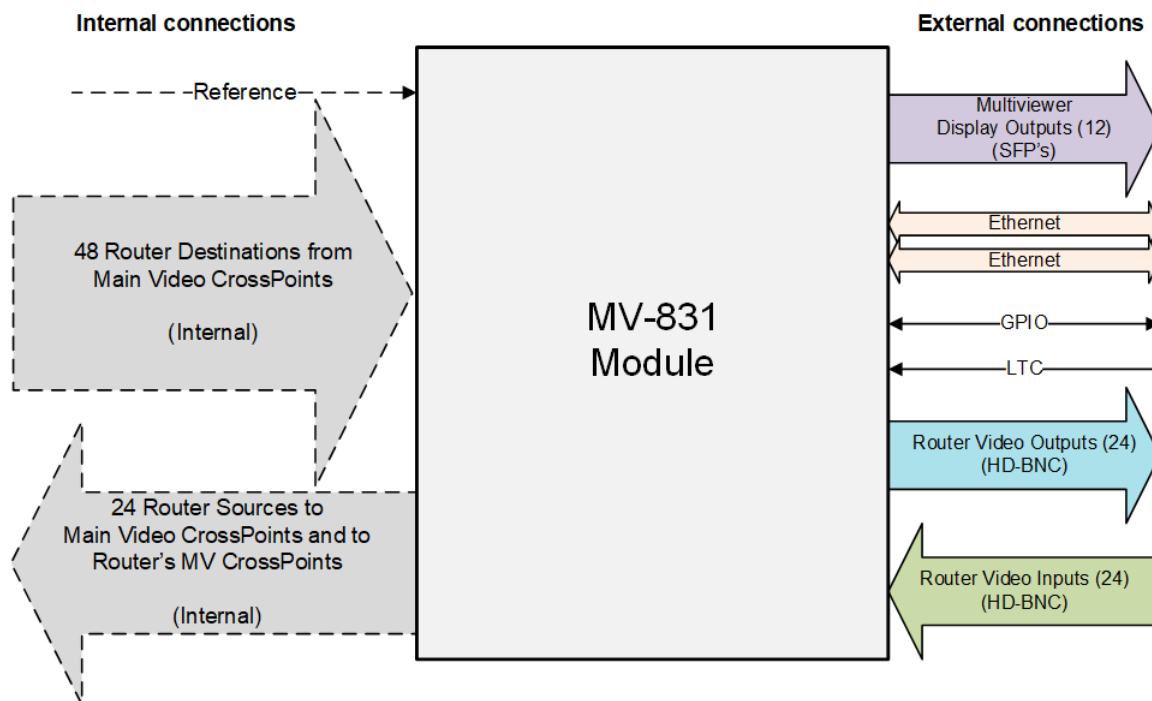

Fig. 1-2: MV-831 Module - Main Input and Output Signals

Figure 1-2 shows the main MV-831 input and output signal connections:

External Connections:

- 24 router video inputs, HD-BNC.
- 24 router video outputs, HD-BNC.
- Multiviewer display outputs - Up to 6-off SFPs, providing up to 12 outputs for monitor display screens. Outputs available in SDI coax, fiber or HDMI, and are Quad-link 4K-capable.
Note: There is only one HDMI connector per HDMI SFP. Thus, there are only up to 6 HDMI display outputs.
- Ethernet connections - 2-off 1G Ethernet ports.
For communications traffic and H.264 streaming out of multiviewer inputs.
- LTC and GPIO.

Internal Connections:

- 48 internal video signals *from* router crosspoint destinations (inputs to MV-831). I.e. 24 signals from the main router crosspoint and 24 from second (redundant) router crosspoint.
- 24 internal video signals *to* the router crosspoints (outputs from the MV-831). These are router video sources.
- Video reference information from the host router frame.

Functional

The MV-831 Multiviewer combines the functionality of a router input module, a router output module and a multiviewer. The MV-831 replaces a pair of input and output modules in a Sirius 830 frame.

*MV-831 = a Router Video Input Module
+ a Router Video Output Module
+ a Powerful MV-8 Series Multiviewer*

Note:

Sirius 830 and MV-831 Inputs monitoring:

The MV-831 module's router input video signals may be monitored by the 'on-module' MV-8 Series Multiviewer and by all the input monitoring facilities of the host Sirius 830 router frame:

- Input/Output Monitoring Sirius 830 router module; and
- Multiviewer Crosspoint Sirius 830 router module.

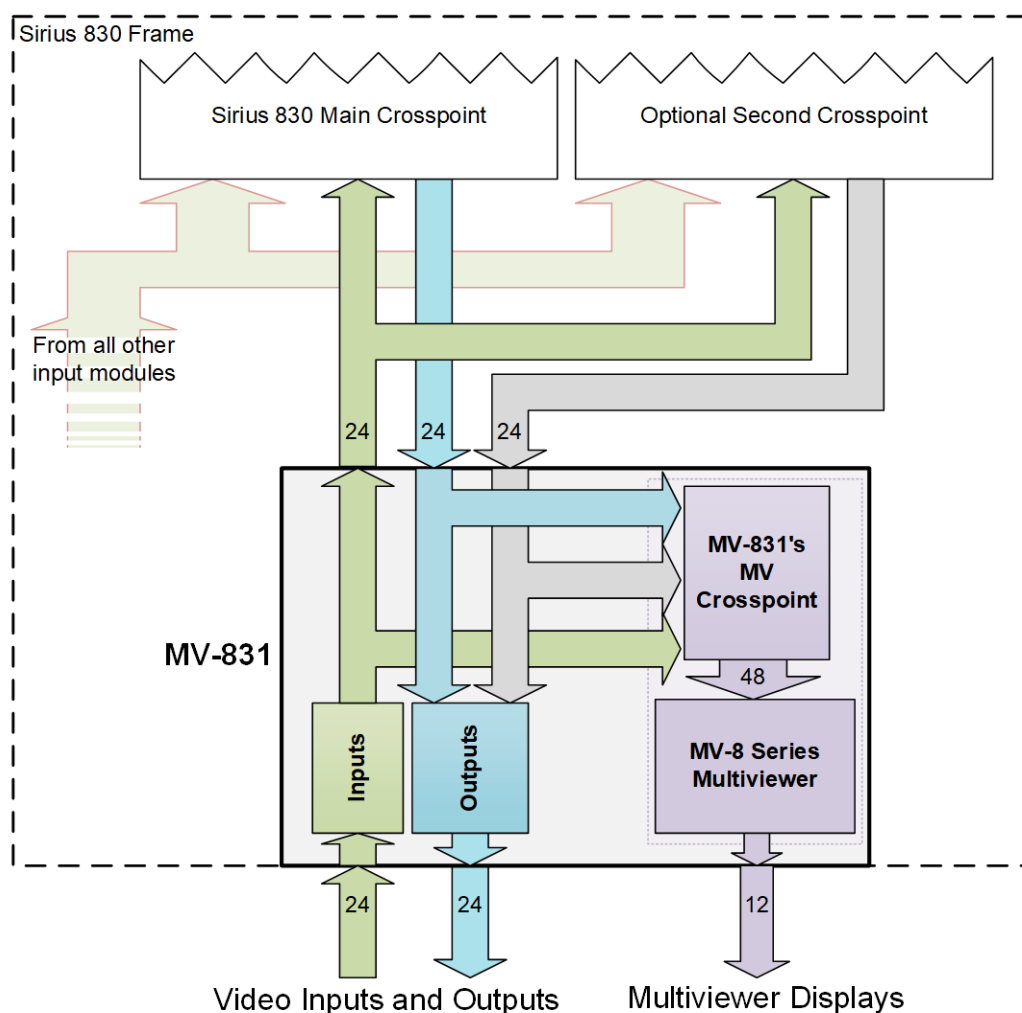

Fig. 1-3: MV-831 Functional Block Diagram

Figure 1-3 shows a high level diagram of an MV-831 in a Sirius 830 frame. The internal input and output video signal paths through the MV-831 are shown to and from the router crosspoints.

Router inputs pass through the module to the router main crosspoint(s). Router outputs for the module are derived from the main and second (redundant) crosspoints, as on a router output module. The internal video connections to/from the router crosspoint permit full routing of the MV-831 inputs/outputs. The normal router source and router destination ports for the router frame slots occupied by the MV-831 are used.

The MV-831's multiviewer block displays 48 video signals from a small, local 'MV crosspoint' which is fed from video input and output signals on the MV-831 module. 48 video signals are selected for the multiviewer according to the multiviewer monitoring mode (see [MV-831 Monitoring Modes](#), on page 11).

Integration into Sirius 830 Router

Sirius 830 Router Frame Requirements

To fit a MV-831 Multiviewer into a Sirius 830 router, requirements for the router frame are:

- Mark 3 Sirius router frame.
- Sufficient router power supply capacity: Contact Grass Valley for advice.
- 2-off adjacent front input-output module slots.
- 2-off corresponding rear module slots.

And, depending on the intended use case, a second (redundant) video crosspoint may also be required.

Fitting into Router Frame

Figure 1-4a shows a top-level functional diagram of a host Sirius 830 router. Figure 1-4b shows the interleaved nature of Sirius 830 input and output modules in the router frame.

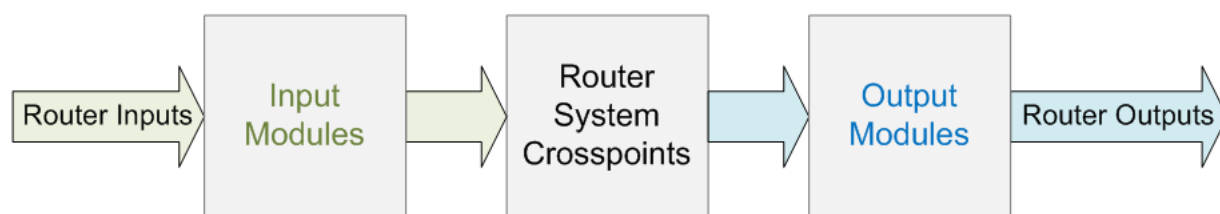

a) Router - Top Level Functional Diagram

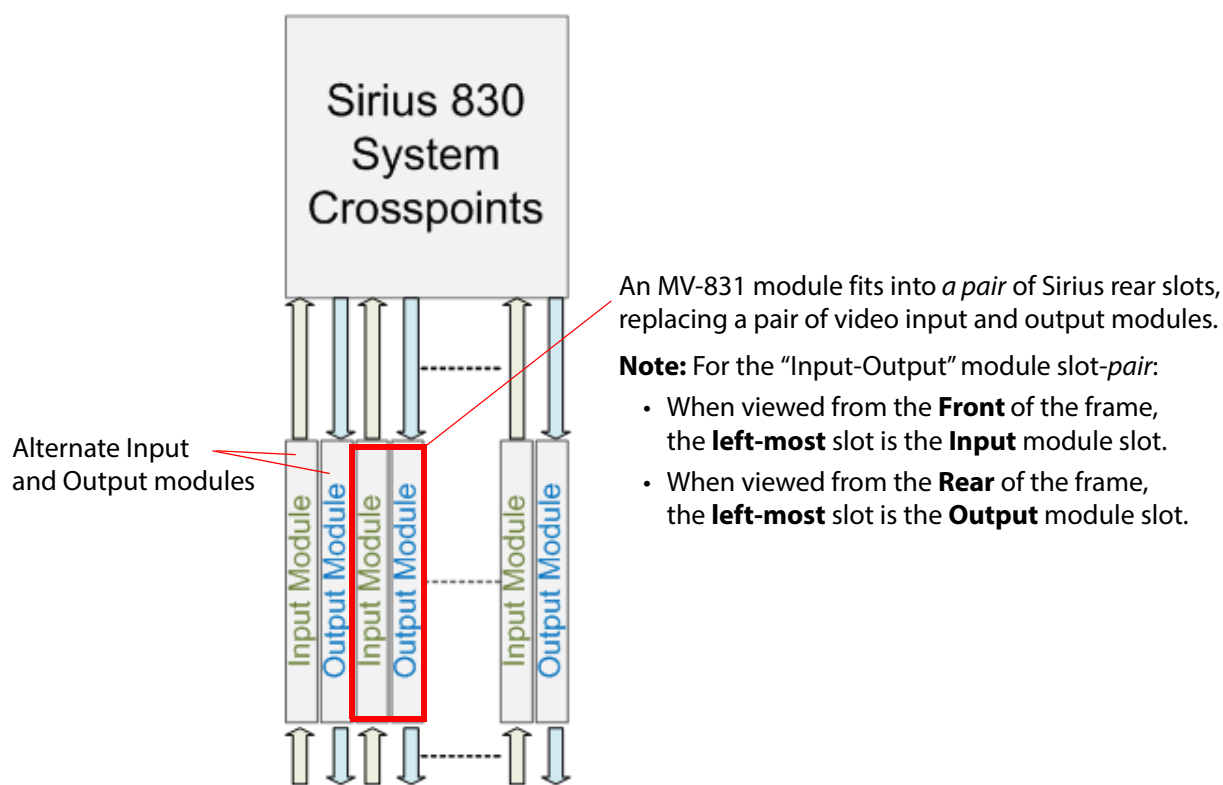

b) Sirius 830 Router Frame - Architectural Top Level Diagram

Fig. 1-4: MV-831 in Sirius 830 Router:

a) Top Level Functional Diagram.

b) Architectural Top Level Diagram, with an Input-Output 'slot-pair' highlighted.

A MV-831 Multiviewer module fits into a *pair* of adjacent Sirius 830 input/output module slots (both front and rear). More than one MV-831 may be fitted into a Sirius 830 router.

(See [Identifying Modules and Slots in the Sirius 830 Router](#), on page 40, for router front and rear module slot details.)

Router Controller Configuration

From a router controller perspective, the MV-831 module's input/output functionality appears to a host Sirius 830 router like a standard video input module and a standard video output module. And this input/output functionality is under the control of the host router and is unchanged from normal input/output router modules. The MV-831 module's multiviewer functionality, however, is essentially a separate sub-system.

The MV-831 has access to its own router inputs and router destinations. In particular, each destination may be configured to either a) have routing redundancy, or b) provide up to 24-off extra destinations to each MV-831 module. It is configured in the host router's router controller configuration. This determines the mixture of router sources, destination outputs and MV-831 module inputs monitored by the MV-831's multiviewer.

From a router controller configuration point of view, an MV-831:

- has a specific input/output port type;
- has specific module types;
- has access to internal Sirius 830 video crosspoint destinations in the second (redundant) crosspoint (i.e. destination numbers above 288); and
- can use the internal LTC signal.

(See [Router Controller Configuration Items](#), on page 63, Table A-15.)

The host router's controller configuration needs to be modified to accommodate all the fitted MV-831 Multiviewers and any extra external crosspoint control required.

Router controller configurations differ. The controller configuration of any host router is tailored to the system it is part of and to that particular router's application. Router controller configurations are created, edited and managed with the Grass Valley WorkBench software tool.

For instructions on modifying a router controller configuration, contact Grass Valley Support.

Note:

Second (redundant) video crosspoint module - Exposing crosspoints to external control:

Strictly speaking, not all of a host router's redundant crosspoint destinations need to be exposed for external control; only those used directly by MV-831(s) need to be given a control interface (or added to an existing control interface).

However, all redundant crosspoints may be exposed for external control because any crosspoints of the second crosspoint module that are used for redundancy are systematically unaffected by external control.

Setting up all of the crosspoints of the second (redundant) crosspoint module for external control simplifies host router controller configuration when adding various MV-831s.

MV-831 Monitoring Modes

When an MV-831 is fitted to a Sirius 830 router, the multiviewer block within the MV-831 module has access to the following signals:

- 24 router video outputs.
- 24 router video signals from the router's optional second (redundant) crosspoint.
- 24 router video inputs.

See Figure 1-5.

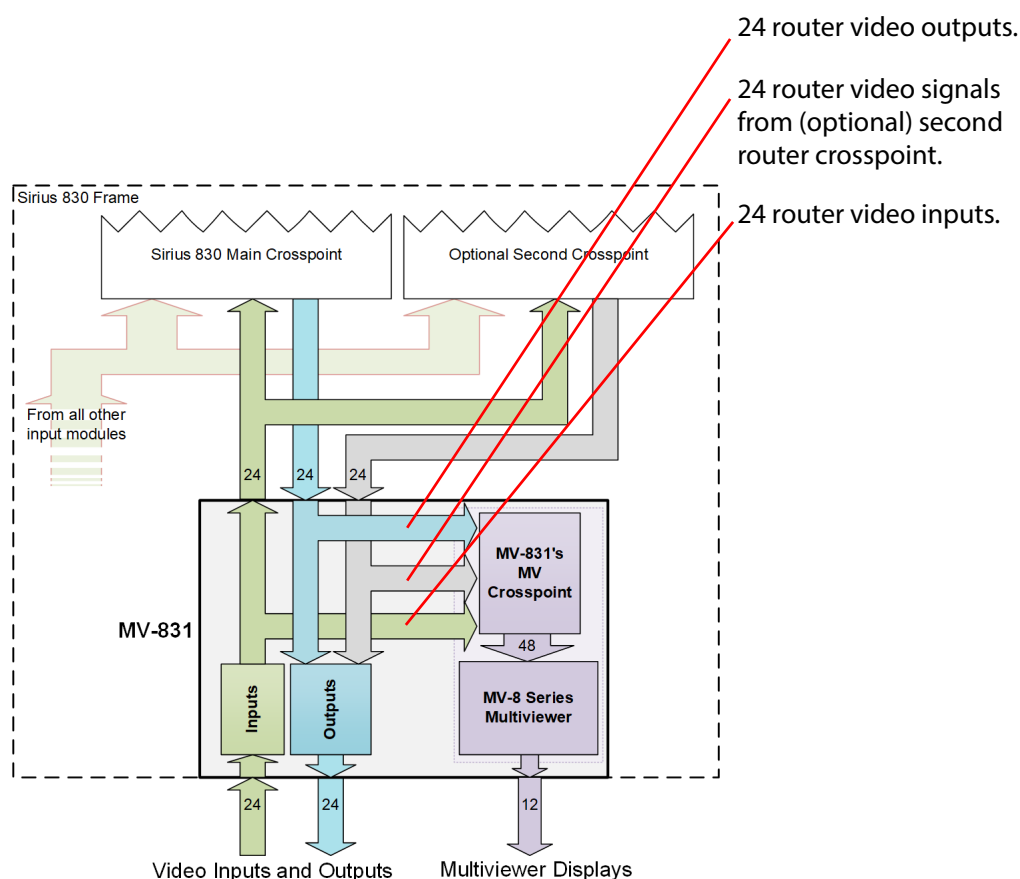

Fig. 1-5: Signals accessible by MV-831's Multiviewer Block

The multiviewer block can thus access up to $3 \times 24 = 72$ signals. However, it only has 48 multiviewer inputs. A small MV crosspoint selects the 48 signals for the multiviewer.

The simplest multiviewer monitoring mode is the default monitoring mode, see [MV-831 Default Monitoring Mode \(24 Outputs and 24 Inputs\)](#), on page 12.

Other signal monitoring combinations are under the control of the router configuration (see [Router Configuration Settings for Monitoring Mode](#), on page 13). [MV-831 General Monitoring Mode](#), on page 15, describes the general monitoring mode.

MV-831 Default Monitoring Mode (24 Outputs and 24 Inputs)

In a Sirius 830 with only a single video crosspoint card, there is one MV-831 multiviewer monitoring mode. This mode is also the default mode used in a Sirius 830 with two video crosspoint cards fitted; this default mode is used before any router configuration setting changes are made for the MV-831.

In this monitoring mode, MV-831 module's router outputs are mapped to the first 24 multiviewer inputs; the module's router inputs are mapped to the next 24 multiviewer inputs. See Figure 1-6 and Table 1-4.

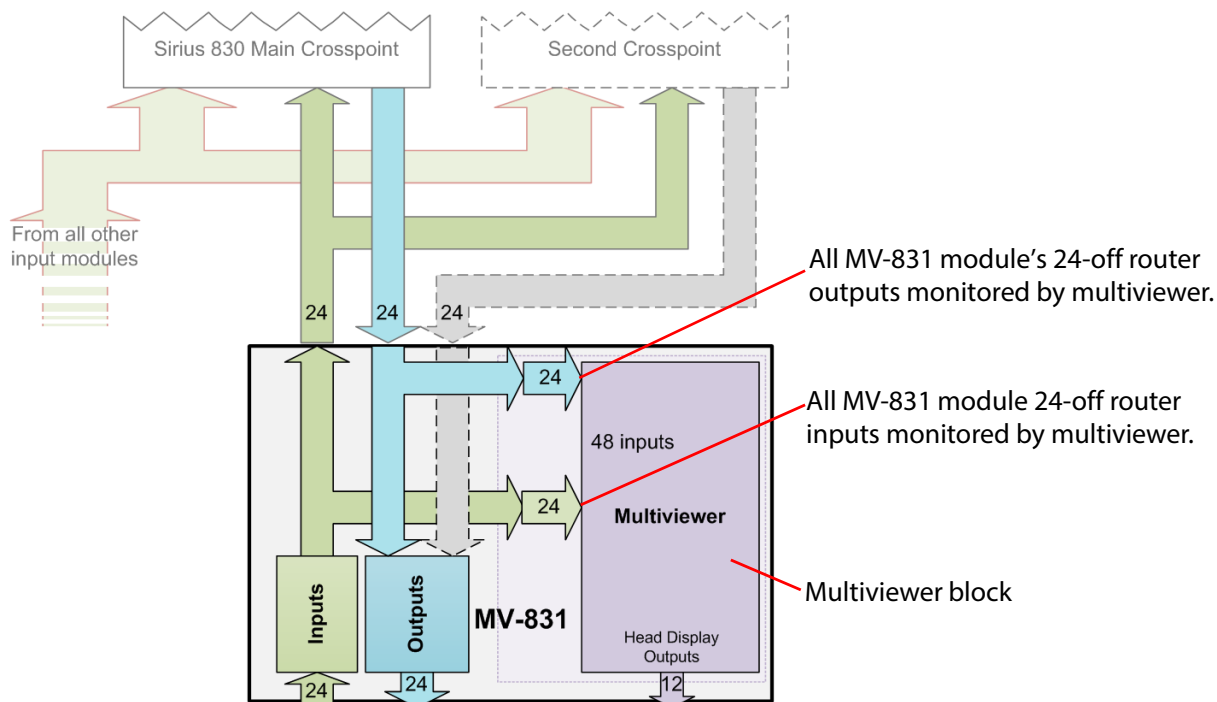

Fig. 1-6: MV-831 Default Monitoring Mode

Table 1-4: Multiviewer Inputs for Default Monitoring Mode

Multiviewer Block Input	Mapped to MV-831 Signals
1 to 24	Module Router Outputs 1 to 24
25 to 48	Module Router Inputs 1 to 24

Figure 1-7 shows an example video wall layout for the default monitoring mode: 24 router outputs at multiviewer inputs 1 to 24, and 24 router inputs at multiviewer inputs 25 to 48. The outputs have full routing redundancy if there is a second crosspoint is fitted to the host router.

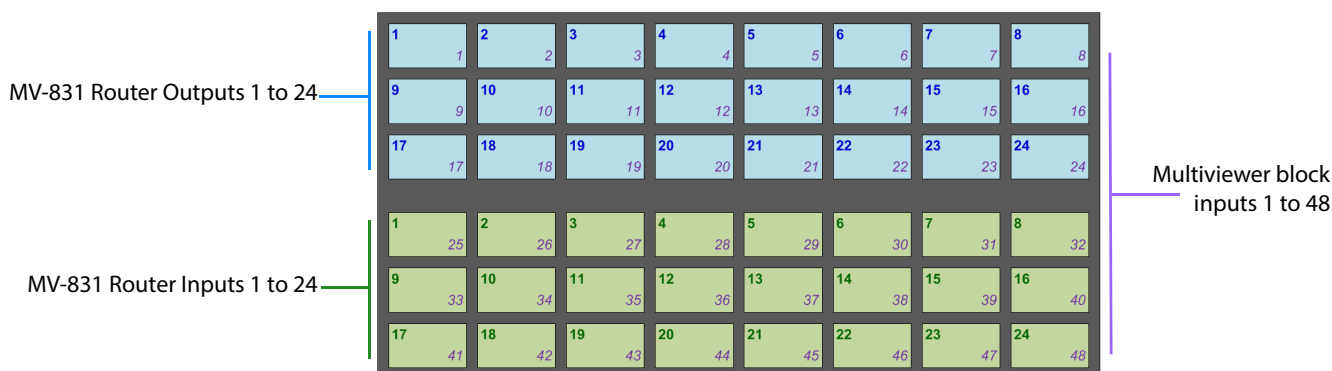

Fig. 1-7: Example 'Bingo Card' - Video Wall showing Default Monitoring Mode

Router Configuration Settings for Monitoring Mode

The default monitoring mode shows the router outputs and inputs of the MV-831. The multiviewer can also monitor any router source and it does this by using routing resources of the second crosspoint. However, this removes routing redundancy from one router output per router source monitored.

In a Sirius 830 router configuration when a second video crosspoint is fitted, two types of configuration setting determine what is monitored by the multiviewer of a MV-831 module:

- Redundant Crosspoint Enable.
- Main Output Follow.

Each MV-831 module presents 24 router outputs at its rear connectors. Each output has an associated redundant route in a second video crosspoint. And for each output, there is a 'Redundant Crosspoint Enable' and a 'Main Output Follow' setting.

Note:

By default, all the 'Redundant Crosspoint Enable' and 'Main Output Follow' settings are 'enabled', which results in the default monitoring mode.

These configuration controls may be set (i.e. enabled or disabled) with Grass Valley WorkBench software or via the Sirius 830's door PC. Example screenshots are given in Figure 1-8 and Figure 1-9 respectively.

Changing the 'Redundant Crosspoint Enable' and 'Main Output Follow' settings on an output-by-output basis affects what is monitored by the multiviewer. See [MV-831 General Monitoring Mode](#), on page 15.

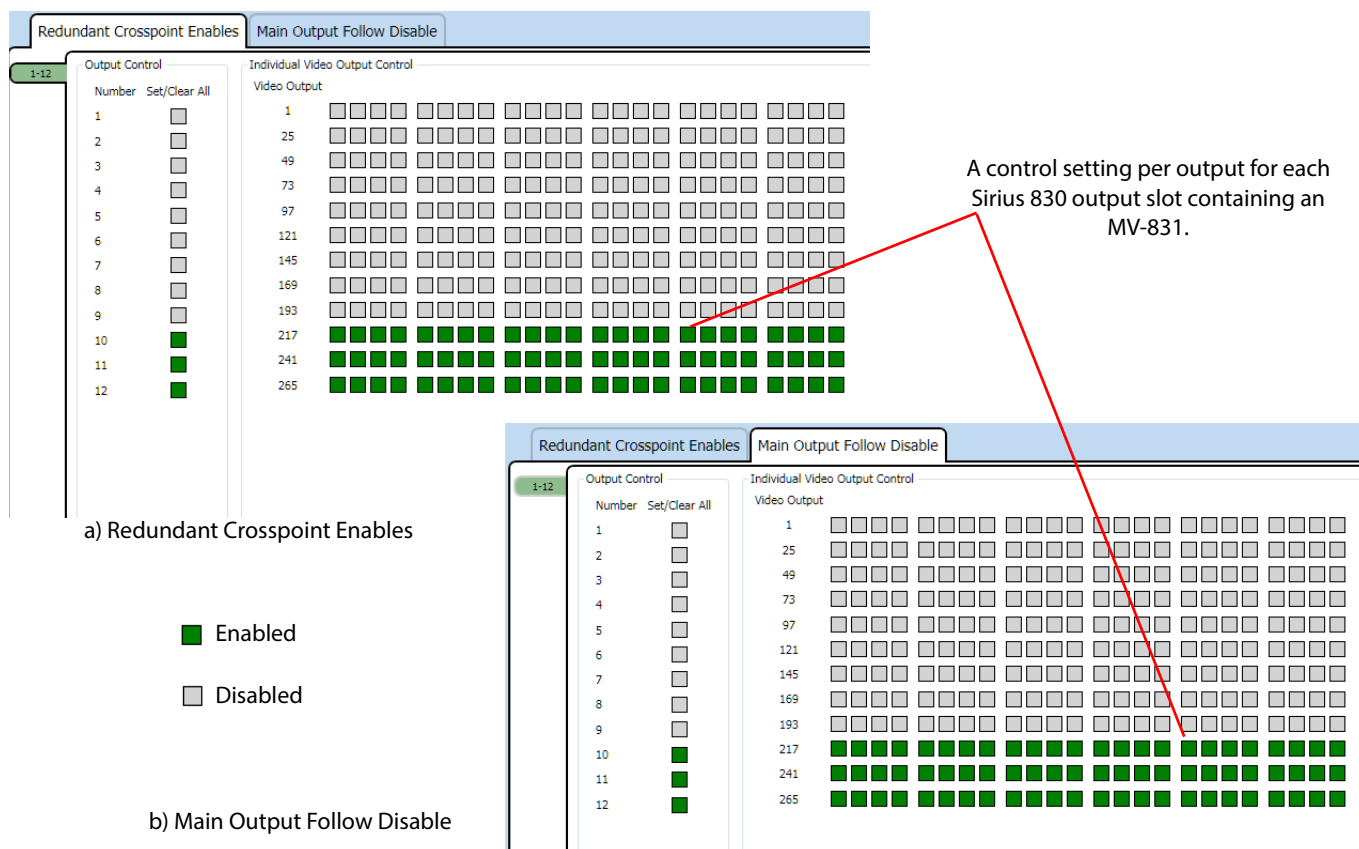
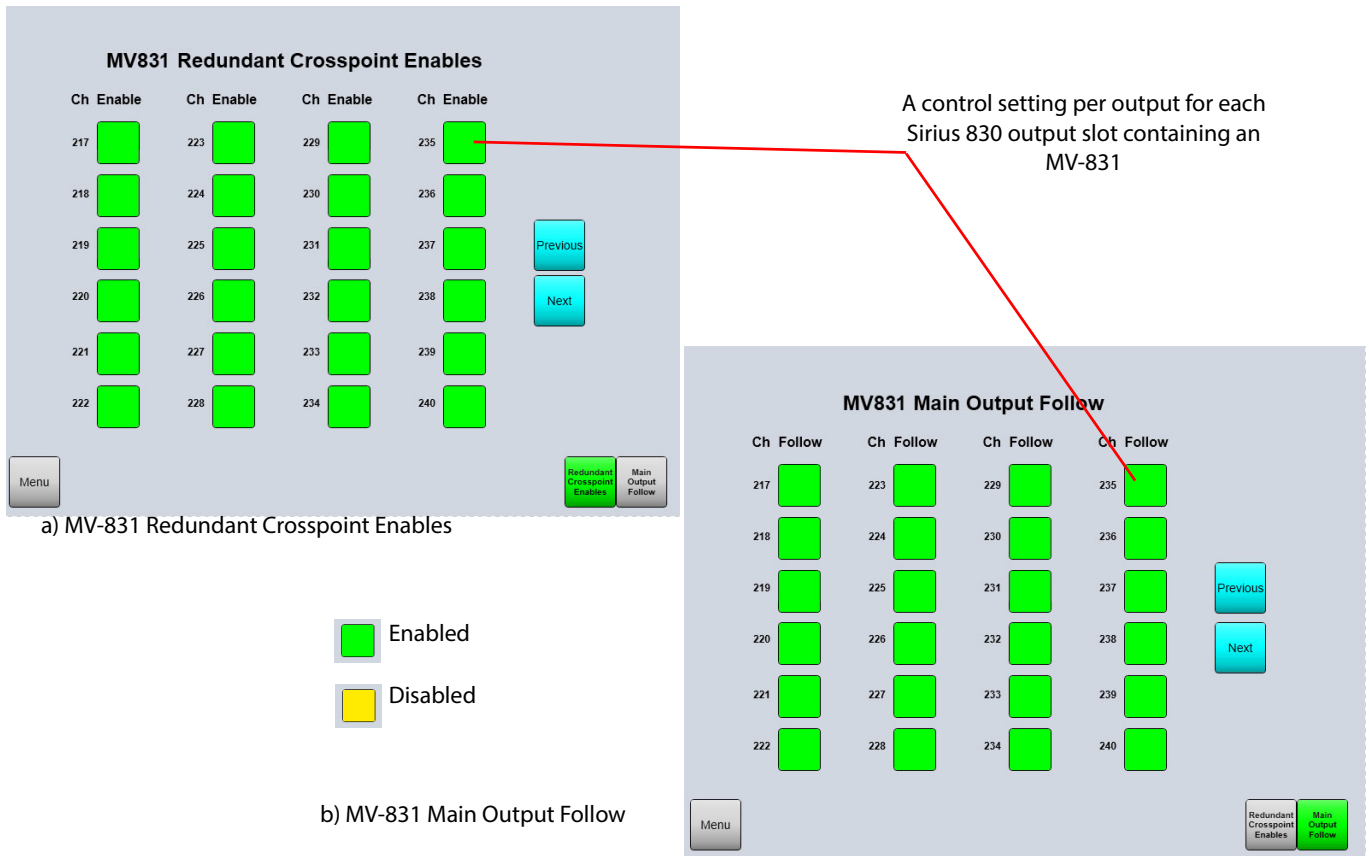

Fig. 1-8: Example Grass Valley WorkBench Software Tabs:
a) 'Redundant Crosspoint Enables'.
b) 'Main Output Follow Disable'.



A control setting per output for each Sirius 830 output slot containing an MV-831

Fig. 1-9: Example Sirius 830 Door PC Screens:
 a) 'MV-831 Redundant Crosspoint Enables.'
 B) 'MV-831 Main Output Follow'.

MV-831 General Monitoring Mode

Various monitoring combinations are possible by changing some router configuration settings, as described in Table 1-5.

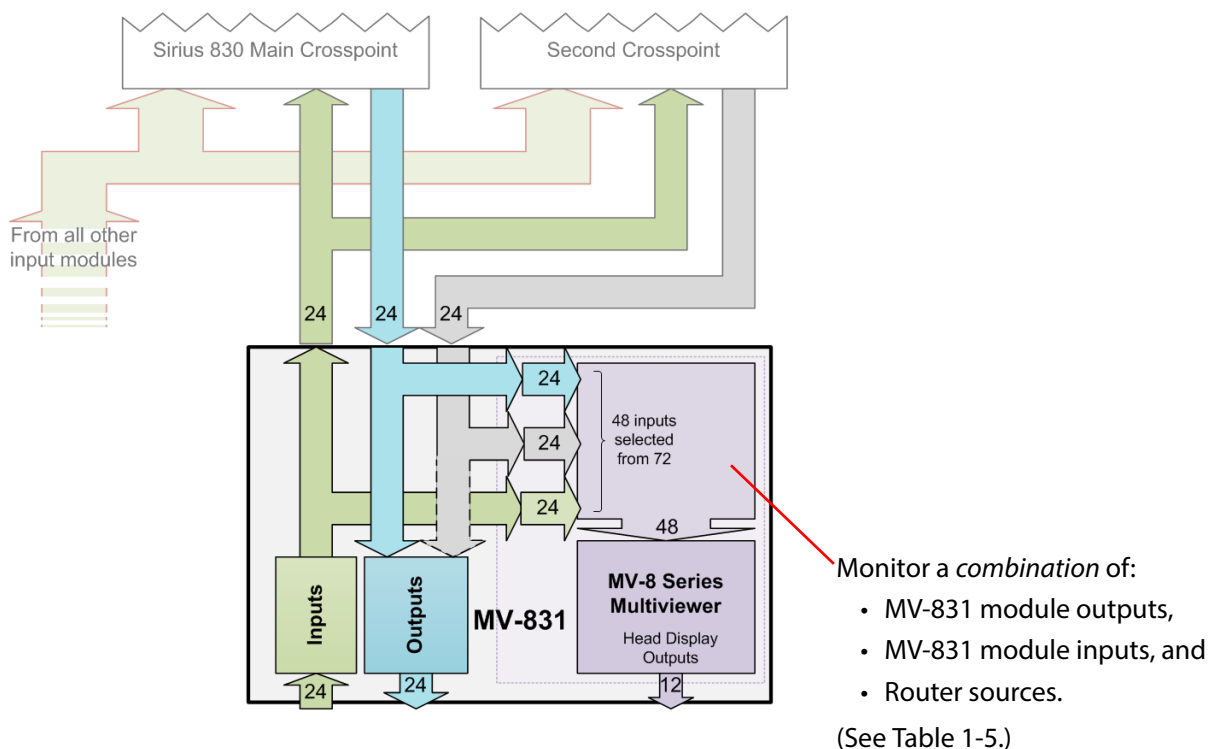

Fig. 1-10: MV-831 General Monitoring Mode

Table 1-5: MV-831 General Monitoring Mode Settings







Router Configuration Setting		Signals at MV-831 Module		
Redundant Crosspoint Enable	Main Output Follow	Multiviewer Block Input Signals		MV-831 Router Output Signals
		1 to 24	25 to 48	24-off
Enabled	Enabled	MV-831 Output (Redundant)	MV-831 Input	Same as MV block inputs 1 to 24 from Main/Redundant Crosspoint
Disabled	Enabled	MV-831 Output (NOT Redundant)	Router Source (re-purposes a destination of the second crosspoint, see Note 1)	Same as MV block inputs 1 to 24 but from Main-only Crosspoint
Disabled	Disabled	MV-831 Input		From Main-only Crosspoint
Enabled	Disabled			MV-831 Output (Redundant)

Note 1: When the second video crosspoint is re-purposed, make routes with the crosspoint by using higher destination port numbers. See Appendix B [Router Slot Information](#), on page 65, Table B-1.

General Mode Examples

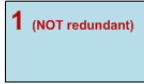
Examples are given in this sub-section to show how the general mode works on a video wall screen by altering the router configuration setting (see [Router Configuration Settings for Monitoring Mode](#), on page 13) for the first *four* outputs of a MV-831. See Table 1-6 and Figure 1-11.

Table 1-6: General Monitoring Mode Settings
 (as Table 1-5 but annotated for Figure 1-11)

Redundant Crosspoint Enable	Main Output Follow	Signal at Multiviewer Block Input	
		1 to 24	25 to 48
Enabled	Enabled	MV-831 Output (Redundant) 	MV-831 Input 
Disabled	Enabled	MV-831 Output (NOT Redundant) 	Router Source (re-purposes a destination of the second crosspoint) 
Disabled	Disabled	MV-831 Input 	MV-831 Output (Redundant) 
Enabled	Disabled		

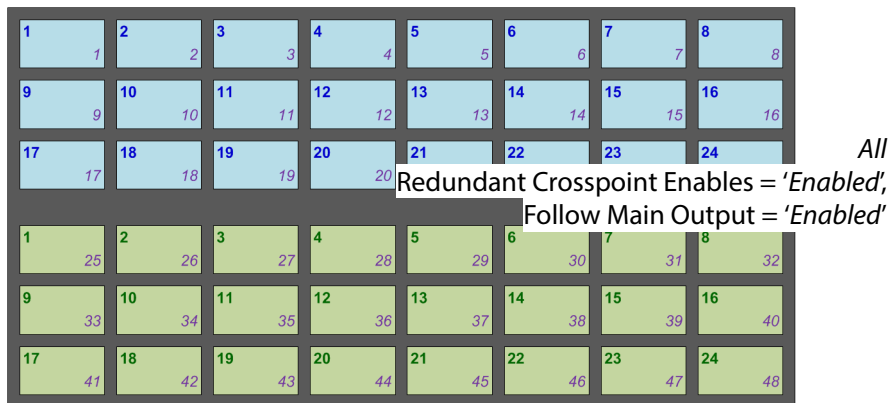

a) Monitor Outputs and Inputs (Default Monitoring Mode)

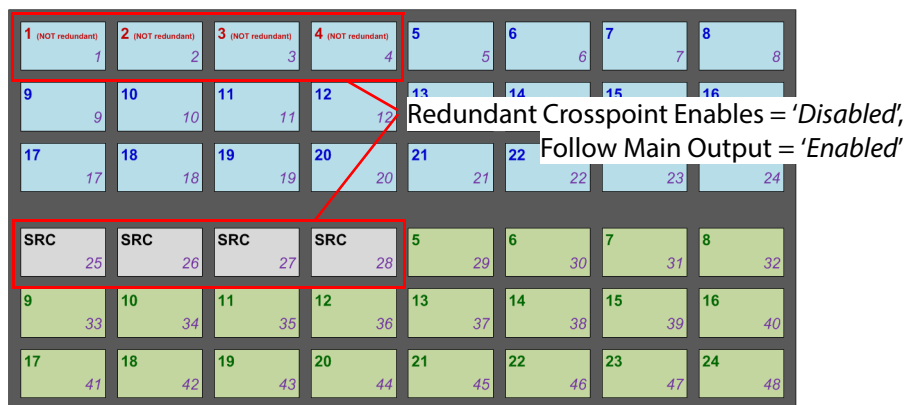

b) Monitor Outputs (non-redundant) and Sources

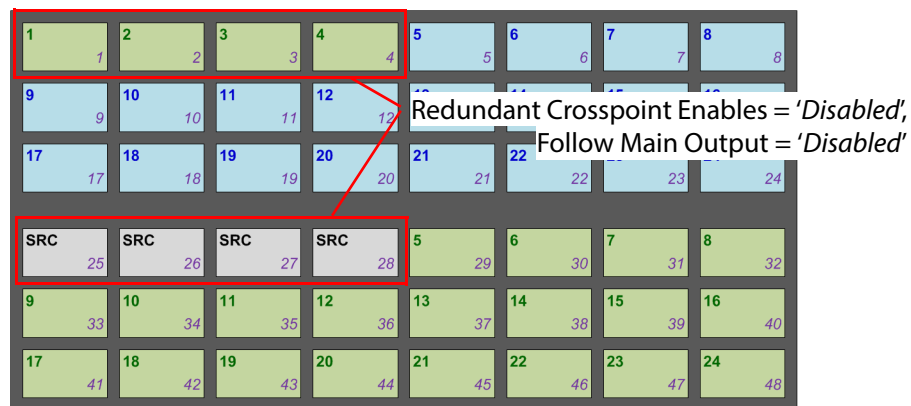

c) Monitor Inputs and Sources

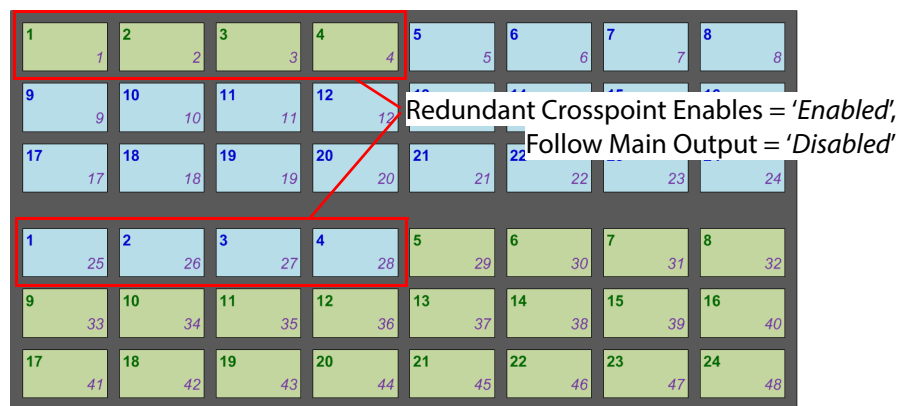

d) Monitor Inputs and Outputs

Fig. 1-11: Example Monitoring Modes (Shown for the first 4 outputs)

Software and Firmware Compatibility Matrix

Table 1-7 states the compatibility between MV-831 and various other software and firmware releases.

Table 1-7: MV-831 - Software/Firmware Compatibility Matrix

Software/Firmware Item	Software/Firmware version
MV-831 Multiviewer software	3.2.22 or later
MV-831 Multiviewer FPGA firmware	v16 or later
MV-831 Crosspoint FPGA firmware	PA1037 1.11 or later
RollCall Control Panel	v4.17 or later
Router Controller	v5.2.1 or later
Router Door PC	v5.2 or later
Grass Valley Workbench	v5.2 or later
Grass Valley GV Orbit Lite	1.0.0 or later
Sirius 830 Router Video crosspoint modules	Type 5905 with firmware PA1011 v3.00 or later

Multiviewer Terminology

Note: For a glossary of multiviewer terminology, refer to the 'MV-8 Series Multiviewer' user manual.

MV-831 Set up

Hardware Installation

Hardware installation is described in [Hardware Installation](#), on page 35.

Note: Upgrading of the Sirius 800 router controller software is described the 'Sirius Maintenance and Upgrade Manual', Section 9, "Nucleus Upgrade and Maintenance".

Router Power Supply Considerations

The available power supply capacity of a router depends on:

- Complement of modules fitted to the router.
- Power Supply Modules fitted to the router.

- Whether the MV-831 replaces any currently-fitted modules and their module type.

**Power supply considerations:**

The Sirius router must have enough power supply capacity to power any MV-831 Integrated Multiviewer modules being fitted.

There are many different Sirius 800 system module and power supply combinations. Therefore, before adding an MV-831 to a Sirius 830 router, check that the configuration of power supplies fitted to your router can supply sufficient power to the MV-831:

- See the Sirius 800 User Manual for router power requirements.
- See [Physical/Electrical](#), on page 57, for MV-831 power requirements.
- Contact Grass Valley support for advice.

Initial Multiviewer Configuration

Each MV-831 is configured separately: The MV-831 module's multiviewer functionality is a separate, independent sub-system within a host router.

Typically, a new MV-831 Multiviewer will be using a default IP address (10.54.31.221, 10.54.31.226 or 10.54.31.231) on Ethernet port 1 ("1G1"). See [Ethernet Rear Panel Connectors](#), on page 62, Table A-12 on page 62, for default IP addresses on all network ports.

Initial configuration and set up of the MV-831 multiviewer is done via Grass Valley's RollCall Control Panel application. See the 'MV-8 Series Multiviewer' user manual, in the section about RollCall templates and "Getting Started".

Configuration Screens (RollCall Templates)

Following the initial configuration of the MV-831 Multiviewer, the RollCall Control Panel tool may then be used to access RollCall templates and control various MV-831 items, including the selection of video wall layouts, monitoring alarm status, acknowledging alarms and control of timer widgets on the video wall.

Refer to the 'MV-8 Series Multiviewer' user manual for full details of the MV-831 module's RollCall templates and configuration information.

Video Wall Design

The layout and style of the MV-831 video walls are designed with the GV Orbit Lite software application. Wall designs are stored as individual projects (GV Orbit projects), which are pushed to an MV-831 for use.

Multiple wall layout designs may be generated and stored on a PC. Different wall designs can then be pushed to the multiviewer for various MV-831 multiviewer applications.

Note: For information about the design and management of MV-831 multiviewer video wall layouts with the GV Orbit Lite application, refer to the 'MV-8 Series Multiviewer' user manual.

Maintenance

Multiviewer Licensing

Note: For information about licensing the MV-831 multiviewer, refer to the 'MV-8 Series Multiviewer' user manual.

Multiviewer Software Upgrade

Note: For information about software upgrading the MV-831 multiviewer, refer to the 'MV-8 Series Multiviewer' user manual.

MV-831H.264 Streaming Out

An MV-831 has an MV-831-H264 license option, which enables streaming out of H.264-encoded copies of the input video signals going to the multiviewer block on the MV-831. Streaming is done over Ethernet interfaces 1 or 2. The option can be added later to MV-831 modules in the field.

2 MV-831 Hardware Modules

Summary:

MV-831 Hardware Modules

<i>Double-width Front Module (MV-831-MB)</i>	<i>page 22</i>
<i>Front LEDs, Connectors and Switches</i>	<i>page 23</i>
<i>Status LEDs</i>	<i>page 24</i>
<i>DIP switches</i>	<i>page 25</i>
<i>Engineering controls and connectors</i>	<i>page 25</i>
<i>Double-width Rear Panel (MV-830-RP)</i>	<i>page 26</i>
<i>Connectors</i>	<i>page 28</i>
<i>Rear Panel LEDs</i>	<i>page 29</i>
<i>LTC and GPIO Connector Pin-outs</i>	<i>page 32</i>
<i>Example: Driving LEDs from the GPI Outputs</i>	<i>page 34</i>

The MV-831 Multiviewer module performs the function of: 1-off router input module; 1-off router output module; and 1-off multiviewer. And an MV-831 module's hardware primarily comprises:

- Double-width Main front module (**MV-831-MB**).
See [Double-width Front Module \(MV-831-MB\)](#), on page 22.
- Double-width Rear panel module (**MV-830-RP**). Note: Same rear panel as MV-830.
See [Double-width Rear Panel \(MV-830-RP\)](#), on page 26.

MV-831-MB Front Module

MV-830-RB Rear Module

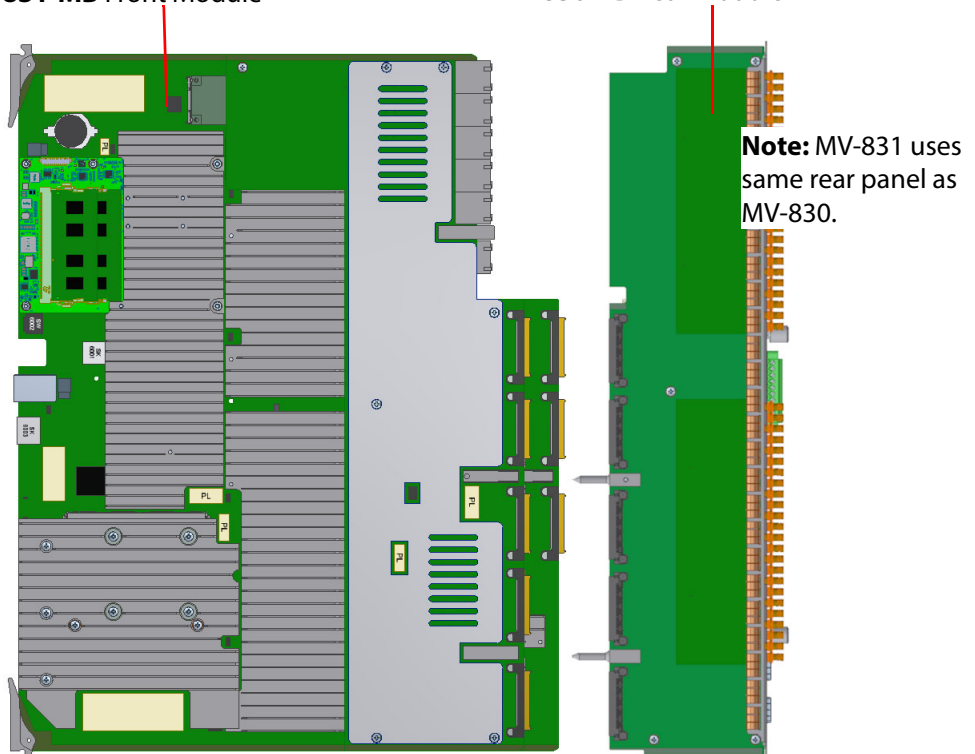

Fig. 2-1: MV-831 Multiviewer Double-width Front and Rear Modules

Double-width Front Module (MV-831-MB)



CAUTION **Electrostatic Damage:**

Static precautions must be observed when handling, inserting or removing modules.

The MV-831 Multiviewer front module is a double-width module, a full-sized Sirius router output front module occupying two slots (vertical, "input-output" slots) in a Sirius 830 router frame.

The front module assembly comprises a main card, a sub-card and a large gray metal heat plate. These items are not separately serviceable.

The rear panel assembly comprises a main card and two sub-cards. These items are not separately serviceable.

More than one MV-831 may be fitted to a Sirius 830 router, see [Table 1-1](#) on page 2.

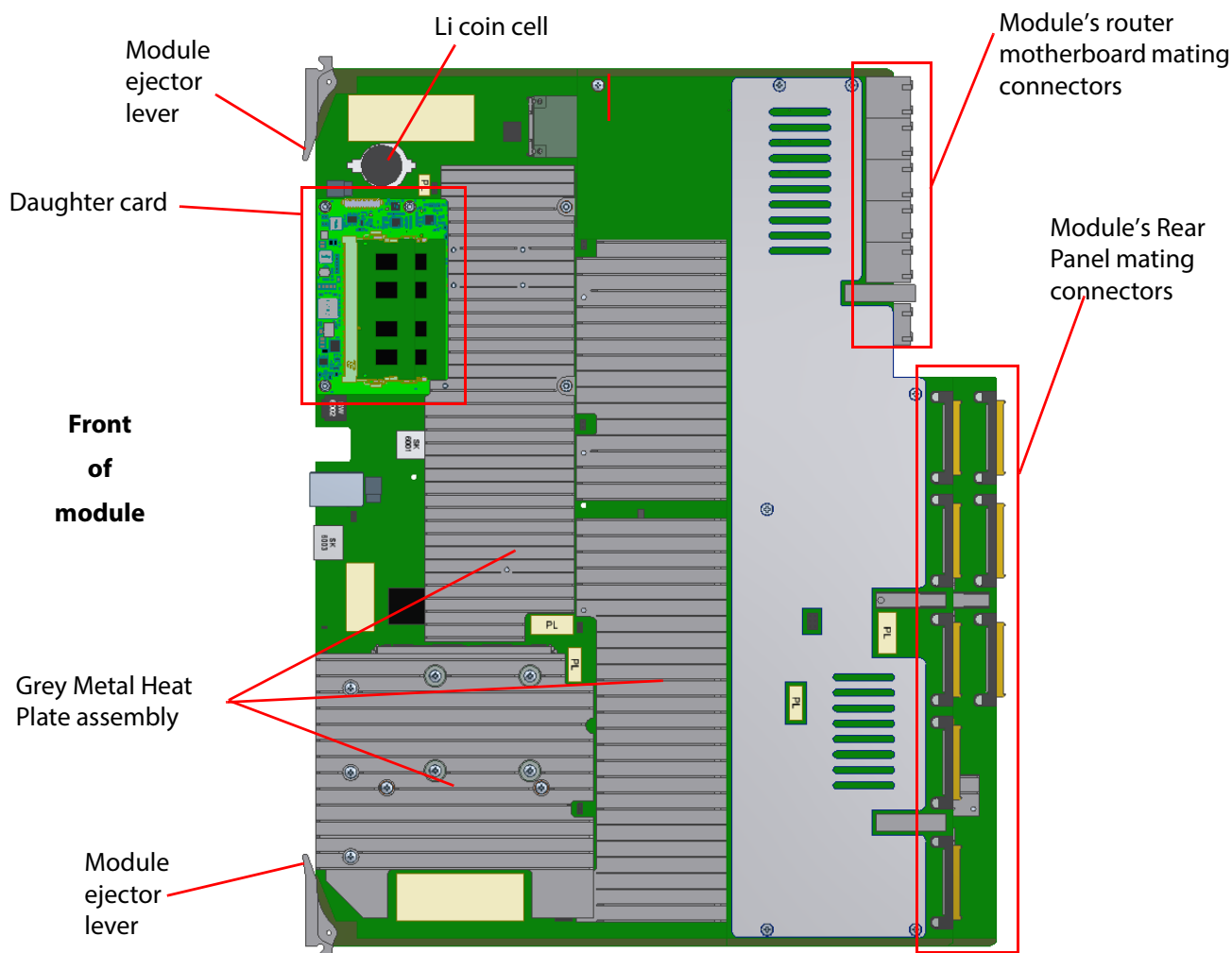

Fig. 2-2: MV-831 Multiviewer Front Module (MV-831-MB)

An MV-831 module replaces a Sirius 830 video input module and output video module: It replaces an "Input-Output" module pair. When viewed from the *front* of the Sirius 830 router frame, the left-most slot of the pair is the Input module.

See [Identifying Modules and Slots in the Sirius 830 Router](#), on page 40 for more information about locating the correct router module slots.

Front LEDs, Connectors and Switches

Figure 2-3 shows the front edge of the module and Table 2-1 shows the status LED color codes for the MV-831-MB module.

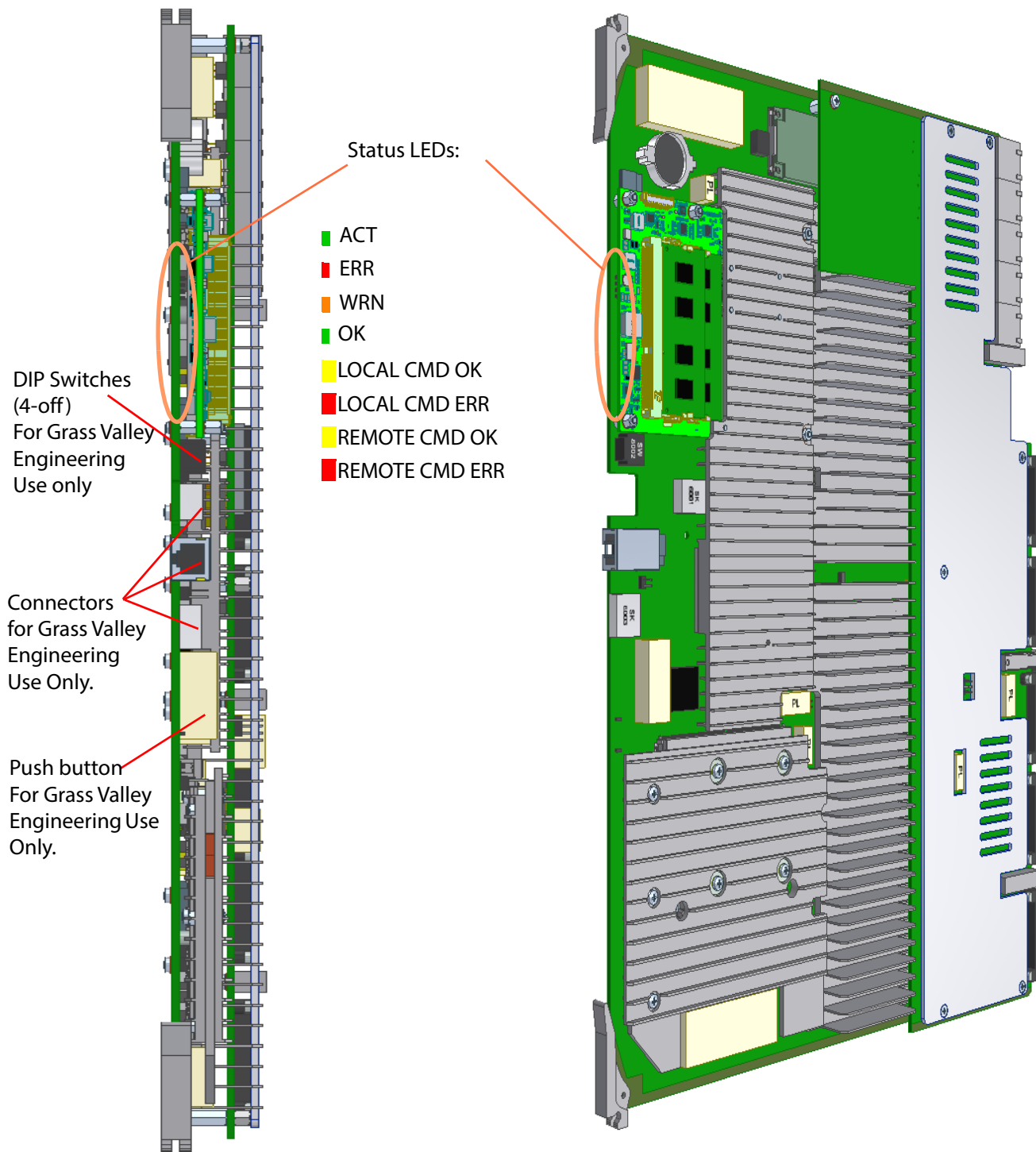

Fig. 2-3: MV-831-MB Front LEDs, Connectors and Switches

Status LEDs

Table 2-1: MV-831 Multiviewer Front Module LED Information





Label	LED Color	Detail	Status
ACT		Active Heartbeat	<p>Flashing (2Hz): Working correctly.</p> <p>Solid On or Off: Software fault detected. Contact Grass Valley Customer Support (see Grass Valley Technical Support, on page 67 for contact details).</p>
ERR		Error	<p>Off: Working correctly.</p> <p>On: Hardware fault detected. Contact Grass Valley Customer Support.</p>
WRN		Over Temperature Warning	<p>Off: Working correctly.</p> <p>On: MV-831 module overheating - ensure router fan doors are all closed and the fans are all operating correctly.</p>
OK		Hardware Communications	<p>Solid On: Working correctly.</p> <p>Flashing (2Hz): Hardware communications fault detected, contact Grass Valley Customer Support.</p>
LOCAL CMD OK		Local Command OK	<p>Receiving command messages from local router controller module. (I.e. a control module in the same router frame.)</p> <p>Flashing - receiving information and working correctly.</p> <p>Note: If both "LOCAL CMD ERR" LED is flashing and "LOCAL CMD OK" LED is also flashing, it suggests a mismatch in configuration of the router controller. Check the router controller configuration.</p>
LOCAL CMD ERR		Local Command Error	<p>Off - normal state.</p> <p>Flashing - Command message communication from the local router controller is corrupt or message has not been received.</p> <p>Note: If both "LOCAL CMD ERR" LED is flashing and "LOCAL CMD OK" LED is also flashing, it suggests a mismatch in configuration of the router controller. Check the router controller configuration.</p> <p>Note: A communications error could be caused by a hardware failure or incorrect module insertion. Check module is inserted correctly.</p>

Table 2-1: MV-831 Multiviewer Front Module LED Information (continued)

Label	LED Color	Detail	Status
REMOTE CMD OK	Yellow	Remote Command OK	<p>Receiving messages from a remote expansion router controller. (I.e. a control module in expanded router frame linked to this frame).</p> <p>Off - Router expansion not used. (relevant to Sirius 840 or 850 routers)</p> <p>Flashing - Receiving information and working correctly. (Only used for a Sirius 850 router system expanded to a second frame.)</p> <p>Note: If both the "REMOTE CMD ERR" LED is flashing and the "REMOTE CMD OK" LED is also flashing, it suggests a mismatch in the configuration of the router controller. Check the controller configuration</p>
REMOTE CMD ERR	Red	Remote Command Error	<p>Off - Expansion not used. (Used for Sirius 840 and Sirius 850 routers only.)</p> <p>Off - No router expansion to a second frame.</p> <p>Flashing - Command message communication from remote expansion router controller is corrupt or message has not been received.</p> <p>Note: If both the "REMOTE CMD ERR" LED is flashing and the "REMOTE CMD OK" LED is also flashing, it suggests a mismatch in the configuration of the router controller. Check the controller configuration.</p> <p>Note: A communications error could be caused by a hardware failure or incorrect module insertion. Check module is inserted correctly.</p> <p>Note: A communications error could be caused by a hardware failure or incorrect cable insertion. Check the four RJ45 connections between the two router frames are fitted correctly. (See Sirius 800 User Manual, section 12, Expansion.)</p>

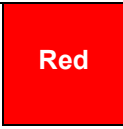
DIP switches

The four DIP switches are not used. Check that all four switches are in the "up" position.

Engineering controls and connectors

These control and connectors are for Grass Valley Engineering use only.

There is a push button on the front edge of the board. This is for engineering use only.

There are other connectors on the front edge of the module, see Figure 2-3. These are for Engineering use only and should not be used.

Double-width Rear Panel (MV-830-RP)



CAUTION Electrostatic Damage:

Static precautions must be observed when handling, inserting or removing modules.



WARNING

Handle and fit with care, the MV-830-RP Rear Panel has two sharp, pointed locating pins.

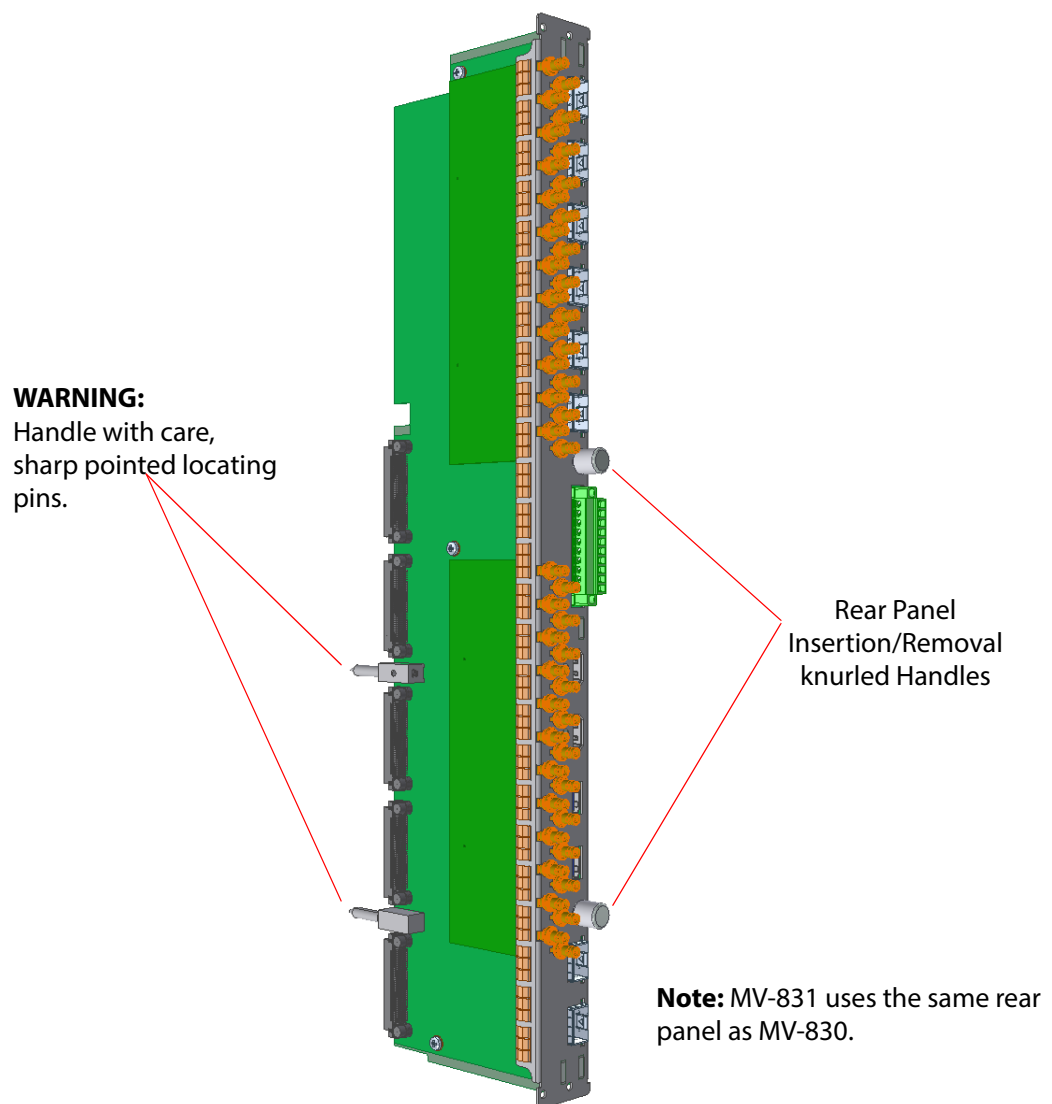

Fig. 2-4: MV-831 Multiviewer MV-830-RP

The MV-831 Multiviewer module has 24 router video input channels and 24 router output channels. It can handle SD, ASI and HD signals up to 3Gb/s.

The module can provide up to 12 multiviewer head display outputs, providing multiviewer video wall outputs.

Note: **ASI and MV-831:**

The Sirius 830 router can switch ASI signals and the router inputs and outputs of the MV-831 Multiviewer pass ASI signals. However, the multiviewer on the MV-831 only handles baseband video signals, i.e. SD/HD/3G signals and not ASI.

If an ASI signal is fed to the multiviewer on the MV-831, it will report signal loss.

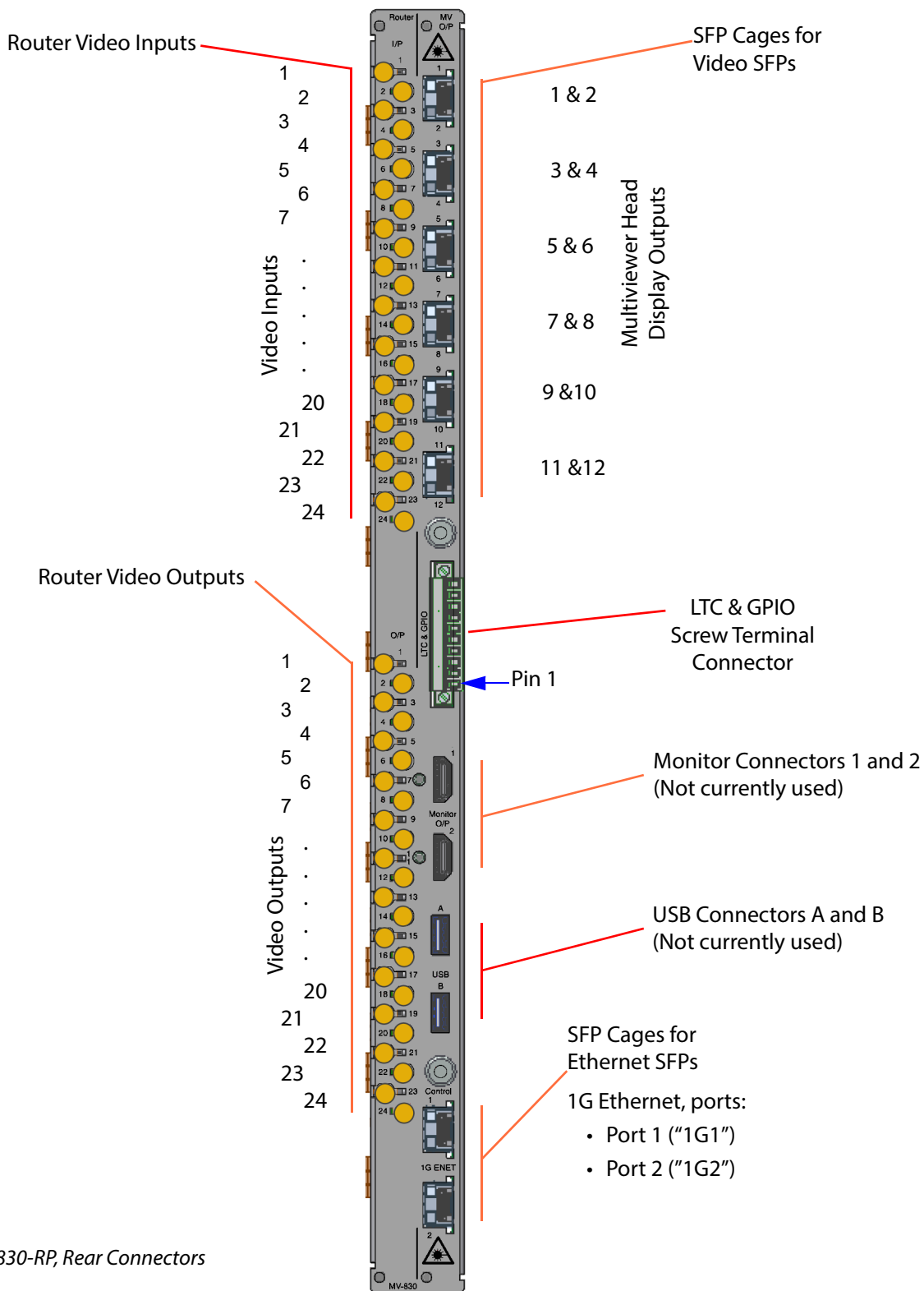

Fig. 2-5: MV-830-RP, Rear Connectors

The MV-831 rear connectors relate to either the module's router video input/output function or to the module's multiviewer function:

- 24 router video inputs and 24 router video outputs.
- Up to 12 multiviewer head display outputs from the MV-831:
 - 2 outputs per "SDI coax" or "fiber video" SFP module; or
 - 1 output per HDMI video SFP module.
- Ethernet ports for multiviewer video wall control.
- LTC and GPIO multiviewer connections.

The multiviewer head display outputs come from video SFP modules fitted into the SFP cages on the MV-831 Rear Panel. SFP blanking plugs must be fitted if an SFP is not fitted into any of the rear cages.

Connectors

Table 2-2 describes each connector type.

Table 2-2 MV-831 Multiviewer -RP Rear panel Connectors

Connector	Description
Router Input Function: Router Video Inputs	24-off HD-BNC.
Router Output Function: Router Video Outputs	24-off HD-BNC.
Multiviewer Function: Multiviewer Head Display Outputs 1 to 12	Multiviewer video wall outputs. 6-off SFP cages for SFP modules [See Note 1]: <ul style="list-style-type: none"> • 2-off SDI Coax outputs per SFP; or • 2-off SDI Fiber outputs per SFP; or • 1-off HDMI output per SFP.
Multiviewer Monitor Connectors 1 and 2	Not currently used
USB connectors A and B	Not currently used
LTC & GPIO Connector	Screw terminals. See Table 2-6 on page 33 for pinout details. Note: An LTC signal can also be sourced from the host router. This is selectable via the MV-831 module's RollCall templates. See 'MV-8 Series Multiviewer' user manual for the setting.
1G Ethernet Ports 1 and 2	2-off 1 Gbps, SFP+ Ethernet sockets, RJ45
Note 1: SFP blanking plugs must be fitted if no SFP is present.	

Rear Panel LEDs

Some rear connections include status LED indicators, see Figure 2-6.

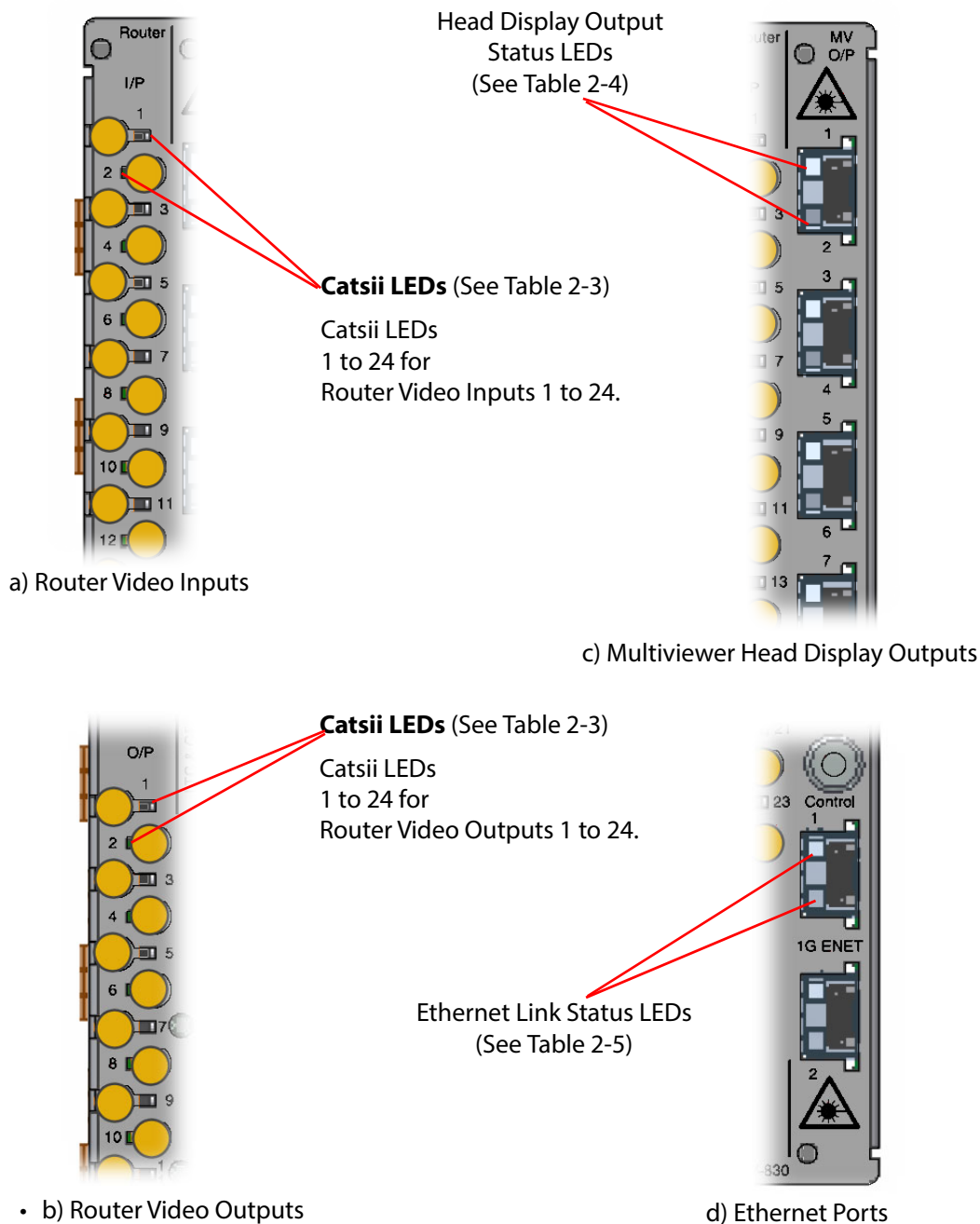

Fig. 2-6: Rear Panel LEDs:

- a) Router Video Inputs and Catsii LEDs.
- b) Router Video Outputs and Catsii LEDs.
- c) Multiviewer Head Display Outputs.
- d) Ethernet Ports.

Router Video Inputs and Outputs - Catsii LEDs









All the Router Video Input and Output HD BNC connectors on the rear panel have Grass Valley's unique Catsii LED feature that illuminate at each connector, one LED per connector.

The Catsii LEDs operate in one of two mutually-exclusive modes:

- 1 To indicate signal status.
- 2 To identify a specific HD BNC connector.

Refer to the Sirius 800 User Manual, Section 6 "Catsii Functionality", for full details of the Catsii feature.

Table 2-3 Router Video Input and Output Catsii LEDs







Catsii LED	Description
Signal Status Indication mode:	
	No valid signal
	Valid SD signal
	DVB-ASI Signal
	Valid 1080i or 1080p (30 Hz or lower) HD signal
	Valid 720p HD signal
	Valid 3G signal
Connector Identification mode:	
	Indicates row or column of connector to be identified.
	Connector to be identified.

Note 1: The positions of connectors on the rear of a MV-831 Multiviewer differ from those on a pair of normal Sirius 830 video input and output modules. In particular, the video input and output connector positions differ, which affects locating a particular connector in Connector Identification Mode. In 'Connector Identification' mode, the connector to be identified will be shown with a red LED.

Multiviewer Head Display Output LEDs

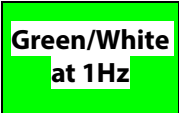
One status LED per output, 2 coax or fiber outputs per SFP. Table 2-4 describes LED functions.

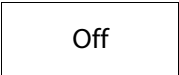
Table 2-4 Video Display Output Status LED

LED Color	Status
	Licensed Output; SFP Fitted. 1080p video output signal.
	Flashes Blue/White at 1 Hz. Licensed Output; SFP Fitted. 1080p video output signal with embedded audio.
	Licensed Output; SFP Fitted. 720p video output signal.
	Flashes Green/White at 1 Hz. Licensed Output; SFP Fitted. 720p video output signal with embedded audio.
	Licensed Output; No SFP Fitted.
	Unlicensed output.
	Flashes Red/Green at 1Hz during an internal FPGA upgrade, as part of a unit software upgrade.
	Flashes Red/Off at 1Hz after a unit software upgrade, if: <ul style="list-style-type: none"> • internal FPGA upgrading was unsuccessful; or • internal FPGAs fail to load during unit boot. <p>Note: A unit upgrade to the same version may be carried out to recover a unit if FPGA upgrading was unsuccessful. Otherwise, contact Grass Valley support.</p>

Ethernet Outputs

Two status LEDs per port. Table 2-5 describes the LED function.

Table 2-5 Ethernet Port LEDs

LED Color	Status
<div style="background-color: green; color: black; padding: 2px; display: inline-block; margin-bottom: 5px;">Green</div> <div style="border: 1px solid black; padding: 2px; display: inline-block; margin-bottom: 5px;">Off</div>	Ethernet link established.
<div style="background-color: green; color: black; padding: 2px; display: inline-block; margin-bottom: 5px;">Green</div> <div style="background-color: green; color: black; padding: 2px; display: inline-block; margin-bottom: 5px;">Flashing Green</div>	Activity on Ethernet link
<div style="border: 1px solid black; padding: 2px; display: inline-block; margin-bottom: 5px;">Off</div> <div style="border: 1px solid black; padding: 2px; display: inline-block;">Off</div>	Establishing link, or unconnected.

LTC and GPIO Connector Pin-outs

The MV-831 module has the facility for LTC and GPIO signals at its rear panel.

Note: LTC is also available from the host router and is selected via the MV-831 module's RollCall templates.
 (See the 'MV-8 Series Multiviewer' user manual.)

Female high density 26 way 'D' type connector assignments

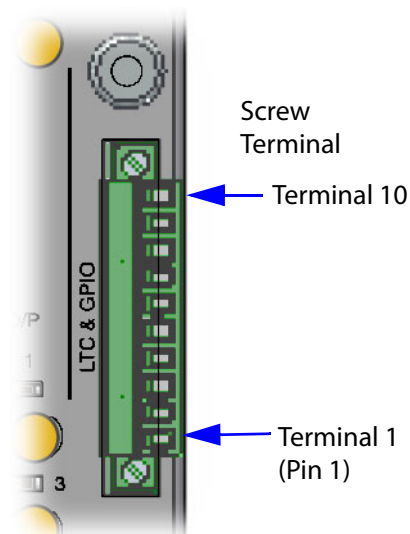

Fig. 2-7: LTC and GPIO Connector, 10-way Screw Terminal

Table 2-6 gives the pin assignments for the LTC and GPIO connector:

Table 2-6 Screw Terminal Connector for LTC and GPIO

Screw Terminal Number	Signal
1	GPI 1
2	GPI 2
3	GPI 3
4	GPI 4
5	+5 VDC Out
6	GND
7	LTC+
8	LTC-
9	nc
10	nc

Note: 'nc' denotes a "not connected" terminal.

Note: **MV-831 GPI outputs:**

Open collector outputs. Require external pull-up resistors of value between 10 k Ω and 100 k Ω . Each output can sink up to 100 mA.

- "+5 VDC Out" pins are provided on the connector for this purpose.
- Maximum voltage, +5 V.
- See [Example: Driving LEDs from the GPI Outputs](#) for an example of how GPI outputs can be used to drive LEDs.

Note: **MV-831 GPI inputs:**

Inputs have weak internal pull-down resistors.

- Can be driven by input voltages of up to +5 V.
 - A logic "low" input is represented by an input voltage below +0.8 V.
-

Example: Driving LEDs from the GPI Outputs

MV-831 GPI outputs have open collector drivers. There is a +5 V DC screw terminal on the GPIO connector to provide the power needed to drive LEDs or relays.

The following schematic is an example of the circuit needed to drive an LED by each GPI output. MV-831 GPIO connector pin names and numbers are shown on the left.

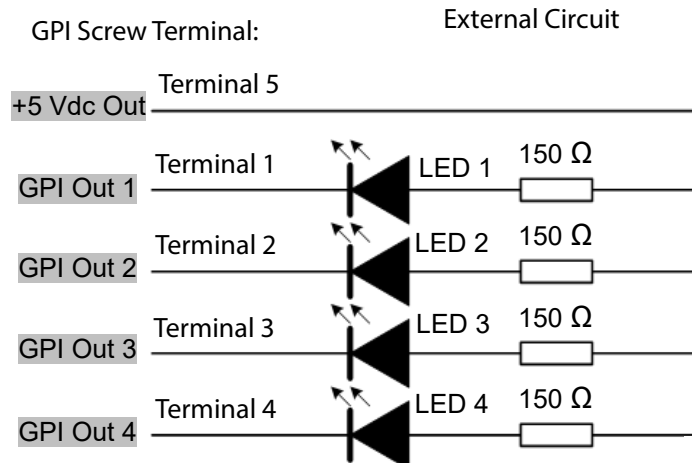

Fig. 2-8: Connecting LEDs to GPI Outputs



CAUTION Electrostatic Damage:

Static precautions must be observed when inserting and removing cards.

3 Hardware Installation

This section describes the unpacking and installation of the MV-831 Multiviewer hardware. Hardware installation can be carried out while the Sirius 830 router is operating, without impacting the main routing function.

Summary:

Hardware Installation

<i>Unpacking</i>	page 36
<i>Initial Checks and Actions</i>	page 37
<i>Router Model Check</i>	page 37
<i>Router Frame Check</i>	page 37
<i>Power Checks</i>	page 37
<i>Router Module Type and Input/Output Port Type</i>	page 38
<i>Fitting of Video SFPs to MV-831 Rear Panel</i>	page 38
<i>Identifying Modules and Slots in the Sirius 830 Router</i>	page 40
<i>Removal and then Fitting of Modules</i>	page 45
<i>Removal Preliminaries</i>	page 45
<i>Module Removal Procedure</i>	page 46
<i>Fitting Preliminaries</i>	page 48
<i>Module Fitting Procedure</i>	page 49
<i>Connecting Cables</i>	page 53
<i>MV-831 Module Booting</i>	page 55

If your Sirius 830 router has been purchased from Grass Valley with one or more MV-831 Multiviewer options already fitted, then the MV-831 hardware installation task just comprises making connections to the MV-831 Rear Panel at the rear of the router. (See [Connecting Cables](#), on page 53.)

If the MV-831 is being fitted to an existing, installed router, then the MV-831 hardware is shipped separately and requires unpacking and installing, which is described in this section.

More than one MV-831 unit may be fitted to a Sirius 830 router and these instructions cover the fitting of one or more units.

Unpacking

The MV-831 Multiviewer is supplied in dedicated packaging provided by the manufacturer and should not be accepted if delivered in inferior or unauthorized materials.



CAUTION **Electrostatic Damage**

Static precautions must be observed when handling, inserting or removing modules.

- 1 Carefully unpack the system components and check them against the listed items here:
 - MV-831 Multiviewer main module.
 - MV-831 Multiviewer rear module.
- 2 Check that the equipment has not been damaged in transit. If there is anything incorrect, then notify your Grass Valley Partner, or Grass Valley, at once.
- 3 Always retain the original packing materials if possible, they could prove useful should it ever be necessary to transport or ship the equipment.
- 4 Always read the installation guide and the user instructions carefully, it will provide you with helpful hints and tips about care and maintenance and help you get the most out of your MV-831 Multiviewer.
(Grass Valley manuals may be downloaded from <http://www.grassvalley.com/products/>)

Initial Checks and Actions

Router Model Check

The MV-831 Multiviewer modules must only be fitted into a Sirius 830 router. The MV-831 does **not** fit into Sirius 840 nor Sirius 850 routers.

IMPORTANT

Fit MV-831 Multiviewer modules into a **Sirius 830 router only**.

MV-831 Multiviewer modules must NOT be fitted into a Sirius 840 nor a Sirius 850 router.

Router Frame Check

The MV-831 Multiviewer modules must only be fitted into a Mark 3 Sirius router frame. This router frame has a blue fan rack (see Sirius User Manual, section 3.12.1, Table 5).

IMPORTANT

Fit MV-831 Multiviewer modules into a Sirius 830 **Mark 3** router frame.

The Sirius 830 router controller software version installed on the router must support the MV-831 Multiviewer. If an upgrade of the Sirius 830 router controller software is required, it can be carried out either before or after the MV-831 hardware installation.

Note: Software version information is found in [Software Versions](#), on page 62.

Power Checks

Your Sirius 830 router may already have enough power supply capacity to power the additional MV-831 module(s).

However, there are many different Sirius 830 system module combinations. Therefore, before adding any MV-831s to a Sirius 830 router, check that the configuration of power supplies and modules fitted to your router can supply sufficient power to the MV-831 Multiviewer(s):

A router's available power supply capacity depends on:

- Complement of modules fitted to the router.
- Power Supply Modules fitted to the router.
- Whether the MV-831 replaces any currently-fitted modules and their module type.

**CAUTION Power supply considerations:**

The Sirius router must have enough power supply capacity to power any MV-831 Integrated Multiviewer modules being fitted.

Check that the configuration of power supplies fitted to your router can supply sufficient power to the MV-831 Multiviewer:

- See Sirius 800 User Manual for router power requirements.
- See [Physical/Electrical](#), on page 57, for MV-831 power requirements.
- Contact Grass Valley support for advice.

Router Module Type and Input/Output Port Type

The MV-831 is a double-width module, occupying one input slot and one output slot in a Sirius 830 router frame. The router controller configuration of the hosting router must be modified for each MV-831 fitted:

[Router Controller Configuration Items](#), on page 63, lists the types etc to use in a router controller configuration.

Fitting of Video SFPs to MV-831 Rear Panel

Fitting of SFPs can be done before or after an MV-831 Rear Panel (MV-830-RP) is fitted into a router frame.

WARNING
Handle and fit the MV-830-RP Rear Panel with care;
it has some sharp, pointed locating pins.

This sub-section provides SFP video module fitting guidelines.



Fig. 3-1: Coax and fiber SFP video modules

WARNING: Handle with care, pointed locating pins.

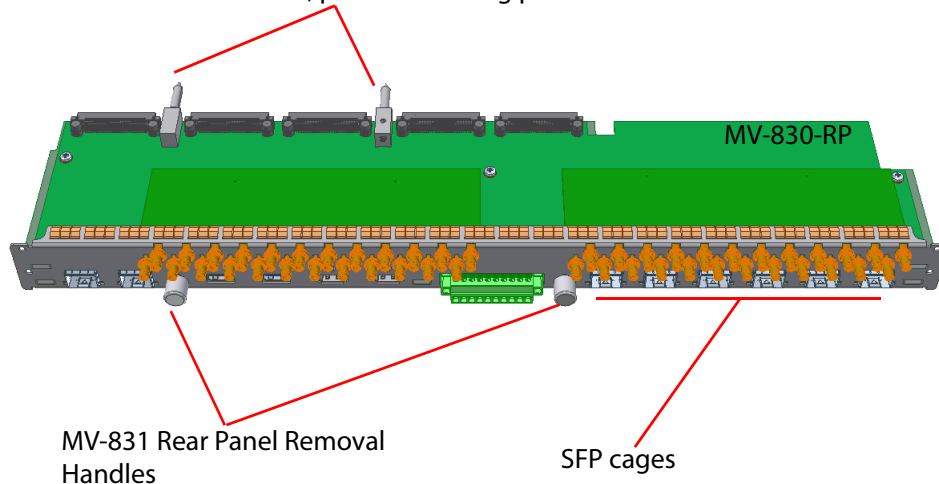

Note: The normal orientation of the MV-831 Rear Panel in the router is vertical.

Fig. 3-2: MV-831 Rear Panel (shown in a horizontal orientation)

Before inserting the SFP modules, take notice of the required SFP orientation for fitting into the SFP cages of the MV-831 Rear Panel, as shown in Figure 3-3.

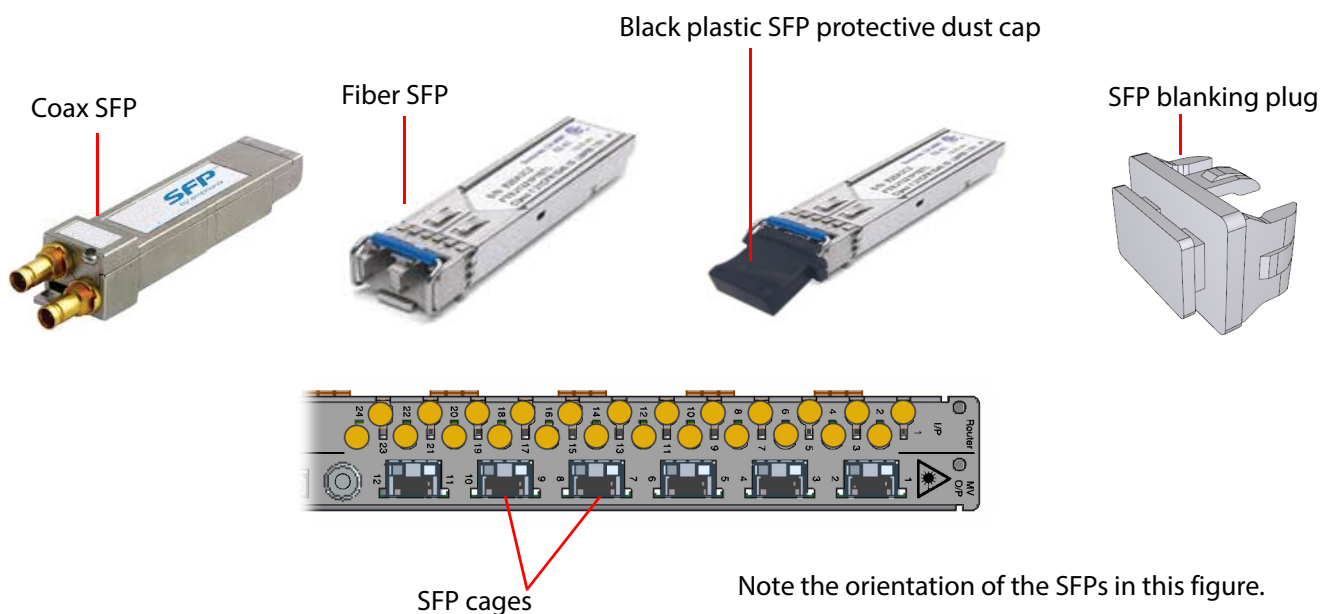

Fig. 3-3: SFP orientation for fitting into MV-831 Rear Panel SFP cages

Insert the SFP video modules into the SFP cages on the MV-831 Rear Panel. The modules slide in until there is an audible click.

Start by filling the SFP cage for output pair 1 & 2, then 3 & 4 etc. see Figure 3-4. Fill any remaining slots with SFP blanking plugs (SFP-BLANK).

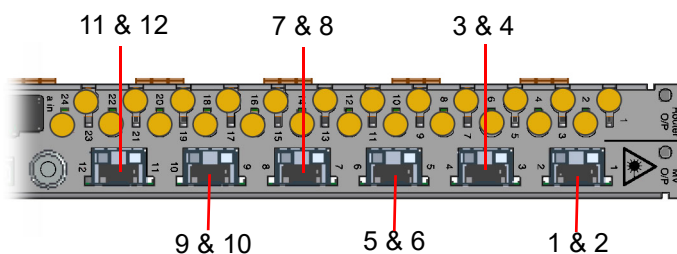

Fig. 3-4: MV-831 outputs 1 to 12

SFP module removal, if required, is achieved by operating a small lever or lever-bar on the SFP module before sliding the SFP video module out of its cage.

Identifying Modules and Slots in the Sirius 830 Router

This sub-section locates the slots in the router frame for the MV-831 Multiviewer. Slots must be located precisely in the router frame to ensure correct and swift MV-831 hardware installation, and to avoid the risk of disruption to the router and its operation.

To help locate the relevant slots for the MV-831 option, please also refer to the Sirius 800 User Manual ("Module Location" section).

Locating slots:

STEP 1: Locate the relevant section of the router frame. Table 3-1 states which section of the router frame (both front and rear) to look at. This is shown in Figure 3-5.

Table 3-1: Section of Router Frame for MV-831 installation

Router	Section of router frame	Comment
Sirius 830	Lower section, vertical slots.	See Figure 3-5.
Sirius 840	N/A	MV-831 is not compatible with Sirius 840.
Sirius 850	N/A	MV-831 is not compatible with Sirius 850.

Lower Fan Door

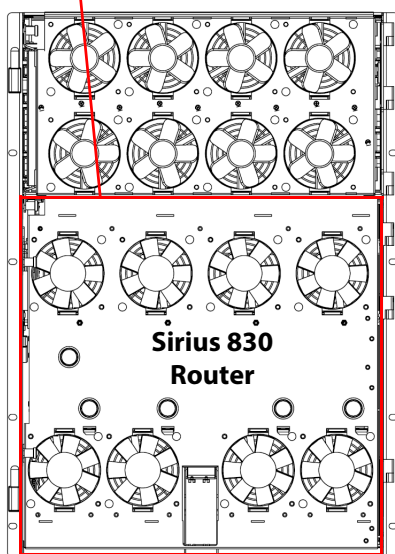

a) Front View of router frame
 (Outer front door open, fan doors shown).

Rear lower Input and Output Module slots

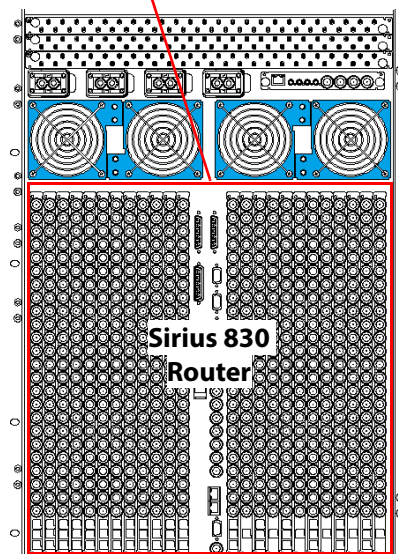

b) Rear View of router frame.

Fig. 3-5: Lower section of Sirius 830 router frame for MV-831 installation,
 a) Front view (Fan Doors).
 b) Rear Panel Section.

IMPORTANT

Module slots in Sirius 830 router frame:

- Lower-**front** vertical module slots:
 Front slots: alternately "**Input**", "**Output**"... from left to right.
- Lower-**rear** vertical module slots:
 Rear slots: alternately "**Output**", "**Input**"... from left to right.

STEP 2: Locate and identify the relevant module slots suitable for the MV-831 Multiviewer.

Figure 3-6 indicates input and output module slots for in the Sirius 830. This figure shows a skeletal drawing of router modules, internal cards and rear panels.

The MV-831 module is a double-width module, occupying a pair of front and corresponding rear slots.

The MV-831 module occupies certain pairs of adjacent input-output module slots (slot-pairs) in the router frame. When viewing the router from the front, the Input module must be the left-most slot of the chosen slot-pair.

IMPORTANT

Do not disturb any of the router's other modules, otherwise router operation may be affected.

IMPORTANT

Only open router outer and fan doors for less than 2 minutes and ensure they are fully closed afterwards. This ensures continued cooling of the router.

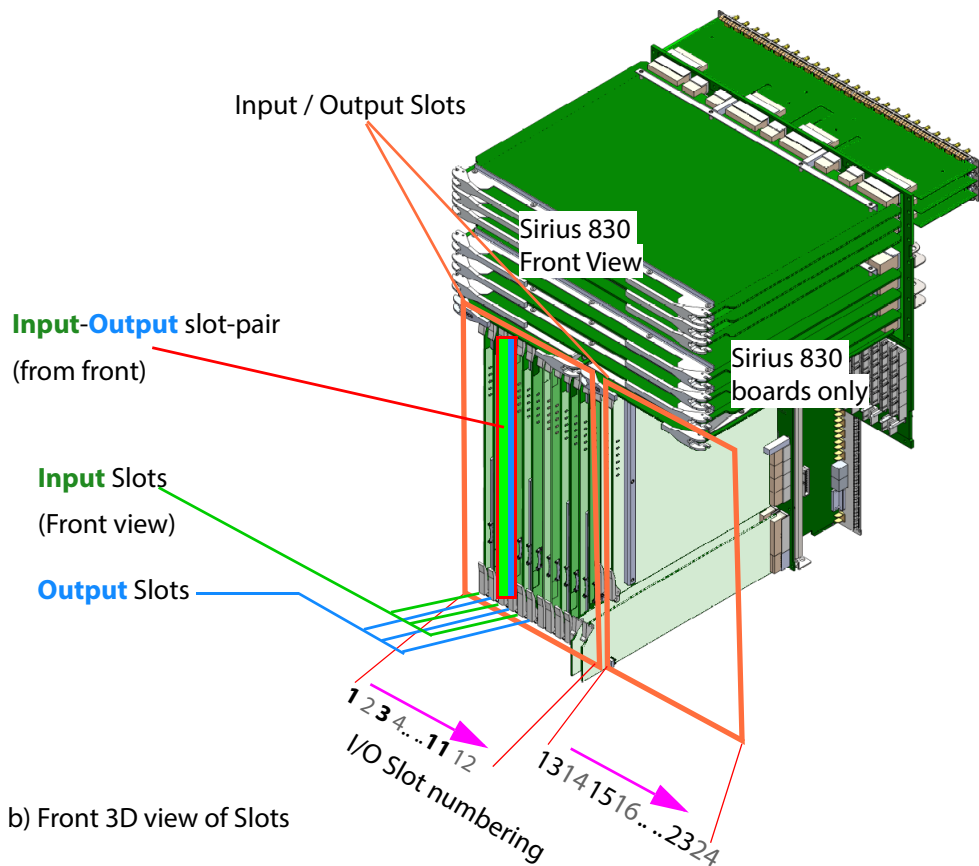
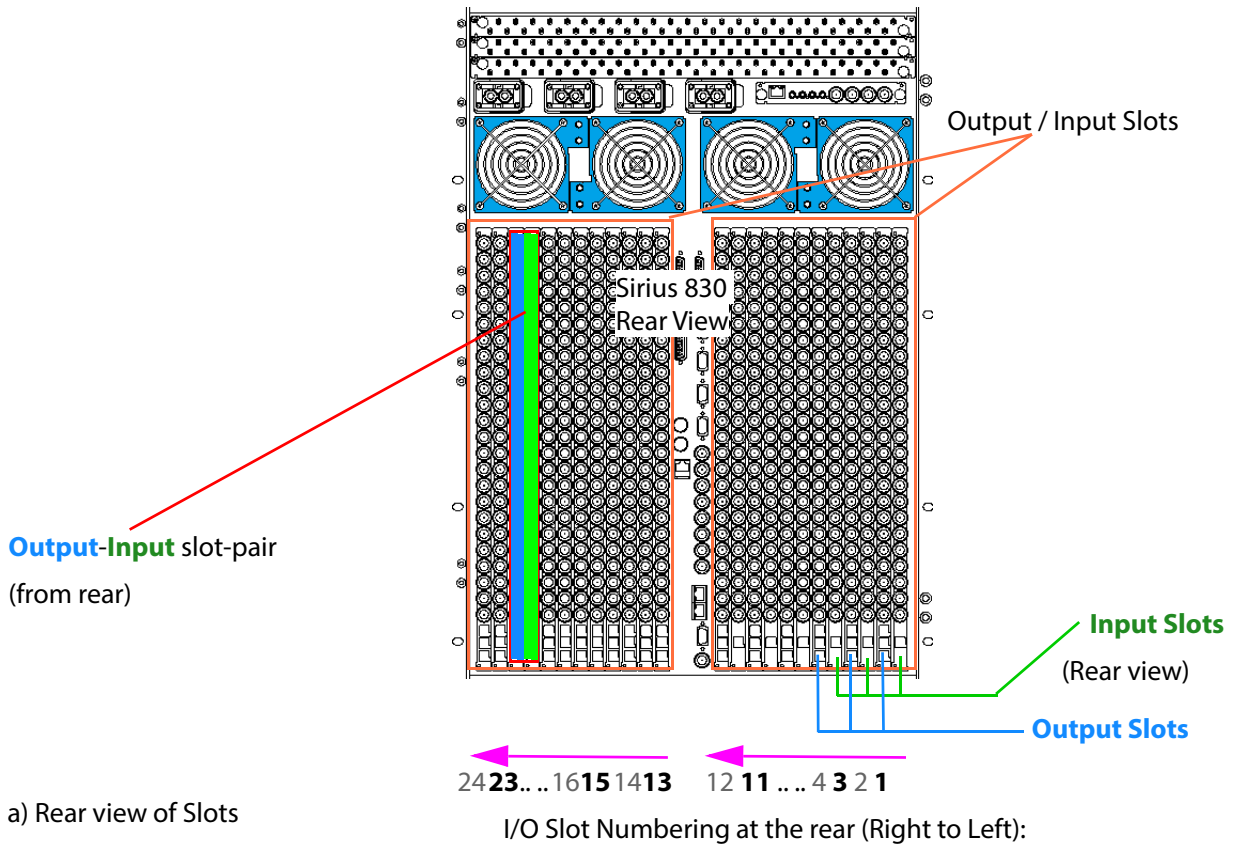

Fig. 3-6: Sirius 830 - Module Slots for MV-831 module(s)
 a) Rear view of Slots; and b) Front 3D View of Slots.

STEP 3: Use [Table 3-2](#) on page 44 to record the module names and slot locations of all the Sirius 830 router input/output modules *already fitted* to your router.

Record this in the "Current Modules" columns of Table 3-2.

Note: Table 3-2 records the locations of modules and may be used as a reference when at the front or at the rear of the Sirius 830 router frame.

STEP 4: In Table 3-2, note the slot-pairs (Front and Rear) to be used for the MV-831(s).

Note: An MV-831 may occupy any pair of "input-output" slots.

Slot-pairs for MV-831 are I/O slot numbers:

- 1 and 2;
 - 3 and 4;
 - 5 and 6; etc. up to
 - 23 and 24.
-

Note: When completed, [Table 3-2](#) on page 44 will indicate:

- Location and type of modules which may need to be removed before MV-831 installation.
- Location for insertion of MV-831 modules.

Table 3-2 can be used as a reference sheet for the front and rear of the Sirius 830 router frame.

Table 3-2: Sirius 830 Input/Output Slot Record Sheet

Sirius 830 Input/Output Slot Record Sheet

I/O Slot#	Front Modules		INPUT and OUTPUT NUMBER	Rear Modules		I/O Slot#
	Fitted Modules	MV-831 Slot Pair(s)		MV-831 Slot Pair(s)	Fitted Modules	
FRONT VIEW	1		1 input 1			1
	2		1 output 1			2
	3		2 input 2			3
	4		2 output 2			4
	5		3 input 3			5
	6		3 output 3			6
	7		4 input 4			7
	8		4 output 4			8
	9		5 input 5			9
	10		5 output 5			10
	11		6 input 6			11
	12		6 output 6			12
13			7 input 7			13
14			7 output 7			14
15			8 input 8			15
16			8 output 8			16
17			9 input 9			17
18			9 output 9			18
19			10 input 10			19
20			10 output 10			20
21			11 input 11			21
22			11 output 11			22
23			12 input 12			23
24			12 output 12			24
						REAR VIEW
	Fitted Modules	MV-831 Slot Pair(s)	INPUT and OUTPUT NUMBER	MV-831 Slot Pair(s)	Fitted Modules	
	Front Modules			Rear Modules		

Removal and then Fitting of Modules

This section covers:

- removal of any existing modules from relevant slots in the router frame;
- the fitting of a MV-831 module. Modules may be fitted while the router is powered up.

Removal Preliminaries

Some warnings and points of note are provided below: The following removal and fitting procedures are designed to comply with these points.

Prepare all required modules, rear panels and other components.

Note: A MV-831 comprises a double-width front module and rear panel.
Thus MV-831 occupies the following Sirius 830 router slots:

- A pair of front input-output module slots. (Slot numbers 1-2, 3-4, etc)
 - A pair of corresponding rear output slots.
-

Before fitting a MV-831 module, the relevant front and rear module slots need to be emptied first before fitting the MV-831 option hardware.



CAUTION

Ensure both of the front *and corresponding* rear slots in the router frame are *first empty* before inserting the MV-831 Main Module and/or MV-831 rear panel (MV-830-RP).

This is because:

- MV-831 front Main Modules must not be accidentally connected to any other rear panels already fitted in the router frame.
- MV-831 Rear Panels must not be accidentally connected to any other front modules already fitted in the front of the router frame.



WARNING

Handle and fit with care, the MV-830-RP Rear Panel has some sharp, pointed locating pins.

These instructions are deliberately written in two stages:

- 1 Removal. (See [Module Removal Procedure](#) on page 46.)
- 2 *Then* fitting. (See [Fitting Preliminaries](#) on page 48.)

This avoids any interim incompatibility between different front and rear modules during fitting, which may damage modules and the router.

Note: **Fan doors**

The fan door assemblies should be returned to the closed position as soon as possible after opening. This ensures correct ventilation and operation of the router frame.

In practice:

- Maximum time that a fan door may be left open will depend on a number of factors, such as: ambient temperature, router frame loading, crosspoint routing, etc.
- To ensure correct operation under all conditions, the fan assemblies should be left open for no more than 2 minutes at a time.
- Avoid repeated opening of fan doors. Leave a fan door closed for at least 5 minutes after it has been open for 2 minutes; this restores correct ventilation.
- Take care not to trap any cables when opening and closing the fan doors.

To minimize the time that a router frame's outer front doors and fan doors are open, ensure that you understand which modules need to be changed and where they are located: Refer to your completed [Table 3-2](#) on page 44.

Read through the following installation steps and notes to ensure that you understand them before installing an MV-831.

Module Removal Procedure



CAUTION Electrostatic Damage:

Static precautions must be observed when handling, inserting or removing modules.

Note: Rear module removal requires:

- A Pozidriv screwdriver suitable for pan head, M3 x 6 mm, zinc plated screws.
-

Removal procedure:

- 1 Start at the rear of the router.

To empty *relevant* slots of front modules or rear panels, ready for the MV-831 modules:

- 2 Locate the pair(s) of rear modules to remove.
[Table 3-2](#) on page 44 indicates which modules need to be removed.
- 3 Disconnect all cables connected to rear panel connectors on rear slots to be emptied.

Rear module removal:

- 4 Remove all rear modules for slots that need to be emptied.
Unscrew rear panel securing screws on each module (two or four screws, depending on the module being removed) and then remove the module.

Note: An MV-831 rear panel has handles to assist removal (see [Figure 3-2](#) on page 38).



WARNING

Some rear panels have sharp, pointed locating pins.
MV-831 rear panels have sharp locating pins.

IMPORTANT When removing any module:

Take care not to knock high components mounted on the top- or on the bottom-side of the module or any surrounding modules. Because any knock may damage the module being removed, or the surrounding modules in the router frame.

The relevant rear slots are now emptied.

- 5 Now move to the front of the router.
- 6 Unlock and open the router outer front door and open the relevant internal fan door (refer to Figure 3-5).

Front module removal:

- 7 Locate the pair(s) of front modules to remove. Refer to [Table 3-2](#) on page 44.
- 8 Remove all front modules from front slots that need to be emptied by pulling on the two module eject levers and sliding the module out of the frame. See Figure 3-7.

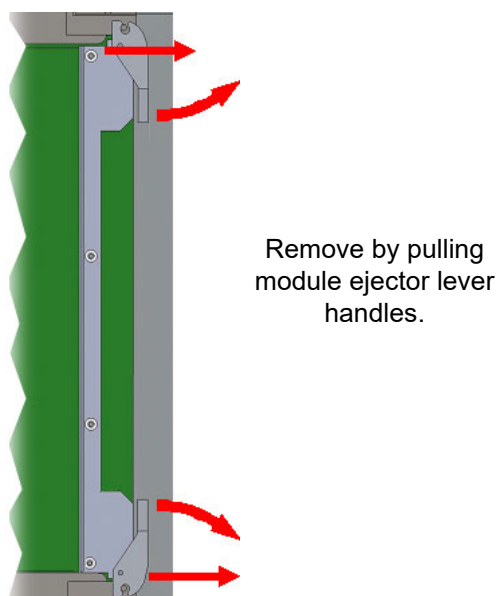

Fig. 3-7: Removing Front Modules, showing use of module eject levers

- 9 Close and secure the internal fan door.
Close and lock the router outer front door.

All relevant slots should now be empty, both front and rear, ready for fitting one or more MV-831 modules.

- 10 Continue immediately to read [Fitting Preliminaries](#), on page 48 before starting [Module Fitting Procedure](#), on page 49.

Fitting Preliminaries



CAUTION **Electrostatic Damage**

Static precautions must be observed when handling, inserting or removing modules.

Rear module fitting requires:

- A Pozidriv screwdriver
- Four pan head, M3 x 6 mm, zinc plated screws per rear module.

IMPORTANT

When inserting a module, take care and do not knock high components which are mounted on the top- or on the under-side of the module.

Any knocks may damage the module being inserted, or the modules above and below it in the router frame.

IMPORTANT

Fit the MV-831 Rear Panel(s) before fitting the front MV-831 Main Module(s).

Note: When inserting a *rear* module into a **rear** slot:

- Check the module is the correct one for the slot.
- Check there are no obstructions at the module connectors.
- Check for any high components on the top- or under-side of the module. Do not knock these during fitting.
- Insert the module into the slot and slide the module into the frame.
- In the last few millimeters of travel, the module connectors mate with the router motherboard. Some resistance will be met; ease, but do not force, the module in.
- If excessive resistance is met, remove the module and re-check that the module and slot are correct. Check the slot for any obstruction. Check the module connectors for any damage or foreign objects.
- Fasten the two module securing screws at the far left and far right of the module's rear plate. Gently tighten the fixing screws. Do not over-tighten them.
- **WARNING:**
Handle and fit with care, the MV-831 rear panel (MV-830-RP) has two sharp, pointed locating pins.

WARNING

Handle and fit with care, the MV-830-RP rear panel has two sharp, pointed locating pins.

Note: When inserting a *front* module into a **front** slot:

- Check the module is the correct one for the slot.
 - Check there are no obstructions at the module connectors.
 - Check for any high components on the module's top- or under-side. Do not knock these during fitting.
 - Insert the module into the slot and slide the module into the frame.
 - When the module is nearly fully in the frame, gently push the module levers, see Figure 3-10.
 - In the last few millimeters of travel, the module connectors mate with the internal router motherboard and its rear panel module.
Some resistance will be met; ease, but do not force, the module in with the levers.
 - If excessive resistance is met, remove the module and re-check that the module and slot are correct. Check the slot for any obstruction. Check the module connectors for any damage or foreign objects.
 - In the final few millimeters of travel, the levers engage with the router frame, locking the module into position
-

Refer to [Table 3-2](#) on page 44 for MV-831 module slot locations.

Module Fitting Procedure

Please ensure that you have read [Fitting Preliminaries](#), on page 48 before proceeding to fit modules.

Rear panel for MV-831 module:

- 1 Go to the **rear** of the router frame.

The procedure begins with the fitting of rear modules:

- 2 Locate the rear slot pairs for **MV-831** fitting.
Refer to [Table 3-2](#) on page 44 for MV-831 module fitting locations.
- 3 Insert an MV-831 Rear Panel module (**MV-830-RP**) into the rear slot pair.
Repeat for each **MV-830-RP** if more than one is being fitted.

Check the orientation of the rear module, see Figure 3-8.

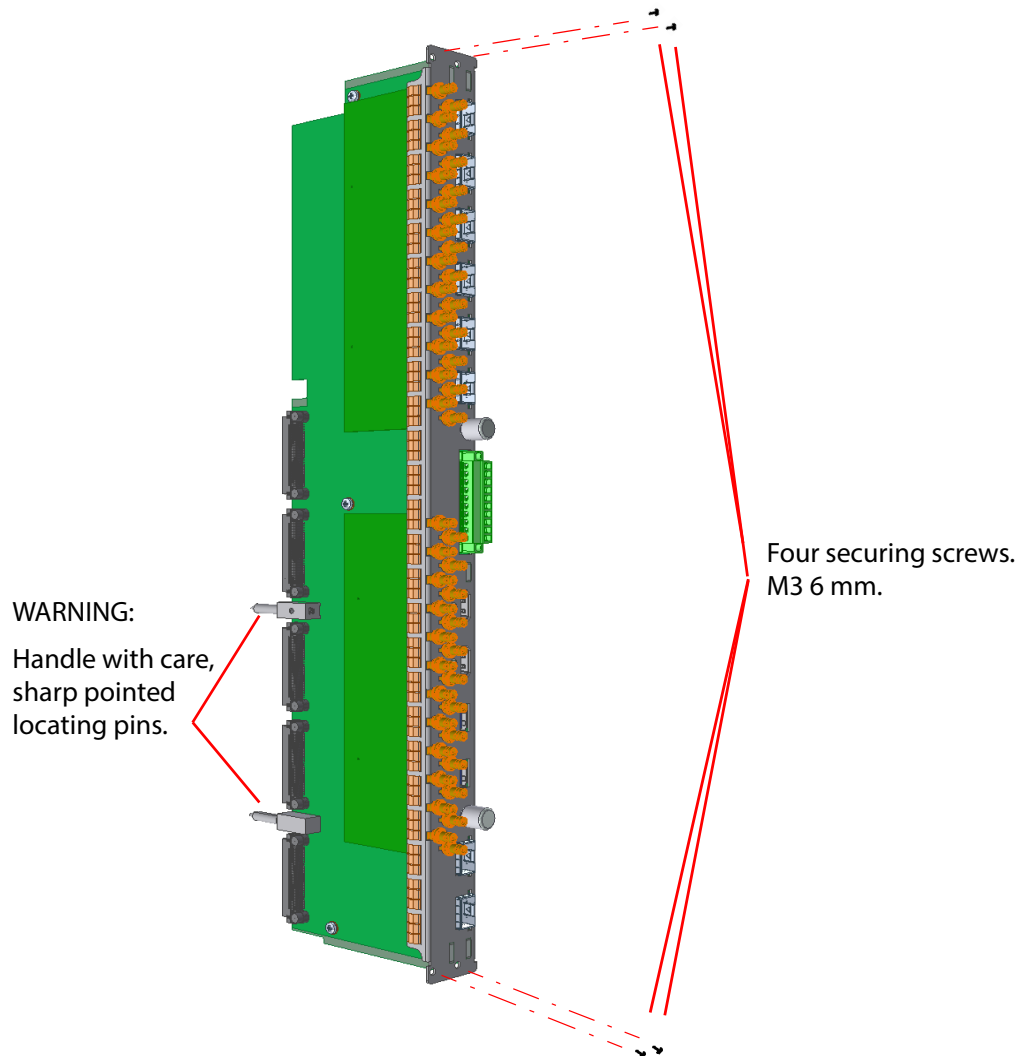

Fig. 3-8: MV-830-RP Rear Panel module

- 4 Fasten the MV-831 rear panel module in position with four securing screws, see Figure 3-8. Do not over-tighten the screws.

IMPORTANT

Do not over tighten the rear panel fastening screws.

- They should screw in without any resistance until the screw head secures the rear panel to the frame.
- If a rear panel fastening screw binds up then it should be removed and the screw and its alignment should be checked before the screw is refitted.

- 5 Fit blanking plates (Figure 3-9) to any remaining empty rear slots. Fasten the two plate-securing screws. Gently tighten the fixing screws. Do not over-tighten them.

IMPORTANT

The risk of non-compliance and overheating is with the user if blanking plates are not fitted in unused rear slots.

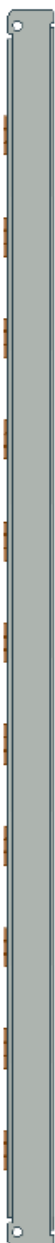
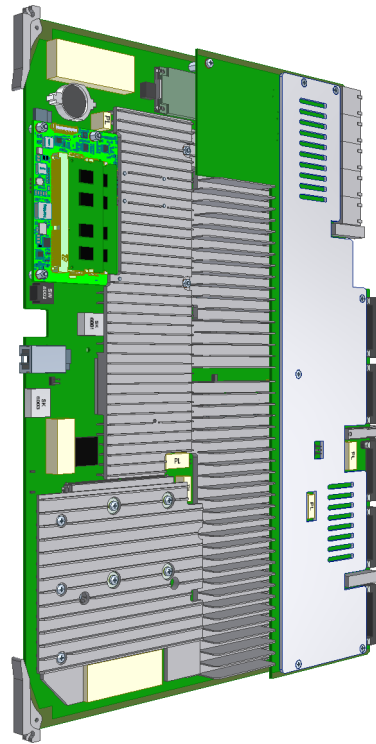

Fig. 3-9: Rear Blanking Panel - for empty rear slots

Rear modules are now fitted.

Front MV-831 module:

- 6 Go to the **front** of the router.
- 7 Locate the corresponding front slot pairs for **MV-831** fitting.
Refer to [Table 3-2](#) on page 44 for MV-831 module fitting locations.



a) MV-831 front module

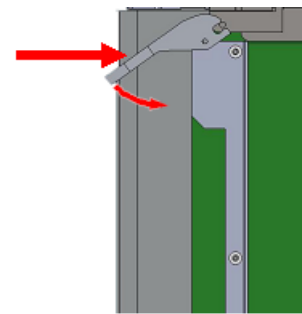

Insert

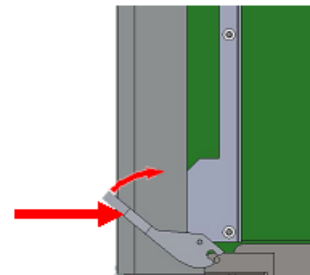

b) Inserting a front module

*Fig. 3-10: Module:
a) MV-831 Front Module; and
b) Inserting a Front Module with Levers*

- 8 Close and secure the front fan door assembly, making sure not to trap any wires.
- 9 Close and lock the router outer front door.

The MV-831 Multiviewer hardware is now fitted in the router frame.

Connecting Cables

Now that the MV-831 Multiviewer hardware is fitted into the router, some cable connections need to be made. Figure 3-11 shows the connections that need to be made.

Note: The MV-831 must initially be configured via its RollCall templates from a computer before being attached to the router's ultimate IT network. See the 'MV-8 Series Multiviewer' user manual for a description of the RollCall templates.

- 1 Connect the MV-831 directly to a computer network port via 1G Ethernet port 1 (see Figure 3-11) using a standard CAT 5e Ethernet cable.
- 2 Connect up to 4 display monitor screens to Multiviewer **Display Outputs** 1 to 4. If more Multiviewer Display Outputs have been licensed, then connect these.
- 3 Connect **SDI Video Inputs** from upstream video equipment outputs.
- 4 Connect **SDI Video Outputs** to downstream video equipment inputs.
- 5 Connect any GPIO and LTC connections.

For a full list of MV-831 input and output connectors and pinouts, see [LTC and GPIO Connector Pin-outs](#), on page 32.

See the 'MV-8 Series Multiviewer' user manual for details on configuring the MV-831.

IMPORTANT **Ensure Ethernet connection:**

Ensure the logical and physical connection of all Ethernet ports to the MV-831 rear panel.

This is required for optimum MV-831 performance.

Explanation:

The MV-831 has more than one Ethernet port, with one IP address per Ethernet port.

However, even if a port is disconnected, its IP address can still be "seen" through other the Ethernet ports.

This means the multiviewer can still *appear* to be operating normally, i.e. with all Ethernet ports connected, even with one or more unconnected network ports.

There is a performance penalty for operating in this way.

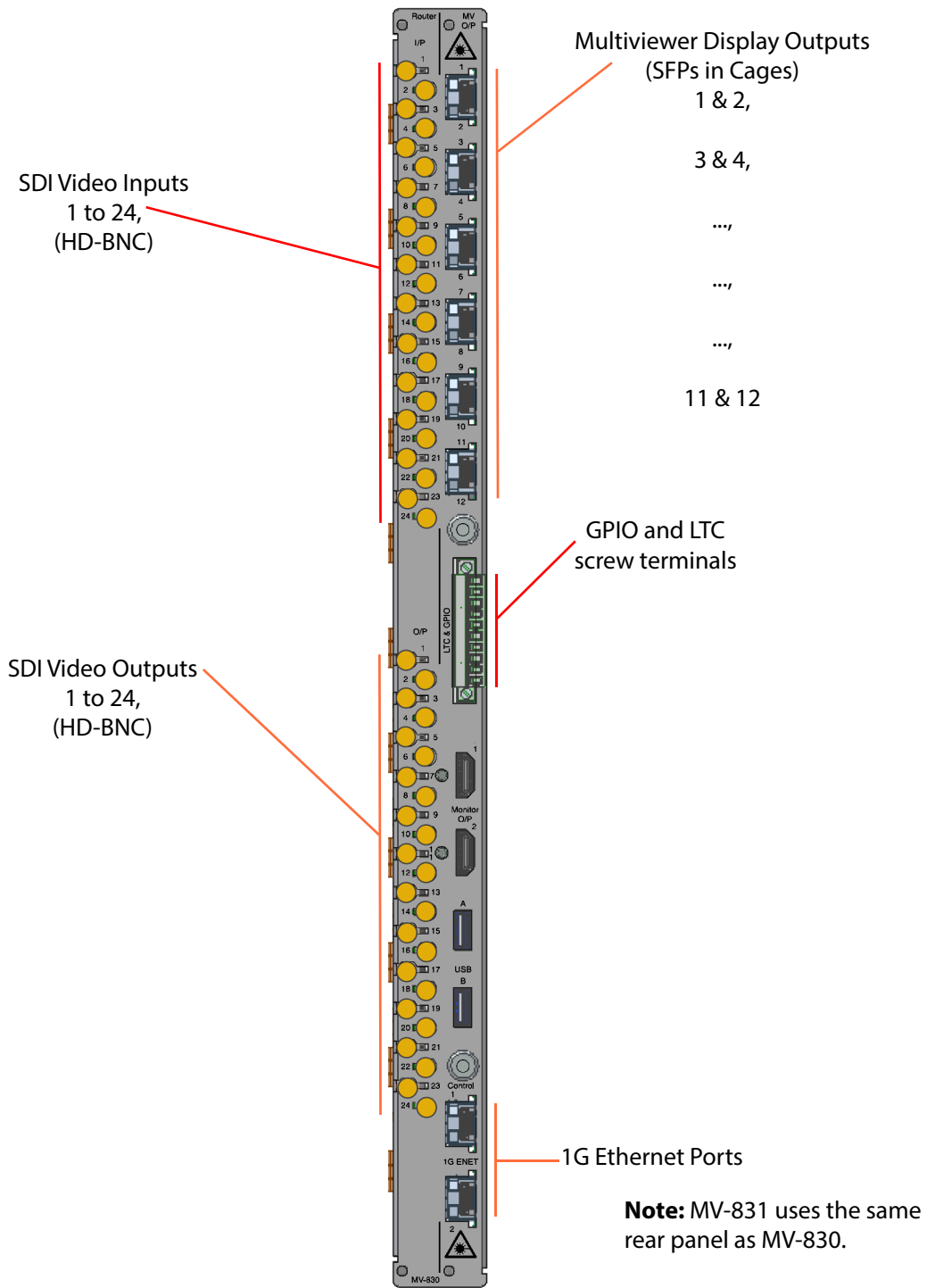

Fig. 3-11: MV-831 Multiviewer Rear Panel Connections (MV-830-RP)

MV-831 Module Booting

Refer to the 'MV-8 Series Multiviewer' user manual for information about MV-831 module booting and start-up splash screen.

Note: Use the '1G1' network interface when performing the initial unit configuration with Grass Valley RollCall control panel.

Note: The 'Eng' interface is a reserved internal IP network interface, do not use this interface.

A Specification

Physical/Electrical

Table A-1:

Power	
Power consumption	250 W
Environmental	
Operating Temperature	5°C to 30 °C ambient.
Relative Humidity	10 to 90% (non-condensing)
Weight	
Front Module	3.5 kg (7.7 lb)
Rear Panel	1 kg (2.2 lb)

Dimensions

MV-831-MB Dimensions

Table A-2:

Dimensions	
Width	435 mm (~ 17.25 in.) approx.
Depth	345 mm (~ 13.6 in.) approx.
Height	32 mm (~ 1.3 in.) approx.

MV-831-RB Dimensions

Table A-3:

Dimensions	
Width	439 mm (~ 17.3 in.) approx.
Depth	135 mm (~ 5.5 in.) approx.
Height	32 mm (~ 1.3 in.) approx.

Inputs

Table A-4:

Router Video Inputs	
Number and type	24-off HD-BNC Coax.
Standards supported	SMPTE-259M 525 and 625 SD-SDI EN50083-9 DVB-ASI (See Note 1) SMPTE 292M 720p and 1080i HD-SDI SMPTE 424M 1080p 3G-SDI
Impedance	75 R
Data rate	3 Mb/s to 3 Gb/s. Standard video rates re-clocked, all other rates auto-bypassed.
Return loss	>15 dB, 10 MHz to 1.5 GHz >10 dB, 1.5 GHz to 3 GHz
Amplitude	800 mV pk-pk nominal
DC offset	<5V
Cable Equalization	Automatic for: Up to 350 m (1150 feet) Belden 1694A at SD rates Up to 200 m (650 feet) Belden 1694A at HD Up to 140 m (460 feet) Belden 1694A at 3G

Note 1: ASI and MV-831:

The Sirius 830 router can switch ASI signals and the router inputs and router outputs of the MV-831 module pass ASI signals. And the presence of ASI is reported to the router controller. The MV-831 fully supports this ASI router functionality.

However, the monitoring 'MV block' on the MV-831 module only supports baseband video signals, i.e. SD/HD/3G signals, and *not* ASI. If an ASI signal is fed to the 'MV Block', then the MV-831 will report a signal loss at the 'MV block'.

Outputs

Router Outputs

Table A-5:

Router Video Outputs	
Number and type	24-off HD-BNC Coax, re-clocked
Standards supported	SMPTE-259M 525 and 625 SD-SDI EN50083-9 DVB-ASI (See Note 1) SMPTE 292M 720p and 1080i HD-SDI SMPTE 424M 1080p 3G-SDI
Impedance	75 R
Data rate	3 Mb/s to 3 Gb/s. Standard video rates re-clocked, all other rates auto-bypassed.
Return loss	>15 dB, 10 MHz to 1.5 GHz >10 dB, 1.5 GHz to 3 GHz
Amplitude	800 mV p-p $\pm 10\%$
Rise/Fall time	<90 ps @ 3G <180 ps @ HD <650 ps @ SD
Timing Jitter	<0.25 UI @ 1.5G and 3G <0.15 UI @ SD
Alignment Jitter	<0.15 UI @ 1.5G and 3G <0.1 UI @ SD
DC offset	0 V ± 0.5 V

Note 1: ASI and MV-831:

The Sirius 830 router can switch ASI signals and the router inputs and router outputs of the MV-831 module pass ASI signals. And the presence of ASI is reported to the router controller.

The MV-831 fully supports this ASI router functionality.

However, the monitoring 'MV block' on the MV-831 module only supports baseband video signals, i.e. SD/HD/3G signals, and *not* ASI. If an ASI signal is fed to the 'MV Block', then the MV-831 will report a signal loss at the 'MV block'.

Multiviewer Head Display Outputs

Table A-6:

Multiviewer Head Display Outputs	
Multiviewer Head Display Outputs	4 to 12 SDI video outputs. HD-BNC Coax or Fiber. <ul style="list-style-type: none"> • Outputs 1 to 4 on standard MV-831. • Outputs 5 to 12, with MV-831 licenses. Optional SFPs: <ul style="list-style-type: none"> • Dual coax SFP. • Dual Fiber SFP. • Single HDMI SFPs. (Up to 6 x HDMI outputs, 1080p)

Table A-6: (continued)

Multiviewer Head Display Outputs	
Video Standard	3G: 1080p or 720p 2.97Gbps. 75 ohm coax.
Frame rate	50, 59.94 & 60 frames per second.
Reference timing	One reference for all outputs. The Head Display Outputs lock, according to multiviewer's reference setting, to one of: <ul style="list-style-type: none"> • Host Router Reference. • Internal Reference (free running).
Video Delay (latency)	Progressive input: <ul style="list-style-type: none"> • 1 input frame + 1 to 3 output frames. Interlaced input: <ul style="list-style-type: none"> • 1 input field + 1 to 3 output frames.

Table A-7:

Output H.264 Streams	<p>Scaled H.264-encoded copies of the multiviewer inputs, licensed on the MV-831 module (MV-831-H264).</p> <p>Each multiviewer input is H.264 encoded to create streamed copies of the 48 inputs. These are streamed out over IP.</p> <p>Note: The H.264 streams do not function for the following slower-frame-rate HD standards:</p> <ul style="list-style-type: none"> • 1080p30 (and slower frame rates); and • 720p30 (and slower frame rates). <p>These streams can be viewed on desktop PCs via the Grass Valley GV Orbit Lite.</p> <p>Applications include:</p> <ul style="list-style-type: none"> • confidence monitoring. • compliance monitoring.
Number	Up to 48-off.
Encoding	H264-encoded streams.

TV Standards

Table A-8:

Video Standard			
3G-SDI: 2.97Gbps	1080p	59.94 Hz	SMPTE 424M/Level A and Level B (Router) SMPTE 424M/Level A (Multiviewer)
	1080p	60 Hz	SMPTE 424M/Level A and Level B (Router) SMPTE 424M/Level A (Multiviewer)
	1080p	50 Hz	SMPTE 424M/Level A and Level B (Router) SMPTE 424M/Level A (Multiviewer)
HD-SDI: 1.485 Gbps	1080i	60 Hz	(ANSI/SMPTE-274M(4) 292M(D))
	1080i	59.94 Hz	(ANSI/SMPTE-274M(5) 292M(E))
	1080i	50 Hz	(ANSI/SMPTE-274M(6)-292M(F))
	1035i	60 Hz	(ANSI/SMPTE-260M-292M(A))
	1035i	59.94 Hz	(ANSI/SMPTE-260M,-292M(B))
	1080p	30 Hz sF	(ANSI/SMPTE-274M(12) as per RP211)
	1080p	29.97 Hz sF	(ANSI/SMPTE-274M(13) as per RP211)
	1080p	25 Hz sF	(ANSI/SMPTE-274M(14) as per RP211)
	1080p	24 Hz sF	(ANSI/SMPTE-274M(15) as per RP211)
	1080p	23.976Hz sF	(ANSI/SMPTE-274M(16) as per RP211)
	1080p	30 Hz	(ANSI/SMPTE-274M(7)-292M(G))
	1080p	29.97 Hz	(ANSI/SMPTE-274M(8)-292M(H))
	1080p	25 Hz	(ANSI/SMPTE-274M(9)-292M(I))
	1080p	24 Hz	(ANSI/SMPTE-274M(10)-292M(J))
	1080p	23.976 Hz	(ANSI/SMPTE-274M(11)-292M(K))
720p	60 Hz	(ANSI/SMPTE-296M(1)-292M(L))	
720p	59.94 Hz	(ANSI/SMPTE-296M(2)-292M(M))	
720p	50 Hz	(ANSI/SMPTE-296M(2)-292M(M))	
SD Video Standards	525	60 Hz/ 59.94 Hz4:3/ 16:9	(ITU-R BT.601-5, ANSI/SMPTE-259M(2))
	625	50Hz4:3/16:9	(ITU-R BT.601-5, ANSI/SMPTE-259M(2))

Reference

Table A-9:

Reference	
Reference Timing	Obtained internally from the host Sirius 830 router frame.

GPI and LTC

Table A-10:

GPI	
Connector	10 Way Screw Terminal type connector. Programmable GPIO Tally with TTL-level/contact-closure inputs for GPI See LTC and GPIO Connector Pin-outs , on page 32 for wiring details and pinout. Note: LTC is also available from the host router.

Ethernet Rear Panel Connectors

Table A-11:

Connectors	
1G Ethernet	2-off 1 Gbps SFP+ cages for Ethernet SFPs. Ethernet socket RJ45. Port 1 and 2.

Table A-12: MV-831 Default IP Addresses, Ethernet Ports 1 to 2

Ethernet port	RollCall Control Panel MV-831 Template	Interface Type	Default IP Address
Port 1	1G1	1G	10.54.31.221
Port 2	1G2	1G	10.54.31.222

Unused Rear Panel Connectors

Table A-13:

Connectors	
Monitor	2-off. Not currently used.
USB	2-off. Not currently used.

Software Versions

Table A-14:

Software	Version
Multiviewer	3.2.22 or later
Router Controller	v5.2.1 (build 7582) or later
Router Door PC	v5.2 or later
Grass Valley WorkBench	v5.2 or later
RollCall Suite	v4.15.62 or later
Grass Valley GV Orbit Lite	1.0.0 or later

Note: For future releases:
Please refer to Multiviewer, GV Orbit and RollCall Control Panel etc.
software release notes for compatibility information.

Router Controller Configuration Items

Table A-15: Router Controller Configuration Item Information

Configuration Item	Value
Module Type - Input	MV830Input
Module Type - Output	MV830Output
Input Ports	MV830
Output Ports	MV830
Logical Sources	VideoSource
Logical Destinations	VideoDest
Router Frame Number	14
EmbeddedTimecodeEnable	True
Multiviewer Monitoring Mode:	
Redundant Crosspoint Enable	Enable/disable to set monitoring mode.
Main Output Follow	(See MV-831 Monitoring Modes , on page 11.)

B Router Slot Information

Table B-1 lists input/output slot information for a Sirius 830 router frame. This includes the input/output module 'slot-pairs' for use by a MV-831. This information is needed when modifying a router controller configuration for MV-831(s) and includes:

- **Module Position Number** - Identifies a module position in the router frame and is used by the router controller.
- **Local Video Port Ranges** - A module in a router input slot or output slot may provide signals to, or use a range of signals from, the router's video crosspoint(s). Ranges:
 - One *source* port range (24 ports) per slot-pair.
 - Two *destination* port ranges per slot-pair:
 - Main crosspoint (24 ports) plus a second (redundant) crosspoint (24 ports).

Table B-1: Sirius 830 - Module Slot Positions, Numbers and Port Ranges

Slot-pairs (See Note 1)		MV-831 Slots	Module Position Number	Local Video Port Ranges (Sirius 830)		
Slot Number	I/O Slot			Input Ports (Source Ports) To Crosspoints	Output Ports (Destination Ports) From Main Crosspoint From Second (Redundant) Crosspoint	
1	Input slot 1		1	1 to 24	-	-
2	Output slot 1		97	-	1 to 24	289 to 312
3	Input slot 2		2	25 to 48	-	-
4	Output slot 2		98	-	25 to 48	313 to 336
5	Input slot 3		3	49 to 72	-	-
6	Output slot 3		99	-	49 to 72	337 to 360
7	Input slot 4		4	73 to 96	-	-
8	Output slot 4		100	-	73 to 96	361 to 384
9	Input slot 5		5	97 to 120	-	-
10	Output slot 5		101	-	97 to 120	385 to 408
11	Input slot 6		6	121 to 144	-	-
12	Output slot 6		102	-	121 to 144	409 to 432
13	Input slot 7		7	145 to 168	-	-
14	Output slot 7		103	-	145 to 168	433 to 456
15	Input slot 8		8	169 to 192	-	-
16	Output slot 8		104	-	169 to 192	457 to 480
17	Input slot 9		9	193 to 216	-	-
18	Output slot 9		105	-	193 to 216	481 to 504
19	Input slot 10		10	217 to 240	-	-
20	Output slot 10		106	-	217 to 240	505 to 528
21	Input slot 11		11	241 to 264	-	-
22	Output slot 11		107	-	241 to 264	529 to 552
23	Input slot 12		12	265 to 288	-	-
24	Output slot 12		108	-	265 to 288	553 to 576

Note 1: Slot Numbering:

- From the *front* of a Sirius 830 router frame, Slot 1 is on the left.
- From the *rear* of a Sirius 830 router frame, Slot 1 is on the right.



Grass Valley Technical Support

For details of our Regional Customer Support Offices please visit the Grass Valley web site at:

<https://www.grassvalley.com/contact/support/>

Customers with a support contract should call their personalized number, which can be found in their contract, and be ready to provide their contract number and details.

For technical assistance, contact our international support center, at 1-800-547-8949 (US and Canada) or +1 530 478 4148.

To obtain a local phone number for the support center nearest you, please consult the 'Contact Us' section of Grass Valley's website (www.grassvalley.com).

An on-line form for e-mail contact is also available from the website.

Corporate Head Office

Grass Valley

3499 Douglas-B.-Floreani

St-Laurent, Quebec H4S 2C6

Canada

Telephone:+1 514 333 1772

Fax:+1 514 333 9828

www.grassvalley.com