



grass valley

A **BELDEN** BRAND

MV-841/851 INTEGRATED MULTIVIEWER

FOR SIRIUS 840/850 ROUTER

User Manual

MV-851-UM Issue 1 Revision 1

2020-May-27

www.grassvalley.com

FCC Compliance

In order to comply with FCC/CFR47: Part 15 regulations, it is necessary to use high-quality, triple-screened Media or Monitor cable assemblies with integrated ferrite suppression at both ends.

Patent Information

This product may be protected by one or more patents.

For further information, please visit: www.grassvalley.com/patents/

Copyright and Trademark Notice

Copyright © 2020, Grass Valley Canada. All rights reserved.

Belden, Belden Sending All The Right Signals, and the Belden logo are trademarks or registered trademarks of Belden Inc. or its affiliated companies in the United States and other jurisdictions. Grass Valley, MV-841/851 Integrated Multiviewer are trademarks or registered trademarks of Grass Valley Canada. Belden Inc., Grass Valley Canada, and other parties may also have trademark rights in other terms used herein.

Terms and Conditions

Please read the following terms and conditions carefully. By using MV-841/851 Integrated Multiviewer documentation, you agree to the following terms and conditions.

Grass Valley hereby grants permission and license to owners of MV-841/851 Integrated Multiviewer to use their product manuals for their own internal business use. Manuals for Grass Valley products may not be reproduced or transmitted in any form or by any means, electronic or mechanical, including photocopying and recording, for any purpose unless specifically authorized in writing by Grass Valley.

A Grass Valley manual may have been revised to reflect changes made to the product during its manufacturing life. Thus, different versions of a manual may exist for any given product. Care should be taken to ensure that one obtains the proper manual version for a specific product serial number.

Information in this document is subject to change without notice and does not represent a commitment on the part of Grass Valley.

Warranty information is available from the Legal Terms and Conditions section of Grass Valley's website.

(See www.grassvalley.com.)

Title MV-841/851 Integrated Multiviewer User Manual

Part Number MV-851-UM

Revision Issue 1 Revision 1 2020-May-27, 15:40

About this Manual

Thank you for purchasing your new MV-841/851 Integrated Multiviewer.

This user manual describes how to install, configure and operate the MV-841/851 multiviewer in the Sirius 840 and 850 routers.

Refer to the appropriate Sirius 800 Router Installation Manuals for details on how to unpack, install and test a Sirius 800 router. Refer to the Sirius 800 Router User Manual for router details. Some of the safety warnings and cautions given the Sirius 800 manuals are repeated in this user manual and are provided herein for information.

If you have any questions regarding the installation and setup of your product, please contact Grass Valley Customer Support.

Related Documents

The following Grass Valley manuals are related documents:

Related Document	Description
User Manual: MV-8 Series Multiviewer	User manual for the multiviewer 'engine' within MV-8X1 Multiviewer products.
User Manual: Sirius 800 Router	User manual for Sirius 800 series routers.
Installation Manuals: Sirius 840, Sirius 850	Installation manuals for Sirius 800 series routers.

Important Safety Information

This section provides important safety guidelines for operators and service personnel. Specific warnings and cautions appear throughout the manual where they apply. Please read and follow this important information, especially those instructions related to the risk of electric shock or injury to persons.

Symbols and Their Meanings



Indicates that dangerous high voltage is present within the equipment enclosure that may be of sufficient magnitude to constitute a risk of electric shock.



Indicates that the user, operator or service technician should refer to the product manuals for important operating, maintenance, or service instructions.



This is a prompt to note the fuse rating when replacing fuses. The fuse referenced in the text must be replaced with one having the ratings indicated.



Identifies a protective grounding terminal which must be connected to earth ground prior to making any other equipment connections.

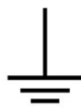

Identifies an external protective grounding terminal which may be connected to earth ground as a supplement to an internal grounding terminal.



Indicates that static sensitive components are present, which may be damaged by electrostatic discharge. Use anti-static procedures, equipment and surfaces during servicing.



Indicates that the equipment has more than one power supply cord, and that all power supply cords must be disconnected before servicing to avoid electric shock.



The presence of this symbol in or on Grass Valley equipment means that it has been tested and certified as complying with applicable Underwriters Laboratory (UL) regulations and recommendations for USA.



The presence of this symbol in or on Grass Valley equipment means that it has been tested and certified as complying with applicable Canadian Standard Association (CSA) regulations and recommendations for USA/Canada.



The presence of this symbol in or on Grass Valley equipment means that it has been tested and certified as complying with applicable Underwriters Laboratory (UL) regulations and recommendations for USA/Canada.



The presence of this symbol in or on Grass Valley equipment means that it has been tested and certified as complying with applicable Intertek Testing Services regulations and recommendations for USA/Canada.



The presence of this symbol in or on Grass Valley product means that it complies with all applicable European Union (CE) directives.



The presence of this symbol in or on Grass Valley product means that it complies with safety of laser product applicable standards.

Warnings



A warning indicates a possible hazard to personnel, which may cause injury or death. Observe the following general warnings when using or working on this equipment:

- Appropriately listed/certified mains supply power cords must be used for the connection of the equipment to the rated mains voltage.
- This product relies on the building's installation for short-circuit (over-current) protection. Ensure that a fuse or circuit breaker for the rated mains voltage is used on the phase conductors.
- Any instructions in this manual that require opening the equipment cover or enclosure are for use by qualified service personnel only.
- Do not operate the equipment in wet or damp conditions.
- This equipment is grounded through the grounding conductor of the power cords. To avoid electrical shock, plug the power cords into a properly wired receptacle before connecting the equipment inputs or outputs.
- Route power cords and other cables so they are not likely to be damaged. Properly support heavy cable bundles to avoid connector damage.
- Disconnect power before cleaning the equipment. Do not use liquid or aerosol cleaners; use only a damp cloth.
- Dangerous voltages may exist at several points in this equipment. To avoid injury, do not touch exposed connections and components while power is on.
- High leakage current may be present. Earth connection of product is essential before connecting power.
- Prior to servicing, remove jewelry such as rings, watches, and other metallic objects.
- To avoid fire hazard, use only the fuse type and rating specified in the service instructions for this product, or on the equipment.
- To avoid explosion, do not operate this equipment in an explosive atmosphere.
- Use proper lift points. Do not use door latches to lift or move equipment.
- Avoid mechanical hazards. Allow all rotating devices to come to a stop before servicing.
- Have qualified service personnel perform safety checks after any service.

Cautions



A caution indicates a possible hazard to equipment that could result in equipment damage. Observe the following cautions when operating or working on this equipment:

- This equipment is meant to be installed in a restricted access location.
- When installing this equipment, do not attach the power cord to building surfaces.
- Products that have no on/off switch, and use an external power supply must be installed in proximity to a main power outlet that is easily accessible.
- Use the correct voltage setting. If this product lacks auto-ranging power supplies, before applying power ensure that each power supply is set to match the power source.
- Provide proper ventilation. To prevent product overheating, provide equipment ventilation in accordance with the installation instructions.

- Do not operate with suspected equipment failure. If you suspect product damage or equipment failure, have the equipment inspected by qualified service personnel.
- To reduce the risk of electric shock, do not perform any servicing other than that contained in the operating instructions unless you are qualified to do so. Refer all servicing to qualified service personnel.
- This unit may have more than one power supply cord. Disconnect all power supply cords before servicing to avoid electric shock.
- Follow static precautions at all times when handling this equipment. Servicing should be done in a static-free environment.
- To reduce the risk of electric shock, plug each power supply cord into separate branch circuits employing separate service grounds.

Electrostatic Discharge (ESD) Protection



Electrostatic discharge occurs when electronic components are improperly handled and can result in intermittent failure or complete damage adversely affecting an electrical circuit. When you remove and replace any card from a frame always follow ESD-prevention procedures:

- Ensure that the frame is electrically connected to earth ground through the power cord or any other means if available.
- Wear an ESD wrist strap ensuring that it makes good skin contact. Connect the grounding clip to an *unpainted surface* of the chassis frame to safely ground unwanted ESD voltages. If no wrist strap is available, ground yourself by touching the *unpainted* metal part of the chassis.
- For safety, periodically check the resistance value of the antistatic strap, which should be between 1 and 10 megohms.
- When temporarily storing a card make sure it is placed in an ESD bag.
- Cards in an earth grounded metal frame or casing do not require any special ESD protection.

Battery Handling



This product may include a backup battery. There is a danger of explosion if the battery is replaced incorrectly. Replace the battery only with the same or equivalent type recommended by the manufacturer. Dispose of used batteries according to the manufacturer's instructions. Before disposing of your Grass Valley equipment, please review the *Disposal and Recycling Information* at:

http://www.grassvalley.com/assets/media/5692/Take-Back_Instructions.pdf

Cautions for LCD and TFT Displays



Excessive usage may harm your vision. Rest for 10 minutes for every 30 minutes of usage.

If the LCD or TFT glass is broken, handle glass fragments with care when disposing of them. If any fluid leaks out of a damaged glass cell, be careful not to get the liquid crystal fluid in your mouth or skin. If the liquid crystal touches your skin or clothes, wash it off immediately using soap and water. Never swallow the fluid. The toxicity is extremely low but caution should be exercised at all times.

Mesures de sécurité et avis importants

La présente section fournit des consignes de sécurité importantes pour les opérateurs et le personnel de service. Des avertissements ou mises en garde spécifiques figurent dans le manuel, dans les sections où ils s'appliquent. Prenez le temps de bien lire les consignes et assurez-vous de les respecter, en particulier celles qui sont destinées à prévenir les décharges électriques ou les blessures.

Signification des symboles utilisés



Signale la présence d'une tension élevée et dangereuse dans le boîtier de l'équipement ; cette tension peut être suffisante pour constituer un risque de décharge électrique.



Avertit l'utilisateur, l'opérateur ou le technicien de maintenance que des instructions importantes relatives à l'utilisation et à l'entretien se trouvent dans la documentation accompagnant l'équipement.



Invite l'utilisateur, l'opérateur ou le technicien de maintenance à prendre note du calibre du fusible lors du remplacement de ce dernier. Le fusible auquel il est fait référence dans le texte doit être remplacé par un fusible du même calibre.



Identifie une borne de mise à la terre de protection. Il faut relier cette borne à la terre avant d'effectuer toute autre connexion à l'équipement.

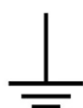

Identifie une borne de mise à la terre externe qui peut être connectée en tant que borne de mise à la terre supplémentaire.



Signale la présence de composants sensibles à l'électricité statique et qui sont susceptibles d'être endommagés par une décharge électrostatique. Utilisez des procédures, des équipements et des surfaces antistatiques durant les interventions d'entretien.



Le symbole ci-contre signifie que l'appareil comporte plus d'un cordon d'alimentation et qu'il faut débrancher tous les cordons d'alimentation avant toute opération d'entretien, afin de prévenir les chocs électriques.



La marque UL certifie que l'appareil visé a été testé par Underwriters Laboratory (UL) et reconnu conforme aux exigences applicables en matière de sécurité électrique en vigueur au Canada et aux États-Unis.



La marque C-CSA-US certifie que l'appareil visé a été testé par l'Association canadienne de normalisation (CSA) et reconnu conforme aux exigences applicables en matière de sécurité électrique en vigueur au Canada et aux États-Unis.



La marque C-UL-US certifie que l'appareil visé a été testé par Underwriters Laboratory (UL) et reconnu conforme aux exigences applicables en matière de sécurité électrique en vigueur au Canada et aux États-Unis.



La marque ETL Listed d'Intertek pour le marché Nord-Américain certifie que l'appareil visé a été testé par Intertek et reconnu conforme aux exigences applicables en matière de sécurité électrique en vigueur au Canada et aux États-Unis.



Le marquage CE indique que l'appareil visé est conforme aux exigences essentielles des directives applicables de l'Union européenne en matière de sécurité électrique, de compatibilité électromagnétique et de conformité environnementale.



Le symbole ci-contre sur un appareil Grass Valley ou à l'intérieur de l'appareil indique qu'il est conforme aux normes applicables en matière de sécurité laser.

Avertissements



Les avertissements signalent des conditions ou des pratiques susceptibles d'occasionner des blessures graves, voire fatales. Veuillez vous familiariser avec les avertissements d'ordre général ci-dessous :

- Un cordon d'alimentation dûment homologué doit être utilisé pour connecter l'appareil à une tension de secteur de 120 V CA ou 240 V CA.
- La protection de ce produit contre les courts-circuits (surintensités) dépend de l'installation électrique du bâtiment. Assurez-vous qu'un fusible ou un disjoncteur pour 120 V CA ou 240 V CA est utilisé sur les conducteurs de phase.
- Dans le présent manuel, toutes les instructions qui nécessitent d'ouvrir le couvercle de l'équipement sont destinées exclusivement au personnel technique qualifié.
- N'utilisez pas cet appareil dans un environnement humide.
- Cet équipement est mis à la terre par le conducteur de mise à la terre des cordons d'alimentation. Pour éviter les chocs électriques, branchez les cordons d'alimentation sur une prise correctement câblée avant de brancher les entrées et sorties de l'équipement.
- Acheminez les cordons d'alimentation et autres câbles de façon à ce qu'ils ne risquent pas d'être endommagés. Supportez correctement les enroulements de câbles afin de ne pas endommager les connecteurs.
- Coupez l'alimentation avant de nettoyer l'équipement. Ne pas utiliser de nettoyeurs liquides ou en aérosol. Utilisez uniquement un chiffon humide.
- Des tensions dangereuses peuvent exister en plusieurs points dans cet équipement. Pour éviter toute blessure, ne touchez pas aux connexions ou aux composants exposés lorsque l'appareil est sous tension.
- Avant de procéder à toute opération d'entretien ou de dépannage, enlevez tous vos bijoux (notamment vos bagues, votre montre et autres objets métalliques).
- Pour éviter tout risque d'incendie, utilisez uniquement les fusibles du type et du calibre indiqués sur l'équipement ou dans la documentation qui l'accompagne.
- Ne pas utiliser cet appareil dans une atmosphère explosive.
- Présence possible de courants de fuite. Un raccordement à la masse est indispensable avant la mise sous tension.
- Après tout travail d'entretien ou de réparation, faites effectuer des contrôles de sécurité par le personnel technique qualifié.

Mises en garde



Les mises en garde signalent des conditions ou des pratiques susceptibles d'endommager l'équipement. Veuillez vous familiariser avec les mises en garde ci-dessous :

- L'appareil est conçu pour être installé dans un endroit à accès restreint.
- Au moment d'installer l'équipement, ne fixez pas les cordons d'alimentation aux surfaces intérieures de l'édifice.

- Les produits qui n'ont pas d'interrupteur marche-arrêt et qui disposent d'une source d'alimentation externe doivent être installés à proximité d'une prise de courant facile d'accès.
- Si l'équipement n'est pas pourvu d'un modules d'alimentation auto-adaptables, vérifiez la configuration de chacun des modules d'alimentation avant de les mettre sous tension.
- Assurez une ventilation adéquate. Pour éviter toute surchauffe du produit, assurez une ventilation de l'équipement conformément aux instructions d'installation.
- N'utilisez pas l'équipement si vous suspectez un dysfonctionnement du produit. Faites-le inspecter par un technicien qualifié.
- Pour réduire le risque de choc électrique, n'effectuez pas de réparations autres que celles qui sont décrites dans le présent manuel, sauf si vous êtes qualifié pour le faire. Confiez les réparations à un technicien qualifié. La maintenance doit se réaliser dans un milieu libre d'électricité statique.
- L'appareil peut comporter plus d'un cordon d'alimentation. Afin de prévenir les chocs électriques, débrancher tous les cordons d'alimentation avant toute opération d'entretien.
- Veillez à toujours prendre les mesures de protection antistatique appropriées quand vous manipulez l'équipement.
- Pour réduire le risque de choc électrique, branchez chaque cordon d'alimentation dans des circuits de dérivation distincts utilisant des zones de service distinctes.

Protection contre les décharges électrostatiques (DES)



Une décharge électrostatique peut se produire lorsque des composants électroniques ne sont pas manipulés de manière adéquate, ce qui peut entraîner des défaillances intermittentes ou endommager irrémédiablement un circuit électrique. Au moment de remplacer une carte dans un châssis, prenez toujours les mesures de protection antistatique appropriées :

- Assurez-vous que le châssis est relié électriquement à la terre par le cordon d'alimentation ou tout autre moyen disponible.
- Portez un bracelet antistatique et assurez-vous qu'il est bien en contact avec la peau. Connectez la pince de masse à une *surface non peinte* du châssis pour détourner à la terre toute tension électrostatique indésirable. En l'absence de bracelet antistatique, déchargez l'électricité statique de votre corps en touchant une surface métallique *non peinte* du châssis.
- Pour plus de sécurité, vérifiez périodiquement la valeur de résistance du bracelet antistatique. Elle doit se situer entre 1 et 10 mégohms.
- Si vous devez mettre une carte de côté, assurez-vous de la ranger dans un sac protecteur antistatique.
- Les cartes qui sont reliées à un châssis ou boîtier métallique mis à la terre ne nécessitent pas de protection antistatique spéciale.

Manipulation de la pile



Ce produit peut inclure une pile de sauvegarde. Il y a un risque d'explosion si la pile est remplacée de manière incorrecte. Remplacez la pile uniquement par un modèle identique ou équivalent recommandé par le fabricant. Disposez des piles usagées conformément aux instructions du fabricant. Avant de vous séparer de votre équipement Grass Valley, veuillez consulter les *informations de mise au rebut et de recyclage* à :

http://www.grassvalley.com/assets/media/5692/Take-Back_Instructions.pdf

Précautions pour les écrans LCD et TFT



Regarder l'écran pendant une trop longue période de temps peut nuire à votre vision. Prenez une pause de 10 minutes, après 30 minutes d'utilisation.

Si l'écran LCD ou TFT est brisé, manipulez les fragments de verre avec précaution au moment de vous en débarrasser. veillez à ce que le cristal liquide n'entre pas en contact avec la peau ou la bouche. En cas de contact avec la peau ou les vêtements, laver immédiatement à l'eau savonneuse. Ne jamais ingérer le liquide. La toxicité est extrêmement faible, mais la prudence demeure de mise en tout temps.

Environmental Information

European (CE) WEEE directive.



This symbol on the product(s) means that at the end of life disposal it should not be mixed with general waste.

Visit www.grassvalley.com for recycling information.

Grass Valley believes this environmental information to be correct but cannot guarantee its completeness or accuracy since it is based on data received from sources outside our company. All specifications are subject to change without notice.

If you have questions about Grass Valley environmental and social involvement (WEEE, RoHS, REACH, etc.), please contact us at environment@grassvalley.com.

Further Safety Information

Lithium Batteries

Battery Warning

CAUTION

This equipment contains a lithium battery.
There is a danger of explosion if this is replaced incorrectly.
Replace only with the same or equivalent type.
Dispose of used batteries according to the manufacturer's
instructions.
Batteries **shall only** be replaced by trained service technicians.

Your Grass Valley equipment usually comes with at least one button battery located on the main printed circuit board. The batteries are used for backup and should not need to be replaced during the lifetime of the equipment.

Battery Disposal

Before disposing of your Grass Valley equipment, please remove the battery as follows:

- 1 Make sure the AC adapter / power Cord is unplugged from the power outlet.
- 2 Remove the protective cover from your equipment.
- 3 Gently remove the battery from its holder using a blunt instrument for leverage such as a screwdriver if necessary. In some cases the battery will need to be desoldered from the PCB.
- 4 Dispose of the battery and equipment according to your local environmental laws and guidelines.

WARNING

- Be careful not to short-circuit the battery by adhering to the appropriate safe handling practices.
- Do not dispose of batteries in a fire as they may explode.
- Batteries may explode if damaged or overheated.
- Do not dismantle, open or shred batteries.
- In the event of a battery leak, do not allow battery liquid to come in contact with skin or eyes.
- Seek medical help immediately in case of ingestion, inhalation, skin or eye contact, or suspected exposure to the contents of an opened battery.

Laser Safety

Laser Safety - Fiber Output SFP and QSFP Modules Warning

LASER SAFETY



The average optical output power does not exceed 0 dBm (1mW) under normal operating conditions. Unused optical outputs should be covered to prevent direct exposure to the laser beam.

Even though the power of these lasers is low, the beam should be treated with caution and common sense because it is intense and concentrated. Laser radiation can cause irreversible and permanent damage of eyesight. Please read the following guidelines carefully:

- Make sure that a fiber is connected to the board's fiber outputs before power is applied. If a fiber cable (e.g. patchcord) is already connected to an output, make sure that the cable's other end is connected, too, before powering up the board.
- **Do not** look in the end of a fiber to see if light is coming out. The laser wavelengths being used are totally invisible to the human eye and can cause permanent damage. Always use optical instrumentation, such as an optical power meter, to verify light output.

Rear Panel Module Handling

IMPORTANT

Take care when handling the MV-841/851 rear panel module:

The rear panel module has some sharp, pointed locating pins. The pins are exposed until the component is fitted into the router frame.

Safety and EMC Standards

This equipment complies with the following standards:

Safety Standards



Information Technology Equipment - Safety Part 1

EN60950-1: 2006

Safety of Information Technology Equipment Including Electrical Business Equipment.

UL1419 (4th Edition)

Standard for Safety – Professional Video and Audio equipment (UL file number E193966)

EMC Standards

This unit conforms to the following standards:

EN55032:2015 (Class A)

Electromagnetic Compatibility of multimedia equipment - Emission requirements

EN61000-3-2:2014 (Class A)

Electromagnetic Compatibility - Limits for harmonic current emissions

EN61000-3-3:2013

Electromagnetic Compatibility - Limits of voltage changes, voltage fluctuations and flicker

EN55103-2:2009 (Environment E2)

Electromagnetic Compatibility, Product family standard for audio, video, audio-visual and entertainment lighting control apparatus for professional use. Part 2. Immunity

WARNING

This equipment is compliant with Class A of CISPR 32. In a residential environment this equipment may cause radio interference.

FCC / CFR 47:Part 15 (Class A)

Federal Communications Commission Rules Part 15, Subpart B

Caution to the user that changes or modifications not expressly approved by the party responsible for compliance could void the user's authority to operate the equipment.

Note: This equipment has been tested and found to comply with the limits for a Class A digital device, pursuant to part 15 of the FCC Rules. These limits are designed to provide reasonable protection against harmful interference when the equipment is operated in a commercial environment.

This equipment generates, uses, and can radiate radio frequency energy and, if not installed and used in accordance with the instruction manual, may cause harmful interference to radio communications.

Operation of this equipment in a residential area is likely to cause harmful interference in which case the user will be required to correct the interference at his own expense.

EMC Performance of Cables and Connectors

Grass Valley products are designed to meet or exceed the requirements of the appropriate European EMC standards. In order to achieve this performance in real installations it is essential to use cables and connectors with good EMC characteristics.

All signal connections (including remote control connections) shall be made with screened cables terminated in connectors having a metal shell. The cable screen shall have a large-area contact with the metal shell.

SIGNAL/DATA PORTS

For unconnected signal/data ports on the unit, fit shielding covers. For example, fit EMI blanking covers to SFP+ type ports; and fit 75 Ω RF terminators to BNC type ports

COAXIAL CABLES

Coaxial cables connections (particularly serial digital video connections) shall be made with high-quality double-screened coaxial cables such as Belden 8281 or BBC type PSF1/2M and Belden 1694A (for 3Gbps).

D-TYPE CONNECTORS

D-type connectors shall have metal shells making good RF contact with the cable screen. Connectors having "dimples" which improve the contact between the plug and socket shells, are recommended.

toc

Table of Contents

FCC Compliance	ii
Patent Information	ii
Copyright and Trademark Notice	ii
About this Manual	iii
Related Documents	iii
Important Safety Information	iv
Further Safety Information	xii
Safety and EMC Standards	xiv
1 Product Overview	1
Benefits of an Integrated Multiviewer	2
Typical User Applications	2
Features	2
MV-841/851 Components	4
Order Codes	5
MV-841/851 and Sirius Router Frame	6
Router Frame Requirements	6
Integration into Sirius 840/850 Routers	6
Monitoring Signals with MV-841/851 in Sirius 840/850	8
Single-frame Sirius 840/850 Systems	8
1152 x 1152 Expansion Sirius 850 Systems	8
Functional	9
Inputs and Outputs	9
Functional Overview	10
Multiviewer Configuration	10
Software and Firmware Compatibility Matrix	11
Multiviewer Terminology	11
MV-841/851 Set up	12
Hardware Installation	12
Router Power Supply Considerations	12
Initial MV-841/851 Configuration	12
Configuration Screens (RollCall Templates)	12
Video Wall Design	13
Maintenance	13
Multiviewer Licensing	13
Multiviewer Software Upgrade	13
MV-841/851 Integrated Multiviewer H.264 Streaming Out	13
2 Hardware Modules	14
Introduction	15
MV-841-MB/MV-851-MB Multiviewer Front Module	16
Status LEDs, Connectors and Switches	17
Status LEDs	18
DIP switches	19
Engineering controls and connectors	19
MV-841/851 Multiviewer Rear Panel (MV-840-RP/MV-850-RP)	20

Connectors.....	22
Rear Panel LEDs	23
Router Video Outputs - Catsii LEDs.....	24
Multiviewer Head Video Display Output LEDs	25
Ethernet Outputs.....	26
LTC and GPIO Connector Pin-outs.....	26
Example: Driving LEDs from the GPI Outputs	28
3 Hardware Installation	29
Introduction.....	30
Unpacking	30
Hardware Installation Steps.....	31
Initial Checks and Actions	32
Router Model Check.....	32
Router Frame Check.....	32
Power Checks	32
Router Configuration	32
Fitting of Video SFPs to MV-841/851 Rear Panel.....	33
Identifying Modules and Slots in Router	35
Removal and then Fitting of Modules	43
Removal Preliminaries	43
Module(s) Removal Procedure	44
Removal Procedure for Rear then Front Modules	44
Fitting Preliminaries	46
Module Fitting Procedure.....	47
Connecting Cables	50
MV-841/851 Module Booting	52
Appendix A Specification	53
Physical/Electrical	53
Dimensions	53
Front Module (MV-841-MB/MV-851-MB)	53
Rear Panel (MV-840-RB/MV-850-RB).....	53
Inputs.....	54
Outputs.....	54
TV Standards	56
GPI and LTC	57
Ethernet Rear Panel Connectors.....	57
Unused Rear Panel Connectors.....	57
Monitoring and Alarms	57
Software Versions	57
Contact Us	59
Grass Valley Technical Support.....	59
Corporate Head Office	59

1

Product Overview

The Grass Valley MV-841 and MV-851 Multiviewers bring a wealth capabilities in an integrated multiviewer: One or more module can be fitted into a Grass Valley Sirius 840 or Sirius 850 router, either as an option on a new Sirius router from the factory, or as a field-installed option. One MV-841 or MV-851 has the video output capability of a pair of Sirius router video output modules and is additionally a multiviewer that can drive up to 12 multiviewer head display monitors, showing up to 48 different video images.

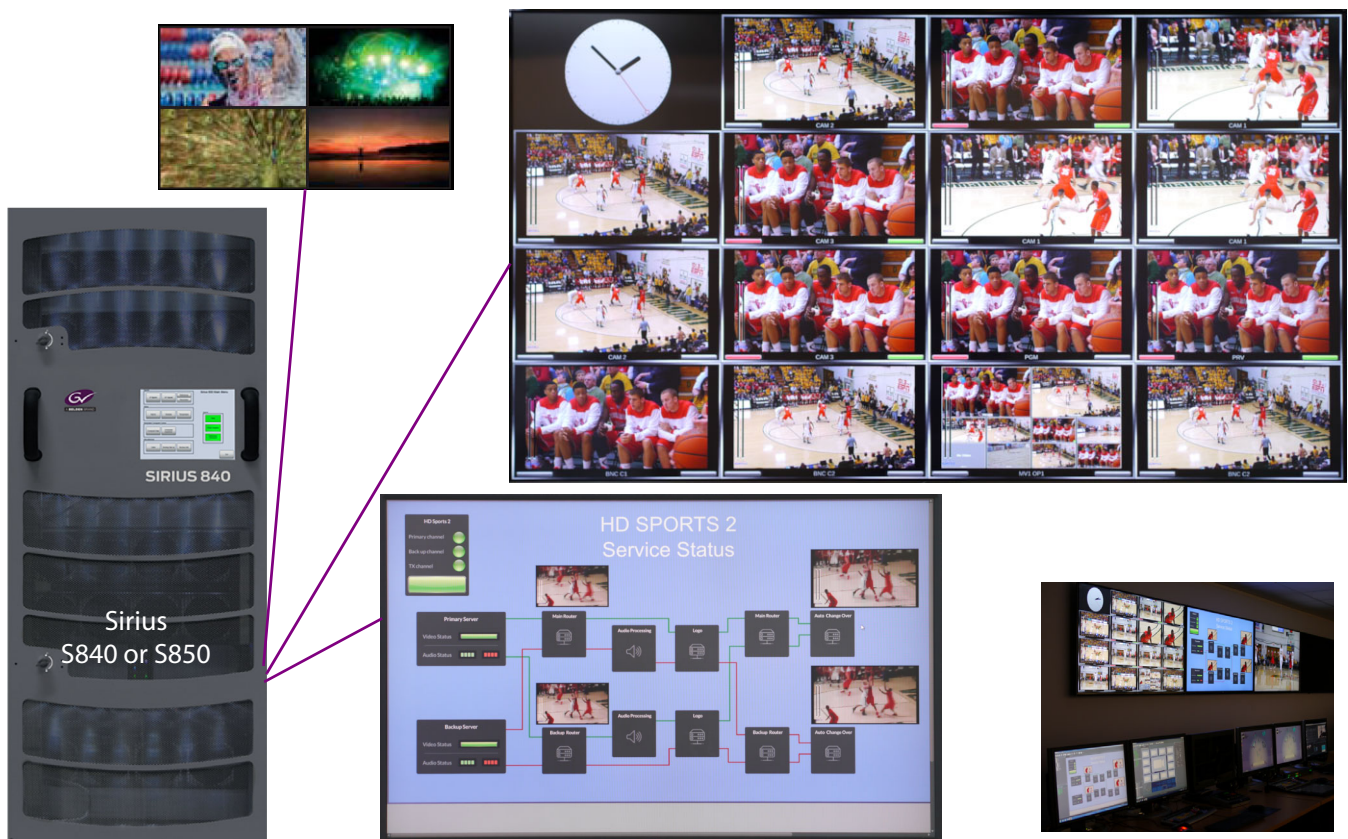

Figure 1 MV-841/851 Integrated Multiviewer Video Walls and Screens (Sirius 840 Router Shown)

The MV-841/851 Integrated Multiviewer is a compact module combining the functionality of:

- 2-off Sirius 840/850 (expandable) standard video output modules (48 outputs).
- 1-off powerful, 48-input 'MV-8 Series' Multiviewer.

MV-841/851 Integrated Multiviewer =

2 x 24 Expandable Video Outputs + Powerful 48-input Multiviewer

Benefits of an Integrated Multiviewer

- No loss of router outputs.
- No additional space is required.
- No extra signal cabling, simplified installation.
- Reduced power consumption and cooling requirements.
- Control and monitoring integration using open protocols.
- H.264 streaming of all video sources on the multiviewer video wall.
- Flexible screen design - multi-channel quad-splits to multi-tile layouts, see Figure 1.

Typical User Applications

The MV-841/851 Integrated Multiviewer is ideal for any user application that requires single or multiple displays. For example: Play out control rooms; Multi-channel play out; Studio galleries; OB trucks; Post-production suites; and Signal lines monitoring areas.

Features

With the development of advanced technology within the MV-841/851 Multiviewer, Grass Valley can offer some unique, powerful multiviewer features:

Integrates into Sirius 840 and 850 systems:

- Replaces a pair of Sirius 800 router output cards in output slots - adds multiviewer capability and retains outputs.
- Accesses up to 48 router video destinations (router outputs). No loss of router outputs, redundancy, or routing capacity.
- Accesses up to 1152 router video crosspoint sources.
- More than one MV-841/851 Integrated Multiviewer per router, see Table 1.

Table 1 MV-841/851 Integrated Multiviewer in Sirius 800 series routers

Sirius 800 Router	Maximum number of fitted MV-841/851's
Sirius 830	N/A, see Note .
Sirius 840	up to 12-off MV-841
Sirius 850	up to 12-off MV-851
2x Sirius 850	up to 24-off MV-851

Note: MV-841/851 Multiviewers do *NOT* fit into Sirius 830 routers.

Multiviewer Video Sources (per MV-841/851):

- Monitor 48 router outputs or any router crosspoint source.
- Sirius 840 – select from the router's 576 inputs, or view 48 outputs.
- Sirius 850 – select from the router's 576 inputs, or view 48 outputs.
- 2x Sirius expansion 850 system – select from the router's 1152 inputs or view 48 outputs.

Advanced broadcast media monitoring:

- Media biometric signature generation for all multiviewer inputs.
- Low-bandwidth video and audio signatures streamed.
- Applications include: Lip sync, Channel mapping detection, Confidence Monitoring. Identification and comparison.
- HDR support.

Up to 12 multiviewer head display outputs per MV-841/851:

- 3G 1080p or HD 720p.
- UHD using four 3G-SDI outputs to provide a UHD quad-link.
- High image quality: De-interlacing, scaling.
- Multiviewer display outputs:
 - 4 display outputs on baseline MV-841/851 model.
 - Expandable to up to 12 display outputs per MV-841/851 module, enabled with additional MV-841/851 licenses.
- Head display outputs use flexible SFP modules.
 - Mixture of 3G SDI dual-coax, dual-fiber, or single-HDMI outputs.

Total screen layout flexibility:

- Flexible video tile arrangements.
- Adjustable layering, transparencies and fine-positioning.
- 48 internal scalers: One per multiviewer input.
- Display status and alarms from external devices.
- Drag and Drop objects onto the screen layout.
- Additionally display web pages, automation play lists, device status screens etc.

Flexible alarm capability:

- Monitoring of video, audio and metadata, with alarm notification.
- Intelligent monitoring of external devices, with configurable on-screen alarms.
- Control and acknowledgment of alarms from hardware- and soft-panels.

Streaming out of Multiviewer Input-Copies (Licensed Option):

- MV-841/851's multiviewer inputs can be scaled and H.264-encoded to create 'MV-input-copies' which can then be streamed out over IP.
- These 'MV-input-copy' video IP streams can be viewed on a desktop PC with appropriate software. See the *MV-8 Series Multiviewer* user manual.

Note: Viewing H.264-encoded video IP streams with GV Orbit:

Grass Valley GV Orbit can be used to form a PC-based streamed video monitoring wall (ideal for secondary monitoring applications). Input H.264 video IP streams, from one or more MV-8X0/8X1 modules, may be displayed on a PC monitor, showing live video, audio levels and alarms.

MV-841/851 Components

One MV-841/851 Multiviewer comprises:

- A double-width front module (MV-841-MB or MV-851-MB).
- A double-width rear module (MV-840-RP or MV-850-RP).

Note: The multiviewer uses the same rear panel modules as the MV-840/50.

SFP modules are ordered separately.

Table 2 lists MV-841/851 Multiviewer component parts.

Table 2 List of Front Modules and Rear Panels etc required for an MV-841/851

Part	Qty	Comment
MV-841-MB or MV-851-MB	1 off	MV-841 or MV-851 Main Module (Front). Licensed for 4-off display outputs. See Note 1 .
MV-840-RP or MV-850-RP	1 off	MV-841 or MV-851 Rear Panel. (Also used on MV-840 and MV-850 multiviewers.) See Note 1 .
SFP video modules:		For head display outputs.
	Up to 6-off per MV-841/851	Mixture of video SFP modules and SFP blanking plugs, depends on MV-841/851 licensing option purchased. (Minimum of: 2-off SFP video output modules + 4-off SFP blanking plugs.) Baseline MV-841/851 is licensed for 2-off SFPs, i.e. 4-off display outputs, enough for one UHD output display. SFPs may be supplied separately or already fitted. SFP types: <ul style="list-style-type: none"> • SM-TT-3G (SDI, dual transmit). • ST31ST31-3 (Fiber). • FC1-HDMI2 (HDMI). • SFPBLANK (Blanking plug).

Note 1: MV-841 and MV-851 are actually identical hardware modules with different order codes:

MV-841-MB is the same as MV-851-MB
and
MV-840-RP is the same as MV-850-RP.

MV-841 and MV-851 are interchangeable.

Order Codes

Table 3 MV-841/851 Order Codes

Order Code	Description
MV-841-MB	MV-841 Multiviewer main (front) module, includes license for 4 display outputs. (Display outputs 1 to 4.)
MV-851-MB	MV-851 Multiviewer main (front) module, includes license for 4 display outputs. (Display outputs 1 to 4.)
MV-840-RP	MV-841 Multiviewer Rear Panel, with SFP cages for accepting SFP video output modules. (Also used on MV-840.) Note: SFPs must be ordered separately.
MV-850-RP	MV-851 Multiviewer Rear Panel, with SFP cages for accepting SFP video output modules. (Also used on MV-850.) Note: SFPs must be ordered separately.

Additional Licenses:

MV-841-H264 MV-851-H264	License to provide the capability to stream out H.264 scaled input-copies of multiviewer video inputs.
--	--

Additional Head Display Outputs:

	Additional display outputs. (A license comprises a supplied code to enable more display outputs.) For MV-841:
MV-841-OP56	Upgrade to enable outputs 5 and 6. SFPs ordered separately.
MV-841-OP78	Upgrade to enable outputs 7 and 8. SFPs ordered separately.
MV-841-OP910	Upgrade to enable outputs 9 and 10. SFPs ordered separately.
MV-841-OP112	Upgrade to enable outputs 11 and 12. SFPs ordered separately.
	For MV-851:
MV-851-OP56	Upgrade to enable outputs 5 and 6. SFPs ordered separately.
MV-851-OP78	Upgrade to enable outputs 7 and 8. SFPs ordered separately.
MV-851-OP910	Upgrade to enable outputs 9 and 10. SFPs ordered separately.
MV-851-OP112	Upgrade to enable outputs 11 and 12. SFPs ordered separately.

SFP Video Modules:

	One SFP video module offers: 2-off SDI outputs (coaxial or fiber); or 1-off HDMI output.
CC-TTH-3G-N	Multiviewer HD-BNC Dual Output SFP module. Grass Valley module number SM-TT-3G.
ST31ST31-3	Multiviewer Fiber Dual Output SFP module (1310 nm, single mode).
FC1-HDMI1	HDMI single output SFP module

SFP Module (Ethernet):

FGAHEY 1GBE-SFP	Ethernet 1GbE SFP.
------------------------	--------------------

SFP Module (Blank):

SFPBLANK	SFP blanking plug (dust and EMC cover).
-----------------	---

MV-841/851 and Sirius Router Frame

Router Frame Requirements

The MV-841/851 Integrated Multiviewer option consists of some hardware modules fitted into front and rear slots of a Sirius 840/850 router frame. The MV-841/851 Multiviewer modules may be purchased already fitted into a new Sirius 840/850 router from Grass Valley or bought separately as a hardware upgrade option, to be fitted to an existing Sirius 840/850 router. One or more MV-841/851's may be fitted to a router.

MV-841/851 router frame requirements are:

- Sufficient router power supply capacity: Contact Grass Valley for advice.
- 2-off adjacent front output module slots.
- + 2-off corresponding rear module slots.

[Hardware Installation](#), on page 29, shows which Sirius router slots are used for the MV-841/851. When fitting the MV-841/851 into an existing router, the relevant router slots may already be used by other Sirius 800 modules and, in this case, those modules need to be removed as part of the MV-841/851 installation (see *Sirius 800 User Manual*). If in doubt, do contact Grass Valley Support, see [Grass Valley Technical Support](#), on page 59.

Additionally, the fitting of one or more MV-841/851 modules into a Sirius router frame affects the frame's operating temperature range. See [Physical/Electrical](#), on page 53.

Integration into Sirius 840/850 Routers

The MV-841/851 Multiviewer modules are double-width modules. A MV-841/851 fits into a *pair* of vertical output front and rear module slots (i.e. 2 front slots and 2 rear slots) in a Sirius 840/850 router frame, see Figure 2. The MV-841/851 module looks like a pair of Sirius standard video output modules to the Sirius router controller system.

More than one MV-841/851 may be fitted into a Sirius 840 or Sirius 850 router.

The MV-841/851 Integrated Multiviewer combines the functionality of:

- 2-off Sirius 840/850 standard router video HD-BNC output cards (expandable)
- +
- 1-off Powerful 48-input multiviewer.

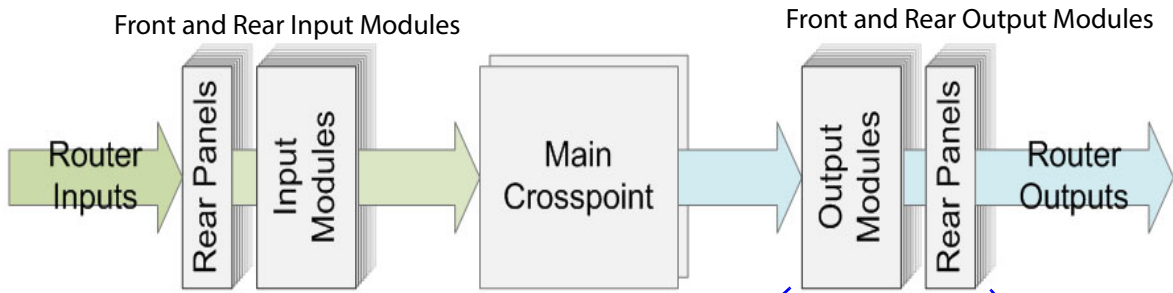

a) Sirius Router - Top Level Diagram

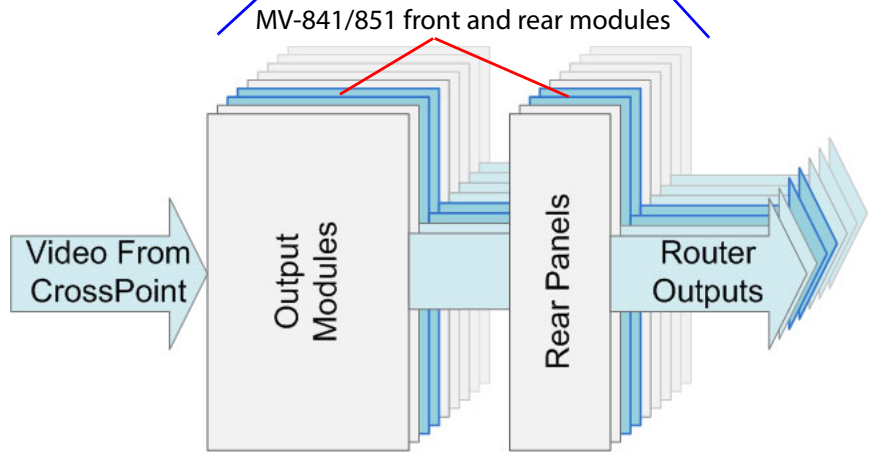

b) Router Front Modules and Output Rear Panels

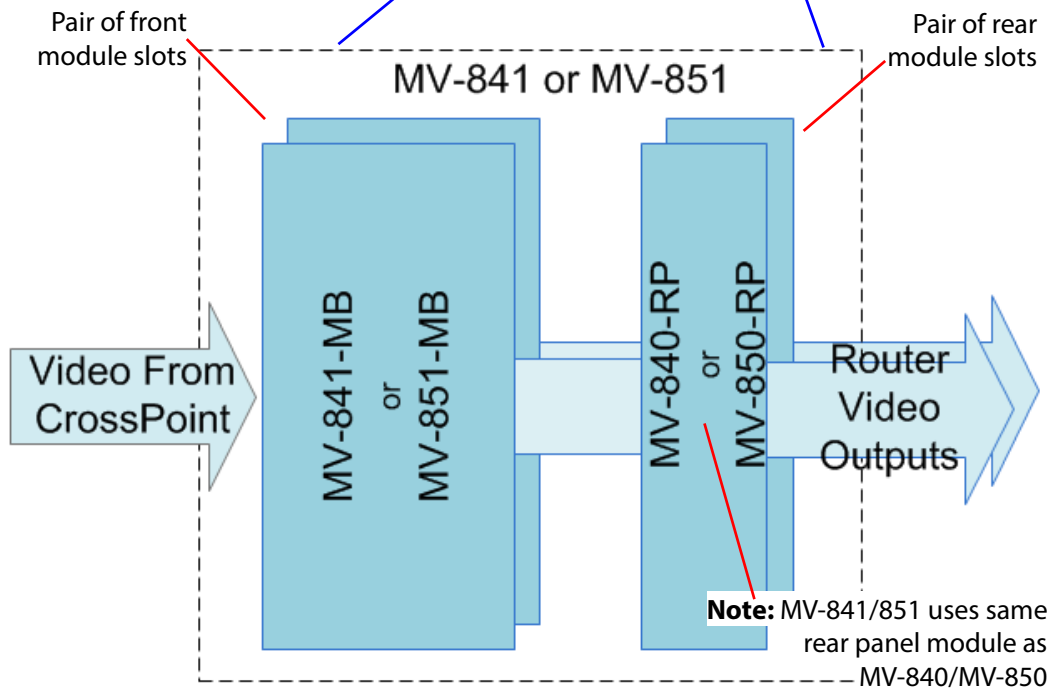

c) MV-841/851 Double-width Output Module (Front module + Rear panel)

Figure 2 MV-841/851 Integrated Multiviewer in Sirius 840/850 Router:
a) Sirius Router - Top Level Diagram.
b) Router Front Modules and Output Rear Panels.
c) MV-841/851 Double-width Output Module (Front module + Rear panel).

Monitoring Signals with MV-841/851 in Sirius 840/850

A simplified diagram of a Sirius router is given in Figure 3. Routed video signals from the router crosspoint are presented as router outputs via the output modules.

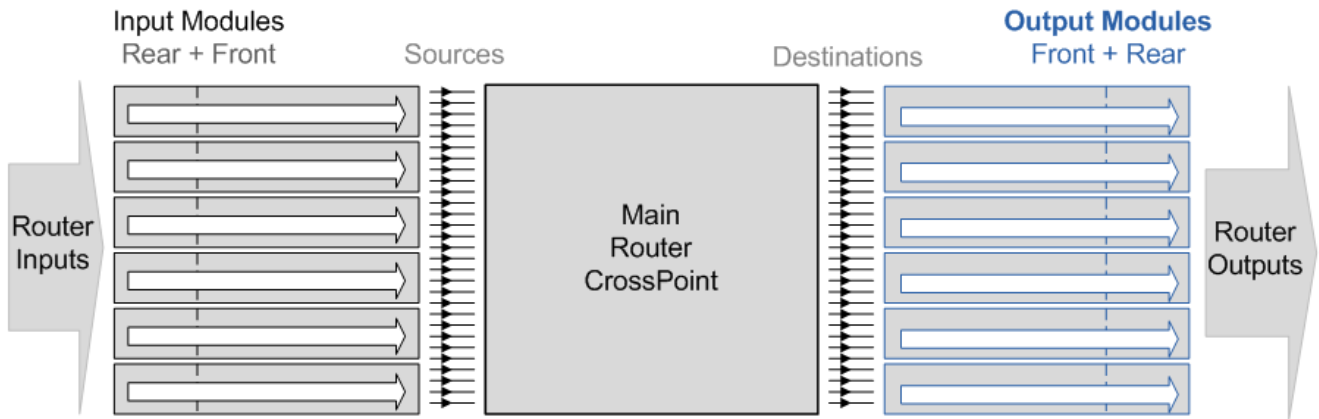

Figure 3 Simplified Sirius 840/850 Router Diagram

The multiviewer monitoring capabilities of an MV-841/851 for single and expanded Sirius router frame systems are described in the following sub-sections.

Single-frame Sirius 840/850 Systems

When an MV-841/851 is fitted to a Sirius 840/850 router, the user can use the multiviewer for monitoring router outputs (destinations) and/or monitoring router inputs (sources) *in any combination*. Figure 4. show an example use case with a combination of router output and input monitoring.

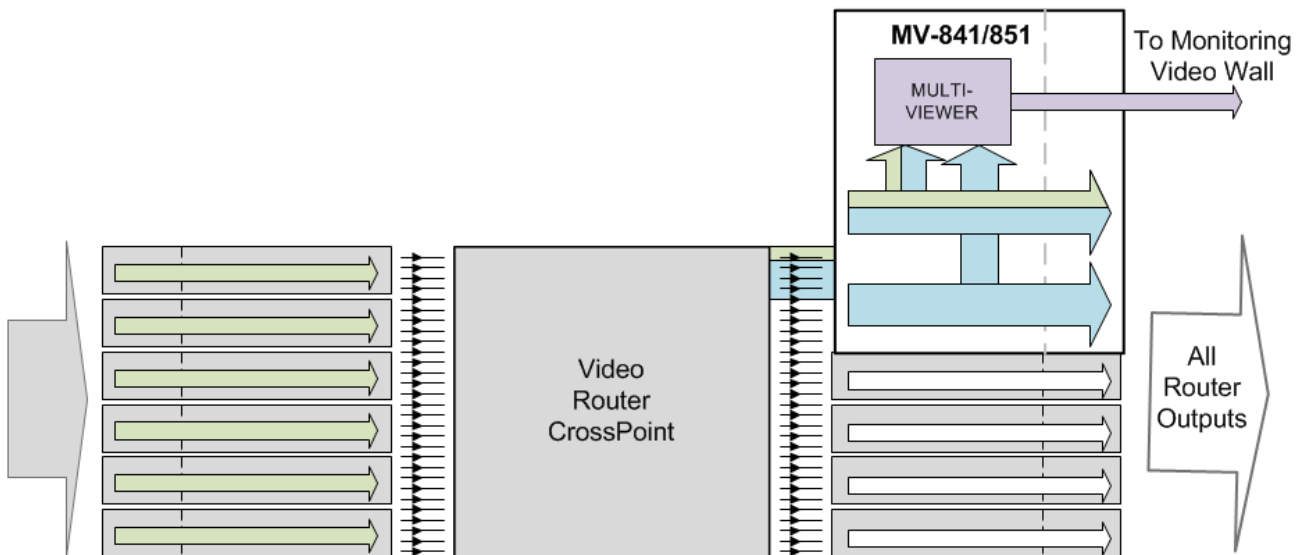

Figure 4 Example Use Case: Monitoring Router Outputs (True Destination Monitoring) and Router Inputs (Source Monitoring)

1152 x 1152 Expansion Sirius 850 Systems

In a Sirius 850 router expansion system, one or more MV-851 multiviewers can be fitted and the user can use the multiviewer to monitor the (larger, expanded) router, monitoring router outputs (destinations) and/or monitoring router inputs (sources) *in any combination*.

Functional

Note:

The MV-841 and MV-851 are identical modules and are, in fact, interchangeable.

Inputs and Outputs

Figure 5 shows the main MV-841/851 inputs and outputs, comprising:

- 48 video inputs: internal, from router crosspoint:
These are the router destinations for the output slots that the MV-841/851 occupies. (See the *Sirius 800 Router User Manual*, section 8.3, for slot numbers and module locations.)
- 48 router video expansion Inputs, DS-Link:
(See the *Sirius 800 Router User Manual*, section 12, for information on router expansion with S850 frames and DS-Link cabling.)
- 48 router video outputs, HD-BNC.
- Multiviewer display outputs:
Up to 6-off SFPs providing up to 12 outputs for monitor display screens. Outputs available in SDI coax, fiber or HDMI. UHD-capable outputs.
Note: There is only one HDMI connector per HDMI SFP. Thus, there are only up to 6 HDMI head display outputs.
- Ethernet connections:
2-off 1G Ethernet ports.
For communications traffic and H.264 streaming out of multiviewer inputs.
- LTC and GPIO.

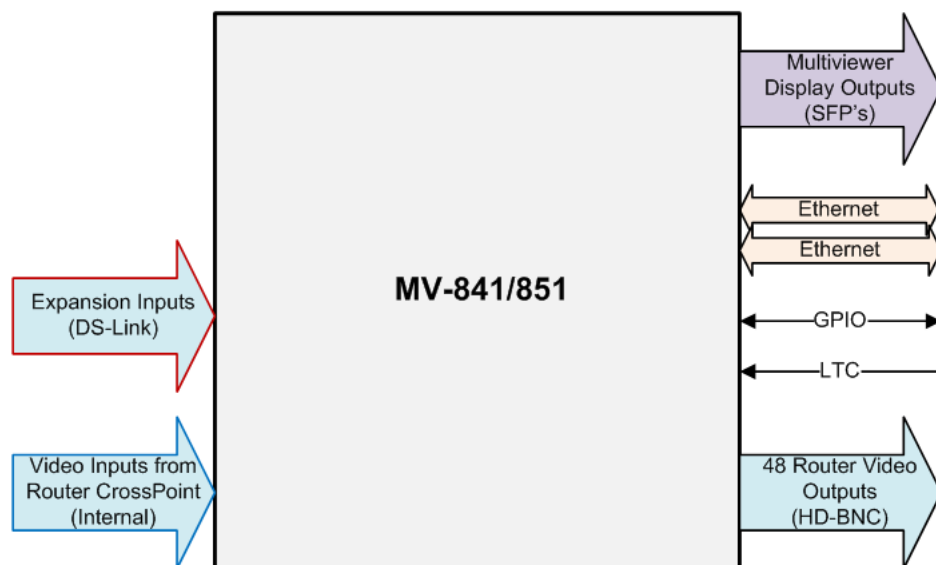

Figure 5 MV-841/851 Module Main Input and Output Signals

Functional Overview

The MV-841/851 Integrated Multiviewer combines the functionality of:

2-off Sirius 840/850 standard video HD-BNC 24 output cards (expandable)

+

1-off Powerful MV-8 Series multiviewer.

The router output function and the multiviewer function of a MV-841/851 module are independent. The output function is the same as a pair of router output modules. See Figure 6.

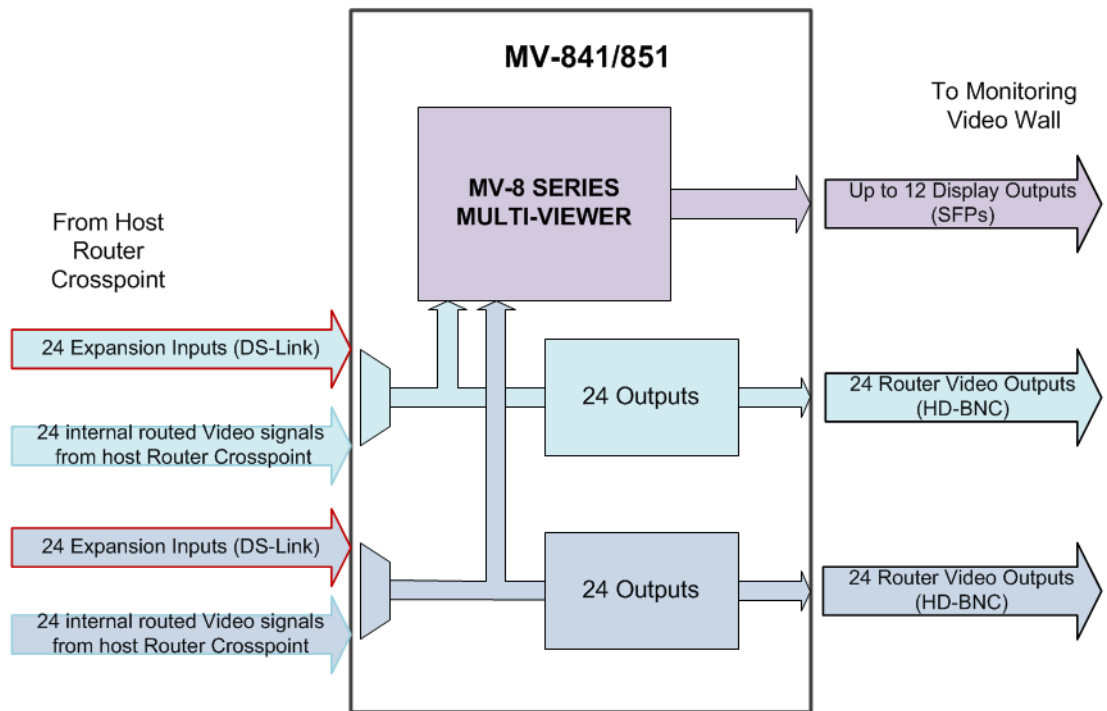

Figure 6 Functional Diagram

Multiviewer Configuration

Router Output Function of MV-841/851:

Setting up of the router output function on the MV-841/851 module is the same as for a standard router output card. See the *Sirius 800 User Manual*.

Router output slots occupied by a MV-841/851 module should be set up as card type:

“Digital Output Video Variant 2”

Multiviewer Function of MV-841/851:

The MV-841/851 module’s multiviewer functionality is a separate, independent sub-system in a host router:

- Configuration of the multiviewer function is done via RollCall templates in RollCall Control Panel (see ‘MV-8 Series Multiviewer’ user manual).
- Design and management of the video wall is done with the GV Orbit tool (see the ‘MV-8 Series Multiviewer’ user manual and the GV Orbit manuals).

Software and Firmware Compatibility Matrix

Table 4 states the compatibility between MV-841/851 and various software and firmware releases.

Table 4 MV-841/851 - Software/Firmware Compatibility Matrix

Software/Firmware Item	Software/Firmware version
RollCall Control Panel	v4.17 or later
Router Controller	Any. See Note 1.
Workbench	Any. See Note 1.
GV Orbit	1.0.0 onwards

Note 1: An MV-841 or MV-851 presents itself to a router system as a pair of Sirius 800 Standard Video Output modules (i.e. video-only, non-AHP modules), for example, as a pair of 5937 modules. Thus, an MV-841/851 is compatible with any version of Router Controller and Workbench tool.

Multiviewer Terminology

Note: For a glossary of multiviewer terminology, refer to the '*MV-8 Series Multiviewer*' user manual.

MV-841/851 Set up

Hardware Installation

Hardware installation is described in Section [“Hardware Installation”](#) on page 29.

Note: Upgrading of the Sirius 800 router controller software is described in the ‘Sirius Maintenance and Upgrade Manual’, Section 9, “Nucleus Upgrade and Maintenance”.

Router Power Supply Considerations

A router’s available power supply capacity depends on:

- the complement of modules already fitted to the router;
- the Power Supply Modules fitted to the router;
- whether the MV-841/851 Integrated Multiviewer(s) replace(s) any currently-fitted modules and their module type.

CAUTION Power supply considerations:

The Sirius router must have enough power supply capacity to power any MV-841/851 modules being fitted.

There are many different Sirius 800 system module and power supply combinations. Therefore, before adding an MV-841/851 to a Sirius 840/850 router, check that the configuration of power supplies fitted to your router can supply sufficient power to the MV-841/851 Multiviewer:

- See the Sirius 800 User Manual for router power requirements.
 - See [Physical/Electrical](#), on page 53 for MV-841/851 power requirements.
 - Contact Grass Valley support for advice.
-

Initial MV-841/851 Configuration

Each MV-841/851 is configured separately.

Typically, a new MV-841/851 will be using a default IP address (10.54.31.221, 10.54.31.226 or 10.54.31.231) on Ethernet port 1 (“1G1”). See [Specification](#), on page 53, Table 13 on page 57, for default IP addresses on all network ports.

Initial configuration and set up of the MV-841/851 multiviewer is done via Grass Valley’s RollCall Control Panel application. See the ‘*MV-8 Series Multiviewer*’ user manual, in the section about RollCall templates and “Getting Started”.

Configuration Screens (RollCall Templates)

Following the initial configuration of the MV-841/851 Multiviewer, the RollCall Control Panel tool may then be used to access RollCall templates and control various MV-841/851 items, including the selection of video wall layouts, monitoring alarm status, acknowledging alarms and control of timer widgets on the video wall.

Refer to the ‘*MV-8 Series Multiviewer*’ user manual for full details of the MV-841/851 module’s RollCall templates and configuration information.

Video Wall Design

The layout and style of the MV-841/851 video walls are designed with the GV Orbit software application. Wall designs are stored as individual projects (GV Orbit projects), which are pushed to an MV-841/851 for use.

Multiple wall layout designs may be generated and stored on a PC. Different wall designs can then be pushed to the multiviewer for various MV-841/851 multiviewer applications.

Note: For information about the design and management of MV-841/851 multiviewer video wall layouts with the GV Orbit application, refer to the '*MV-8 Series Multiviewer*' user manual.

Maintenance

Multiviewer Licensing

Note: For information about licensing the MV-841/851 multiviewer, refer to the '*MV-8 Series Multiviewer*' user manual.

Multiviewer Software Upgrade

Note: For information about software upgrading the MV-841/851 multiviewer, refer to the '*MV-8 Series Multiviewer*' user manual.

MV-841/851 Integrated Multiviewer H.264 Streaming Out

An MV-841/851 has an MV-841/51-H264 license option, which enables streaming out of H.264-encoded copies of the input video signals going to the multiviewer block on the MV-841/851. Streaming is done over Ethernet interfaces 1 or 2. The license option can be added later to MV-841/851 modules in the field.

2

Hardware Modules

Summary:

Hardware Modules

Introduction	15
MV-841-MB/MV-851-MB Multiviewer Front Module	16
Status LEDs, Connectors and Switches	17
Status LEDs	18
DIP switches	19
Engineering controls and connectors	19
MV-841/851 Multiviewer Rear Panel (MV-840-RP/MV-850-RP)	20
Connectors	22
Rear Panel LEDs	23
LTC and GPIO Connector Pin-outs	26
Example: Driving LEDs from the GPI Outputs	28

Introduction

The MV-841/851 Integrated Multiviewer module performs the function of:

- 2-off router output modules with expansion inputs; and
- 1-off multiviewer.

MV-841 or MV-851 module hardware primarily comprises:

- Main front module.
See [MV-841-MB/MV-851-MB Multiviewer Front Module](#) on page 16.
- Rear panel module.
See [MV-841/851 Multiviewer Rear Panel \(MV-840-RP/MV-850-RP\)](#) on page 20.

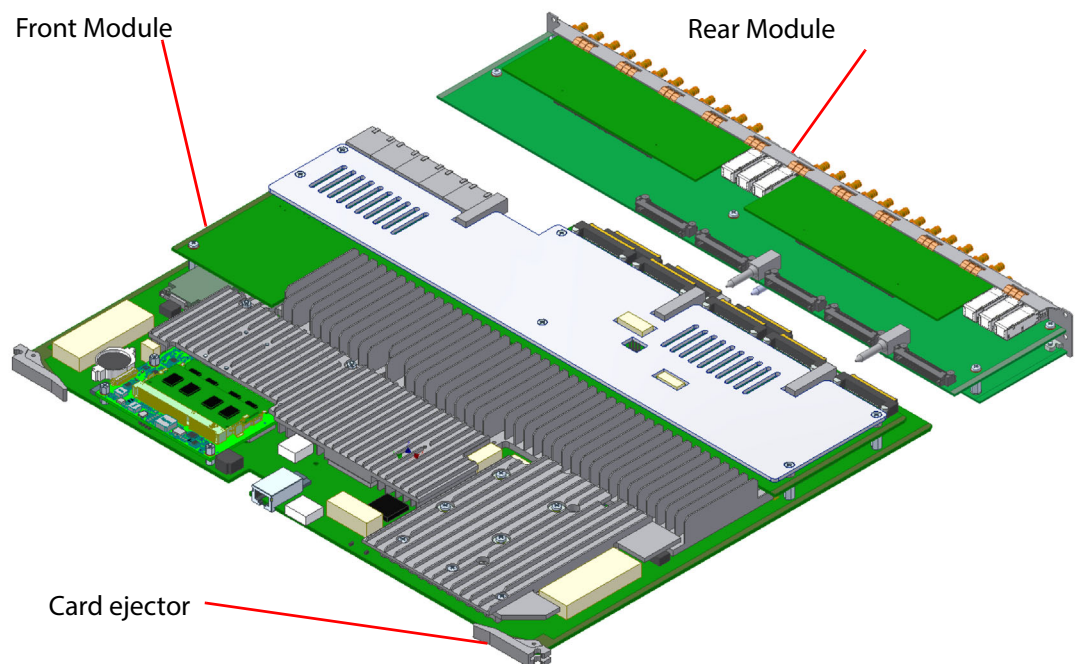

Figure 7 MV-841/851 Multiviewer Front and Rear Modules

The hardware for an MV-841 or an MV-851 module is identical:

- Hardware cards are identical.
- Front modules are both marked on the card ejector with "MV841/51".
- Rear panel modules are both marked "MV840/50" on the silk screen.
(**Note:** These rear panels are also used on the MV-840 and MV-850.)

Note: MV-841 and MV-851 interchangeable:

Although there are different order codes for the integrated multiviewer module for a Sirius 840 router (MV-841-xx) and for a Sirius 850 router (MV-851-xx), the modules are actually identical and interchangeable.

MV-841-MB/MV-851-MB Multiviewer Front Module



CAUTION Electrostatic Damage

Static precautions must be observed when handling, inserting or removing modules.

The MV-841/851 Multiviewer front module is a double-width module, a full-sized Sirius router output front module occupying two (vertical) output slots in a Sirius 840 or Sirius 850 router frame.

The front module assembly comprises a main card, a sub-card and a large gray metal heat plate. These items are not separately serviceable.

The rear panel assembly comprises a main card and two sub-cards. These items are not separately serviceable.

More than one MV-841 or MV-851 may be fitted to a router, see [Table 1](#) on page 2.

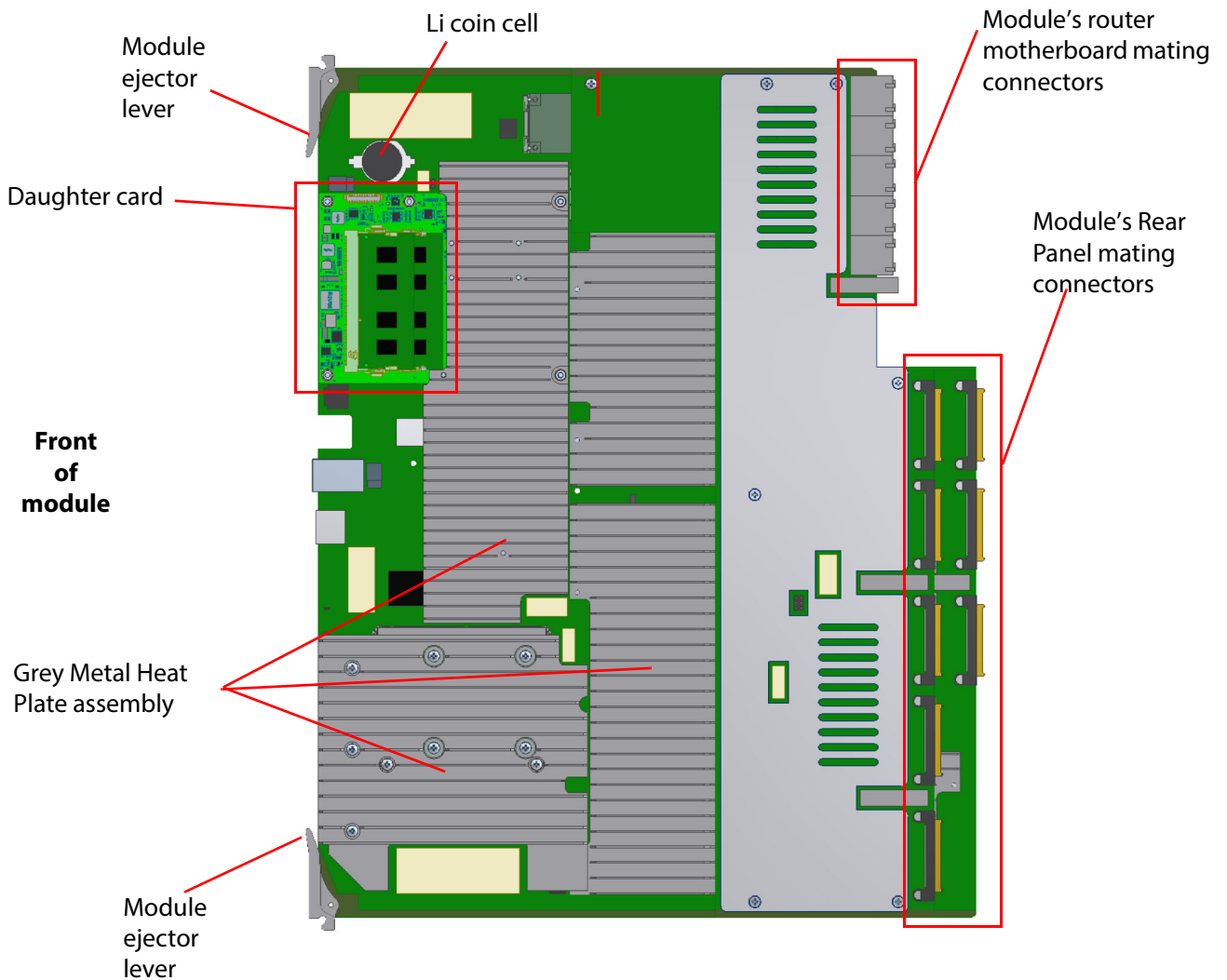

Figure 8 MV-841/851 Multiviewer Front Module

Status LEDs, Connectors and Switches

Figure 9 shows the front edge of the module and Table 5 shows the status LED color codes for the MV-841/851-MB module.

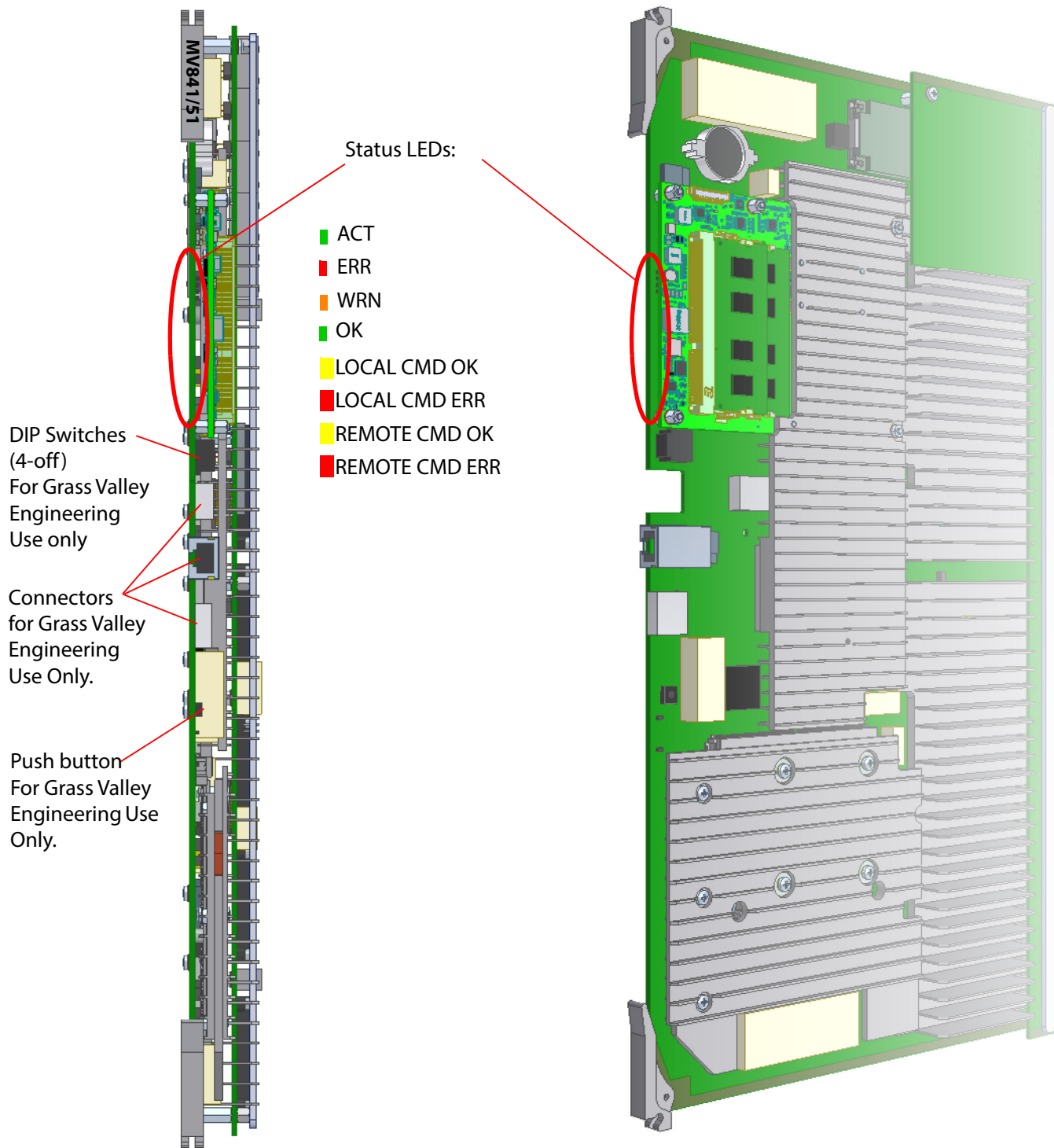

Figure 9 Front LEDs, Connectors and Switches

Status LEDs

Table 5 MV-841/851 Multiviewer Front Module LED Information

Label	LED Color	Detail	Status
ACT	Green	Active Heartbeat	<ul style="list-style-type: none"> Flashing (2Hz): Working correctly. Solid On or Off: Software fault detected. Contact Grass Valley Customer Support (See Grass Valley Technical Support on page 59 for details).
ERR	Red	Error	<ul style="list-style-type: none"> Off: Working correctly. On: Hardware fault detected. Contact Grass Valley Customer Support.
WRN	Amber	Over Temperature Warning	<ul style="list-style-type: none"> Off: Working correctly. On: MV-841/851 module overheating - ensure router fan doors are all closed and the fans are all operating correctly.
OK	Green	Hardware Communications	<ul style="list-style-type: none"> Solid On: Working correctly. Flashing (2Hz): Hardware communications fault detected, contact Grass Valley Customer Support.
LOCAL CMD OK	Yellow	Local Command OK	Receiving command messages from local router controller module. (I.e. a control module in the same router frame.) <ul style="list-style-type: none"> Flashing - receiving information and working correctly. See Note 1.
LOCAL CMD ERR	Red	Local Command Error	<ul style="list-style-type: none"> Off - normal state. Flashing - Command message communication from the local router controller is corrupt or message has not been received. See Note 1 and see Note 2 .
REMOTE CMD OK	Yellow	Remote Command OK	Receiving messages from a remote expansion router controller. (I.e. a control module in expanded router frame linked to this frame.) <ul style="list-style-type: none"> Off - Expansion not used. (I.e. Sirius 840 or 850 with no expansion.) Flashing - Receiving information and working correctly. (For a Sirius 850 router system expanded to a Sirius second frame.) See Note 3 .
REMOTE CMD ERR	Red	Remote Command Error	<ul style="list-style-type: none"> Off - Expansion not used. (I.e. for Sirius 840 and 850 with no expansion') Off - Normal state for Sirius 850 expanded to second frame. Flashing - Command message communication from remote expansion router controller is corrupt or message has not been received. See Note 3 . See Note 2 and Note 4 .
Note 1:	If both "LOCAL CMD ERR" LED is flashing <i>and</i> "LOCAL CMD OK" LED is also flashing, it suggests a mismatch in configuration of router controller. Check the router controller configuration.		
Note 2:	A communications error could be caused by a hardware failure or incorrect module insertion. Check module is inserted correctly.		
Note 3:	If both the "REMOTE CMD ERR" LED is flashing and the "REMOTE CMD OK" LED is also flashing, it suggests a mismatch in the configuration of the router controller. Check the controller configuration.		
Note 4:	A communications error could be caused by a hardware failure or incorrect cable insertion. Check the four RJ45 connections between the two router frames are fitted correctly. (See <i>Sirius 800 User Manual</i> , section 12, Expansion.)		

DIP switches

The four DIP switches are not used. Check that all four switches are in the “up” position.

Engineering controls and connectors

These control and connectors are for Grass Valley Engineering use only.

There is a push button on the front edge of the board. This is for engineering use only.

There are other connectors on the front edge of the module, see Figure 9. These are for Engineering use only and should not be used.

MV-841/851 Multiviewer Rear Panel (MV-840-RP/MV-850-RP)

Note: These rear panels are also used on the MV-840 and MV-850.



CAUTION **Electrostatic Damage**

Static precautions must be observed when handling, inserting or removing modules.

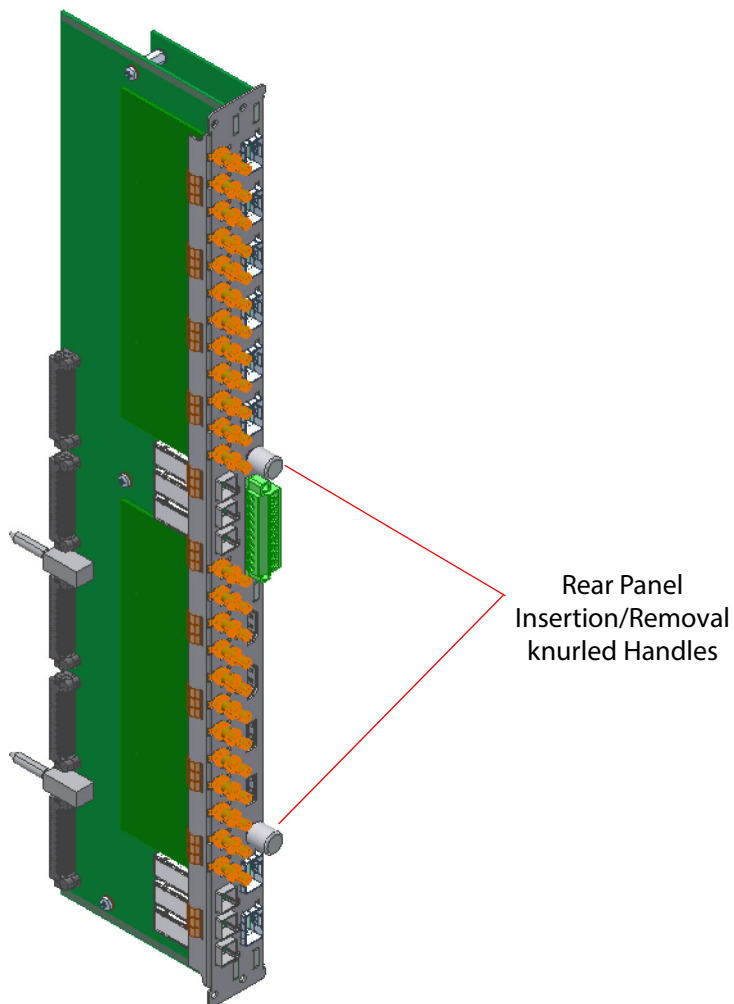

Figure 10 MV-841/851 Multiviewer Rear Panel (Also used on MV-840 and MV-850)

The MV-851 (or MV-841) multiviewer, when fitted into a Sirius 850 router frame, can receive video expansion signals from a second, linked, Sirius 850 frame. (See Sirius User Manual, Section 12 for details about S850 router expansion.)

The module can provide up to 12 multiviewer video display outputs, providing multiviewer video wall outputs.

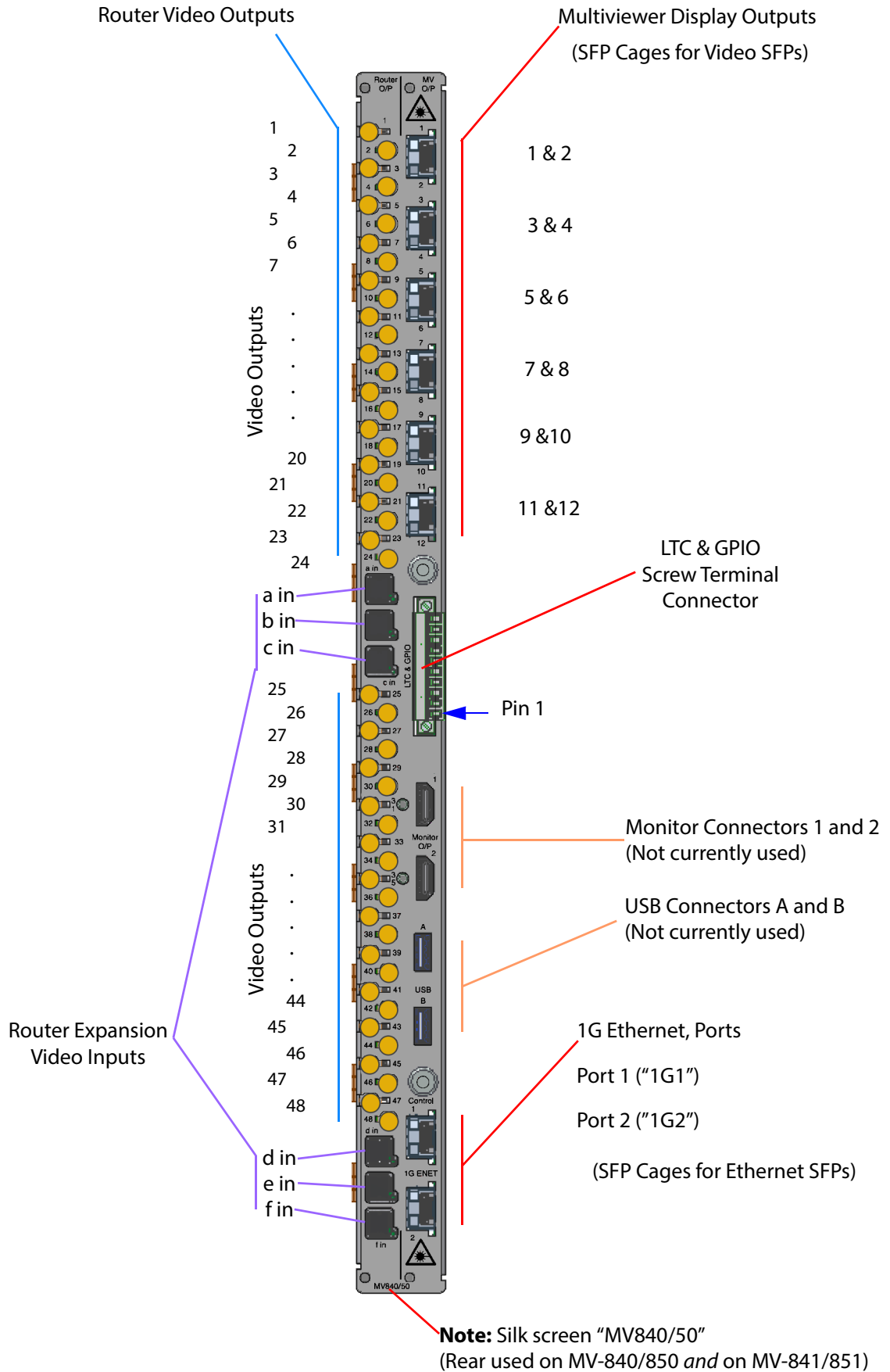

Figure 11 MV-841/851 Multiviewer Rear Panel Rear Connectors

The MV-841/851 rear connectors relate to either the module's router output function or to the module's multiviewer function:

- 48 router video outputs.
- 48 router expansion video inputs.
- Up to 12 multiviewer display outputs from the MV-841/851:
 - 2 outputs per SDI coax or fiber video SFP module.
 - 1 output per HDMI video SFP module.
- Ethernet ports for multiviewer video wall control.
- LTC and GPIO multiviewer connections.

The multiviewer Display Outputs come from video SFP modules fitted into the SFP cages on the MV-841/851 Rear Panel. SFP blanking plugs must be fitted if an SFP is not fitted into any of the cages.

Connectors

Table 6 describes each connector type.

Table 6 MV-841/851 Multiviewer MV-840/850-RP Rear Panel Connectors

Connector	Description
Router Output Function:	
Router Video Outputs	2x 24-off HD-BNC.
Router Expansion Video Inputs	2x 3-off 8-way DS-Link expansion inputs. See Sirius User Manual, Section 12 for details of router Expansion and DS-Link cables etc.
Multiviewer Function:	
Multiviewer Head Display Outputs 1 to 12	Multiviewer video wall outputs. 6-off SFP cages for SFP modules [See Note 1]: <ul style="list-style-type: none"> • 2-off SDI Coax outputs per SFP, • or 2-off SDI Fiber outputs per SFP, • or 1-off HDMI output per SFP.
Multiviewer Monitor Connectors 1 and 2	Not currently used
USB connectors A and B	Not currently used
LTC & GPIO Connector	Screw terminals. See Table 10 on page 27 for pin-out details.
1G Ethernet Ports 1 and 2	2-off 1 Gbps, SFP+ Ethernet sockets, RJ45
Note 1: SFP blanking plugs must be fitted if no SFP is present.	

Rear Panel LEDs

Some rear connections include status LED indicators, see Figure 12.

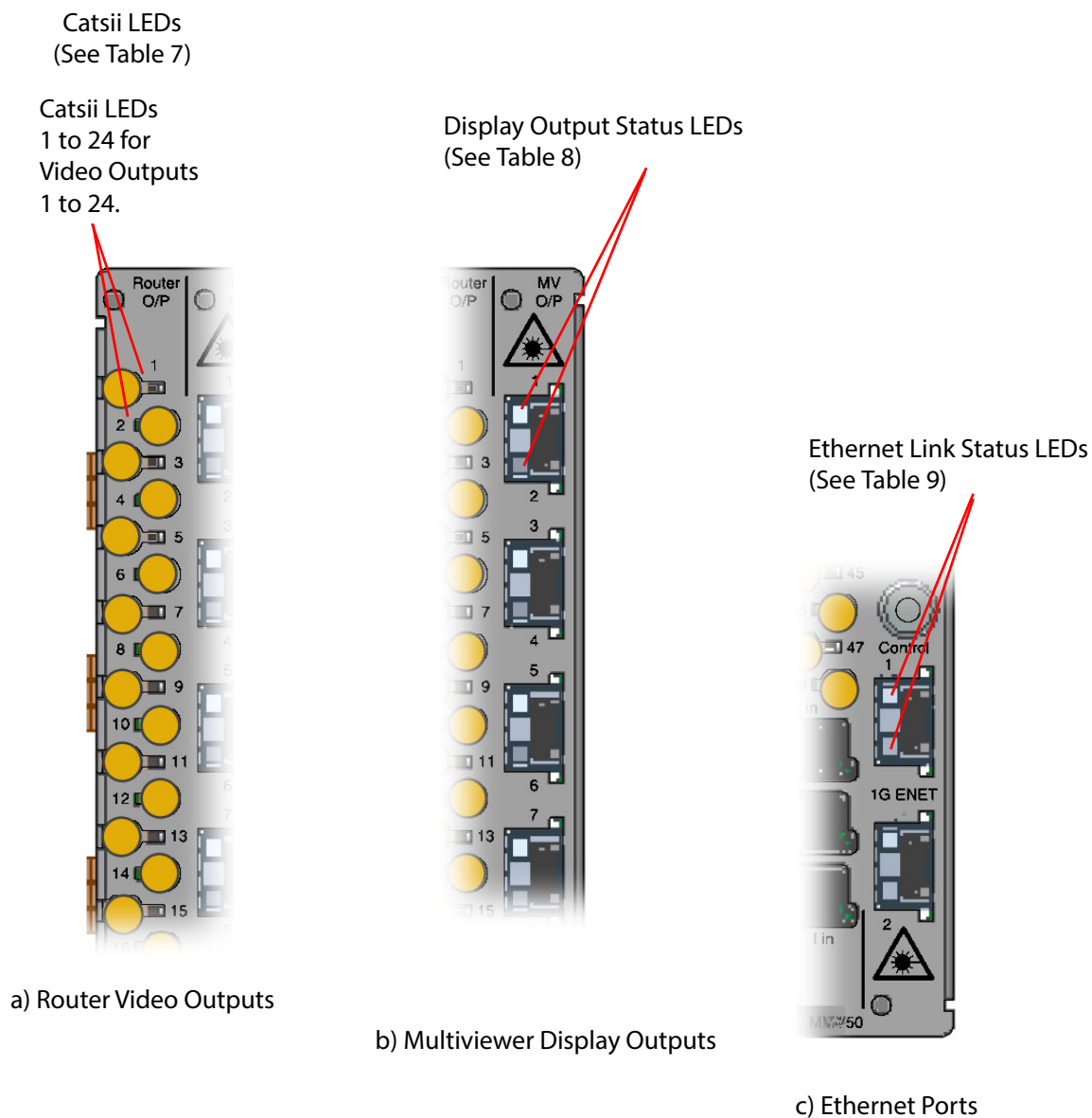

Figure 12 MV-841/851 Rear Panel LEDs:
a) Router Video Outputs and Catsii LEDs.
b) Multiviewer Video Display Outputs.
c) Ethernet Ports.

Router Video Outputs - Catsii LEDs

All the HD BNC connectors on the output rear panel have Grass Valley's unique Catsii LED feature that illuminate at each connector, one LED per output connector. The Catsii LEDs operate in one of two mutually-exclusive modes:

1. To indicate signal status.
2. To identify a specific HD BNC connector.

See the Sirius 800 User Manual, Section 6 "Catsii Functionality" for full details of the Catsii feature.





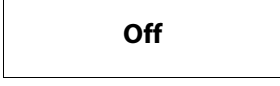

Table 7 Router Video Output Catsii LEDs

Catsii LED	Description
Signal Status Indication mode:	
Red	No valid signal
Yellow	Valid SD signal
Flashing Yellow	DVB-ASI Signal
Green	Valid 1080i or 1080p (30 Hz or lower) HD signal
Flashing Green	Valid 720p HD signal
Blue	Valid 3G signal
Connector Identification mode:	
Yellow	Indicates row or column of connector to be identified.
Flashing Red/Yellow	Connector to be identified.

Multiviewer Head Video Display Output LEDs

One status LED per output, 2 coax or fiber outputs per SFP. Table 8 describes the LED function.

Table 8 Video Display Output Status LED

LED Color	Status
	Licensed Output; SFP Fitted. 1080p video output signal.
	Flashes Blue/White at 1Hz. Licensed Output; SFP Fitted. 1080p video output with embedded audio.
	Licensed Output; SFP Fitted. 720p video output signal.
	Flashes Green/White at 1Hz. Licensed Output; SFP Fitted. 720p video output with embedded audio.
	Licensed Output; No SFP Fitted.
	Unlicensed output.
	Flashes Red/Green at 1Hz <i>during</i> an internal FPGA upgrade (part of a unit software upgrade).
	Flashes Red/Off at 1Hz <i>after</i> a unit software upgrade if: <ul style="list-style-type: none"> • Internal FPGA upgrading was unsuccessful. or • Internal FPGAs fail to load during unit boot. <p>Note: A unit upgrade to the same version may be carried out to recover a unit if FPGA upgrading was unsuccessful. Otherwise, contact Grass Valley support.</p>

Ethernet Outputs

Two status LEDs per port. Table 9 describes the LED function.

Table 9 Ethernet Port LEDs

LED Color	Status
Green	Ethernet link established.
Off	
Green	Activity on Ethernet link
Flashing Green	
Off	Establishing link, or unconnected.
Off	

LTC and GPIO Connector Pin-outs

The MV-841/851 module has the facility for LTC and GPIO signals at its rear panel.

Note: LTC is also available from the host router and is selected via the MV-841/851 module’s RollCall templates.
(See the ‘MV-8 Series Multiviewer’ user manual.)

Female high density 26 way 'D' type connector assignments

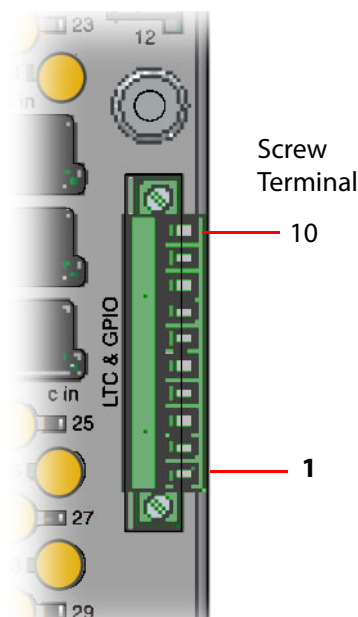

Figure 13 LTC and GPIO Connector, 10-way Screw Terminal

Table 10 gives the pin assignments for the LTC and GPIO connector.

Table 10 Screw Terminal Connector for LTC and GPIO

Screw Terminal Number	Signal
1	GPI 1
2	GPI 2
3	GPI 3
4	GPI 4
5	+5 VDC Out
6	GND
7	LTC+
8	LTC-
9	nc
10	nc

Note: 'nc' denotes a "not connected" terminal.

Note: MV-841/851 GPI outputs - Open collector outputs. Require external pull-up resistors of value between 10 k Ω and 100 k Ω . Each output can sink up to 100 mA.

- "+5 Vdc Out" pins are provided on the connector for this purpose.
- Maximum voltage, +5 V.
- See Section "Example: Driving LEDs from the GPI Outputs" for an example of how GPI outputs can be used to drive LEDs.

MV-841/851 GPI inputs - Inputs have weak internal pull-down resistors.

- Can be driven by input voltages of up to +5 V.
- A logic "low" input is represented by an input voltage below +0.8 V.

Example: Driving LEDs from the GPI Outputs

MV-841/851 GPI outputs have open collector drivers. There is a +5 V DC screw terminal on the GPIO connector to provide the power needed to drive LEDs or relays.

The following schematic is an example of the circuit needed to drive an LED by each GPI output. MV-841/851 GPIO connector pin names and numbers are shown on the left.

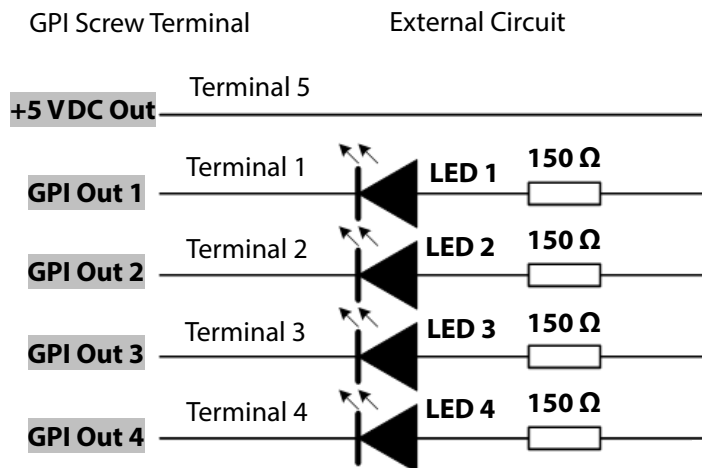

Figure 14 Connecting LEDs to GPI Outputs



CAUTION Electrostatic Damage

Static precautions must be observed when inserting and removing cards.

3 Hardware Installation

Summary:

Hardware Installation

Introduction	30
Unpacking	30
Hardware Installation Steps	31
Initial Checks and Actions	32
Router Model Check	32
Router Frame Check	32
Power Checks	32
Router Configuration	32
Fitting of Video SFPs to MV-841/851 Rear Panel	33
Identifying Modules and Slots in Router	35
Removal and then Fitting of Modules	43
Removal Preliminaries	43
Module(s) Removal Procedure	44
Fitting Preliminaries	46
Module Fitting Procedure	47
Connecting Cables	50
MV-841/851 Module Booting	52

This section describes the installation of an MV-841/851 Multiviewer hardware module into a Sirius 840/850 router. Hardware installation can be carried out while the Sirius router is operating, without impacting the main routing function.

Introduction

Installation of the MV-841/851 Multiviewer hardware can be carried out while the Sirius 800 router is operating, without impacting the main routing function.

Installation instructions are identical for MV-841 and MV-851 integrated multiviewer modules.

Note: If your Sirius 800 router has been purchased from Grass Valley with MV-841/851(s) already fitted, then the MV-841/851 hardware installation task just comprises making connections to the MV-841/851 Rear Panel at the rear of the router (see [Connecting Cables](#), on page 50).

If the MV-841/851 is being fitted to an existing, installed router, then the router frame's module slots for the MV-841/851 hardware must be identified. Slot identification is part of the MV-841/851 hardware installation instructions contained in this section.



CAUTION Electrostatic Damage
Static precautions must be observed when handling, inserting or removing modules.

More than one MV-841/851 unit may be fitted to a Sirius 840/850 router and these instructions cover the fitting of one or more units.

The router may already have some options installed in the module slots required for the MV-841/851 option. These installation instructions do not assume the presence or absence of any particular option modules already in the router.

Unpacking

A MV-841/851 Multiviewer module is supplied in dedicated packaging provided by the manufacturer and should not be accepted if delivered in inferior or unauthorized materials.



CAUTION Electrostatic Damage:
Static precautions must be observed when handling, inserting or removing modules.

- 1 Carefully unpack the system components and check them against the listed items here:
 - MV-841/851 Multiviewer main module.
 - MV-841/851 Multiviewer rear module.
- 2 Check that the equipment has not been damaged in transit. If there is anything incorrect, then notify your Grass Valley Partner, or Grass Valley, at once.
- 3 Always retain the original packing materials if possible, they could prove useful should it ever be necessary to transport or ship the equipment.

Always read the installation guide and the user instructions carefully, it will provide you with helpful hints and tips about care and maintenance and help you get the most out of your MV-841/851 Multiviewer.

(Grass Valley manuals may be downloaded from <http://www.grassvalley.com/products/>)

Hardware Installation Steps

MV-841/851 hardware installation comprises the following steps:

1. [Initial Checks and Actions](#), on page 32.
2. [Identifying Modules and Slots in Router](#), on page 35.
3. [Prepare all required modules, rear panels and other components.](#), on page 43.
4. [Removal and then Fitting of Modules](#), on page 43.
5. [Fitting Preliminaries](#), on page 46.
6. [Connecting Cables](#), on page 50.

The following sub-sections describe these installation steps.

The Sirius 800 router controller software version installed on the router must support the MV-841/851 Multiviewer.

Upgrading the Sirius 800 router controller software, if required, can be carried out either before or after the MV-841/851 hardware installation.

Initial Checks and Actions

Router Model Check

One or more MV-841 or MV-851 modules may be fitted into a Sirius 840 or Sirius 850 router.

IMPORTANT
MV-841/851 Multiviewer modules must NOT be fitted into a Sirius 830 router.

Router Frame Check

The MV-841/851 Multiviewer modules must only be fitted into a Mark 3 type Sirius router frame. This router frame type has a *blue fan rack*. (See Sirius User Manual, section 3.12.1, Table 5.)

IMPORTANT
Only fit MV-841/851 Multiviewer modules into a Sirius 840/850 **Mark 3** router frame.

Power Checks

Your Sirius 800 router may already have enough power supply capacity to power the additional MV-841/851 module(s).

However, there are many different Sirius 800 system module combinations. Therefore, before adding any MV-841/851's to a Sirius 800 router, check that the configuration of power supplies and modules fitted to your router can supply sufficient power to the MV-841/851 Multiviewer(s):

A router's available power supply capacity depends on:

- Complement of modules fitted to the router.
- Power Supply Modules fitted to the router.
- Whether the MV-841/851 replaces any currently-fitted modules and their module type.

CAUTION Power supply considerations:

The Sirius router must have enough power supply capacity to power any MV-841/851 modules being fitted.

Check that the configuration of power supplies fitted to your router can supply sufficient power to the MV-841/851 Multiviewer:

- See Sirius 800 User Manual for router power requirements.
- See [Physical/Electrical](#), on page 53 for MV-841/851 power requirements.
- Contact Grass Valley support for advice.

Router Configuration

The MV-841/851 Multiviewer performs the function of two router output modules. The host router's configuration must be set up for a MV-841/851 Multiviewer with two output slots of module type: "Digital Output Video Variant 2"

Fitting of Video SFPs to MV-841/851 Rear Panel

Before fitting the MV-841/851 Rear Panel into the router frame, first fit any SFP video modules, if this has not already been done.

This sub-section provides SFP video module fitting guidelines.



Figure 15 Coax and fiber SFP video modules

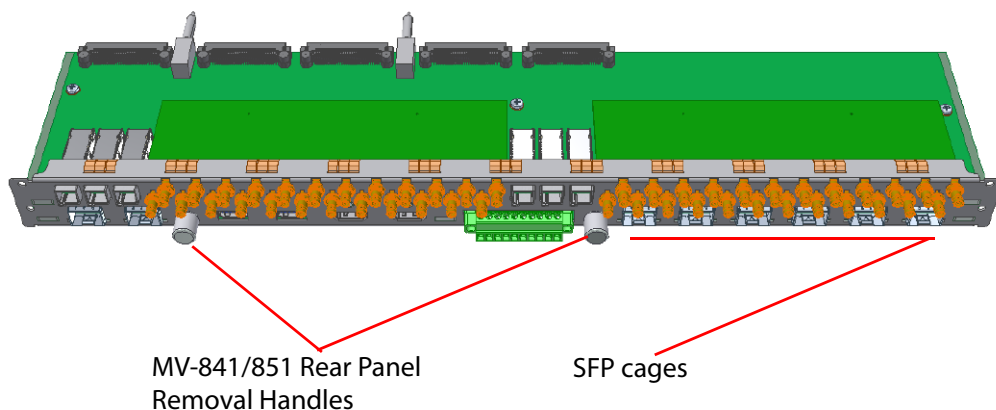

Figure 16 MV-841/851 Rear Panel, showing a horizontal orientation

The normal orientation of the MV-841/851 Rear Panel in the router is vertical. When fitting SFP modules before fitting the MV-841/851 into the router, orient the MV-841/851 module horizontally, see Figure 16, to fit any SFP modules.

Before inserting the SFP modules, take notice of the required SFP orientation for fitting into the SFP cages of the MV-841/851 Rear Panel, as shown in Figure 17.

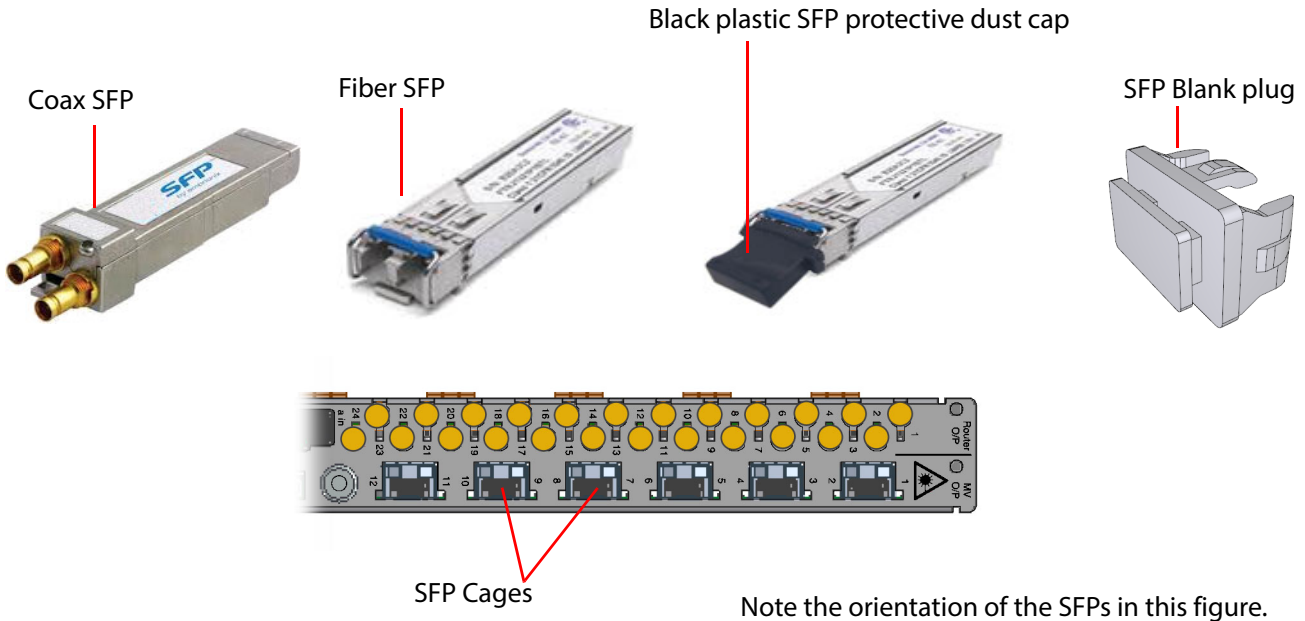

Figure 17 SFP orientation for fitting into MV-841/851 Rear Panel SFP cages

Insert the SFP video modules into the SFP cages on the MV-841/851 Rear Panel. The modules slide in until there is an audible click.

Start by filling the SFP cage for output pair 1 & 2, then 3 & 4 etc. see Figure 18. Fill any remaining slots with SFP blanking plugs (SFP-BLANK).

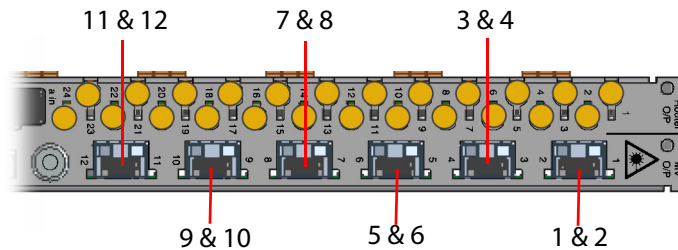

Figure 18 MV-841/851 outputs 1 to 12

SFP module removal, if required, is achieved by operating a small lever or lever-bar on the SFP module before sliding the SFP video module out of its cage.

Identifying Modules and Slots in Router

This sub-section locates the slots in a Sirius 840 or 850 router frame for the MV-841/851 Multiviewer and identifies the module types required. Slots must be located precisely in the router frame to ensure correct and swift MV-841/851 hardware installation, and to avoid the risk of disruption to the router and its operation.

To help locate the relevant slots for the MV-841/851 option, please refer to the Sirius 800 User Manual ("Module Location" section) and also to the figures in this section.

Locating slots:

Step 1. Locate the relevant section of the router frame.

Table 11 states which section of the router frame (both front and rear) to look at. This is shown in Figure 19.

Table 11 Section of Router Frame for MV-841/851 installation

Router	Section of router frame	Comment
Sirius 830	N/A	MV-841/851 is not compatible with Sirius 830.
Sirius 840	Lower section of vertical Output Module slots	See Figure 19
Sirius 850	Lower section of vertical Output Module slots	See Figure 19

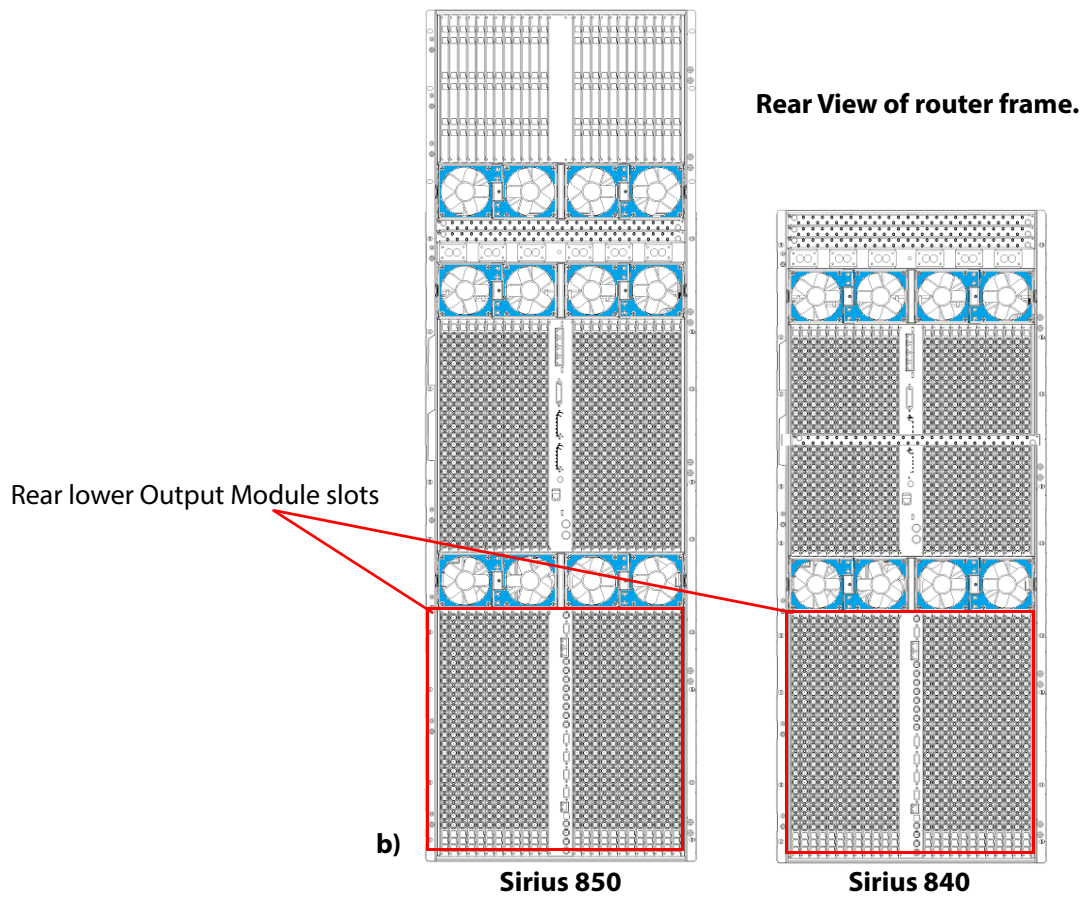
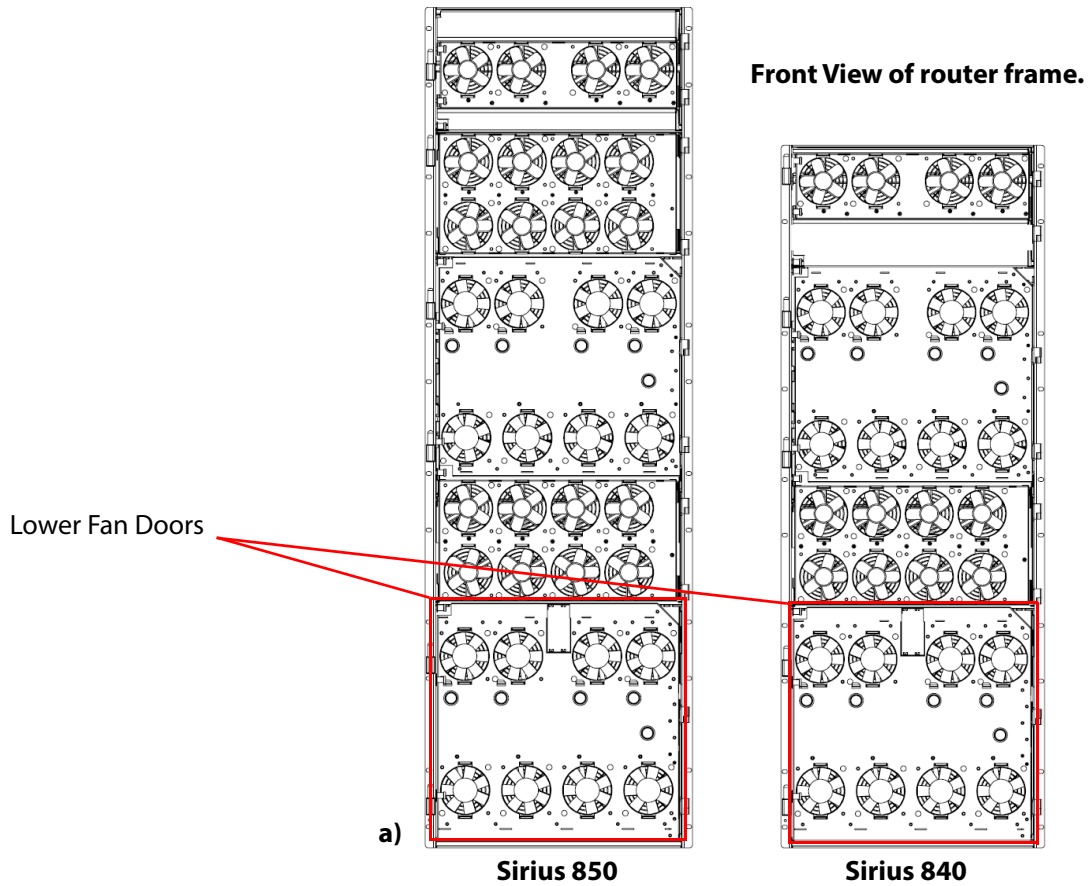

Figure 19 Sirius 800: Lower section of Sirius 840 and Sirius 850 router frame for MV-841/851 installation: a) Front Lower Fan Doors; and b) Rear Panel section.

Step 2. Locate and identify the relevant output module slots for the MV-841/851 Multiviewer.

Figure 20 and Figure 21 indicate module slots for Sirius 840 and 850 respectively. These figures show skeletal drawings of router modules, internal cards and rear panels.

Slot positions in Sirius 840 and Sirius 850 router frames are similar and Figure 22 shows module slot numbering, front and rear views.

The MV-841/851 module is a double-width module, occupying a pair of front and corresponding rear slots.

The MV-841/851 can occupy any pair of adjacent output module slots in the router.

IMPORTANT

Do not disturb any of the router's other modules, otherwise router operation may be affected.

IMPORTANT

Only open router fan doors for less than 2 minutes and ensure they are fully closed afterwards. This ensures continued cooling of the router.

Note: The MV-841/851 is a double-width module, occupying a pair of front and corresponding rear slots.

Note: The MV-841/851 can occupy any pair of adjacent output module slots in the router.

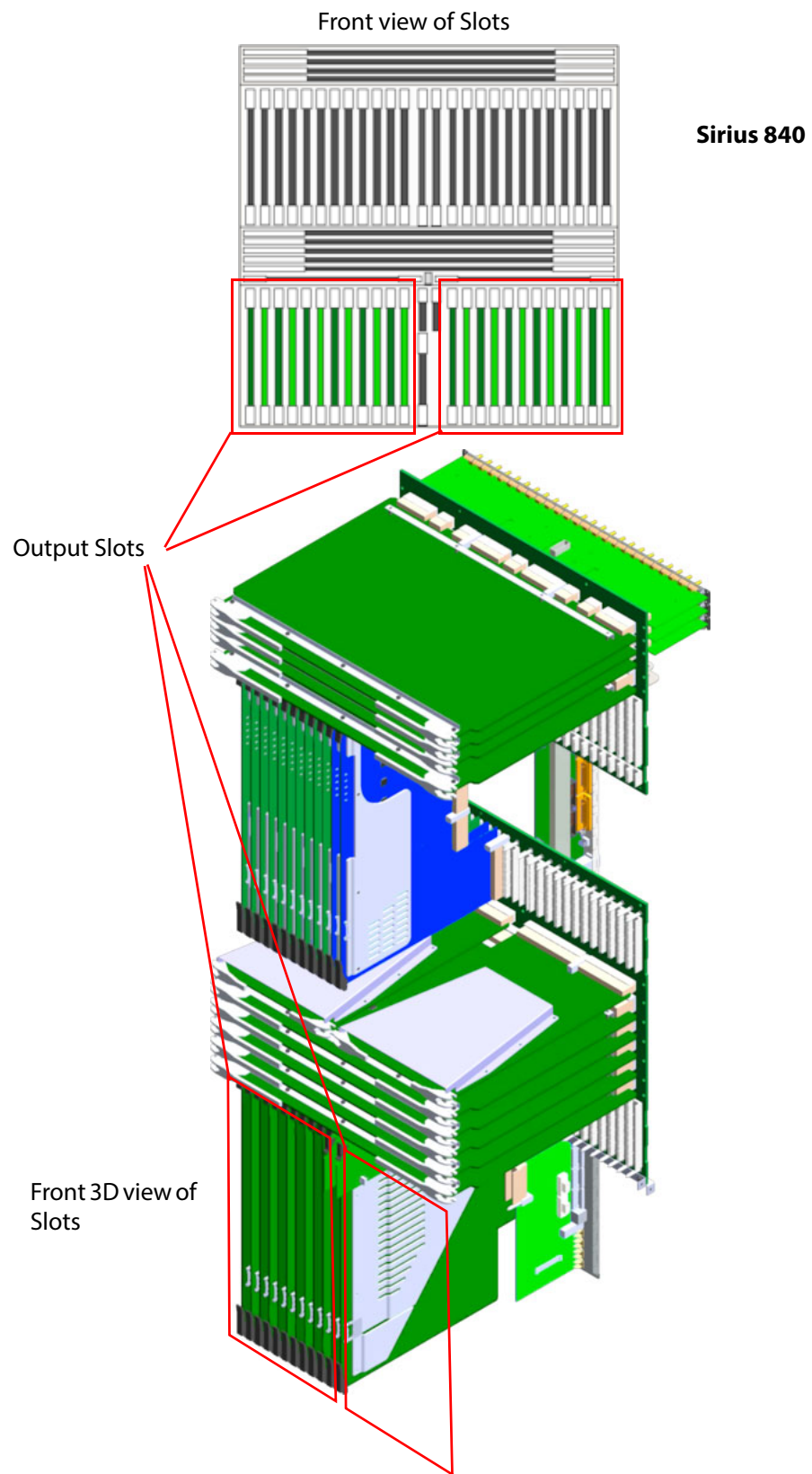

Figure 20 Sirius 840 - Relevant Module Slot Positions for MV-841/851 module(s)

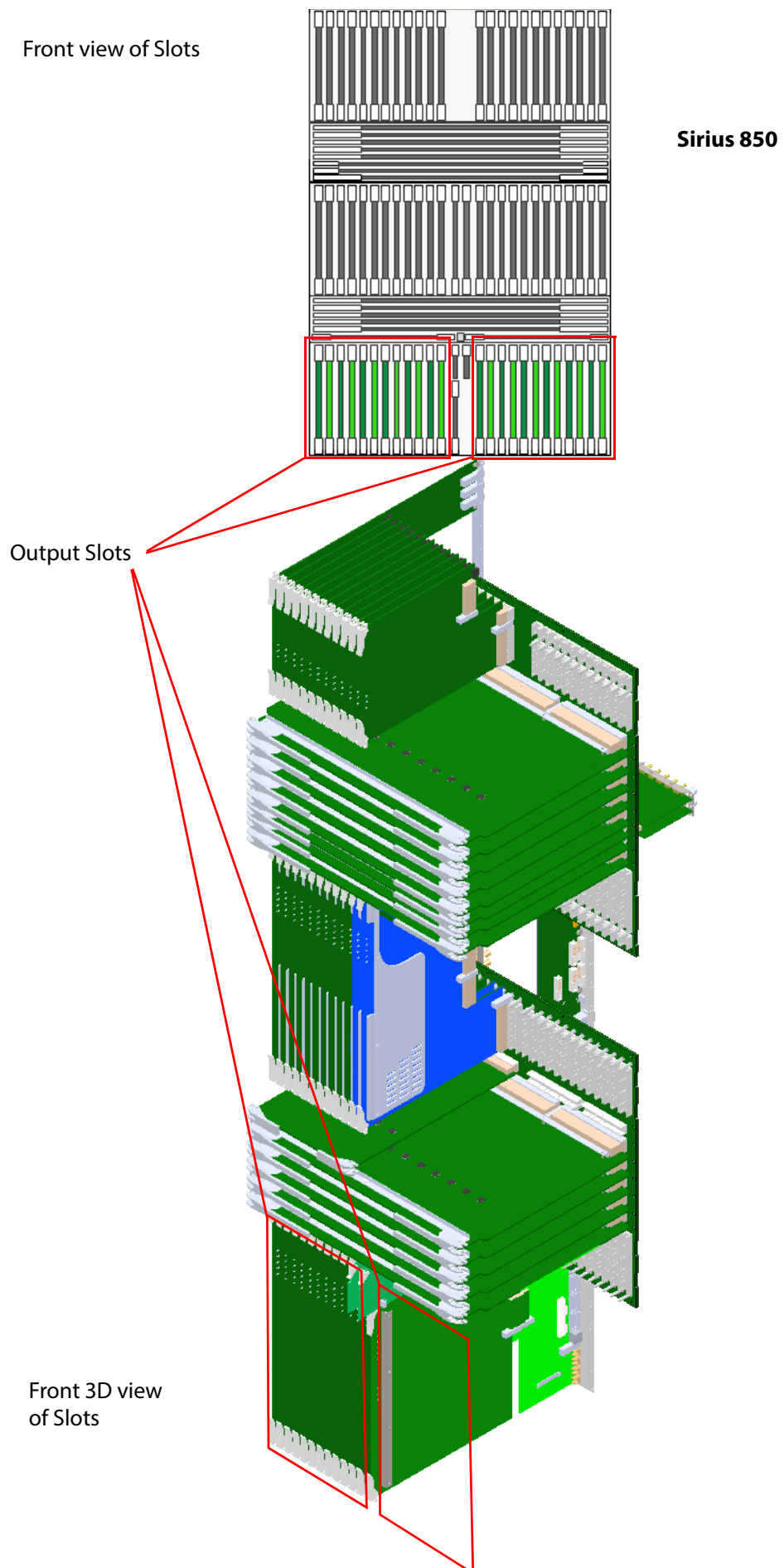

Figure 21 Sirius 850 - Relevant Module Slot Positions for MV-841/851 module(s)

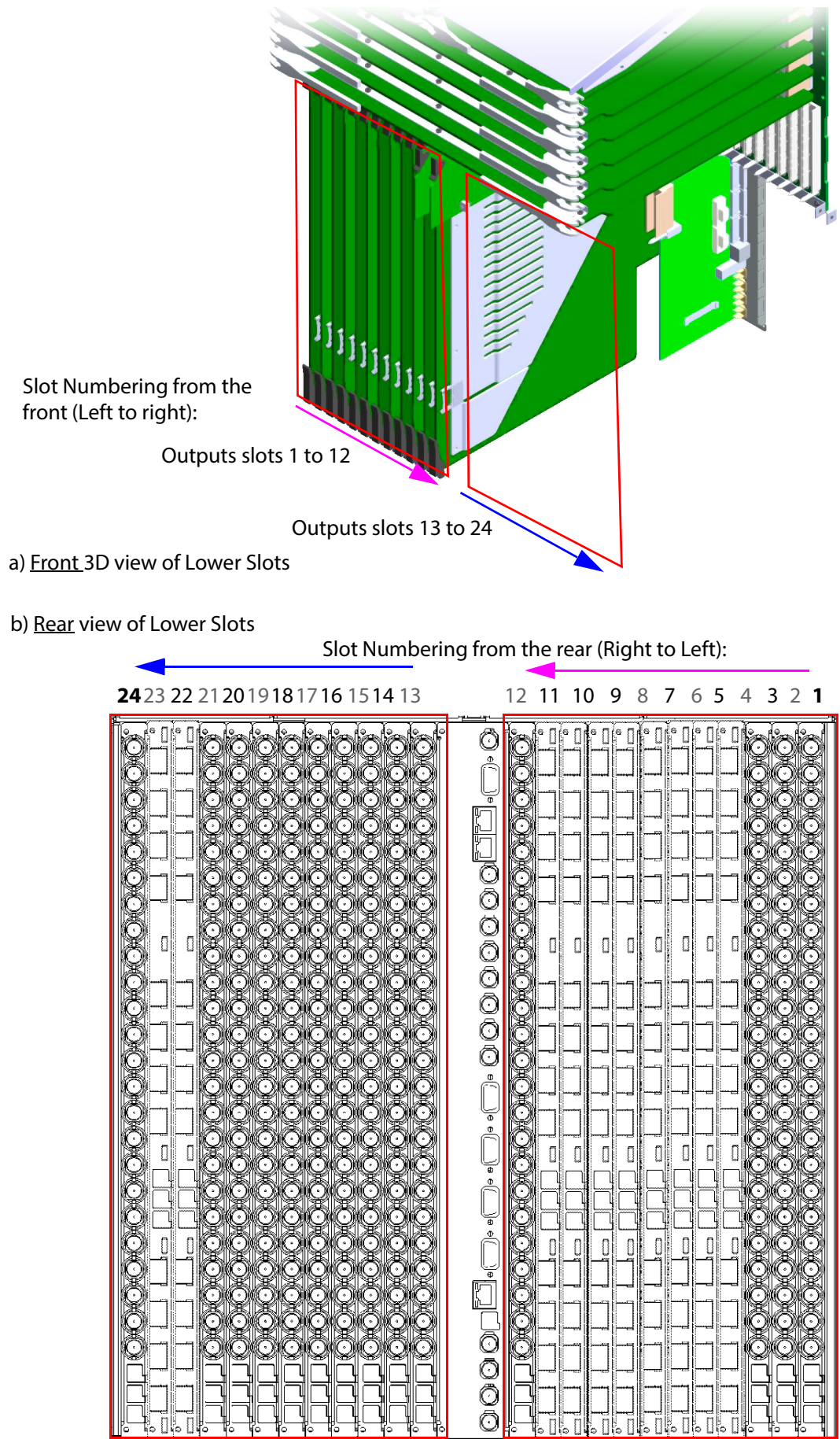

Figure 22 Sirius 840/850 Module Slot Positions for MV-841/851 module(s), a) Front View, and b) Rear View.

Step 3. For the Sirius router output modules *already* currently fitted to your router, record the module type and slot location in the “Current Modules” columns of [Table 12](#).

Table 12 records the locations of output modules and may be used as a reference when at the front or at the rear of the Sirius router frame.

Note: A MV-841/851 occupies a pair of adjacent output module slots in either Sirius 840 or Sirius 850 routers.

Step 4. Record the slot pairs (Front and Rear) to be used for MV-841/851(s) in [Table 12](#) on page 42. An MV-841/851 module may occupy any pair of adjacent output slots.

Note: When completed, [Table 12](#) will indicate;

- Location and type of modules which need to be removed before MV-841/851 installation.
- Location for insertion of MV-841/851 modules.

[Table 12](#) can be used as a reference sheet for the front and rear of the Sirius router frame.

Table 12 Slot Location Record Sheet - Sirius 840/850 Router Output Modules

Slot Location Record Sheet - Sirius Router Output Modules

	Front Modules				Rear Modules			
	SLOT	Fitted Modules	MV-841/851 Slot Pair(s)	SLOT	MV-841/851 Slot Pair(s)	Fitted Modules	SLOT	
1	1			1			1	1
2	2			2			2	2
3	3			3			3	3
4	4			4			4	4
5	5			5			5	5
6	6			6			6	6
7	7			7			7	7
8	8			8			8	8
9	9			9			9	9
10	10			10			10	10
11	11			11			11	11
12	12			12			12	12
13	13			13			13	13
14	14			14			14	14
15	15			15			15	15
16	16			16			16	16
17	17			17			17	17
18	18			18			18	18
19	19			19			19	19
20	20			20			20	20
21	21			21			21	21
22	22			22			22	22
23	23			23			23	23
24	24			24			24	24
	SLOT	Fitted Modules	MV-841/851 Slot Pair(s)	SLOT	MV-841/851 Slot Pair(s)	Fitted Modules	SLOT	
	Front Modules			Rear Modules				

FRONT VIEW

REAR VIEW

Removal and then Fitting of Modules

This section covers the removal of any existing modules from relevant slots in the router frame and then the fitting of a MV-841/851 module.

Modules may be fitted while the router is powered up.

Removal Preliminaries

Some warnings and points of note are provided below: The following removal and fitting procedures are designed to comply with these points.

Prepare all required modules, rear panels and other components.

Note: A MV-841/851 comprises a front module and a rear panel.
Thus MV-841/851 occupies the following Sirius 840/850 router slots:

- A pair of front output module slots.
 - A pair of corresponding rear output slots.
-

Before fitting a MV-841/851 module, the relevant front and rear module slots need to be emptied first before fitting the MV-841/851 option hardware.

CAUTION

Ensure both of the front *and corresponding* rear slots in the router frame are *first empty* before inserting the MV-841/851 Main Module and/or MV-841/851 Rear Panel.

This is because:

- MV-841/851 front Main Modules must not be accidentally connected to any other rear panels already fitted in the router frame.
 - MV-841/851 Rear Panels must not be accidentally connected to any other front modules already fitted in the front of the router frame.
-

IMPORTANT

Fit the MV-841/851 Rear Panel(s) before fitting the front MV-841/851 Main Module(s).

These instructions are deliberately written in two stages:

1. Removal. (See [Module\(s\) Removal Procedure](#) on page 44)
2. *Then* fitting. (See [Fitting Preliminaries](#) on page 46)

This avoids any interim incompatibility between different front and rear modules during fitting, which may damage modules and the router.

Note: The fan door assemblies should be returned to the closed position as soon as possible after opening. This ensures correct ventilation and operation of the router frame.

In practice:

- Maximum time that a fan door may be left open will depend on a number of factors, such as: ambient temperature, router frame loading, crosspoint routing, etc.
- To ensure correct operation under all conditions, the fan assemblies should be left open for no more than 2 minutes at a time.
- Avoid repeated opening of fan doors. Leave a fan door closed for at least 5 minutes after it has been open for 2 minutes; this restores correct ventilation.
- Take care not to trap any cables when opening and closing the fan doors.

To minimize the time that router frame doors and fan doors are open, ensure that you understand which modules need to be changed and where they are located: Refer to your completed [Table 12](#) on [page 42](#).

Read through the following installation steps and notes to ensure that you understand them before installing an MV-841/851.

Module(s) Removal Procedure



CAUTION **Electrostatic Damage**

Static precautions must be observed when handling, inserting or removing modules.

Note: Rear module removal requires:

- A Pozidriv screwdriver suitable for pan head, M3 x 6 mm, zinc plated screws.
-

Removal Procedure for Rear then Front Modules

1. Start at the rear of the router.

The first step is to empty *relevant* slots of front modules or rear panels, ready for the MV-841/851 modules:

2. Locate the pair(s) of rear modules to remove.
[Table 12](#) on [page 42](#) indicates which modules need to be removed.
3. Disconnect all cables connected to rear panel connectors on rear slots that need to be emptied.

Rear module removal:

4. Remove all rear modules for slots that need to be emptied. Unscrew rear panel securing screws on each module (two or four screws, depending on the module being removed) and then remove the module.

Note: An MV-841/851 rear panel has handles to assist removal (see [Figure 16](#) on page 33).

IMPORTANT When removing any module:

Take care not to knock high components mounted on the top- or on the bottom-side of the module or any surrounding modules. Because any knock may damage the module being removed, or the surrounding modules in the router frame.

The relevant rear slots are now emptied.

5. Now move to the front of the router.
6. Unlock and open the router front door and open the relevant internal fan door (refer to [Figure 19](#) on page 36).

Front module removal:

7. Locate the pair(s) of front modules to remove. Refer to [Table 12](#) on page 42.
8. Remove all front modules from front slots that need to be emptied by pulling on the two module eject levers and sliding the module out of the frame. See [Figure 23](#).

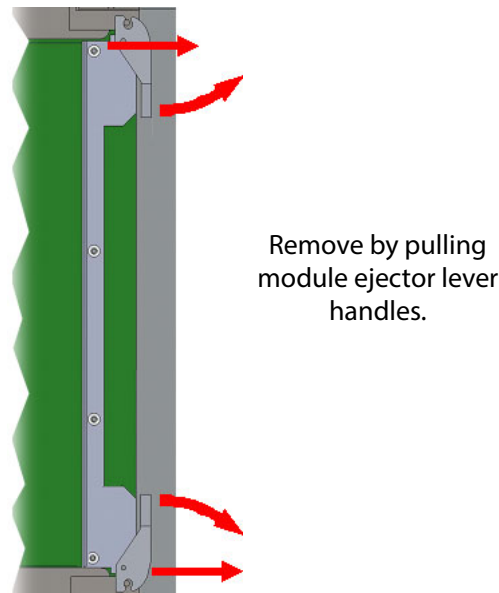

Figure 23 Removing Front Modules, showing use of module eject levers

9. Close and secure the internal fan door. Close and lock the router front door.

All relevant slots should now be empty, both front and rear, ready for fitting one or more MV-841/851 modules.

10. Continue immediately to read Section [“Fitting Preliminaries”](#) on page 46 before starting Section [“Module Fitting Procedure”](#) on page 47.

Fitting Preliminaries



Electrostatic Damage

Static precautions must be observed when handling, inserting or removing modules.

Note: Rear module fitting requires:

- A Pozidriv screwdriver
- Two pan head, M3 x 6 mm, zinc plated screws per rear module.

IMPORTANT When inserting a module:

Take care not to knock high components which are mounted on the top- or on the under-side of the module. Any knocks may damage the module being inserted, or the modules above and below it in the router frame.

Note: When inserting a *rear* module into a rear slot:

- Check the module is the correct one for the slot.
 - Check there are no obstructions at the module connectors.
 - Check for any high components on the top- or under-side of the module. Do not knock these during fitting.
 - Insert the module into the slot and slide the module into the frame.
 - In the last few millimeters of travel, the module connectors mate with the router motherboard. Some resistance will be met; ease, but do not force, the module in.
 - If excessive resistance is met, remove the module and re-check that the module and slot are correct. Check the slot for any obstruction. Check the module connectors for any damage or foreign objects.
 - Fasten the two module securing screws at the far left and far right of the module's rear plate. Gently tighten the fixing screws. Do not over-tighten them.
-

Note: When inserting a *front* module into a front slot:

- Check the module is the correct one for the slot.
 - Check there are no obstructions at the module connectors.
 - Check for any high components on the module's top- or under-side. Do not knock these during fitting.
 - Insert the module into the slot and slide the module into the frame.
 - When the module is nearly fully in the frame, gently push the module levers. See Figure 26
 - In the last few millimeters of travel, the module connectors mate with the internal router motherboard and its rear panel module.
Some resistance will be met; ease, but do not force, the module in with the levers.
 - If excessive resistance is met, remove the module and re-check that the module and slot are correct. Check the slot for any obstruction. Check the module connectors for any damage or foreign objects.
 - In the final few millimeters of travel, the levers engage with the router frame, locking the module into position
-

Refer to [Table 12](#) on page 42 for MV-841/851 module fitting slot locations.

Module Fitting Procedure

Please ensure that you have read [Fitting Preliminaries](#), on page 46 before proceeding to fit modules.

1. Go to the **rear of the router frame**.

The procedure begins with the fitting of rear modules:

2. Locate the rear slot pairs for **MV-841/851** fitting.
Refer to [Table 12](#) on page 42 for MV-841/851 module fitting locations.
3. Insert an MV-841/851 Rear Panel module into the rear slot pair.
Repeat for each further rear panel module being fitted.
Check the orientation of the rear module, see Figure 24.

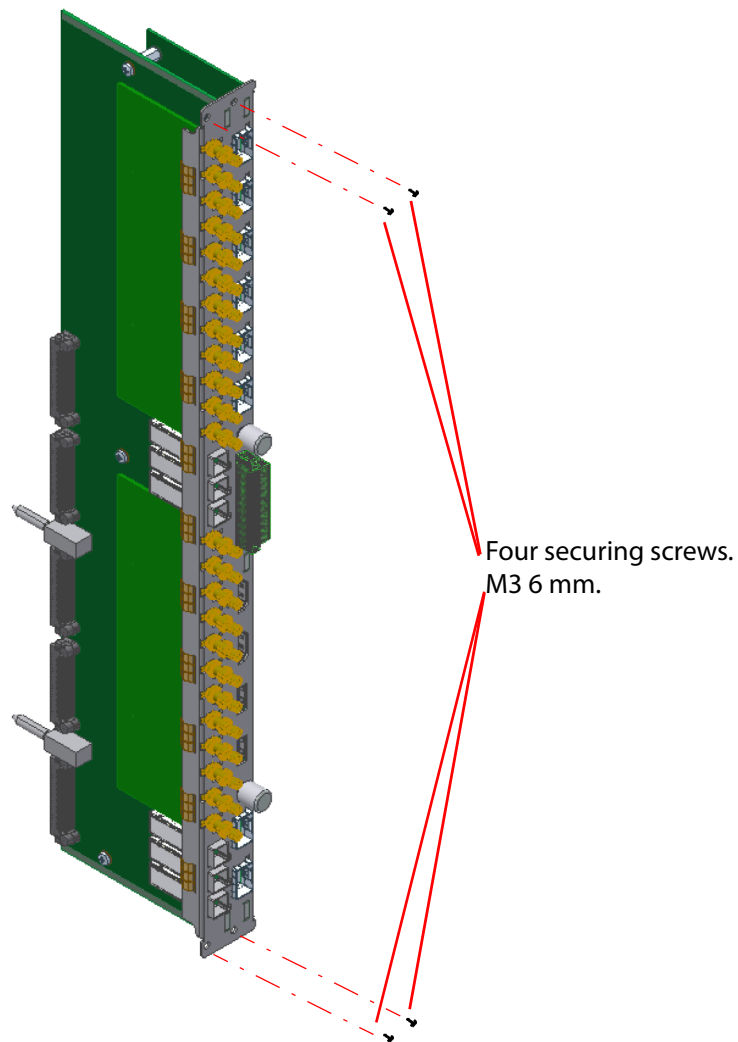

Figure 24 'MV-841/851-RP' Rear Panel module

4. Fasten the MV-841/851 rear panel module in position with four securing screws, see Figure 24.
Do not over-tighten the screws.

Note: Do not over-tighten the rear panel fastening screws.

- They should screw in without any resistance until the screw head secures the rear panel to the frame.
- If a rear panel fastening screw binds up then it should be removed and the screw and its alignment should be checked before the screw is refitted.

5. Fit blanking plates (Figure 25) to any remaining empty rear slots. Fasten the two plate-securing screws. Gently tighten the fixing screws. Do not over-tighten them.

Note: The risk of non-compliance and overheating is with the user if blanking plates are not fitted in unused rear slots.



Figure 25 Rear Blanking Panel - for empty rear slots

Rear modules are now fitted.

6. Now go to the **front of the router**.
7. Locate the front slot pairs for MV-841/851 fitting.
Refer to [Table 12](#) on page 42 for MV-841/851 module fitting locations.
8. Insert a MV-841/851 Front Module into each front slot pair.

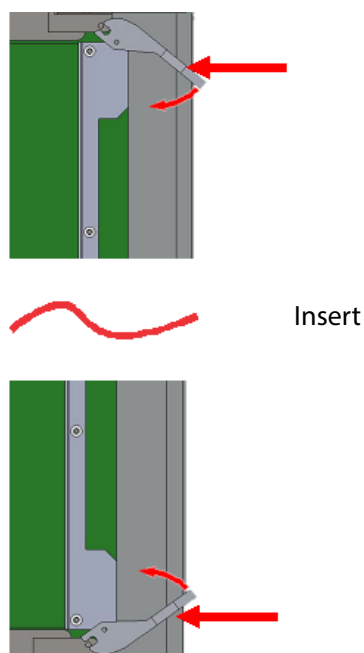

Figure 26 Inserting a Front Module with Levers

9. Close and secure the front fan door assembly, making sure not to trap any wires.
10. Close and lock the router front door.

The MV-841/851 Multiviewer hardware is now fitted in the router frame.

Connecting Cables

Now that the MV-841/851 Multiviewer hardware is fitted, some cable connections need to be made. Figure 27 shows the connections that need to be made.

Note: The MV-841/851 must initially be configured from a computer before being attached to the router's ultimate IT network.
See Section 7 "[RollCall Configuration](#)" on page 66

1. Connect the MV-841/851 directly to a computer network port via 1G Ethernet port 1 (see Figure 27) using a standard CAT 5e Ethernet cable.
2. Connect up to 4 display monitor screens to Multiviewer **Head Display Outputs** 1 to 4. If more Multiviewer Display Outputs have been licensed, then connect these.
3. Connect **SDI Video Outputs** to downstream video equipment inputs.
4. If the host router is part of a S850 Expansion configuration, connect the **Expansion Video Inputs**.
5. Connect any GPIO and LTC connections.

For a full list of MV-841/851 input and output connectors and pinouts, see Section "[MV-841/851 Multiviewer Rear Panel \(MV-840-RP/MV-850-RP\)](#)" on page 20.

See the '[MV-8 Series Multiviewer](#)' user manual for details on configuring the MV-841/851.

IMPORTANT Ethernet connection:

Check the *logical* and *physical* connection of all Ethernet ports to the MV-841/851 rear panel.
This is required for optimum MV-841/851 performance.

Explanation:

The MV-841/851 has more than one Ethernet port with one IP address per Ethernet port.

However, even if a port is disconnected, its IP address can still be "seen" through other the Ethernet ports.

This means the MV-841/851 can still *appear* to be operating normally, i.e. with all Ethernet ports connected, even with one or more unconnected network ports.

There is a MV-841/851 performance penalty for operating in this way.

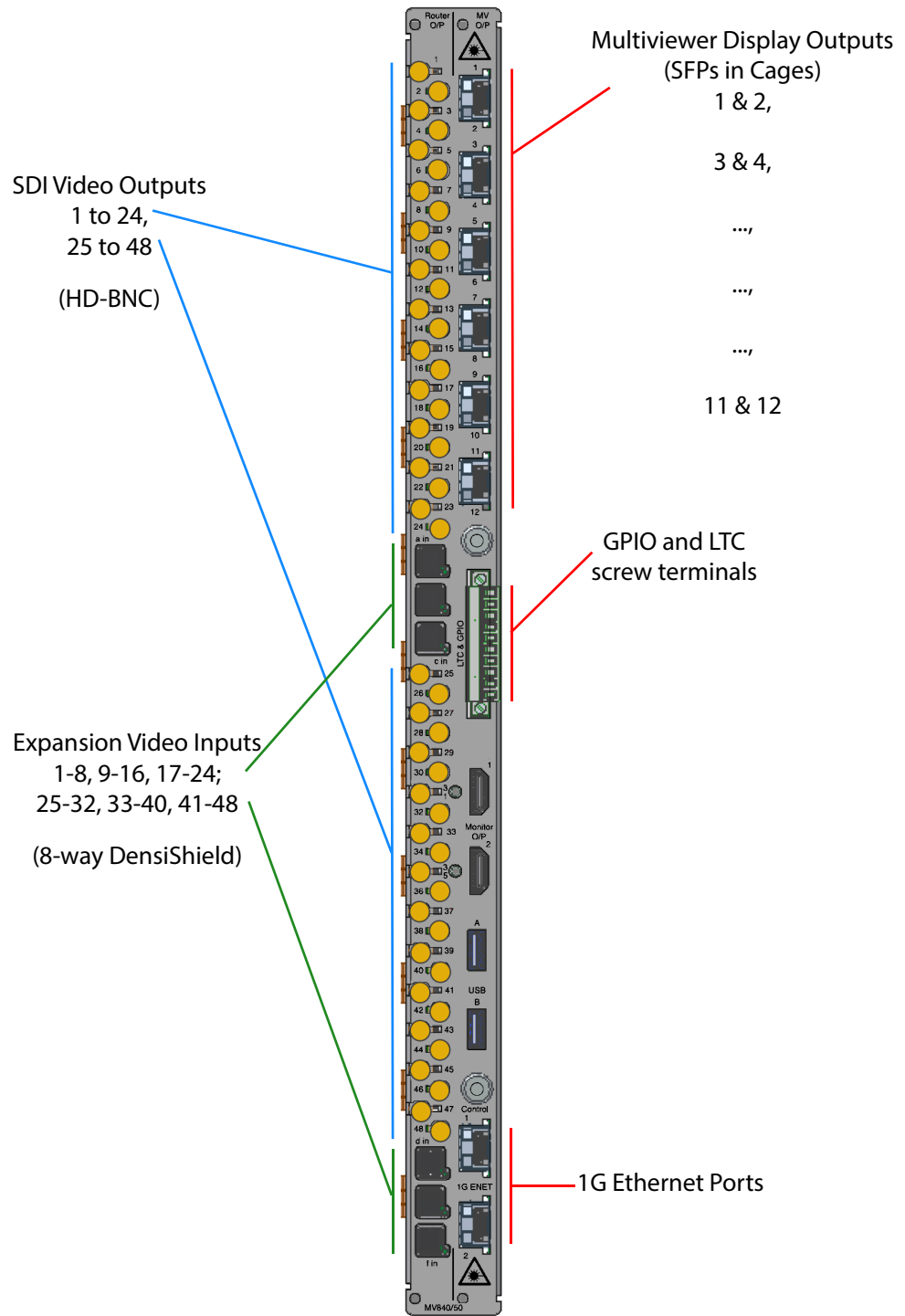

Figure 27 MV-841/851 Multiviewer Rear Panel Connections

MV-841/851 Module Booting

Refer to the '*MV-8 Series Multiviewer*' user manual for information about MV-841/851 module booting and start-up splash screen.

Note: Use the '1G1' network interface when performing the initial unit configuration with Grass Valley RollCall control panel.

Note: The 'Eng' interface is a reserved internal IP network interface, do not use this interface.

A Specification

Physical/Electrical

Power	
Power consumption	250 W
Environmental	
Operating Temperature	5°C to 30 °C ambient. See Note 1 .
Relative Humidity	10 to 90% (non-condensing)
Weight	
Front Module	3.5 kg (7.7 lb)
Rear Panel	1 kg (2.2 lb)
<p>Note 1: The MV-841/851 operating temperature range is lower than that of the Sirius 840 or 850 host router.</p> <p>Refer to the Sirius 800 User Manual for the router frame operating temperature range.</p>	

Dimensions

Front Module (MV-841-MB/MV-851-MB)

Dimensions	
Width	435 mm (~ 17.25 in.) approx.
Depth	345 mm (~ 13.6 in.) approx.
Height	32 mm (~ 1.3 in.) approx.

Rear Panel (MV-840-RB/MV-850-RB)

Dimensions	
Width	435 mm (~ 17.25 in.) approx.
Depth	135 mm (~ 5.6 in.) approx.
Height	32 mm (~ 1.3 in.) approx.

Inputs

Signal	
Router Expansion Video Inputs	6 off DS-Link. with 8-off SD-SDI/ HD-SDI/ 3G-SDI per DS-Link.
Reference	Reference timing is obtained internally from the host router.
<p>Note 1: ASI and MV-841/851 Integrated Multiviewer: The Sirius 840/850 routers can switch ASI signals and the router inputs and router outputs of the MV-841/851 module pass ASI signals. However, the <i>MV-8 Series Multiviewer</i> on the MV-841/851 module only handles baseband video signals, i.e. SD/HD/3G signals and <i>not</i> ASI. If an ASI signal is fed to the <i>MV-8 Series Multiviewer</i> on the MV-841/851 module, it will report signal loss.</p>	

Outputs

Router Outputs	
Video Outputs	24-off HD-BNC 75R Coax, re-clocked
Standards supported	SMPTE-259M 525 and 625 SD-SDI EN50083-9 DVB-ASI (See Note 1 and Note 2) SMPTE 292M 720p and 1080i HD-SDI SMPTE 424M 1080p 3G-SDI
Data rate	3 Mb/s to 3 Gb/s. Standard video rates re-clocked, all other rates auto-bypassed.
Return Loss	>15 dB, 10 MHz to 1.5 GHz >10 dB, 1.5 GHz to 3 GHz
Amplitude	800 mV p-p \pm 10%
Rise/Fall time	<90 ps @ 3G <180 ps @ HD <650 ps @ SD
Timing Jitter	<0.25 UI @ 1.5G and 3G <0.15 UI @ SD
Alignment Jitter	<0.15 UI @ 1.5G and 3G <0.1 UI @ SD
DC offset	0 V \pm 0.5 V
<p>Note 1: ASI and a Sirius Router: The Sirius 840/850 router can switch ASI signals and the router outputs of an MV-841/851 module can pass ASI signals. The presence of ASI on these signals is reported to the router controller. The MV-841/851 Integrated Multiviewer fully supports this ASI router functionality.</p>	

Router Outputs	
	<p>Note 2: ASI and MV-841/851 Multiviewer Block: However, the monitoring 'Multiviewer block' on an MV-841/851 module only supports baseband video signals, i.e. SD/HD/3G signals, and <i>not</i> ASI. If an ASI signal is fed to the 'MV Block', then the MV-841/851 will report a signal loss at the 'MV block'.</p>
Multiviewer Outputs	
Head Display Outputs	<p>From 4 up to 12 SDI video outputs. HD-BNC Coax or Fiber.</p> <ul style="list-style-type: none"> • Outputs 1 to 4 on standard MV-841/851. • Outputs 5 to 12, with MV-841/851 licenses.
Video Standard	<p>Video Standard on 75 ohm coax display outputs:</p> <ul style="list-style-type: none"> • 3G 1080p. • HD 720p. <p>At 50, 59.94 or 60 frames/s.</p>
Reference Lock	<p>One reference for all outputs. Display Outputs locked according to multiviewer reference setting to one of:</p> <ul style="list-style-type: none"> • Host Router Reference. • Internal Reference (free running).
Delay latency	<p>Progressive input: 1 input frame + 1 to 3 output frames. Interfaced input: 1 input field + 1 to 3 output frames.</p>
Optional SFPs	<p>Optional SFPs:</p> <ul style="list-style-type: none"> • Dual coax SFP. • Dual Fiber SFP. • Single HDMI SFPs. (Up to 6 x HDMI outputs, 1080p or 720p)
Streaming Out of 'MV-Input-Copies'	
Output Streams - Streaming MV Inputs:	<p>Up to 48-off Streamed outputs - scaled and H.264 encoded copies of the multiviewer block inputs</p> <p>Each multiviewer block input is H264 encoded to create streamed copies of the 48 inputs. These are streamed out over IP.</p> <p>The streams can be viewed on desktop PCs via the Grass Valley GV Orbit Lite software.</p> <p>Note: The H.264 streams do not function for the following slower-frame-rate HD standards:</p> <ul style="list-style-type: none"> • 1080p30 (and slower frame rates); and • 720p30 (and slower frame rates). <p>Applications include: confidence monitoring, compliance monitoring.</p>

TV Standards

Video Standard			
3G-SDI: 2.97Gbps	1080p	59.94 Hz	SMPTE 424M/Level A (router outputs and multiviewer)
			SMPTE 424M/Level B (router outputs only)
	1080p	60 Hz	SMPTE 424M/Level A (router outputs and multiviewer)
			SMPTE 424M/Level B (router outputs only)
	1080p	50 Hz	SMPTE 424M/Level A (router outputs and multiviewer)
			SMPTE 424M/Level B (router outputs only)
HD-SDI: 1.485 Gbps	1080i	60 Hz	(ANSI/SMPTE-274M(4) 292M(D))
	1080i	59.94 Hz	(ANSI/SMPTE-274M(5) 292M(E))
	1080i	50 Hz	(ANSI/SMPTE-274M(6),-292M(F))
	1035i	60 Hz	(ANSI/SMPTE-260M-292M(A))
	1035i	59.94 Hz	(ANSI/SMPTE-260M,-292M(B))
	1080p	30 Hz sF	(ANSI/SMPTE-274M(12) as per RP211)
	1080p	29.97 Hz sF	(ANSI/SMPTE-274M(13) as per RP211)
	1080p	25 Hz sF	(ANSI/SMPTE-274M(14) as per RP211)
	1080p	24 Hz sF	(ANSI/SMPTE-274M(15) as per RP211)
	1080p	23.976Hz sF	(ANSI/SMPTE-274M(16) as per RP211)
	1080p	30 Hz	(ANSI/SMPTE-274M(7)-292M(G))
	1080p	29.97 Hz	(ANSI/SMPTE-274M(8)-292M(H))
	1080p	25 Hz	(ANSI/SMPTE-274M(9)-292M(I))
	1080p	24 Hz	(ANSI/SMPTE-274M(10)-292M(J))
	1080p	23.976 Hz	(ANSI/SMPTE-274M(11)-292M(K))
	720p	60 Hz	(ANSI/SMPTE-296M(1)-292M(L))
	720p	59.94 Hz	(ANSI/SMPTE-296M(2)-292M(M))
	720p	50 Hz	(ANSI/SMPTE-296M(2)-292M(M))
SD Video Standards	525	60 Hz/ 59.94 Hz 4:3/16:9	(ITU-R BT.601-5, ANSI/SMPTE-259M(2))
	625	50 Hz 4:3/16:9	(ITU-R BT.601-5, ANSI/SMPTE-259M(2))
DVB ASI			EN50083-9 DVB-ASI (router outputs only)

GPI and LTC

GPI	
Connector	10 Way Screw Terminal type connector. Programmable GPIO Tally with TTL-level/contact-closure inputs for GPI See LTC and GPIO Connector Pin-outs on page 26 for wiring details and pin-out.

Ethernet Rear Panel Connectors

Connectors	
1G Ethernet	2-off 1 Gbps SFP+ cages for Ethernet SFPs. Ethernet socket RJ45. Port 1 and 2.

Table 13 MV-841/851 Default IP Addresses, Ethernet Ports 1 to 2

Ethernet port	RollCall Control Panel MV-841/851 Template	Interface Type	Default IP Address
Port 1	1G1	1G	10.54.31.221
Port 2	1G2	1G	10.54.31.222

Unused Rear Panel Connectors

Connectors	
Monitor	2-off. Not currently used.
USB	2-off. Not currently used.

Monitoring and Alarms

For specification of the multiviewer engine and all video wall capabilities, please refer to the 'MV-8 Series Multiviewer' user manual.

Software Versions

Tool	Version
RollCall Control Panel	4.17.1 or later
Orbit Client	v3.0.10 or later
GV Orbit	v4.0.0 or later
Multiviewer	v3.2.22 or later

Note: For future releases:
Please refer to Multiviewer, GV Orbit and RollCall Control Panel etc. software release notes for compatibility information.

User Notes:

Contact Us

Grass Valley Technical Support

For details of our Regional Customer Support Offices please visit the Grass Valley web site at:

<https://www.grassvalley.com/contact/support/>

Customers with a support contract should call their personalized number, which can be found in their contract, and be ready to provide their contract number and details.

For technical assistance, contact our international support center, at 1-800-547-8949 (US and Canada) or +1 530 478 4148.

To obtain a local phone number for the support center nearest you, please consult the 'Contact Us' section of Grass Valley's website (www.grassvalley.com).

An on-line form for e-mail contact is also available from the website.

Corporate Head Office

Grass Valley

3499 Douglas-B.-Floreani

St-Laurent, Quebec H4S 2C6

Canada

Telephone:+1 514 333 1772

Fax:+1 514 333 9828

www.grassvalley.com