



grass valley

A **BELDEN** BRAND

GV K-FRAME XP

VIDEO PRODUCTION FRAMES

Installation Planning Guide

1300112000-AA

10/12/20

www.grassvalley.com

FCC Compliance

In order to comply with FCC/CFR47: Part 15 regulations, it is necessary to use high-quality triple-screened Media or Monitor cable assemblies with integrated ferrite suppression at both ends.

Patent Information

This product may be protected by one or more patents.

For further information, please visit: www.grassvalley.com/patents/

Copyright and Trademark Notice

Grass Valley[®], GV[®] and the Grass Valley logo and/or any of the Grass Valley products listed in this document are trademarks or registered trademarks of GVBB Holdings SARL, Grass Valley USA, LLC, or one of its affiliates or subsidiaries. All other intellectual property rights are owned by GVBB Holdings SARL, Grass Valley USA, LLC, or one of its affiliates or subsidiaries. All third party intellectual property rights (including logos or icons) remain the property of their respective owners.

Copyright ©2020 GVBB Holdings SARL and Grass Valley USA, LLC. All rights reserved.

Specifications are subject to change without notice.

Terms and Conditions

Please read the following terms and conditions carefully. By using GV K-Frame XP Video Production Center documentation, you agree to the following terms and conditions.

Grass Valley hereby grants permission and license to owners of to use their product manuals for their own internal business use. Manuals for Grass Valley products may not be reproduced or transmitted in any form or by any means, electronic or mechanical, including photocopying and recording, for any purpose unless specifically authorized in writing by Grass Valley.

A Grass Valley manual may have been revised to reflect changes made to the product during its manufacturing life. Thus, different versions of a manual may exist for any given product. Care should be taken to ensure that one obtains the proper manual version for a specific product serial number.

Information in this document is subject to change without notice and does not represent a commitment on the part of Grass Valley.

Warranty information is available from the Legal Terms and Conditions section of Grass Valley's website (www.grassvalley.com).

Title Installation Planning Guide

Part Number 1300112000-AA

Revision 2020-10-12

Important Safety Information

This section provides important safety guidelines for operators and service personnel. Specific warnings and cautions appear throughout the manual where they apply. Please read and follow this important information, especially those instructions related to the risk of electric shock or injury to persons.

Symbols and Their Meanings



Indicates that dangerous high voltage is present within the equipment enclosure that may be of sufficient magnitude to constitute a risk of electric shock.



Indicates that the user, operator or service technician should refer to the product manuals for important operating, maintenance, or service instructions.



This is a prompt to note the fuse rating when replacing fuses. The fuse referenced in the text must be replaced with one having the ratings indicated.



Identifies a protective grounding terminal which must be connected to earth ground prior to making any other equipment connections.



Identifies an external protective grounding terminal which may be connected to earth ground as a supplement to an internal grounding terminal.



Indicates that static sensitive components are present, which may be damaged by electrostatic discharge. Use anti-static procedures, equipment and surfaces during servicing.



Indicates that the equipment has more than one power supply cord, and that all power supply cords must be disconnected before servicing to avoid electric shock.



The presence of this symbol in or on Grass Valley equipment means that it has been tested and certified as complying with applicable Underwriters Laboratory (UL) regulations and recommendations for USA.



The presence of this symbol in or on Grass Valley equipment means that it has been tested and certified as complying with applicable Canadian Standard Association (CSA) regulations and recommendations for USA/Canada.



The presence of this symbol in or on Grass Valley equipment means that it has been tested and certified as complying with applicable Underwriters Laboratory (UL) regulations and recommendations for USA/Canada.



The presence of this symbol in or on Grass Valley equipment means that it has been tested and certified as complying with applicable Intertek Testing Services regulations and recommendations for USA/Canada.



The presence of this symbol in or on Grass Valley product means that it complies with all applicable European Union (CE) directives.



The presence of this symbol in or on Grass Valley product means that it complies with safety of laser product applicable standards.

Warnings



A warning indicates a possible hazard to personnel, which may cause injury or death. Observe the following general warnings when using or working on this equipment:

- Appropriately listed/certified mains supply power cords must be used for the connection of the equipment to the rated mains voltage.
- This product relies on the building's installation for short-circuit (over-current) protection. Ensure that a fuse or circuit breaker for the rated mains voltage is used on the phase conductors.
- Any instructions in this manual that require opening the equipment cover or enclosure are for use by qualified service personnel only.
- Do not operate the equipment in wet or damp conditions.
- This equipment is grounded through the grounding conductor of the power cords. To avoid electrical shock, plug the power cords into a properly wired receptacle before connecting the equipment inputs or outputs.
- Route power cords and other cables so they are not likely to be damaged. Properly support heavy cable bundles to avoid connector damage.
- Disconnect power before cleaning the equipment. Do not use liquid or aerosol cleaners; use only a damp cloth.
- Dangerous voltages may exist at several points in this equipment. To avoid injury, do not touch exposed connections and components while power is on.
- High leakage current may be present. Earth connection of product is essential before connecting power.
- Prior to servicing, remove jewelry such as rings, watches, and other metallic objects.
- To avoid fire hazard, use only the fuse type and rating specified in the service instructions for this product, or on the equipment.

- To avoid explosion, do not operate this equipment in an explosive atmosphere.
- Use proper lift points. Do not use door latches to lift or move equipment.
- Avoid mechanical hazards. Allow all rotating devices to come to a stop before servicing.
- Have qualified service personnel perform safety checks after any service.

Cautions



A caution indicates a possible hazard to equipment that could result in equipment damage. Observe the following cautions when operating or working on this equipment:

- This equipment is meant to be installed in a restricted access location.

Note: Limited access restrictions apply to Video Processor Frames and Servers, not to operator controlled equipment such as Control Panels, Menus, Aux Panels, etc.

- When installing this equipment, do not attach the power cord to building surfaces.
- Products that have no on/off switch, and use an external power supply must be installed in proximity to a main power outlet that is easily accessible.
- Use the correct voltage setting. If this product lacks auto-ranging power supplies, before applying power ensure that each power supply is set to match the power source.
- Provide proper ventilation. To prevent product overheating, provide equipment ventilation in accordance with the installation instructions.
- Do not operate with suspected equipment failure. If you suspect product damage or equipment failure, have the equipment inspected by qualified service personnel.
- To reduce the risk of electric shock, do not perform any servicing other than that contained in the operating instructions unless you are qualified to do so. Refer all servicing to qualified service personnel.
- This unit may have more than one power supply cord. Disconnect all power supply cords before servicing to avoid electric shock.
- Follow static precautions at all times when handling this equipment. Servicing should be done in a static-free environment.
- To reduce the risk of electric shock, plug each power supply cord into separate branch circuits employing separate service grounds.

Electrostatic Discharge (ESD) Protection



Electrostatic discharge occurs when electronic components are improperly handled and can result in intermittent failure or complete damage adversely affecting an electrical circuit. When you remove and replace any card from a frame always follow ESD-prevention procedures:

- Ensure that the frame is electrically connected to earth ground through the power cord or any other means if available.
- Wear an ESD wrist strap ensuring that it makes good skin contact. Connect the grounding clip to an *unpainted surface* of the chassis frame to safely ground unwanted

ESD voltages. If no wrist strap is available, ground yourself by touching the *unpainted* metal part of the chassis.

- For safety, periodically check the resistance value of the antistatic strap, which should be between 1 and 10 megohms.
- When temporarily storing a card make sure it is placed in an ESD bag.
- Cards in an earth grounded metal frame or casing do not require any special ESD protection.

Battery Handling



This product may include a backup battery. There is a danger of explosion if the battery is replaced incorrectly. Replace the battery only with the same or equivalent type recommended by the manufacturer. Dispose of used batteries according to the manufacturer's instructions. Before disposing of your Grass Valley equipment, please review the *Disposal and Recycling Information* at:

http://www.grassvalley.com/assets/media/5692/Take-Back_Instructions.pdf

Cautions for LCD and TFT Displays



Excessive usage may harm your vision. Rest for 10 minutes for every 30 minutes of usage.

If the LCD or TFT glass is broken, handle glass fragments with care when disposing of them. If any fluid leaks out of a damaged glass cell, be careful not to get the liquid crystal fluid in your mouth or skin. If the liquid crystal touches your skin or clothes, wash it off immediately using soap and water. Never swallow the fluid. The toxicity is extremely low but caution should be exercised at all times.

Mesures de sécurité et avis importants

La présente section fournit des consignes de sécurité importantes pour les opérateurs et le personnel de service. Des avertissements ou mises en garde spécifiques figurent dans le manuel, dans les sections où ils s'appliquent. Prenez le temps de bien lire les consignes et assurez-vous de les respecter, en particulier celles qui sont destinées à prévenir les décharges électriques ou les blessures.

Signification des symboles utilisés



Signale la présence d'une tension élevée et dangereuse dans le boîtier de l'équipement ; cette tension peut être suffisante pour constituer un risque de décharge électrique.



Avertit l'utilisateur, l'opérateur ou le technicien de maintenance que des instructions importantes relatives à l'utilisation et à l'entretien se trouvent dans la documentation accompagnant l'équipement.



Invite l'utilisateur, l'opérateur ou le technicien de maintenance à prendre note du calibre du fusible lors du remplacement de ce dernier. Le fusible auquel il est fait référence dans le texte doit être remplacé par un fusible du même calibre.



Identifie une borne de mise à la terre de protection. Il faut relier cette borne à la terre avant d'effectuer toute autre connexion à l'équipement.

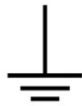

Identifie une borne de mise à la terre externe qui peut être connectée en tant que borne de mise à la terre supplémentaire.



Signale la présence de composants sensibles à l'électricité statique et qui sont susceptibles d'être endommagés par une décharge électrostatique. Utilisez des procédures, des équipements et des surfaces antistatiques durant les interventions d'entretien.



Le symbole ci-contre signifie que l'appareil comporte plus d'un cordon d'alimentation et qu'il faut débrancher tous les cordons d'alimentation avant toute opération d'entretien, afin de prévenir les chocs électriques.



La marque UL certifie que l'appareil visé a été testé par Underwriters Laboratory (UL) et reconnu conforme aux exigences applicables en matière de sécurité électrique en vigueur au Canada et aux États-Unis.



La marque C-CSA-US certifie que l'appareil visé a été testé par l'Association canadienne de normalisation (CSA) et reconnu conforme aux exigences applicables en matière de sécurité électrique en vigueur au Canada et aux États-Unis.



La marque C-UL-US certifie que l'appareil visé a été testé par Underwriters Laboratory (UL) et reconnu conforme aux exigences applicables en matière de sécurité électrique en vigueur au Canada et aux États-Unis.



La marque ETL Listed d'Intertek pour le marché Nord-Américain certifie que l'appareil visé a été testé par Intertek et reconnu conforme aux exigences applicables en matière de sécurité électrique en vigueur au Canada et aux États-Unis.



Le marquage CE indique que l'appareil visé est conforme aux exigences essentielles des directives applicables de l'Union européenne en matière de sécurité électrique, de compatibilité électromagnétique et de conformité environnementale.



Le symbole ci-contre sur un appareil Grass Valley ou à l'intérieur de l'appareil indique qu'il est conforme aux normes applicables en matière de sécurité laser.

Avertissements



Les avertissements signalent des conditions ou des pratiques susceptibles d'occasionner des blessures graves, voire fatales. Veuillez vous familiariser avec les avertissements d'ordre général ci-dessous :

- Un cordon d'alimentation dûment homologué doit être utilisé pour connecter l'appareil à une tension de secteur de 120 V CA ou 240 V CA.
- La protection de ce produit contre les courts-circuits (surintensités) dépend de l'installation électrique du bâtiment. Assurez-vous qu'un fusible ou un disjoncteur pour 120 V CA ou 240 V CA est utilisé sur les conducteurs de phase.
- Dans le présent manuel, toutes les instructions qui nécessitent d'ouvrir le couvercle de l'équipement sont destinées exclusivement au personnel technique qualifié.
- N'utilisez pas cet appareil dans un environnement humide.
- Cet équipement est mis à la terre par le conducteur de mise à la terre des cordons d'alimentation. Pour éviter les chocs électriques, branchez les cordons d'alimentation sur une prise correctement câblée avant de brancher les entrées et sorties de l'équipement.
- Acheminez les cordons d'alimentation et autres câbles de façon à ce qu'ils ne risquent pas d'être endommagés. Supportez correctement les enroulements de câbles afin de ne pas endommager les connecteurs.
- Coupez l'alimentation avant de nettoyer l'équipement. Ne pas utiliser de nettoyeurs liquides ou en aérosol. Utilisez uniquement un chiffon humide.
- Des tensions dangereuses peuvent exister en plusieurs points dans cet équipement. Pour éviter toute blessure, ne touchez pas aux connexions ou aux composants exposés lorsque l'appareil est sous tension.
- Avant de procéder à toute opération d'entretien ou de dépannage, enlevez tous vos bijoux (notamment vos bagues, votre montre et autres objets métalliques).
- Pour éviter tout risque d'incendie, utilisez uniquement les fusibles du type et du calibre indiqués sur l'équipement ou dans la documentation qui l'accompagne.
- Ne pas utiliser cet appareil dans une atmosphère explosive.
- Présence possible de courants de fuite. Un raccordement à la masse est indispensable avant la mise sous tension.
- Après tout travail d'entretien ou de réparation, faites effectuer des contrôles de sécurité par le personnel technique qualifié.

Mises en garde



Les mises en garde signalent des conditions ou des pratiques susceptibles d'endommager l'équipement. Veuillez vous familiariser avec les mises en garde ci-dessous :

- L'appareil est conçu pour être installé dans un endroit à accès restreint.
Remarque: Les restrictions d'accès s'appliquent aux châssis et serveurs de traitement vidéo, et non aux équipements contrôlés par l'opérateur tels que les panneaux de contrôle, les menus, les panneaux auxiliaires, etc.
- Au moment d'installer l'équipement, ne fixez pas les cordons d'alimentation aux surfaces intérieures de l'édifice.

- Les produits qui n'ont pas d'interrupteur marche-arrêt et qui disposent d'une source d'alimentation externe doivent être installés à proximité d'une prise de courant facile d'accès.
- Si l'équipement n'est pas pourvu d'un modules d'alimentation auto-adaptables, vérifiez la configuration de chacun des modules d'alimentation avant de les mettre sous tension.
- Assurez une ventilation adéquate. Pour éviter toute surchauffe du produit, assurez une ventilation de l'équipement conformément aux instructions d'installation.
- N'utilisez pas l'équipement si vous suspectez un dysfonctionnement du produit. Faites-le inspecter par un technicien qualifié.
- Pour réduire le risque de choc électrique, n'effectuez pas de réparations autres que celles qui sont décrites dans le présent manuel, sauf si vous êtes qualifié pour le faire. Confiez les réparations à un technicien qualifié. La maintenance doit se réaliser dans un milieu libre d'électricité statique.
- L'appareil peut comporter plus d'un cordon d'alimentation. Afin de prévenir les chocs électriques, débrancher tous les cordons d'alimentation avant toute opération d'entretien.
- Veillez à toujours prendre les mesures de protection antistatique appropriées quand vous manipulez l'équipement.
- Pour réduire le risque de choc électrique, branchez chaque cordon d'alimentation dans des circuits de dérivation distincts utilisant des zones de service distinctes.

Protection contre les décharges électrostatiques (DES)



Une décharge électrostatique peut se produire lorsque des composants électroniques ne sont pas manipulés de manière adéquate, ce qui peut entraîner des défaillances intermittentes ou endommager irrémédiablement un circuit électrique. Au moment de remplacer une carte dans un châssis, prenez toujours les mesures de protection antistatique appropriées :

- Assurez-vous que le châssis est relié électriquement à la terre par le cordon d'alimentation ou tout autre moyen disponible.
- Portez un bracelet antistatique et assurez-vous qu'il est bien en contact avec la peau. Connectez la pince de masse à une *surface non peinte* du châssis pour détourner à la terre toute tension électrostatique indésirable. En l'absence de bracelet antistatique, déchargez l'électricité statique de votre corps en touchant une surface métallique *non peinte* du châssis.
- Pour plus de sécurité, vérifiez périodiquement la valeur de résistance du bracelet antistatique. Elle doit se situer entre 1 et 10 mégohms.
- Si vous devez mettre une carte de côté, assurez-vous de la ranger dans un sac protecteur antistatique.
- Les cartes qui sont reliées à un châssis ou boîtier métallique mis à la terre ne nécessitent pas de protection antistatique spéciale.

Manipulation de la pile



Ce produit peut inclure une pile de sauvegarde. Il y a un risque d'explosion si la pile est remplacée de manière incorrecte. Remplacez la pile uniquement par un modèle identique ou équivalent recommandé par le fabricant. Disposez des piles usagées conformément aux instructions du fabricant. Avant de vous séparer de votre équipement Grass Valley, veuillez consulter les *informations de mise au rebut et de recyclage* à:

http://www.grassvalley.com/assets/media/5692/Take-Back_Instructions.pdf

Précautions pour les écrans LCD et TFT



Regarder l'écran pendant une trop longue période de temps peut nuire à votre vision. Prenez une pause de 10 minutes, après 30 minutes d'utilisation.

Si l'écran LCD ou TFT est brisé, manipulez les fragments de verre avec précaution au moment de vous en débarrasser. veillez à ce que le cristal liquide n'entre pas en contact avec la peau ou la bouche. En cas de contact avec la peau ou les vêtements, laver immédiatement à l'eau savonneuse. Ne jamais ingérer le liquide. La toxicité est extrêmement faible, mais la prudence demeure de mise en tout temps.

Environmental Information

European (CE) WEEE directive.



This symbol on the product(s) means that at the end of life disposal it should not be mixed with general waste.

Visit www.grassvalley.com for recycling information.

Grass Valley believes this environmental information to be correct but cannot guarantee its completeness or accuracy since it is based on data received from sources outside our company. All specifications are subject to change without notice.

If you have questions about Grass Valley environmental and social involvement (WEEE, RoHS, REACH, etc.), please contact us at environment@grassvalley.com.

Lithium Batteries

Battery Warning

CAUTION

This equipment contains a lithium battery
There is a danger of explosion if this is replaced incorrectly
Replace only with the same or equivalent type.
Dispose of used batteries according to the manufacturer
instructions.
Batteries **shall only** be replaced by trained service technicians.

Your Grass Valley equipment usually comes with at least one button battery located on the main printed circuit board. The batteries are used for backup and should not need to be replaced during the lifetime of the equipment.

Battery Disposal

Before disposing of your Grass Valley equipment, please remove the battery as follows:

- 1 Make sure the AC adapter / power Cord is unplugged from the power outlet.
- 2 Remove the protective cover from your equipment.
- 3 Gently remove the battery from its holder using a blunt instrument for leverage such as a screwdriver if necessary. In some cases the battery will need to be desoldered from the PCB.
- 4 Dispose of the battery and equipment according to your local environmental laws and guidelines.

W A R N I N G

- Be careful not to short-circuit the battery by adhering to the appropriate safe handling practices.
- Do not dispose of batteries in a fire as they may explode.
- Batteries may explode if damaged or overheated.
- Do not dismantle, open or shred batteries.
- In the event of a battery leak, do not allow battery liquid to come in contact with skin or eyes.
- Seek medical help immediately in case of ingestion, inhalation, skin or eye contact, or suspected exposure to the contents of an opened battery.

Laser Safety - Fiber Output SFP and QSFP Modules Warning

LASER SAFETY

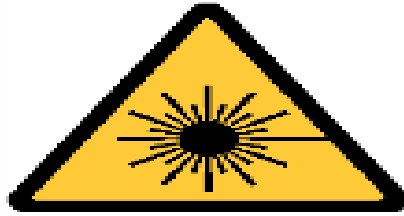

The average optical output power does not exceed 0 dBm (1mW) under normal operating conditions. Unused optical outputs should be covered to prevent direct exposure to the laser beam.

Even though the power of these lasers is low, the beam should be treated with caution and common sense because it is intense and concentrated. Laser radiation can cause irreversible and permanent damage of eyesight. Please read the following guidelines carefully:

- Make sure that a fiber is connected to the board's fiber outputs before power is applied. If a fiber cable (e.g. patchcord) is already connected to an output, make sure that the cable's other end is connected, too, before powering up the board.
- **Do not** look in the end of a fiber to see if light is coming out. The laser wavelengths being used are totally invisible to the human eye and can cause permanent damage. Always use optical instrumentation, such as an optical power meter, to verify light output.

Safety and EMC Standards

This equipment complies with the following standards:

Safety Standards



Information Technology Equipment - Safety Part 1

EN60950-1: 2006

Safety of Information Technology Equipment Including Electrical Business Equipment.

UL1419 (4th Edition)

Standard for Safety – Professional Video and Audio equipment (UL file number E193966)

EMC Standards

This unit conforms to the following standards:

EN55032:2015 (Class A)

Electromagnetic Compatibility of multimedia equipment - Emission requirements

EN61000-3-2:2014 (Class A)

Electromagnetic Compatibility - Limits for harmonic current emissions

EN61000-3-3:2013

Electromagnetic Compatibility - Limits of voltage changes, voltage fluctuations and flicker

EN55103-2:2009 (Environment E2)

Electromagnetic Compatibility, Product family standard for audio, video, audio-visual and entertainment lighting control apparatus for professional use. Part 2. Immunity

WARNING

This equipment is compliant with Class A of CISPR 32. In a residential environment this equipment may cause radio interference.

FCC / CFR 47:Part 15 (Class A)

Federal Communications Commission Rules Part 15, Subpart B

Caution to the user that changes or modifications not expressly approved by the party responsible for compliance could void the user's authority to operate the equipment.

Note: This equipment has been tested and found to comply with the limits for a Class A digital device, pursuant to part 15 of the FCC Rules. These limits are designed to provide reasonable protection against harmful interference when the equipment is operated in a commercial environment. This equipment generates, uses, and can radiate radio frequency energy and, if not installed and used in accordance with the instruction manual, may cause harmful interference to radio communications. Operation of this equipment in a residential area is likely to cause harmful interference in which case the user will be required to correct the interference at his own expense.

EMC Performance of Cables and Connectors

Grass Valley products are designed to meet or exceed the requirements of the appropriate European EMC standards. In order to achieve this performance in real installations it is essential to use cables and connectors with good EMC characteristics.

All signal connections (including remote control connections) shall be made with screened cables terminated in connectors having a metal shell. The cable screen shall have a large-area contact with the metal shell.

SIGNAL/DATA PORTS

For unconnected signal/data ports on the unit, fit shielding covers. For example, fit EMI blanking covers to SFP+ type ports; and fit 75 Ω RF terminators to BNC type ports.

COAXIAL CABLES

Coaxial cables connections (particularly serial digital video connections) shall be made with high-quality double-screened coaxial cables such as Belden 8281 or BBC type PSF1/2M and Belden 1694A (for 3Gbps).

D-TYPE CONNECTORS

D-type connectors shall have metal shells making good RF contact with the cable screen. Connectors having "dimples" which improve the contact between the plug and socket shells, are recommended.

toc

Table of Contents

FCC Compliance	ii
Patent Information	ii
Copyright and Trademark Notice	ii
Safety and EMC Standards	xii
Safety Standards	xii
EMC Standards	xiii
EMC Performance of Cables and Connectors	xiii
1 Introduction	19
Overview	19
Features	19
General	19
K-Frame Standard Frame	20
K-Frame Compact Frame	21
K-Frame Compact S-series Frame	21
K-Frame V-series Frame	21
GV K-Frame X Standard Frame	22
GV K-Frame XP Compact Frame	22
K-Frame Control Surfaces	22
Kayenne Control Surface	22
Flat or Curved Control Panel Orientation	24
Control Panel Stripes	24
Touch Screen Menu Panel	24
Basic Single Suite Kayenne Panel System	25
Multiple Suite Kayenne Panel System Example	25
Karrera Control Surface	27
Basic Single Suite Karrera Panel System	28
GV Korona Control Surfaces	29
Basic Single Suite GV Korona Panel System Example	29
Multiple Suites and Control Surfaces Example	29
Supported Control Protocols	30
2 Frame Installation	33
8-RU (GV K-Frame XP) Video Processor Dimensions	33
8RU Video Processor Installation and Airflow	35
8RU Video Processor Views	36
Compact Power Supply AC Requirements	37
Supplied Power Cables for 8-RU	37
About High Line (208V-240V) Versus Low Line (120V) Operations	38
About Low Line (120V) Operational Considerations	38

3 System Cabling	41
About the GV K-Frame XP System Cabling Section.....	41
System Cabling Overview.....	41
Ethernet Tally Verses Serial Tally	41
Suites and Control Surfaces.....	41
Network Cabling	41
Ethernet Switch	42
Customer Supplied Ethernet Routers and Switches	42
Factory Default Network Settings	43
System Cabling for Kayenne Control Panels	44
Kayenne Network Cabling	44
Kayenne Suites and Control Surfaces.....	45
Kayenne Control Panel Cabling	47
Kayenne M/E and Local Aux Stripe Connections	47
Kayenne Satellite Panel Cabling.....	48
Kayenne Touch Screen Menu Panels (Used with PCU).....	49
System Cabling for the Karrera Control Panel.....	49
Karrera Suites and Control Surfaces	49
Karrera Control Panel Network Cabling.....	50
Optional Touch Screen Menu Panel Cabling	50
Optional Karrera Local Aux Panel Cabling	51
System Cabling for the GV Korona Control Panel	53
GV Korona Suites and Control Surfaces.....	53
GV K-Frame XP Video Cabling	54
10GigE IP I/O Fiber Optic Cabling	54
SDI Inputs.....	54
SDI Outputs	55
Reference Input	55
Supported Media Port Frame Rates	55
ClipStore Cabling.....	55
ClipStore Video Cabling	56
GV K-Frame XP Video Processor Frame GPI/Relay Tally Interface.....	58
GPI and Relay Tally Connections	58
GPI Inputs.....	59
Relay Tally/GPI Outputs.....	59
GPI In, GPI Out, Relay Tally Pin Assignments	61
RS-422/485 Port Pin Assignments	65
RS-232 Port Pin Assignments.....	66
Remote Aux Panels	66
GV-RAP-100 and GV-RAP-200 Remote Aux Panels	66
RAP 100/200 GPI I/O Port Pin Assignments	67
Appendix A Specifications	69
GV K-Frame XP Video Processor Specifications.....	69
Kayenne Control Panel Specifications	73
Karrera Control Panel Specifications.....	75
GV Korona Control Panel Specifications	77

Appendix B Regulatory Notices 79

Certifications and Compliances79
 FCC Emission Control.....79
 Canadian EMC Notice of Compliance.....79
 EN55022 Class A Warning.....79
 Canadian Certified AC Adapter.....79
 FCC Emission Limits80
 Certification.....80
 DEKRA Certificate81

1 Introduction

Overview

The Grass Valley K-Frame family of multi-format digital production switchers provides powerful, ground-breaking features designed to meet the widest range of requirements for live studio, mobile, and post-production applications.

The following Video Processors are the heart of the system, providing extensive video switching and signal processing capabilities:

- Standard
- Compact
- S-series
- V-series
- GV K-Frame X
- GV K-Frame XP

This functionality is controlled using any Control Panel with any Video Processor Frame:

- Kayenne control surface,
- Karrera control surface,
- GV Korona control surface,
- the Soft Panel (KSP option), and/or
- the Menu application running on a PC (Menu on PC).

In addition, the system supports direct control of external devices (DDR, Servers) and bi-directional control to and from routing and automation systems.

Features

General

- Fully digital 10-bit 4:2:2 video switcher including 4K, HDR (HLG and PQ), 1080p, and 2160p support:
 - SDI—1080p level-A or level-B
 - IP I/O—1080p level-A
 - IP I/—2160p (GV K-Frame XP)
- Optional smart I/O modules provide up/down/cross-conversion when licensed with SetDef and MatchDef.
- The K-FRM-IO-10GE IP I/O board for the K-Frame video processing engine offers Video-Over-IP connectivity for all K-Frame Video Production Switchers, using either uncompressed SMPTE 2022-6 or 4K 1-wire compressed IP.

- 4K UHD processed using 2SI (2 Sample Interleave) or SDQS (Square Division Quad Split).
- Integrated Macro Builder/Editor allows users to edit macros online or offline on a PC running the menu application.
- Optional DoubleTake™ (split M/E mode) effectively increases the number of M/Es and adds flexibility to Suites operation while FlexiKey™ programmable clean feed mode supports separately programmable configurations of keyers from four M/E outputs.
- FlexiKey™ programmable clean feed mode supports separately programmable configurations of keyers from four M/E outputs.
- Aux bus transitions for dissolves and wipes on aux bus outputs.
- Interfaces with Grass Valley routers supporting Native Protocol.
- Optional Integrated Image Store capable of delivering up to 32 GB and 64GB storage of Stills (3,000/6,000 images) or “Movies” (a total of 50 seconds or 1 minute 40 seconds) of 1080p video.
- LDK Series and LDX Series camera control with Ethernet tally via Connect Gateway.
- Optional integrated external ClipStore provides multiple channels of video/key pairs for up to 10+ hours of nonvolatile video/key/audio clip content.
- 999 macros with many ways to recall macros from the Control Panel.
- 1,000 E-MEM registers with Define E-MEM for fine control in creation and editing of effects.
- Optional M/E Previewer provides a method to check and monitor any input to an M/E.
- VDCP Ethernet connection for stadium applications.
- Ethernet tally connection for integration with external tally systems.
- Optional RGB color correction on M/E buses and aux bus outputs.
- Source Rules:
 - Links keyers to sources.
 - Settings for On/Off/Left Alone on every M/E.
 - Full look-ahead preview of rules.
- Hot-swappable, front/rear removable modules and power supplies.
- Optional multiple Multiviewer capability with 5 pre-configured layouts (maximum 14 panes per layout) with On-Air and Preview tally.

K-Frame Standard Frame

- Up to 192 inputs and 96 outputs.
- Up to 9 M/Es, accessible across two suites—by using DoubleTake this may be increased to 18 virtual M/Es.
- Every M/E has six keyers with standard keying modes including Chroma Key, a pool of floating 3D iDPMs, and two frame stores per keyer—the Controller M/E cannot use floating 3D iDPMs.
- 2D-DPMs (resizers) on every keyer, with 6 pairs per M/E so iDPMs can be utilized for more complex effects.
- The Controller M/E has a complement of 6 full keyers with Chroma Key and 2D-DPMs.

- Up to 16 iDPMs (Integrated Digital Picture Manipulators), assigned as either floating iDPMs or within an eDPM at user's discretion.

K-Frame Compact Frame

- Up to 80 inputs and 48 outputs.
- Up to 5 M/Es, accessible across two suites, increased to 10 virtual M/Es by using DoubleTake.
- Every M/E has six keyers with standard keying modes including Chroma Key, two frame stores per keyer—every keyer except for Controller M/E can use the pool of floating 3D iDPMs.
- 2D-DPMs (resizers) on every keyer.
- The Controller M/E has a complement of 6 full keyers with Chroma Key and 2D-DPMs.
- Up to 8 iDPMs (Integrated Digital Picture Manipulators), assigned as either floating iDPMs or within an eDPM at user's discretion.
- K-Frame Compact S-series Frame (Differences)
- Up to 6 M/Es, accessible across two suites, increased to 12 virtual M/Es by using DoubleTake.
- Every M/E has four keyers with standard keying modes including Chroma Key and every keyer can use the pool of floating 3D iDPMs (Key Stores are not available).
- 2D-DPMs (resizers) on every keyer.
- Two built-in multiviewers with five pre-configured layouts (maximum 14 panes per layout) and On-Air/Preview tally.

K-Frame Compact S-series Frame

- Up to 80 inputs and 48 outputs.
- Up to 6 M/Es, accessible across two suites, increased to 12 virtual M/Es by using DoubleTake.
- Every M/E has four keyers with standard keying modes including Chroma Key—every keyer can use the pool of floating 3D iDPMs.
- 2D-DPMs (resizers) on every keyer, with 4 Video/Key pairs per M/E.
- The Controller M/E has a complement of 6 full keyers with Chroma Key and 2D-DPMs.
- Up to 8 iDPMs (Integrated Digital Picture Manipulators), assigned as either floating iDPMs or within an eDPM at user's discretion.
- Two Built-in multiviewers with five pre-configured layouts (maximum 14 panes per layout) with On-Air and Preview tally.

K-Frame V-series Frame

- Up to 32 SDI inputs and 16 SDI outputs.
- Up to four Media Port inputs and two Media Port outputs.
- Up to 3 M/Es plus 2 VPEs, accessible across two suites, increased to 10 virtual M/Es by using DoubleTake.

- Every M/E and VPE has four keyers with standard keying modes including Chroma Key—every keyer can use the pool of floating 3D iDPMs.
- 2D-DPMs (resizers) on every keyer, with 4 Video/Key pairs per M/E and VPE.
- Up to 4 iDPMs (Integrated Digital Picture Manipulators), assigned as either floating iDPMs or within an eDPM at user's discretion.
- Two Built-in multiviewers with five pre-configured layouts (maximum 14 panes per layout) with On-Air and Preview tally.

GV K-Frame X Standard Frame

- Up to 192 inputs and 96 outputs.
- Up to 9 M/Es, accessible across two suites—by using DoubleTake this may be increased to 18 virtual M/Es.
- Every M/E has six keyers with standard keying modes including Chroma Key, two frame stores per keyer—every keyer except for Controller M/E can use the pool of floating 3D iDPMs.
- 2D-DPMs (resizers) on every keyer, with 6 Video/Key pairs per M/E so iDPMs can be utilized for more complex effects.
- The Controller M/E has a complement of 6 full keyers with Chroma Key and 2D-DPMs.
- Up to 16 iDPMs (Integrated Digital Picture Manipulators), assigned as either floating iDPMs or within an eDPM at user's discretion.

GV K-Frame XP Compact Frame

- Up to 80 inputs and 40 outputs.
- Up to 9 M/Es, accessible across two suites—by using DoubleTake this may be increased to 18 virtual M/Es.
- Every M/E has six keyers with standard keying modes including Chroma Key, two frame stores per keyer—every keyer except for Controller M/E can use the pool of floating 3D iDPMs.
- 2D-DPMs (resizers) on every keyer with Pivot and Perspective, with 6 Video/Key pairs per M/E so DPMs can be utilized for more complex effects.
- The Controller M/E has a complement of 6 full keyers with Chroma Key and 2D-DPMs.
- Up to 16 iDPMs (Integrated Digital Picture Manipulators), assigned as either floating iDPMs or within an eDPM at user's discretion.

K-Frame Control Surfaces

Kayenne Control Surface

A Kayenne control surface typically consists of a Control Panel, a Menu Panel with an included articulated support arm, a Panel Control Unit (PCU) frame, and optional Satellite

Panels. This control surface has an innovative modular design. Representative Kayenne control surfaces are shown in the following illustrations.

4-ME 35 Control Panel

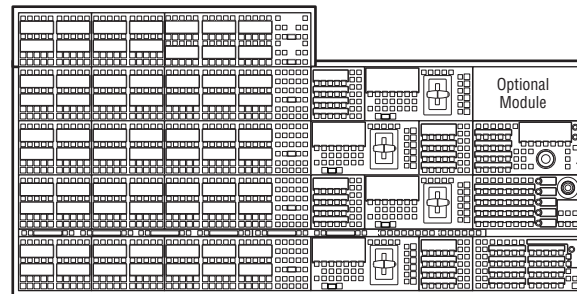

Menu Panel

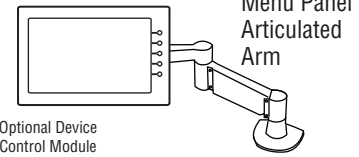

Optional Device Control Module

Panel Control Unit (PCU)

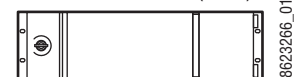

3-ME 35 Control Panel

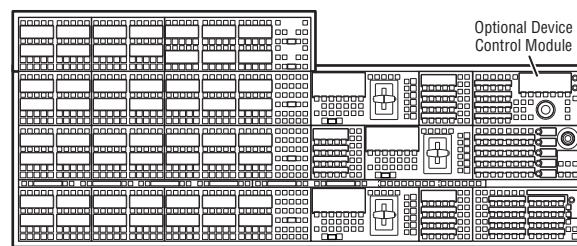

Menu Panel

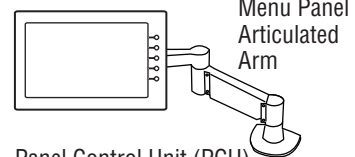

Panel Control Unit (PCU)



2-ME 25 Control Panel

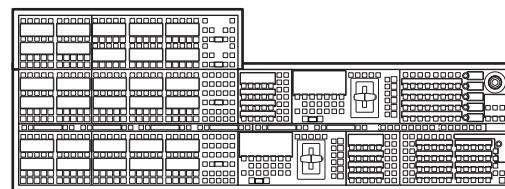

Menu Panel

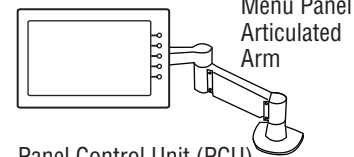

Panel Control Unit (PCU)

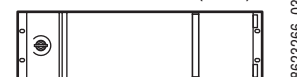

1-ME 15 Control Panel

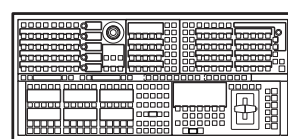

Menu Panel

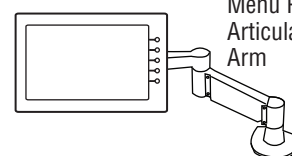

Menu Panel Articulated Arm

Panel Control Unit (PCU)



The modular design and use of a separate PCU supports the hot-replacement of individual Control Panel components, if necessary, while the rest of the system remains operational.

CAUTION: Do not connect or disconnect the PCU to Control Panel cables while the system is powered on.

Flat or Curved Control Panel Orientation

The main Kayenne Control Panel supports different physical orientations. Besides a conventional flat surface, a special support design permits a curved working surface, where the M/Es progressively tilt for improved ergonomics.

Curved Control Panel Assembly

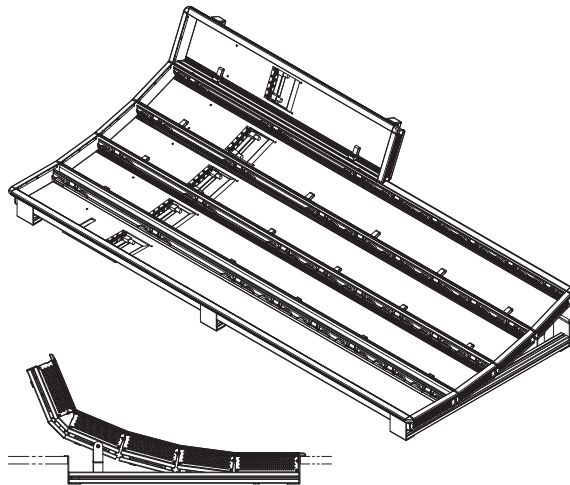

Flat Control Panel Assembly

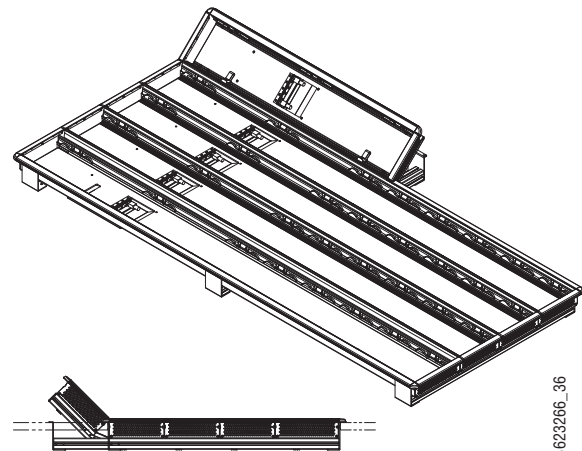

8623266_36

Control Panel Stripes

The main Kayenne Control Panel is organized into from one to five Stripes. Each Stripe consists of a tray and its complement of drop-in modules. An M/E Stripe has a module for Source Selection, Transition, and individual E-MEM control. Additional Master E-MEM, Machine Control, Multi-Function, and Local Aux modules are populated to complete the control surface functionality.

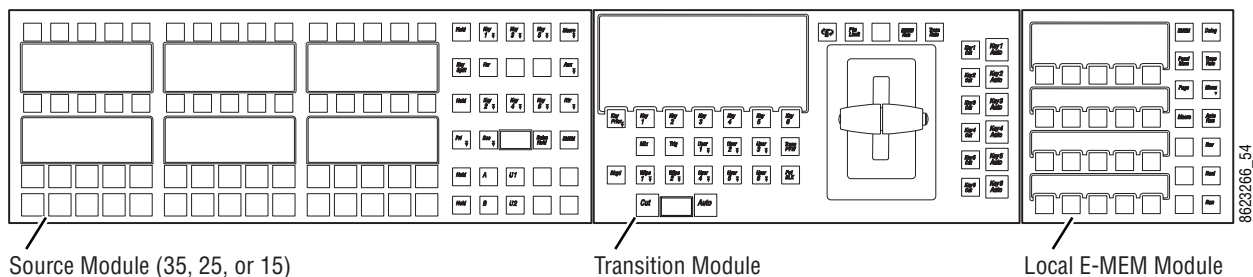

8623266_54

Touch Screen Menu Panel

Each Kayenne control surface includes a Menu Panel that features a wide format 15 in. touch screen display. An articulated arm is also included, offering a wide variety of installation options. The Menu Panel has a standard VESA-75 hole pattern and M4 threads, compatible with this and many other mounting devices.

The Menu Panel has four USB ports, two on the right side edge of the panel and two on the back for keyboard and mouse (wired or wireless are supported).

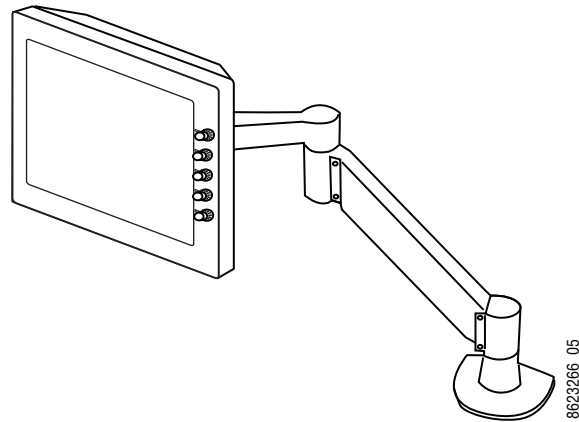

Basic Single Suite Kayenne Panel System

A basic K-Frame system consists of a Control Panel, a Menu application running on a touch screen Menu Panel, and a Video Processor Frame. The Control Panel and Menu application make up a control surface associated with that frame. The Kayenne Control Panel and Menu Panel have associated active electronics housed in the Panel Control Unit (PCU).

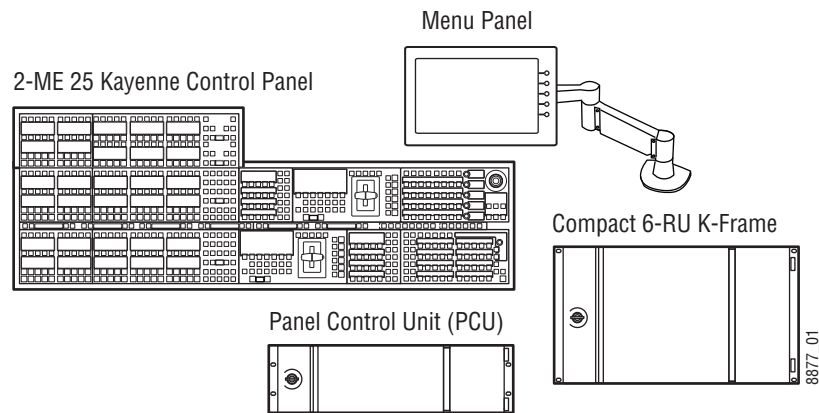

Multiple Suite Kayenne Panel System Example

A K-Frame system can be subdivided into two suites, if desired, each of which can have two control surfaces (Surface A and Surface B). Each surface has its own set of Panel Preferences for configuration of the control panel behavior and independent macro systems to allow for independent building and running of macros by each operator at the control surface.

Hardware resources in the Video Processor Frame can be assigned to an individual suite during configuration, essentially creating two separate switchers sharing one frame.

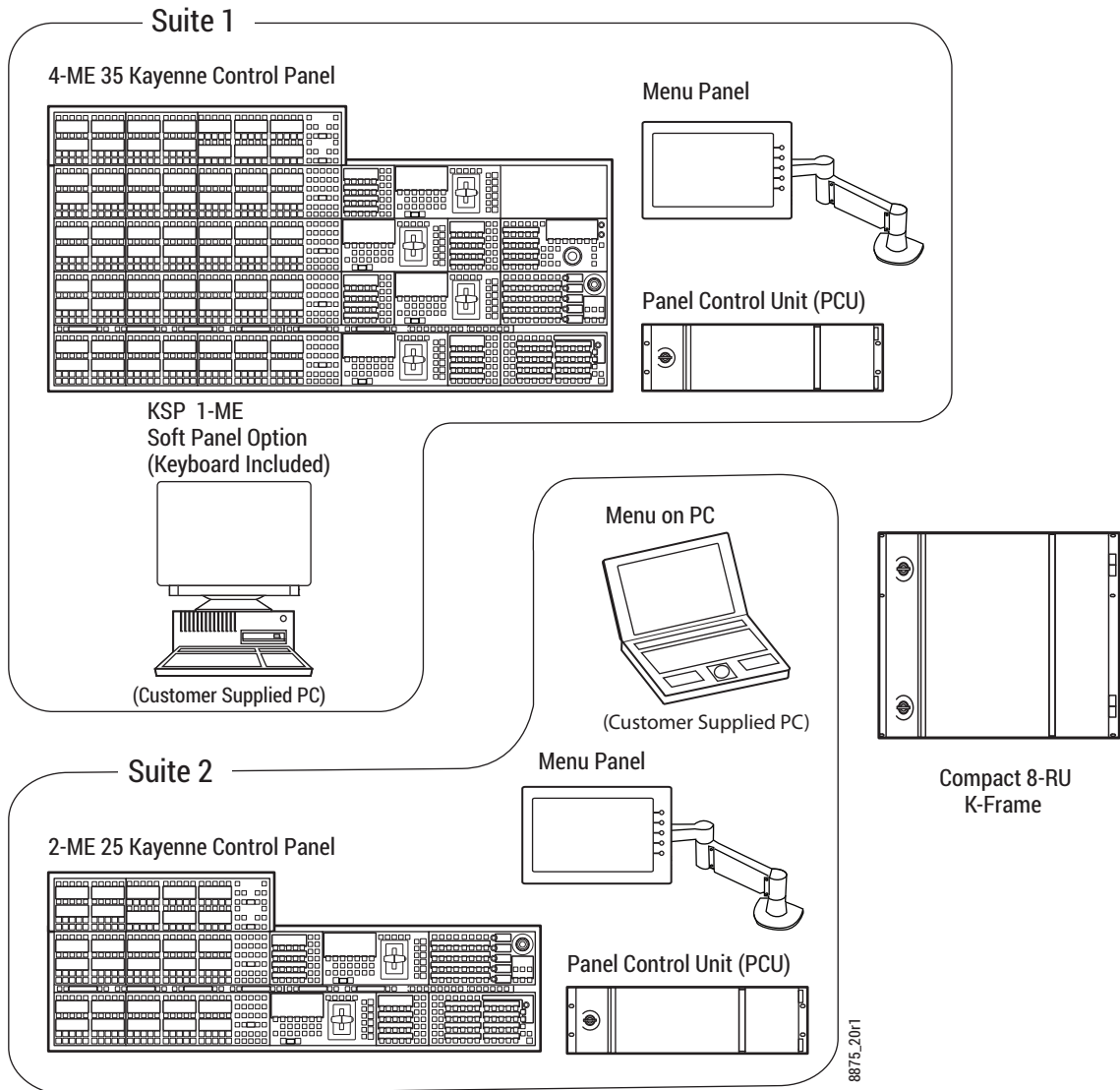

Karrera Control Surface

A Karrera control surface typically consists of a Control Panel and a Menu application. Representative Karrera control surfaces are shown in the following illustrations.

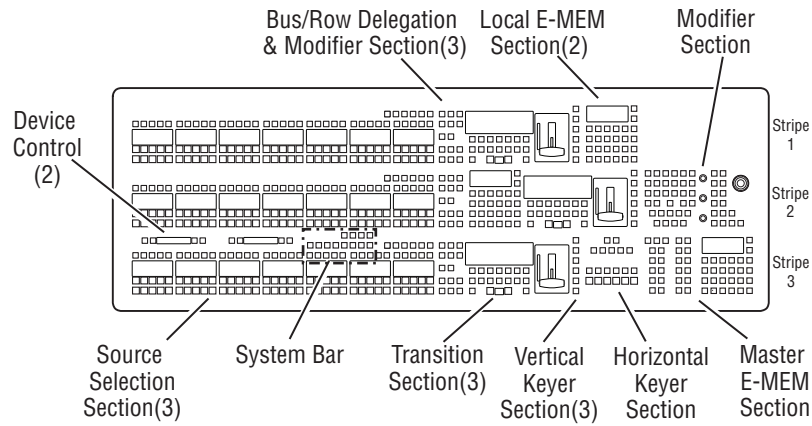

Karrera 2-ME 25 Control Panel

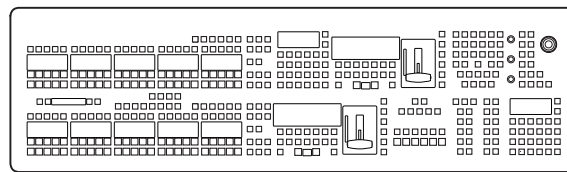

Karrera Menu on PC



(Customer Supplied PC) 8623266_03_Krr

Touch Screen Menu Option

A hardware Karrera Menu Panel is available as an option, which features a wide format 15 in. touch screen display. An articulated arm is also included, offering a wide variety of installation options.

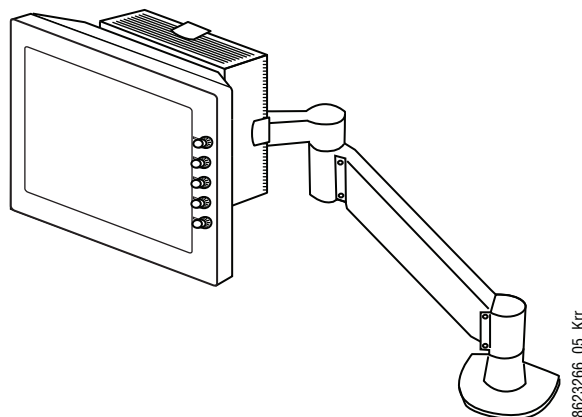

8623266_05_Krr

The Menu Panel has a standard VESA-75 hole pattern and M4 threads, compatible with this and many other mounting devices. The Menu Panel also has four USB ports, two on the right side edge of the panel and two on the back for keyboard and mouse (wired or wireless are supported).

A fanless PC, running Windows OS, is available which mounts behind the Menu Panel.

Basic Single Suite Karrera Panel System

A basic Karrera K-Frame system consists of a Control Panel, a Menu application running on a PC, and a Video Processor Frame. The Control Panel and Menu application make up a control surface associated with that frame.

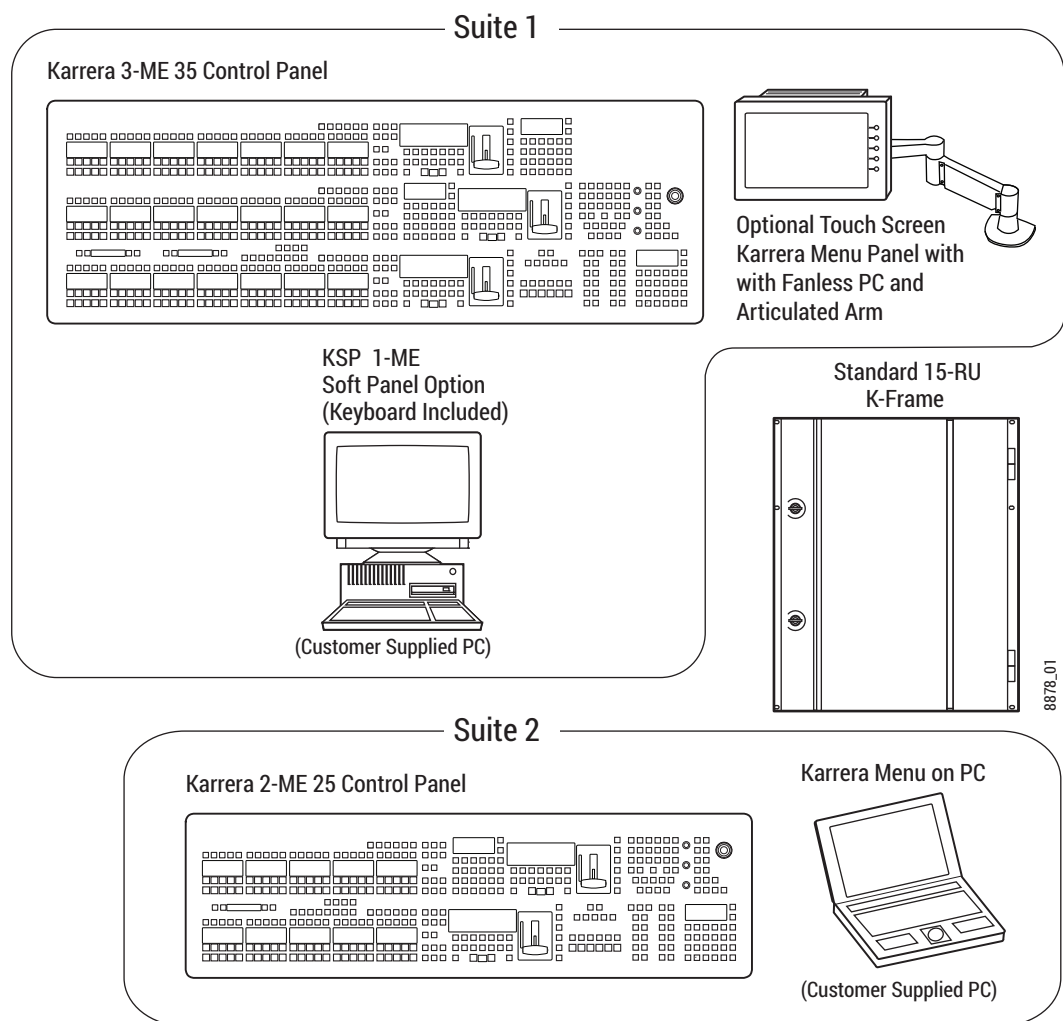

GV Korona Control Surfaces

A GV Korona control surface consists of a Control Panel with Source Select, Transition, Delegation, and Master/Local E-MEM areas, and a built-in multi-touch display with menu system.



Basic Single Suite GV Korona Panel System Example

GV Korona 2-M/E 20 Control Panel

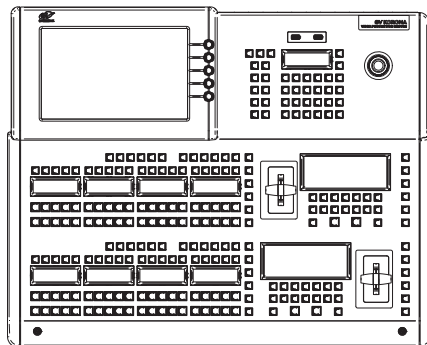

K-Frame V-series 3-RU

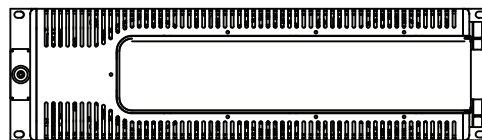

6600_0411

Multiple Suites and Control Surfaces Example

Any K-Frame Kayenne, Karrera, or GV Korona Control Panel can be configured with any K-Frame Video Processor. The K-Frame system can be subdivided into two suites and each suite can have up to two control surfaces. Hardware resources in the Video Processor Frame can be assigned to an individual suite during configuration, essentially creating two

separate switchers sharing one Frame. See the K-Frame Installation & Service Manual for suite configuration information.

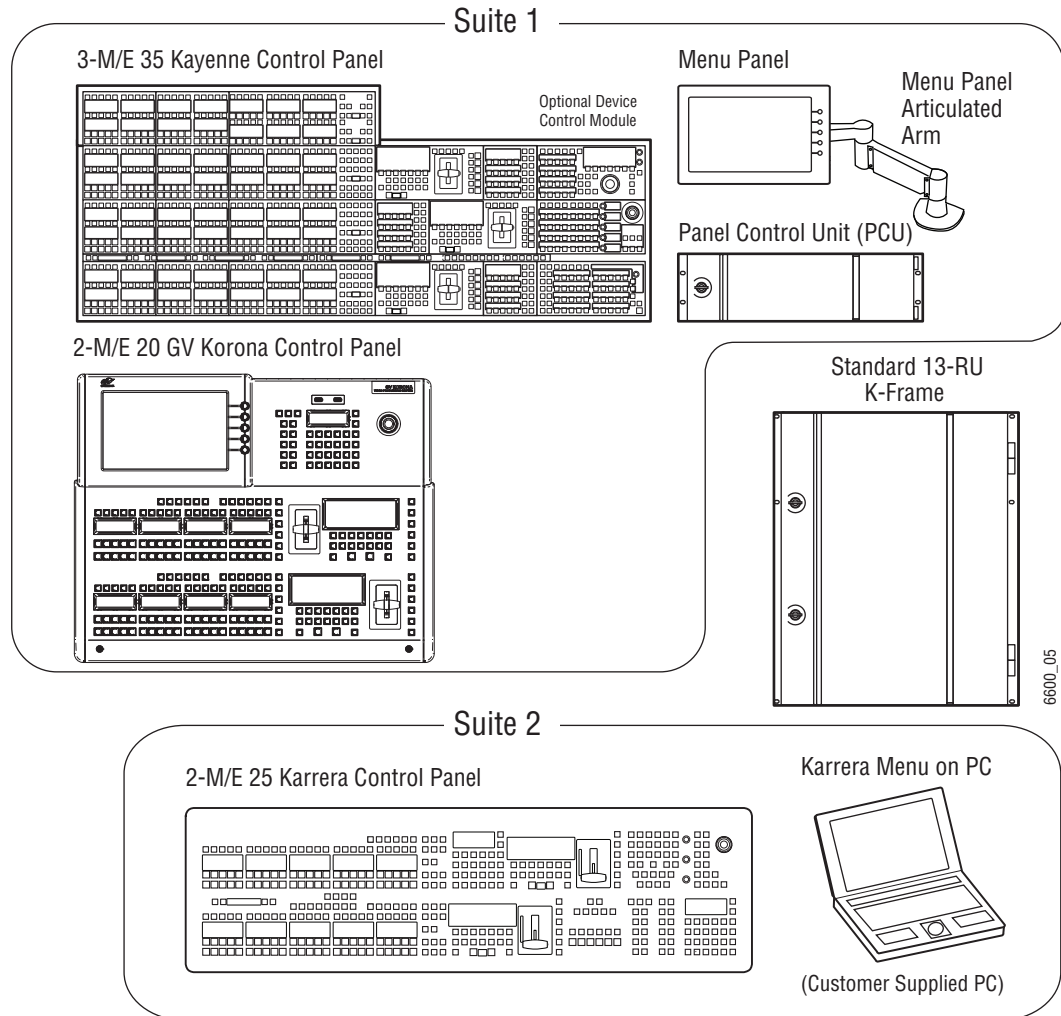

Supported Control Protocols

- PBus II
- GPI Inputs and Outputs
- Serial BVW-75 for VTR control
- Odetics protocol for VTR control
- AMP (advanced media protocol) for Profile PVS, Profile XP Media Platform, K2, M-Series, Turbo iDDR, and T2 iDDR systems over Ethernet
- Grass Valley Native Protocol for routers/routing control systems (Trinix/Trinix NXT, Venus™, Triton™, and third-party routers; Jupiter NV9000 and NV920, and Encore router control systems)
- Tally (contact closure)

- K-Frame Ethernet Tally protocol
- Ethernet CPL to control Grass Valley external remote AUX Panels
- Grass Valley Editor protocol
- SNMP system monitoring
- Serial and Ethernet VDCP
- LDK Series & LDX Series™ camera control with Ethernet tally via Connect Gateway

2 Frame Installation

8-RU (GV K-Frame XP) Video Processor Dimensions

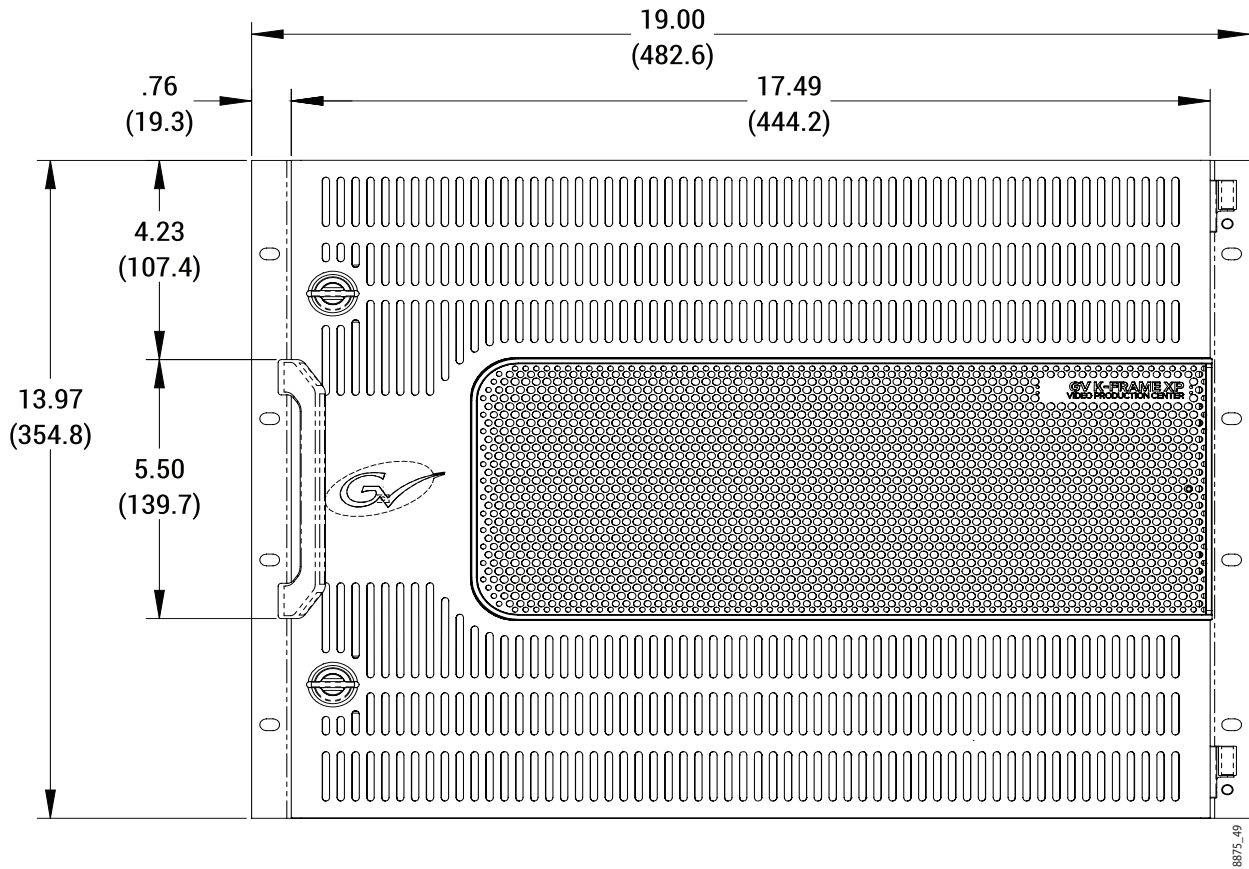

8-RU Dimensions (Front View)

CAUTION: Mounting a GV K-Frame XP in a rack immediately below equipment that extends forward from the rack may not provide enough clearance to completely remove the door.

Frame Installation

8-RU (GV K-Frame XP) Video Processor Dimensions

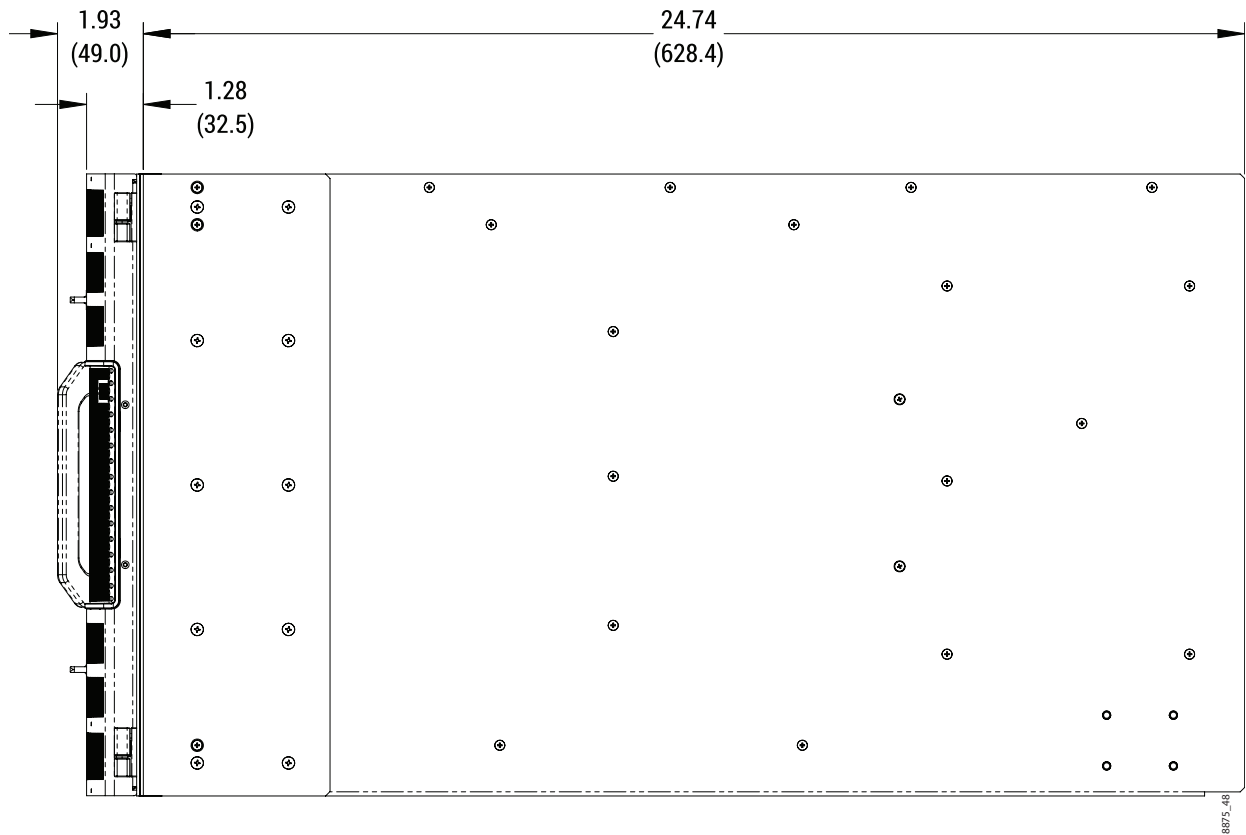

8-RU Dimensions (Side View)

8RU Video Processor Installation and Airflow

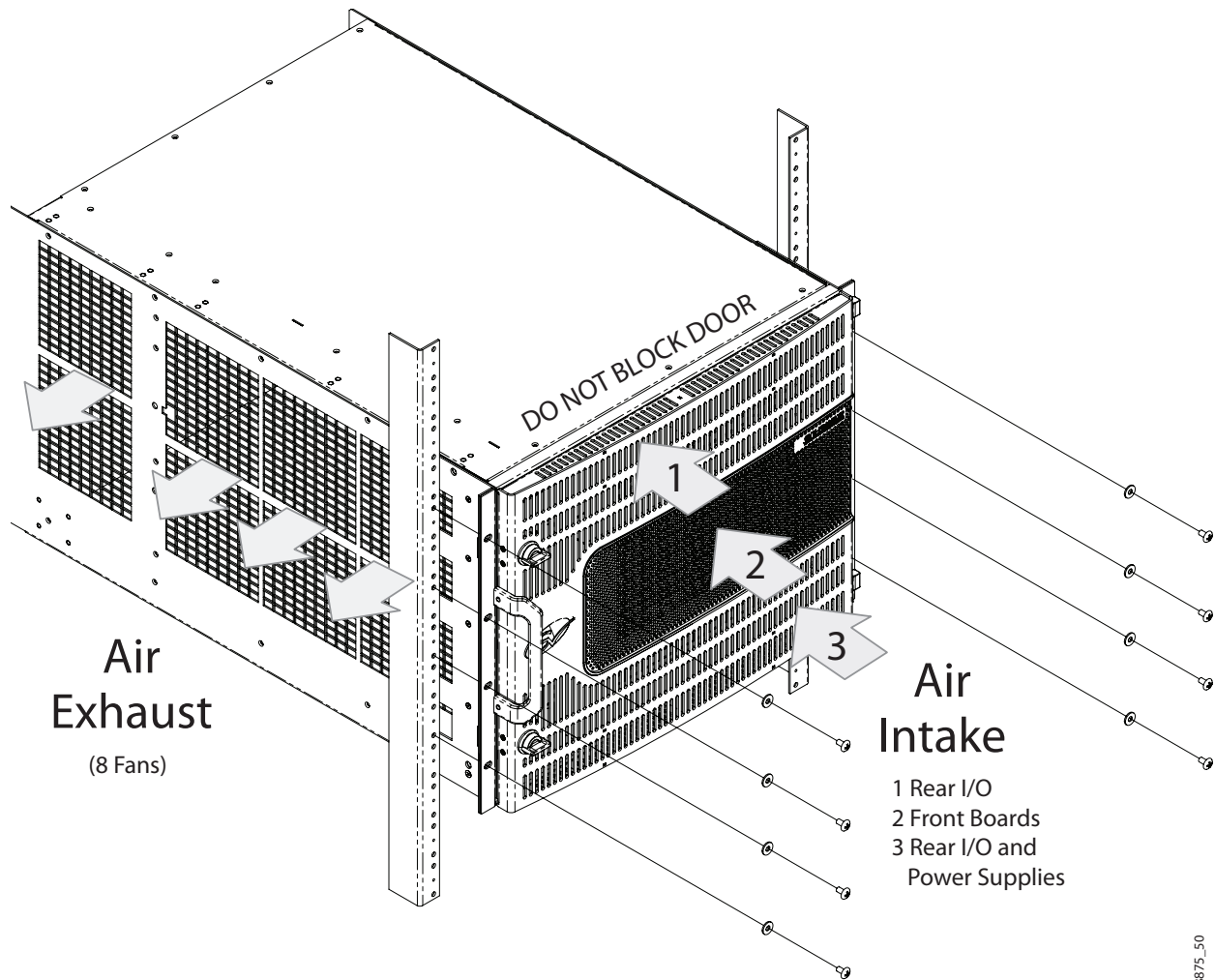

8-RU Rack Mounting and Cooling Airflow

8875_50

8RU Video Processor Views

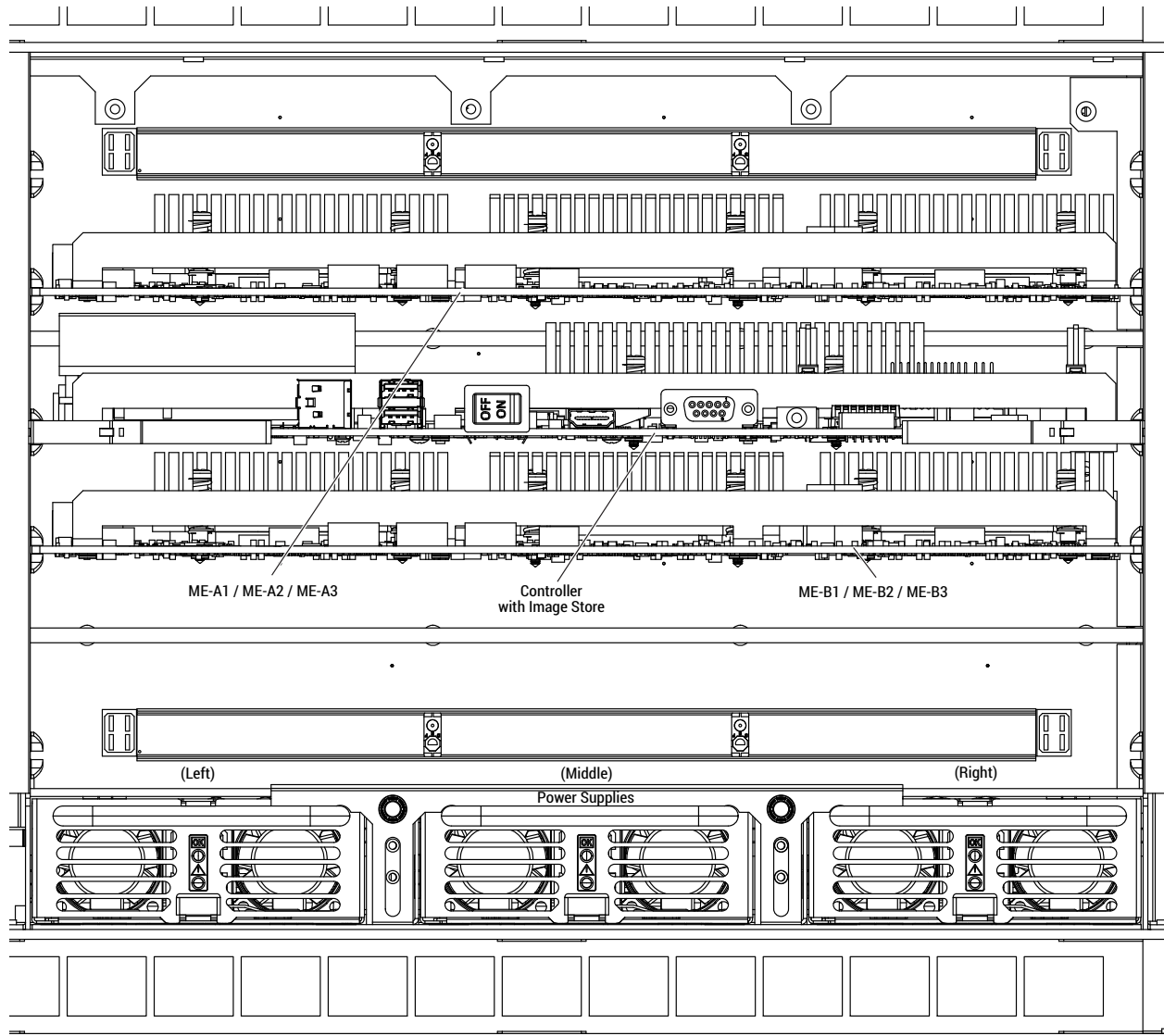

8-RU, Front View with Door Removed

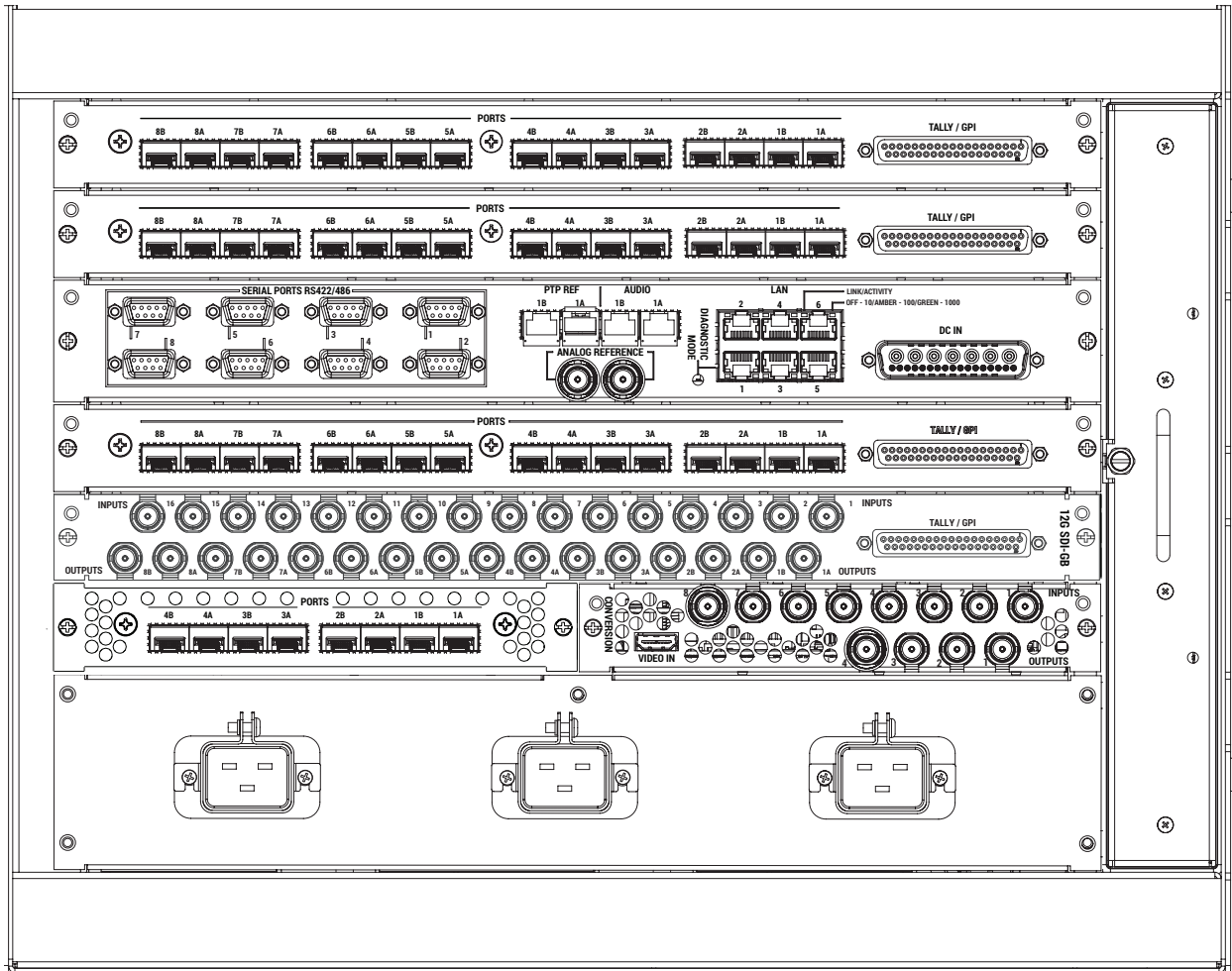

8-RU, Rear View IP/Gearbox/Conversion

Compact Power Supply AC Requirements

The GV K-Frame XP 8-RU Power Supplies have provision to support up to three hot swappable power modules. These convert the AC line input to 48V DC for the Video Processor Frame. The cells for the three modules (referred to as left, center, right) are identical and any or all cells can have a module installed. Each cell has its own AC line cord. The supplies are power factor corrected and automatically accommodate low line (120V nominal) or high line (240V nominal). The power supplies have a rating of 90-140V AC for low line and 180-240V AC high line to accommodate under and over voltage conditions.

The 8RU Frame is supplied with two power modules. A third power module can be fitted as a redundant (n+1) power supply option.

Supplied Power Cables for 8-RU

The GV K-Frame XP Compact Power Supply Frame has IEC C19 sockets, instead of the more common C13 style, to accommodate potentially higher currents. Cables provided with the

systems are matched to the destination country's standard. For example, in the USA C19 to NEMA 5-20P cables are provided.

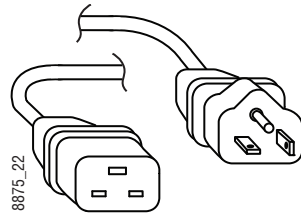

USA Power Cable Example

About High Line (208V-240V) Versus Low Line (120V) Operations

North American users usually have a choice to use low line (120 volts) or high line (208-240 volts) as the AC source. If Low line is used, an 8RU Compact Frame with all options installed and running at 120 volts will draw a total of approximately 15 amps from the line cords. At 100 volts, this increases to approximately 18 amps. This load will be evenly distributed among the line cords.

IMPORTANT: Each line cord must be serviced by a dedicated 20 amp circuit. Two power supplies on the same circuit could exceed 20 amps. With a fully loaded system, a third power supply is needed for redundancy.

The possibility of drawing as much as 15 amps from a line cord explains the 20 amp (NEMA 5-20P) plug on the line cords supplied. The NEC in the US specifies that the ubiquitous 15 amp outlet be de-rated to 12 amps for continuous loads. A 20 amp outlet is needed for the rare case of a 15 amp load experienced during a fault condition.

Most of the above is not an issue if high line (240V) operation is used. Since AC line currents are approximately half of those at low line, exceeding the current rating of a circuit should not be a problem. In areas where there is a choice between high line or low line operation, the user should consider the advantages and disadvantages of each power sourcing scheme.

About Low Line (120V) Operational Considerations

If low line (120V) operation is used (mostly in North America) three characteristics of the switcher should be kept in mind when provisioning AC power for the system, which will result in the most reliable system possible:

- Consider brown-out—Modern switching power supplies are constant power devices and as such, unlike resistive loads, the input current increases as the input voltage decreases.
- Consider power supply failure—If two or three power modules are present, they will load share. For instance, if two modules are fitted and the total AC line current is 10 amps, each of the two line cords will draw about 5 amps. If one supply fails, the other

supply takes up the entire load. At this point, one line cord will draw 0 amps and the other cord will draw 10 amps.

Consider future options—The total AC power consumption is significantly influenced by the number and type of hardware options installed. This includes the number of boards: M/Es, I/Os, and Modular I/Os.

3 System Cabling

About the GV K-Frame XP System Cabling Section

This section provides overview information that is common to all GV K-Frame XP systems as well as information specific to Kayenne, Karrera, and GV Korona Control Panels and components.

System Cabling Overview

The GV K-Frame XP systems use Ethernet, serial, and USB connections and custom multi-pin cables for systems with Kayenne Control Panels. The GV K-Frame XP Video Processors have built-in Ethernet switches. Each Video Processor has Tally outputs and GPI I/O (General Purpose Interface Input/Output) control available.

Ethernet Tally Verses Serial Tally

Our GV K-Frame XP tally system provides significantly more information than the bandwidth of the serial connection. Therefore, we support Ethernet tally only. However, many tally vendors do support our Ethernet tally system so contact your tally vendor for GV K-Frame XP Ethernet tally support information.

Suites and Control Surfaces

A GV K-Frame XP system can be divided into multiple suites. The Video Processor resources (M/Es, eDPMs, external devices, etc.) can be assigned to each suite, creating multiple switchers with one Frame. Each suite can be subdivided into two control surfaces, using Kayenne, Karrera, and GV Korona Control Panels, Soft Panels, and Menu on PC. Each control surface is intended for use by a single operator. The Control Panel system flexibility permits locating these control surfaces in physically separate locations.

Network Cabling

The Ethernet switches built into the GV K-Frame XP Video Processor and PCU (Kayenne only) auto-detect speed and polarity, and are 10/100/1000 Mbps capable. Either straight-through or crossover Ethernet cabling can be used. Available Ethernet connectors may be connected to the Facility LAN or other devices, as needed. However, should the Video Processor or PCU power down, the internal Ethernet switches will also power down, interrupting communication to devices connected to that Frame's or PCU's internal Ethernet switches. Only connect devices that are GV K-Frame XP system related.

Ethernet Switch

The Ethernet switch built into the GV K-Frame XP auto-detects speed and polarity, and is 10/100/1000 Mbps capable. Either straight-through or crossover Ethernet cabling can be used. Available Ethernet connectors may be connected to the Facility LAN or other devices, as needed. However, should the Frame power down, the internal Ethernet switch will also power down, interrupting communication to devices connected to that Frame's internal Ethernet switch. Only connect devices that are system related.

Customer Supplied Ethernet Routers and Switches

Existing facility Ethernet switches can be used in conjunction with a switcher system. If connecting to a network area outside that used by the switcher system, use of an appropriately configured Ethernet Router is strongly advised. This reduces network traffic on the GV K-Frame XP network and keeps it isolated. Any Ethernet switches added specifically for use with the switcher system should be 1000 Mbps capable for the most efficient operation.

Ethernet Specifications

Cables	Type	10BaseT, 100BaseT, 1000BaseT compatible Category 5 cable, 8 conductor twisted pair The system will work at lower ratings with reduced performance. 1000BaseT components are highly recommended.
	Connectors	RJ-45 male connector at each end of cable.
	Length	100BaseT, 1000BaseT: 328 ft. (100 m) maximum. 10BaseT: 984 ft. (300 m) maximum. Use additional switches to exceed maximum cable runs.
Switch	Speed	10/100/1000 Mbps
	Ports	RJ-45 auto-negotiating 10/100/1000 Mbps; number of ports required is dependent upon system size. Frame and PCU ports are capable of 1000 Mbps. Using a 1000 Mbps Ethernet switch enhances Image Store transfer speeds.
	Unmanaged	Recommended. Configuration not required, but does not provide remote monitoring capability.
	Managed	May be used. Requires configuration, but offers remote monitoring capability.

To integrate GV K-Frame XP devices into an existing network, ask the local network administrator for that network's subnet mask. Before changing IP addresses always set the subnet masks of the GV K-Frame XP devices to the mask of the local network.

Factory Default Network Settings

GV K-Frame XP System Default IP Addresses

Devices	IP Address
Video Processor Frame CPU	192.168.0.170
Image Store CPU	192.168.0.171
Control Panel Surface 1A	192.168.0.173
Touch Screen Menu Panel 1 (Kayenne/Karrera)	192.168.0.175
Touch Screen Menu Panel 2 (Kayenne/Karrera)	192.168.0.176
Control Panel Surface 1B	192.168.0.177
Control Panel Surface 2A	192.168.0.178
Control Panel Surface 2B	192.168.0.179
Clip Store	192.168.0.180
Kayenne/Karrera only: 32-Crosspoint Remote Aux Panels V1.6.5 and higher software: (hard reset with the front panel buttons)	IP Address: 192.168.1.2 Frame IP: 192.168.1.1 Gateway IP: 192.168.1.1 Subnet Mask 255.255.255.0 Note: 32-Crosspoint Remote Aux Panel default settings must be changed to operate with a Kayenne/Karrera system whose other components are configured with their default IP addresses.
All Subnet Masks)	255.255.255.0
All Gateways (except V1.6.5 software Remote Aux panel)	192.168.0.1
Following Reserved For Future Use	CAUTION: Do not connect any devices configured with the following IP addresses to a GV K-Frame XP network.
Video Processor Frame Gigabit Ethernet	192.168.0.172
PCU Panel Reserved LAN Port	192.168.0.174

Note: Customer orders with multiple Control Panels will be pre-configured to the listed IP addresses. However, if one of these additional Control Panels is reset to factory defaults, it will be given the standard 1A default 192.168.0.173 address.

To integrate GV K-Frame XP system devices into an existing network, ask the local network administrator for that network's subnet mask. Before changing IP addresses always set the subnet masks of the devices to the mask of the local network.

System Cabling for Kayenne Control Panels

USB, Ethernet, and custom multi-pin cabling is used to connect the Kayenne Video Processing Frame, Panel Control Unit (PCU), Control Panel, and Menu Panel components.

In addition to the Video Processing Frame, the PCU also includes a built-in Ethernet Switch.

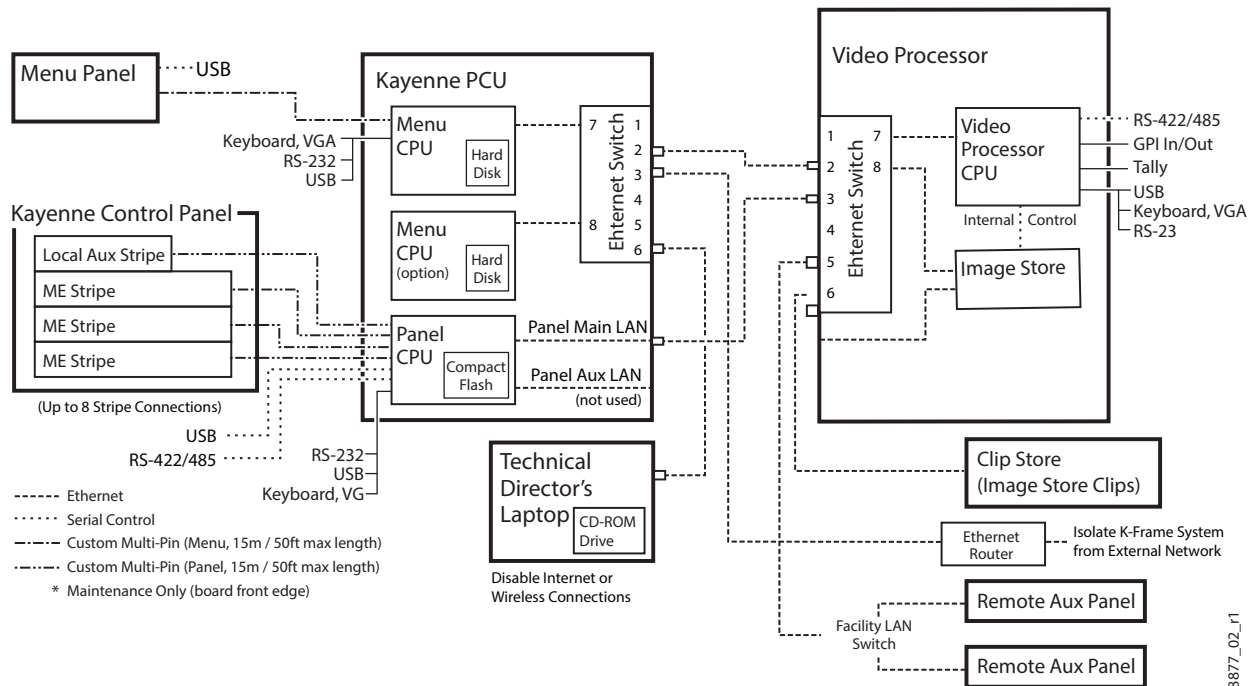

Kayenne GV K-Frame XP System Communications Overview

CAUTION: The facility network used for your GV K-Frame XP system (and other video production equipment) should be kept separate from any external network, to prevent network traffic from adversely affecting system operation.

Kayenne Network Cabling

Network connections are required between the GV K-Frame XP Video Processor and the PCU. The PCU routes network communications to and from the Control Panel Stripes and Menu Panels, using custom multi-pin cables.

The use of two Ethernet cables to connect the PCU to the Video Processor is recommended.

Two Cable PCU Frame Connection

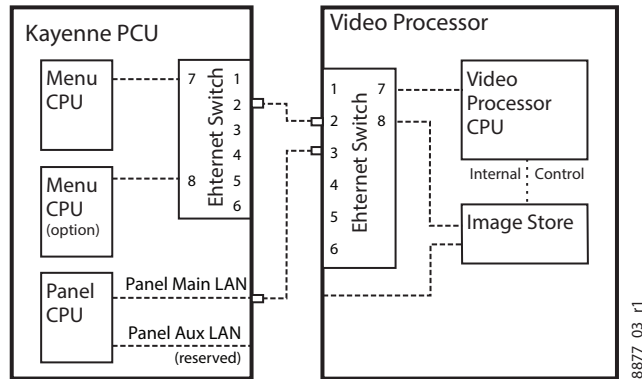

PCU to Kayenne GV K-Frame XP Network Connection Methods

The PCU Ethernet switch to GV K-Frame XP Video Processor Ethernet switch cable connection is used for Menu Panel communications. The second cable connects the Panel PCU directly to the Frame's Ethernet switch. Using two cables provides additional Ethernet communications throughput (to support Image Store file operations) and also offers redundancy. Because the Menu Panel and the Control Panel have independent cable connections, failure of one of these cables will not completely disable the system. Either the Menu Panel or the Control Panel will remain operational after a single network cable failure.

Kayenne Suites and Control Surfaces

The GV K-Frame XP Control Panel system flexibility allows you to locate control surfaces in physically separate locations.

Custom multi-pin cable runs are limited to 15 meters (50 ft.) If this length is sufficient, a single PCU can be used for an entire multi-suite system.

System Cabling

Kayenne Suites and Control Surfaces

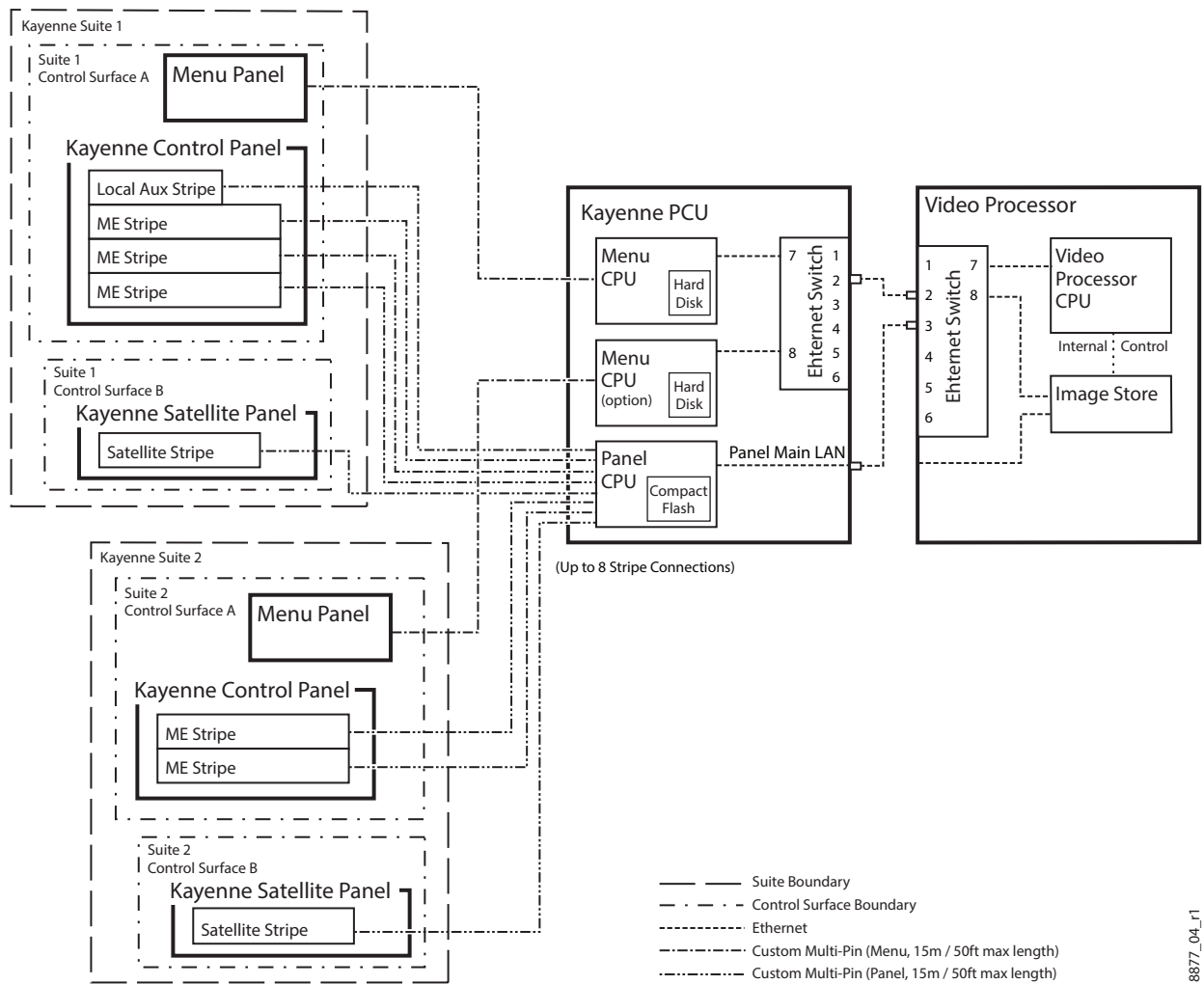

Two Kayenne GV K-Frame XP Suites with Two Control Surfaces Using One PCU

Using a second PCU, GV K-Frame XP suites can be located anywhere on the network, permitting system control from different rooms, floors, or even different buildings.

8877_04_r1

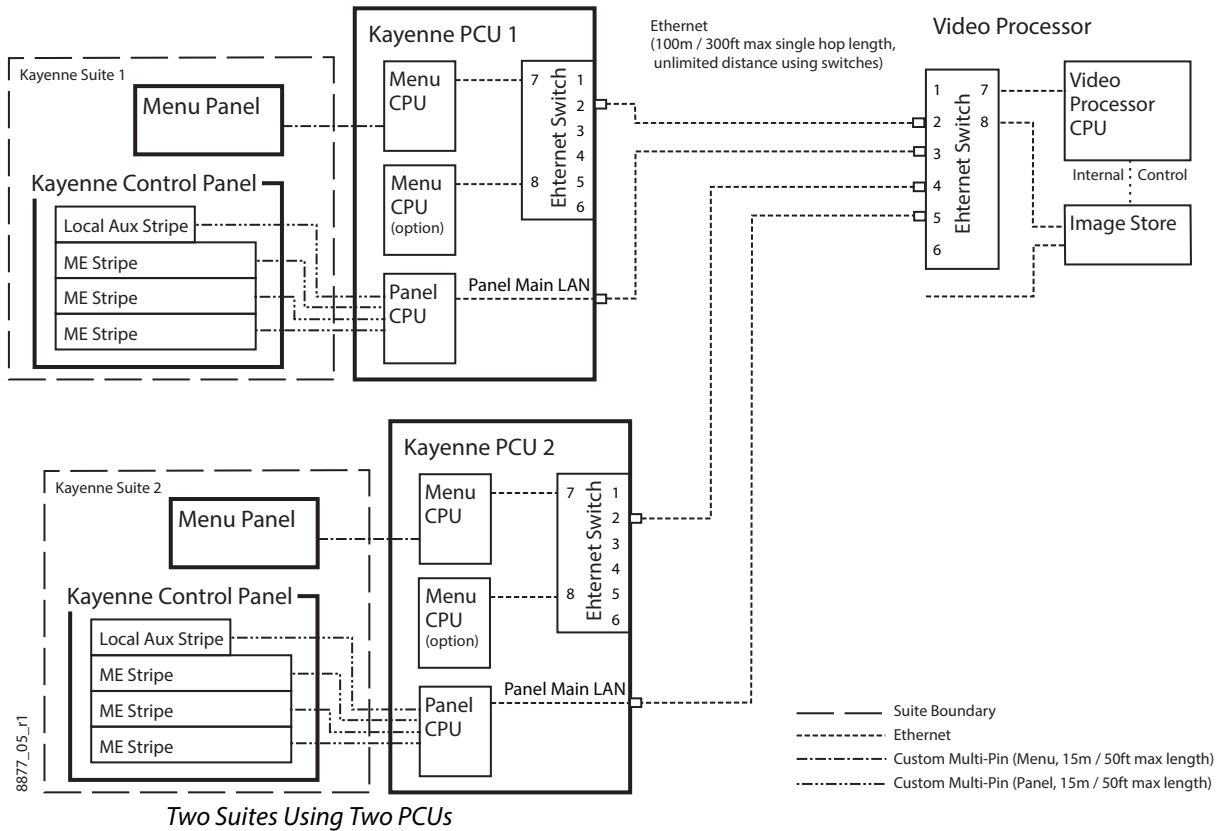

Kayenne Control Panel Cabling

Connectors on the outside bottom of the Control Panel tray connect to numbered ports on the PCU, using special multi-pin cables that carry both power and communications signals. Special cables are also used to connect the Menu Panels to the PCU.

CAUTION: Do not connect or disconnect the multi-pin cables linking a Kayenne Control Panel tray or Menu Panel to the PCU while the PCU is powered up. Damage to the equipment can result.

Kayenne M/E and Local Aux Stripe Connections

It is recommended that the PCU numbered ports be connected to Control Panel Stripes in ascending M/E order, followed by the Local Aux Stripe. PCU port connections can be re-

mapped, but this order matches the default configuration. The table below shows the connections for various Kayenne Control Panel models used in a single suite.

PCU Port to Control Panel Stripe Connections, Single Suite

Control Panel Model	PCU Port	Panel Stripe
4-M/E with Local Aux	1	M/E 1 (top Stripe)
	2	M/E 2 (second Stripe)
	3	M/E 3 (third Stripe)
	4	M/E 4 (bottom Stripe)
	5	Local Aux Stripe
3-M/E with Local Aux	1	M/E 1 (top Stripe)
	2	M/E 2 (second Stripe)
	3	M/E 3 (bottom Stripe)
	4	Local Aux Stripe
2-M/E with Local Aux	1	M/E 1 (top Stripe)
	2	M/E 2 (bottom Stripe)
	3	Local Aux Stripe
1-M/E (without Local Aux)	2	Master E-MEM, MFM (top tray)
	1	M/E (bottom tray)

Kayenne Satellite Panel Cabling

PCU Cabling

CAUTION: Do not connect or disconnect multi-pin PCU cables while the PCU is powered up. Damage to the equipment can result.

Each Satellite Panel has a standard multi-pin cable for connection to the PCU. Modules independent of a particular Stripe (for example Device Control or Master E-MEM modules) can use any available PCU connector.

Modules to be associated with a particular Stripe (like a Transition Module) must be connected to the next higher PCU port for that Stripe. For example, if you wish to use a Transition Module with M/E 4 that uses PCU Port 4, plug the Satellite Panel into PCU Port 5, and move the Local Aux Stripe connector (if used) to PCU Port 6.

Internal Cabling

CAUTION: The RJ-45 connectors inside the Satellite Panel trays are used for proprietary communications only. Ethernet devices may be damaged if plugged into these connectors.

The RJ-45 connectors inside the Satellite Panel trays are used for proprietary communications only. Ethernet devices may be damaged if plugged into these connectors.

The Single Module Satellite Panel has internal module cabling the same as the other Stripes. Simply plug the module into a port using the provided cable.

The Double Module Satellite Panel has a similar internal cabling arrangement, but one cable passes through a hole to the other tray.

Kayenne Touch Screen Menu Panels (Used with PCU)

Connect a single or primary Menu Panel to the PCU Menu 1 connector, using the supplied custom multi-pin cable. Connect an optional second Menu Panel to the Menu 2 connector. Menu Panels are assigned to suites during system configuration.

System Cabling for the Karrera Control Panel

The Karrera switcher system uses Ethernet, serial, DVI, and USB connections for system communications.

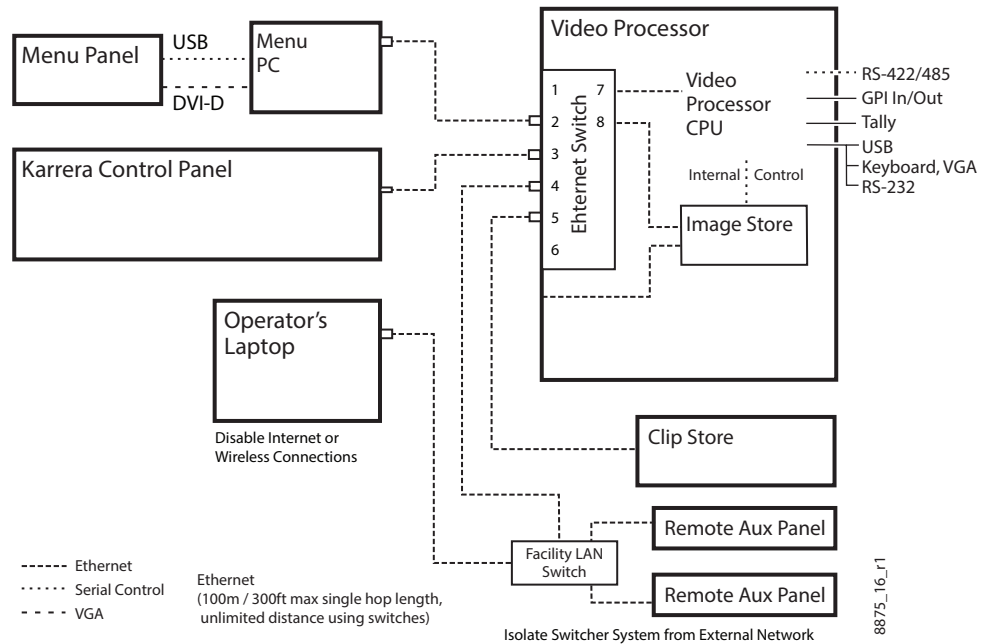

Karrera GV K-Frame XP System Communications Overview

CAUTION: The facility network used for your GV K-Frame XP system (and other video production equipment) should be kept separate from any external network, to prevent network traffic from adversely affecting system operation.

Karrera Suites and Control Surfaces

The GV K-Frame XP Control Panel system flexibility allows you to locate control surfaces in physically separate locations. Two dedicated, customer supplied Ethernet switches may be required when multiple suites are being used.

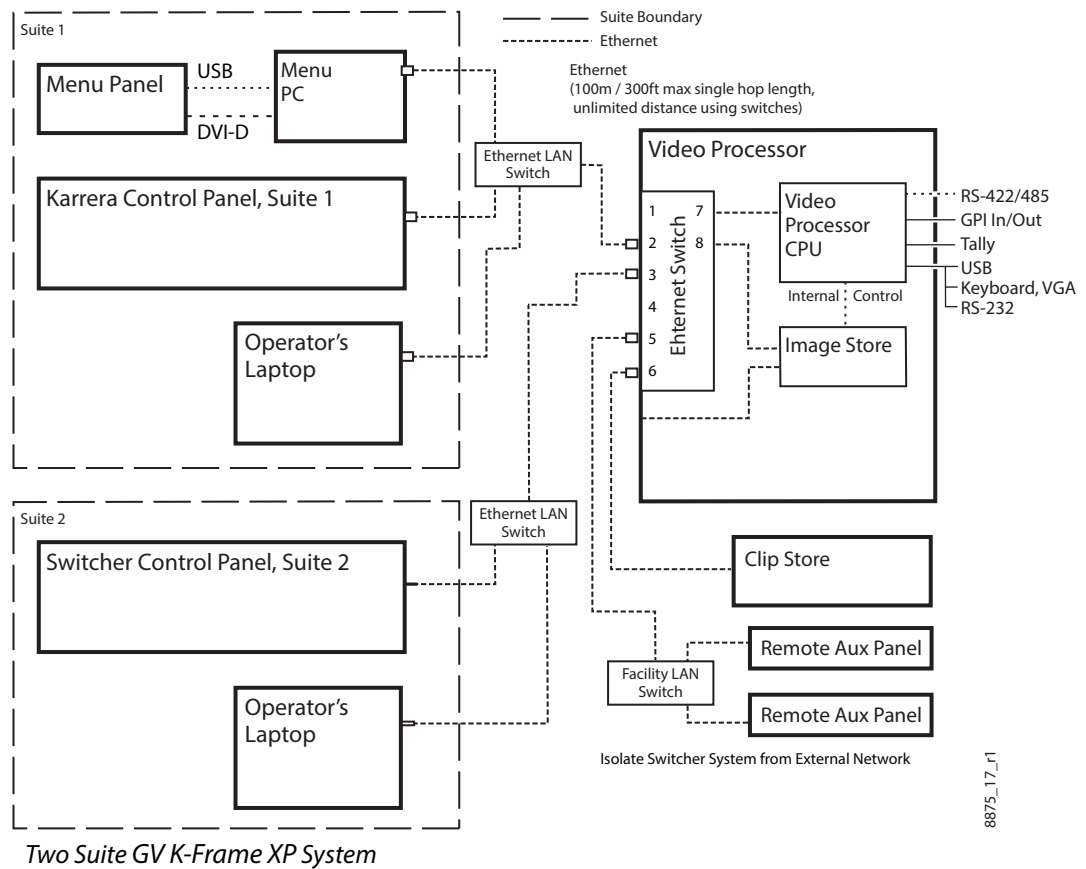

Karrera Control Panel Network Cabling

Ethernet, USB, and DVI-D connections are used between the GV K-Frame XP Video Processor, Control Panel, and optional Menu Panel PC.

Optional Touch Screen Menu Panel Cabling

Five connections are required for the Touch Screen Menu option. If the articulated arm is used, some of these cables can be routed through channels in the arm that have covers that snap into place.

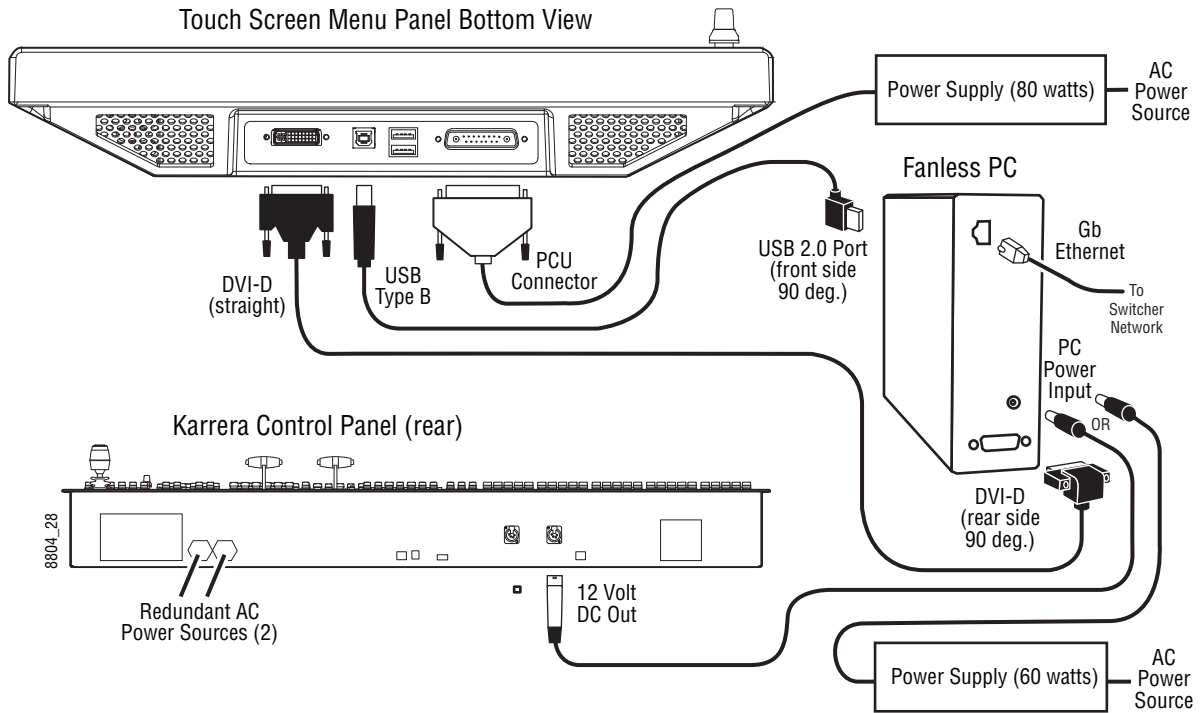

Menu Panel Cabling

CAUTION: Connect the USB port on the front of the Fanless PC (next to the firewire 1394 port) to the Menu Panel. The default PC settings enable knob control by mapping Com 3 to that front USB port.

Optional Karrera Local Aux Panel Cabling

The Karrera GV K-Frame XP Local Aux Panel is powered from the Control Panel, using a 4-pin XLR cable. System control is provided using a RJ-45 connecting cable, which uses a proprietary communications protocol (not Ethernet).

System Cabling
Optional Karrera Local Aux Panel Cabling

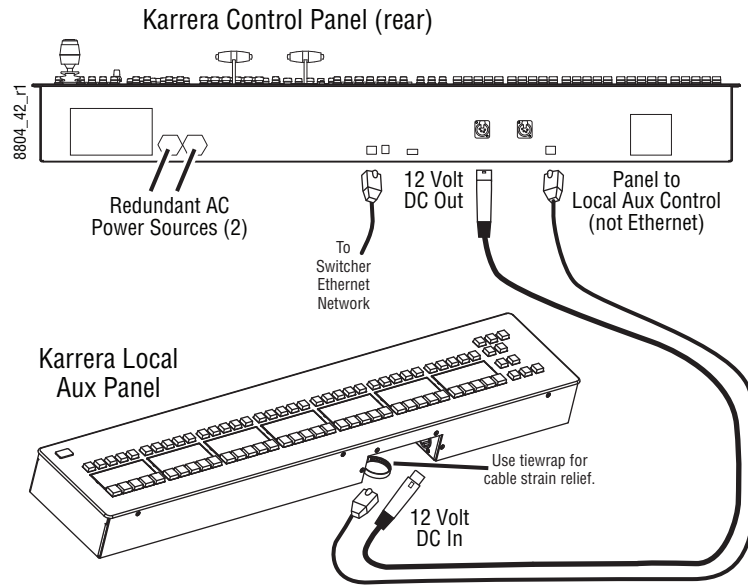

Local Aux Panel Cabling

System Cabling for the GV Korona Control Panel

The GV Korona GV K-Frame XP system uses Ethernet connections for communications. The Video Processor has a built-in Ethernet switch. Tally outputs and GPI I/O (General Purpose Interface Input/Output) control are also available on the Frame.

CAUTION: The facility network used for your GV K-Frame XP system (and other video production equipment) should be kept separate from any external network, to prevent network traffic from adversely affecting system operation.

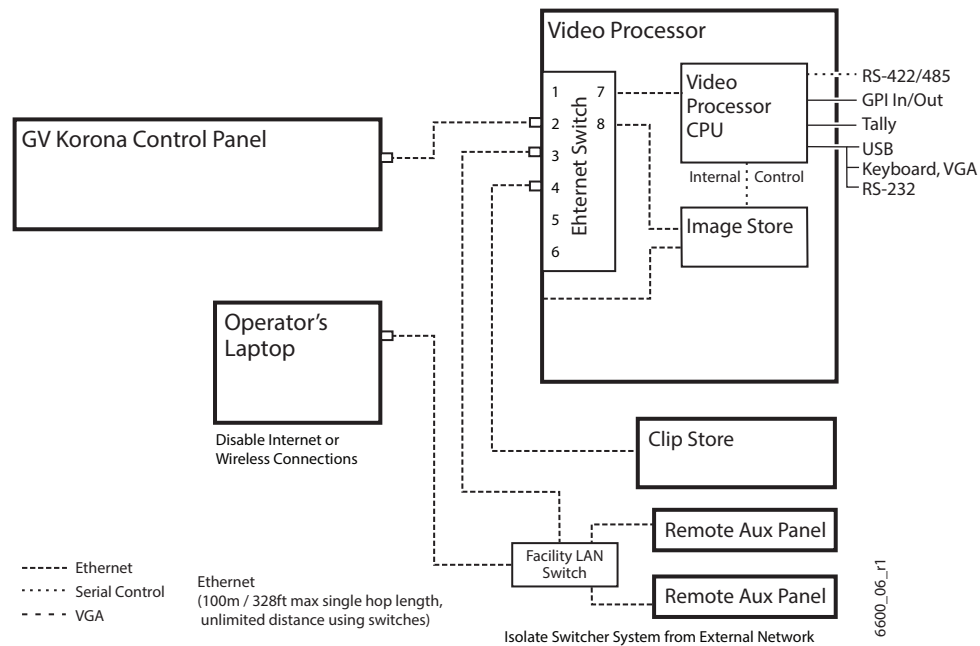

GV Korona GV K-Frame XP System Communications Overview

GV Korona Suites and Control Surfaces

The GV K-Frame XP Control Panel system flexibility allows you to locate control surfaces in physically separate locations. Two dedicated, customer supplied Ethernet switches may be required when multiple suites are being used.

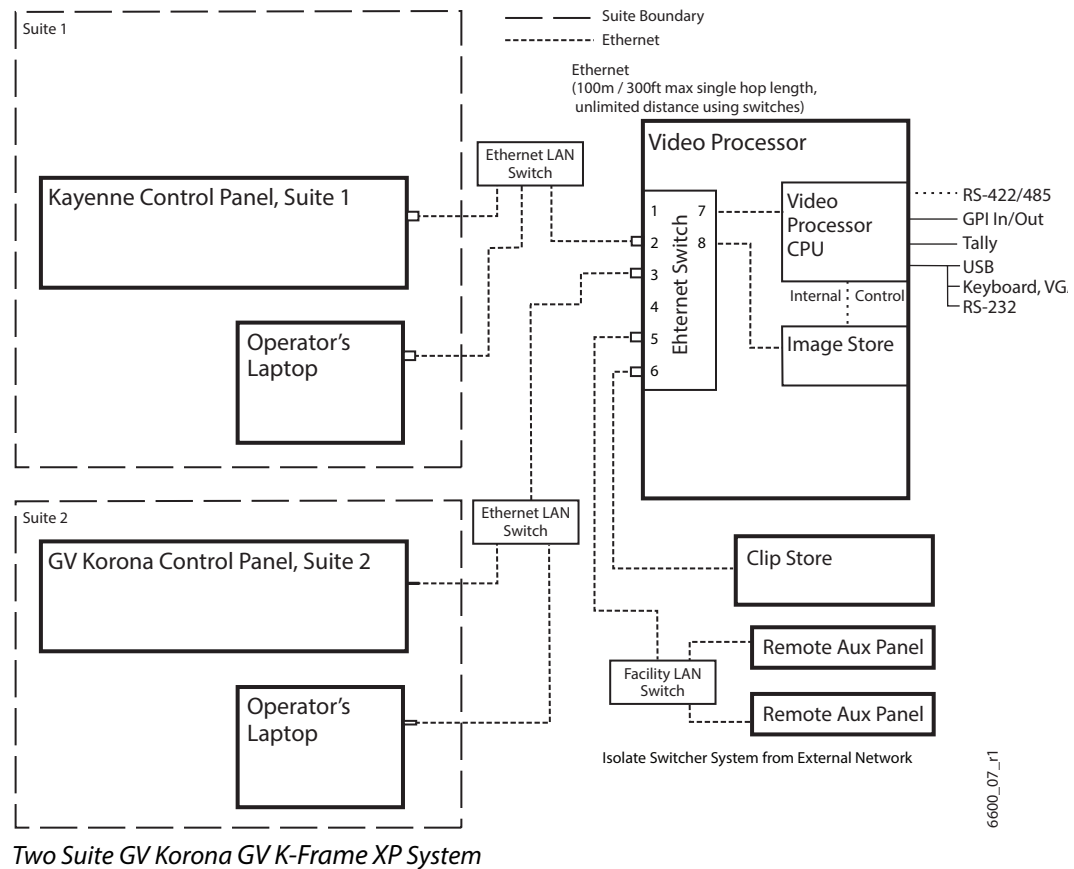

GV K-Frame XP Video Cabling

All GV K-Frame XP system video inputs and outputs are configurable. For cabling configuration flexibility, each external primary input can be mapped to any control panel source select button, as can each internal video system source. Any GV K-Frame XP system video signal, such as M/E program, preview, clean feed, or PGM/PST, can be mapped to any output bus to be sent to any output connector, or an output bus can act as an auxiliary bus.

10GigE IP I/O Fiber Optic Cabling

Grass Valley recommends using OM3 (maximum of 300 meters) or OM4 (maximum of 400 meters) Multi-mode Fiber Optic cabling with the 10GBASE-SR Modules provided with the 10GE IP/IO boards.

SDI Inputs

Non-looping video inputs on the back of the Video Processor Frame accept a 270 MHz, 1.485 Gb, or 3 Gb serial digital video signal.

SDI Outputs

Identical signals are present on each of the paired output connectors on the back of the Video Processor Frame. All of the outputs carry the same video format, as determined by the standard selected and by the reference signals connected.

Reference Input

The GV K-Frame XP Video Processor has referencing that can lock to any digital input video signal or one analog looping reference input. Each can be used with any SD/HD/3G/4K standard.

Note: The Frame Operating Mode does not automatically set to the reference input and does not follow the input sync rate. The Frame Operating Mode is set in the Eng Setup, Video Settings menu.

For the analog looping reference input, 75-ohm termination of the looping input can be used either directly, on the adjacent connector, or at the end of a daisy chain looping to other equipment.

Input Sync Rates will show 'Locked' in the Frame Status pane of the Eng Setup, Video Settings menu when the Frame Operating Mode matches an evenly divisible input reference frequency. For example, if your reference is NTSC color black (frame rate 29.97Hz, field rate 59.94Hz) you can select any Frame Operating Mode that has a vertical rate of 29.97Hz or 59.94Hz.

Supported Media Port Frame Rates

SD

- 720p (1440)x480i 29.97 Hz
- 720p (1440)x576i 25 Hz

HD

- 1280x720p 50/59.94/60 Hz
- 1920x1080i 25/29.97/30 Hz

Note: HDCP is *not* supported.

ClipStore Cabling

The GV K-Frame XP system uses an Ethernet connection for communications with ClipStore. Ethernet cables are connected from the Frame, either directly or through a dedicated Ethernet switch, to the bottom left (of the four) 100BT/1000BT Ethernet ports on the Summit/Solo backplane. *Refer to the K2 Summit/Solo manuals included with the your K2 system.*

ClipStore Video Cabling

The ClipStore channels on the server backplane are labeled C1-C4 (Channel 1 through Channel 4 on the Summit) from left to right. The Solo backplane is not labeled, Channel 1 is on the left and Channel 2 is on the right when facing the backplane.

ClipStore requires SDI connections for both video and key— two connections In/Out per channel for recording and playback. For playback only, two SDI connections to Out 1 and Out 2 are all that is required per channel.

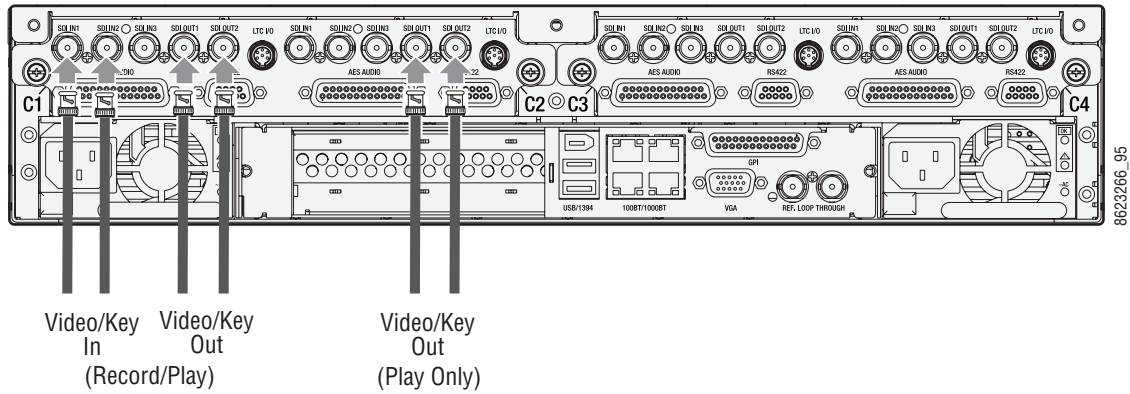

ClipStore Backplane Connections

The ClipStore server (4-channel Summit/2-Channel Solo) can be connected directly to the frame. It is also possible to connect to the ClipStore directly from a router and not use any switcher outputs.

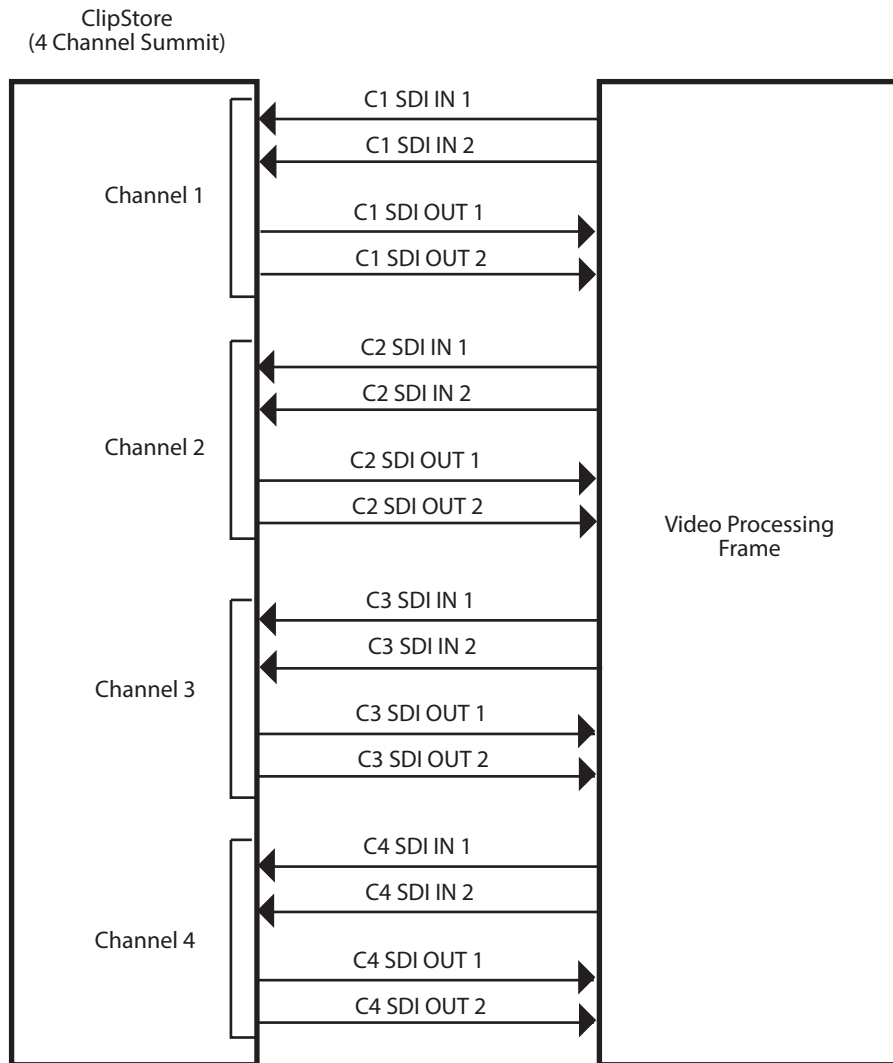

8623-266_9411

ClipStore Direct Connection

Odd numbered outputs are used for fill and even are used for cut. The first output assigned to a ClipStore channel must be an odd numbered output.

Also, DAs (Distribution Amplifiers) can be used to distribute Frame Aux Bus output. The example shows DAs being used for both the Video and Key Aux Bus outputs from the frame.

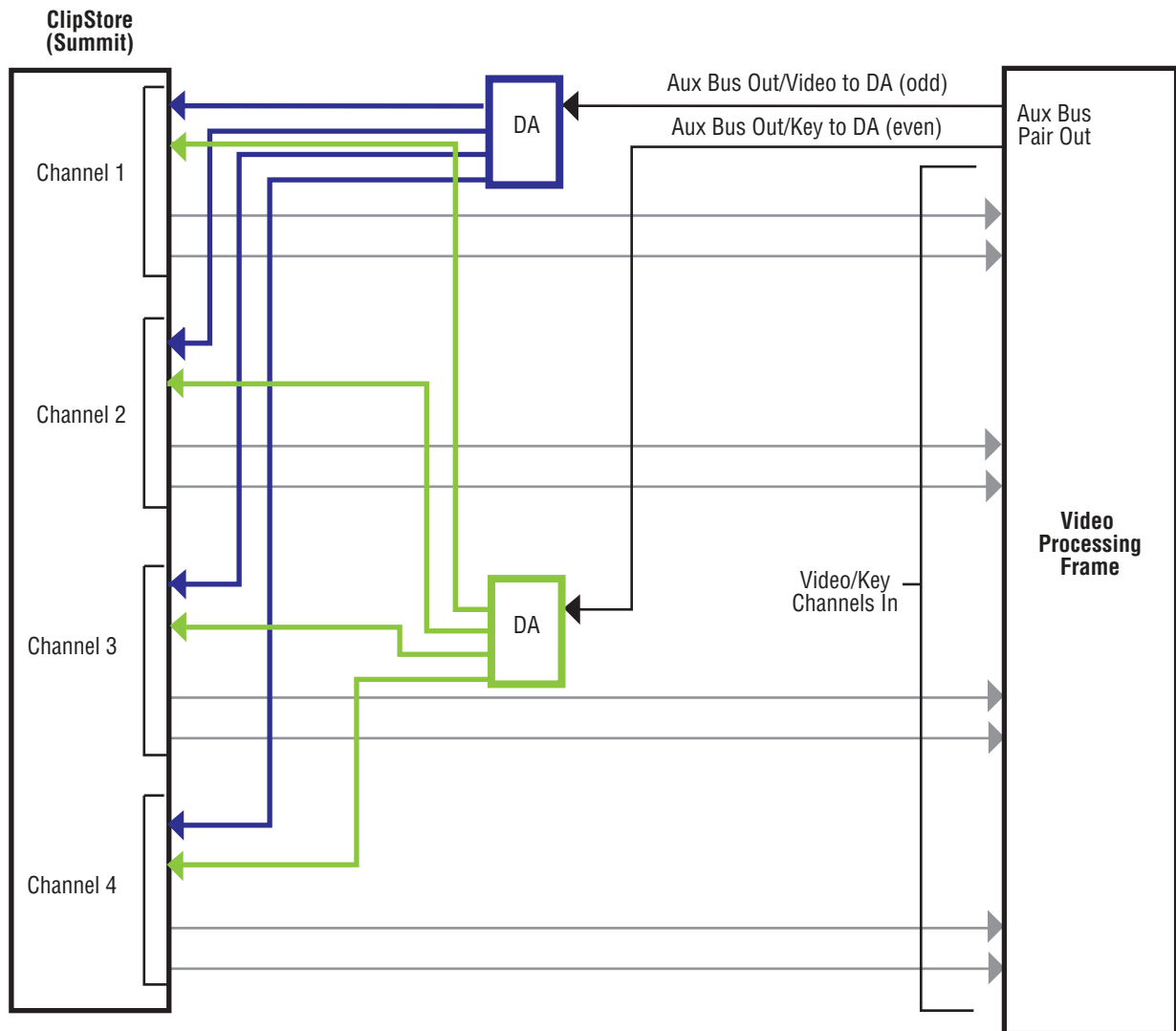

ClipStore Connection Using Distribution Amplifiers

GV K-Frame XP Video Processor Frame GPI/Relay Tally Interface

The GPI (General Purpose Interface) and relay tally interface provides a means to transfer commands to and from the switcher to external devices. A one wire per function parallel hardware relay mechanism is used. The nominal contact rating specification for each relay is 1A, 60 V.

GPI and Relay Tally Connections

Each Video Input/Output module has a 37 pin female sub-miniature D connector on the rear of the chassis, available for GPI and relay tally. Each connector has 4 GPI Inputs, 4 GPI Outputs, and 16 Relay Tally Outputs. Relays are in groups of four with a common ground. The output relays are the same hardware but the GPI is being driven by the GPI output

software and the relay tally is driven by the Relay Tally system software. Relay tally connections can be used to trigger GPIs on external devices.

GPI Inputs

The purpose of the GPI In pins is to provide a stimulus from the external devices to the switcher. A simple connection of two pins activates the corresponding input. An external relay contact or an open-collector output can be employed.

CAUTION: When connecting to an open-collector output, there is no ground potential isolation between the Video Processor Frame and controlling devices.

Since the circuit ground is led out of the device, cabling should be shielded for this kind of control. Non-shielded cables may cause EMC and/or ESD problems.

To activate a GPI In you must provide switch closure between a particular GPI In pin and its common (1 or 20). Pins 1 and 20 of each connector are connected to ground. For applications that span across more than one connector, only one ground (common) connection is required.

The following diagram has the GV K-Frame X GPI inputs on the left.

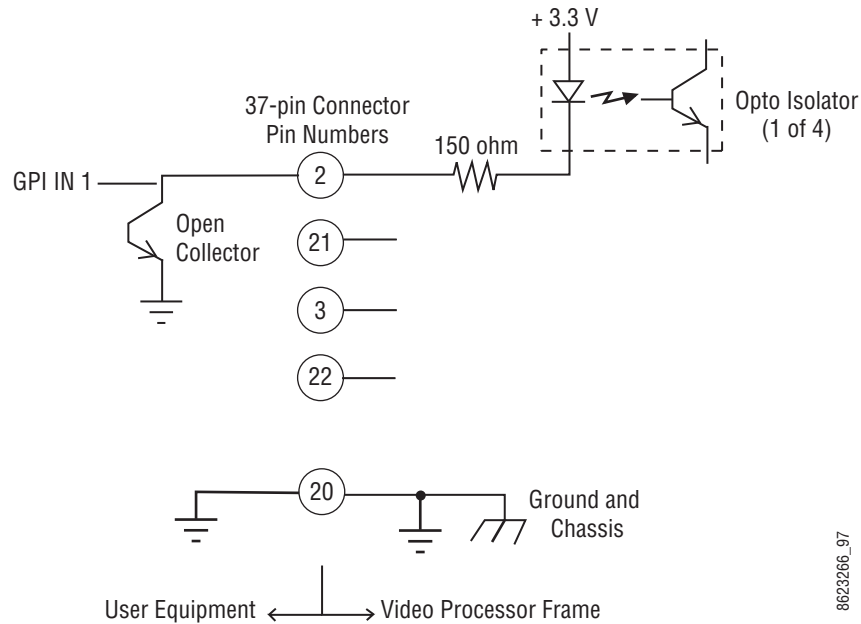

GPI Input Connections (Typical 1 of 4 Connections)

Relay Tally/GPI Outputs

Relay Tally and GPI Outputs are arranged in groups of four. Each group has its own common connection. These commons can all be tied together, forming one common bus for all the outputs. Alternatively, multiple smaller commons can be constructed to interface with systems that need isolated common connections. This common or isolated bus scheme can

extend across multiple connectors. For example, a situation may require two isolated common buses, half of the commons form the first common bus and the other half form the second common bus.

The first four outputs have the common bus tied to +12 Volts. This drives the relay tally lamp system. The last outputs have the common bus tied to ground; this drives a logic system. All relays can be used to drive logic or control external circuitry.

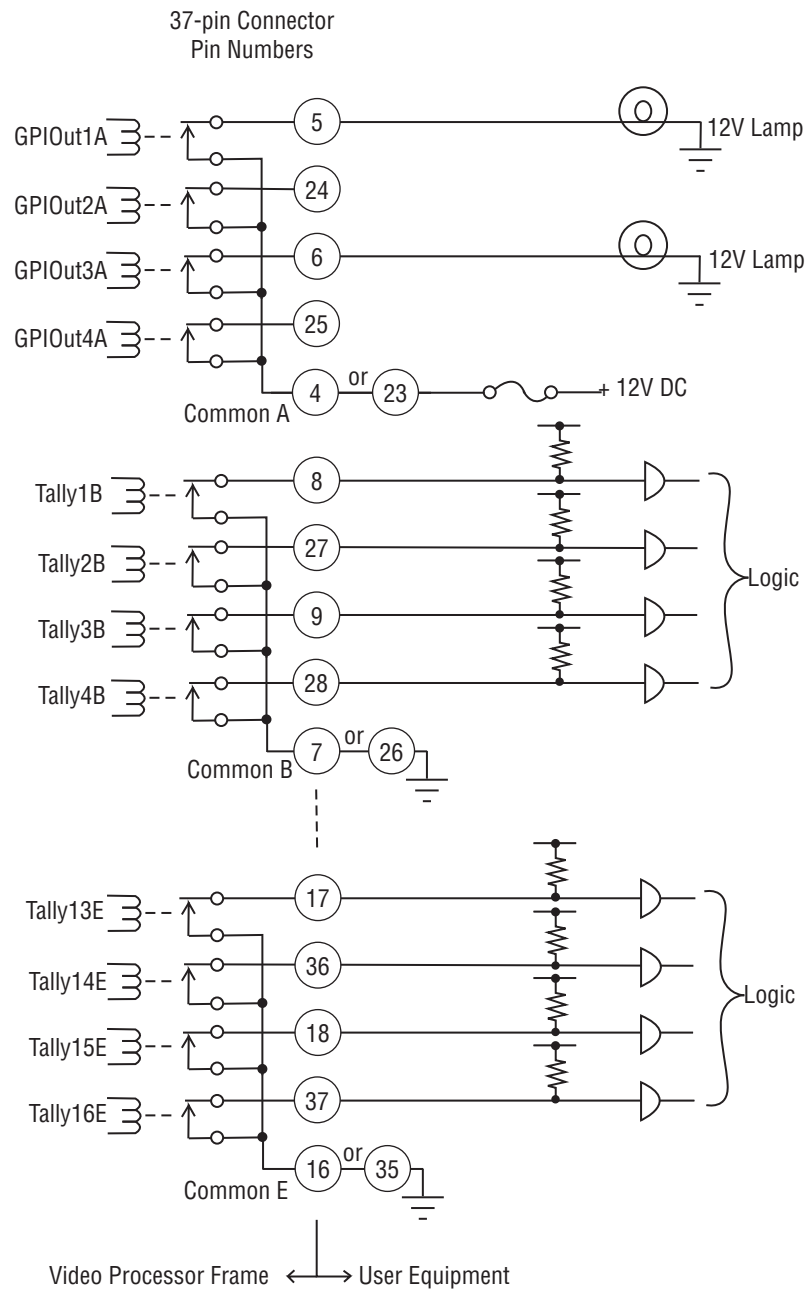

Relay Tally and GPI Output Connection Example

Although the diagram shows mechanical relays, the actual outputs are implemented with solid state relays. The solid state relays are bidirectional; either polarity voltage can be applied. If the switcher GPI/Relay Tally outputs are used to drive downstream DC relays, be sure to install diodes across the relay coils to clamp inductive spikes. Shielded cable is recommended for the connection from the switcher to the user Relay Tally system.

Relay Tally and GPI Output Specifications

Maximum current for any one output	1 amp AC/DC
Maximum current for any one common	2 amp AC/DC
Maximum off (open circuit) voltage between output and common	60 Volts peak
Maximum voltage between any point and ground (chassis)	60 Volts peak

GPI In, GPI Out, Relay Tally Pin Assignments

Each GV K-Frame X Input/Output Module has a 37 pin connector for GPI and Relay Tally. The connectors are arranged in left to right order on the rear of the Frame.

Input/Output Module Connectors

Module Number	Signals	Module Number	Standard 13RU Frame
1	GPI In 1-4	6	GPI In 21-24
	GPI Out 1-4		GPI Out 21-24
	Relay Tally 1-16		Relay Tally 81-96
2	GPI In 5-8	7	GPI In 25-28
	GPI Out 5-8		GPI Out 25-28
	Relay Tally 17-32		Relay Tally 97-112
3	GPI In 9-12	8	GPI In 29-32
	GPI Out 9-12		GPI Out 29-32
	Relay Tally 33-48		Relay Tally 113-128
4	GPI In 13-16	9	GPI In 33-36
	GPI Out 13-16		GPI Out 33-36
	Relay Tally 49-64		Relay Tally 129-144
5	GPI In 17-20	10	GPI In 37-40
	GPI Out 17-20		GPI Out 37-40
	Relay Tally 65-80		Relay Tally 145-160

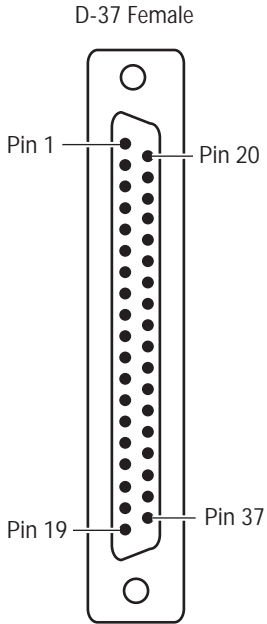

Socket Pinout

GPI Signals

GPI In, Tally, GPI Out Signals (first five boards from left to right)

Ribbon Cable	37-Pin D-Sub	1	2	3	4	5
1	1	GPIInCom	GPIInCom	GPIInCom	GPIInCom	GPIInCom
2	20	GPIInCom	GPIInCom	GPIInCom	GPIInCom	GPIInCom
3	2	GPIIn1	GPIIn5	GPIIn9	GPIIn13	GPIIn17
4	21	GPIIn2	GPIIn6	GPIIn10	GPIIn14	GPIIn18
5	3	GPIIn3	GPIIn7	GPIIn11	GPIIn15	GPIIn19
6	22	GPIIn4	GPIIn8	GPIIn12	GPIIn16	GPIIn20
7	4	GPIOutCom	GPIOutCom	GPIOutCom	GPIOutCom	GPIOutCom
8	23	GPIOutCom	GPIOutCom	GPIOutCom	GPIOutCom	GPIOutCom
9	5	GPIOut1	GPIOut5	GPIOut9	GPIOut13	GPIOut17
10	24	GPIOut2	GPIOut6	GPIOut10	GPIOut14	GPIOut18
11	6	GPIOut3	GPIOut7	GPIOut11	GPIOut15	GPIOut19
12	25	GPIOut4	GPIOut8	GPIOut12	GPIOut16	GPIOut20
13	7	TallyComA	TallyComE	TallyComI	TallyComM	TallyComQ
14	26	TallyComA	TallyComE	TallyComI	TallyComM	TallyComQ
15	8	Tally1A	Tally17E	Tally33I	Tally49M	Tally65Q
16	27	Tally2A	Tally18E	Tally34I	Tally50MK	Tally66Q
17	9	Tally3A	Tally19E	Tally35I	Tally51M	Tally67Q
18	28	Tally4A	Tally20E	Tally36I	Tally52M	Tally68Q
19	10	TallyComB	TallyComF	TallyComJ	TallyComN	TallyComR
20	29	TallyComB	TallyComF	TallyComJ	TallyComN	TallyComR
21	11	Tally5B	Tally21F	Tally37J	Tally53N	Tally69R
22	30	Tally6B	Tally22F	Tally38J	Tally54N	Tally70R
23	12	Tally7B	Tally23F	Tally39J	Tally55N	Tally71R
24	31	Tally8B	Tally24F	Tally40J	Tally56N	Tally72R
25	13	TallyComC	TallyComG	TallyComK	TallyComO	TallyComS
26	32	TallyComC	TallyComG	TallyComK	TallyComO	TallyComS
27	14	Tally9C	Tally25G	Tally41K	Tally57O	Tally73S
28	33	Tally10C	Tally26G	Tally42K	Tally58O	Tally74S
29	15	Tally11C	Tally27G	Tally43K	Tally59O	Tally75S
30	34	Tally12C	Tally28G	Tally44K	Tally60	Tally76S
31	16	TallyComD	TallyComH	TallyComL	TallyComP	TallyComT
32	35	TallyComD	TallyComH	TallyComL	TallyComP	TallyComT
33	17	Tally13D	Tally29H	Tally45L	Tally61P	Tally77T
34	36	Tally14D	Tally30H	Tally46L	Tally62P	Tally78T

System Cabling

GPI In, GPI Out, Relay Tally Pin Assignments

GPI In, Tally, GPI Out Signals (first five boards from left to right)

Ribbon Cable	37-Pin D-Sub	1	2	3	4	5
35	18	Tally15D	Tally31H	Tally47L	Tally63P	Tally79T
36	37	Tally16D	Tally32H	Tally48L	Tally64P	Tally80T
37	19	Reserved	Reserved	Reserved	Reserved	Reserved

GPI In, Tally, GPI Out Signals (second five boards from left to right)

Ribbon Cable	37-Pin D-Sub	6	7	8	9	10
1	1	GPIInCom	GPIInCom	GPIInCom	GPIInCom	GPIInCom
2	20	GPIInCom	GPIInCom	GPIInCom	GPIInCom	GPIInCom
3	2	GPIIn21	GPIIn25	GPIIn29	GPIIn33	GPIIn37
4	21	GPIIn22	GPIIn26	GPIIn30	GPIIn34	GPIIn38
5	3	GPIIn23	GPIIn27	GPIIn31	GPIIn35	GPIIn39
6	22	GPIIn24	GPIIn28	GPIIn32	GPIIn36	GPIIn40
7	4	GPIOutCom	GPIOutCom	GPIOutCom	GPIOutCom	GPIOutCom
8	23	GPIOutCom	GPIOutCom	GPIOutCom	GPIOutCom	GPIOutCom
9	5	GPIOut21	GPIOut25	GPIOut29	GPIOut33	GPIOut37
10	24	GPIOut22	GPIOut26	GPIOut30	GPIOut34	GPIOut38
11	6	GPIOut23	GPIOut27	GPIOut31	GPIOut35	GPIOut39
12	25	GPIOut24	GPIOut28	GPIOut32	GPIOut36	GPIOut40
13	7	TallyComU	TallyComY	TallyComAC	TallyComAG	TallyComAK
14	26	TallyComU	TallyComY	TallyComAC	TallyComAG	TallyComAK
15	8	Tally81U	Tally97Y	Tally113AC	Tally129AG	Tally145AK
16	27	Tally82U	Tally98Y	Tally114AC	Tally130AG	Tally146AK
17	9	Tally83U	Tally99Y	Tally115AC	Tally131AG	Tally147AK
18	28	Tally84U	Tally100Y	Tally116AC	Tally132AG	Tally148AK
19	10	TallyComV	TallyComZ	TallyComAD	TallyComAH	TallyComAL
20	29	TallyComV	TallyComZ	TallyComAD	TallyComAH	TallyComAL
21	11	Tally85V	Tally101Z	Tally117AD	Tally133AH	Tally149AL
22	30	Tally86V	Tally102Z	Tally118AD	Tally134AH	Tally150AL
23	12	Tally87V	Tally103Z	Tally119AD	Tally135AH	Tally151AL
24	31	Tally88V	Tally104Z	Tally120AD	Tally136AH	Tally152AL
25	13	TallyComW	TallyComAA	TallyComAE	TallyComAI	TallyComAM
26	32	TallyComW	TallyComAA	TallyComAE	TallyComAI	TallyComAM
27	14	Tally89W	Tally105AA	Tally121AE	Tally137AI	Tally153AM
28	33	Tally90W	Tally106AA	Tally122AE	Tally138AI	Tally154AM
29	15	Tally91W	Tally107AA	Tally123AE	Tally139AI	Tally155AM

GPI In, Tally, GPI Out Signals (second five boards from left to right)

Ribbon Cable	37-Pin D-Sub	6	7	8	9	10	
30		34	Tally92W	Tally108AA	Tally124AE	Tally1 40AI	Tally156AM
31	16		TallyComX	TallyComAB	TallyComAF	TallyComAJ	TallyComAN
32		35	TallyComX	TallyComAB	TallyComAF	TallyComAJ	TallyComAN
33	17		Tally93X	Tally109AB	Tally125AF	Tally141AJ	Tally157AN
34		36	Tally94X	Tally110AB	Tally126AF	Tally142AJ	Tally158AN
35	18		Tally95X	Tally111AB	Tally127AF	Tally1 43AJ	Tally159AN
36		37	Tally96X	Tally112AB	Tally128AF	Tally144AJ	Tally150AN
37	19		Reserved	Reserved	Reserved	Reserved	Reserved

RS-422/485 Port Pin Assignments

Eight RS-422/485 ports are available on the rear of the GV K-Frame XP Video Processor, and can be used to control various devices, or for switcher control by an external controller.

Note: The Frame serial port pinout is automatically configured based on assignment. The Frame is the bus controller when controlling external devices and PBus. The Frame is a tributary when controlled by an editor.

RS-422/485 Pinouts

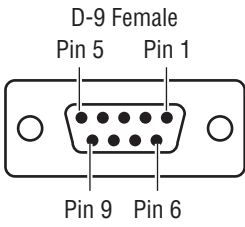
Socket	Pin	Bus Controller	Tributary
 <p>D-9 Female Pin 5 Pin 1 Pin 9 Pin 6</p>	1	Chassis Ground	Chassis Ground
	2	RxA (-)	TxA (-)
	3	TxB (+)	RxB (+)
	4	Signal Ground	Signal Ground
	5	Not used	Not used
	6	Signal Ground	Signal Ground
	7	RxB (+)	TxB (+)
	8	TxA (-)	RxA (-)
	9	Chassis Ground	Chassis Ground

RS-232 Port Pin Assignments

RS-232 serial ports are located on each processor board (Video Processor, Panel Processor, Menu PC), available for maintenance and diagnostics. Standard VGA and keyboard ports, present on all processor boards, are also available for maintenance.

RS-232 Pinouts

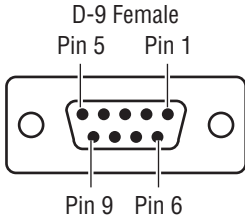
Socket	Pin	Signal
	1	Chassis Ground
	2	Transmit Data
	3	Receive Data
	4	Not used
	5	Signal Ground
	6	Not used
	7	Clear to Send
	8	Request to Send
	9	Not used

\Remote Aux Panels

For configuration, see [Install Remote Aux Panel Software](#), on page 146.

GV-RAP-100 and GV-RAP-200 Remote Aux Panels

The GV-RAP-100 and GV-RAP-200 have the same rear panel layout.



Remote Aux Panel Power Supply AC Requirements

The GV-RAP-100 and GV-RAP-200 external Power Supply is power factor corrected and automatically accommodates low line (120V nominal) or high line (240V nominal). The power supply has a rating of 100 – 240 volts, although it is designed and tested for a range of 90 to 264 volts to accommodate under and over voltage conditions. GV-RAP Aux panels are supplied with one power module. An optional second power module can be added for redundancy (n+1).

Supplied Power Cables

The GV-RAP-100 and GV-RAP-200 external Power Supply has IEC C14 sockets. Cables provided are matched to the destination country's standard. For example, in the USA C14 to NEMA 5-20P cables are provided.

Ethernet Requirements

Cable type: 10BaseT, 100BaseT, 1000BaseT compatible Category 5 cable, 8 conductor twisted pair.

The system will work at lower ratings with reduced performance. 1000BaseT components are highly recommended.

RAP 100/200 GPI I/O Port Pin Assignments

Pin assignments are for both the GPI I/O 1-8 and GPI I/O 9-16 D-25 Female connector ports.

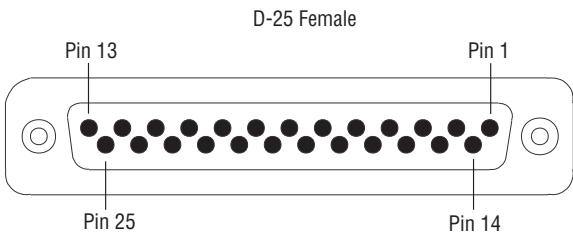
Socket	Pin	Signal
	1	Tally Out 15
	2	Tally Out 13
	3	Tally Out Common for 12 to 15
	4	Tally Out 11
	5	Tally Out 9
	6	Tally Out Common for 8 to 11
	7	GND
	8	Tally In 14
	9	Tally In 13
	10	GND
	11	Tally In 10
	12	Tally In 9
	13	GND
	14	Tally Out 14
	15	Tally Out 12
	16	GND
	17	Tally Out 10
	18	Tally Out 8
	19	GND
	20	Tally In 15
	21	GND
	22	Tally In 12
	23	Tally In 11
	24	GND
	25	Tally In 8

A Specifications

GV K-Frame XP Video Processor Specifications

GV K-Frame XP—Number of VPEs, Inputs, and Outputs

Frame	M/Es and VPEs	Inputs	Outputs	GPI Inputs	GPI/Tally Outputs
Compact	1 to 6 VPEs	16 to 80 SDI/IP, 0-2Media Ports 0-16 MatchDef	8-40 SDI/IP, 0-8SetDef	4 per, up to 4 modules	4 GPI/24 Relay Tally, up to 4 modules

GV K-Frame XP Video Standards (Hz)

4K UHD-SDI Modes

2160p 50/59.94/60	SMPTE 2082-10
2160p 23.96/24/25/29.97/30	SMPTE 2081-10
4K 2SI Quad Link 50/59.94/60	SMPTE 425-5
4K SDQS Quad Link 50/59.94/60	SMPTE 425-5

3G Modes

1080p50/59.94/60, Level A and Level B	SMPTE 424M
---------------------------------------	------------

HD Modes

1080i 29.97/30/25	SMPTE 274M
1080psf 23.976/24/25/29.97/30	SMPTE RP211
1080p 23.976/24/25/29.97/30	SMPTE 274M
720p 50/59.94/60	SMPTE 296

GV K-Frame XP Interfaces

Video	<ul style="list-style-type: none"> • ST 2110-20 • ST 2110-21 => Receiver Type N (gapped only), Sender Type N • ST 2022-6 • 4K UHD TICO over ST 2022-6
Audio	ST 2110-30
Ancillary Data	ST 2110-40
Redundancy	ST 2022-7 (Proposed Class D)
Timing	ST 2110-10

GV K-Frame XP Serial Digital Video Inputs

Format	<ul style="list-style-type: none"> • ITU-R656, SMPTE 259M, 270 Mbit/s • SMPTE 292M, 1.5 Gbit/s • SMPTE 424M, 3 Gbit/s • SMPTE 2081 6 Gbit/s • SMPTE 2082 12 Gbit/s
Return loss	<ul style="list-style-type: none"> • >15db, 5.0 MHz to 1.5 GHz • >10 db, 1.5 GHz to 3.0 GHz • >7db, 3.0 GHz to 6.0 GHz • >4db, 6.0 GHz to 12.0 GHz
Type of Connector	75 ohm BNC (SMPTE 259M)
Nominal Amplitude	800mv peak-to-peak terminated
Input Impedance	75 ohm
Maximum cable length (Using Belden 1694A type cable)	<ul style="list-style-type: none"> • SD Video 350 meters (1148 ft) • HD Video 200 meters (656 ft) • 3G Video 140 meters (459 ft) • 12G Video 60 meters (197 ft)

GV K-Frame XP Serial Digital Video Outputs

Format	<ul style="list-style-type: none"> • ITU-R656, SMPTE 259M, 270 Mbit/s. • SMPTE 292M, 1.5 Gbit/s • SMPTE 424M, 3 Gbit/s • SMPTE 2081 6 Gbit/s • SMPTE 2082 12 Gbit/s
Return loss	<ul style="list-style-type: none"> • >15db, 5.0 MHz to 1.5 GHz • >10 db, 1.5 GHz to 3.0 GHz • >7db, 3.0 GHz to 6.0 GHz • >4db, 6.0 GHz to 12.0 GHz
Ancillary Data/ Embedded audio	Blanked or passed (user selectable)
EDH	Blanked
Type of Connector	75 ohm BNC (SMPTE 259M)
Nominal Amplitude	800 mv peak-to-peak across 75 ohm +/- 10%
Rise & Fall Times (75 ohm termination between 20% and 80%)	<ul style="list-style-type: none"> • SD: 400 to 1400 picoseconds amplitude • HD/3G ≤ 135 picoseconds amplitude • 6G: ≤ 80 picoseconds amplitude • 12G: ≤ 45 picoseconds amplitude
Timing Jitter	<ul style="list-style-type: none"> • SD: ≤ 0.2 UI • HD: ≤ 1.0 UI • 3G: ≤ 2.0 UI • 6G: ≤ 2.0 UI • 12G: ≤ 2.0 UI
Alignment jitter	<ul style="list-style-type: none"> • SD: ≤ 0.2 UI • HD: ≤ 0.2 UI • 3G: ≤ 0.3 UI • 6G: ≤ 2.0 UI • 12G: ≤ 0.3 UI
Output Impedance	75 ohm
DC Offset	Not to exceed 50mV above or below the average peak-to-peak signal envelope, with 75 ohm termination

GV K-Frame XP Analog Reference Input

Video Standard	Tri-level Sync or Color Black, must be 1/2X (times), 1X, or 2X the Frame Operating Mode vertical rate
Return loss	> 40db, up to 5.0 MHz
Connectors	2 BNC loop-through
Impedance	75 ohm external
Alignment jitter	≤ 2 UI (SD), ≤ 1 UI (HD)
Output Impedance	75 ohm
DC Offset	Not to exceed 50mV above or below the average peak-to-peak signal envelope, with 75 ohm termination

GV K-Frame XP Control Network Connections

Type of connection	10/100/1000 Base T
Protocol	TCP(UDP)/IP: Auto speed detection, Auto crossover cable configuration
Diagnostics	Port mirroring
Cable and connectors	CAT5 UTP, RJ45 connectors
Maximum Cable Length	100m / 300ft

Note: The GV K-Frame XP Video Processor has an internal Ethernet switch with six available external ports. One connection is required for each Control Panel and one is required for each Menu PC. An external Ethernet switch is required to connect more than six devices.

GV K-Frame XP Power

Line voltage	100V-240V AC +/-10% autorange, power factor corrected Automatic line-voltage sensing for 120V and 240V sources
Line frequency	50/60Hz +/- 5%
Maximum power consumption	Compact:1800W
Leakage current	< 2.5 mA (per line cord)

GV K-Frame XP Mechanical

Component	In-rack Depth	Width	Height	Weight (All weights approximate)	Rack Units
Compact	628.4 mm (24.74 in)	482.6 mm (19 in)	354.8 mm (13.97 in)	56.7 kg (125 lbs) (Fully loaded)	8
Power Supply	321.4 mm (12.6 in)	106.7 mm (4.2 in)	40 mm (1.57 in)	11 kg (24lbs) (Two PS modules, each weigh 2.5 kg (5.4 lbs), up to three modules supported)	1

GV K-Frame XP Environmental

Storage temperature	-20 to 70 deg C (-4 to 158 deg F)
Operating temperature	0 to 40 deg C (32 to 104 deg F)
Relative humidity	0-95% (non-condensing)
Electromagnetic environment	E2 (according to EN55103-1, -2)

Kayenne Control Panel Specifications

Kayenne PCU Interconnects

Control Panel - PCU Connections		
Cable and connectors	Custom 7 Pin D style	
Number Required	1 for each Control Panel Stripe, Local Aux Stripe, and Satellite Panel	
Maximum Interconnect Cable Length	15 m / 50 ft (7.5 m / 25 ft cable length also available)	
Cable Weight	15 m / 50 ft	1.3 kg (2.9 lbs)
	7.5 m / 25 ft	0.7 kg (1.6 lbs)
Touch Screen Menu Panel - PCU Connection		
Cable and connectors	Custom 17 Pin D style	
Number Required	1 for each Menu Panel (2 maximum)	
Maximum Interconnect Cable Length	15m / 50ft (7.5m / 25ft cable length also available)	
Cable Weight	15 m / 50 ft	1.6 kg (3.7 lbs)
	7.5 m / 25 ft	0.9 kg (2.0 lbs)

Kayenne Power

PCU (required for Control Panel and Touch Screen Menu Panel Operation)	
Line voltage	100V-240V AC +/-10% autorange, power factor corrected Automatic line-voltage sensing for 120V and 240V sources
Line frequency	50/60Hz +/- 5%
Power consumption	500W maximum
Leakage current	< 2.5 mA

Kayenne Control Panel Mechanical

Component	Depth	Width	Height	Weight (All weights approximate)
Control Panels	Curved Support Structure Orientation			
4-M/E-35, with attached Local Aux Stripe, 15 m Cables	746.3 mm (29.4 in)	1533.7 mm (60.4 in)	559.3 mm (22.0 in)	58 kg (127 lbs)
3-M/E-35, with Local Aux Stripe, 15 m Cables	637.1 mm (25.1 in)	1533.7 mm (60.4 in)	292.3 mm (11.5 in)	45 kg (99lbs)

Kayenne Control Panel Mechanical

Component	Depth	Width	Height	Weight (All weights approximate)
2-M/E-25, with Local Aux Stripe, 15 m Cables	488.4 mm (19.2 in)	1341.7 mm (52.8 in)	242.3 mm (9.5 in)	30 kg (66 lbs)
1-M/E-15, with 15 m Cables, without Local Aux Stripe	356.4 mm (14.0 in)	758.3 mm (29.9 in)	84.3 mm (3.3 in)	15 kg (33 lbs)
Local Aux Stripe	Separately Mounted, Flat Orientation			
Local Aux-35 with 15 m Cable	185.7 mm (7.3 in)	813.7 mm (32.0 in)	84.3 mm (3.3 in)	6 kg (14 lbs)
Local Aux-25 with 15 m Cable	185.7 mm (7.3 in)	621.7 mm (24.5 in)	84.3 mm (3.3 in)	4 kg (9 lbs)
Menu Panel				
Touch Screen with 15 m cable	91.7 mm (3.6 in)	417.85 mm (16.5 in)	270.10 mm (10.6 in)	6 kg (14 lbs)
Menu Panel Support Arm	n/a	n/a	n/a	5 kg (11 lbs)
3-RU Panel Control Unit (PCU)	588.5 mm (23.2 in)	482.6 mm (19 in)	132.6 mm (5.2 in)	16 kg (36 lbs)

Kayenne Environmental

Storage temperature	-20 to 70 deg C (-4 to 158 deg F)
Operating temperature	0 to 40 deg C (32 to 104 deg F)
Relative humidity	0-95% (non-condensing)
Electromagnetic environment	E2 (according to EN55103-1, -2)

Karrera Control Panel Specifications

Karrera Power

Karrera Control Panels	
Line voltage	100V-240V AC +/-10% autorange, power factor corrected Automatic line-voltage sensing for 120V and 240V sources
Line frequency	50/60Hz +/- 5%
Power consumption	200W
Leakage current	< 2.5 mA

Optional Touch Screen Menu System

Touch Screen Menu Panel (power brick provided and required)

Line voltage	100V-240V AC, 1.06 - 0.45A
Line frequency	47-63 Hz
Power consumption	90W maximum
Power brick output	48V, 1.87A

Fanless PC (power brick provided, optionally powered from Karrera panel)

Line voltage	100V-240V AC, 1.7A
Line frequency	50/60Hz
Power consumption	60W
Power brick output	12V, 5.0A

Optional Local Aux Panel (35 or 25, powered from Karrera Panel)

Power input	12V DC, 0.8A maximum
Power consumption	< 10W

Karrera Mechanical

Component	Depth	Width	Height	Weight (All weights approximate)
2-M/E Compact Control Panel	510 mm (20.08 in)	1010 mm (39.8 in)	178 mm (7.0 in)	25 kg (55 lbs)
2-M/E Control Panel	362 mm (14.3 in)	1248.6 mm (49.2 in)	132 mm (5.2 in)	19 kg (41 lbs)
3-M/E Control Panel	510 mm (20.08 in)	1440.6 mm (56.72 in)	178 mm (7.01 in)	28 kg (62 lbs)

Optional Touch Screen Menu System:

Touch Screen Panel	91.7 mm (3.6 in)	417.9 mm (16.5 in)	270.1 mm (10.6 in)	6 kg (14 lbs)
Menu PC (OEM) KRR-MENU-CPU	254 mm (10.0 in)	157 mm (6.2 in)	56 mm (2.2 in)	4 kg (8 lbs)

Specifications

Karrera Control Panel Specifications

Karrera Mechanical

Component	Depth	Width	Height	Weight (All weights approximate)
Menu Panel Support Arm	n/a	n/a	n/a	5 kg (11 lbs)

Optional Local Aux Panel

Local Aux 35	78 mm 3.1 in	800 mm 31.5 in	162 mm 6.4 in	4 kg (9 lbs)
Local Aux 25	78 mm 3.1 in	610 mm 24.0 in	162 mm 6.4 in	3 kg (7 lbs)

Karrera Environmental

Storage temperature	-20 to 70 deg C (-4 to 158 deg F)
Operating temperature	0 to 40 deg C (32 to 104 deg F)
Relative humidity	0-95% (non-condensing)
Electromagnetic environment	E2 (according to EN55103-1, -2)

GV Korona Control Panel Specifications

GV Korona Network Connection

Type of connection	10/100/1000 Base T
Protocol	TCP(UDP)/IP, Auto speed detection
Cable and connectors	CAT5 UTP, RJ45 connectors
Maximum cable length	100m / 300ft

GV Korona Power

Line Voltage	100V-240V AC +/-10% autorange, power factor corrected Automatic line-voltage sensing for 120V and 240V sources
Line frequency	50/60Hz +/- 5%
Power consumption	50W
Leakage current	< 2.5 mA

GV Korona Mechanical

Component	Depth	Width	Height	Weight (All weights approximate)
3-M/E GV Korona Control Panel	736.6mm (29 in)	860.5mm (33.9 in)	287mm (11.3 in)	27.9 Kg (61.4 lbs)
2-M/E GV Korona Control Panel	576.6mm (22.7 in)	764.5mm (30.1 in)	256mm (10.1 in)	17.6 Kg (38.7 lbs)
1-M/E GV Korona Control Panel	419.8mm (16.5 in)	668.5mm (26.3 in)	229.9mm (9.0 in)	12.3 Kg (27.1 lbs)

GV Korona Environmental

Storage temperature	-20 to 70 deg C (-4 to 158 deg F)
Operating temperature	0-95% (non-condensing)
Relative humidity	0 to 40 deg C (32 to 104 deg F)
Electromagnetic environment	E2 (according to EN55103-1, -2)

B Regulatory Notices

Certifications and Compliances

FCC Emission Control

This equipment has been tested and found to comply with the limits for a Class A digital device, pursuant to Part 15 of the FCC Rules. These limits are designed to provide reasonable protection against harmful interference when the equipment is operated in a commercial environment. This equipment generates, uses, and can radiate radio frequency energy and, if not installed and used in accordance with the instruction manual, may cause harmful interference to radio communications. Operation of this equipment in a residential area is likely to cause harmful interference in which case the user will be required to correct the interference at his own expense. Changes or modifications not expressly approved by Grass Valley Group can affect emission compliance and could void the user's authority to operate this equipment.

Canadian EMC Notice of Compliance

This digital apparatus does not exceed the Class A limits for radio noise emissions from digital apparatus set out in the Radio Interference Regulations of the Canadian Department of Communications.

Le présent appareil numérique n'émet pas de bruits radioélectriques dépassant les limites applicables aux appareils numériques de la classe A prescrites dans le Règlement sur le brouillage radioélectrique édicté par le ministère des Communications du Canada.

EN55022 Class A Warning

For products that comply with Class A. In a domestic environment this product may cause radio interference in which case the user may be required to take adequate measures.

Canadian Certified Power Cords

Canadian approval includes the products and power cords appropriate for use in the North America power network. All other power cords supplied are approved for the country of use.

Canadian Certified AC Adapter

Canadian approval includes the AC adapters appropriate for use in the North America power network. All other AC adapters supplied are approved for the country of use.

FCC Emission Limits

This device complies with Part 15 of the FCC Rules. Operation is subject to the following two conditions: (1) This device may no cause harmful interference, and (2) this device must accept any interference received, including interference that may cause undesirable operation.

Certification

This product has been evaluated for Electromagnetic Compatibility under the EN 55103-1/2 standards for Emissions and Immunity and meets the requirements for E4 environment.

This product complies with Class A. In a domestic environment this product may cause radio interference in which case the user may be required to take adequate measures.

This product has been evaluated and meets the following Safety Certification Standards

Category	Standard	Designed/tested for compliance with:
Safety	UL 60950	UL 60950-1 Issue 2007/03/27 Ed. 2 Information Technology Equipment-Safety Part 1 General Requirements.
	IEC 60950	IEC 60950-1 Issue: 2005/12/08 Ed. 2 Information Technology Equipment-Safety Part 1 General Requirements; Corrigendum 1: 8/2006; Amendment 1: 2009/12/17.
	CAN C22.2, No. 60950	C22.2 #60950-1 Issue 2007/03/01 Ed. 2 Information Technology Equipment-Safety-Part 1 General Requirements.
	EN60950	Safety of Information Technology Equipment, including Electrical Business Equipment.
	2006/95/EC	Low Voltage Directive

Category	Standard	Designed/tested for compliance with:
EMC	EMC Directive 2004/108/ EC via EN 55103-1 and 2	Audio, Video and Entertainment Lighting Control for the European Community.
	EN55103-1 : 2009	Electromagnetic compatibility. Product family standard for audio, video, audio-visual and entertainment lighting control apparatus for professional use. Part 1 Emissions, Environment E4 EN 55022: Class A Radiated Emissions EN 61000-3-2: Powerline Harmonic Emissions EN 61000-3-3: Voltage Fluctuations "Flicker" EN 55022: Class A Conducted Emissions Radiated Magnetic Field Emissions Peak Inrush Current
	EN55103-2 : 2009	Electromagnetic compatibility--Product family standard for audio, video, audio-visual and entertainment lighting control apparatus for professional use. Part 2 Immunity, Environment E4 EN 61000-4-3: Radiated RF Immunity EN 61000-4-2: Electrostatic Discharge "ESD" EN 61000-4-4: Electrical Fast Transients "EFT" EN 61000-4-11: Voltage Dips & Fluctuations EN 61000-4-5: Power Line Surge EN 61000-4-6: Conducted RF Immunity Radiated Magnetic Field Immunity
	US FCC Class A	CISPR Pub. 22 (1985)
	Canada FCC Industry Canada	ICES-003
	Australia & New Zealand:	AS/NZS 3548

DEKRA Certificate

Certifying that Grass Valley product meets the ISO 9001: 2008 standard.

CERTIFICATE

Certificate Number: 540040.002

The Environmental Management System of:

Grass Valley, A Belden Brand and its Grass Valley Affiliates

3499 Douglas-B Floreani
Montreal, Quebec
H4S 2C6 Canada

Grass Valley Nederland B.V.

Bergschot 69
4817 PA Breda
The Netherlands

Including its implementation, meets the requirements of the standard:

ISO 14001:2015

Scope:

Montreal: Product Sales, design, manufacture and support of video and audio products and systems.

Breda: Design, manufacture, outsource manufacture and support of video and audio products and systems.

Certificate Expires: November 30, 2021
Certificate Issued: August 07, 2018
Certified Since: December 01, 2000



Dr. Cem O. Onus
Managing Director, Business Assurance
DEKRA Certification, Inc.

1120 Welsh Road, Suite 210
North Wales, PA 19454 USA
(215) 997-4519
dekra-certification.us

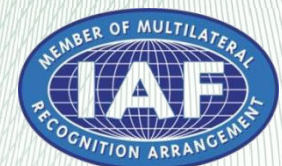
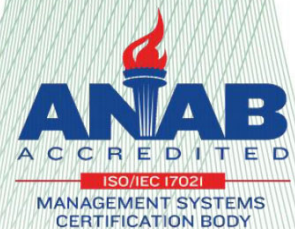



Grass Valley Technical Support

For technical assistance, contact our international support center, at 1-800-547-8949 (US and Canada) or +1 530 478 4148.

To obtain a local phone number for the support center nearest you, please consult the Contact Us section of Grass Valley's website (www.grassvalley.com).

An online form for e-mail contact is also available from the website.

Corporate Head Office

Grass Valley
3499 Douglas-B.-Floreani
St-Laurent, Quebec H4S 2C6
Canada
Telephone: +1 514 333 1772
Fax: +1 514 333 9828
www.grassvalley.com