

Kayak HD

DIGITAL PRODUCTION SWITCHER

Installation Planning Guide

SOFTWARE VERSION 6.9.4

071845103
OCTOBER 2008



Affiliate with the N.V. KEMA in The Netherlands

CERTIFICATE

Certificate Number: 510040.001

The Quality System of:

Grass Valley, Inc.

400 Providence Mine Road
Nevada City, CA 95945
United States

15655 SW Greystone Ct.
Beaverton, OR 97006
United States

10 Presidential Way
3rd Floor, Suite 300
Woburn, MA 01801
United States

Nederland B.V.
4800 RP BREDA
The Netherlands

Weierstadt, Germany
Brunnenweg 9
D-64331 Weierstadt
Germany

Rennes, France
Rue du Clos Courtel
Cesson-Sevigne, Cedex
France

Technopole Brest Iroise
CS 73808
29238 Brest Cedex 3
France

17 rue du Petit Albi-BP 8244
95801 Cergy Pontoise
Cergy, France

2300 South Decker Lake Blvd.
Salt Lake City, UT 84119
United States

7140 Baymeadows Way
Suite 101
Jacksonville, FL 32256
United States

Including its implementation, meets the requirements of the standard:

ISO 9001:2000

Scope:

The design, manufacture and support of video hardware and software products and related systems.

This Certificate is valid until: June 14, 2009
This Certificate is valid as of: August 30, 2006
Certified for the first time: June 14, 2000

H. Pierre Sallé
President
KEMA-Registered Quality

The method of operation for quality certification is defined in the KEMA General Terms And Conditions For Quality And Environmental Management Systems Certifications. Integral publication of this certificate is allowed.

KEMA-Registered Quality, Inc.
4377 County Line Road
Chalfont, PA 18914
Ph: (215)997-4519
Fax: (215)997-3809

CRT 001 073004

Accredited By:
ANAB



Kayak HD

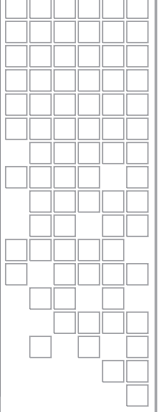
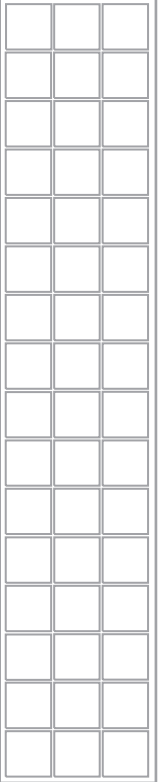
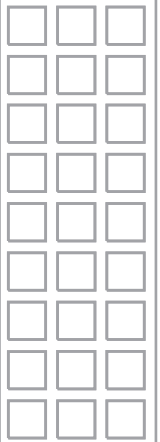
DIGITAL PRODUCTION SWITCHER

Installation Planning Guide



SOFTWARE VERSION 6.9.4

071845103
OCTOBER 2008



Contacting Grass Valley

International Support Centers	France 24 x 7	+800 8080 2020 or +33 1 48 25 20 20 +800 8080 2020 or +33 1 48 25 20 20	United States/Canada 24 x 7	+1 800 547 8949 or +1 530 478 4148
Local Support Centers (available during normal business hours)	Asia	Hong Kong, Taiwan, Korea, Macau: +852 2531 3058 Indian Subcontinent: +91 22 24933476 Southeast Asia/Malaysia: +603 7805 3884 Southeast Asia/Singapore: +65 6379 1313 China: +861 0660 159 450 Japan: +81 3 5484 6868		
		Australia and New Zealand: +61 1300 721 495	Central/South America: +55 11 5509 3443	
		Middle East: +971 4 299 64 40 Near East and Africa: +800 8080 2020 or +33 1 48 25 20 20		
	Europe	Belarus, Russia, Tadzikistan, Ukraine, Uzbekistan: +7 095 2580924 225 Switzerland: +41 1 487 80 02 S. Europe/Italy-Roma: +39 06 87 20 35 28 -Milan: +39 02 48 41 46 58 S. Europe/Spain: +34 91 512 03 50 Benelux/Belgium: +32 (0) 2 334 90 30 Benelux/Netherlands: +31 (0) 35 62 38 42 1 N. Europe: +45 45 96 88 70 Germany, Austria, Eastern Europe: +49 6150 104 444 UK, Ireland, Israel: +44 118 923 0499		

Copyright © Thomson. All rights reserved.

This product may be covered by one or more U.S. and foreign patents.

Grass Valley Web Site

The www.thomsongrassvalley.com web site offers the following:

Online User Documentation — Current versions of product catalogs, brochures, data sheets, ordering guides, planning guides, manuals, and release notes in .pdf format can be downloaded.

FAQ Database — Solutions to problems and troubleshooting efforts can be found by searching our Frequently Asked Questions (FAQ) database.

Software Downloads — Download software updates, drivers, and patches.



END-OF-LIFE PRODUCT RECYCLING NOTICE

Grass Valley's innovation and excellence in product design also extends to the programs we've established to manage the recycling of our products. Grass Valley has developed a comprehensive end-of-life product take back program for recycle or disposal of end-of-life products. Our program meets the requirements of the European Union's WEEE Directive, the United States Environmental Protection Agency, and U.S. state and local agencies.

Grass Valley's end-of-life product take back program assures proper disposal by use of Best Available Technology. This program accepts any Grass Valley branded equipment. Upon request, a Certificate of Recycling or a Certificate of Destruction, depending on the ultimate disposition of the product, can be sent to the requester.

Grass Valley will be responsible for all costs associated with recycling and disposal, including freight. However, you are responsible for the removal of the equipment from your facility and packing the equipment to make it ready for pickup.



For further information on the Grass Valley product take back system please contact Grass Valley at + 800 80 80 20 20 or +33 1 48 25 20 20 from most other countries. In the U.S. and Canada please call 800-547-8949 or 530-478-4148, and ask to be connected to the EH&S Department. Additional information concerning the program can be found at: www.thomsongrassvalley.com/environment



Contents

- Section 1 — System Overview** 3
 - Introduction 3
 - Kayak HD or SD Switcher Models 3
 - Kayak HD Standard Features 4
 - Kayak HD Options 6
 - Supported Control Protocols 7
 - Specifications 8
 - Kayak HD Systems 8

- Section 2 — Control Surfaces** 13
 - Kayak HD Control Panels 13
 - Kayak HD 100C Control Panel 13
 - Dimensions 14
 - Kayak HD 150C, 200C, 200 Control Panels 16
 - Dimensions 17
 - Kayak HD 250C, 250, 300 Control Panels 19
 - Dimensions 20
 - Panel Mounting Options 21
 - Table Top Use 21
 - Surface Mount Cutout Dimensions 21
 - Securing Panels to Mounting Surface 22

- Section 3 — Frames** 23
 - General Rack Mounting Instructions 23
 - 4 RU Compact Frame 24
 - Video Processor Frame Installation 24
 - 4 RU Compact Frame Dimensions 24
 - 4 RU Compact Frame Rack Mounting 26
 - Kayak HD Video Processor 4 RU Frame 27
 - 8 RU Frame 29
 - Video Processor Frame Installation 29
 - 8 RU Frame Dimensions 29
 - 8 RU Frame Rack Mounting 31
 - Cabling 34
 - Kayak HD 100C Control Cabling 34
 - Kayak HD 150C, 200C, and 200 Panel Control Cabling 35
 - Network Cabling 36
 - Ethernet Switches and Hubs 36
 - Factory Network Settings 37
 - Video Cabling for all Kayak HD Switchers 37
 - Inputs 37
 - Outputs 38
 - Reference Input 38

- Section 4 — Options** 39
 - KHD-PSU Internal Redundant Power Supply Option 39

Contents

KDD-PSU Power Supply Option	40
Installation	41
Pin Assignments	42
GPI / Tally Connections	43
Kayak HD GPI and Tally Interface	44
GPI Inputs	44
GPI Input Structure	45
GPI / Tally Outputs	46
Index	1

System Overview

Introduction

The Grass Valley Kayak HD™ digital production switcher is an affordable, compact, and flexible system that offers an array of high-end features for everything from live studio and mobile production to small corporate studios and editing applications. The Kayak HD switcher leverages many of the features found in the Grass Valley KayakDD2™ and Zodiac™ switchers. The result is a compact system with superior image quality and features not found in any other product.

Kayak HD or SD Switcher Models

- Kayak HD or SD 100C, which includes a 1 M/E Control Panel and a compact 4 RU Video Processor Frame
- Kayak HD or SD 150C, which includes a 2 M/E Control Panel and a 4 RU Video Processor frame equipped with one M/E module and the license for a Half M/E
- Kayak HD or SD 200C, which includes a 2 M/E Control Panel and a 4 RU Video Processor frame equipped with two M/E modules
- Kayak HD or SD 200, which includes a 2 M/E Control Panel and a 8 RU Video Processor frame equipped with two M/E modules
- Kayak HD or SD 250C, which includes a 3 M/E Control Panel and a 4 RU Video Processor frame equipped with two M/E modules and the license for a Half M/E
- Kayak HD or SD 250, which includes a 3 M/E Control Panel and an 8 RU Video Processor frame equipped with two M/E modules and the license for a Half M/E
- Kayak HD or SD 300, which includes a 3 M/E Control Panel and an 8 RU Video Processor frame equipped with three M/E modules

Frame-only models are available for the configurations listed above and include the following:

- Kayak HD or SD 350 Frame-only which includes an 8 RU Video Processor frame equipped with three mix/effects and the license for a Half M/E
- Kayak HD or SD 400 Frame-only which includes an 8 RU Video Processor frame equipped with four mix/effects
- Kayak HD or SD 450 Frame-only which includes an 8 RU Video Processor frame equipped with three mix/effects and the license for a Half M/E

Kayak HD Standard Features

- Switchable between several HD formats
- Supports SD production
- Fully digital 10-bit, 4:2:2 inputs, outputs
- Compact 4 RU and 8 RU lightweight frames
- Low power consumption
- Hot swappable, front removable modules and power supplies
- Intuitive menu with touch screen
- One DPM Channel standard per M/E with planar 3D effects, remaining channels optional, adding non-linear and lighting effects (Software License Key (SLK))
- Two high-quality chroma keyers standard
- Number of M/Es:
 - One for Kayak HD 100C
 - 1.5 for Kayak HD 150C
 - Two for Kayak HD 200, 200C
 - 2.5 for Kayak HD 250, 250C
 - Three for Kayak HD 300
 - 3.5 for Kayak HD 350
 - 4 for Kayak HD 400
 - 4.5 for Kayak HD 450

Note .5 M/E includes cuts and mixes, no wipes or iDPM, with simple linear/luminance keyers and no chroma keys.

- Number of inputs:
 - 24 to 48 for Kayak HD 100C, 150C
 - 48 for Kayak HD 200C, 250C
 - 48 to 96 for Kayak HD 200, 250
 - 72 to 96 for Kayak HD 300, 350
 - 96 for Kayak HD 400, 450
- Number of outputs:
 - 12 to 24 for Kayak HD 100C, 150C
 - 24 for Kayak HD 200C, 250C
 - 24 to 48 for Kayak HD 200, 250
 - 36 to 48 for Kayak HD 300, 350
 - 48 for Kayak HD 400, 450
- Video outputs programmable as M/E, Program or AUX bus outputs
- GPI (General Purpose Interface) inputs:
 - Eight to 16 for Kayak HD 100C, 150C
 - 16 for Kayak HD 200C, 250C
 - 16-32 for Kayak HD 200, 250
 - 24-32 for Kayak HD 300, 350
 - 32 for Kayak HD 400, 450
- GPI/Tally Outputs:
 - 32-64 for Kayak HD 100C, 150C
 - 64 for Kayak HD 200C, 250C
 - 64-128 for Kayak HD 200, 250
 - 96-128 for Kayak HD 300, 350
 - 128 for Kayak HD400, 450
- Four full-function keyers per full M/E, each with linear and luminance keying
- Five background generators include black, white, and three color backgrounds
- Test Pattern Generator
- Two analog reference inputs (tri-level sync and black burst) and HD/SD serial digital input reference
- White or colored pushbutton keycaps (factory installed, choose when ordered)
- Freeze frame buffer on every full-function keyer

- Two main wipe generators and 4 keyer wipe generators per M/E
- YUV Color correction on every keyer and background bus
- Internal four-port Gigabit Ethernet (10/100/1000 base T) switch
- Eight serial ports for external machine control

Kayak HD Options

- Internal six-channel RAMRecorder option for video clips and stills
- Three additional iDPMs with 2D transforms and crops on keyers 2, 3, and 4 per M/E
- DPM Kurl per M/E. Adds Kurl effects to all of the enabled DPMs in one M/E. Includes Page Turn, Page Roll, Spheres, Ripples, Splits, Mirrors, and Slits
- DPM Spektra Lighting, Defocus, Glow, and Output Recursives. Adds Spektra effects to all of the enabled DPMs in one M/E.
- Four channels of eDPM with 2D transforms and crops that re-enter on any M/E
- Kurl for eDPM
- Spektra for eDPM
- RGB color correction option on every keyer and background bus, or per input
- Dual Chromatte™ chroma keyers, with flexible licenses allowing assignment of Chroma keys to different keyers
- Remote monitoring and diagnostic support via NetCentral software
- KHD-PSU internal redundant power supply unit
- KDD-PSU rack-mounted remote power supply unit for remote (or additional) control panels
- MatchDef™ Dual Video Source Scalar for converting 2 SD or HD sources to the production format, maximum of 4 for up to 8 sources in the 4 RU models, up to 16 sources in the 8 RU models. One Mix/Effects or IOXPAND option required for every four sources. Scalars accept either HD or SD input and act as a frame-sync when not converting or being bypassed.
- DSK (Downstream Keyer)/ Half M/E option for full M/E systems. (SLK)
 - Adds four DSKs for up to 20 keyers for 4.5 M/Es in the 8RU frame
 - Adds four DSKs for up to 12 keyers in the 4RU frame
 - Or Half M/E Mode with A/B background mix and four Lin/Lum keyers

- I/O Expander Module adds 24 SDI inputs, 12 SDI outputs, 8 GPI inputs, 32 GPI outputs/tallies, and optionally 4 MatchDef™ scalar inputs. Fits in any available M/E slot.
- Full M/E Upgrade Option. Adds one Mix/Effects module to any Kayak HD chassis. Order one or more options to get the total M/Es required. The 4RU chassis holds up to two M/E modules and/or I/O Expander modules. One M/E upgrade option can be added to a Kayak HD 1-M/E or 1.5-M/E system if it does not also have an I/O Expander module. The 8RU chassis holds up to four M/E modules and/or I/O Expander modules. One or two upgrade options can be added to a Kayak HD or SD 2-M/E system, less any I/O Expander modules in the chassis.
- Upgrade Kit for minor modifications of XtenDD panels to enable control of a Kayak HD/SD video processor frame.

Supported Control Protocols

- VTRs (BVW-75)
- AMP (Advanced Media Protocol). For Profile PVS, XP, K2, M Series, and Turbo DDRs. RS422 Serial supported
- Video servers (Louth VDCP, Odetics)
- Routers/Routing Control Systems (Trinix™, Venus™, Triton™, and third party routers; Jupiter™ and Encore™ router control systems)
- Control Systems (Grass Valley Andromeda™ and third-party systems)
- Grass Valley Under Monitor Displays (Serial tally for UMD. Requires Grass Valley Andromeda™ system or third-part tally box such as Tally Display Corp. or Image Video.)
- Grass Valley external Remote AUX Panels (CP-300 Series)
- ESAM II for audio-follow-video applications
- Edit controllers (native and Grass Valley Model 100 and 200 or DD35)

Specifications

Kayak HD Systems

Table 1. Kayak Mechanical Specifications

Component	Depth	Width	Height	Weight ^a	Rack Units
Control Surfaces					
Kayak HD 100C	418 mm (16.5 in.)	448 mm (17.6 in.)	145.80 mm (5.74 in.)	7 kg (15.4 lbs)	n/a
Kayak HD 150C, 200C, 200	418 mm (16.5 in.)	809 mm (31.8 in.)	145.80 mm (5.74 in.)	10 kg (22 lbs)	n/a
Kayak HD 250C, 250, 300	544 mm (21.42 in.)	1132 mm (44.57 in.)	162 mm (6.38 in.)	18 kg (39.68 lbs)	n/a
Frames					
Kayak HD Compact 4 RU Frame					
Kayak HD 100C and 150C	546.10 mm (21.5 in.)	482.60 mm (19 in.)	177.8 mm (7 in.)	16.33 kg (36 lbs)	4
Kayak HD 200C and 250C	546.10 mm (21.5 in.)	482.60 mm (19 in.)	177.8 mm (7 in.)	17.69 kg (39 lbs)	4
Kayak HD 8 RU Frame					
Kayak HD 200 and 250	522.73 mm (20.58 in.)	482.60 mm (19 in.)	441.96 mm (17.4 in.)	29.03 kg (64 lbs)	8
Kayak HD 300	522.73 mm (20.58 in.)	482.60 mm (19 in.)	441.96 mm (17.4 in.)	30.39 kg (67 lbs)	8
KDD-PSU Remote Panel Power Supply Option	240 mm (9.45 in.)	482 mm (19 in.)	44 mm (1.73 in.)	2.8 kg (6.2 lb.)	1

^a All weights approximate.

Table 2. Environmental

Storage temperature	-20 to 70 deg C (-4 to 158 deg F)
Operating temperature	0 to 40 deg C (68 to 104 deg F)
Relative humidity	0-95% (non-condensing)
Electromagnetic environment	E2 (according to EN55103-1, -2)

Table 3. Control Panel Connection

Type of connection	10/100 Base T
Protocol	TCP(UDP)/IP
Cable and connectors	CAT5 UTP, RJ45 connectors;
Max. Cable Length	100m / 300ft
1 Frame and up to 4 Panels connect without use of external hub/switch.	

Table 4. Power

4 RU Frame	
Line voltage	100V-240V AC +/-10% autorange, power factor corrected. Automatic line-voltage sensing for 120V and 240V sources.
Line frequency	50/60Hz +/- 5%
Power consumption	max. 400W
Leakage current	< 2.5 mA
DC-OUT for control panel	48V DC, max 3A
8 RU Frame	
Line voltage	100V-240V AC +/-10% autorange, power factor corrected. Automatic line-voltage sensing for 120V and 240V sources.
Line frequency	50/60Hz +/- 5%
Power consumption	max. 800W
Leakage current	< 2.5 mA
DC-OUT for control panel	48V DC, max 3A
Kayak HD 100C Control Panel	
DC-IN	48V DC In, max 1.3A
Kayak HD 150C, 200C, 200 Control Panel	
DC-IN	48V DC In, max 1.3A
Kayak HD 250C AND 250 Control Panels	
DC-IN	48V DC In, max 1.3A
Kayak HD 300 Control Panel	
DC-IN	48V DC In, max 1.3A
KDD-PSU Frame (Remote Control Panel Power Supply)	
Line voltage	100V-240V AC +/-10%, power factor corrected
Line frequency	50/60Hz +/- 5%
Power consumption	max. 375W
Leakage current	< 2 mA at 250V AC

Table 5. Serial Digital Video Inputs

Format	ITU-R656, SMPTE 259M, 270Mbit/s. SMPTE 292M, 1.5Gbit/s
Number of Inputs	Kayak HD 100C, 150C: 24 to 48
	Kayak HD 200C, 250C: 48
	Kayak HD 200, 250: 48 to 96
	Kayak HD 300: 72 to 96
Return loss	> 15 db, 5 MHz to 1.5 GHz
Type of Connector	75 ohm BNC (SMPTE 259M)
Interface	HD Video Formats SMPTE 292M-1998
	SD Video Formats SMPTE 259M-1997
Nominal Amplitude	800mV peak-to-peak terminated
Autophasing range	TBD
Channel Coding	conforms to SMPTE 259M, SMPTE 292M
Ancillary Data	Blanked or passed (user selectable)
Embedded audio	Blanked or passed (user selectable)
EDH	Blanked
Input Impedance	75 ohm
Max cable length	HD Video 100 meters using Belden 1694A type cable
	SD Video 300 meters using Belden 1694A type cable

Table 6. Serial Digital Video Outputs

Format	ITU-R656, SMPTE 259M, 270Mbit/s. SMPTE 292M, 1.5Gbit/s
Number of Outputs	Kayak HD 100C, 150C: 12 min., Up to 24
	Kayak HD 200C, 250C: 24
	Kayak HD 200, 250: 24 min., Up to 48
	Kayak HD 300: 36 min., Up to 48
Return loss	> 15 db, 5 MHz to 1.5 GHz
Type of Connector	75 ohm BNC (SMPTE 259M)
Interface	HD Video Formats SMPTE 292M-1998
	SD Video Formats SMPTE 259M-1997
Nominal Amplitude	800 mv peak-to-peak across 75 ohm
Rise & Fall Times	400 to 1400picoseconds 75 ohm termination between 20% and 80% amplitude
Jitter	ITU R 601/656
Output Impedance	75 ohm
DC Offset	< 50mV with 75 ohm termination

Table 7. Analog Reference Input

Video Standard	For HD Video: Tri-level Sync, Analog equivalent to the standard being used
	For SD Video: Color Black, Analog equivalent to the standard being used
Return loss	> 40dB, up to 5 MHz
Connectors	2 each BNC loop through for both HD and SD inputs
Impedance	75 ohm external

Table 8. Kayak HD Video Standards

HD Mode		SD Mode	
1080i 29.97/30	SMPTE 274M Table 1-4, 5	525i 59.94	SMPTE 259M
1080i 25	SMPTE 274M Table 1-6	625i 50	SMPTE 259M
1080p 24/23.976	SMPTE 274M Table 1-10, 11		
1080sF 24/23.976	SMPTE 211 Table 1-15, 16		
720p 60/59.94/50	SMPTE 296 Table 1-1, 2		

Control Surfaces

Kayak HD Control Panels

Kayak HD Production Switcher systems use a control panel with integrated menu display (color TFT with touch-screen). Three control panels and two electronics frames provide seven unique Kayak HD systems.

Kayak HD 100C systems use a one M/E panel.

The control panel used in Kayak HD 150C, 200C, and 200 systems provides one M/E plus program/preset, or two M/E (depending upon electronics frame configuration).

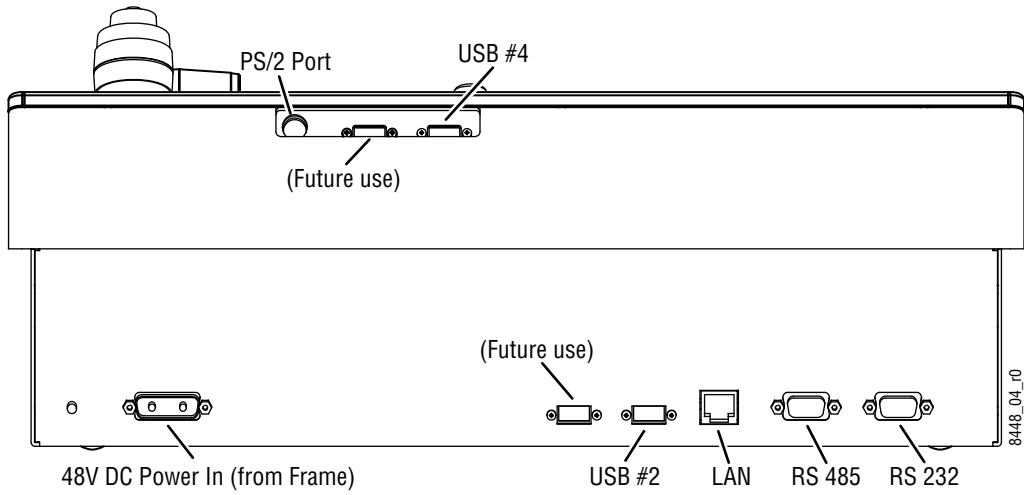
The control panel used in Kayak HD 250C, 250, and 300 systems provides two M/E plus program/preset, or three M/E (depending upon electronics frame configuration).

Kayak HD 100C Control Panel

Figure 1. Control Panel

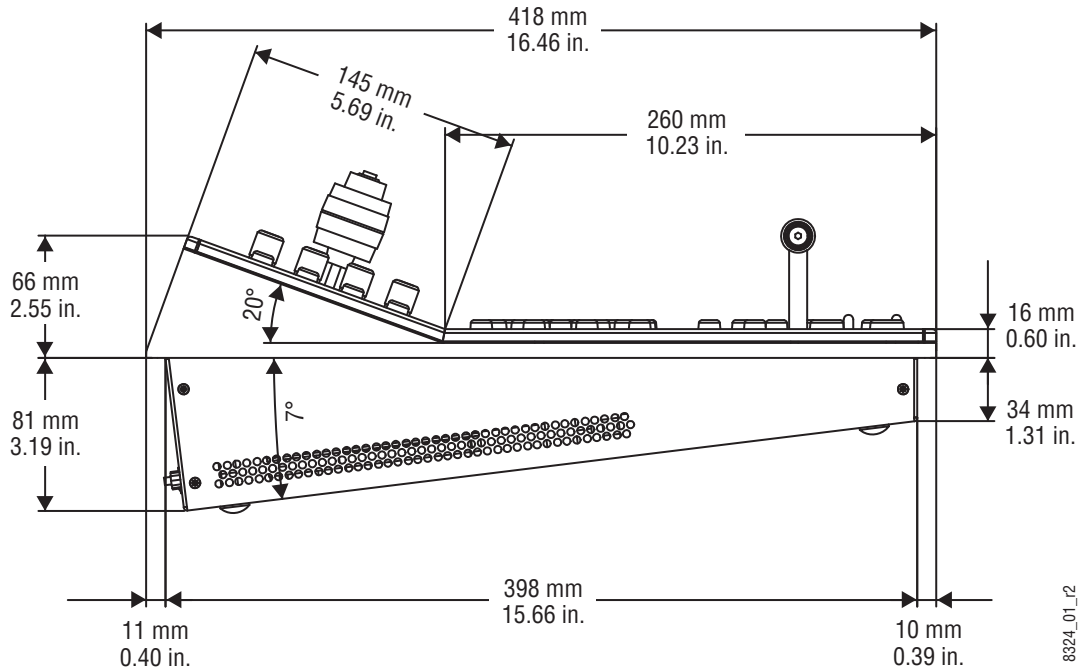


Figure 2. 1 M/E Control Panel, Rear View



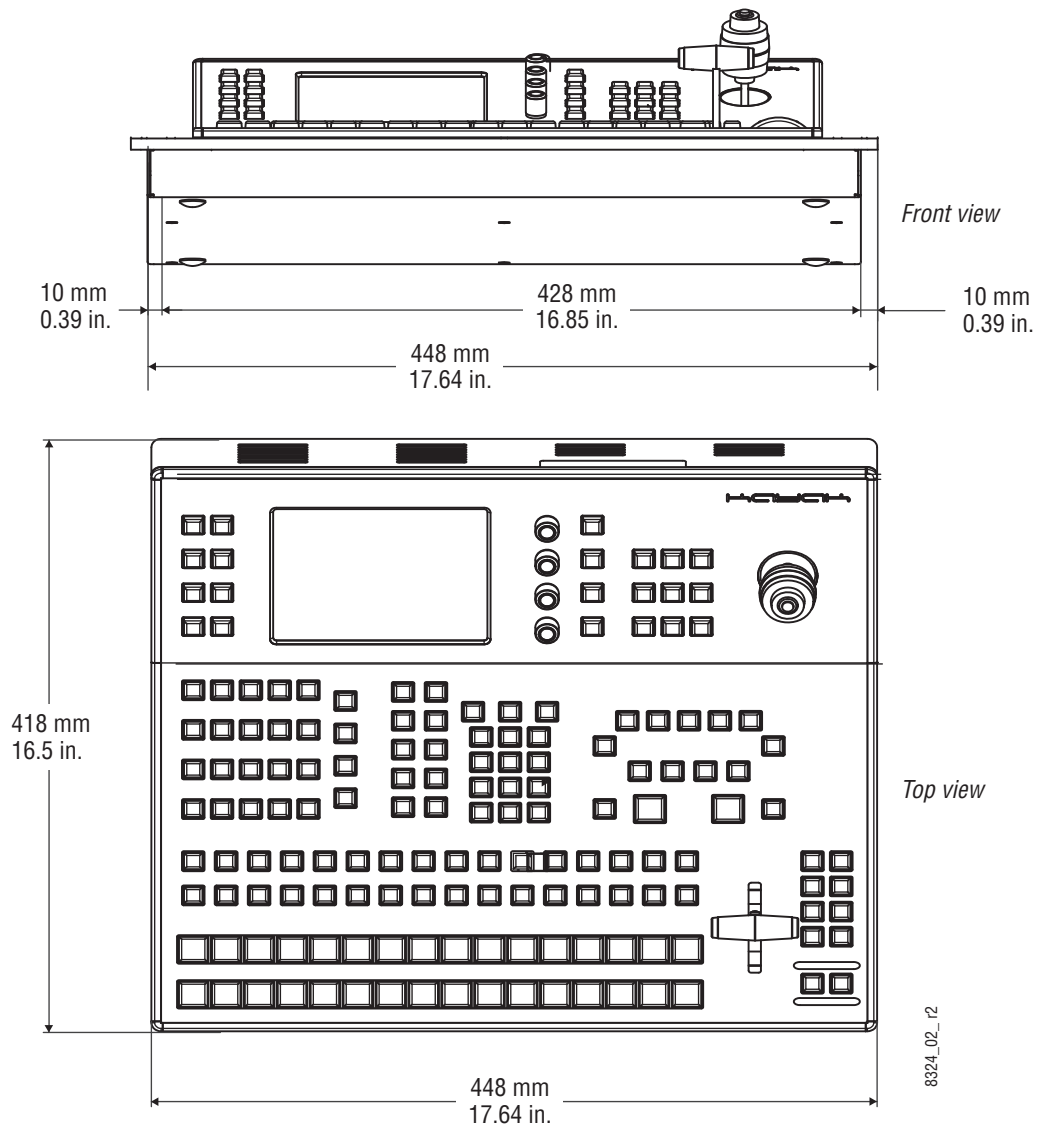
Dimensions

Figure 3. Kayak HD 100C Control Panel Dimensions 1 of 2



Left side view

Figure 4. Kayak HD 100C Control Panel Dimensions 2 of 2

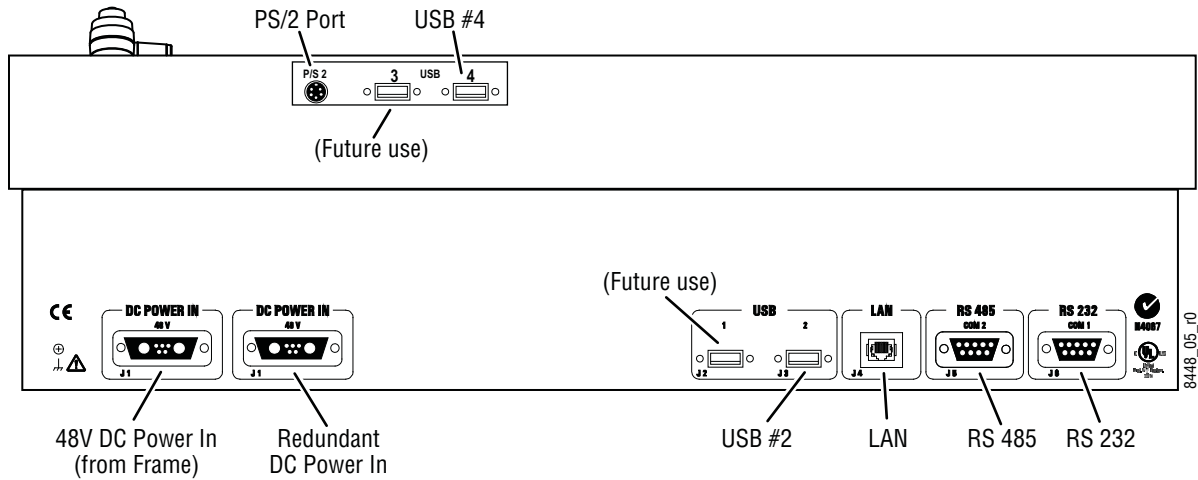


Kayak HD 150C, 200C, 200 Control Panels

Figure 5. Kayak HD 150C, 200C, and 200 Control Panel



Figure 6. 2 M/E Control Panel, Rear View



Dimensions

Figure 7. Kayak HD 150C, 200C, and 200 Control Panels Dimensions 1 of 2

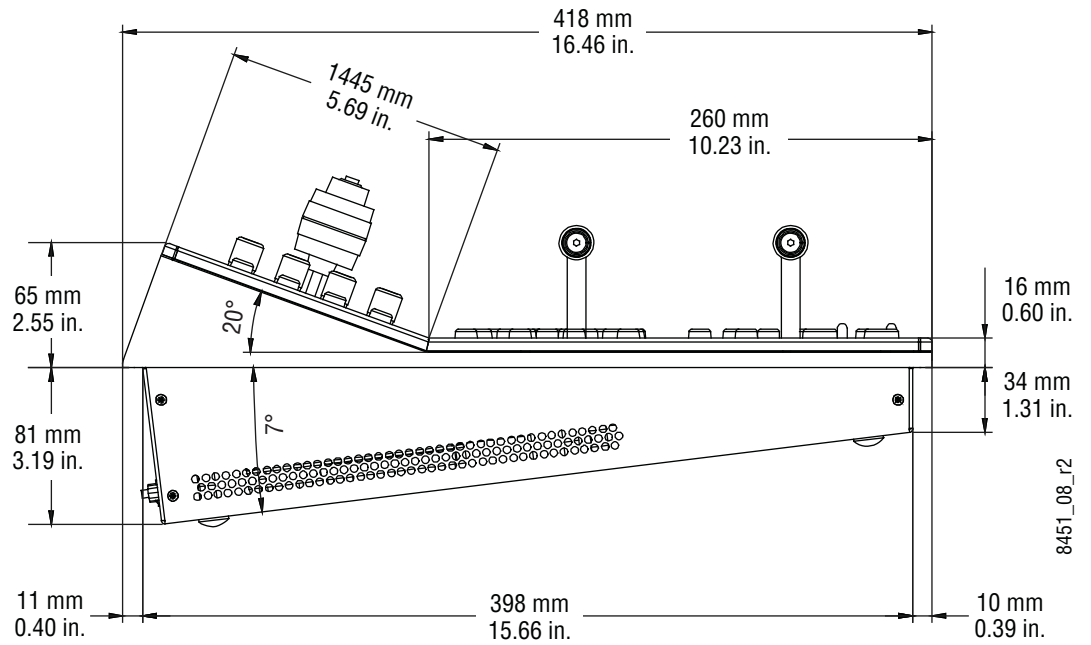
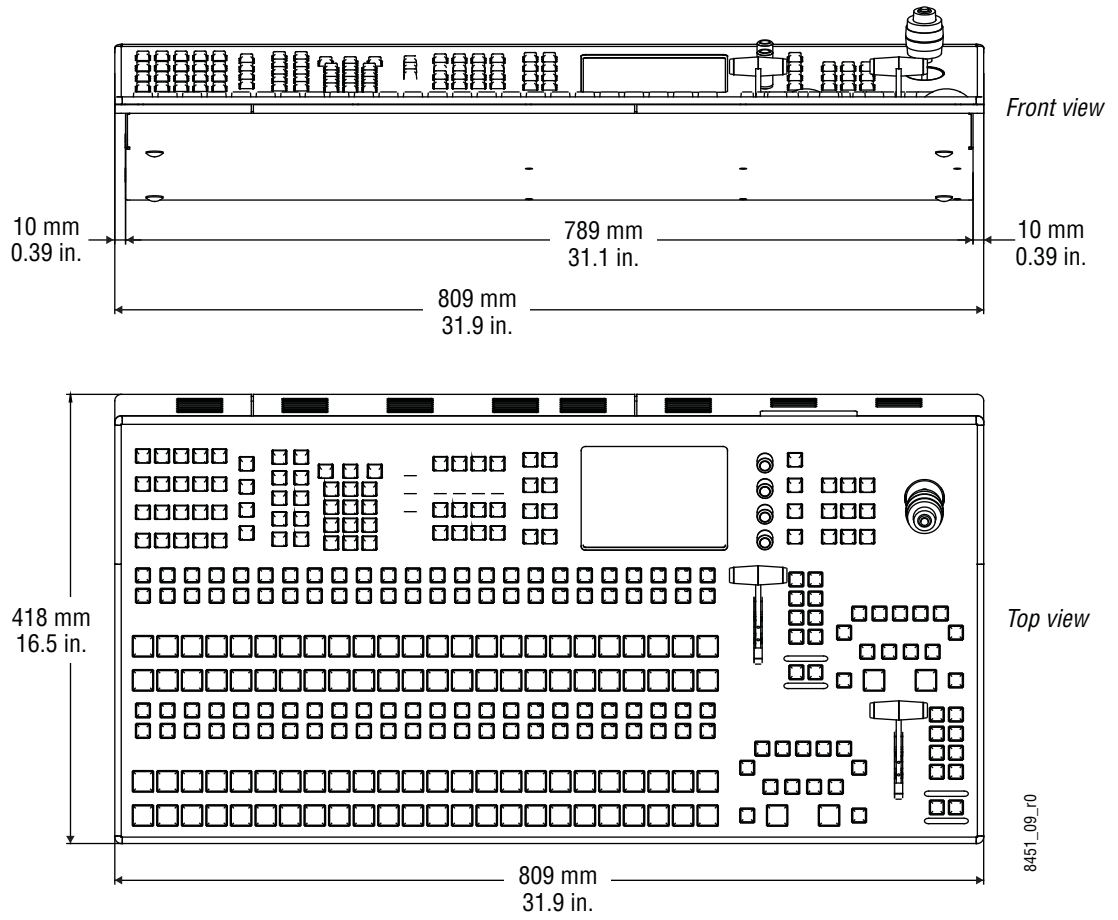


Figure 8. Kayak HD 150C, 200C, and 200 Control Panel Dimensions 2 of 2



Kayak HD 250C, 250, 300 Control Panels

Figure 9. Kayak HD 250C, 250, and 300 Control Panel

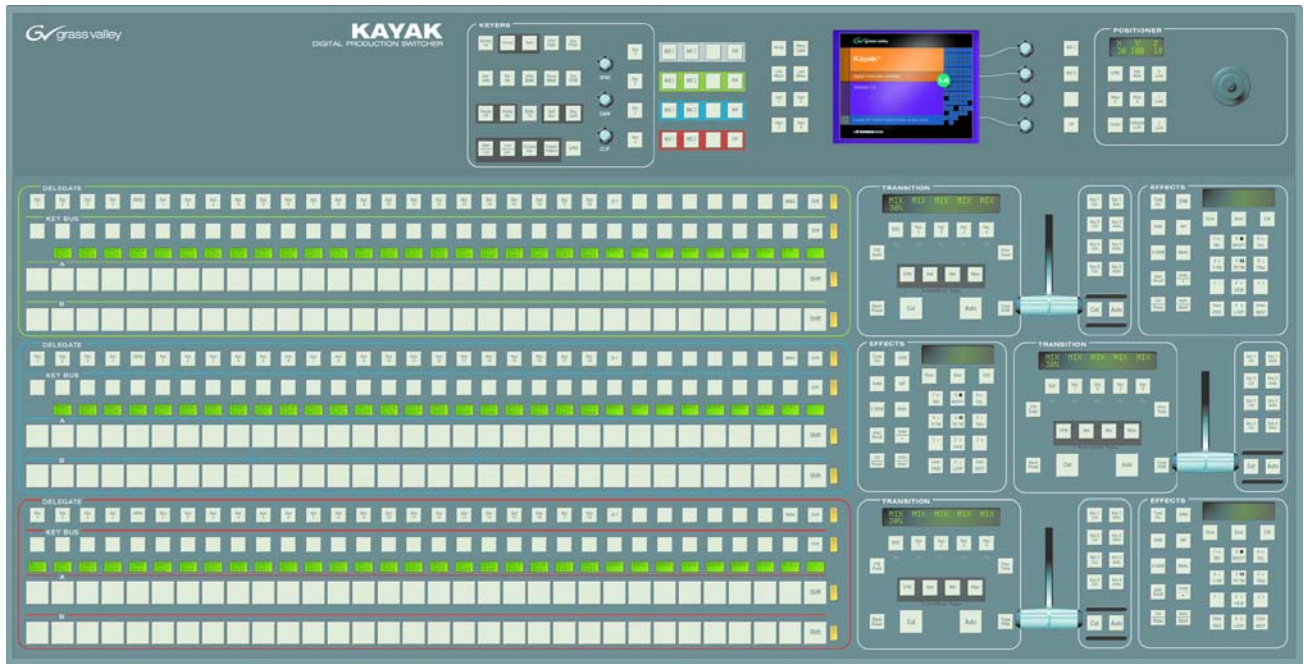
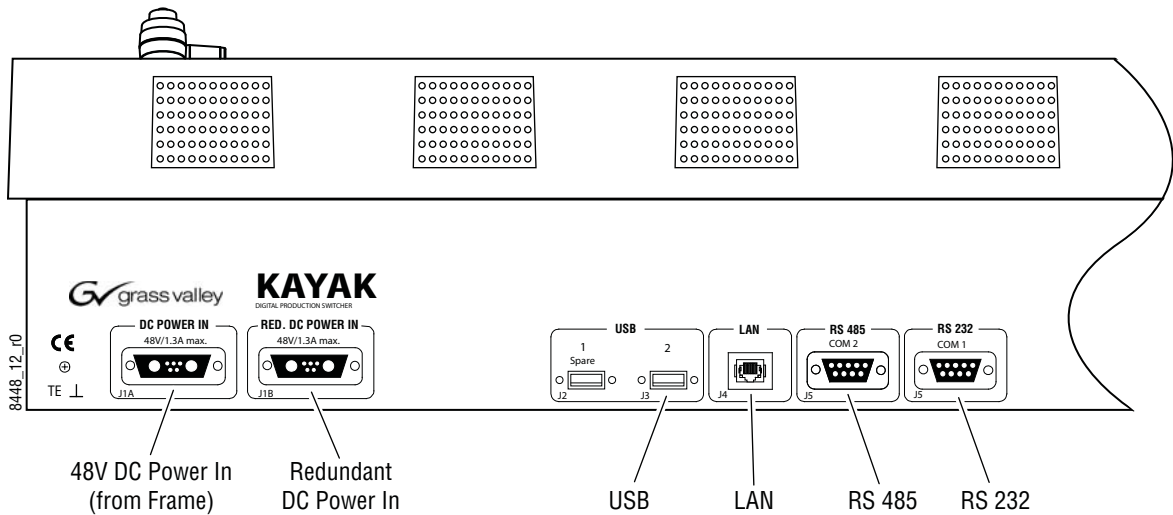
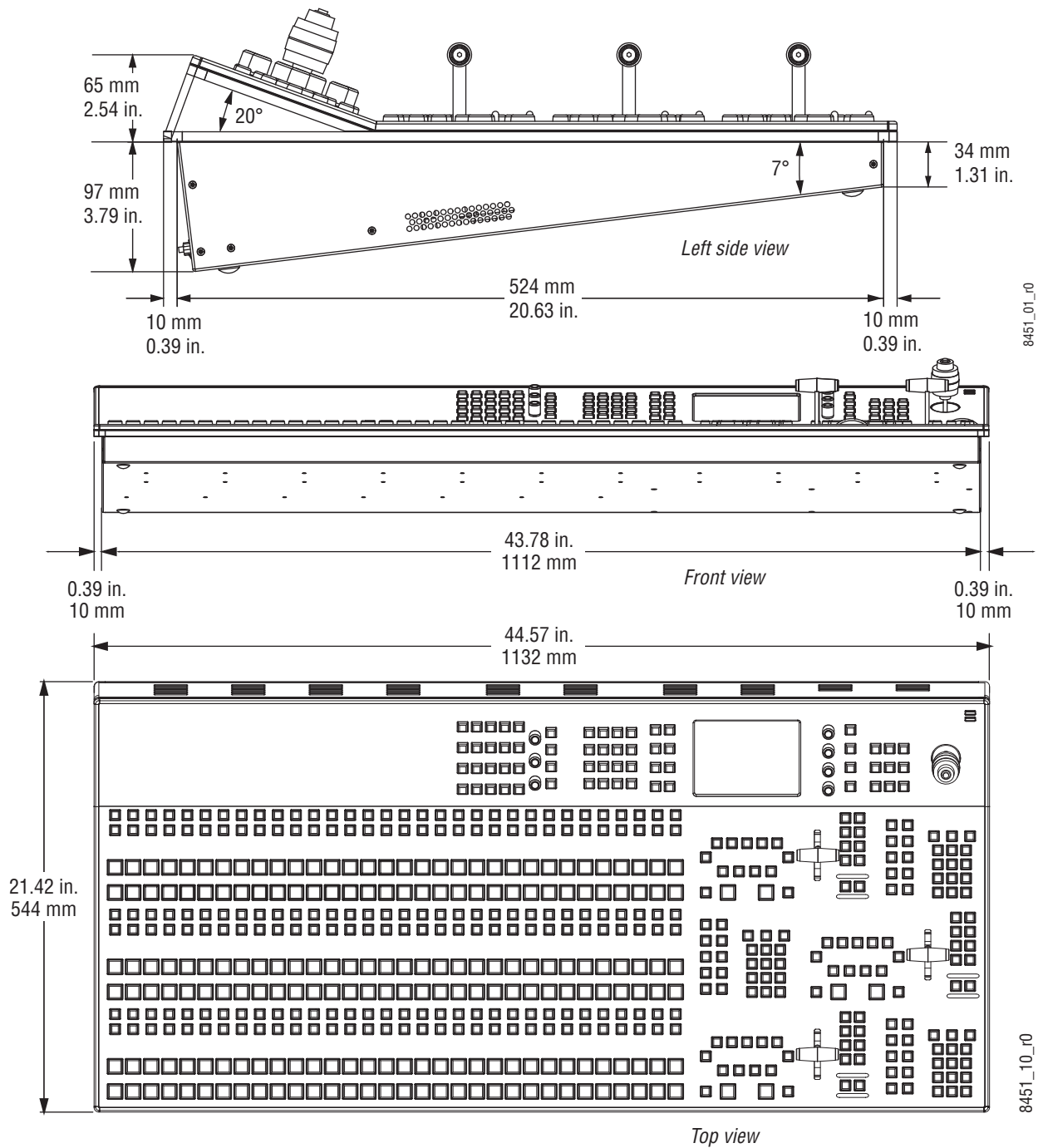


Figure 10. 3 M/E Control Panel, Rear View



Dimensions

Figure 11. Kayak HD 250C, 250, and 300 Control Panels Dimensions



Panel Mounting Options

Kayak HD control panels may be placed on a table or similar stable surface, or they may be recessed into a control console in an appropriately sized cutout.

Table Top Use

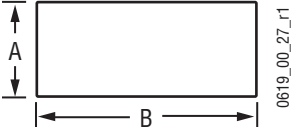
High-friction feet prevent inadvertent movement of the panel. The panel is ventilated at its sides. Ensure that production materials and other equipment does not block the ventilation holes on the sides of the panel.

CAUTION At least 2 in. (50mm) of open space on the sides of the panel is required for proper air flow.

Surface Mount Cutout Dimensions

Table 1. Kayak HD Surface Mount Cutout Dimensions

Cutout Dimensions		
Control Surfaces	A	B
Kayak HD 250C, 250, 300	526 mm (20.71 in.)	1114 mm (43.86 in.)
Kayak HD 150C, 200C, 200	400 mm (15.75 in.)	791 mm (31.14 in.)
Kayak HD 100C	400 mm (15.75 in.)	430 mm (16.93 in.)

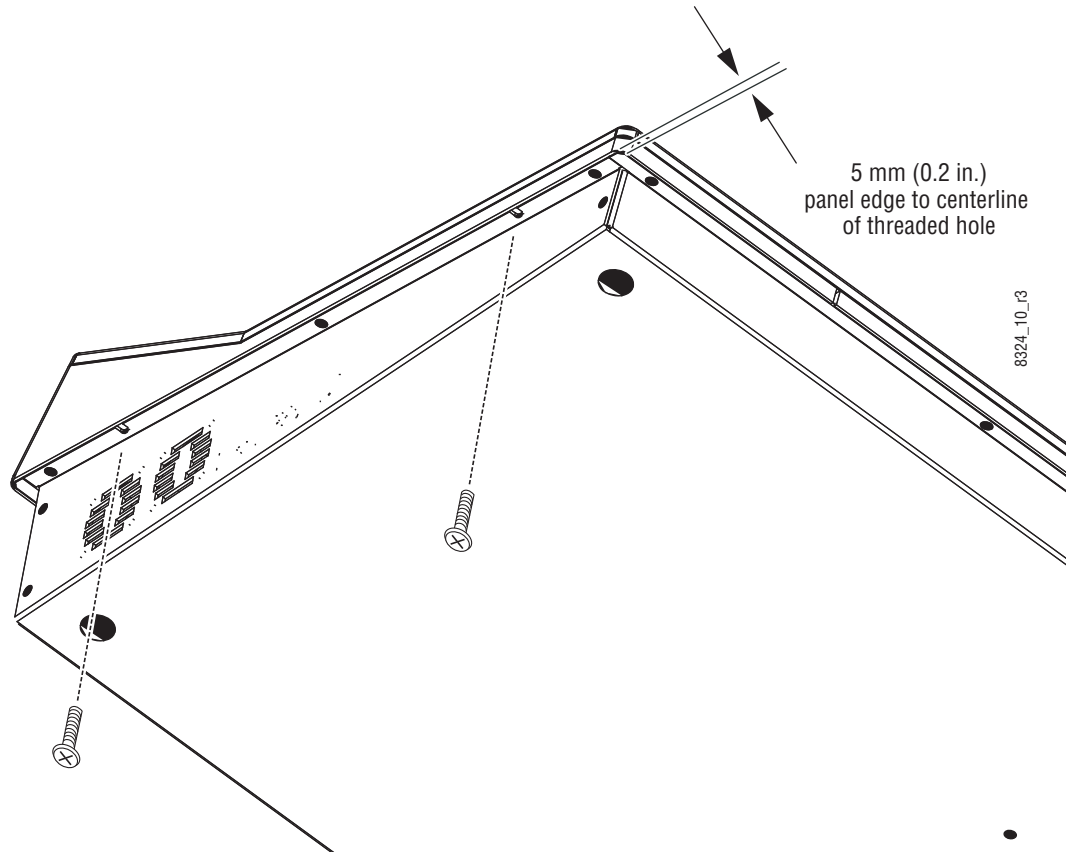


CAUTION At least 50 mm (2 in.) of clear space on the sides of the panel below the mounting surface is required for proper air flow. Provide at least 50 mm (2 in.) of clear space in the rear of the panel for cable clearance.

Securing Panels to Mounting Surface

When mounting the panel in a tabletop cutout, four M4 threaded holes (two each on the left and right side of the panel) are available for securing the panel in the cutout (Figure 12).

Figure 12. Kayak HD Panel Mounting Holes



Frames

General Rack Mounting Instructions

The maximum ambient temperature for this unit is 40-degrees C (104-degrees F).

Installing the frame in a closed or multi-unit rack assembly together with other units could increase the maximum ambient temperature for this unit.

If the unit is installed in a rack, no ventilation openings should be blocked or otherwise covered. Make sure you install the frame so that you allow for cooling airflow.

Make sure that you mount the unit in the rack so that it is evenly balanced to prevent damage to the frame and to avoid creating a hazardous condition.

When connecting the unit to the supply circuit be sure that the supply circuit of the rack is not overloaded. The unit must be well-grounded using the ground connector on the rear. When connecting the unit in a closed or multi-unit rack assembly together with other units be sure that the sum of the touch (leakage) currents for all power supplies does not exceed 3.5 mA.

CAUTION Ambient air temperature must be taken into consideration when installing your Kayak video processor chassis. Do not place the air intake side of the Kayak chassis near the air output of another piece of equipment if that output exceeds the maximum Operating Temperature specification.

4 RU Compact Frame

Video Processor Frame Installation

4 RU Compact Frame Dimensions

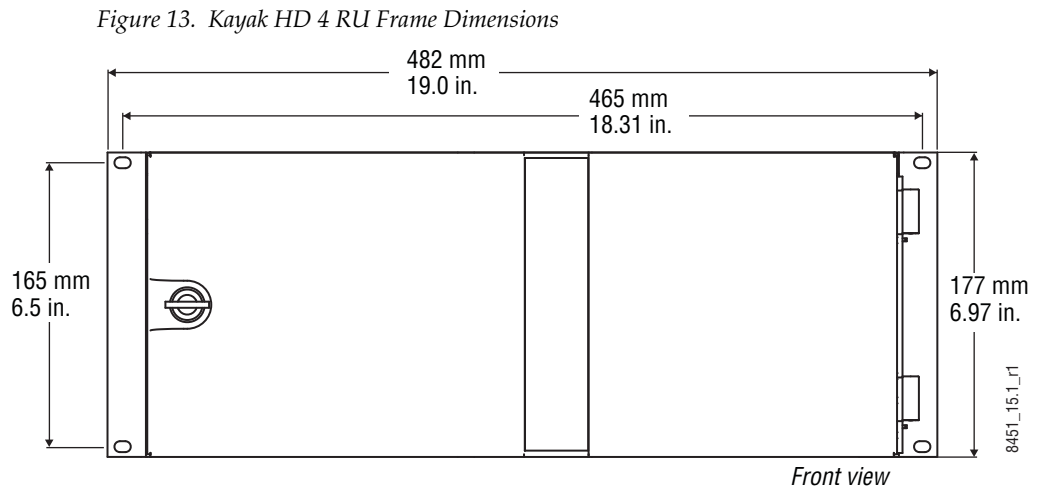
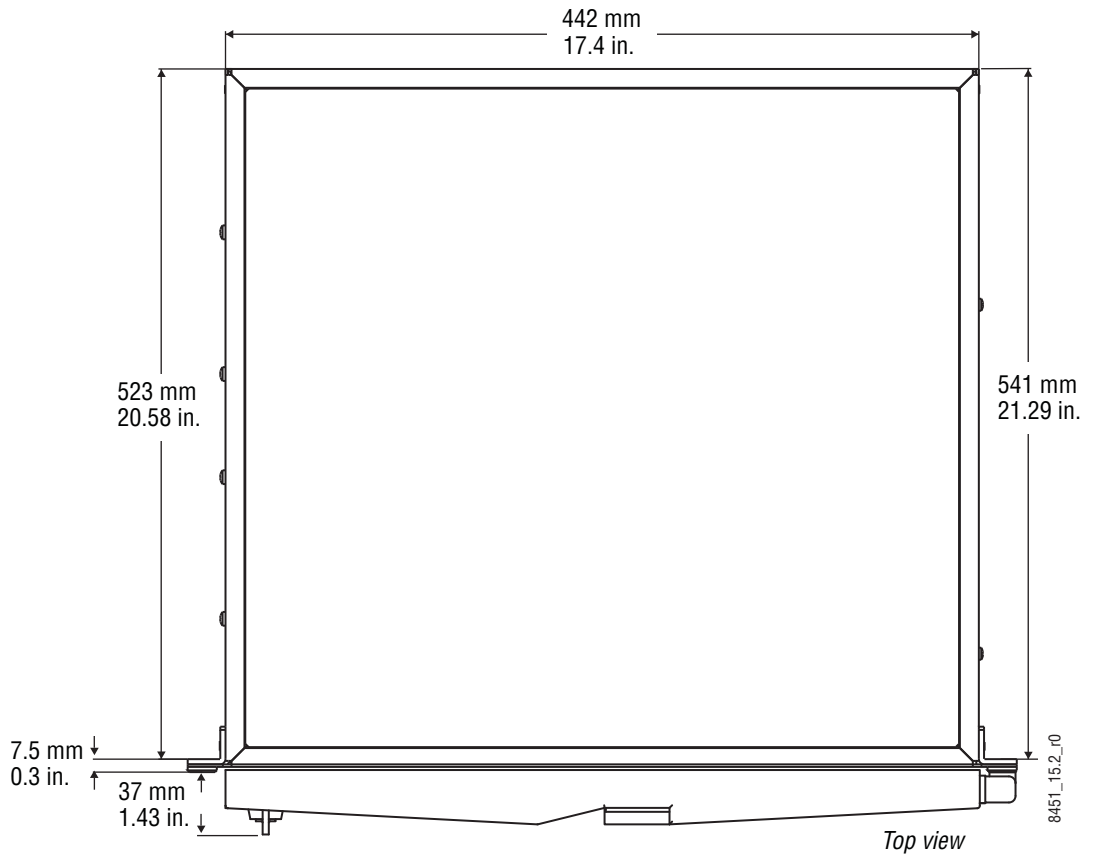
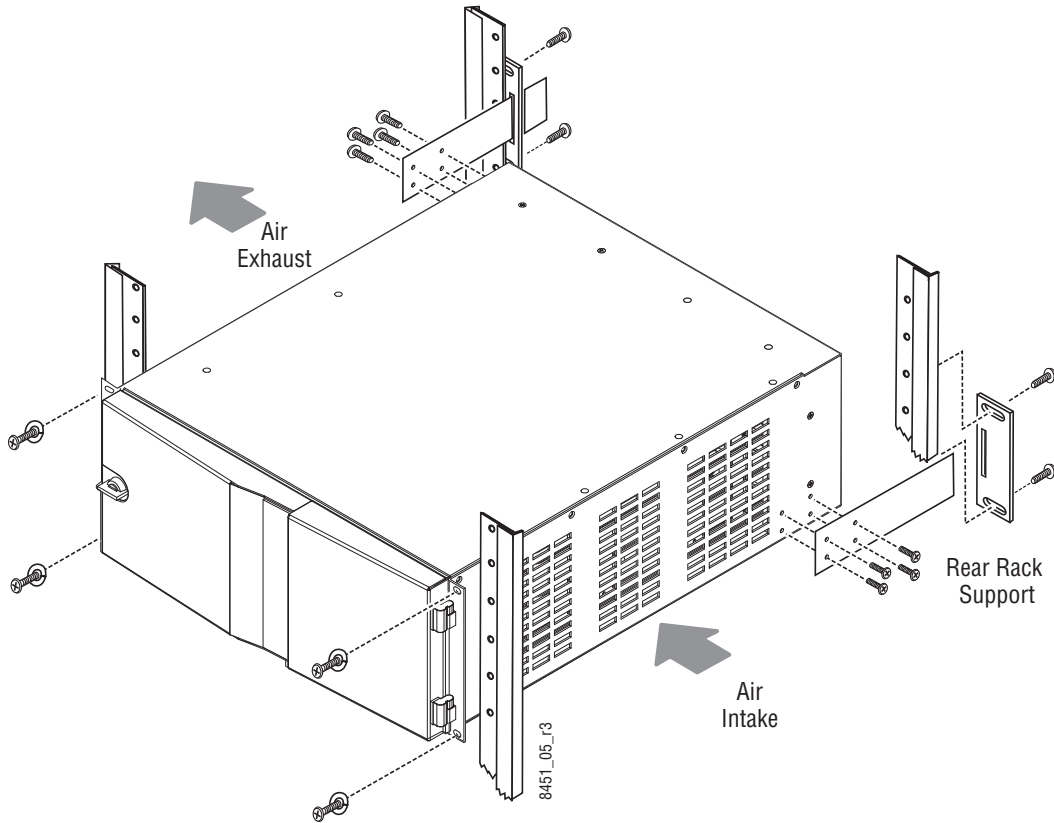


Figure 14. Kayak HD 4 RU Frame Dimensions



4 RU Compact Frame Rack Mounting

Figure 15. Kayak HD 4 RU Compact Frame Rack Mounting



CAUTION Mounting using only the front rack ears is sufficient for fixed installations. Additional support, like the rear rack support or slide rails, is required for mobile applications.

The Rear Rack support provides additional support and stability for the Kayak HD frame to ensure that it remains horizontal.

Make sure to provide adequate ventilation for the Kayak HD Frame. When installing the frame in the rack, take care that no ventilation holes are blocked. This can prevent cooling air from reaching the frame and cause it to overheat.

There are air intake holes on the right side of the frame (as you face the frame front) and air exhaust holes on the left.

CAUTION A minimum vertical clearance of 7.62 mm (0.3-in.) above the Kayak HD 4 RU Compact frame door is required to remove the door. When installing the Kayak HD 4 RU Compact frame in the rack, take care to leave room for removal of the front door. The front door lifts off vertically and must have sufficient clearance room in order to remove it. If you have equipment mounted too close to the Kayak HD 4 RU Compact Frame, you may not be able to remove the door.

Kayak HD Video Processor 4 RU Frame

Figure 16. Kayak HD 4RU Frame, Front View with Door Removed

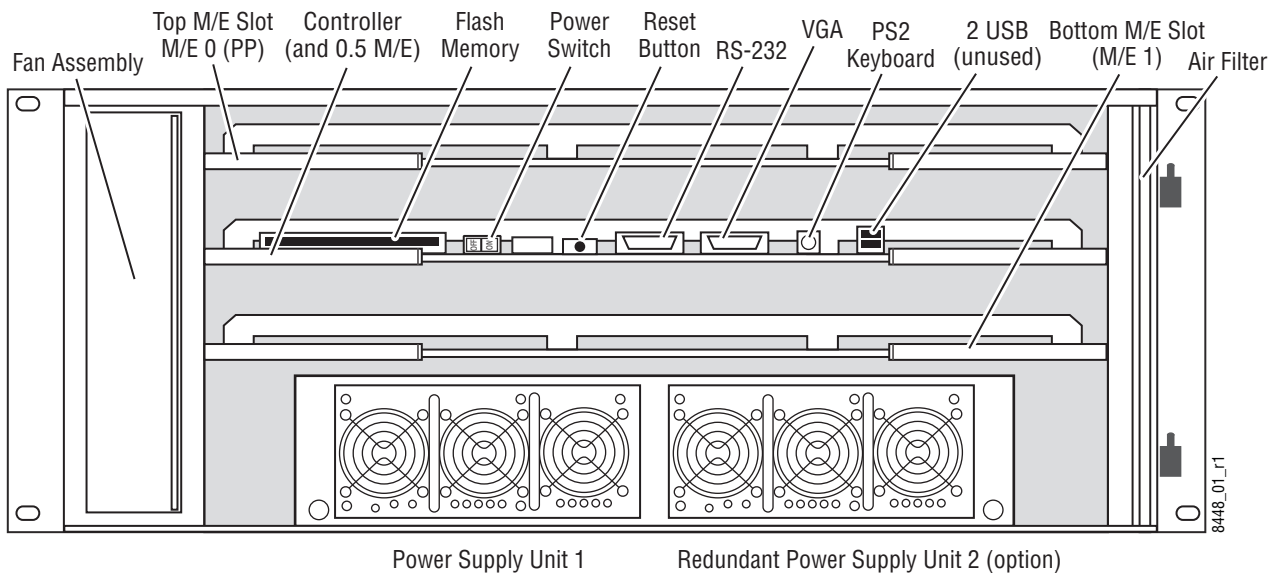
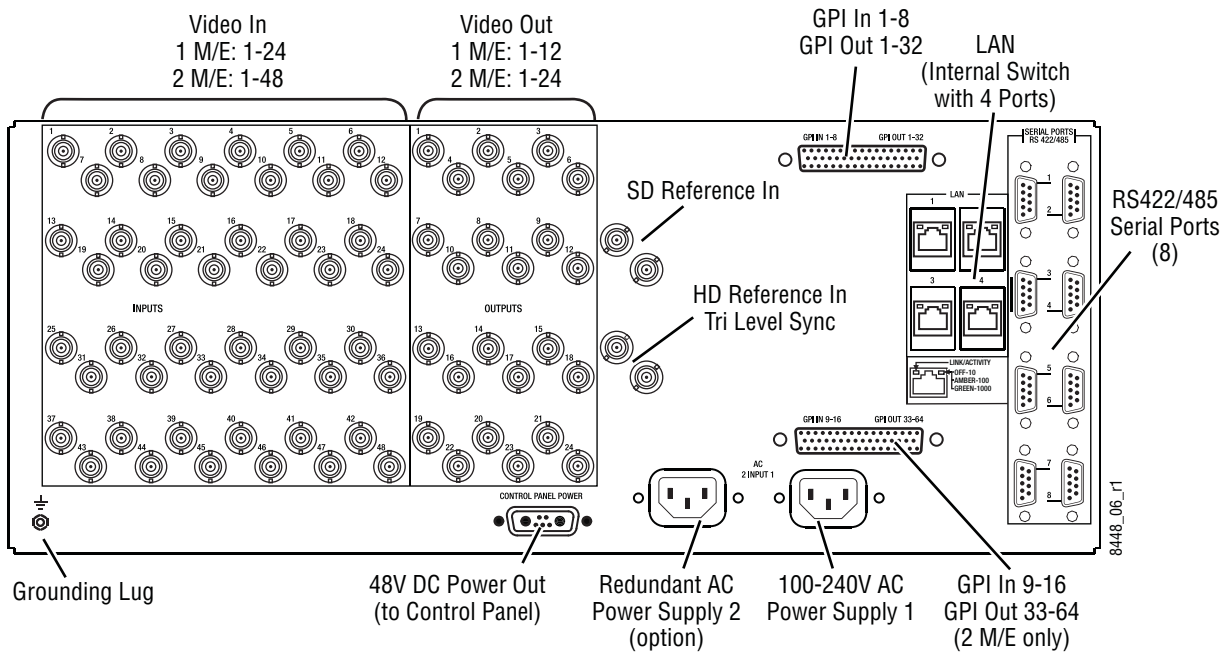


Figure 17. Kayak HD 4RU Frame, Backplane View



8 RU Frame

Video Processor Frame Installation

8 RU Frame Dimensions

Figure 18. Kayak HD 8 RU Frame Dimensions 1 of 2

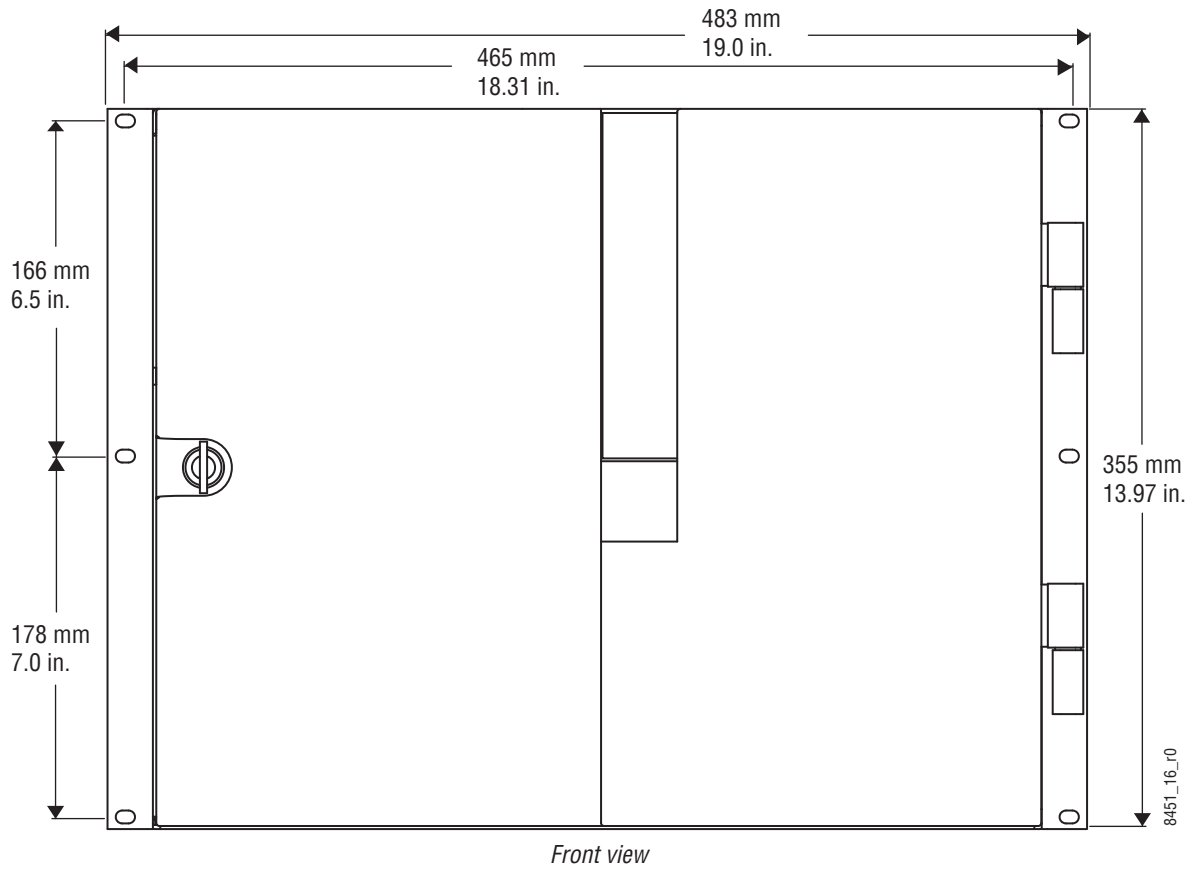
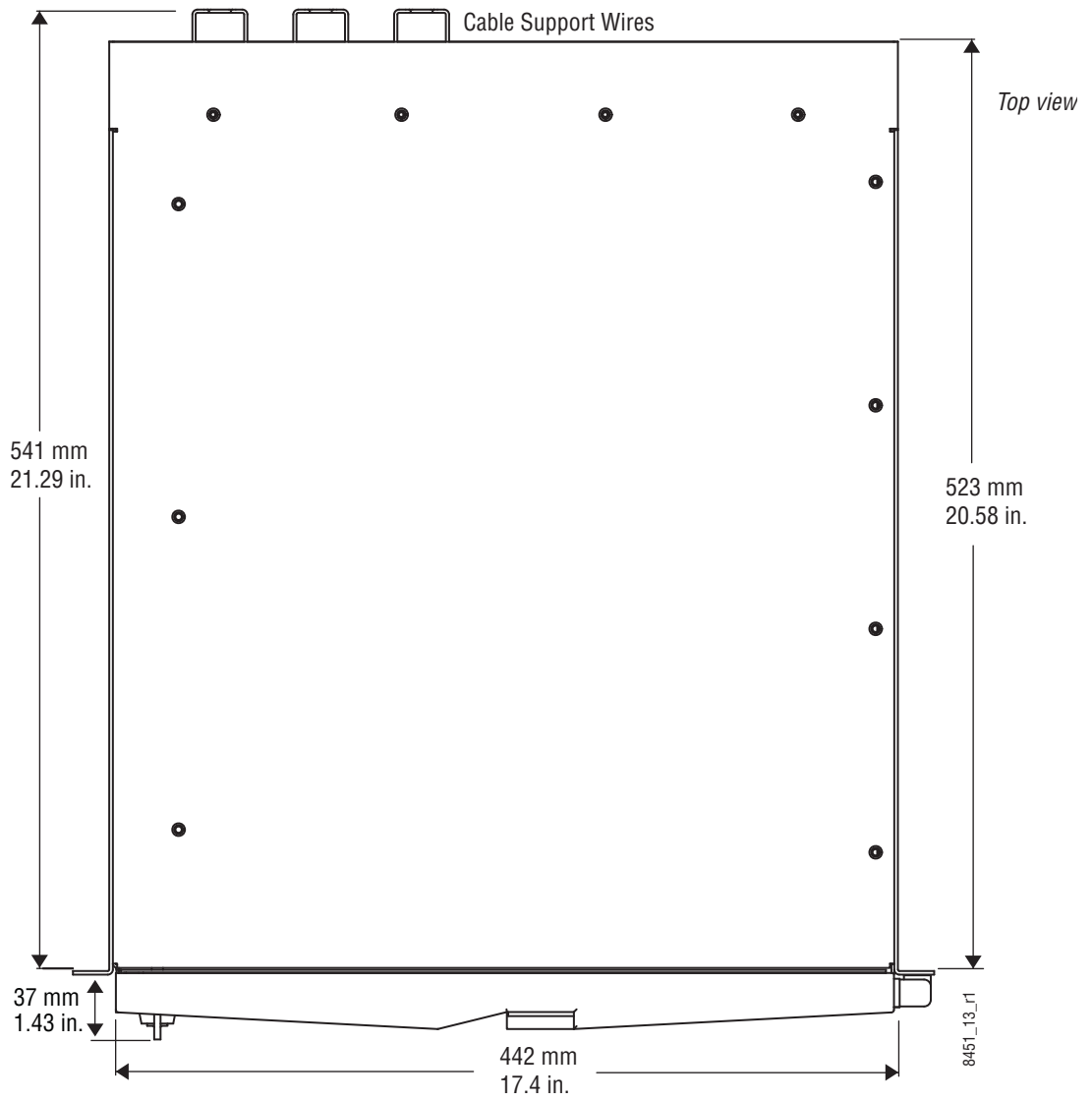
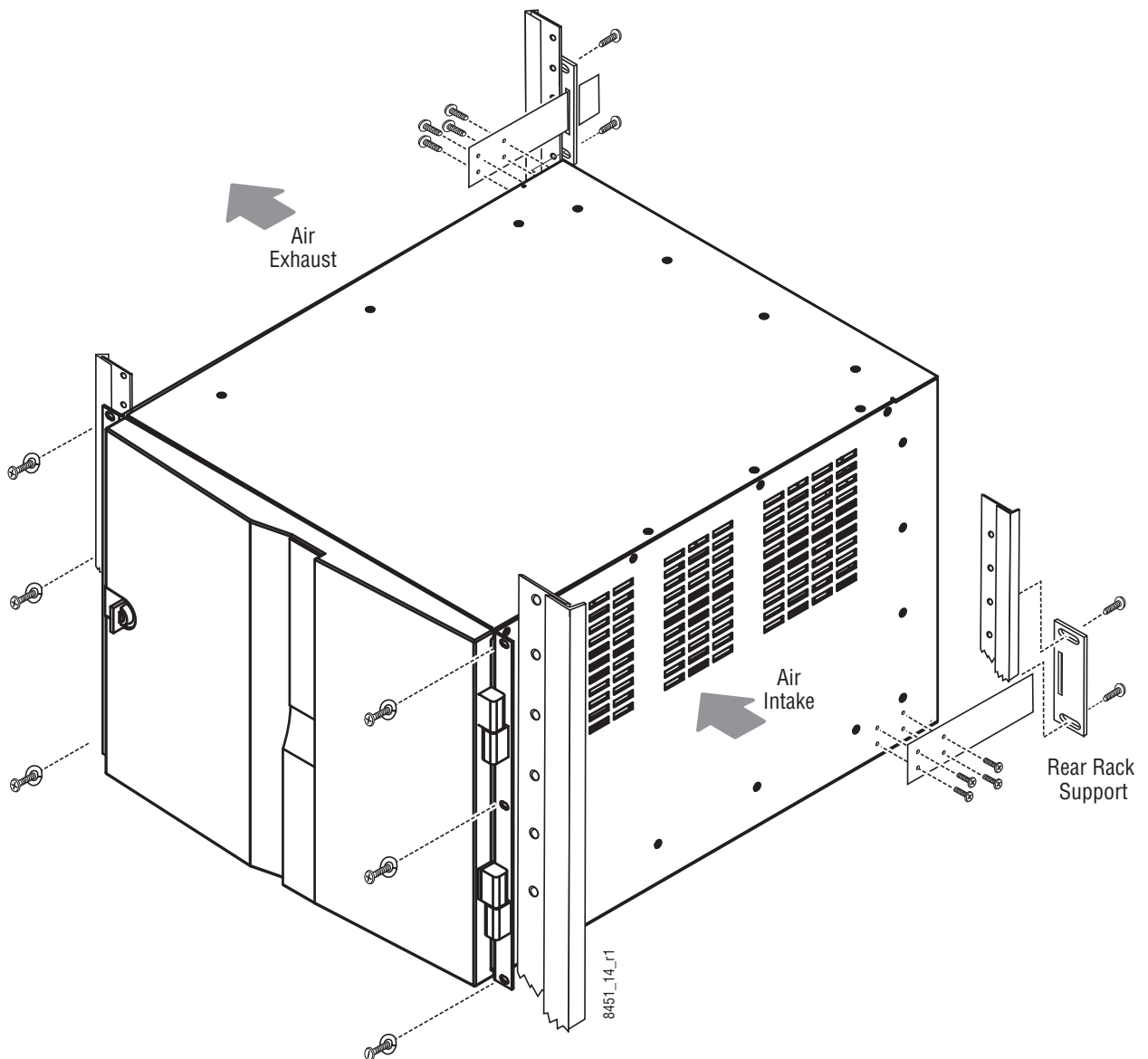


Figure 19. Kayak HD 8 RU Frame Dimensions 2 of 2



8 RU Frame Rack Mounting

Figure 20. Kayak HD 8 RU Frame Dimensions



CAUTION Mounting using only the front rack ears is sufficient for fixed installations. Additional support, like the rear rack support or slide rails, is required for mobile applications.

The Rear Rack support provides additional support and stability for the Kayak HD frame to ensure that it remains horizontal.

Make sure to provide adequate ventilation for the Kayak HD Frame. When installing the frame in the rack, take care that no ventilation holes are blocked. This can prevent cooling air from reaching the frame and cause it to overheat.

There are air intake holes on the right side of the frame (as you face the frame front) and air exhaust holes on the left.

CAUTION A minimum vertical clearance of 7.62 mm (0.3-in.) above the Kayak HD 8 RU frame door is required to remove the door. When installing the Kayak HD 8 RU frame in the rack, take care to leave room for removal of the front door. The front door lifts off vertically and must have sufficient clearance room in order to remove it. If you have equipment mounted too close to the Kayak HD 8 RU Frame, you may not be able to remove the door.

Figure 21. Kayak HD 8RU Frame, Front View with Door Removed

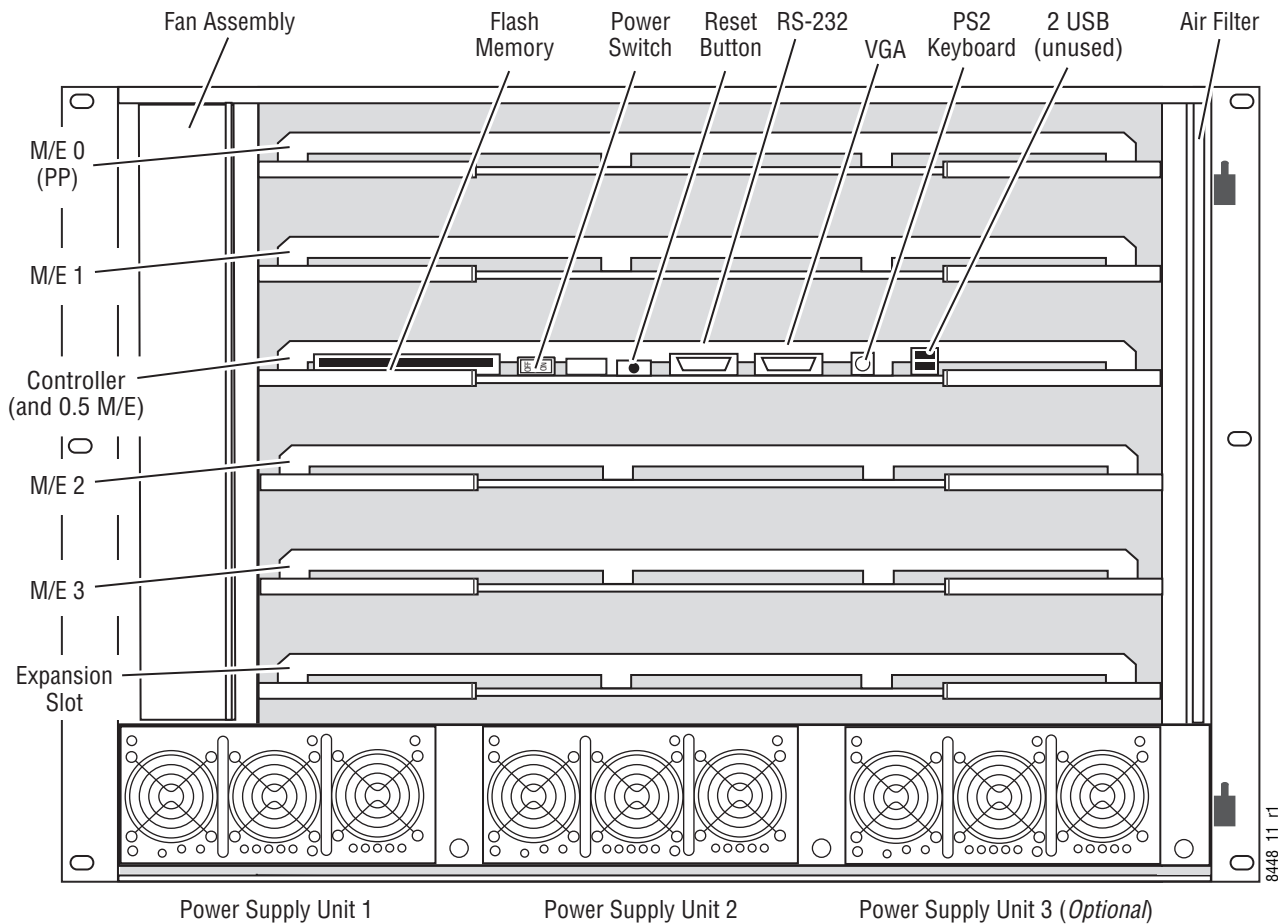
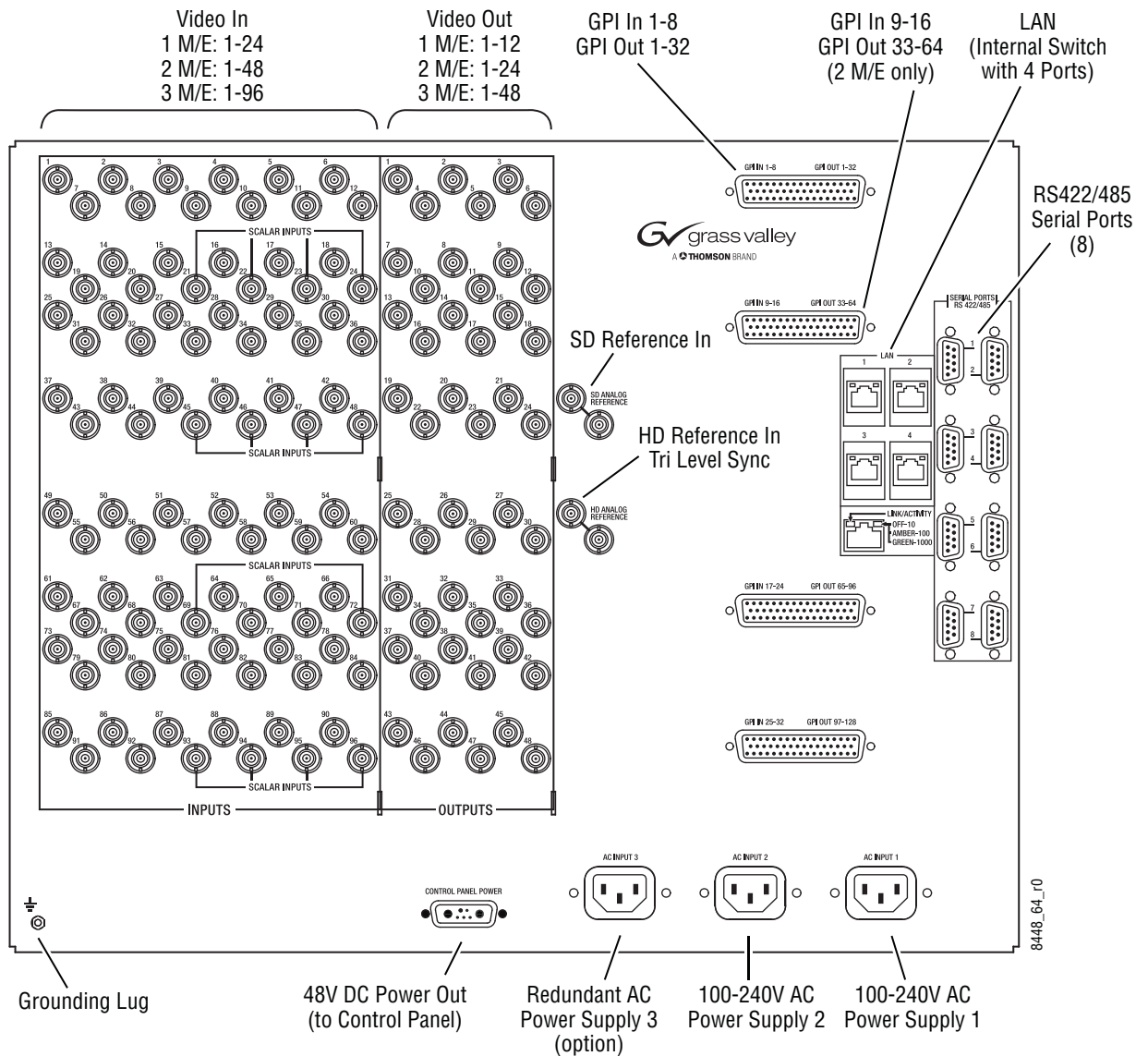


Figure 22. Kayak HD 8RU Frame, Backplane View



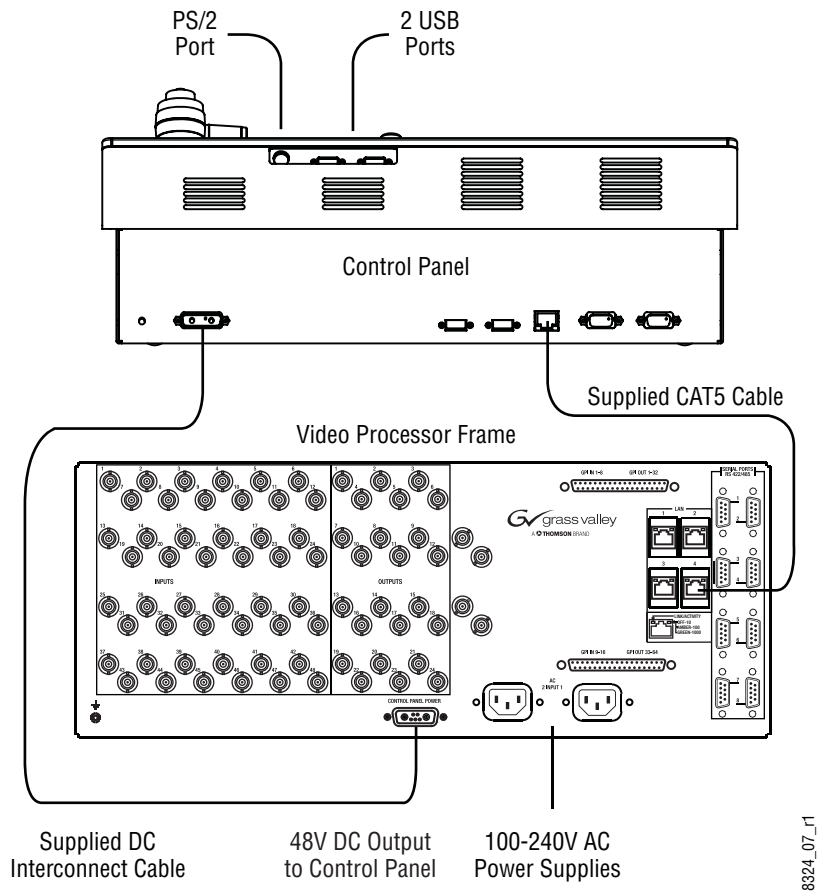
Cabling

The Kayak HD system uses Ethernet, serial, and USB connections. Tally and GPI I/O (General Purpose Interface Input/Output) control are also available. A simple Kayak HD system consisting of a Control Panel and Video Processor frame does not require connection to an external Ethernet Local Area Network (LAN). The video processor frame incorporates an Ethernet switch for this purpose.

There are two AC power supply inputs to the frame. If the redundant power supply option is installed, power can be provided by one or both line cords to two different AC circuits.

Kayak HD 100C Control Cabling

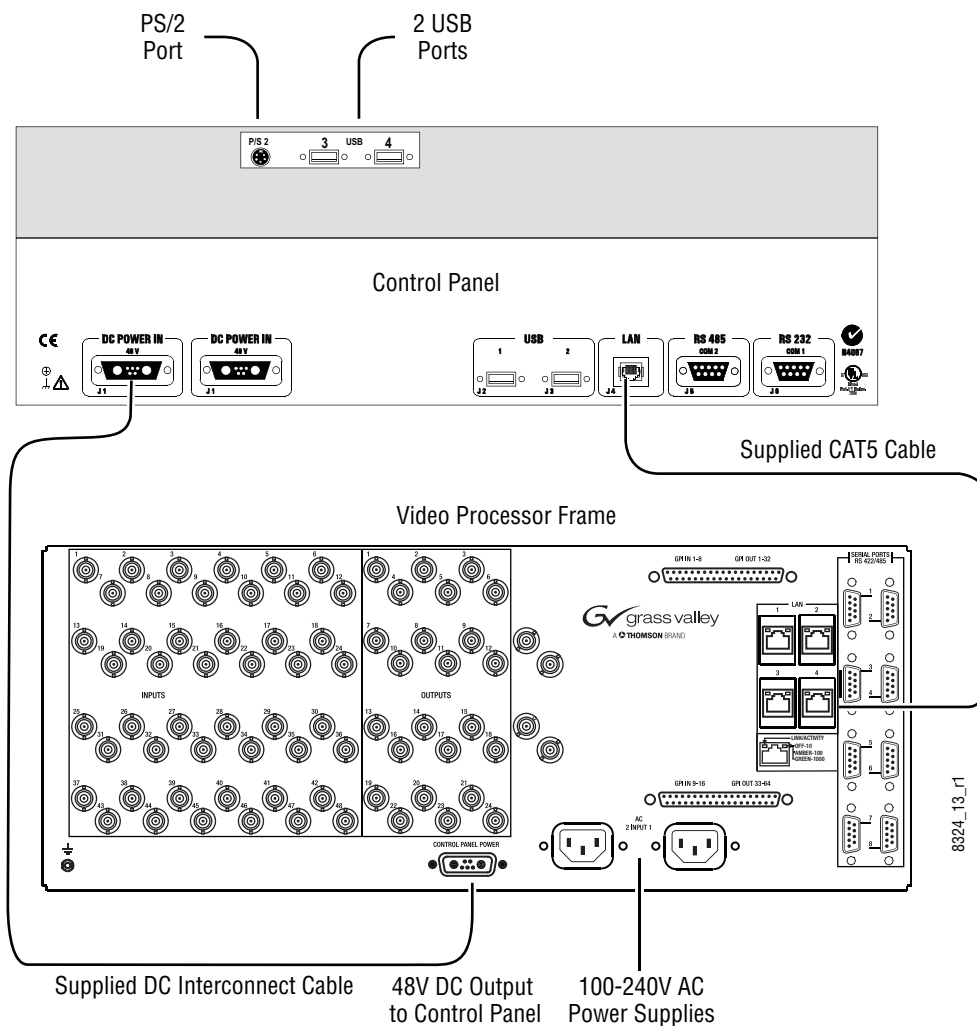
Figure 23. Kayak HD 100C Standard Control Cabling



Kayak HD 150C, 200C, and 200 Panel Control Cabling

Figure 24 shows the basic control cabling for a Kayak HD 150C, 200C, or 200 system.

Figure 24. Kayak HD 150C, 200C, or 200 Standard Control Cabling



The Kayak HD 150C, 200C, or 200 system uses Ethernet, serial, and USB connections. Tally and GPI/O control are also available. A simple Kayak HD 100C system consisting of a Control Panel and Video Processor frame uses point-to-point connections and does not require connection to an external Ethernet Local Area Network (LAN). The video processor frame incorporates an Ethernet switch for this purpose.

There are two AC power supply inputs to the frame. If the redundant power supply option is installed, power can be provided by one or both line cords to two different AC circuits.

Network Cabling

Ethernet Switches and Hubs

A Kayak HD system requires a LAN when components other than a Control Panel and Video Processor frame are connected, or when external network access to a file system is desired. An appropriately-sized Ethernet switch may be required. An existing facility Ethernet switch (not hub) can support Kayak HD if an adequate number of ports are available.

A hub can be used only if there is a need to exceed 328 ft. (100 m) between a Control Panel and Video Processor frame. If a hub is used, connect the hub to the switch via the Uplink port, or through a peer-to-peer crossover cable.

Table 9 details Ethernet specifications. All Ethernet components are to be supplied by the customer except the CAT5 crossover cable provided

Note The supplied crossover cable works with the Kayak HD switcher because the frame has an auto-sensing Ethernet switch.

Table 9. Ethernet Specifications

Cables	Type	10BaseT and 100BaseT compatible. Category 5 cable, 8 conductor twisted pair. The system will work at 10BaseT with reduced performance. 100BaseT components are highly recommended.
	Connectors	RJ-45 male connector at each end of cable.
	Length	10BaseT: 984 ft. (300 m) maximum. 100BaseT: 328 ft. (100 m) maximum. Use hub or switch to exceed maximum cable runs.
Switch	Speed	10/100/1000 Mbps
	Ports	RJ-45 auto-negotiating 10/100 Mbps; number of ports required is dependent upon system size. Frame ports are capable of 1000 Mbps. Using a 1000 Mbps Ethernet switch enhances RAM Recorder transfer speeds.
	Unmanaged	Recommended. Configuration not required, but does not provide remote monitoring capability.
	Managed	May be used. Requires configuration, but offers remote monitoring capability.

CAUTION An existing facility Ethernet switch (not hub) can support Kayak HD if an adequate number of ports are available. Keep your facility network and technical network separate in order to avoid network traffic negatively affecting Kayak HD system operation.

The Kayak HD backplane has four RJ45 Ethernet connectors for its built-in Ethernet switch, each capable of 10/100/1000 Mbps. All Ethernet connectors share the same speed- and direction-sensing features.

One Ethernet connector must connect to the Control Panel. It may go through a switch to make the Control Panel connection, but at least one connector must be connected from the Frame to the Control Panel somehow.

One Ethernet connector may be connected to the Facility LAN if desired. The other two Ethernet connectors may be connected to other devices if needed.

Note If you do connect these extra Ethernet connectors to other devices, please note that these other devices will not communicate if the switcher frame is turned off for any reason. For that reason, it is preferable to connect Ethernet ports coming from the switcher only to other devices that are switcher-related.

Factory Network Settings

The default factory setting for the IP address is

- 192.168.0.70 for the video processor frame
- 192.168.0.73 for the control panel

The Device Setup menu allows to change the IP address. It is only allowed to change the last octet of the IP address (to accommodate Kayak HDs on the same network).

Note In order to integrate Kayak HD devices into an existing network, ask the local network administrator for the subnet mask of the network. Before changing IP addresses always set the subnet masks of the Kayak HD devices to the mask of the local network. If all changes are made and a frame is not visible to the panel, press 'Rescan' in the "Device Control" menu of the panel.

Video Cabling for all Kayak HD Switchers

All Kayak HD system video inputs and outputs are configurable. For cabling configuration flexibility, each external primary input can be mapped to any Kayak HD panel source select button, as can each internal video system source. Any Kayak HD system video signal, such as M/E program, preview, clean feed, or PGM/PST, can be mapped to any output bus to be accessed on a specific connector, or an output bus can act as an auxiliary bus.

Inputs

Non-looping video inputs on the back of the Video Processor frame are numbered 1 through 24 and 25 through 48 on the 4 RU frame. Each accepts a 270 MHz serial digital video signal, or 1.485 Gb. The number of inputs that are active depends on the number of full mix/effects or I/O Expansion modules that are installed in the chassis. There are 24 inputs active for every mix/effects module and expansion module installed.

Outputs

The outputs on the back of the Video Processor frame are numbered 1 through 12 and 13 through 24 on the 4RU frame. All of the outputs carry the same video format, as determined by standard selected and by the reference signals connected. The number of outputs that are active depends on the number of full mix/effects or I/O Expansion modules installed in the chassis. There are 12 outputs active for every mix/effects and expansion module installed.

Reference Input

There are two separate, looping reference input pairs. The upper pair accepts analog 525 or 625 composite video. Burst is not required, but typically facility reference color black is used. Kayak HD can auto-sense whether the reference is 525 or 625 and can change the internal standard accordingly.

The lower looping reference input pair is for HD production and uses analog tri-level sync.

75-ohm termination of one of each of these looping inputs is required, either directly on the adjacent connector or at the end of a daisy chain looping to other equipment.

Any one of the SDI inputs can also be used as reference in the respective standard.

Options

KHD-PSU Internal Redundant Power Supply Option

This option provides redundant power for the Kayak HD video processor chassis and control panel. It slides into an extra power supply slot in the video processor chassis.

Figure 25. KHD-PSU Internal Redundant Power Supply Option



KDD-PSU Power Supply Option

The KDD-PSU option is a 1RU frame unit designed for rack mounting as shown in [Figure 27 on page 41](#). It features a wide range AC power supply providing power for a remotely-mounted Kayak HD Control Panel or for each additional Control Panel connected to the same processor chassis.

Power output is sufficient for two 1 M/E systems or one 2 M/E system.

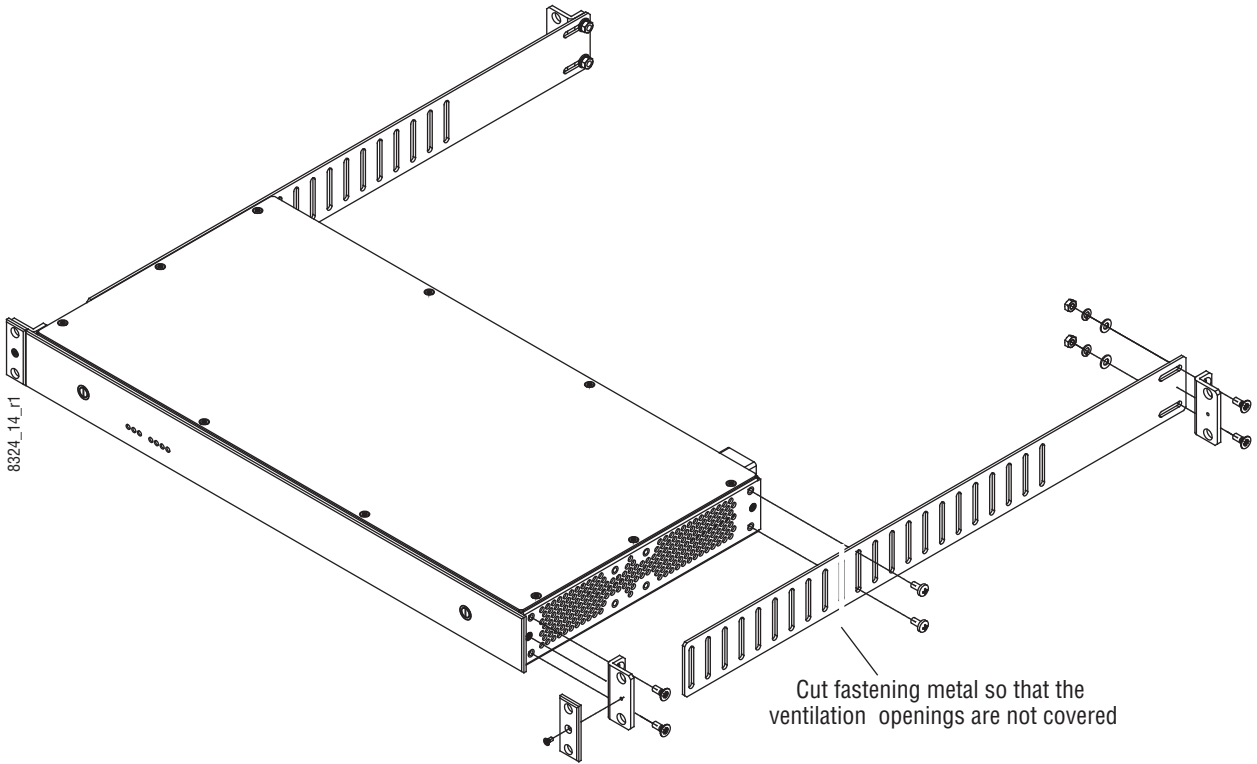
Grass Valley recommends that customers purchase this option if the distance from the Frame to the Control Panel is more than 100 meters.

Figure 26. KDD-PSU



Installation

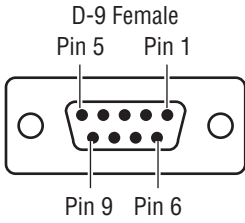
Figure 27. KDD-PSU Rack Installation



Pin Assignments

RS 422/485 Port

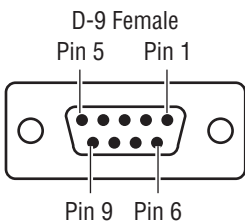
Table 10.

Socket	Pin	Bus Controller	Tributary
 <p>D-9 Female Pin 5 Pin 1 Pin 9 Pin 6</p>	1	Chassis Ground	Chassis Ground
	2	RxA (-)	TxA (-)
	3	TxB (+)	RxB (+)
	4	Signal Ground	Signal Ground
	5	Not used	Not used
	6	Signal Ground	Signal Ground
	7	RxB (+)	TxB (+)
	8	TxA (-)	RxA (-)
	9	Chassis Ground	Chassis Ground

There are 8 RS485 ports that can be used for Machine Control of various devices, or for switcher control by an external controller.

RS 232 Port

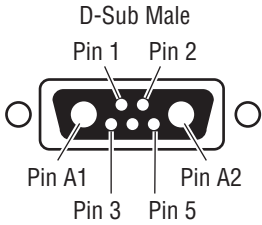
Table 11.

Socket	Pin	Signal
 <p>D-9 Female Pin 5 Pin 1 Pin 9 Pin 6</p>	1	Chassis Ground
	2	Transmit Data
	3	Receive Data
	4	Not used
	5	Signal Ground
	6	Not used
	7	Clear to Send
	8	Request to Send
	9	Not used

There is an RS232 serial port, a keyboard port, and a VGA video output located on front of the Controller Board. These ports are used for diagnostics. If you need to use these ports to diagnose problems with the Kayak HD switcher, please contact your Grass Valley Customer Service Representative.

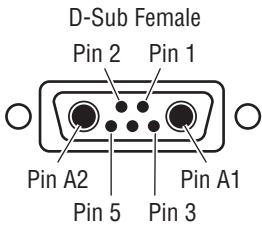
Control Panel DC Power In

Table 12.

Socket	Pin	Signal
	A1	48 V (+)
	A2	48 V (-)
	1	-
	2	-
	3	-
	4	-
	5	-

Frame DC Power Out

Table 13.

Socket	Pin	Signal
	A1	48 V (+)
	A2	48 V (-)
	1	-
	2	-
	3	-
	4	-
	5	-

GPI / Tally Connections

The Kayak HD GPI / Tally system has universal relays that interface source tally and GPI Output information to an external system through the Tally Port connectors. The channels can be assigned in the Setup menu.

Tallies are a source attribute and relays can be assigned to a source when source definitions are defined in the Setup menu during initial system configuration. The nominal rating specification for each relay is 1A, 60 V.

The GPI (General Purpose Interface) and Tally Interface provides a means to transfer commands to and from the switcher to external customer provided equipment. A “one wire per function” parallel hardware connection is used.

Connectors and pins are provided to create a mating connector.

Kayak HD GPI and Tally Interface

The Kayak HD is highly modular and configurable. This document describes various possibilities for tally interconnections.

There are two 50 pin female subminiature 'D' connectors on the rear of the 4 RU Kayak HD frame and four connectors on the rear of the 8 RU Kayak HD frame. Each connector is activated by the presence of a Mix/Effects module installed in the frame. A one M/E switcher (4 RU or 8 RU frame) activates only the first connector. Two M/Es activate two connectors, and so forth, up to four connectors activated by a four M/E system.

GPI inputs and outputs are assigned as follows:

- GPI in 1 - 8 and GPI/Tally out 1 - 32 routed to the first connector.
- GPI in 9 - 16 and GPI/Tally out 33 - 64 routed to the second connector.
- GPI in 17 - 24 and GPI/Tally out 65 - 96 routed to the third connector (8 RU frame only).
- GPI in 25 - 32 and GPI/Tally out 97 - 128 routed to the fourth connector (8 RU frame only).

For pinouts of these connectors refer to the listings in:

- [4 RU and 8RU Frame Tally \(GPI In 1-8, GPI Out 1-32\) on page 49](#)
- [4 RU and 8RU Frame Tally \(GPI In 9-16, GPI Out 33-64\) on page 50](#)
- [8RU Frame Tally \(GPI In 17-24, GPI Out 65-96\) on page 51](#)
- [8RU Frame Tally \(GPI In 25-32, GPI Out 97-128\) on page 52](#)

These four connectors do not share any signals in common other than ground reference and chassis ground. Because of this, some GPI / Tally interconnects may require external common connections between connectors, as explained below.

GPI Inputs

The purpose of the GPI In pins is to provide a stimulus from the customer's equipment to the switcher.

A simple connection to the two connectors (or four in the case of the 8 RU frame) activates the corresponding input. This kind of control is suitable for a connection to a relay contact or to an open-collector output.

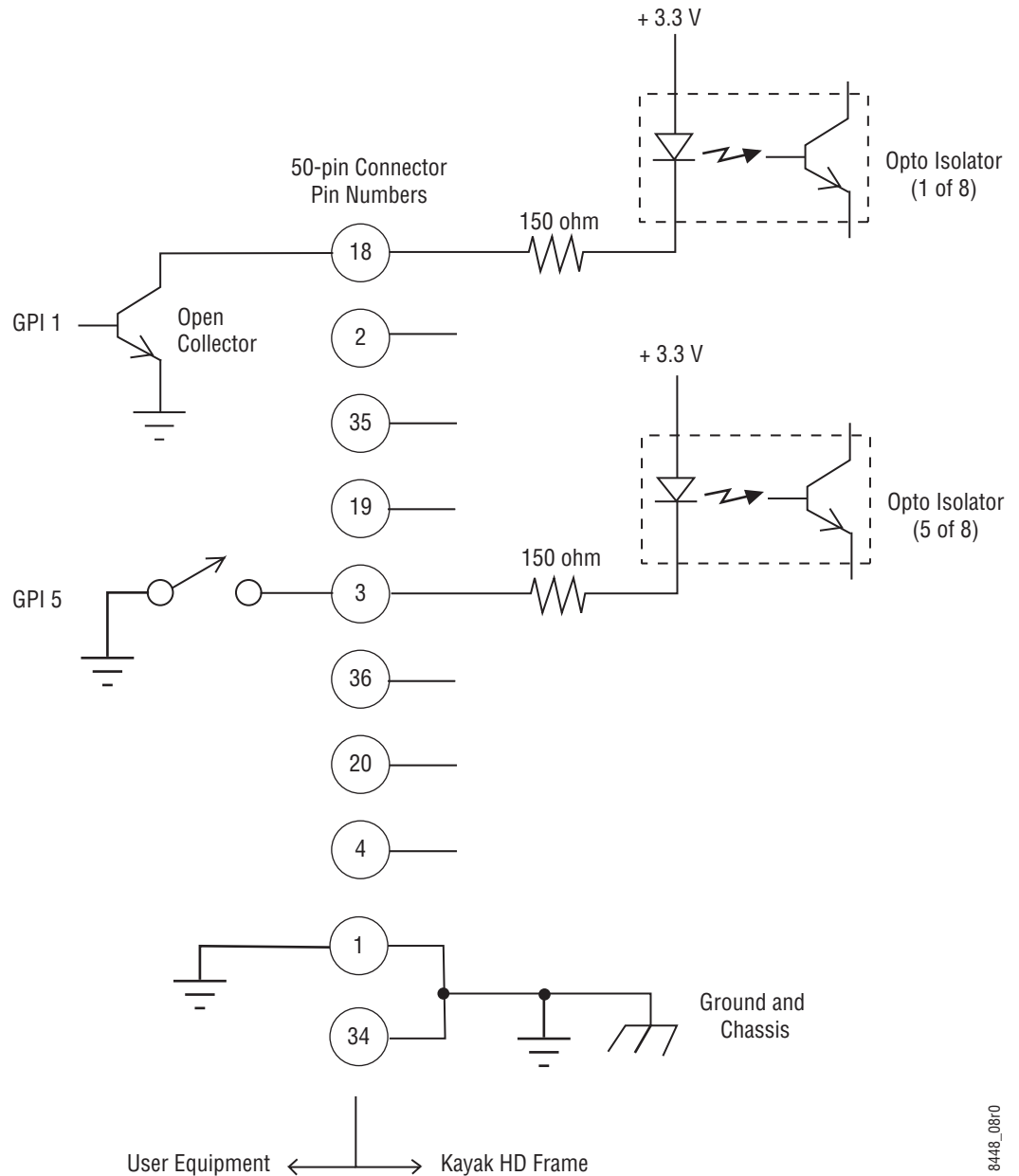
WARNING When connecting to an open-collector output, there is no ground potential isolation between the Video Processor frame and controlling devices.

Since the circuit ground is led out of the device, the cabling has to be shielded for this kind of control. Non-shielded cables may cause EMC and/or ESD problems.

To activate a GPI In you must provide switch closure between a particular GPI In pin and one of the two GPI In Com pins (Pins 1 and 34).

GPI Input Structure

Figure 28. GPI Input Connections (Typical 2 of 8 connections)



Pins 1 and 34 of each of the two (four) connectors are connected to ground. For applications that span across more than one connector, only one ground (common) connection is required.

The function of each GPI input is user assignable. The activation of the function can be programmed to occur on the leading edge or the trailing edge of the closure, or both edges. The switch must be closed for at least one field.

Refer to the [Install Menus](#) section of the *Kayak HD User Manual* for details on setting the input signal activating edge.

Refer to the [Configuration Menu](#) section of the *Kayak HD User Manual* for details on setting the function of a GPI input.

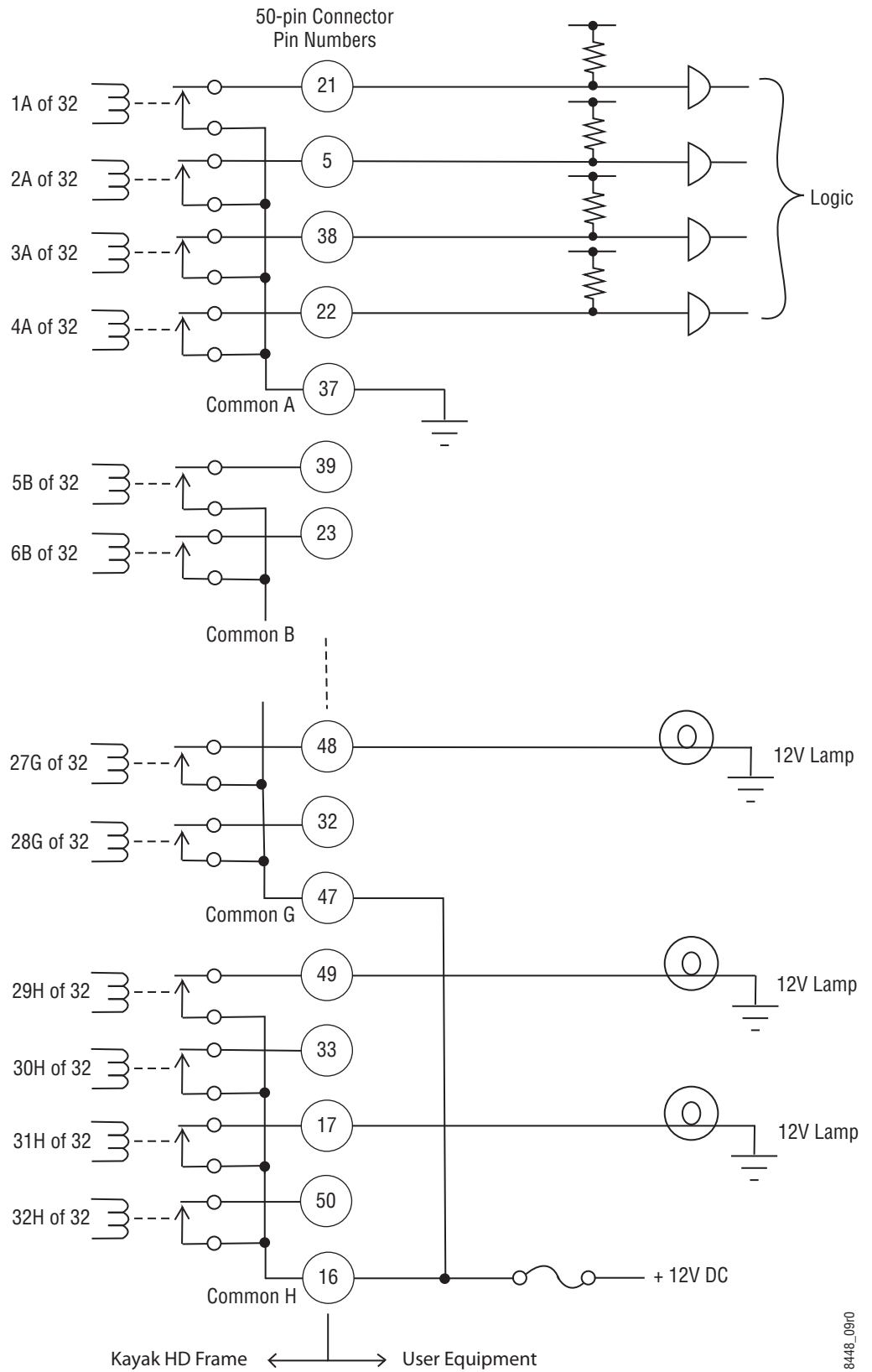
GPI / Tally Outputs

There is a great deal of flexibility in the hardware and programmability of the GPI / Tally outputs.

Outputs are arranged in groups of four. Each group has its own common connection. These are labeled GPI_OUT_COM_A through GPI_OUT_COM_H for the first connector (corresponding to GPI /Tally OUTs 1 - 32). These commons can all be tied together, forming one common bus for all 32 outputs. Alternatively, multiple smaller commons can be constructed to interface with systems that need isolated common connections. This common or isolated bus scheme can extend across multiple connectors. For example, a 4 M/E system could have all commons of all connectors tied together. All 128 relay closures will connect to one common bus. Another case may require two isolated common busses - half of the commons form the first common bus and the other half form the second common bus.

The example in [Figure 29 on page 47](#) shows two common busses. The first four outputs (COMMON A) have the common bus tied to ground. This drives a logic system. The last outputs (COMMON G & COMMON H) have the common bus tied to +12 volts. This drives a tally lamp system.

Figure 29. GPO Tally Connections



8448_0910

Although the diagram above implies mechanical relays, the actual outputs are implemented with solid state relays. Interface specifications are:

Maximum current for any one output: 1 amp AC/DC

Maximum current for any one common: 2 amp AC/DC.

Maximum off (open circuit) voltage between output and common: 60 Volts peak.

Maximum voltage between any point and ground (chassis): 60 Volts peak.

The solid state relays are bidirectional; either polarity voltage can be applied. If the switcher GPI / Tally outputs are used to drive downstream DC relays, be sure to install diodes across the relay coils to clamp inductive spikes. Shielded cable is recommended for the connection from the switcher to the user tally system.

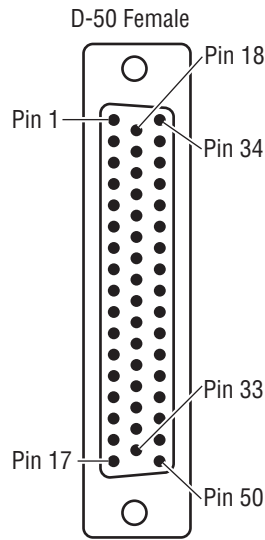
Each output can be programmed for function, steady state or pulse, output polarity, and pulse duration.

Refer to the [Install Menus](#) section of the *Kayak HD User Manual* for details on setting the characteristics of the output signal (steady state, polarity, pulse duration, etc.).

Refer to the [Configuration Menu](#) section of the *Kayak HD User Manual* for details on setting the function of a GPO / Tally output (tally, auto trans, recall register, and so forth).

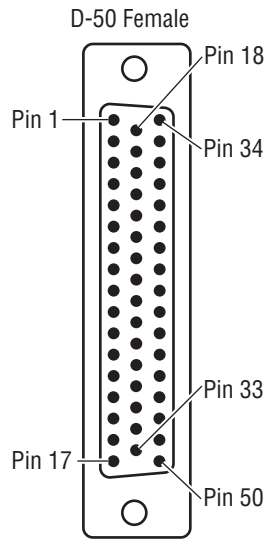
4 RU and 8RU Frame Tally (GPI In 1-8, GPI Out 1-32)

Socket	Ribbon Cable	50-Pin D-Sub	Signal
	1		1 GPIInCom
	2 34		GPIInCom
	3	18	GPIIn1
	4	2	GPIIn2
	5 35		GPIIn3
	6	19	GPIIn4
	7	3	GPIIn5
	8 36		GPIIn6
	9	20	GPIIn7
	10	4	GPIIn8
	11 37		GPIOutComA
	12	21	GPIOut1A
	13	5	GPIOut2A
	14 38		GPIOut3A
	15	22	GPIOut4A
	16	6	GPIOutComB
	17 39		GPIOut5B
	18	23	GPIOut6B
	19	7	GPIOut7B
	20 40		GPIOut8B
	21	24	GPIOutComC
	22	8	GPIOut9C
	23 41		GPIOut10C
	24	25	GPIOut11C
	25	9	GPIOut12C
	26 42		GPIOutComD
	27	26	GPIOut13D
	28	10	GPIOut14D
	29 43		GPIOut15D
	30	27	GPIOut16D
	31	11	GPIOutComE
	32 44		GPIOut17E
	33	28	GPIOut18E
	34	12	GPIOut19E
	35 45		GPIOut20E
	36	29	GPIOutComF
	37	13	GPIOut21F
	38 46		GPIOut22F
	39	30	GPIOut23F
	40	14	GPIOut24F
	41 47		GPIOutComG
	42	31	GPIOut25G
	43	15	GPIOut26G
	44 48		GPIOut27G
	45	32	GPIOut28G
	46	16	GPIOutComH
	47 49		GPIOut29H
	48	33	GPIOut30H
	49	17	GPIOut31H
	50 50		GPIOut32H



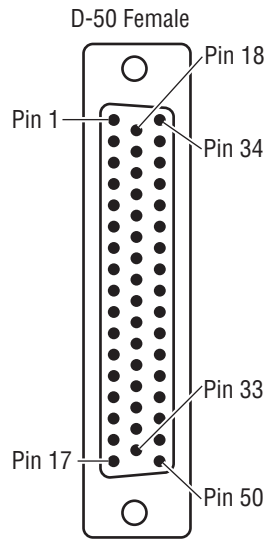
4 RU and 8RU Frame Tally (GPI In 9-16, GPI Out 33-64)

Socket	Ribbon Cable	50-Pin D-Sub		Signal
	1		1	GPIInCom
	2	34		GPIInCom
	3		18	GPIIn9
	4		2	GPIIn10
	5	35		GPIIn11
	6		19	GPIIn12
	7		3	GPIIn13
	8	36		GPIIn14
	9		20	GPIIn15
	10		4	GPIIn16
	11	37		GPIOutComJ
	12		21	GPIOut33J
	13		5	GPIOut34J
	14	38		GPIOut35J
	15		22	GPIOut36J
	16		6	GPIOutComK
	17	39		GPIOut37K
	18		23	GPIOut38K
	19		7	GPIOut39K
	20	40		GPIOut40K
	21		24	GPIOutComL
	22		8	GPIOut41L
	23	41		GPIOut42L
	24		25	GPIOut43L
	25		9	GPIOut44L
	26	42		GPIOutComM
	27		26	GPIOut45M
	28		10	GPIOut46M
	29	43		GPIOut47M
	30		27	GPIOut48M
	31		11	GPIOutComN
	32	44		GPIOut49N
	33		28	GPIOut50N
	34		12	GPIOut51N
	35	45		GPIOut52N
	36		29	GPIOutComP
	37		13	GPIOut53P
	38	46		GPIOut54P
	39		30	GPIOut55P
	40		14	GPIOut56P
	41	47		GPIOutComQ
	42		31	GPIOut57Q
	43		15	GPIOut58Q
	44	48		GPIOut59Q
	45		32	GPIOut60Q
	46		16	GPIOutComR
	47	49		GPIOut61R
	48		33	GPIOut62R
	49		17	GPIOut63R
	50	50		GPIOut64R



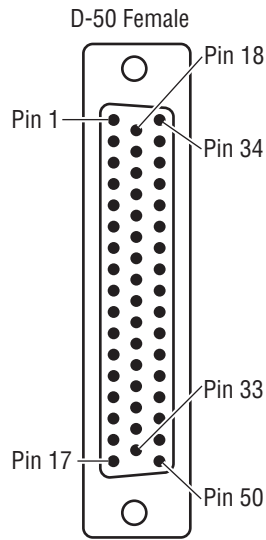
8RU Frame Tally (GPI In 17-24, GPI Out 65-96)

Socket	Ribbon Cable	50-Pin D-Sub	Signal	
	1		1	GPIInCom
	2	34		GPIInCom
	3		18	GPIIn17
	4		2	GPIIn18
	5	35		GPIIn19
	6		19	GPIIn20
	7		3	GPIIn21
	8	36		GPIIn22
	9		20	GPIIn23
	10		4	GPIIn24
	11	37		GPIOutComS
	12		21	GPIOut65S
	13		5	GPIOut6S
	14	38		GPIOut67S
	15		22	GPIOut68S
	16		6	GPIOutComT
	17	39		GPIOut69T
	18		23	GPIOut70T
	19		7	GPIOut71T
	20	40		GPIOut72T
	21		24	GPIOutComU
	22		8	GPIOut73U
	23	41		GPIOut74U
	24		25	GPIOut75U
	25		9	GPIOut76U
	26	42		GPIOutComV
	27		26	GPIOut77V
	28		10	GPIOut78V
	29	43		GPIOut79V
	30		27	GPIOut80V
	31		11	GPIOutComW
	32	44		GPIOut81W
	33		28	GPIOut82W
	34		12	GPIOut83W
	35	45		GPIOut84W
	36		29	GPIOutComX
	37		13	GPIOut85X
	38	46		GPIOut86X
	39		30	GPIOut87X
	40		14	GPIOut88X
	41	47		GPIOutComY
	42		31	GPIOut89Y
	43		15	GPIOut90Y
	44	48		GPIOut91Y
	45		32	GPIOut92Y
	46		16	GPIOutComZ
	47	49		GPIOut93Z
	48		33	GPIOut94Z
	49		17	GPIOut95Z
	50	50		GPIOut96Z



8RU Frame Tally (GPI In 25-32, GPI Out 97-128)

Socket	Ribbon Cable	50-Pin D-Sub		Signal
	1		1	GPIInCom
	2	34		GPIInCom
	3		18	GPIIn25
	4		2	GPIIn26
	5	35		GPIIn27
	6		19	GPIIn28
	7		3	GPIIn29
	8	36		GPIIn30
	9		20	GPIIn31
	10		4	GPIIn32
	11	37		GPIOutComAA
	12		21	GPIOut97AA
	13		5	GPIOut98AA
	14	38		GPIOut99AA
	15		22	GPIOut100AA
	16		6	GPIOutComAB
	17	39		GPIOut101AB
	18		23	GPIOut102AB
	19		7	GPIOut103AB
	20	40		GPIOut104AB
	21		24	GPIOutComAC
	22		8	GPIOut105AC
	23	41		GPIOut106AC
	24		25	GPIOut107AC
	25		9	GPIOut108AC
	26	42		GPIOutComAD
	27		26	GPIOut109AD
	28		10	GPIOut110AD
	29	43		GPIOut111AD
	30		27	GPIOut112AD
	31		11	GPIOutComAE
	32	44		GPIOut113AE
	33		28	GPIOut114AE
	34		12	GPIOut115AE
	35	45		GPIOut116AE
	36		29	GPIOutComAF
	37		13	GPIOut117AF
	38	46		GPIOut118AF
	39		30	GPIOut119AF
	40		14	GPIOut120AF
	41	47		GPIOutComAG
	42		31	GPIOut121AG
	43		15	GPIOut122AG
	44	48		GPIOut123AG
	45		32	GPIOut124AG
	46		16	GPIOutComAH
	47	49		GPIOut125AH
	48		33	GPIOut126AH
	49		17	GPIOut127AH
	50	50		GPIOut128AH



Index

Numerics

- 100 C Control Panel [13](#)
 - Dimensions [14](#)
- 150C, 200C, 200 Control Panels [16](#)
- 150C, 200C, and 200 Control Panels
 - Dimensions [17](#)
 - Panel Control Cabling [35](#)
- 250C, 250, and 300 Control Panels
 - Dimensions [20](#)
- 4 RU Frame [24](#)
 - Dimensions [24](#)
 - Rack Mounting [26](#)
 - Video Processor [27](#)
- 8 RU Frame [29](#)
 - Dimensions [29](#)
 - Rack Mounting [31](#)
 - Video Processor Installation [29](#)

C

- Cabling [34, 52](#)
 - 100C Control Cabling [34](#)
 - Control, 100c [34](#)
 - Control, 150C, 200C, and 200 [35](#)
 - Network [36](#)
- Control Cabling
 - 100C [34](#)
 - 150C, 200C, and 200 [35](#)
- Control Panels
 - 100C, Dimensions [13](#)
 - 150C, 200C, 200 [16](#)
 - 150C, 200C, and 200, Dimensions [17](#)
 - 250C, 250, and 300
 - Dimensions [20](#)
 - Control Cabling [35](#)
- Control Protocols
 - Supported [7](#)

D

- Dimensions
 - 100C Control Panel [14](#)

- 150C, 200C, and 200 Control Panels [17](#)
- 250C, 250, and 300 Control Panels [20](#)
- 4 RU Compact Frame [24](#)
- 8 RU Frame [29](#)
- Surface Mount Cutout (All Panels) [21](#)
- documentation online [4](#)

E

- Ethernet Switches and Hubs [36](#)

F

- Factory Network Settings [37](#)
- FAQ database [4](#)
- Frame
 - Video Processor Installation [24](#)
- frequently asked questions [4](#)

G

- GPI
 - Inputs [44](#)
 - Outputs [46](#)
- GPI Input Structure [45](#)
- GPI Interface [44](#)
- Grass Valley web site [4](#)

H

- Hubs
 - Ethernet [36](#)

I

- Inputs
 - GPI [44](#)
 - Reference [38](#)
 - Video Cabling [37](#)
- Installation
 - 8 RU Video Processor [29](#)
 - KDD-PSU Power Supply Option [41](#)

Video Processor Frame [24](#)

K

Kayak HD

100C Control Cabling [34](#)

100C Control Panel [13](#)

Backplane [36](#)

GPI and Tally Interface [44](#)

Introduction [3](#)

Network Cabling [36](#)

Switcher Models [3](#)

Systems [8](#)

Video Cabling [37](#)

Kayak HD 250C, 250, 300 Control Panels [19](#)

Kayak HD Control Panels [13](#)

KDD-PSU

Power Supply Option [40](#)

Power Supply Option, Installation [41](#)

KHD-PSU

Internal Redundant Power Supply Option [39](#)

N

Network

Cabling [36](#)

Settings, Factory default [37](#)

O

online documentation [4](#)

Options [39](#)

Kayak HD [6](#)

Outputs

GPI [46](#)

Video Cabling [38](#)

P

Panel Mounting Options [21](#)

Pin Assignments [42](#)

Power

KDD-PSU Power Supply Option [40](#)

KHD-PSU Internal Redundant Power Supply
Option [39](#)

Protocols

Supported Control Protocols [7](#)

R

Rack Mounting

4 RU Compact Frame [26](#)

8 RU Frame [31](#)

Instructions [23](#)

Reference

Video Cabling Input [38](#)

S

software download from web [4](#)

Specifications [8](#)

Standard Features

Kayak HD [4](#)

Supported Control Protocols [7](#)

Surface Mount Cutout Dimensions [21](#)

Switcher Models

Kayak HD [3](#)

Switches

Ethernet [36](#)

T

Table Top Use [21](#)

Tally (GPI In 1-8, GPI Out 1-32) [49, 51](#)

Tally (GPI In 9-16, GPI Out 33-64) [50, 52](#)

Tally Interface [44](#)

V

Video Cabling

Inputs [37](#)

Outputs [38](#)

Reference Input [38](#)

Video Processor

4 RU Frame [27](#)

8 RU Frame Installation [29](#)

Frame Installation [24](#)

W

web site documentation [4](#)

web site FAQ database [4](#)

web site Grass Valley [4](#)

web site software download [4](#)

Z

Zodiak [3](#)

