

Instruction Manual

071-0553-01
NOVEMBER 2000

PROFILE PDX 218
DISK EXPANSION CHASSIS

Copyright

Copyright © 2000 Grass Valley Group Inc. All rights reserved. Printed in the United States of America.

This document may not be copied in whole or in part, or otherwise reproduced except as specifically permitted under U.S. copyright law, without the prior written consent of Grass Valley Group Inc., P.O. Box 59900, Nevada City, California 95959-7900

Trademarks

Grass Valley, GRASS VALLEY GROUP, Profile and Profile XP are either registered trademarks or trademarks of Grass Valley Group in the United States and/or other countries. Other trademarks used in this document are either registered trademarks or trademarks of the manufacturers or vendors of the associated products. Grass Valley Group products are covered by U.S. and foreign patents, issued and pending. Additional information regarding

Grass Valley Group's trademarks and other proprietary rights may be found at www.grassvalleygroup.com.

Disclaimer

Product options and specifications subject to change without notice. The information in this manual is furnished for informational use only, is subject to change without notice, and should not be construed as a commitment by Grass Valley Group. Grass Valley Group assumes no responsibility or liability for any errors or inaccuracies that may appear in this publication.

**U.S. Government
Restricted Rights
Legend**

Use, duplication, or disclosure by the United States Government is subject to restrictions as set forth in subparagraph (c)(1)(ii) of the Rights in Technical Data and Computer Software clause at DFARS 252.277-7013 or in subparagraph c(1) and (2) of the Commercial Computer Software Restricted Rights clause at FAR 52.227-19, as applicable. Manufacturer is Grass Valley Group Inc., P.O. Box 59900, Nevada City, California 95959-7900 U.S.A.

Revision Status

Rev Date	Description
December, 1998	Initial Issue. Manual part number 071-0553-00.
November, 2000	Updated Product Support contact information. Part number 071-0553-01.

Grass Valley Group Product Support

You can get technical assistance, check on the status of problems, or report new problems by contacting our Product Support Group.

United States and Canada

Monday–Friday 5:30AM–5:00PM Pacific Time
(800) 547-8949

Europe

Monday–Friday 9:00AM–5:30PM

France	01 45 29 73 00	United Kingdom	01628 405830
Germany	49 221 1791 234	Other	+44 1753 218 777
Italy	02 25086606		

Asia and South America

Australia	02-9888 0100	Japan	81-3-3448-3111
- from overseas	61-2-9888 0100	Korea	82-2-528-5299
Beijing	86-10-62351230	Mexico	52-5-666-6333
	ext. 711	Singapore	65-356-3900
Brazil	55-11-3741-8422	Taiwan	886-2-27571571
Hong Kong	852-2585-6579		

World Wide

24-hour Emergency Hotline (530) 478-4148 (Contract and warranty customers)

World Wide Web <http://www.grassvalleygroup.com/support/>

FTP Site <ftp.grassvalleygroup.com>

Users Group profile-users@grassvalleygroup.com



Contents

	Grass Valley Group Product Support	iii
	General Safety Summary	ix
	Injury Precautions	ix
	Product Damage Precautions	x
	Certifications and Compliances	xi
Chapter 1	Introduction	
	Scope	1-1
	Related Documentation	1-2
	Organization of the Manual	1-2
	Product Description	1-2
	Storage Capacity	1-3
	Product Features	1-4
	Indicators	1-4
	Specifications	1-5
	Definition of Terms Used in Tables	1-5
	Electrical Specifications	1-5
	Mechanical Specifications	1-6
	Environmental Criteria	1-7
Chapter 2	Installing	
	Rack Mounting	2-1
	Mounting the Slides in the Rack	2-2
	Mounting the PDX218	2-5
	Rack Slide Adjustments	2-5
	Making Cable Connections	2-6
	PDX218 SCSI Cable Connections	2-6
	One PDX218 Connected to a Profile System with Two Disk Recorder Boards	2-6
	One PDX218 Connected to a Profile System with One Disk Recorder Board	2-8
	Two PDX218s Connected to a Profile System with Two Disk Recorder Boards	2-9
	Power Connections	2-10
	Power Source	2-10
	Source Power Frequency and Voltage Ranges	2-10
	Creating a File System on the PDX218	2-12
Chapter 3	Service	
	Maintenance	3-2
	Cleaning	3-2
	Exterior	3-2
	Interior	3-2
	Cleaning and Changing the Air Filter	3-3
	Troubleshooting	3-4
	Power On Indicator	3-4
	Disk Activity Indicators	3-5
	System Fault Indicator	3-5
	Fan Fault Indicator	3-5
	Removal and Replacement Procedures	3-6
	Replaceable Parts	3-6
	Removing and Replacing the Front Panel Bezel and Air Filter	3-8
	Removing and Replacing a Disk Drive	3-8
	Removing and Replacing the LED Board	3-10
	Removing and Replacing the LED Cable Assembly	3-11
	Removing and Replacing the Disk Drive LEDs Cable	3-12
	Removing the Top Cover	3-13



Removing the Disk Tray Cover	3-14
Removing and Replacing a SCSI Cable	3-16
Removing and Replacing the SCSI Distribution Board Power Cable	3-18
Removing and Replacing the Switch Cable	3-20
Removing and Replacing the Line In Cable.....	3-21
Removing and Replacing the Power Supply.....	3-22
Removing and Replacing a Fan.....	3-24
Removing and Replacing the SCSI Distribution Board.....	3-26
SCSI-2 Connector Pin-outs	3-28

Figures

1-1 The PDX218 Disk Expansion Chassis.....	1-1
1-2 PDX218 Indicators.....	1-4
1-3 Mechanical Specifications.....	1-6
2-1 Rack Slide Set for Right Side of Chassis and Rack.....	2-2
2-2 Spacing for Mounting Holes in a Rack.....	2-3
2-3 Front Slide Mounting Detail.....	2-4
2-4 Rear Slide Mounting Detail	2-4
2-5 Rack Slide Stop Latch.....	2-5
2-6 PDX 218 SCSI Bus Connectors	2-6
2-7 Connecting the PDX218 to a Profile System with Two Disk Recorder Boards.....	2-6
2-8 Connecting the PDX218 to a Profile System with a Master Disk Recorder Board	2-8
2-9 Connecting Two PDX218s to a Profile System with Master and Slave Disk Recorder Boards.....	2-9
2-10 PDX218 Power Cord Connector and Switch	2-11
3-1 PDX218 Air Filter Removal.....	3-3
3-2 PDX218 Front Panel Indicators	3-4
3-3 Replaceable Parts.....	3-7
3-4 Lowering the Front Panel.....	3-8
3-5 PDX218 Disk Drive Caddie and Disk Drive Removal	3-9
3-6 PDX218 LED Board and Cable Removal	3-10
3-7 Disk Drive LEDs Cable Removal	3-12
3-8 PDX218 Top Cover Removal	3-13
3-9 PDX218 Disk Tray Cover Removal	3-15
3-10 Removal of a SCSI Cable	3-16
3-11 Removal of the SCSI Distribution Board Power Cable	3-18
3-12 Removal of the Switch and Line In Cables	3-20
3-13 PDX218 Power Supply Removal	3-22
3-14 PDX218 Fan Removal.....	3-24
3-15 PDX218 SCSI Distribution Board Removal	3-26
3-16 SCSI-2 Connector.....	3-28

Tables

1-1 PDX218 Storage Capacity Estimates (Eight 18GB disk drives)	1-3
1-2 Power Source	1-5
1-3 PDX218 Mechanical Specifications	1-6
1-4 Environmental Criteria	1-7
2-1 Power Cords for the PDX218 Disk Expansion Chassis	2-11
3-1 PDX218 Replaceable Part List	3-6
3-2 SCSI-2 Connector Pin-outs	3-29

General Safety Summary

Review the following safety precautions to avoid injury and prevent damage to this product or any products connected to it.

Only qualified personnel should perform service procedures.

While using this product, you may need to access other parts of the system. Read the *General Safety summary* in other system manuals for warnings and cautions related to operating the system.

Injury Precautions

- | | |
|--|--|
| Use Proper Power Cord | To avoid fire hazard, use only the power cord specified for this product. |
| Ground the Product | This product is grounded through the grounding conductor of the power cord. To avoid electric shock, the grounding conductor must be connected to earth ground. Before making connections to the input or output terminals of the product, ensure that the product is properly grounded. |
| Do Not Operate Without Covers | To avoid electric shock or fire hazard, do not operate this product with covers or panels removed. |
| Use Proper Fuse | To avoid fire hazard, use only the fuse type and rating specified for this product. |
| Do Not operate in Wet/Damp Conditions | To avoid electric shock, do not operate this product in wet or damp conditions. |
| Do Not Operate in an Explosive Atmosphere | To avoid injury or fire hazard, do not operate this product in an explosive atmosphere. |
| Avoid Exposed Circuitry | To avoid injury, remove jewelry such as rings, watches, and other metallic objects. Do not touch exposed connections and components when power is present. |



Product Damage Precautions

Use Proper Power Source

Do not operate this product from a power source that applies more than the voltage specified.

Provide Proper Ventilation

To prevent product overheating, provide proper ventilation.

Do Not Operate With Suspected Failures

If you suspect there is damage to this product, have it inspected by qualified service personnel.

Regulatory Summaries

Certifications and Compliances

Canadian Certified Power Cords

Canadian approval includes the products and power cords appropriate for use in the North America power network. All other power cords supplied are approved for the country of use.

FCC Emission Control

This equipment has been tested and found to comply with the limits for a Class A digital device, pursuant to Part 15 of the FCC Rules. These limits are designed to provide reasonable protection against harmful interference when the equipment is operated in a commercial environment. This equipment generates, uses, and can radiate radio frequency energy and, if not installed and used in accordance with the instruction manual, may cause harmful interference to radio communications. Operation of this equipment in a residential area is likely to cause harmful interference in which case the user will be required to correct the interference at his own expense. Changes or modifications not expressly approved by Grass Valley Group can affect emission compliance and could void the user's authority to operate this equipment.

Canadian EMC Notice of Compliance

This digital apparatus does not exceed the Class A limits for radio noise emissions from digital apparatus set out in the Radio Interference Regulations of the Canadian Department of Communications.

Le présent appareil numérique n'émet pas de bruits radioélectriques dépassant les limites applicables aux appareils numériques de la classe A prescrites dans le Règlement sur le brouillage radioélectrique édicté par le ministère des Communications du Canada.

EN55022 Class A Warning

For products that comply with Class A. In a domestic environment this product may cause radio interference in which case the user may be required to take adequate measures.

Certification

Category	Standard
Safety	<i>Designed/tested for compliance with:</i> UL1950 - Safety of Information Technology Equipment, including Electrical Business Equipment (Third edition, 1995) IEC 950 - Safety of Information Technology Equipment, including Electrical Business Equipment (Second edition, 1991, Amendments 1, 2, 3, and 4) CAN/CSA C22.2, No. 950-95 - Safety of Information Technology Equipment, including Electrical Business Equipment EN60950 - Safety of Information Technology Equipment, including Electrical Business Equipment



Introduction

Scope

This is the Instruction Manual for the Grass Valley Group PDX218, Disk Expansion Chassis (Figure 1-1). The manual consists of:

- A description of the PDX218.
- Installation procedures.
- Maintenance procedures.
- Troubleshooting.
- Removal and replacement procedures.

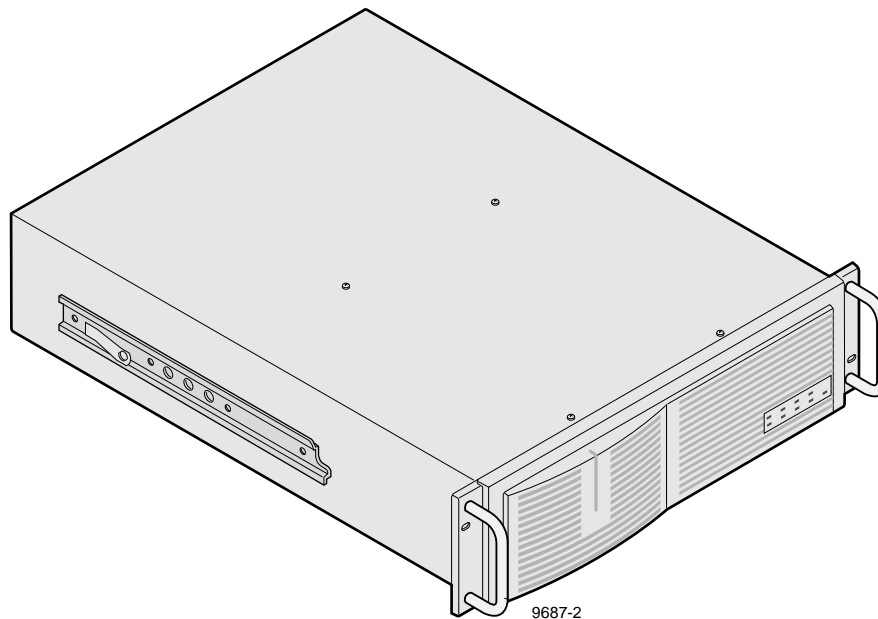

Figure 1-1. The PDX218 Disk Expansion Chassis



Related Documentation

Profile PDR 200 & PDR 300 Installation Manual

Profile Family User Manual

Profile System Software Release Notes

Organization of the Manual

This instruction manual consists of the chapters identified and described below.

Chapter 1 - Introduction: This chapter describes the contents of the manual and the PDX218 chassis. It includes physical and electrical specifications and environmental criteria.

Chapter 2 - Installation: This chapter describes the physical installation of the PDX218 including initial power-on. It includes configuration information.

Chapter 3 - Service: This chapter consists of maintenance information, troubleshooting procedures, and removal and replacement procedures. The chapter includes a list of Field Replaceable Units (FRUs) and pin-outs for the rear panel SCSI-2 connector.

Product Description

The PDX218 Disk Expansion Chassis provides external storage for the Profile Video File Server. The PDX218 contains eight 18GB Ultra-SCSI disk drives on two SCSI buses; four disk drives on each bus. The two SCSI buses can be connected together, using one of the external SCSI cables provided, placing all eight disk drives on a single SCSI bus. This design provides the flexibility to operate the PDX218 with different Profile Video File Server configurations.

The Profile Disk Utility, included with Profile system software, is used to configure the PDX218 for operation as part of the Profile system. For more information about the Profile Disk Utility refer to “Using the Profile Disk Utility” in the *Profile Family User Manual*.

Storage Capacity

The Profile Video File Server storage capacity is determined by the number of disk drives in the system and the selected video data rate used to record the video signal. The Profile Video File Server storage space can be expanded by adding one or two PDX218 Disk Expansion Chassis containing eight 18GB disk drives each.

Table 1-1 shows storage capacity estimates at selected video data rates for a single PDX218 containing eight 18GB disk drives

All Profile applications software allows you to select the video data rate used to record the video signal. For more information about setting the video data rate, refer the appropriate sections of the *Profile Family User Manual*.

Table 1-1. PDX218 Storage Capacity Estimates (Eight 18GB disk drives)

PDR200 JPEG Data Rate		PDR300 MPEG2 Data Rate			
48Mb/s	24Mb/s	24Mb/s	18Mb/s	15Mb/s	
100KB/fld	50KB/fld	100KB/frm	80KB/frm	70/KB/frm	525/50
120KB/fld	60KB/fld	120KB/frm	90KB/frm	80KB/frm	625/50
5.4 hrs	9.9 hrs	10.2 hrs	13 hrs	15 hrs	

Storage estimates include 4 channels of audio and 2 channels of timecode. Adding 4 more channels of audio adds approximately 3Mb/s to the total data rate.



Product Features

Features of the PDX218 are:

- Contains its own power supply and connection to source power.
- Mounts on rack slides for installation in a standard equipment rack.
- Control interface and media transfers from and to the Profile system are through SCSI-2 cables connected to the rear panel (see Chapter 2, *Installation*).
- Front panel indicators.

Indicators

The following describes the indicators on the PDX218 front panel (see Figure 1-2).

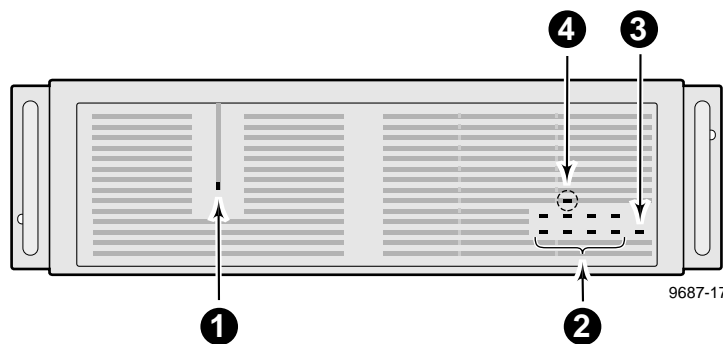

Figure 1-2. PDX218 Indicators

- ❶ Power indicator; green LED lighted when the power switch on the rear panel is On.
- ❷ Disk Activity indicators; two banks of four green LEDs show disk activity. Each bank corresponds to a SCSI bus with four disk drives. Mapped to the physical location of each hard disk drive in the chassis, the LEDs flash when activity occurs on the associated disk. A LED that never flashes on or remains on may indicate a problem with the associated disk.
- ❸ System Fault indicator; red LED off during normal operation. Lights to indicate either a terminal power failure or (with 4 below lighted) a fan failure.
- ❹ Fan Fault indicator (behind the front panel bezel and only visible with the bezel removed); red LED off during normal operation. Lights (along with 3 above) to indicate a fan failure.

Specifications

The following tables list the electrical and physical specifications and environmental criteria for the PDX218.

Definition of Terms Used in Tables

The following terms apply to the PDX218 as they appear in the following tables.

Specification - A document or a section of a document that lists and describes characteristics and performance requirements of equipment and certain program material.

REQUIREMENT: (Performance Requirement) - A statement that defines a characteristic usually in limit form.

SUPPLEMENTAL DATA: - Statements that explain performance requirements or provide performance information. These are not considered to be statements of guaranteed performance and are not ordinarily supported by a performance check procedure.

Electrical Specifications

Table 1-1 lists the electrical specifications for the PDX218.

Table 1-2. Power Source

Specifications	Description
Electrical Rating	<i>Requirement:</i> 100 -240V, 50/60 Hz, 3A maximum
Supply Type	<i>Supplemental Data:</i> Single Phase
Supply Connection	<i>Supplemental Data:</i> Detachable cord set
Power Consumption	<i>Supplemental Data:</i> <300 VA



Mechanical Specifications

Figure 1-3 shows the dimensions of the PDX218 and Table 1-2 lists and the mechanical specifications.

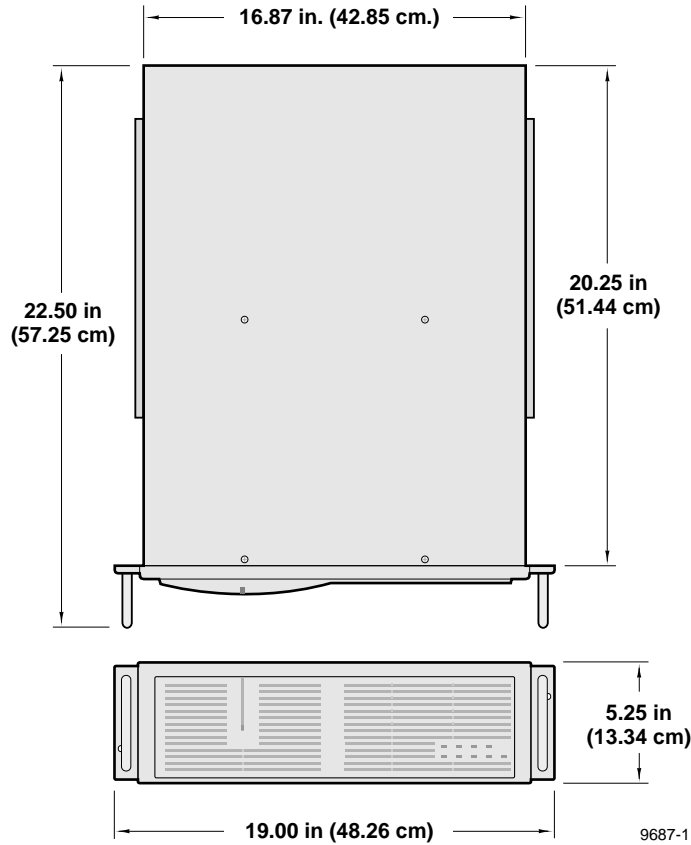

Figure 1-3. Mechanical Specifications

Table 1-3. PDX218 Mechanical Specifications

Specification	Description	
Dimensions	<i>Requirement:</i>	Height: 5.250 inches (13.335 centimeters) Width: 19.000 inches (48.260 centimeters) Depth: 22.500 inches (57.150 centimeters)
Weight	<i>Requirement:</i>	Net: 51.5 pounds (23.360 kilograms) Shipping: 71 pounds (32.205 kilograms)

Environmental Criteria

Table 1-4. Environmental Criteria

Characteristics	Description
Operating Temperature	<i>Requirement:</i> 10° to 40°C (+50° to 104°F)
Storage Temperature	<i>Requirement:</i> -40° to 60°C (-40° to 140°F)
Operating Altitude	<i>Requirement:</i> To 10,000 feet (3048 meters) <i>Supplemental Data:</i> IEC 950 compliant to 2000 meters
Storage Altitude	<i>Requirement:</i> To 40,000 feet (12,192 meters)
Mechanical Shock	Military Specification: Mil-T-28800D, Class 6 (Non-Operating Only)
Transportation	<i>Requirement:</i> Qualified under NSTA Test Procedure 1A, Category II (18 inch drop)
Equipment Type	<i>Supplemental Data:</i> Information Technology
Equipment Class	<i>Supplemental Data:</i> Class I
Installation Category	<i>Requirement:</i> Category II Local level mains, appliances, portable equipment
Pollution Degree	<i>Requirement:</i> Level 2 operating environment, indoor use only
Humidity	<i>Requirement:</i> Operating 8% - 90% Non-Operating 8% - 90% Maximum Wet Bulb Temperature 29° operating <i>Supplemental Data:</i> Do not operate with visible moisture on the circuit boards



This chapter describes the physical installation of your PDX218 and configuring it for use with your Profile Video File Server. The information includes:

- Mounting the PDX218 in the equipment rack.
- Making PDX218 rear panel cable connections.
- Turning power On.
- Making a file system on the PDX218.

Rack Mounting

The PDX218 installs in a standard 19-inch equipment rack. Rack slides allow the PDX218 to slide in and out without having to remove it from the rack. However, if the rack does not already have rack slides installed, or if the slides are not correctly positioned, you will have to use those shipped with the PDX218.

When determining the location of the PDX218 in the rack, bear in mind that the unit weighs approximately 51.5 pounds. Observe the following warnings:



WARNING: To prevent injury, two people are required to lift the PDX218. It is too heavy for one person to install in the rack.



WARNING: To prevent serious injury, insure that the rack is anchored to the floor so that it cannot tip over when the PDX218 is extended out of the rack.



Mounting the Slides in the Rack

Figure 2-1 shows the components of a right-hand rack slide set. Note that the chassis section is already attached to the PDX218. When mounting rack slides in the equipment rack, bear in mind that the PDX218 occupies 3 RUs.

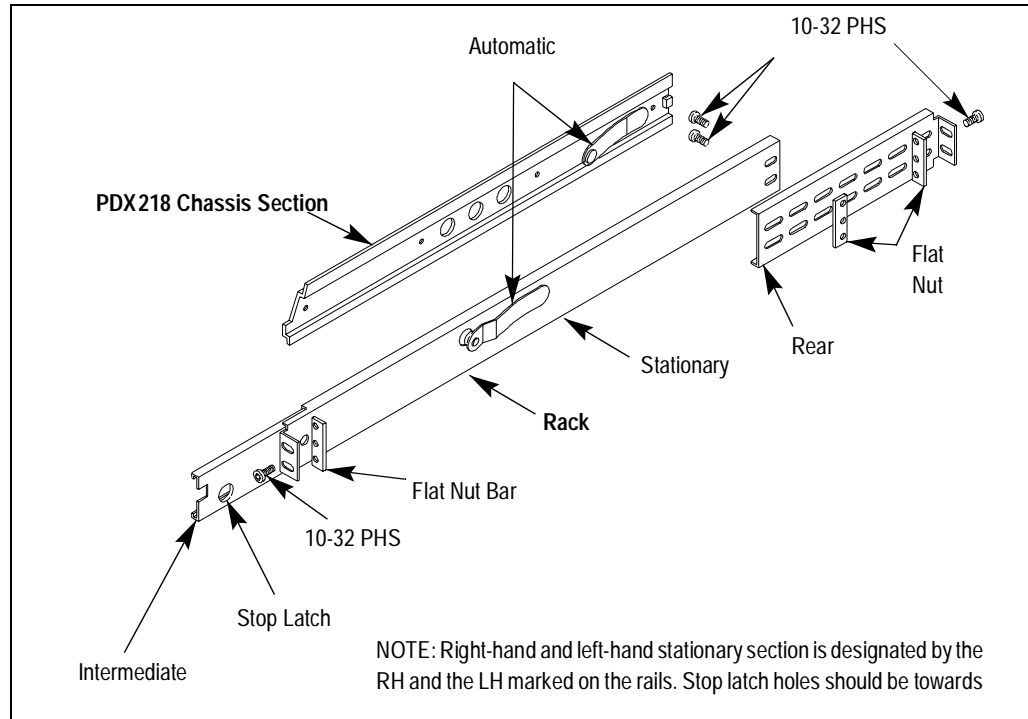

Figure 2-1. Rack Slide Set for Right Side of Chassis and Rack

Locate the proper rack holes as shown in Figure 2-2. Notice that the hole spacing can vary with the rack type. When mounting the slides in racks with EIA spacing, make sure that the slides are attached to the 0.5-inch spaced holes.

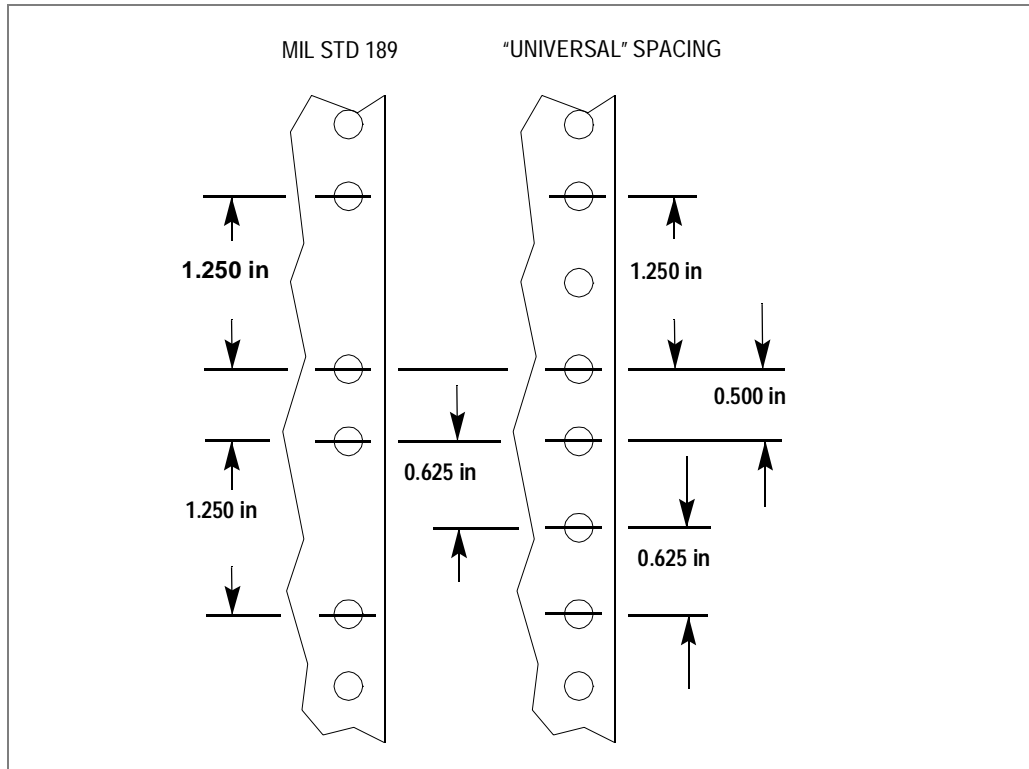

Figure 2-2. Spacing for Mounting Holes in a Rack



Mount the slides using the enclosed hardware as shown in Figure 2-2. Figures 2-3 and 2-4 show the front and rear slide mounting details for both deep and shallow racks. Make sure the stationary sections are horizontally aligned and are level as well as parallel to each other.

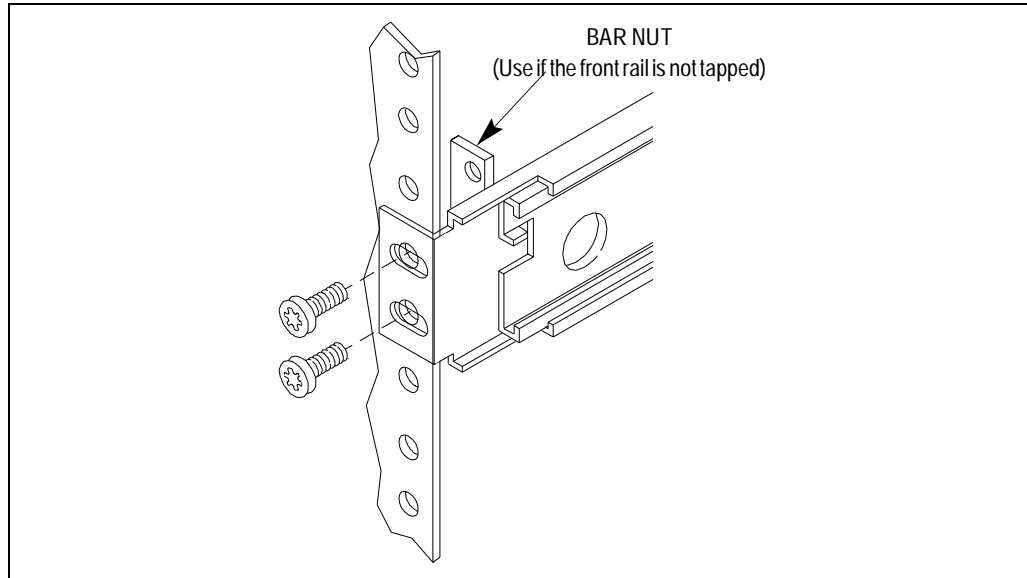

Figure 2-3. Front Slide Mounting Detail

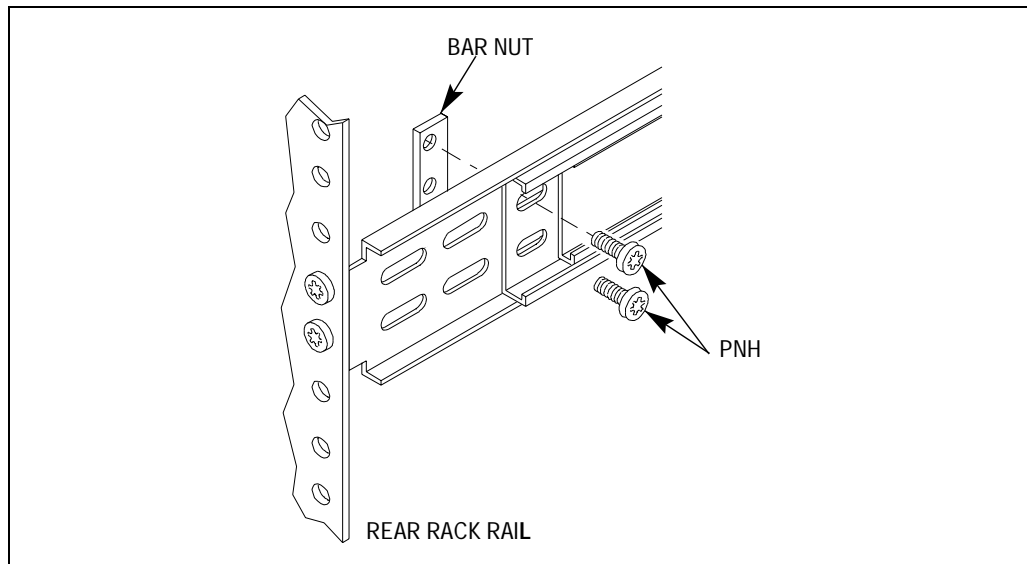

Figure 2-4. Rear Slide Mounting Detail

Mounting the PDX218

In addition to having room to make cable connections, the PDX218 requires six inches (15.25 cm) of clearance behind the rear panel for connectors and cable bends. Adequate air flow must also be assured around the chassis to provide sufficient cooling. (Operating ambient temperature will affect the amount of air circulation required to keep the PDX218 within its temperature limitations.)

1. Pull the slide-out section to the fully extended position. See Figure 2-5.



WARNING: To prevent injury, two people are required to lift the PDX218. The PDX218 is too heavy for one person to install in the rack.



WARNING: To prevent serious injury, insure that the rack is anchored to the floor so that it cannot tip over when the PDX218 is extended out of the rack.

2. Insert the ends of the chassis sections into the slide-out sections.
3. Push the chassis toward the rack until the chassis sections lock into the intermediate sections.
4. Press the stop latches in the intermediate sections and push the chassis toward the rack until the latches snap into their holes.

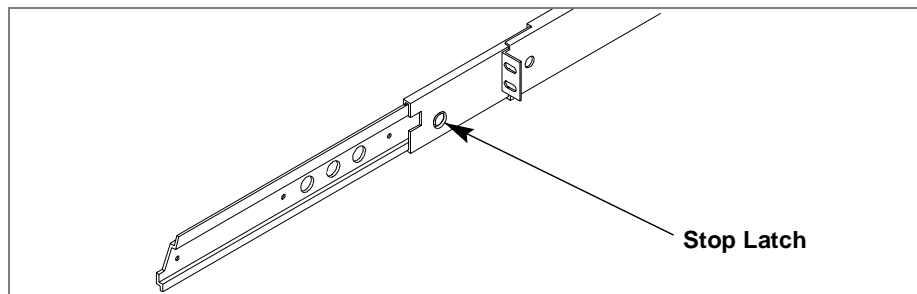

Figure 2-5. Rack Slide Stop Latch

5. Again, press the stop latches and push the cabinet fully into the rack.
6. Insert and tighten the front panel retaining screws.

Rack Slide Adjustments

After installation, binding may occur if the slides are not properly adjusted. To adjust the slides:

1. Slide the chassis out approximately 10 inches.
2. Slightly loosen the mounting screws holding the slides to the front of the rack and allow the slides to seek an unbound position.
3. Tighten the mounting screws and check the slides for smooth operation by sliding the chassis in and out of the rack several times.
4. Tighten the front panel retaining screws once the cabinet is in place within the rack to complete the installation.



Making Cable Connections

All cables connect to the PDX218 SCSI Bus 1 and SCSI Bus 2 connectors on the rear panel as shown in Figure 2-6.

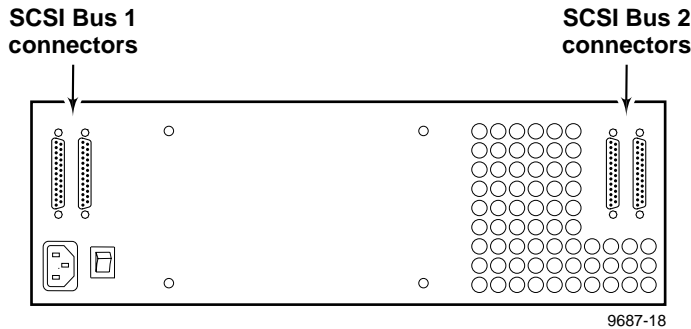

Figure 2-6. PDX 218 SCSI Bus Connectors

PDX218 SCSI Cable Connections

The following examples show SCSI cable connections between the PDX218 and the Profile Video File Server.

NOTE: After making SCSI connections, you must use the Profile Disk Utility software to create a file system on the PDX218 disk drives before it can operate as part of the Profile system. See “Creating a File System on the PDX218” on page 2-12.

One PDX218 Connected to a Profile System with Two Disk Recorder Boards

Figure 2-7 shows a PDX218 connected to a Profile system with Master and Slave Disk Recorder Boards installed. The location of the Disk Recorder Boards may be different than shown in Figure 2-7. To locate the Disk Recorder boards in your system, see the rear panel board slot labels.

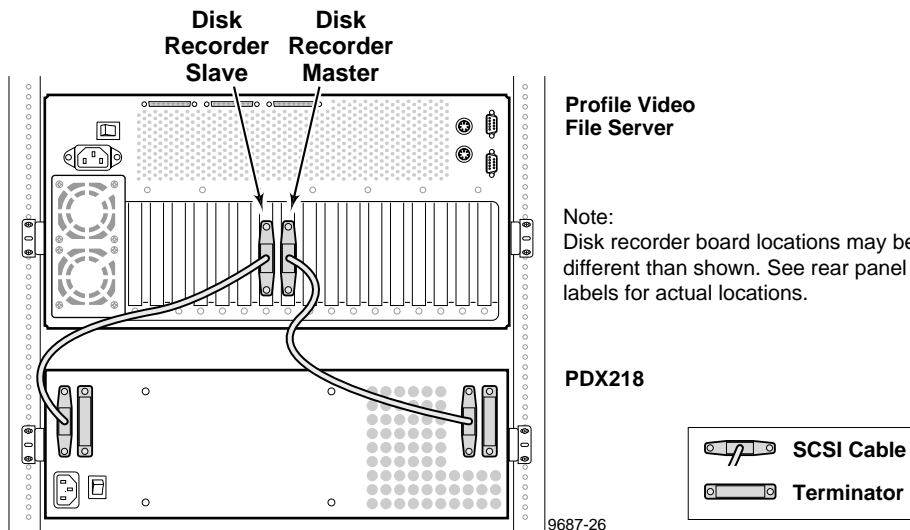

Figure 2-7. Connecting the PDX218 to a Profile System with Two Disk Recorder Boards

To make SCSI cable connections refer to Figure 2-7 and:

1. Connect a SCSI cable from the PDX218 SCSI Bus 2 connector to the Profile system rear panel connector in the slot labeled DISK RECORDER Master.
2. Connect a SCSI cable from the PDX218 SCSI Bus 1 connector to the Profile system rear panel connector in the slot labeled DISK RECORDER Slave.
3. Connect SCSI Terminators to the unused SCSI Bus 1 and SCSI Bus 2 connectors on the PDX218.

The PDX218 connections shown in Figure 2-7 provide four 18GB disk drives to the SCSI A bus and four 18GB disk drives to the SCSI C bus on the Profile system (or SCSI A & B bus on a PDR100).



One PDX218 Connected to a Profile System with One Disk Recorder Board

Figure 2-8 shows a PDX218 connected to a Profile system with only a Master Disk Recorder board installed. The location of the Master Disk Recorder board may be different than shown in Figure 2-8. To locate the Master Disk Recorder board in your system, see the rear panel board slot labels.

To connect a PDX218, refer to Figure 2-6 and Figure 2-8 and:

1. Connect a SCSI cable from the PDX218 SCSI Bus 2 connector to the Profile system rear panel connector in the slot labeled DISK RECORDER Master.
2. Connect a SCSI cable between SCSI Bus 1 and SCSI Bus 2 on the PDX218.
3. Connect a Terminator to the unused SCSI Bus 1 connector on the PDX218.

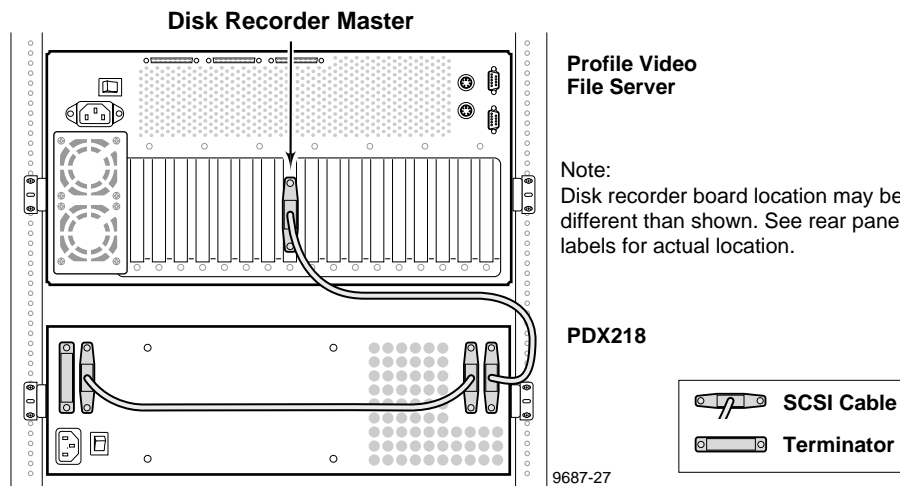

Figure 2-8. Connecting the PDX218 to a Profile System with a Master Disk Recorder Board

The connection shown in Figure 2-8 provides eight 18GB disk drives to the Profile system SCSI A bus.

Two PDX218s Connected to a Profile System with Two Disk Recorder Boards

Figure 2-9 shows a PDX218 connected to a Profile system with Master and Slave Disk Recorder boards installed. The location of the Disk Recorder boards may be different than shown in Figure 2-9. To locate the Disk Recorder boards in your system, see the rear panel board slot labels.

To connect two PDX218s, refer to Figure 2-6 and Figure 2-9 and:

1. Connect a SCSI cable from the first PDX218 SCSI Bus 2 connector to the Profile system rear panel connector in the slot labeled DISK RECORDER Master.
2. Connect a SCSI cable between the SCSI Bus 1 and SCSI Bus 2 connectors on the first PDX218.
3. Connect a Terminator to the unused SCSI Bus 1 connector on the first PDX218.
4. Connect a SCSI cable from the second PDX218 SCSI Bus 1 connector to the Profile system rear panel connector in the slot labeled DISK RECORDER Slave.
5. Connect a SCSI cable between the SCSI Bus 1 and SCSI Bus 2 connectors on the second PDX218.
6. Connect a Terminator to the unused SCSI Bus 2 connector on the second PDX218.

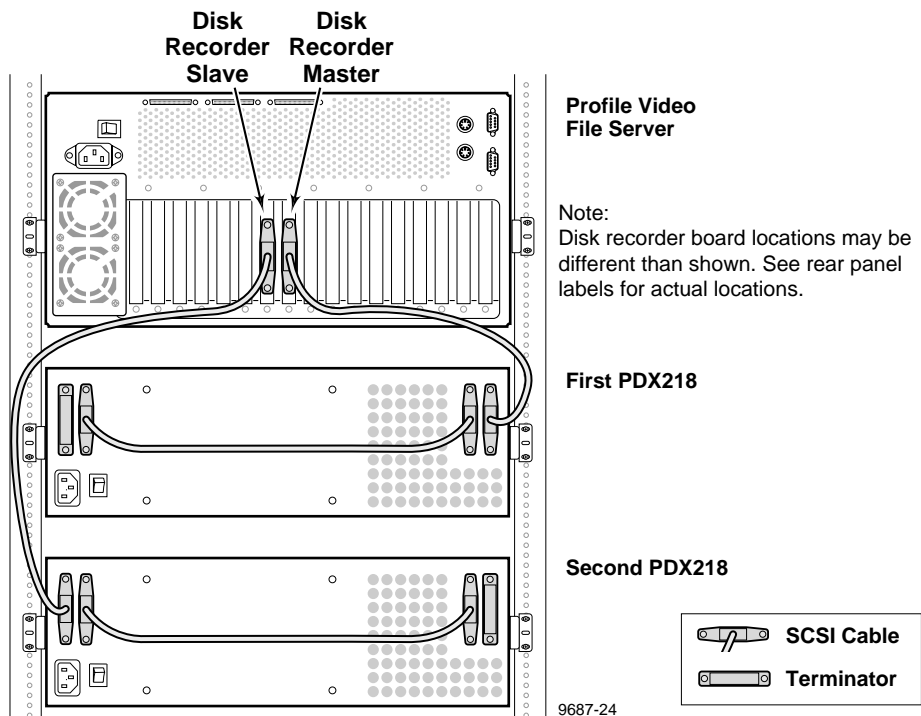

Figure 2-9. Connecting Two PDX218s to a Profile System with Master and Slave Disk Recorder Boards

The connection shown in Figure 2-9 provides eight 18GB disk drives to the SCSI A bus and eight 18GB disk drives to the SCSI C bus on the Profile system (or SCSI A and SCSI B bus on the PDR100).



Power Connections

Power Source

The PDX218 operates from a single-phase power source having one of its current-carrying conductors at or near earth ground (the neutral conductor). A fuse on the line conductor provides over-current protection. Grass Valley Group does not recommend connection to systems whose power source has both current carrying conductors live with respect to ground, such as phase-to-phase in multi-phase systems.

Source Power Frequency and Voltage Ranges

The PDX218 operates at line frequencies of 50 or 60 Hz at nominal voltages from 100 to 240 VAC. Table 2-1 lists the power cord shipped with the PDX218. Figure 2-10 shows the location of the power cord connector and the power switch.

Table 2-1. Power Cords for the PDX218 Disk Expansion Chassis

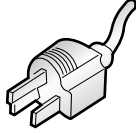
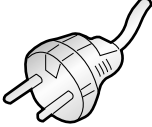
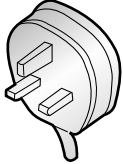
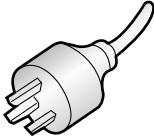
Power Plug	Description
	Standard 120 V, 3-prong power plug on a 2.5 meter long power cord. For use with common ground systems in North America.
	Option A1 Universal European 230V/10A power plug on a 2.5 meter long power cord.
	Option A2 United Kingdom 230V/10A power plug on a 2.5 meter long power cord.
	Option A3 Australian 230V/10A power plug on a 2.5 meter long power cord.

Insure that the power switch is set to 0 (Off). Attach the power cord from the PDX218 to the appropriate power source.

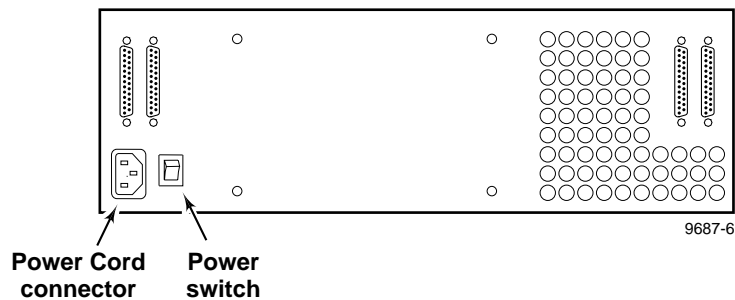

Figure 2-10. PDX218 Power Cord Connector and Switch



Creating a File System on the PDX218

Now that the PDX218 is connected to the Profile system, you must use the Profile Disk Utility to configure the disk drives to store media by creating a file system (also called making a *data set* in the Profile Disk Utility). Refer to the *Profile Family User Manual*, “Using the Profile Disk Utility”, for detailed information about creating a file system on the PDX218 disk drives. In addition, consider the following when creating file systems with the Profile Disk Utility:

- When one PDX218 chassis is connected to a Profile system, the disk drives can be grouped in the following ways:
 - You can create a you a single file system including all external disk drives and internal disk drives (if installed).
 - You can create a single external file system which includes all eight external disk drives and a single internal file system which includes all internal drives (if installed).
- When two PDX218 chassis are connected to a Profile system, the disk drives can be grouped the following ways:
 - You can create a single file system including all external disk drives and all internal disk drives (if installed).
 - You can create a single external file system which includes all sixteen external disk drives. If internal disk drives are installed, you can create a single internal file system.
 - You can create two external file systems, eight disk drives each. Each eight disk file system includes four disks from both PDX218 chassis. If internal disk drives are installed, you can also create a single internal file system.
- If you are connecting the PDX218 to a Profile system with internal disk drives smaller than 18GB, you may want to create two file systems. When creating a file system, the Profile system limits the usable disk space of the larger drives to the size of the smallest drives in the file system. For example, if you are connecting the PDX218 to a PDR100 with 4 GB disks, configure the PDX218 as a separate file system. Making one file system including the internal 4GB drives and the external 18GB drives, limits the PDX218 storage capacity because the Profile system recognizes the drives in the PDX218 chassis as only 4GB drives.
- Some third party control software does not recognize internal and external file systems. In this case, you must create one file system which includes all internal and external disk drives.
- Operating the PDX218 with the Profile Video File Server requires Profile system software 2.2.X greater than 2.2.4, 2.4.X greater than 2.4.4, or 2.5.X and greater.

WARNING

THE FOLLOWING SERVICING INSTRUCTIONS ARE FOR USE BY QUALIFIED PERSONNEL ONLY. TO AVOID PERSONAL INJURY, DO NOT PERFORM ANY SERVICING OTHER THAN THAT CONTAINED IN OPERATING INSTRUCTIONS UNLESS YOU ARE QUALIFIED TO DO SO. REFER TO OPERATOR'S SAFETY SUMMARY AND SERVICE SAFETY SUMMARY PRIOR TO PERFORMING ANY SERVICE.



Service Safety Summary

Review the following safety precautions to avoid injury and prevent damage to this product or any products connected to it.

Only qualified personnel should perform service procedures.

While using this product, you may need to access other parts of the system. Read the *General Safety summary* in other system manuals for warnings and cautions related to operating the system.

Safety Terms and Symbols

Terms in This Manual

These terms may appear in this manual:



WARNING: Warning statements identify conditions or practices that can result in personal injury or loss of life.



CAUTION: Caution statements identify conditions or practices that can result in damage to the equipment or other property.

Terms on the Product

These terms may appear on the product:



DANGER indicates a personal injury hazard immediately accessible as one reads the marking.



WARNING indicates a personal injury hazard not immediately accessible as you read the marking.



CAUTION indicates a hazard to property including the product.

Symbols on the Product

The following symbols may appear on the product:



DANGER high voltage



Protective ground (earth) terminal



ATTENTION – refer to manual



Chapter **3**

Service

This chapter consists of:

- Maintenance information.
- Troubleshooting procedures.
- Removal and replacement procedures for Field Replaceable Units (FRUs).
- Replaceable Parts List
- SCSI connector pin-outs



Maintenance

There is no specifically required periodic maintenance for the PDX218. Cleaning the exterior is on an “as needed” basis. Checking and cleaning or replacing the air filter will depend on the operating environment. Procedures for doing these tasks are discussed below.

 **WARNING:** *To avoid damage to the unit, if a liquid of any kind is spilled onto the PDX218, immediately turn power Off and insure that both the inside and the outside are completely dry before re-applying power.*

Cleaning

Clean the PDX218 often enough to prevent dust or dirt from accumulating. Dirt acts as a thermal insulating blanket that prevents effective heat dissipation, and can provide high-resistance electrical leakage paths between conductors or components in a humid environment.

Exterior

Clean the dust from the outside by wiping with a soft cloth or small brush. A brush is especially useful to remove dust from around the connectors. Hardened dirt may be removed with a cloth dampened in water or a 50% isopropyl alcohol solution. Do not use an abrasive cleaner.

Interior

Clean the interior by loosening accumulated dust with a dry, soft brush. Once the dirt is loosened, remove it with low-pressure air (high-velocity air can damage some parts). Remove hardened dirt or grease with a cotton-tipped applicator dampened with a solution of mild detergent and water. Do not use an abrasive cleaner. If the circuit board assembly must be removed for cleaning, follow the removal/replacement instructions.

After cleaning, allow the interior to thoroughly dry before applying power to the unit.

 **CAUTION:** *Do not allow water to get inside any enclosed assembly or component. Do not clean any plastic materials with organic cleaning solvents, such as benzene, toluene, xylene, acetone, or similar compounds, because they may damage the plastic.*

Cleaning and Changing the Air Filter

In a humid environment, the air filter behind the front bezel of the PDX218 will usually require more frequent attention than in a dryer environment. Figure 3-1 shows the location of the filter which requires removal of the front bezel. To remove the air filter for cleaning or replacement, refer to Figure 3-1, and proceed as follows:

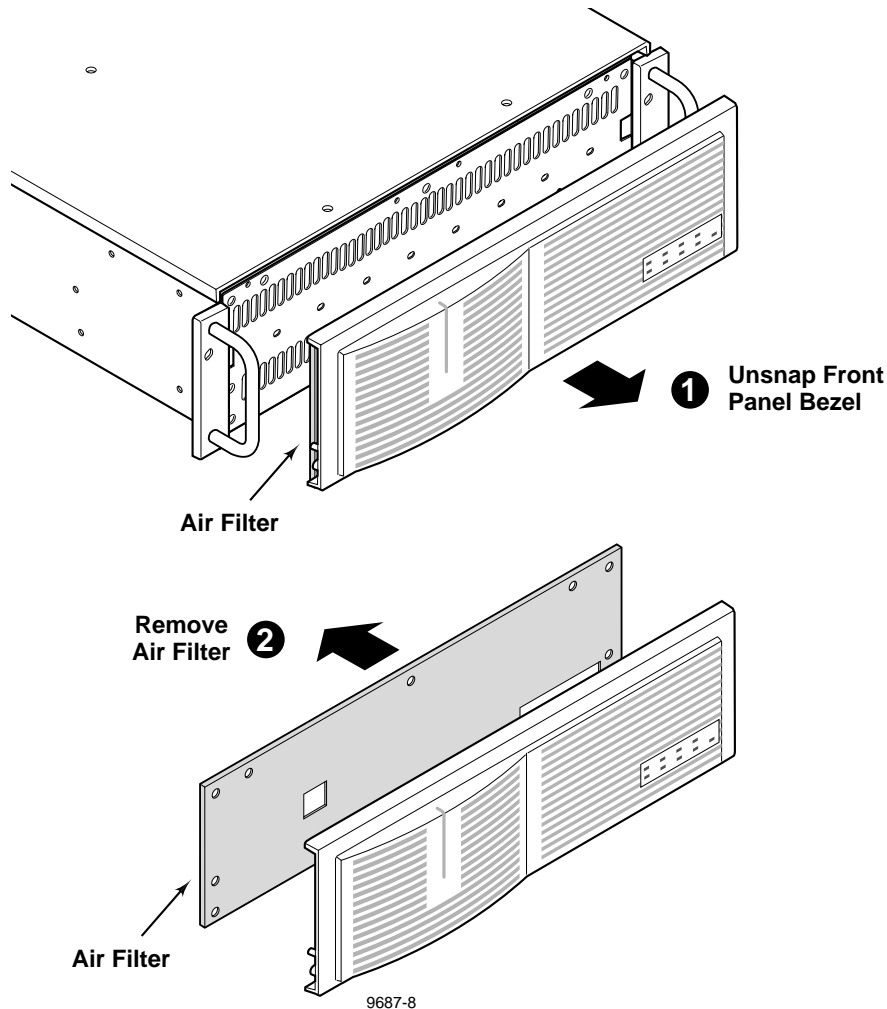

Figure 3-1. PDX218 Air Filter Removal

1. Unsnap the front panel bezel by firmly pulling away from the front panel.
2. Detach the air filter from the studs behind the bezel.
3. If cleaning, use a low pressure air supply to blow contaminants out of the filter.
4. Attach the filter to the bezel as shown in Figure 3-1.
5. Position the front panel bezel mounting posts over the holes in the front panel and snap the bezel back in place.



Troubleshooting

If you suspect that the PDX218 is the cause of a Profile-related problem:

- Check all SCSI cable connections.
- Check the power cord connection.
- Insure the On/Off switch is On.
- Insure that the power switch and line filter are good.
- Check the indicators on the front panel (Figure 3-2) which provide information to assist in fault isolation.

If it is necessary to replace a component, see **Removal and Replacement Procedures** later in this chapter.

Refer to Figure 3-2 in the following discussions.

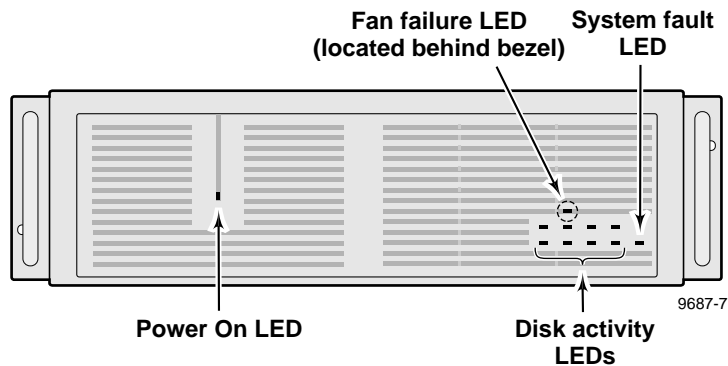

Figure 3-2. PDX218 Front Panel Indicators

Power On Indicator

The chassis power green LED indicator should be On.

If Off

- Power Supply bad, replace Power Supply.
- Fuse F1 or F3 on SCSI Distribution board blown, replace SCSI Distribution board.
- LED cable assembly bad, replace cable assembly.

Disk Activity Indicators

These eight green LED indicators show Disk Activity.

If one or more LED(s) is frozen On or Off.

- Profile system crash, see *Profile Family User Manual* or *Profile Service Manual*.
- One or more bad disk drives. One bad disk drive will, after a few seconds, cause all the Disk Activity LEDs to freeze On or Off. Turn PDX218 power off, then, while observing these LEDs, turn power back on. The bad disk drive will not show activity, replace that drive.
- SCSI Distribution board bad, replace.
- An external or internal cable is loose or bad. Check all cables, reconnect or replace as necessary.

All Disk Activity LEDs go off, but PDX218 remains operative.

- Fuse F3 on SCSI Distribution board blown, replace SCSI Distribution board.

Disk Activity LEDs do not flash.

- LED Board bad, replace LED Board.
- Disk Drive LEDs cable bad, replace.

System Fault Indicator

The System Fault red LED indicator may be On under the two conditions listed below. Remove the front bezel to determine which condition is present.

1. System Fault LED On but Fan Fault indicator LED Off, one (or more) of the terminal power fuses on the SCSI Distribution board has blown, replace SCSI Distribution board.
2. System Fault LED On and the Fan Fault indicator LED On, one (or more) of the fans is bad. Turn PDX218 power Off, remove the top cover (see ***Removal and Replacement Procedures***), briefly turn power back On. Replace whichever fan is not turning.

Fan Fault Indicator

The Fan fault red LED indicator is behind the front panel bezel. See above description on System Indicator.



Removal and Replacement Procedures

This section identifies the replaceable parts of the PDX218 and the procedures to remove and replace them.

NOTE: *Do not discard any hardware unless specifically instructed to do so.*

 **WARNING:** *To avoid electric shock, insure that the power cord is disconnected prior to performing any removal and replacement procedure.*

Replaceable Parts

Table 3-1 lists the PDX218 replaceable parts. Figure 3-3, keyed to Table 3-1, shows the parts.

Table 3-1. PDX218 Replaceable Part List

Key	Part Number	Description
1	119-5195-XX	Power Supply
2	119-4827-XX	Fan, DC
3	671-4120-XX	SCSI Distribution Board, Single Ended
4	119-6086-XX	Video Disk Drive, 18GB, Single Ended
5	407-4478-XX	Disk Drive Caddie
6	174-3748-XX	Cable, Power Supply to SCSI Distribution Board
7	174-3612-XX	Cable, Line In to Power Supply
8	174-3586-XX	Cable, Line In/Switch to Power Supply
9	174-3668-XX	Cable, SCSI Internal/External
10	174-3751-XX	Cable, Disk Drive to LED
11	671-3948-XX	LED Board Assy, PDX218
12	174-3616-XX	Cable Assy, LED
13	378-0432-XX	Air Filter
14	333-4222-XX	Front Bezel
15	200-4295-XX	Front Plastic Ear
16	367-0450-XX	Handle, Front Chassis
17	174-3517-XX 174-4181-XX 174-4182-XX	Cable, External SCSI, Standard Profile system to PDX218, 73 inch Cable, External SCSI, Profile system to PDX218, 3 foot Cable, External SCSI, Profile system to PDX218, 10 foot
18	011-0166-XX	Terminator, SCSI

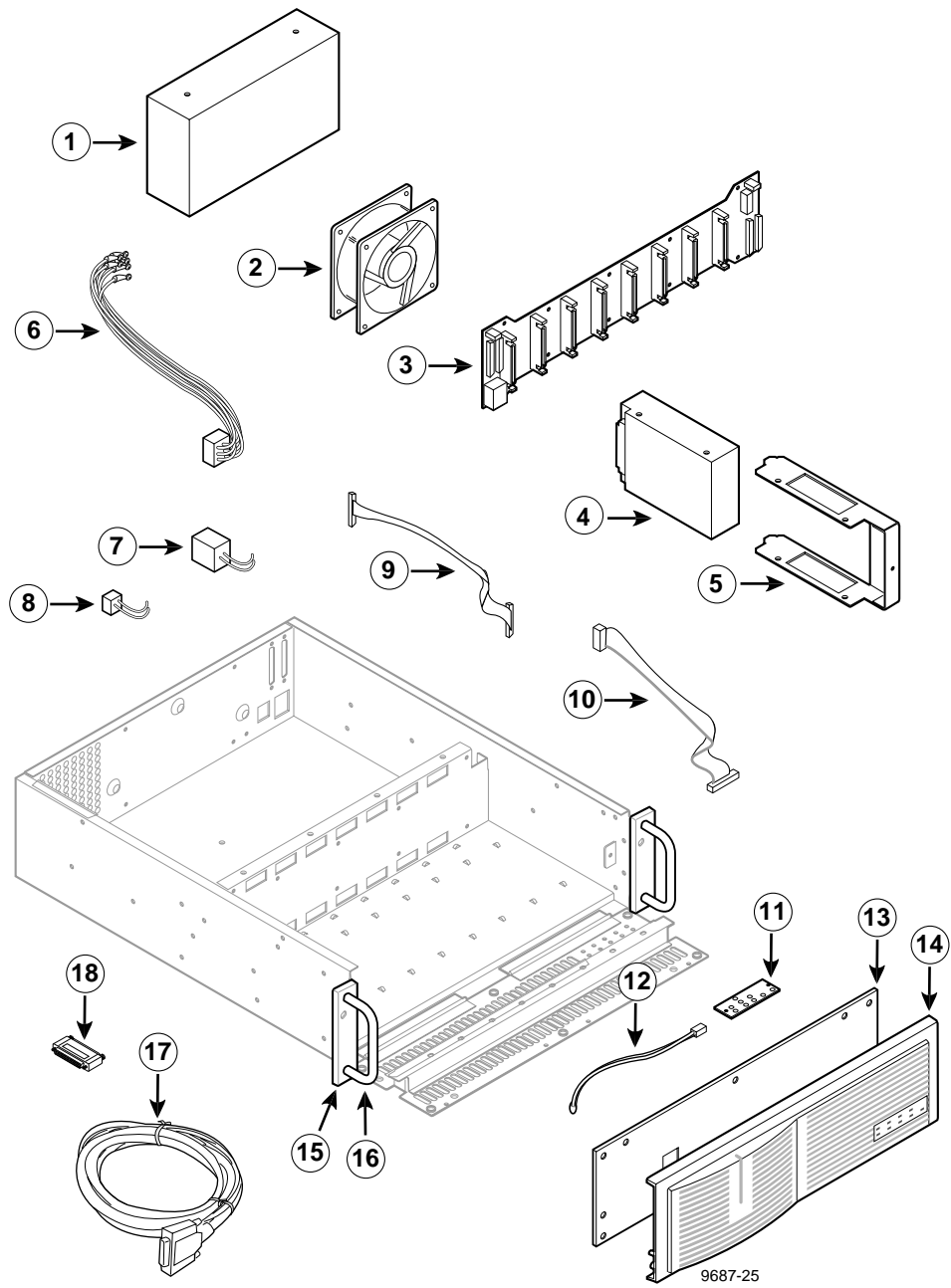

Figure 3-3. Replaceable Parts



Removing and Replacing the Front Panel Bezel and Air Filter

For front panel bezel and air filter removal/replacement, see *Cleaning and Changing the Air Filter* previously discussed in this chapter.

Removing and Replacing a Disk Drive

A disk drive caddy holds each disk drive in place (items 4 and 5 in Table 3-1). If in troubleshooting the PDX218, a disk drive is determined to be bad, the hinged front panel must be loosened and lowered, and the appropriate caddy must be removed before the disk drive can be removed and replaced. It is not necessary to remove the PDX218 from the rack to perform this procedure. See Figure 3-4 to lower the front panel and Figure 3-5 to remove the caddy and disk drive.

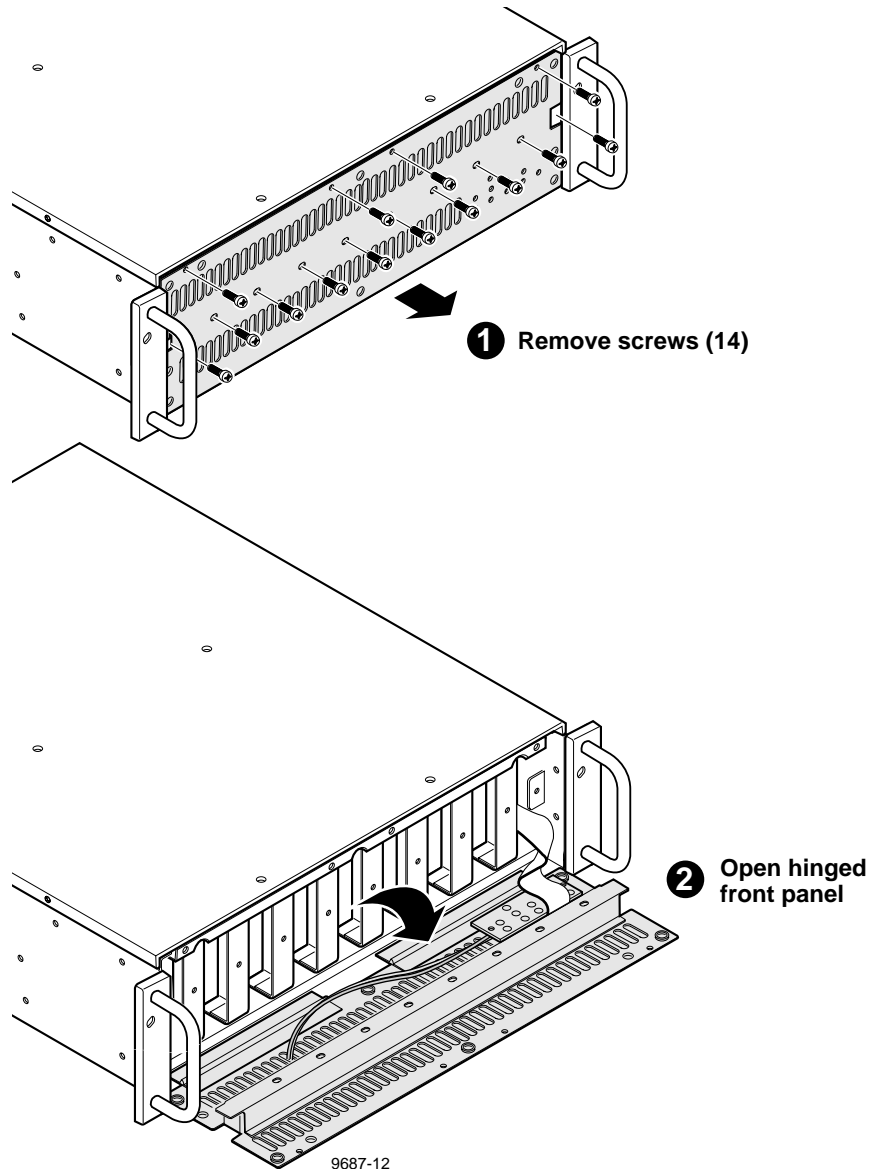

Figure 3-4. Lowering the Front Panel

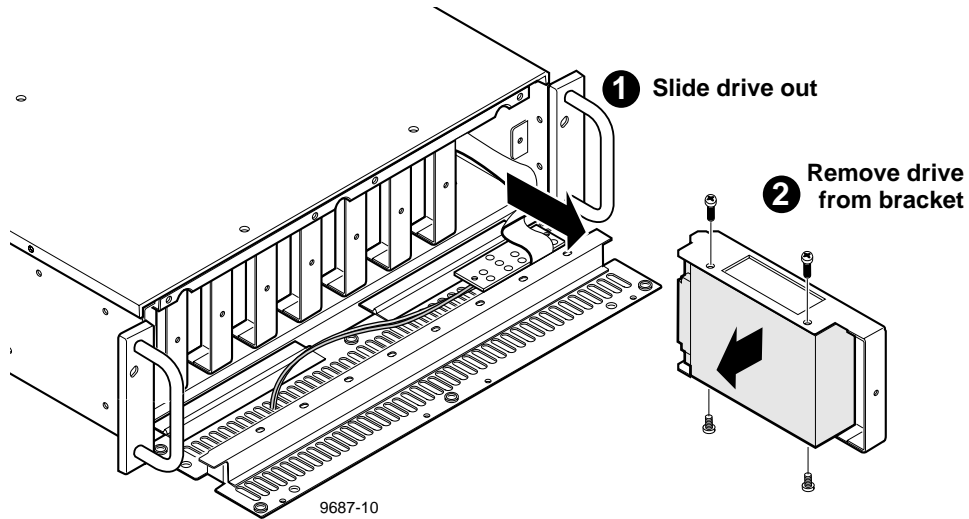

Figure 3-5. PDX218 Disk Drive Caddy and Disk Drive Removal

To remove a caddy and disk drive:

1. Unsnap the front panel bezel by firmly pulling away from the front panel (Figure 3-1).
2. Remove the retaining screws from the front panel. (Figure 3-4) (These are also caddy retaining screws.)
3. Lower the front panel.
4. Grasp the appropriate caddy, pull straight out of the chassis, and place on a level, static-proof surface (Figure 3-5).
5. Remove the drive mounting screws and remove the drive from the caddy.

To install a disk drive and reinstall a caddy:

1. Mount the new drive in the caddy using the screws previously removed from the caddy (Figure 3-5).
2. Slide the caddy into the chassis.
3. Raise the front panel and secure it with the screws previously removed (Figure 3-4).
4. Position the front panel bezel mounting posts over the holes in the front panel and press firmly until the bezel snaps back in place (Figure 3-1).



Removing and Replacing the LED Board

The LED Board (item 11 in Table 3-1) is on the front panel. It is not necessary to remove the PDX218 from the rack to perform this procedure. Figure 3-6 shows removal of the LED board.

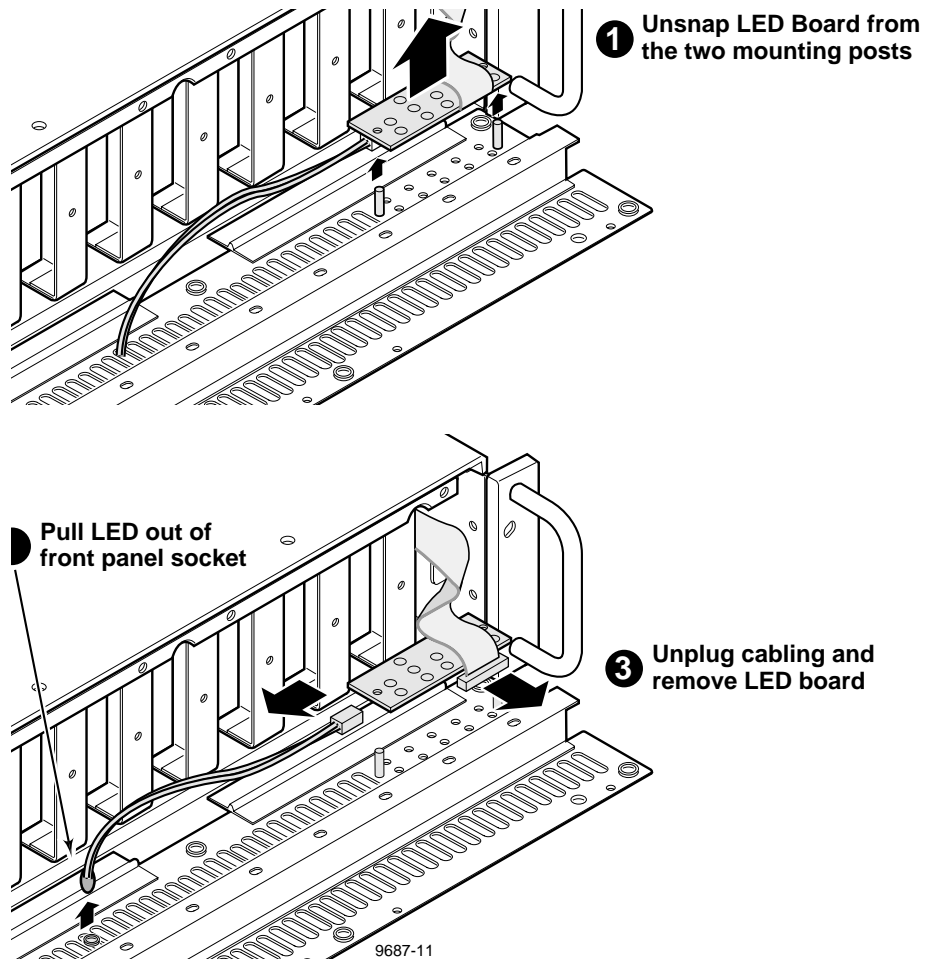

Figure 3-6. PDX218 LED Board and Cable Removal

To remove LED board:

1. Unsnap the front panel bezel by firmly pulling away from the front panel (Figure 3-1).
2. Remove the retaining screws from the front panel. (Figure 3-4) (These are also caddie retaining screws.)
3. Lower the front panel.
4. Unsnap the LED board from the mounting posts (Figure 3-6) by pulling the board straight up from the front panel.
5. Disconnect the cables from the LED board.

To install the LED board:

1. Connect the previously removed cables to the LED board.
2. Position the LED board over the mounting posts in the front panel and firmly press down until the LED board snaps into place (Figure 3-6).
3. Raise the front panel and secure with the screws previously removed (Figure 3-4).
4. Position the front panel bezel mounting posts over the holes in the front panel and press firmly until the bezel snaps back in place (Figure 3-1).

Removing and Replacing the LED Cable Assembly

This cable assembly (item 12 in Table 3-1) connects from the LED board to the front panel power LED. It is not necessary to remove the PDX218 from the rack to perform this procedure. Figure 3-6 shows removal of the LED cable assembly. To remove LED cable assembly:

1. Unsnap the front panel bezel by firmly pulling away from the front panel (Figure 3-1).
2. Remove the retaining screws from the front panel. (Figure 3-4) (These are also caddie retaining screws.)
3. Lower the front panel.
4. Unsnap the LED board from the mounting posts (Figure 3-6) by pulling the board straight up from the front panel.
5. Disconnect the LED cable assembly from the LED board (Figure 3-6).
6. Pull the LED end of the cable out of the front panel socket.

To install the LED board:

1. Connect the new LED cable assembly to the LED board (Figure 3-6).
2. Position the LED board over the mounting posts in the front panel and firmly press down until the LED board snaps into place (Figure 3-6).
3. Insert the LED end of the cable into the front panel socket.
4. Raise the front panel and secure with the screws previously removed (Figure 3-4).
5. Position the front panel bezel mounting posts over the holes in the front panel and press firmly until the bezel snaps back in place (Figure 3-1).



Removing and Replacing the Disk Drive LEDs Cable

This cable (item 10 in Table 3-1), for the disk drive activity LEDs, connects from the LED board on the front panel to the SCSI Distribution board. It is not necessary to remove the PDX218 from the rack to perform this procedure. Figure 3-7 shows the LED board and cables.

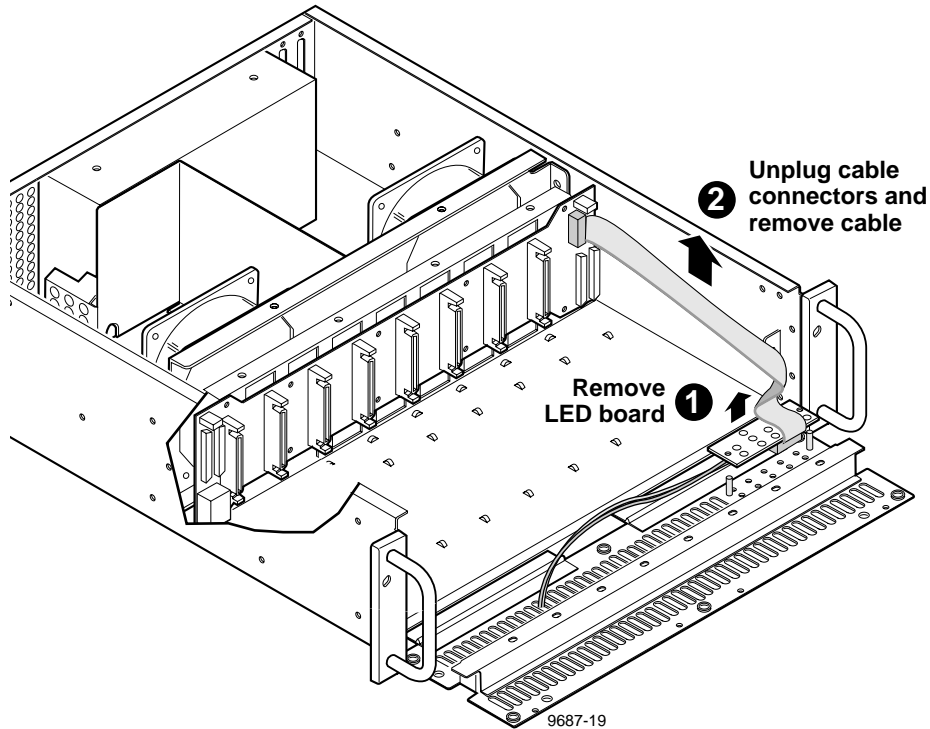

Figure 3-7. Disk Drive LEDs Cable Removal

To remove the Disk Drive LEDs cable:

1. Unsnap the front panel bezel by firmly pulling away from the front panel (Figure 3-1).
2. Remove the retaining screws from the front panel (Figure 3-4). (These are also caddie retaining screws.)
3. Lower the front panel.
4. Unsnap the LED board from the mounting posts (Figure 3-6) by pulling the board straight up from the front panel.
5. Disconnect the Disk Drive LEDs cable from the LED board (Figure 3-7).
6. Remove as many caddies as necessary to reach the Disk Drive LEDs cable where it connects to the SCSI Distribution board (Figure 3-7). (See *Removing a Disk Drive*.)
7. Disconnect the Disk Drive LEDs cable from the SCSI Distribution board.

To install a new Disk Drive LEDs cable:

1. Connect the new Disk Drive LEDs cable from the LED board to the SCSI Distribution board (Figure 3-7).
2. Replace the caddies previously removed.
3. Position the LED board over the mounting posts on the front panel and firmly press down until the board snaps into place (Figure 3-6).
4. Raise the front panel and secure with the screws previously removed (Figure 3-4).
5. Position the front panel bezel mounting posts over the holes in the front panel and press firmly until the bezel snaps back in place (Figure 3-1).

Removing the Top Cover

Figure 3-8 shows removal of the top cover, which must be removed to access the interior for removal of other parts. To remove the top cover, refer to Figure 3-8 and:

1. Remove the PDX218 from the equipment rack.
2. Remove the cover mounting screws.
3. Lift the cover up and off the chassis.

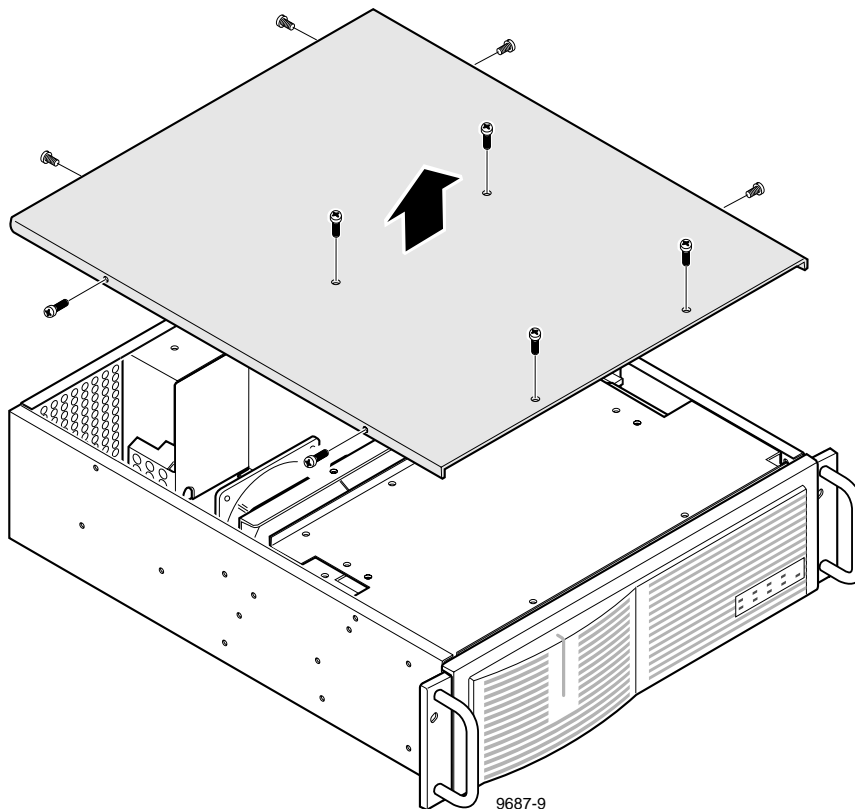

Figure 3-8. PDX218 Top Cover Removal



Removing the Disk Tray Cover

Figure 3-9 shows removal of the disk tray cover, which must be removed to gain access for removal of other parts.

To remove the disk tray cover:

1. Remove the PDX218 from the equipment rack.
2. Remove the top cover (Figure 3-8).
3. Unsnap the front panel bezel (Figure 3-1).
4. Remove the front panel retaining screws and lower the front panel (Figure 3-4).
5. Remove all disk drive caddies (Figure 3-5).
6. Remove the screws and L-brackets, one on each side (Figure 3-9).
7. Remove the Disk Tray cover mounting screws.
8. Slide the Disk Tray cover out through the front of the chassis.

To install the disk tray cover:

1. Slide the Disk Tray cover in through the front of the chassis and secure with the screws previously removed (Figure 3-9).
2. Install the L-brackets with the screws previously removed.
3. Install all disk drive caddies (Figure 3-5) previously removed.
4. Raise the front panel and secure with the screws previously removed (Figure 3-4).
5. Position the front panel bezel mounting posts over the holes in the front panel and press firmly until the bezel snaps back in place (Figure 3-1).
6. Replace the top cover (Figure 3-8).
7. Reinstall the PDX218 into the equipment rack.

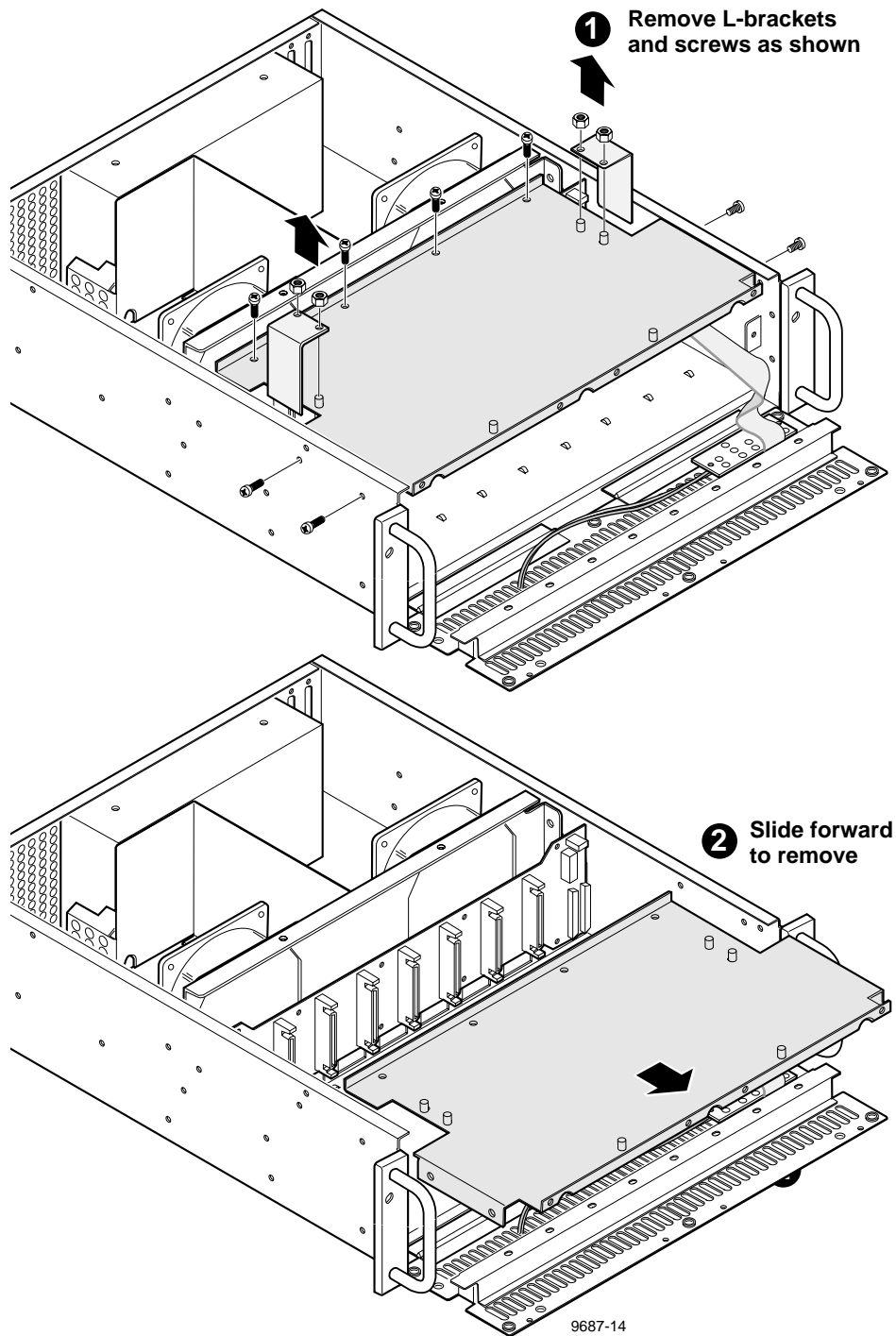

Figure 3-9. PDX218 Disk Tray Cover Removal



Removing and Replacing a SCSI Cable

Internal SCSI cables (item 9 in Table 3-1) connect from two connectors on each side of the SCSI Distribution board to the two rear panel SCSI connectors on the same side of the chassis. Figure 3-10 shows removal of an internal SCSI cable.

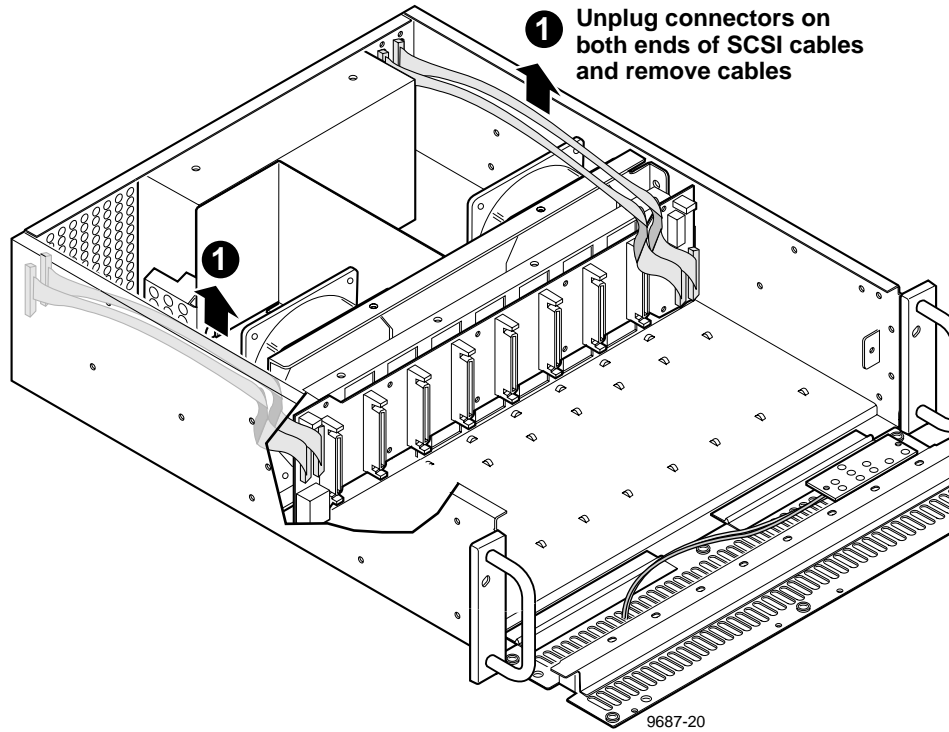

Figure 3-10. Removal of a SCSI Cable

To remove an internal SCSI cable:

1. Remove the PDX218 from the equipment rack.
2. Remove the top cover (Figure 3-8).
3. Remove the Disk Tray cover (Figure 3-9).
4. If necessary, remove disk caddie(s).
5. Disconnect the bad SCSI cable connector from the SCSI Distribution board (Figure 3-10).
6. Disconnect the connector at the other end of the bad SCSI cable from the rear panel.

To install a SCSI cable:

1. Connect the SCSI cable from the appropriate rear panel connector to the appropriate SCSI connector on the SCSI Distribution board (Figure 3-10).
2. Install any disk caddies previously removed.
3. Install the Disk Tray cover (Figure 3-9).
4. Replace the top cover (Figure 3-8).
5. Reinstall the PDX218 into the equipment rack.



Removing and Replacing the SCSI Distribution Board Power Cable

Figure 3-11 shows removal of the cable that provides power from the Power Supply to the SCSI Distribution board (item 6 in Table 3-1).

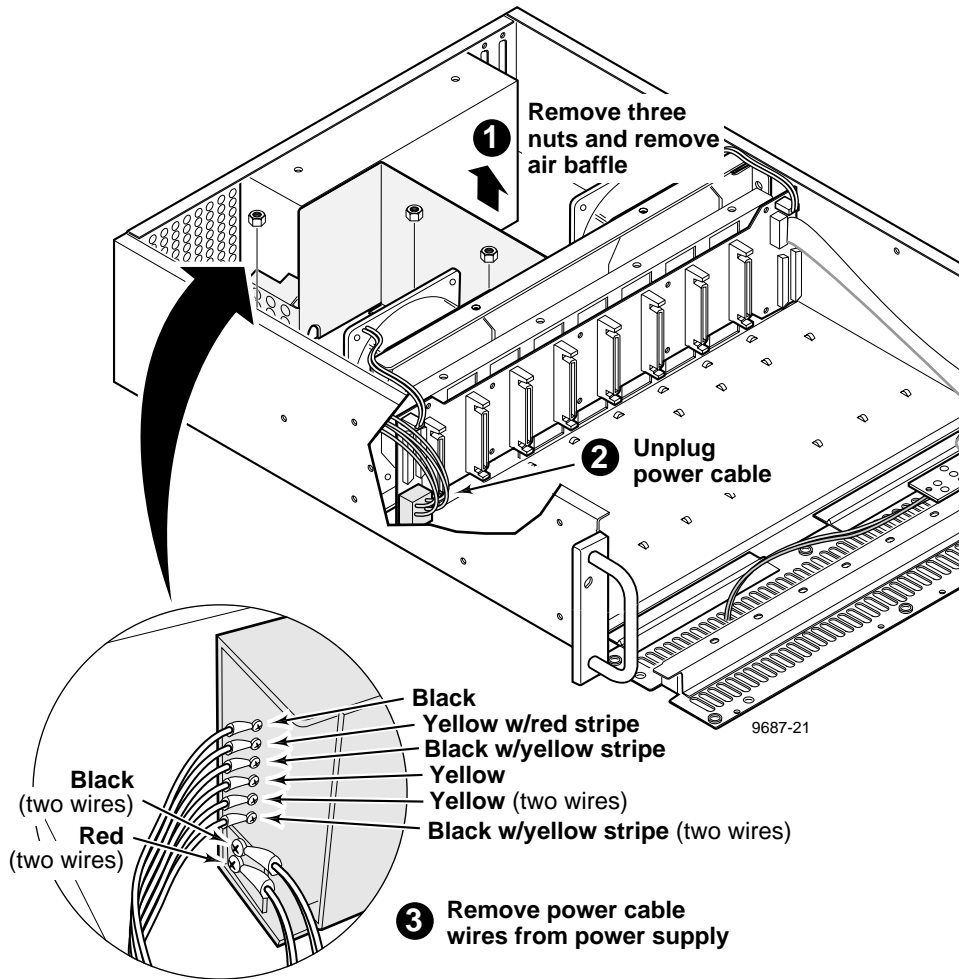

Figure 3-11. Removal of the SCSI Distribution Board Power Cable

To remove the SCSI Distribution board power cable:

1. Remove the PDX218 from the equipment rack.
2. Remove the top cover (Figure 3-8).
3. Remove the Disk Tray cover (Figure 3-9).
4. Remove as many caddies as necessary to access the Power Supply connector on the left side of the SCSI Distribution board (Figure 3-5).
5. Disconnect the Power Supply connector from the SCSI Distribution board (Figure 3-11).
6. Remove the air baffle.
7. Disconnect the SCSI Distribution board power cable wires from the Power Supply.

To install the SCSI Distribution board power cable:

1. Connect the cable wires to the left side (as facing the chassis) of the Power Supply (see the insert in Figure 3-11).
2. Connect the Power Supply cable connector to the SCSI Distribution board.
3. Reinstall the air baffle.
4. Install the Disk Tray cover (Figure 3-9).
5. Replace the top cover (Figure 3-8).
6. Reinstall the PDX218 into the equipment rack.



Removing and Replacing the Switch Cable

Figure 3-12 shows removal of the cable assembly that connects the Power Supply to the rear panel switch (item 8 in Table 3-1). This assembly includes the switch.

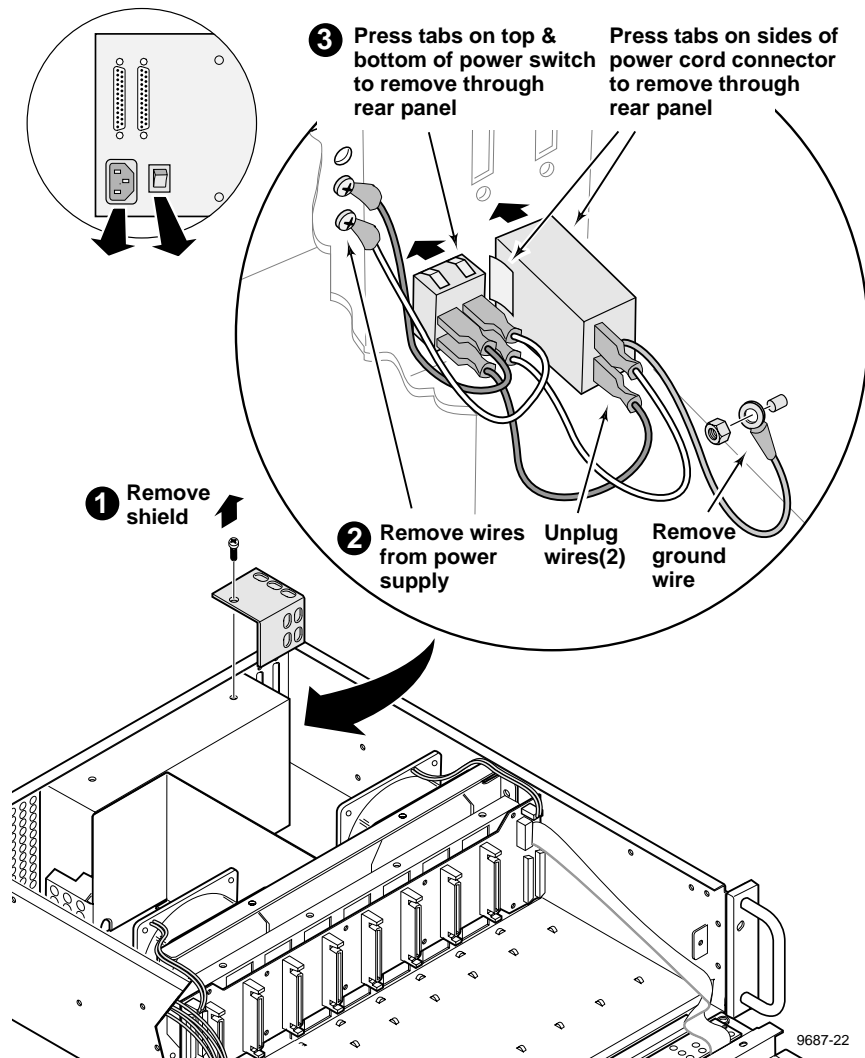

Figure 3-12. Removal of the Switch and Line In Cables

To remove the Switch cable:

1. Remove the PDX218 from the equipment rack.
2. Remove the top cover (Figure 3-9).
3. Remove the shield (Figure 3-12).
4. Disconnect the black and white cable wires from the right side of the Power Supply (Figure 3-12).
5. Disconnect the switch cable wires from the power connector.
6. Compress the retaining clips on the top and bottom of the switch and remove the switch out of the chassis through the rear panel.

To install the Switch cable:

1. Install the switch into the chassis through the rear panel with **0** (Off) at the bottom.
2. Connect the switch cable wires to the right side of the Power Supply as shown in the insert in Figure 3-12.
3. Connect the switch cables wires to the power connector as shown in the insert in Figure 3-12.
4. Replace the shield.
5. Replace the top cover (Figure 3-8) and reinstall the PDX218 into the rack.

Removing and Replacing the Line In Cable

Figure 3-12 shows the cable assembly that connects the switch to the power cord connector (item 7 in Table 3-1). This assembly includes the source power connector and line filter. To remove the power connector cable assembly:

1. Remove the PDX218 from the equipment rack.
2. Remove the top cover (Figure 3-8).
3. Remove the shield (Figure 3-12).
4. Disconnect the power connector wires from the switch assembly (Figure 3-12).
5. Remove the chassis ground wire retaining nut.
6. Compress the retaining clips on each side of the power connector assembly and remove the connector out of the chassis through the rear panel.

To install the Line In cable assembly:

1. Install the Line In assembly into the chassis through the rear panel with the ground contact of the connector to the near side of the chassis.
2. Connect the power connector cable wires to the switch assembly as shown in the insert in Figure 3-12.
3. Attach the chassis ground wire as shown in Figure 3-12.
4. Replace the shield (Figure 3-12).
5. Replace the top cover (Figure 3-8) and reinstall the PDX218 into the rack.



Removing and Replacing the Power Supply

Figure 3-13 shows removal of the Power Supply (item 1 in Table 3-1).

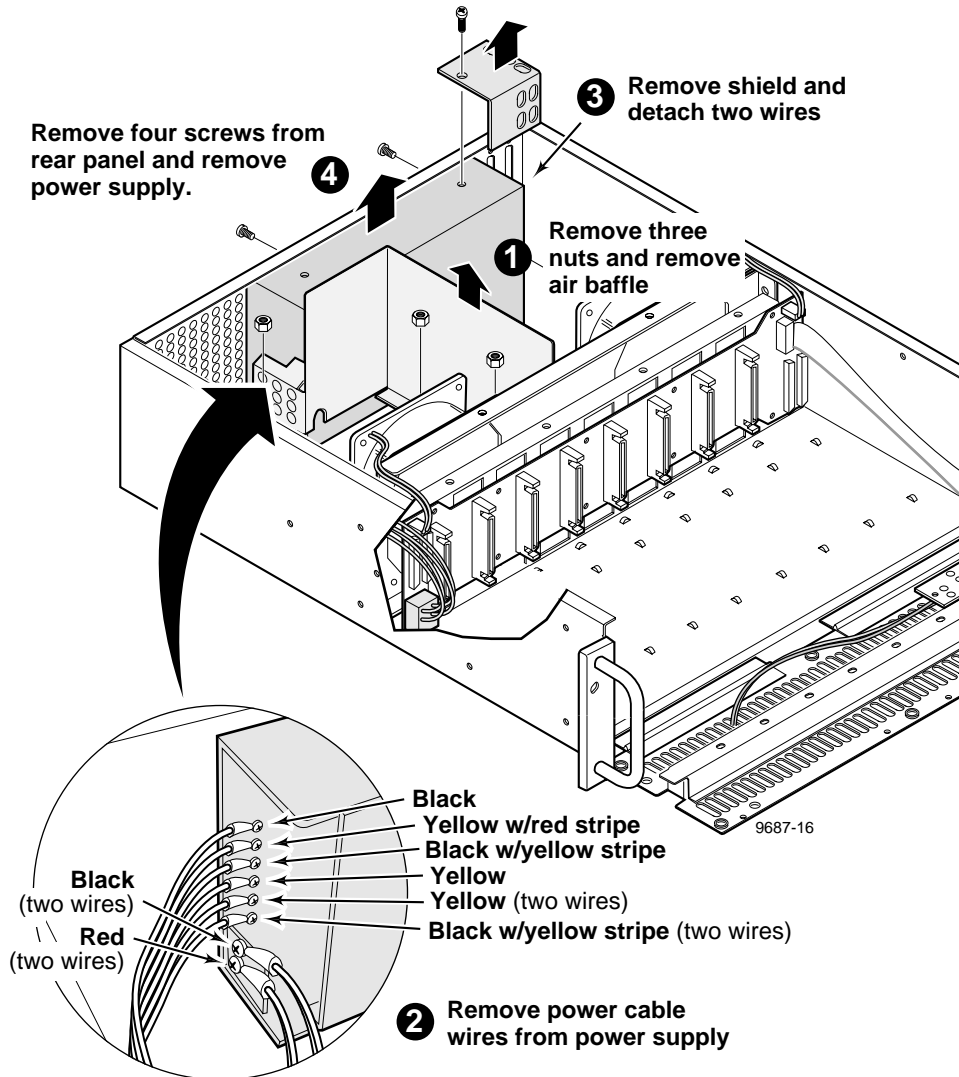

Figure 3-13. PDX218 Power Supply Removal

To remove the power supply:

1. Remove the PDX218 from the equipment rack.
2. Remove the top cover (Figure 3-8).
3. Remove the Disk Tray cover (Figure 3-9).
4. Remove the shield from the right side of the Power Supply (Figure 3-13)
5. Remove the mounting nuts from the air baffle and lift the baffle up and out of the chassis (Figure 3-13).
6. Remove the Power Supply mounting screws from the rear panel and lift the Power Supply up and out of the chassis just enough to access the cable wire connections on each side of the Power Supply.
7. Disconnect the SCSI Distribution board cable wires from the left side of the Power Supply (Figure 3-13).
8. Disconnect the black and white Switch cable wires from the right side of the Power Supply (Figure 3-13).
9. Lift the Power Supply completely free of the chassis.

To reinstall the power supply:

1. Connect the cable wires from the Switch to the right side of the Power Supply (Figure 3-13).
2. Connect the SCSI Distribution board cable wires to the left side of the Power Supply (Figure 3-13).
3. Position the Power Supply at the rear panel and mount with the screws previously removed (Figure 3-13).
4. Replace the shield.
5. Replace the air baffle using the mounting nuts previously removed.
6. Replace the top cover (Figure 3-8).
7. Reinstall the PDX218 into the equipment rack.



Removing and Replacing a Fan

Figure 3-14 shows removal of a fan (item 2 in Table 3-1).

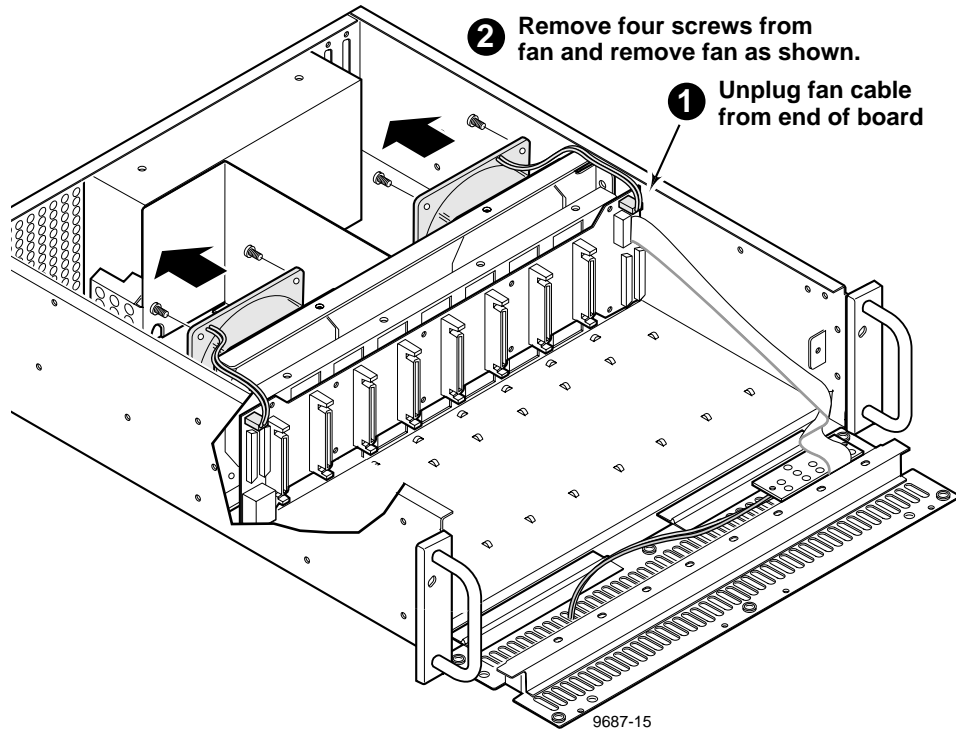

Figure 3-14. PDX218 Fan Removal

To remove a fan:

1. Remove the PDX218 from the rack.
2. Remove the top cover (Figure 3-8).
3. Remove the Disk Tray cover (Figure 3-9).
4. Disconnect the appropriate fan cable from the left or right side of the SCSI Distribution board (Figure 3-14).
5. Remove the appropriate fan mounting screws and lift the fan up and out of the chassis.

To install a fan:

1. Position the fan and mount with the screws previously removed (Figure 3-14)
2. Connect the new fan cable to the left or right side of the SCSI Distribution board.
3. Reinstall the Disk Tray cover (Figure 3-9).
4. Replace the top cover (Figure 3-8).
5. Reinstall the PDX218 into the Equipment rack.



Removing and Replacing the SCSI Distribution Board

Figure 3-15 shows removal of the SCSI Distribution board.

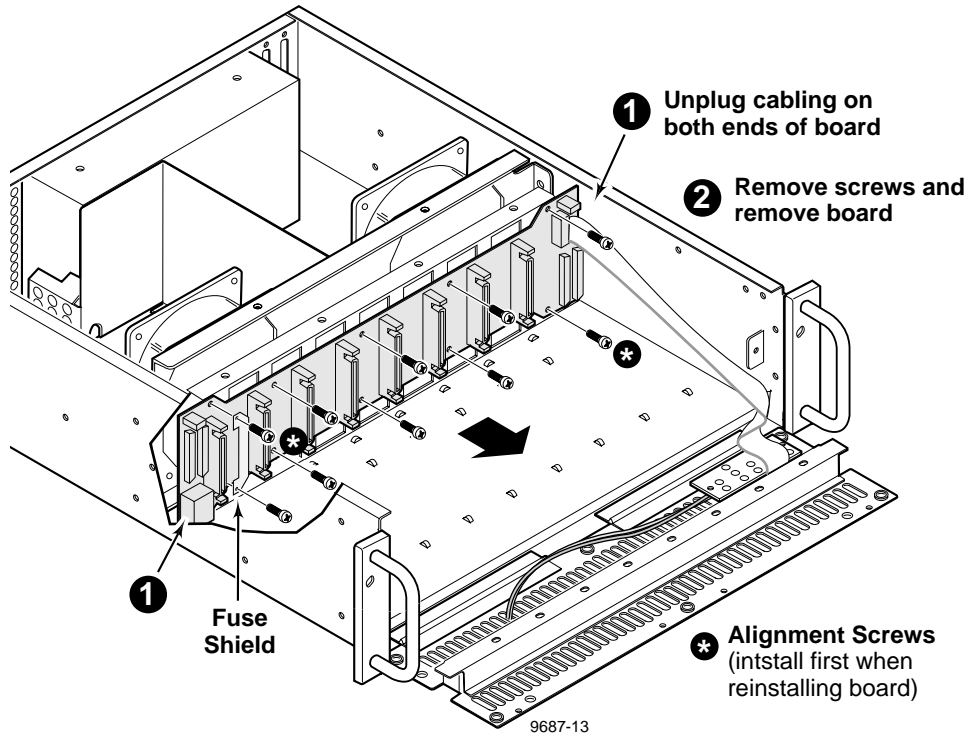

Figure 3-15. PDX218 SCSI Distribution Board Removal

To remove the SCSI Distribution board:

1. Remove the PDX218 from the equipment rack.
2. Remove the top cover (Figure 3-8)
3. Remove the Disk Tray cover (Figure 3-9).
4. Unsnap the front panel bezel (Figure 3-1).
5. Remove the retaining screws from the front panel (Figure 3-4). (These screws also retain the caddies.)
6. Lower the front panel.
7. Remove the disk drive caddies (Figure 3-5).
8. Disconnect all cables (listed below) from the SCSI Distribution board (Figure 3-15).
 - Fan power cable from each side
 - LED board cable (right side)
 - 2 SCSI Bus 1 cables (right side)
 - 2 SCSI Bus 2 cables (left side)
 - SCSI Distribution board power cable (left side)
9. Remove the two SCSI Distribution board mounting screws on the left side. These two screws hold the fuse shield in place. (The fuse shield also captures these screws.)
10. Remove the remaining screws and lift the board up and out of the chassis.

To install the SCSI Distribution board:

1. Align the SCSI Distribution board in the chassis by attaching the screw at the lower right and the screw at the upper left (Figure 3-15).

Note that the upper and lower left screws are held captive on the fuse shield.)
2. Attach the lower left screw and all other mounting screws previously removed.
3. Connect all previously disconnected cables to the SCSI Distribution board (Figure 3-15).
4. Replace the disk drive caddies (Figure 3-5).
5. Replace the Disk Tray cover (Figure 3-9).
6. Replace the top cover (Figure 3-8)
7. Raise the front panel and secure with the retaining screws previously removed (Figure 3-4).
8. Position the front panel bezel mounting posts over the holes in the front panel and press firmly until the bezel snaps back in place (Figure 3-1).
9. Reinstall the PDX218 into the equipment rack.



SCSI-2 Connector Pin-outs

The PDX218 provides four SCSI-2 68-pin interface connectors at the rear panel; two on the right side (as facing the rear panel) for the SCSI A bus and two on the other side for the SCSI C bus. All SCSI-2 connectors have the same pin-outs. Figure 3-16 shows the connector and Table 3-2 lists the signals. Note that in the table, signals preceded by a dash (-) indicate signals that are true, asserted, and active when low.

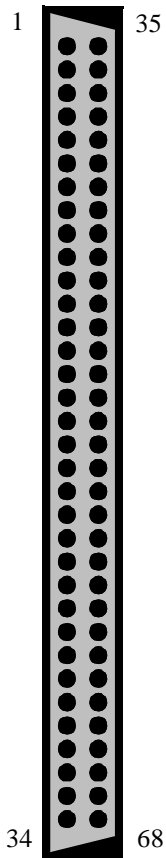

Figure 3-16. SCSI-2 Connector

Table 3-2. SCSI-2 Connector Pin-outs

Pin #	Mnemonic	Signal Description	Pin #	Mnemonic	Signal Description
1	DB12	Data Bus bit 12	35	-DB12	Data Bus bit 12
2	DB13	Data Bus bit 13	36	-DB13	Data Bus bit 13
3	DB14	Data Bus bit 14	37	-DB14	Data Bus bit 14
4	DB15	Data Bus bit 15	38	-DB15	Data Bus bit 15
5	DB P1	Data Bus Parity (8-15)	39	-DB P1	Data Bus Parity (8-15)
6	GND	Signal Ground	40	GND	Signal Ground
7	DB0	Data Bus bit 0	41	-DB0	Data Bus bit 0
8	DB1	Data Bus bit 1	42	-DB1	Data Bus bit 1
9	DB2	Data Bus bit 2	43	-DB2	Data Bus bit 2
10	DB3	Data Bus bit 3	44	-DB3	Data Bus bit 3
11	DB4	Data Bus bit 4	45	-DB4	Data Bus bit 4
12	DB5	Data Bus bit 5	46	-DB5	Data Bus bit 5
13	DB6	Data Bus bit 6	47	-DB6	Data Bus bit 6
14	DB7	Data Bus bit 7	48	-DB7	Data Bus bit 7
15	DB P	Data Bus Parity (0-7)	49	-DB P	Data Bus Parity (0-7)
16	DIFFSENS	Differential (Drive) Sensor	50	GND	Signal Ground
17	TERMPWR	Termination Power	51	TERMPWR	Termination Power
18	TERMPWR	Termination Power	52	TERMPWR	Termination Power
19	Reserved	n.a.	53	Reserved	n.a.
20	ATN	Attention	54	-ATN	Attention
21	GND	Signal Ground	55	GND	Signal Ground
22	BSY	SCSI Bus Busy	56	-BSY	SCSI Bus Busy
23	ACK	Data Xfer Acknowledge	57	-ACK	Data Xfer Acknowledge
24	RST	Reset	58	-RST	Reset
25	MSG	Message	59	-MSG	Message
26	SEL	Select	60	-SEL	Select
27	C/D	(Control)Data	61	-C/D	Control(Data)
28	REQ	Data Xfer Request	62	-REQ	Data Xfer Request
29	I/O	Input/Output	63	-I/O	Input/Output
30	GND	Signal Ground	64	GND	Signal Ground
31	DB8	Data Bus bit 8	65	-DB8	Data Bus bit 8
32	DB9	Data Bus bit 9	66	-DB9	Data Bus bit 9
33	DB10	Data Bus bit 10	67	-DB10	Data Bus bit 10
34	DB11	Data Bus bit 11	68	-DB11	Data Bus bit 11



Index

A

- Air Filter
 - Changing 3-3
 - Cleaning 3-3

C

- Cable
 - Disk Drive LEDs, Removal and Replacement 3-12
 - Line In, Removal and Replacement 3-21
 - Power LED, Removal and Replacement 3-11
 - SCSI, Removal and Replacement 3-16
 - Switch, Removal and Replacement 3-20
- Cable, SCSI Distribution Board Power, Removal and Replacement 3-18
- Canadian Certified Power Cords xi
- Canadian EMC Notice of Compliance xi
- Certification xi
- Certifications and Compliances xi
- Changing the Air Filter 3-3
- Cleaning 3-2
 - Exterior 3-2
 - Interior 3-2
- Cleaning and Changing the Air Filter 3-3
- Connecting to a Profile system with one disk recorder board 2-8
- Connecting to a Profile system with two disk recorder boards 2-6, 2-9
- Connector Pin-outs, SCSI-2 3-28
- Creating a File System 2-12

D

- Disk Activity Indicators 3-5
- Disk Activity Indicators, Troubleshooting
 - Disk Activity Indicators 3-5
- Disk Drive LEDs Cable, Removal and Replacement 3-12
- Disk Drive, Removal and Replacement 3-8
- Disk Tray Cover, Removal 3-14

E

- Electrical Characteristics

Power Source 1-5

- Electrical Specifications 1-5
- EN55022 Class A Warning xi
- Environmental Criteria 1-7
- Exterior, Cleaning 3-2

F

- Fan Fault Indicator, Troubleshooting 3-5
- Fan, Removal and Replacement 3-24
- FCC Emission Control xi

G

- General Safety Summary ix
- Grass Valley Group Product Support iii

I

- Indicators
 - Disk Activity 3-5
 - Fan Fault 3-5
 - Power On 3-4
 - System Fault 3-5
- Indicators, front panel 1-4
- Installing 2-1
- Interior, Cleaning 3-2
- Introduction 1-1

L

- LED Board, Removal and Replacement 3-10
- Line In Cable, Removal and Replacement 3-21

M

- Maintenance 3-2
 - Changing the Air Filter 3-3
 - Cleaning 3-2
 - Cleaning the Air Filter 3-3
- Making Cable Connections 2-6
- Manual Organization 1-2
- Mechanical Specifications 1-6
- Mounting the PDX 218 2-5
- Mounting the Slides in the Rack 2-2



O

Organization of the Manual 1-2

P

- PDX218, Creating a File System 2-12
- PDX218, Storage Capacity 1-3
- Power Connections
 - Power Source 2-10
 - Source Power Frequency and Ranges 2-10
- Power LED Cable, Removal and Replacement 3-11
- Power On Indicator, Troubleshooting 3-4
- Power Source Frequency 2-10
- Power Supply, Removal and Replacement 3-22
- Product Description 1-2
 - Features 1-4
 - Indicators, front panel 1-4
- Product Features 1-4

R

- Rack Mounting 2-1
 - Mounting the PDX 218 2-5
 - Mounting the Slides in the Rack 2-2
 - Rack Slide Adjustments 2-5
- Rack Slide Adjustments 2-5
- Related Documentation 1-2
- Removal and Replacement Procedures 3-6
 - Disk Drive 3-8
 - Disk Drive LEDs Cable 3-12
 - Disk Tray Cover 3-14
 - Fan 3-24
 - LED Board 3-10
 - Line In Cable 3-21
 - Power LED Cable 3-11
 - Power Supply 3-22
 - SCSI Cable 3-16
 - SCSI Distribution Board 3-26
 - SCSI Distribution Board Power Cable 3-18
 - Switch Cable 3-20
 - Top Cover 3-13
- Removing the Front Panel Bezel and Air Filter 3-8
- Replaceable Parts 3-6

Replacing the Front Panel Bezel and Air Filter 3-8

S

- Scope, Manual 1-1
- SCSI cable, Removal and Replacement 3-16
- SCSI Distribution Board, Removal and Replacement 3-26
- SCSI-2 Connector 3-28
- Service 3-1
- Service Safety Summary xv
- Source Power Ranges 2-10
- Specification
 - Electrical Characteristics
 - Power Source 1-5
- Specifications 1-5
 - Definition of Terms Used in Tables 1-5
 - Electrical 1-5
 - Environmental Criteria 1-7
 - Mechanical 1-6
- Specifications, Electrical 1-5
- Specifications, Mechanical Characteristics 1-6
- Storage Capacity 1-3
- Switch Cable, Removal and Replacement 3-20
- System Fault Indicator, Troubleshooting 3-5

T

- Top Cover, Removal 3-13
- Troubleshooting 3-4
 - Fan Fault Indicator 3-5
 - Power On Indicator 3-4
 - System Fault Indicator 3-5