



grass valley

A **BELDEN** BRAND

EC 2-100

2-INCH OCULAR VIEWFINDER FOR LDX 100 SERIES

User's Guide

13-00095-000

2021-03-11

www.grassvalley.com

FCC Compliance

This product generates, uses, and can radiate radio frequency energy and if not installed and used in accordance with the instructions, may cause interference to radio communications. It has been tested and found to comply with the limits for a class A digital device pursuant to part 15 of the FCC rules, which are designed to provide reasonable protection against such interference when operated in a commercial environment. Operation of this product in a residential area is likely to cause interference in which case the user at his own expense will be required to take whatever measures may be required to correct the interference.

Patent Information

This product may be protected by one or more patents. For further information, please visit: www.grassvalley.com/patents/

Copyright and Trademark Notice

Copyright © 2020, Grass Valley Canada. All rights reserved.

Grass Valley, EC 2-100 are trademarks or registered trademarks of Grass Valley Canada. Grass Valley Canada, and other parties may also have trademark rights in other terms used herein.

Terms and Conditions

Please read the following terms and conditions carefully. By using Broadcast Equipment documentation, you agree to the following terms and conditions.

Grass Valley hereby grants permission and license to owners of Broadcast Equipment to use their product manuals for their own internal business use. Manuals for Grass Valley products may not be reproduced or transmitted in any form or by any means, electronic or mechanical, including photocopying and recording, for any purpose unless specifically authorized in writing by Grass Valley.

A Grass Valley manual may have been revised to reflect changes made to the product during its manufacturing life. Thus, different versions of a manual may exist for any given product. Care should be taken to ensure that one obtains the proper manual version for a specific product serial number.

Information in this document is subject to change without notice and does not represent a commitment on the part of Grass Valley.

Warranty information is available from the Legal Terms and Conditions section of Grass Valley's website (www.grassvalley.com).

Title	EC 2-100 User's Guide
Part Number	13-00095-000
Revision	2021-03-11, 11:07

Cautions for LCD and TFT Displays



Excessive usage may harm your vision. Rest for 10 minutes for every 30 minutes of usage.

If the LCD or TFT glass is broken, handle glass fragments with care when disposing of them. If any fluid leaks out of a damaged glass cell, be careful not to get the liquid crystal fluid in your mouth or skin. If the liquid crystal touches your skin or clothes, wash it off immediately using soap and water. Never swallow the fluid. The toxicity is extremely low but caution should be exercised at all times.

Environmental Information

European (CE) WEEE directive.



This symbol on the product(s) means that at the end of life disposal it should not be mixed with general waste.

Visit www.grassvalley.com for recycling information.

Grass Valley believes this environmental information to be correct but cannot guarantee its completeness or accuracy since it is based on data received from sources outside our company. All specifications are subject to change without notice.

If you have questions about Grass Valley environmental and social involvement (WEEE, RoHS, REACH, etc.), please contact us at environment@grassvalley.com.

Safety and EMC Standards

This equipment complies with the following standards:

Safety Standards



Information Technology Equipment - Safety Part 1

IEC62368-1:2018

Safety of Information Technology Equipment Including Electrical Business Equipment.

EMC Standards

This unit conforms to the following standards:

EN55032:2012 + C2:2013 (Class A)

Electromagnetic Compatibility of multimedia equipment - Emission requirements

EN55103-2:2009 (Environment E2)

Electromagnetic Compatibility, Product family standard for audio, video, audio-visual and entertainment lighting control apparatus for professional use. Part 2. Immunity

FCC / CFR 47:Part 15 (Class A)



WARNING

This equipment is compliant with Class A of CISPR 32. In a residential environment this equipment may cause radio interference.

Federal Communications Commission Rules Part 15, Subpart B

Caution to the user that changes or modifications not expressly approved by the party responsible for compliance could void the user's authority to operate the equipment.

following the provisions of:

- the Low Voltage directive 2014/35/EU
 - the EMC directive 2014/30/EU
-



Note

This equipment has been tested and found to comply with the limits for a Class A digital device, pursuant to part 15 of the FCC Rules. These limits are designed to provide reasonable protection against harmful interference when the equipment is operated in a commercial environment.

This equipment generates, uses, and can radiate radio frequency energy and, if not installed and used in accordance with the instruction manual, may cause harmful interference to radio communications.

Operation of this equipment in a residential area is likely to cause harmful interference in which case the user will be required to correct the interference at his own expense.

toc

Table of Contents

1 Introduction	1
Overview.....	1
Key features.....	1
2 Installation.....	3
Mounting the viewfinder	3
Positioning the viewfinder	4
Horizontal.....	4
Angular	5
Lateral	5
Distance viewing	5
3 Operation.....	7
Controls.....	7
Rear panel	7
Front panel	9
Indicators	10
LED indicators.....	10
On screen indicators.....	12
On screen markers	13
On screen (framing) boxes.....	13
Operational functions	14
Mono	14
Ext1.....	14
Ext2.....	14
VF Zoom	14
Text.....	14
Call	14
Viewfinder detail	14
Focus Assist.....	15
Zebra	15
4 Viewfinder setup	17
Menu contents	17
Entering the menu	17
Diagnostics menu (DIAG)	18
Configuration menu (CONFIG)	18
Indicator adjustment submenu (INDADJ).....	18
Color menu (COLOR)	19

Viewfinder status information.....19

Appendix A Specifications 21

General21
Screen21
Dimensions22
Accessories.....22
Connector.....23

Contact Us 25

1 Introduction

Overview

The EC 2-100 is a high performance color ocular viewfinder specially designed for Grass Valley's LDX 100 Series cameras. It is part of a line of state-of-the-art color viewfinders and is very feature-rich with an intuitive user interface. The viewfinder has a stylish look and compact design.

The EC 2-100 offers the best possible image performance, high-speed response time, QHD resolution of 960 x 540 pixels and a diagonal display size of 2.0 in (5.1 cm). The controls are easy and flexible, similar to the larger 7-inch viewfinder. It comes with two assignable user buttons and a -2.7 to +1.3 dioptres compensation range.

Key features

- Stylish look and compact design
- High brightness and contrast ratio
- Easy and flexible to use
- Brightness, contrast and peaking adjustment with rotary controls
- Color/monochrome picture switchable
- Tally on-low-off switch
- Operator-only tally indicator
- Underscan mode for full picture visibility off-shoulder
- Two assignable buttons
- Diopter compensation range

2 Installation

Mounting the viewfinder

To mount the viewfinder on top of the camera adapter proceed as follows:

- Loosen locking ring **(2)** of viewfinder support bracket **(1)** at the front of the camera handgrip. (As seen from the rear of the camera, turning the locking ring counterclockwise moves it towards the handgrip.)
- Push the locking pin **(3)** in and slide the viewfinder onto the viewfinder support bracket **(1)**.
- Tighten the locking ring **(2)** by turning it clockwise (as seen from rear) so that the viewfinder is mounted securely to the support.

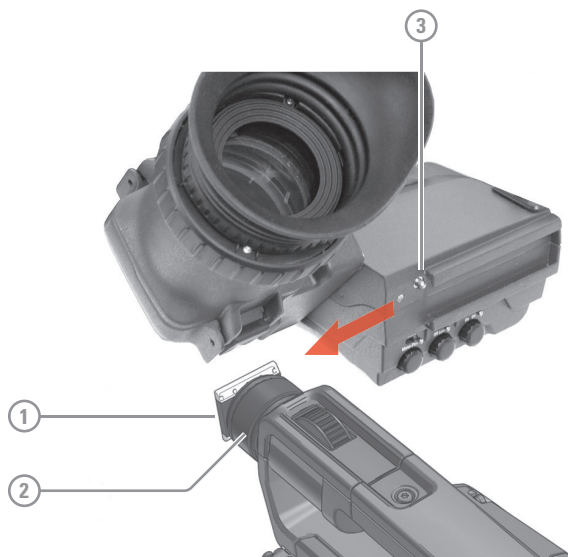

- Connect the viewfinder cable to the viewfinder connector socket **(4)** under the recess at the right side of the camera.
- Guide the cable through the upper cable clip **(4a)** and down along the cable holder **(4b)**.
- Attach the microphone holder **(5)** onto the viewfinder and secure it with the knurled screw **(6)** on top.

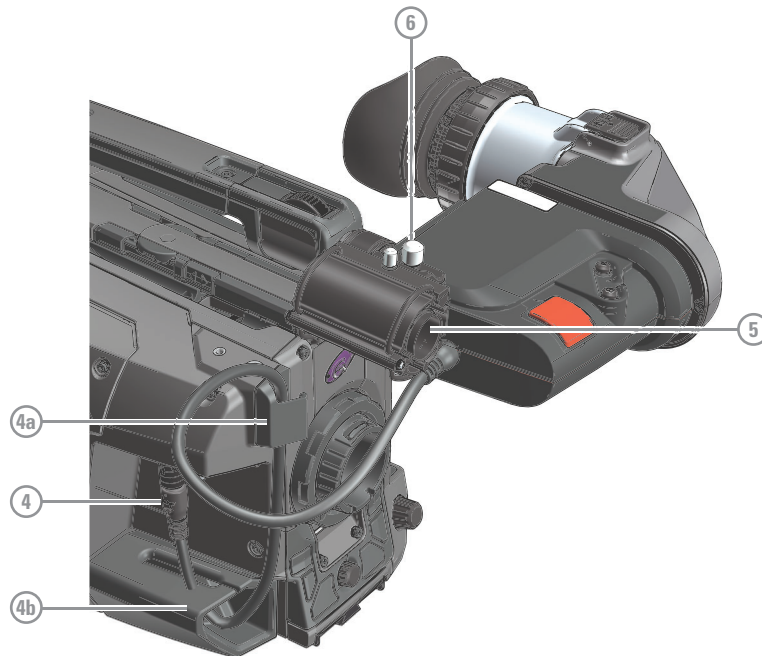

Positioning the viewfinder

Horizontal

The horizontal position of the viewfinder can be adjusted as follows to suit your preferences:

- Loosen the locking ring **(1)**. As seen from the rear of the camera, turning the locking ring counterclockwise moves it towards the handgrip.
- Slide the viewfinder horizontally along the rail to the desired position.
- Tighten the locking ring **(1)** again by turning clockwise.

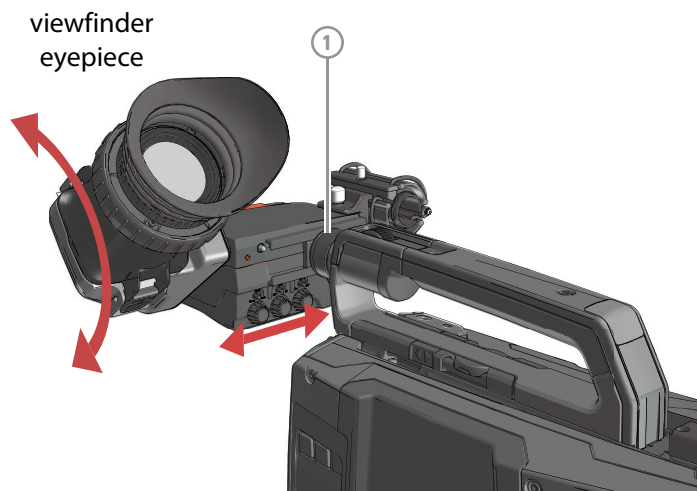

Angular

Grab the viewfinder eyepiece with your hand and rotate it to the desired angle.

Lateral

The viewfinder can be positioned backwards and forwards along the camera axis (lateral):

- Loosen the locking disc **(1)** by turning it counterclockwise using your thumb and index finger.
- Press both sides of the handgrip clip **(2)** using your thumb and index finger and with the lever pressed in, move the handgrip (with viewfinder) back or forth.
- When the desired position is reached release the clip. Note: the rail on the camera body has indents so make sure to place the handgrip is placed at a fixed position.
- Tighten the locking disc **(1)** by turning it clockwise.

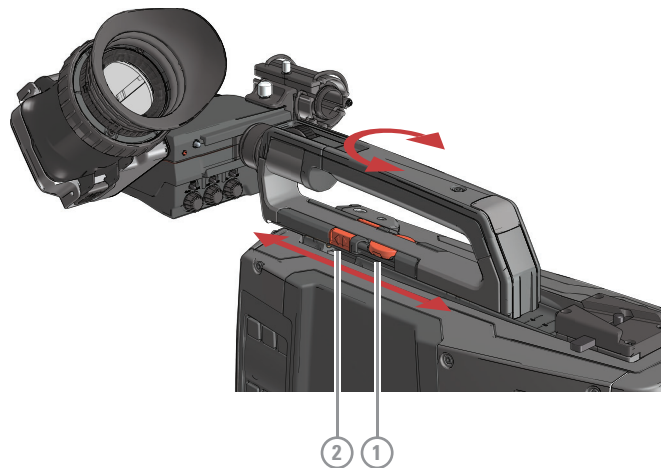

Note

Moving the handgrip also changes the weight balance of the camera. Make sure to balance the camera with the lens mounted and the cables attached.

Distance viewing

The viewfinder display can also be viewed from a distance :

- Push down the bottom clip **(4)** below the eyepiece and swing it free of the associated clip. The eyepiece can also be swung downwards; push down the top clip to release the eyepiece and swing it downwards.

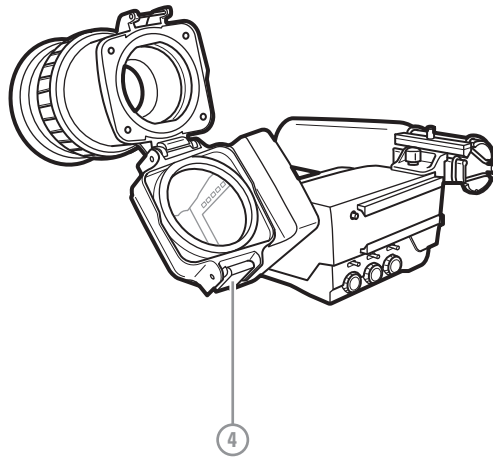

Note

Handle the eyepiece with care when folded back—its position is not secured.

3 Operation

Controls

Rear panel

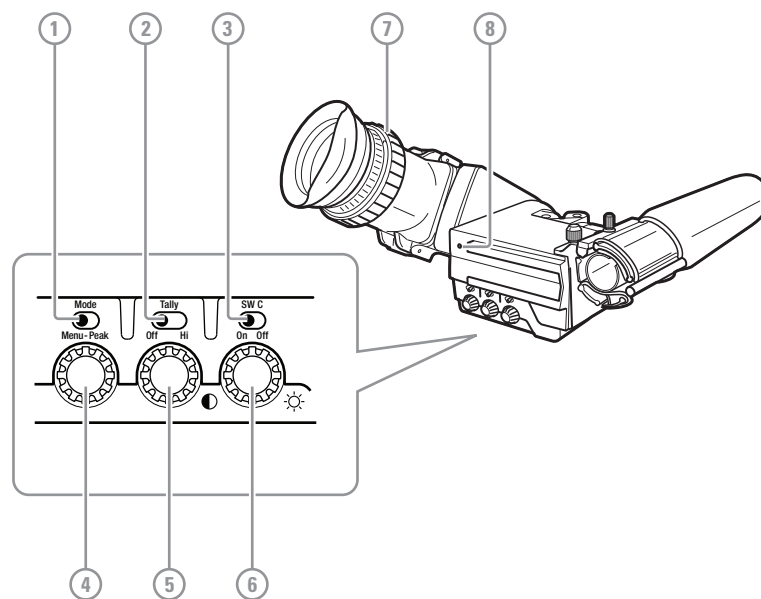

① Mode switch

This switch determines the function of the Menu-Peak rotary control below. Set the Mode switch to the right (Peak) to adjust peaking level. Set the Mode switch to the left (Menu) to use the rotary for menu navigation.

② Tally switch

This switch is used to control the tally indicators at the front of the viewfinder and the rear of the handgrip. The toggle switch has three settings: Off, Low (middle position) and Hi.

When the switch is set to the Off position, the tally indicator does not light even when the camera is On Air.

③ Switch C (underscan)

Set this toggle switch to On to see an underscan or scaled down (to approximately 85% of the area) picture in the viewfinder. This allows for a greater viewing distance from the

eyepiece. A blue border around the picture and the message “underscan” appear. Set the switch to Off to return to the original picture.

④ **Menu-Peak control**

When the Mode switch (1) is set to Peak, this rotary control adjusts the peaking level (sharpness) of the viewfinder picture.



Note

It may be necessary to reduce peaking when camera gain is set to high values.

When the Mode switch (1) is set to Menu, the rotary is used for navigating the viewfinder menu. Refer to [Viewfinder setup](#), on page 17 for more information about the menu and to navigate it.

⑤ **Contrast control**

Turn this rotary control clockwise to adjust the contrast of the viewfinder picture according to your preferences. The range runs from 0 (low contrast) to 99 (high contrast).

⑥ **Brightness control**

Turn this rotary control clockwise to adjust the brightness of the viewfinder picture according to your preferences. The range runs from 0 (very dark) to 99 (very bright).

⑦ **Dioptr adjustment ring**

The dioptr of the viewfinder can be adjusted to suit your eyesight by turning the dioptr adjustment ring. Turn to the right for negative dioptr values, turn to the left for positive values.

⑧ **Rear tally indicator**

This indicator lights to indicate that the camera is On Air. This indicator has the same function as the front tally indicator.

Front panel

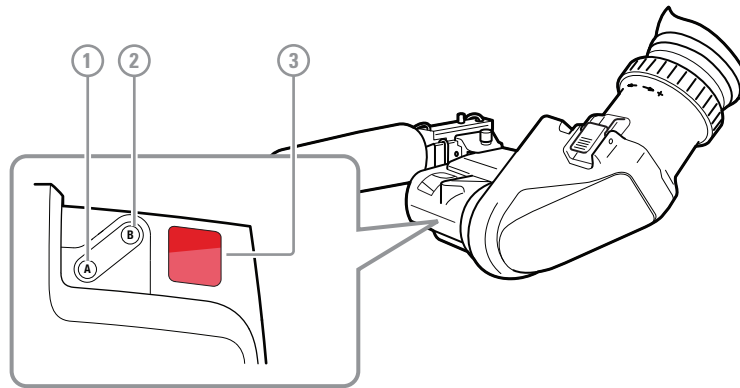

① User button A

This user button can be assigned to many different functions. Refer to the section below for more details about assigning.

② User button B

This user button can be assigned to many different functions. Refer to the section below for more details about assigning.

Assigning user buttons

In the camera menu, go to the *Operator Toolbox > User buttons > Viewfinder* menu and use *Btn A* or *BtnBA* to assign a function one of the buttons. Use *Btn A Mode* and *Btn B Mode* to toggle between momentary (Mom) and alternating (Alt) switching mode for each button.



Note

When a user button is assigned to Call, its switching mode is automatically set to *momentary*.

③ Front tally indicator

This indicator (and one at the rear of the handgrip of the camera) lights to indicate that the camera is On Air.

Indicators

LED indicators

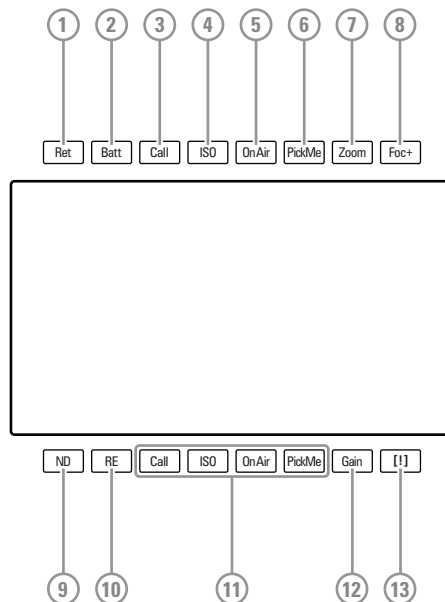

① **Return indicator**

Lights when a return video channel is switched on in the camera.

② **Battery power indicator**

Lights if the camera input voltage is too low (when using a battery).

③ **Call indicator**

The green LED lights to attract attention when a Call signal is activated.

④ **ISO indicator**

The yellow LED lights to indicate that the camera is currently in ISO mode (yellow On Air or Isolate)

⑤ **On Air indicator**

The red LED lights to indicate that the camera is currently On Air.

⑥ **PickMe indicator**

This yellow LED lights when a PickMe signal is activated.

⑦ **Zoom indicator**

Lights when the viewfinder Zoom function is on.

⑧ **Focus Assist indicator**

Lights when the focus assist function is on (turn on in the camera menu).

⑨ **Range Extender indicator**

Lights when a range extender is selected.

⑩ **ND filter indicator**

Lights when an ND (neutral density) optical filter is selected.

⑪ **Studio signalling indicators**

Mirrored indicators from the top row (Call, ISO, On Air and PickMe) for improved viewing range.

⑫ **Gain indicator**

Lights when gain is lower than 0 dB or higher than +3 dB

⑬ **Non-standard indicator**

The non-standard video settings indicator lights when one of the following conditions occur:

- Exposure time is not set to the nominal value.
- Black Stretch is on.
- Extended Auto Iris is on.
- AWC (continuous automatic white balance) or FL (fluorescent) color temperature is on.

On screen indicators

In the camera menu, go to the *Indicators* submenu to select the indicators you want to see in the viewfinder screen:

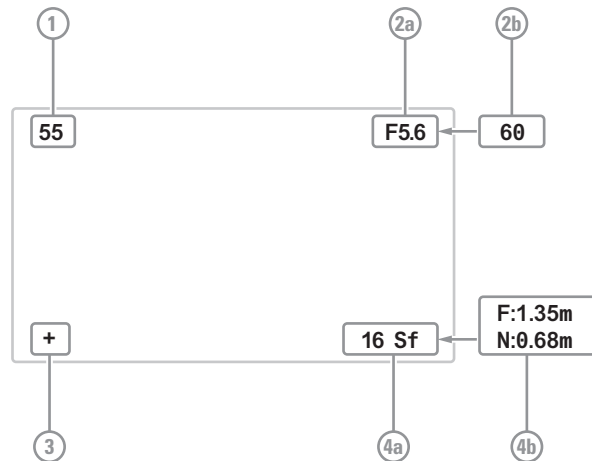

① Zoom indicator

Indicates the percentage to which the lens has been zoomed out or in, ranging from 0 (wide) to 99 (tele). It shows **50** if the lens does not support this feature.

②a Iris indicator

Shows the iris opening (or F-value) of the lens. Typical range is F1.4 to F25. The indicator shows **Closed** when the lens is closed or capped.

②b Focus indicator

Shows the percentage of the lens focus distance. Typical range is from 0 (close-up) to 99 (infinity).

③ Precision Focus (PF) indicator

Shows the Precision Focus indicator (if supported by the lens).

④a Filter indicator

Shows the selected optical filters (ND and FX).

④b Depth of Field (DOF) indicator

Shows Depth of Field of the current lens position. F = Far limit in meters, N = near limit in meters.

On screen markers

In the camera menu, go to the *Indicators > Markers* submenu to select the indicators you want to see in the viewfinder screen:

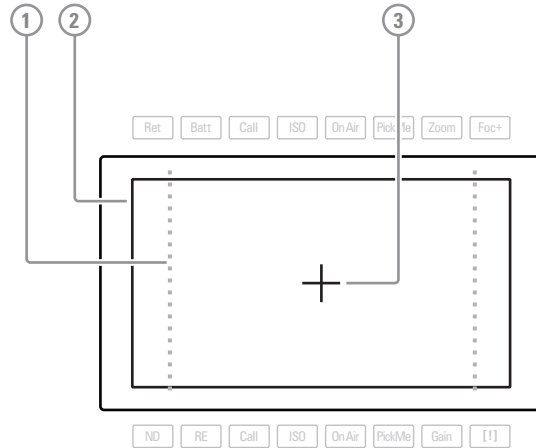

① Cadre

A dotted white line or a shaded area that shows the limits of a 4:3 (15:9 or 14:9) picture.

② Safe area

Encloses an area that represents 80% of the whole viewfinder picture area. This is the minimum screen area.

③ Centre cross

Marks the centre of the picture.

On screen (framing) boxes

You can use up to two boxes. They are a useful feature to help focussing and framing while shooting. Three box types are available:

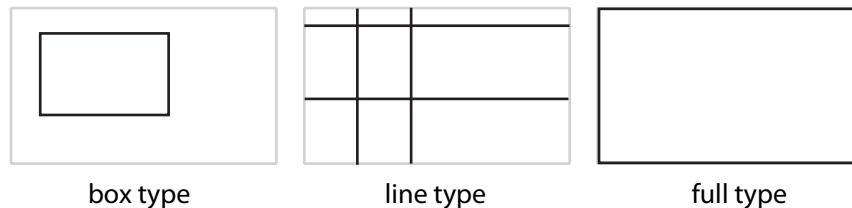

In the camera menu, go to the *Indicators > Box* submenu to set up the boxes.

Operational functions

Many viewfinder functions are set up in the camera system menu and then be assigned to one of the two buttons at the front of the viewfinder. Refer to your camera user's guide for more information on how to use the camera system menu. T

Mono

Switches the viewfinder to monochrome mode. Select the source (Y, R, G, B or -G) in the viewfinder setup menu. When the camera color bar is switched on, the viewfinder returns to color mode.

Ext1

Displays external video channel 1 in the viewfinder.

Ext2

Displays external video channel 2 in the viewfinder.

VF Zoom

Zooms in to the center of the image for an uncropped (100%) view. The actual zoom factor depends on the selected camera video mode. When the Zoom function is in use, many of the viewfinder markers are switched off to improve the clarity of the display.

The Zoom indicator in the viewfinder lights when the zoom function is active.

Text

Removes all text items from the viewfinder image. This includes menu and message texts and camera indicators. Markers and cadres are not removed from the image. Press again to restore text.

Call

Press the button to activate the studio Call signal. The green Call indicators on the viewfinder light.

Viewfinder detail

The viewfinder detail function emphasizes edges in the viewfinder image, resulting in sharpness perception. Go to the camera system menu to select the VF detail mode and the detail level.

Focus Assist

The Focus Assist function adds a crawling effect in the viewfinder to objects in sharp focus. The FOC+ indicator in the viewfinder lights when this function is active. Go to the camera system menu to turn Focus Assist on or off.

Zebra

The Zebra function displays a zebra (striped) pattern in the viewfinder in areas where highlights occur. This diagonal line pattern warns you that the area affected has risen above a preset level of the full scale video exposure. Go to the camera system menu to turn Zebra on or off and to set the video levels at which Zebra works.

4

Viewfinder setup

Menu contents

Entering the menu

Some specific viewfinder functions can be set up in the viewfinder menu. Enter the menu as follows:

- Make sure the mode switch on the rear panel is set to Menu (left position).
- Press the menu rotary to open the menu. A black bar with menu items appears at the bottom of the viewfinder screen.
- Use the menu rotary to navigate to the PREV/NEXT item at the right side of the screen.
- Press the rotary to open a list of submenus. The PREV/NEXT item is blinking.



- Turn the menu rotary to loop through the submenus. The submenus are shown on the bottom bar.
- Press the menu rotary to leave the list and enter the selected submenu.
- Turn the menu rotary to loop through the items in the menu.
- Press to change the value of the selected item. Items with toggle values are changed immediately. Items with select values start blinking and their value can be changed by turning the rotary. Pressing stores the current value.
- When you are done making changes, navigate to the EXIT MENU item at the left side of the screen. Press to leave the viewfinder menu. The black bar disappears.

The following tables show the items and functions that can be set up in the viewfinder setup menu:

Diagnostics menu (DIAG)

Item	Value(s)	Description
EXIT	DIAG	Exits the diagnostics menu.
STATUS	INFO	Enters the viewfinder status information screen. Refer to Viewfinder status information , on page 19.
—	—	—
LCD Temp	nn C	Info: shows the current LCD screen temperature in degrees celsius.
Format	<video formats>	Info: shows the current video format.
VF Temp	nn C	Info: shows the current viewfinder operating temperature in degrees celsius.
PREV ↑	NEXT ↓	Selects a menu from the list.

Configuration menu (CONFIG)

Item	value(s)	Description
EXIT	CONFIG	Exits the configuration menu.
IND	ADJUST	Push to enter the indicator adjustment submenu; see below.
—	—	—
FACTORY	RESET	Resets the viewfinder's settings to their factory defaults. The factory defaults are shown in the default column.
—	—	—
NoSignal	Black, Input, Bars	Selects signal when no camera signal is present (for example during start-up).
PREV ↑	NEXT ↓	Selects a submenu from the list.

Indicator adjustment submenu (INDADJ)

Item	Value(s)	Description
EXIT	INDADJ	Exits the indicator adjustment menu. The set indicator level is stored.
IndLvl	Low, Med, High	Selects the indicator level for the viewfinder LED indicators.
RearTlly	Ena, Dis	Enables or disables the viewfinder rear tally indicator.

Color menu (COLOR)

Item	Value(s)	Description
EXIT	COLOR	Exits the color menu.
—	—	—
—	—	—
—	—	—
Satur	0..99 (50)	Sets the color saturation level.
ColTemp	3200K..9500K (6500K)	Sets the viewfinder color temperature.
PREV ↑	NEXT ↓	Selects a menu from the list.

Viewfinder status information

The status information screen shows information about the viewfinder's internal hard- and software components. This information can be useful when contacting Grass Valley service support. Press EXIT to leave this screen.

Viewfinder Status Information						
Type: EC 2-100			PID: nnnn			
	12NC	Status	Date	PID		
Main Brd:	0052 200 05701	St:00	St:00	PID12		
ID Brd:	3922 406 56031	St:00	St:00	PID12		
UI Brd:	0052 200 09001	St:00	St:00	PID12		
	12NC	Status	Date	Valid		
Package:	0053 800 00801	v01.99	1/1/2020	Ok		
Content:						
-Conf.Sw	0052 800 02101	v01.99	1/1/2020	Ok		
-Firmware	0050 400 01901	v01.99	1/1/2020	Ok		
-App1.Sw	0052 800 02001	v01.99	1/1/2020	Ok		
Configuration software active:		Yes				
EXIT						

A Specifications

General

Dimensions (W x H x D)	248 x 76 x 219 mm (9.8 x 3.0 x 8.6 in)
Weight (approx.)	0.90 kg (2.0 lbs)
Operating temperatures	-20 to +45 °C (-4 to +113 °F)
Storage temperatures	-25 to +70 °C (-13 to +158 °F)
Power supply	+10.5 to +17 VDC (supplied by the camera)
Power consumption (typ.)	3.9 W (heater off), 5.7 W (heater on)
Input signals	uses 1080p@4:4:4 YCbCr 10 bits video in 50/59 Hz frame rate as delivered by the LDX100 series cameras in all operational camera video modes
Controls	Brightness, Contrast and Menu/Peaking rotary controls, 2 assignable user buttons
Indicators	ISO, On-Air and Call + 2 On-Air lamps (adjustable)

Screen

Diagonal screen size	2.0 inch (5.1 cm)
Color depth	16.7 million colors (8 bit color)
Total display area	960 (H) x 540 (V) pixels (QHD resolution)
Display aspect ratio	16:9
Response rate ($T_{on} + T_{off}$)	16 ms
Eyepiece adjustment range	-2.7 to +1.3 dioptres
Pixel pitch	0.047 x 0.047 mm
Luminance (typ.)	250 Cd/m ²
Contrast ratio (typ.)	200:1
Color temperature	6500 K (adjustable)

Dimensions

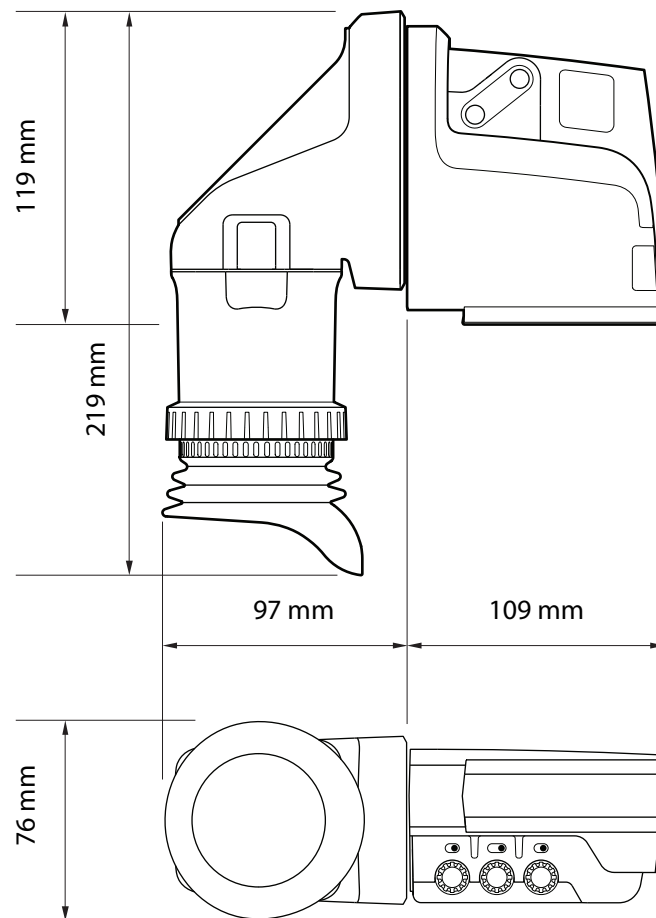

Accessories

- Microphone holder (supplied)

Connector

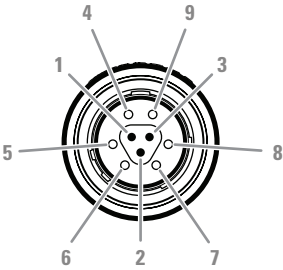

9-pin Fischer
male/female lead
connector

Pin	Description
1	USB - (I ² C control data)
2	Drain (Lane 1+2)
3	USB + (I ² C control data)
4	VF Power +
5	VF video (Lane 1 +)
6	VF video (Lane 1 -)
7	VF video (Lane 2 +)
8	VF video (Lane 2 -)
9	GND

manufacturer code:
Fischer MiniMax Series MP11ZL08 2007
BK1 Z1AS



Grass Valley Technical Support

For technical assistance, contact our international support center, at 1-800-547-8949 (US and Canada) or +1 530 478 4148.

To obtain a local phone number for the support center nearest you, please consult the Contact Us section of Grass Valley's website (www.grassvalley.com).

An online form for e-mail contact is also available from the website.

Corporate Head Office

Grass Valley
3499 Douglas-B.-Floreani
St-Laurent, Quebec H4S 2C6
Canada
Telephone: +1 514 333 1772
Fax: +1 514 333 9828
www.grassvalley.com