

LDK 20(S)

Studio Camera

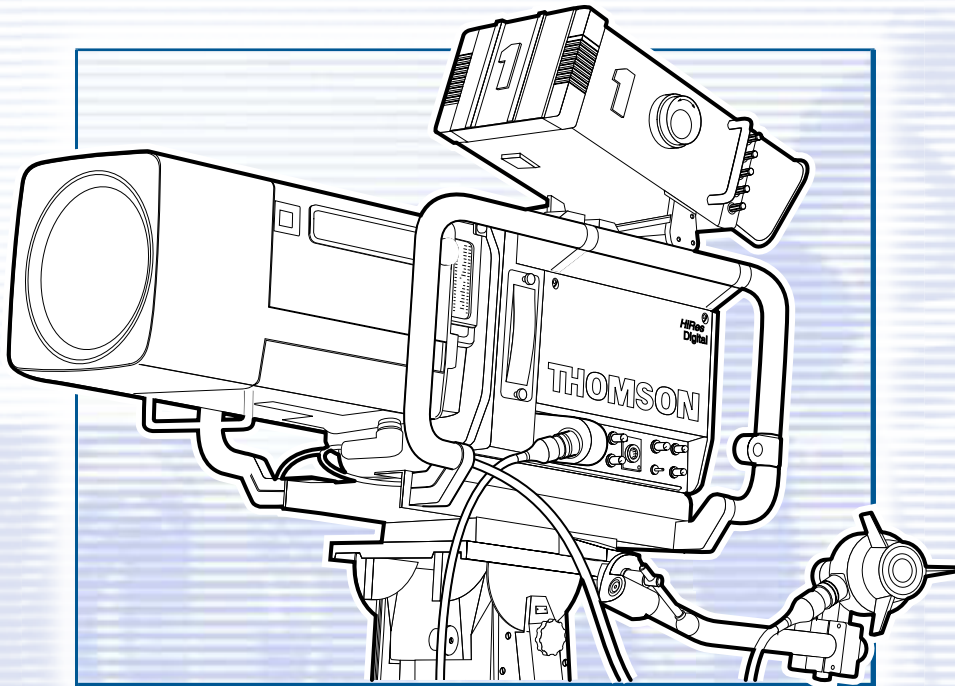

Technical Manual

3922 496 48591 St.00

Declaration of Conformity

We, Thomson Broadcast Solutions Nederland B.V., Kapittelweg 10, 4827 HG Breda, The Netherlands declare under our sole responsibility that this product is in compliance with the following standards:

- EN60065 : Safety
- EN55103-1 : EMC (Emission)
- EN55103-2 : EMC (Immunity)

following the provisions of:

- a. the Safety Directives 73/23/EEC and 93/68/EEC
- b. the EMC Directives 89/336/EEC and 93/68/EEC

FCC Class A Statement

This product generates, uses, and can radiate radio frequency energy and if not installed and used in accordance with the instructions, may cause interference to radio communications.

It has been tested and found to comply with the limits for a class A computing device pursuant to Subpart J of part 15 of FCC rules, which are designed to provide reasonable protection against such interference when operated in a commercial environment.

Operation of this product in a residential area is likely to cause interference in which case the user at his own expense will be required to take whatever measures may be required to correct the interference.

Copyright

Für diese Unterlage behalten wir uns alle Rechte vor (Gemäß DIN 34). Technische Änderungen im Zuge der Weiterentwicklung vorbehalten.

Copying of this document and giving it to others, and the use or communication of the contents thereof, are forbidden without express authority. Offenders are liable to the payment of damages. All rights are reserved in the event of the grant of a patent or the registration of a utility model or design. Liable to technical alterations in the course of further development.

Toute communication ou reproduction de ce document, toute exploitation ou communication de son contenu sont interdites, sauf autorisation expresse. Tout manquement à cette règle est illicite et expose son auteur au versement de dommages et intérêts. Tous nos droits sont réservés pour le cas de la délivrance d'un modèle d'utilité. Sous réserve de modification au cours de l'évolution technique.

LDK 20(S) Studio Camera

Technical Manual

Contents

About This Manual	II		
Safety Instructions	1-1	Adjustments	4-1
Safety Summary	1-2	Introduction	4-2
Cautions and Warnings	1-2	Test Equipment	4-3
Earthing	1-3	Set-up Instructions	4-3
		Video Processor 1 Board	4-5
Installation	2-1	Digital Video Processor	4-10
Packing/Unpacking	2-2	Digital Video Processor	4-11
Local / Remote Power Supply	2-2	Digital Video Processor Subboard	4-12
Hardware Setup and Customization	2-3	Digital Video Processor Subboard	4-13
Test Sawtooth	2-4	Digital Video Processor	4-14
Lens matching	2-4	Digital Video Processor	4-15
Analogue Ch1-Ch2	2-5	Video Miscellaneous Board	4-17
External Aspect Ratio Switch	2-5	Sync./Shading Board	4-27
Dipswitch Settings	2-5	Video Miscellaneous Board	4-35
Viewfinder Cadre Indication	2-6	Encoder Board PAL	4-37
Audio / Intercom settings	2-7	Encoder Board NTSC	4-43
Private Data	2-8	Audio/Intercom LF Board	4-51
Connectors and Cables	2-9	Audio/Intercom LF Board RTS MODE	4-55
Specifications LDK20	2-14	Pre-Processor Board	4-57
Replacements	3-1	Drawings	5-1
Introduction	3-2	Block Diagram Power Signals	5-2
Printed circuit boards	3-2	Block Diagram Video Signals	5-3
Front module	3-3	Block Diagram Transmission Signals	5-4
Filterwheel Cassette	3-4	Block Diagram Control Signals	5-5
Power supply	3-4		

About This Manual

Service policy

The LDK 20(S) is a sophisticated camera containing state-of-the-art electronic components which are designed to provide long-life operation without the need for maintenance. With this in mind, the service policy of Thomson Multimedia Broadcast Solutions endeavours to ensure that help will be quickly on hand in the unlikely event of anything going wrong. The guiding principles of the Thomson Multimedia Broadcast Solutions first line maintenance philosophy are speed and cost effectiveness. First line maintenance is dedicated to keeping your camera operational, despite a fault, by module replacement and the replacement of minor mechanical parts by the user.

Purpose of this manual

The provision of correct information is the first step in ensuring the operational integrity of the camera. Information on the operation of the camera is to be found in the User's Guide.

This installation and first line maintenance manual is an integral part of the service policy. It ensures that you will be able to install and set-up your camera to meet the requirements of your environment. This information on the installation of the camera is contained in Section 2 of the manual. The remaining sections of the manual provide first line service information so that suitably qualified service personnel can detect and repair faults, normally by module replacement.

Because of the complexity of some of the components, second line service can only be carried out at the specially equipped service centres and information concerning second line maintenance is not supplied in this manual.

Intended audience

The manual is intended as a guide to those with a working knowledge of camera systems and installation techniques. The first line detection and repair of faults requires a general knowledge of test and measurement techniques.

Structure of this manual

The manual is divided into five sections:

Section 1: Safety Information.

Contains important safety information and should be read before carrying out any work on the camera.

Section 2: Installation.

Gives instructions on the integration of the camera into the operating environment and the customization of certain hardware functions

Section 3: Replacements.

Gives information on the replacement of components at first line level.

Section 4: Adjustments.

Contains the adjustment procedures to be followed to obtain the best performance from the camera.

Section 5: Drawings.

Contains block diagrams of the camera.

Section 1

Safety Instructions

This section outlines the precautions that must be taken into account when using the LDK 20(S) Studio Camera.

Contents

Safety Summary	1-2	Earthing	1-3
Cautions and Warnings	1-2		

This information is intended as a guide for trained and qualified personnel who are aware of the dangers involved in handling potentially hazardous electrical/electronic equipment. It is not intended to contain a complete list of all safety precautions which should be observed by personnel in using this or other electronic equipment.

The installation, maintenance and service of this equipment involves risks both to personnel and equipment and must be performed only by qualified personnel exercising due care.

Personnel engaged in the installation, operation, maintenance or servicing of this equipment are urged to become familiar with First Aid theory and practices.

During installation and operation of this equipment, local building safety and fire protection standards must be observed.

Before connecting the equipment to the power supply of the installation, the proper functioning of the protective earth lead of the installation needs to be verified.

Whenever it is likely that safe operation is impaired, the apparatus must be made inoperative and secured against any unintended operation. The appropriate servicing authority must then be informed. For example, safety is likely to be impaired if the apparatus fails to perform the intended function or shows visible damage.

This product has been designed and tested according to EN60065.

When performing service, be sure to read and comply with the warning and caution notices appearing in the manuals. Warnings indicate danger that requires correct procedures or practices to prevent death or injury to personnel. Cautions indicate procedures or practices that should be followed to prevent damage or destruction to equipment or property.

WARNING

THE CURRENT AND VOLTAGES PRESENT IN THIS EQUIPMENT ARE DANGEROUS. ALL PERSONNEL MUST AT ALL TIMES FOLLOW THE SAFETY REGULATIONS.

ALWAYS DISCONNECT POWER BEFORE REMOVING COVERS OR PANELS.

ALWAYS DISCHARGE HIGH VOLTAGE POINTS BEFORE SERVICING.

NEVER MAKE INTERNAL ADJUSTMENTS, PERFORM MAINTENANCE OR SERVICE WHEN ALONE OR WHEN FATIGUED.

IN CASE OF AN EMERGENCY ENSURE THAT THE POWER IS DISCONNECTED.

ANY INTERRUPTION OF THE PROTECTION CONDUCTOR INSIDE OR OUTSIDE THE APPARATUS, OR DISCONNECTION OF THE PROTECTIVE EARTH TERMINAL, IS LIKELY TO MAKE THE APPARATUS DANGEROUS. INTENTIONAL INTERRUPTION IS PROHIBITED.

FOR SAFETY REASONS THE CPU MUST BE MOUNTED IN A 19-inch RACK WHICH HAS SAFETY COVERS ACCORDING TO IEC65.

WHEN TWO CPUs ARE MOUNTED ABOVE EACH OTHER THE MINIMUM DISTANCE BETWEEN THEM MUST BE 50MM OR THE RACK MUST BE FORCE-AIR COOLED.

USE ONLY FUSES OF THE TYPE AND RATING SPECIFIED.

CAUTION

To prevent risk of overheating, ventilate the product correctly.

Connect the product only to a power source with the specified voltage rating.





Only connect a Triax cable from the LDK 6 camera family to an LDK 6 CPU. Never connect it to any other base station.

Never connect the Triax cable from a camera to a CPU of a different family; never connect the LDK family to the TTV family.

Do not allow system ground currents to exceed 1.5A in the outer shield of the triax cable or 0.2A in other cable shields.

It is strictly prohibited to short circuit the inner and outer shields of a triax cable used to connect a camera to a base station.

Earthing

Symbol	Colour	Explanation
	Red	High voltage terminal at which a voltage, with respect to an other terminal, exists or may be adjusted to 1000V or more.
	Yellow/Black	Live part.
	Yellow/Black	This marking indicates that the operator must refer to an explanation in the Instruction Manual, or that a specific component must be replaced by the component specified in the documentation for safety reasons.
	White/Black	Protective earth (ground) terminal.



Cathode ray tubes

Components marked  on the circuit diagram are critical for safety and include those specified to comply with X-ray emission standards for units using cathode ray tubes and those specified for compliance with various regulations regarding spurious radiation emission.

When servicing units that use cathode ray tubes (CRTs), the cathode ray tubes themselves, the high voltage circuits and related circuits are specifically chosen so that they comply with recognized codes pertaining to X-ray emission.

Consequently, when servicing, replace the cathode ray tubes and other parts with specified parts only. Do not attempt to modify these circuits as any unauthorized modification can increase the high voltage value and cause X-ray emission from the cathode ray tube.

Handle the cathode ray tube only when wearing shatterproof goggles and after discharging the high voltage completely.

The rear of a CPU has two separate screw terminals for protective earth  (PE) and video earth  (VE).

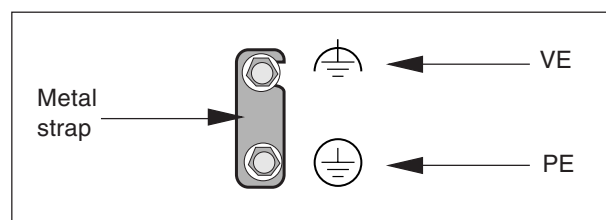

These are normally connected by a metal strap. The protective earth terminal is internally connected to the protective earth conductor of the power cable. If required, the central earth connection wire of the studio can be connected to terminal PE.

In normal circumstances the connection between the protective earth and the video earth should not be broken.

The metal strap may be removed only if the studio (or OB van) is equipped with separate protective and video earth systems. Under these circumstances the video earth terminal must be connected to the central functional earth potential (video earth) of the studio. This earth potential should have functional protective and noiseless earth (FPE) qualities as stated in the VDE regulation 0800/part2. A low impedance interconnection of both earth conductors must be provided at the central studio earthing point.

WARNING

THE UNIT MUST ALWAYS BE CONNECTED TO PROTECTIVE EARTH.

Mains Lead Wiring for UK Users

The wires in the mains lead are coloured in accordance with the following code:

GREEN AND YELLOW	-	EARTH
BLUE	-	NEUTRAL
BROWN	-	LIVE

As the colours of the wires in the mains lead of this apparatus may not correspond with the coloured markings identifying the terminals in your plug proceed as follows:

- The wire coloured GREEN AND YELLOW must be connected to the terminal on the plug marked with the letter E or by the safety earth symbol  or coloured GREEN or GREEN AND YELLOW.
- The wire coloured BROWN must be connected to the terminal marked with the letter L or coloured RED.
- The wire coloured BLUE must be connected to the terminal marked with the letter N or coloured BLACK.

Ensure that your equipment is connected correctly - if you are in any doubt consult a qualified electrician.

Section 2

Installation

This section provides information which is relevant when the camera is to be used for the first time. Packing and unpacking instructions together with information on the integration of the camera into your studio system are provided. The procedures for the customization of certain hardware functions and connector information is also provided.

Contents

Packing/Unpacking	2-2	Dipswitch Settings	2-5
Local / Remote Power Supply	2-2	Viewfinder Cadre Indication	2-6
Hardware Setup and Customization	2-3	Audio / Intercom settings	2-7
Test Sawtooth	2-4	Private Data	2-8
Lens matching	2-4	Connectors and Cables	2-9
Analogue Ch1-Ch2	2-5	Specifications LDK20	2-14
External Aspect Ratio Switch	2-5		

Packing/Unpacking

Inspect the shipping container for evidence of damage immediately after receipt. If the shipping container or cushioning material is damaged, it should be kept until the contents of the shipment have been checked for completeness and the units have been checked mechanically and electrically.

The shipping container should be placed upright and opened from the top. Remove the cushioning material and lift out the contents.

The contents of the shipment should be checked against the packing list. If the contents are incomplete, if there is mechanical damage or defect, or if the units do not perform correctly when unpacked, notify your Thomson Multimedia Broadcast Solutions sales or service centre within eight days. If the shipping container shows signs of damage or stress, notify the

carrier as well.

If a unit is being returned to Thomson Multimedia Broadcast Solutions for servicing, try to use the containers and materials of the original packaging. Attach a tag indicating the type of service required, return address, model number, full serial number and the return number which will be supplied by your Thomson Multimedia Broadcast Solutions service centre.

If the original packing can no longer be used, the following general instructions should be used for repacking with commercially available materials:

- Wrap unit in heavy paper or plastic.
- Use strong shipping container.
- Use a layer of shock-absorbing material around all sides of the unit to provide firm cushioning and prevent movement inside container.
- Seal shipping container securely.
- Mark shipping container FRAGILE to ensure careful handling.

Local / Remote Power Supply

The LDK 20 camera is delivered ready to operate in the remote mode. If the camera has to be used in the local (stand-alone) mode, carry out the following instructions to allow the power to be supplied via the mains power supply input connector on the right side connector panel:

- Disconnect the mains power supply or the triax cable, whichever is connected.

- Loosen two screws and remove the rear connector panel of the camera.
- Locate the remote/local switch - a large black plastic box.
- Set the switch to the local position. The camera is delivered with the switch in the remote position.
- Return the rear connector panel to its position.

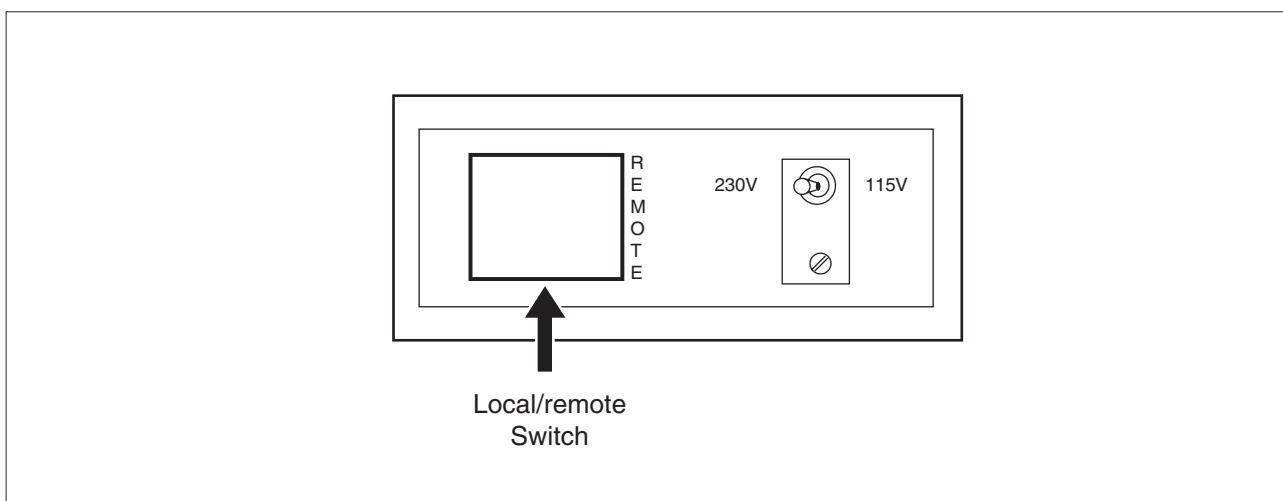

Hardware Setup and Customization

The camera is delivered in a ready-to-use state, however, there are occasions when it might be necessary to re-adjust some functions after, for example, fitting a new lens.

A large number of functions can be set-up using the control facilities of the menu system. In addition to this software set-up there are some functions which can be selected or adjusted internally in the camera. Refer to the next chapters for instructions.

Location of adjustments

Turn the two screws on the left side panel 90° counterclockwise and swing down the cover. Turn the two screws on the right side panel 90° counterclockwise and swing down the cover.

Unless mentioned otherwise the adjustments for hardware setup and customization are located at the side of the following modules:

- ❶ Front Module
- ❷ Video Processor 1
- ❸ Digital Video Processing
- ❹ Subboard DSP
- ❺ Sync. Shading
- ❻ Data Processor
- ❼ Power
- ❽ Video Miscellaneous
- ❾ Encoder
- ❿ Video Mux Ext-TP Rec
- ⓫ Audio/Intercom TX-Rec
- ⓬ RTS Power Miscellaneous

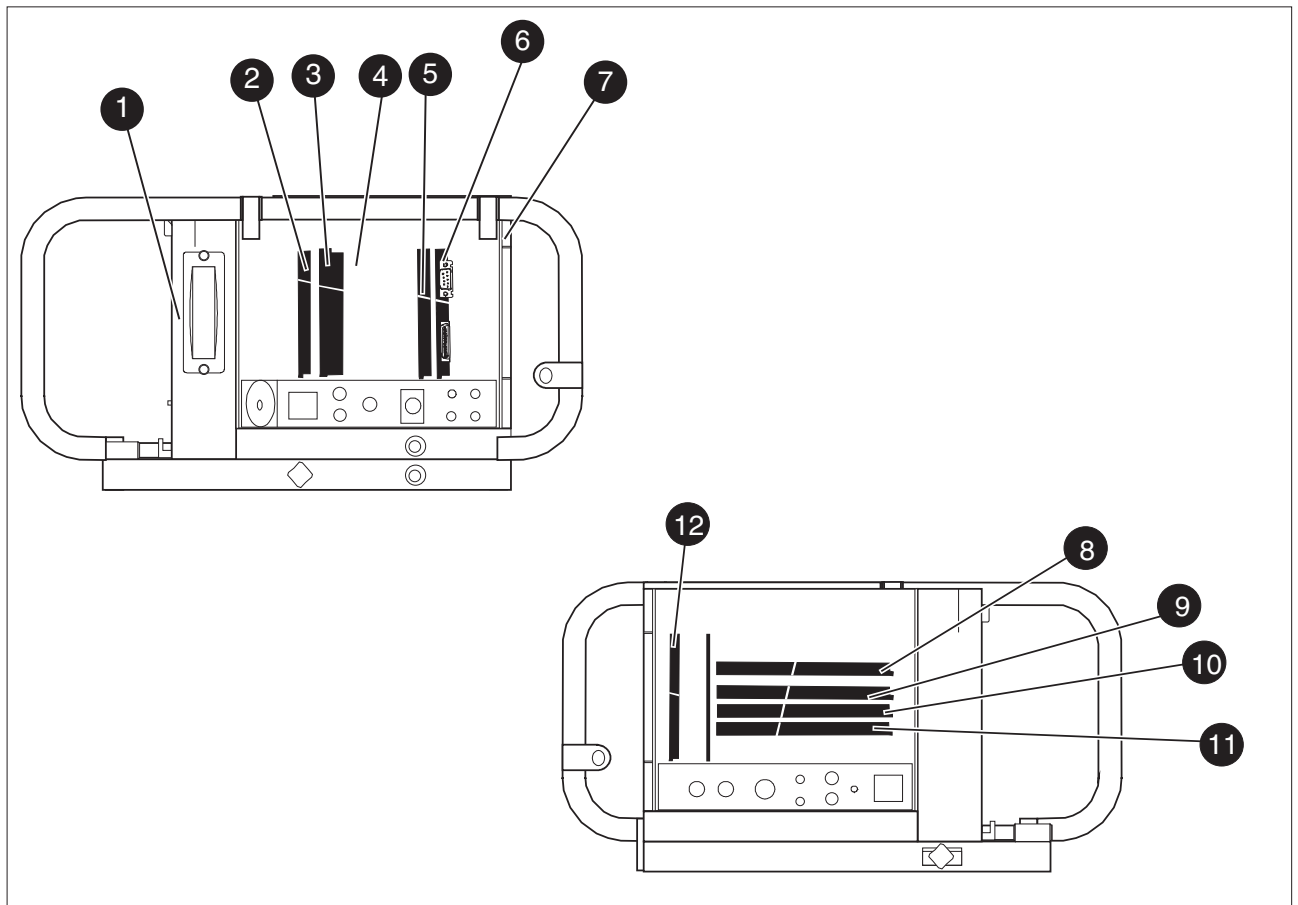

A test sawtooth signal is normally only used for adjustment procedures. Jumper X3 on Video processor 1 board provides a choice between two internal signals or an external signal.

Internal signals

Set jumper X3 to position BC to get the nominal sawtooth. This is used for checking amplitudes.

Set jumper X3 to position AB to get a small sawtooth (approximately 25% nom.). This small sawtooth is used for checking painting or colour temperature ranges.

External signal

To inject an external test signal first set jumper X3 to position CD (test input). Connect the external test signal to connector X4-1/2. The nominal value of this signal is 700 mV without sync.

The test sawtooth signal is switched on by means of the Operate menu of the camera or the Setup 1 menu of the MCP.

When a camera is supplied with a lens it is not necessary to perform any of the following adjustments as the lens is already matched to the camera. However, if you wish to change to a different type of lens or the lens is not supplied with your camera, back focus, white shading and auto iris adjustment procedures may have to be performed.

- Colour balance.
If required, perform the gain adjustment of the preprocessor board and/or white shading adjustment procedures, described in section 4.
- Auto Iris Adjustment
If a different lens either works too slow or overshoots too much with the auto iris control, adjust the potentiometer on the lens to obtain acceptable operation. Refer to the lens documentation.
- Back Focus Adjustment
To adjust the back focus of the lens refer to the documentation of the lens.

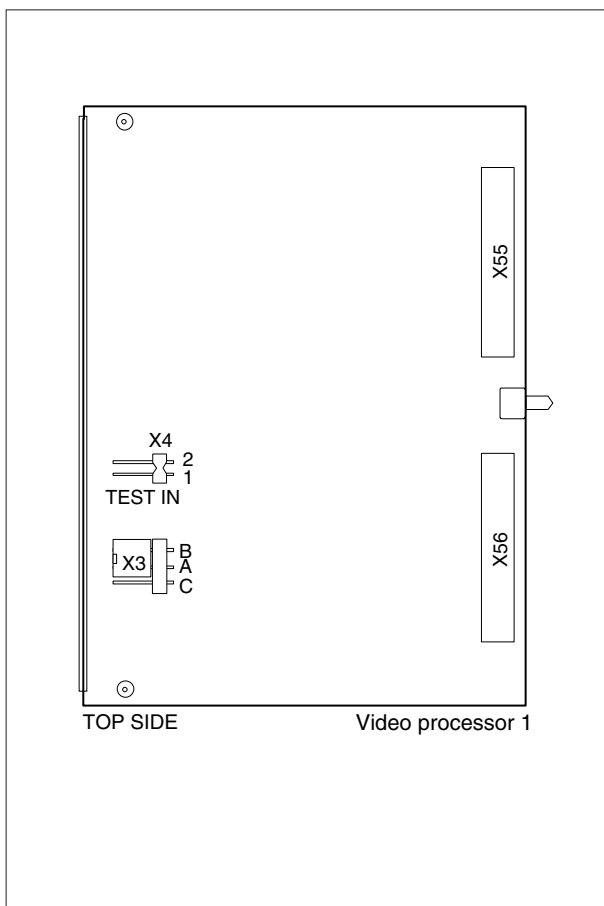

Two analogue channels (AN 0 and AN 1) are available from the base station to the camera via the triax cable and can be used to transmit L.F. signals. For example, joystick control or pan and tilt. The input signals are applied to the Auxiliary connector of the base station. The output signals are available on the Auxiliary connector of the camera. The input signal and output signal voltage is between 0 and 5Vdc.

The AN 1 channel is sometimes used for switching the aspect ratio. This is selected by means of the software. See next chapter for instructions.

On the Digital Video Processor 3922 406 84951 the following functions can be selected with dipswitches ZS110 and ZS111:

- ZS110-1 Leaking Pixel Corrector
- ZS110-2 Noise Reducer
- ZS110-3 HW Gamma Low Pass Filter
- ZS110-4 Contour Boost (Viewfinder)
- ZS111-1 Status Bar (only LDK20P) Focus value remains present.

External Aspect Ratio Switch

The analogue channel 1 (AN 1) input on the base station can be used to switch the aspect ratio. This allows multiple camera switching.

This function can be selected in the menu system of the camera or MCP. To select this function on the camera, set the Aspect ratio of the Operate/Sensor/ AspRatio menu to External.

Apply a voltage at TTL level to the Auxiliary base station connector. See Installation Manual Base Station.

Input high: aspect ratio 4:3

Input low: aspect ratio 16:9

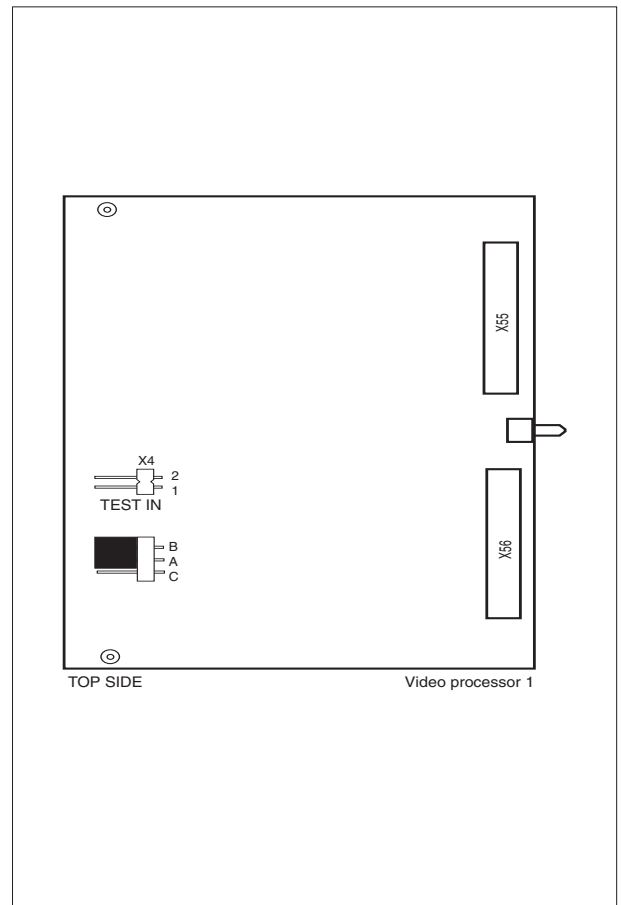

—Viewfinder Cadre Indication—

Cadre On/Off

Switch S6 on the Sync./shading board allows the cadre in the viewfinder to be switched on permanently or to be controlled by the menu system. Position AB selects (remote-) menu control (factory setting); position AC switches the cadre on permanently.

If S6 is in the remote position then you can select in Menu VF/Lens Cadre On or Off. The cadre is switched to the 4:3 format or to the 16:9 format depending on the position of the aspect ratio switch.

Cadre appearance

Switch S7 on the Sync./shading board allows the cadre in the viewfinder to take the form of two dotted lines or two low-contrast areas outside the picture area. Position AB selects the dotted lines; position AC selects the low-contrast areas.

The contrast of the cadre strips is adjusted with potentiometer ZR247 on the Video/Miscellaneous board.

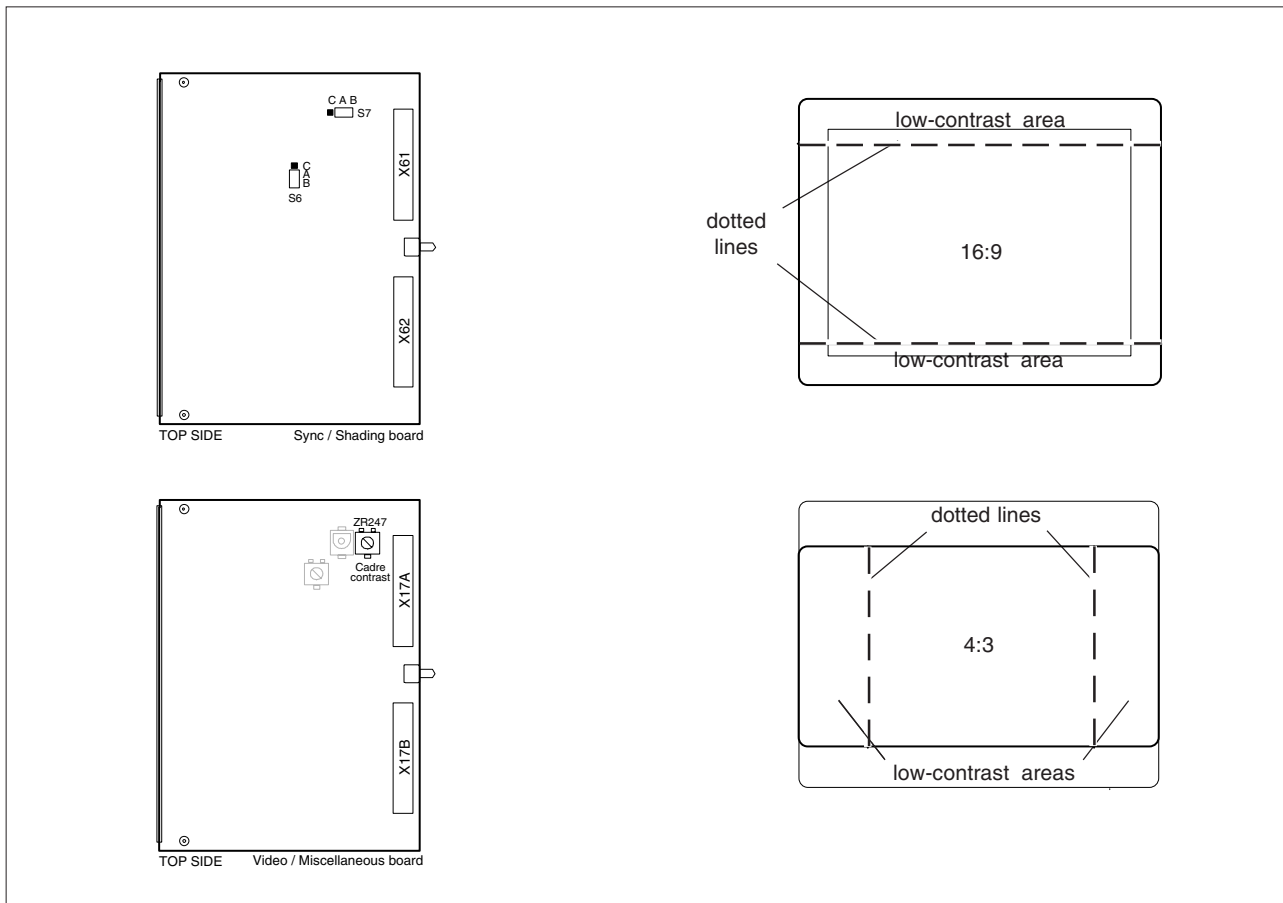

Audio / Intercom settings

Audio microphone signals

The high-pass filters in the audio channels reduce the background noise in the audio microphone signals.

The high-pass filters can be set as follows:

Audio 1 at MCP on/off (off=default setting)
 Audio 2 at MCP on/off (off=default setting)

The phantom power for different types of microphones can be set as follows:

Audio 1	S100:	D1-E1/D2-E2	+12Vdc
		B1-C1/B2-C2	Ground *
		A1-B1/A2-B2	+48Vdc
Audio 2	S200:	D1-E1/D2-E2	+12Vdc
		B1-C1/B2-C2	Ground *
		A1-B1/A2-B2	+48Vdc

(* factory setting)

Intercom headset signals

The signal to the headset of the tracker can be selected by S420 on the Audio/Intercom LF board. Position AB (the factory setting) selects the tracker microphone sidetone signal; position AC selects the ENG signal.

Intercom microphone signals

The gain of the cameraman microphone signal can be set at Camera Menu as follows:

40db (default setting) 0db

The gain of the tracker microphone signal can be set at Camera Menu as follows:

40db (default setting) 0db

The factory settings are for headsets with a dynamic microphone.

The phantom power for both cameraman and tracker microphones can be set with S300 as follows:

AC	+12Vdc
AB	Ground (factory setting)

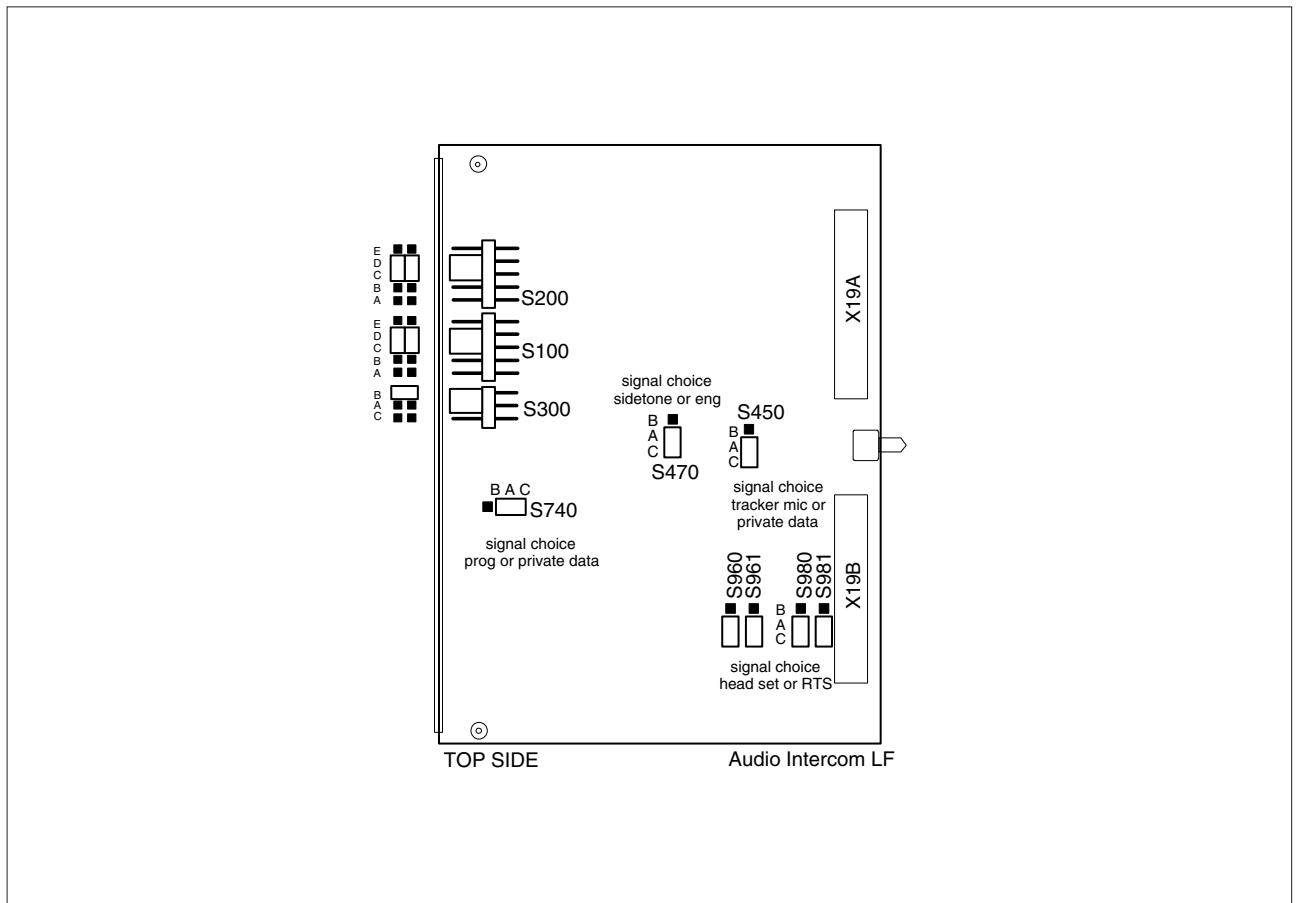

Private Data

Private data channels can be used for the transmission of serial data via the triax cable. For example, electronic scriptboard or character data for a video display unit can be transmitted to the camera.

The tracker microphone intercom channel is used for the data channel from camera head to base station. The program intercom channel is used for the data channel from base station to camera head. The input and output signals are available on the auxiliary connectors of the camera and base station (for camera see the connectors and cables section). If a channel is used for private data, then of course the original functions are no longer available.

To select the function of the base station to camera channel use S801 on the Audio/intercom board. Position AB selects the Progr function (factory setting); position AC selects the private data function.

To select the function of the camera to base station channel use S802 on the Audio/intercom board. Position AB selects the tracker microphone function (factory setting); position AC selects the private data function.

Remember that the propagation-delay times are different for different triax cable lengths, especially if a return signal is involved. At maximum lengths of 2400 metres the total delay is at least 25 μ sec. and can be more than 30 μ sec, depending on the type of triax cable.

Data signal specifications:

Baudrate: 2400
 Input level: TLL, possible RS232
 Input impedance: 100Kohm
 Output impedance: ~300 ohm
 Max load: ~1Kohm

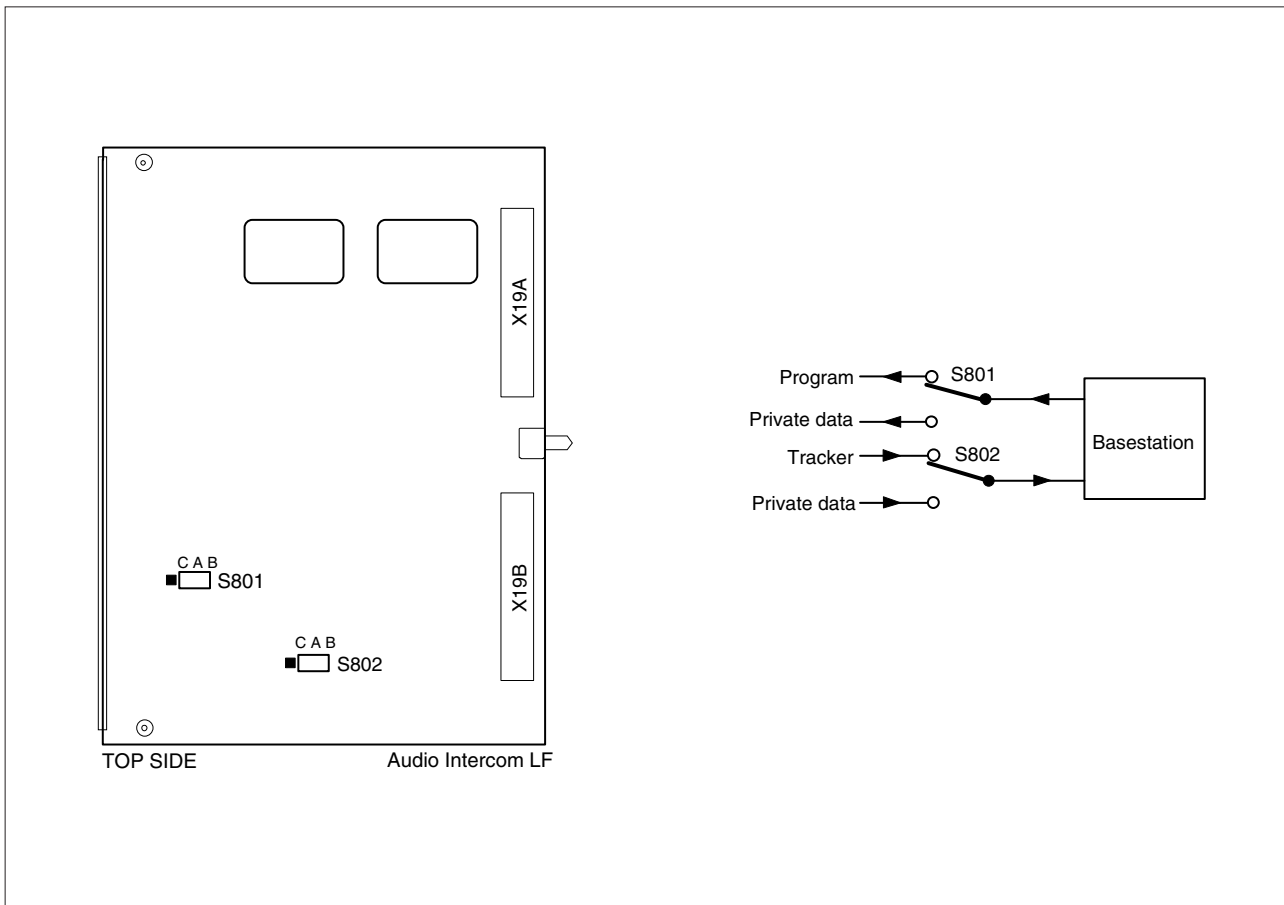

Connectors and Cables

VTR connector

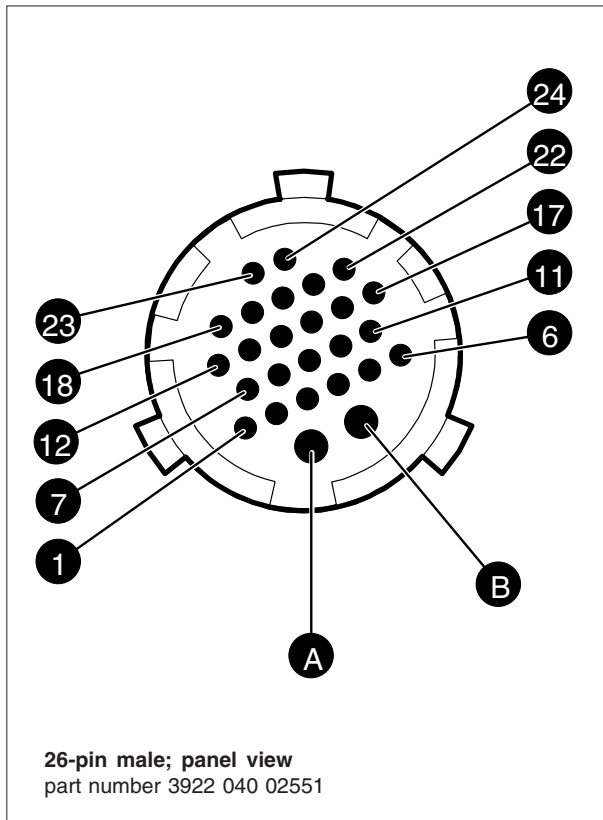

- A. + Battery from VTR (10.7 to 17V)
- B. Ground
- 1. CVBS (only available with encoder option present)
- 2. CVBS Return (only available with encoder option present)
- 3. Y + S Return
- 4. Y + S (luminance + sync.)
- 5. Pr: NTSC 700mV 75% saturated colour bar
Cr: PAL 525mV (EBU N10)
- 6. Pr/Cr Return
- 7. Pb: NTSC 700mV 75% saturated colour bar
Cb: PAL 525mV (EBU N10)
- 8. Pb/Cb Return
- 9. Not connected
- 10. Not connected
- 11. Not connected
- 12. VTR start/stop: +5V = recording; 0V = stop
- 13. Not connected
- 14. Not connected
- 15. Record/Tally
- 16. Not connected
- 17. Camera ground (shield)
- 18. Playback video input
- 19. Playback video return
- 20. Audio monitoring / VTR Save
- 21. Not connected
- 22. Not connected
- 23. Not connected
- 24. Not connected

Triax connector

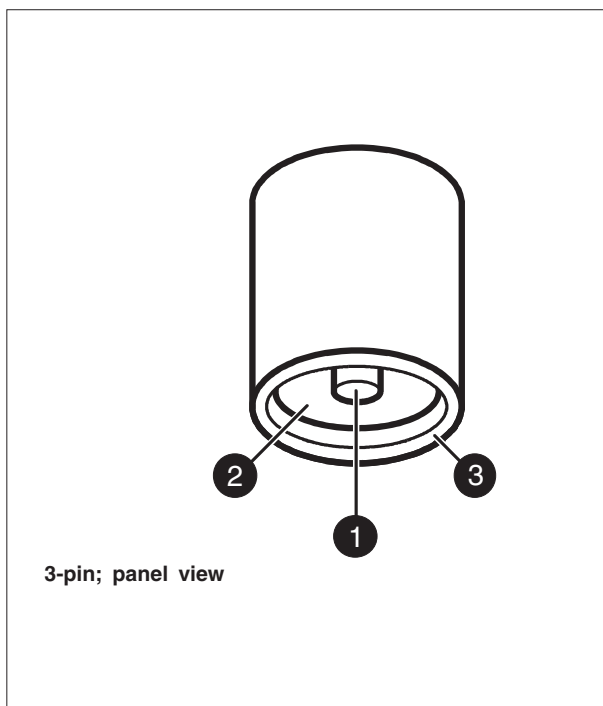

Fischer

- 1. Inner pin: Signals + power
 - 2. Inner shield: Return
 - 3. Outer shield: Camera housing
- part number 2432 020 00009

Trilock

- 1. Inner pin: Signals + power
 - 2. Inner shield: Return
 - 3. Outer shield: Camera housing
- part number 3922 040 02682

ARD

- 1. Inner pin: Signals + power
 - 2. Inner shield: Return
 - 3. Outer shield: Camera housing
- part number 3922 040 01492

LEMO

- 1. Inner pin: Signals + power
 - 2. Inner shield: Return
 - 3. Outer shield: Camera housing
- part number 3922 040 02541

Viewfinder connector

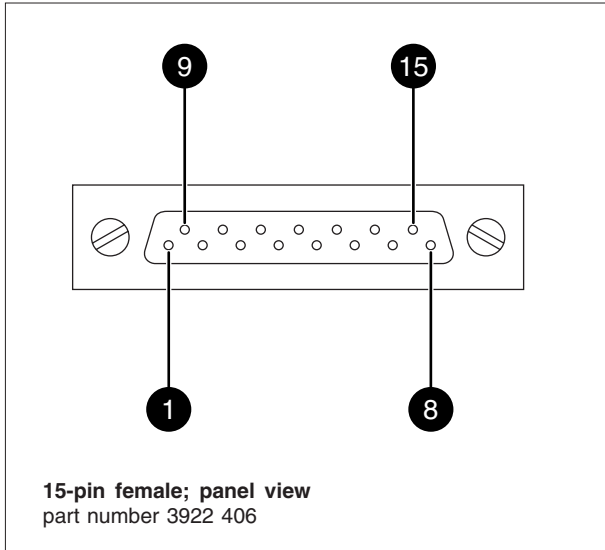

1. Video VF (Y + Sync)
2. (R-Y) Video
3. (B-Y) Video
4. Power return
5. Housing
6. +12 Vdc
7. SCL
8. INTN
9. Video VF return
10. (R-Y)/(B-Y) return
11. +12 Vdc
12. Power return
13. Housing
14. On air lamp
15. SDA

Camera headset connector

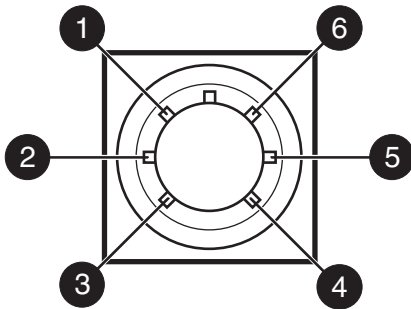

Tuchel 6-pin female; panel view
part number 2422 026 02902

1. Telephone left
2. Not connected
3. Microphone
4. Microphone return
5. Telephone right
6. Telephone return

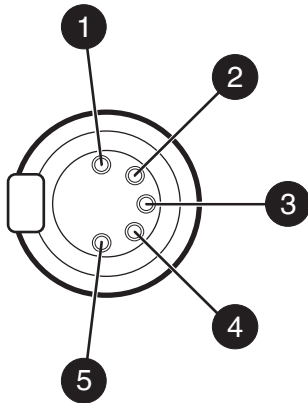

XLR 5-pin female; panel view
part number 2432 026 00176

1. Microphone return
2. Microphone
3. Telephone return
4. Telephone left
5. Telephone right

- Microphone level -58dBm/-20dBm switchable
- Microphone impedance 200 ohm
- Telephone level +6dBm nominal
- Telephone output impedance <10 ohm

Audio microphone connectors

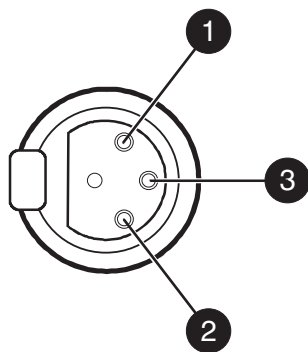

XLR 3-pin female; panel view
part number 2422 026 02984

1. Audio Screen
2. Audio In
3. Audio Return

- Microphone impedance > 200 ohm
- Sensitivity remote controlled via base station:
range: -70 to -28 dBm
maximum input = -6 dBm
- Signal at pin 2 of audio input is in phase with
signal at pin 2 of audio output on Base Station

Auxiliary connector

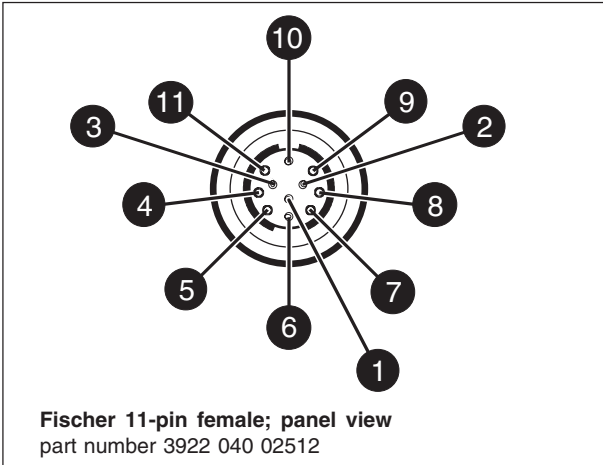

1. +5VL
2. 0VL
3. AN0
4. AN1
5. Spare
6. Not connected
7. Private Data Camera - Base Station
8. Ground
9. Private Data Base Station - Camera
10. Ground
11. Shield

Tracker communication connector

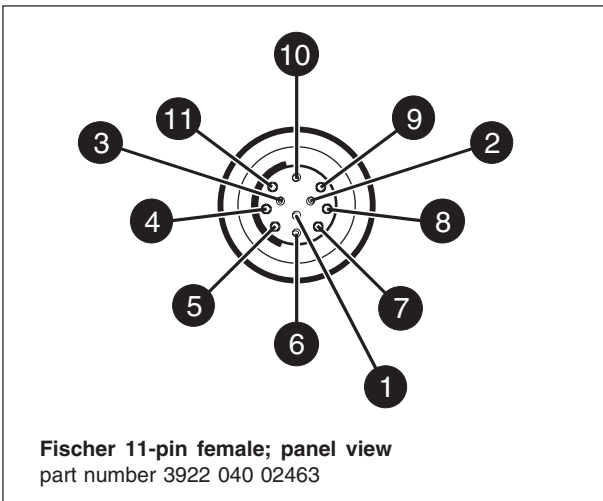

1. On-air signal return
 2. Tracker microphone return
 3. Tracker microphone input
 4. Production tracker
 5. Sidetone tracker
 6. Return
 7. Program tracker
 8. Cameraman microphone
 9. Tally control tracker (Cmos level, R out = 1k)
 10. +12V; I max. = 100mA
 11. +12V return
- Microphone level -58dBu/-20dBu switchable
 - Microphone impedance 200 ohm
 - Telephone level + 6dBu
 - Telephone output impedance <10 ohm

Data connector

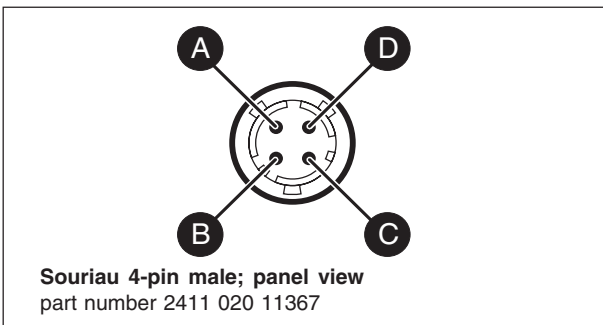

- A. Data
- B. Data not
- C. Not Connected
- D. Shield

Script light connector

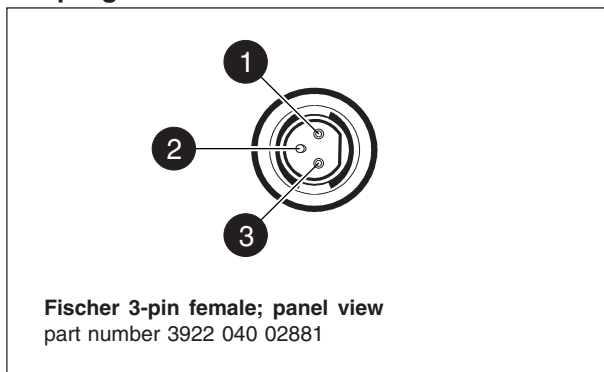

1. +12V (Maximum Dissipation 3W)
2. Power Return
3. Shield

Cable connector part numbers

Panel Connector	Type	Part number	Cable part number
VTR	26-pin male	3922 040 02551	VTR cable LDL 2110/ *
Triax	3-pin Fischer female	2432 020 00009	LDK 8200/ **
Triax	3-pin Trilock	3922 040 02682	--
Triax	3-pin ARD	3922 040 01492	--
Triax	3-pin Lemo	3922 040 02541	--
Viewfinder	15-pin Female	3922 406	--
Headset	6-pin Tuchel female	2422 026 02902	--
Headset	5-pin XLR female	2432 026 00176	--
Audio Mic	3-pin XLR female	2422 026 02984	--
Auxiliary	11-pin Fischer female (two slot)	3922 040 02512	2432 026 00254 male
Tracker	11-pin Fischer female (one slot)	3922 040 02463	2432 026 00252 male
Data	4-pin Souriau male	2411 020 11367	2411 020 12025 female
Script Light	3-pin Fischer female	3922 040 02881	2432 026 00253 male
Ext video/Tp	2-pin Coax female	2422 031 10529	--

* /02 is 2 m
/05 is 5 m
/10 is 10 m

** /00 for 8 mm cable
/10 for 11 mm cable
/20 for 14 mm cable

Specifications LDK20

Camera system

Transmission system
NTSC/PAL

Pick-up device
3 x 2/3-inch Thomson DPM Frame Transfer CCDs

Smear performance
No vertical smear

Aspect ratio
4:3/ 16:9 switchable

Picture elements
4:3 and 16:9 aspect ratio
NTSC: 1000(h) x 498(v)
PAL: 1000(h) x 594(v)

Optical system
F1.4 with quartz filter

Filter cassette with Optical filters
Exchangeable filter cassette with remote selectable 6 positions: Clear; ND 0.6; ND 1.2; ND 1.8; 4-point star; 6-point star

Video performance

Video processing
Hires Digital Processing with 12 bit A/D and 14 bit DSP technology

Digital features
Flare; White shading; Contrast; Highlight Handling; 6 point var. Matrix; Matrix-pos.; Gamma; Gamma Curve; Contour include Skin detail and Extended Contour Gamma;

Leaking Pixel Corr.; VF video

Sensitivity
2000 lux (186 ft cd) at F8.0
Condition: 3200K, reflectance 89.9%, 0 dB gain

Minimum illumination
Approx. 2 lux at F 1.4 and +30 dB gain

S/N ratio at normal gain
Typical: 61 dB PAL and 63 dB NTSC
Remark: +6dB S/N improvement with High Resolution Digital Noise Slicer

Modulation depth
>70% at 5Mhz in RGB Centre equivalent 800 TV lines
Remark: >65% at 5Mhz in RGB Centre with High Resolution Digital Noise Slicer

Registration
<25 ns (0.05%) in all three zones, normal operation and not including lens errors

Exposure control
Down to 1/1000s

Lighting control
NTSC: nominal, 60 Hz +/- 4 Hz
PAL: nominal, 50 Hz +/- 3 Hz

Clean scanning
NTSC: between 61.1 and 151.0 Hz
PAL: between 51.0 and 103.0 Hz

General data

Concept
Studio configuration with PIP on 7-inch VF

Triax cable length
2,400m (7,875 ft) max. with 16mm (0.63") cable
Options for Long Triax available

Head weight (approx.)
26 kg (57.4 lb) excl. 7-inch VF

Head dimensions (lhxwx) in mm (inches) - approx.
367 x 305 x 240 (14.4 x 12 x 9.4)

Ergonomics
Moving VF position for easy camera fixing

Operating ambient temperatures
-20 to +45°C (-4 to +113°F) for Camera Head
0 to +45°C (32 to +113°F) for all other items

Stand alone power required
Utility power 115/230V ac +/- 15%
Nominal 70VA
Max. 200VA (cable/system dep.)
50 W

Power consumption
(Head + VF) 220W incl. Camera Head, VF,
Power consumption
(Average system) 70VA Utility; 700m (2.297ft)
Triax cable and lens

Audio performance

Audio channels 2 channels
Microphone power Selectable 0/+12V/+48V
Input levels at Camera Head -64 dB/ -24 dB/0 dB
Output levels at Base Station 0/+6 dB

Intercom performance

Intercom Headsets on Head Cam.Man
Intercom Channels ENG/PROD/PROG
Input levels at Camera Head -64 dB/-24 dB
Output levels at Base Station 0/+6 dB

Connectors Camera Head

Triax Option: Fischer/ARD/Lemo/
Trilock

Power AC-power connector
Lens 36p
Viewfinder 15p D
Mic In (Audio) 2 x XLR3
Cameraman headset Option: XLR5/Tuchel
Video out Option: 1 Vpp; 75 Ohm; BNC
Genlock in 1 Vpp; 75 Ohm; BNC
VF-out 1 Vpp; 75 Ohm; BNC
TP-video out 1 Vpp; 75 Ohm; BNC
External Camera Control 4p DATA
VTR 26p SMPTE
Scriptlight power 3p; 12V
AUX 11p; private data
Tracker 11p; Communication/Signalling

Connectors Base Station

Triax Option: Fischer/ARD/Lemo/
Trilock

Power AC-power connector
Audio out 2x XLR3
Intercom ENG/PROD/PROG
via 15p D-connector
Signalling Call/Tally R/Y via 15p D-conn.
CVBS (3x) 1 Vpp; 75 Ohm; BNC
RGB 700 mVpp; 75 Ohm; BNC
Y, R-Y, B-Y 700, 525, 525 mVpp; 75 Ohm;
BNC
PXM 1 Vpp; 75 Ohm; BNC
WFM 1 Vpp; 75 Ohm; BNC
Serial Digital (2x) 270 MB/s Option: 800 mV; 75 Ohm; BNC
Ext 1, 2 1 Vpp; 75 Ohm; BNC
Genlock in 1 Vpp; 75 Ohm; BNC
TP-video input 1 Vpp; 75 Ohm; BNC
Ext. Camera Control 4p DATA

Viewfinder

Type 7-inch B/W
Features Picture in Picture; Crosshairs;
Cursorbox
Resolution > 700 TVL
Weight 7 kg (15.4 lb)
Power 30 W

These typical specifications are valid for PAL and NTSC systems and are subject to change without notice

Section 3

Replacements

This section gives information on the procedures to follow when replacing printed circuit boards and mechanical components at first line level.

Contents

Introduction	3-2	Filterwheel Cassette	3-4
Printed circuit boards	3-2	Power supply	3-4
Front module	3-3		

The instructions given in this section are restricted to those modules which can be replaced at the first line level. After a printed circuit board has been replaced it is sometimes necessary to carry out adjustments to match the new boards to your camera and so maintain the performance levels. The relevant adjustment procedures are referenced in section 4. The procedures for removing the modules should be followed in reverse order when remounting the units.

- To remove a printed circuit board proceed as follows:
- Open the side cover (see section 2).
 - Swing the black cover **1** of the printed circuit board open.
 - Pull horizontally on this cover to free the board from its connector and slide it clear of the camera.

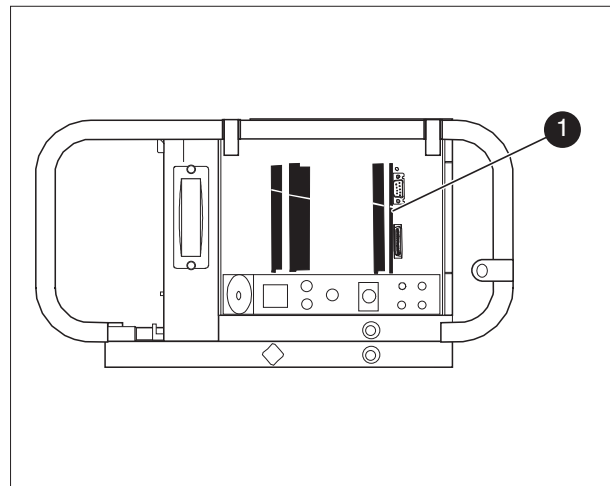

Front module

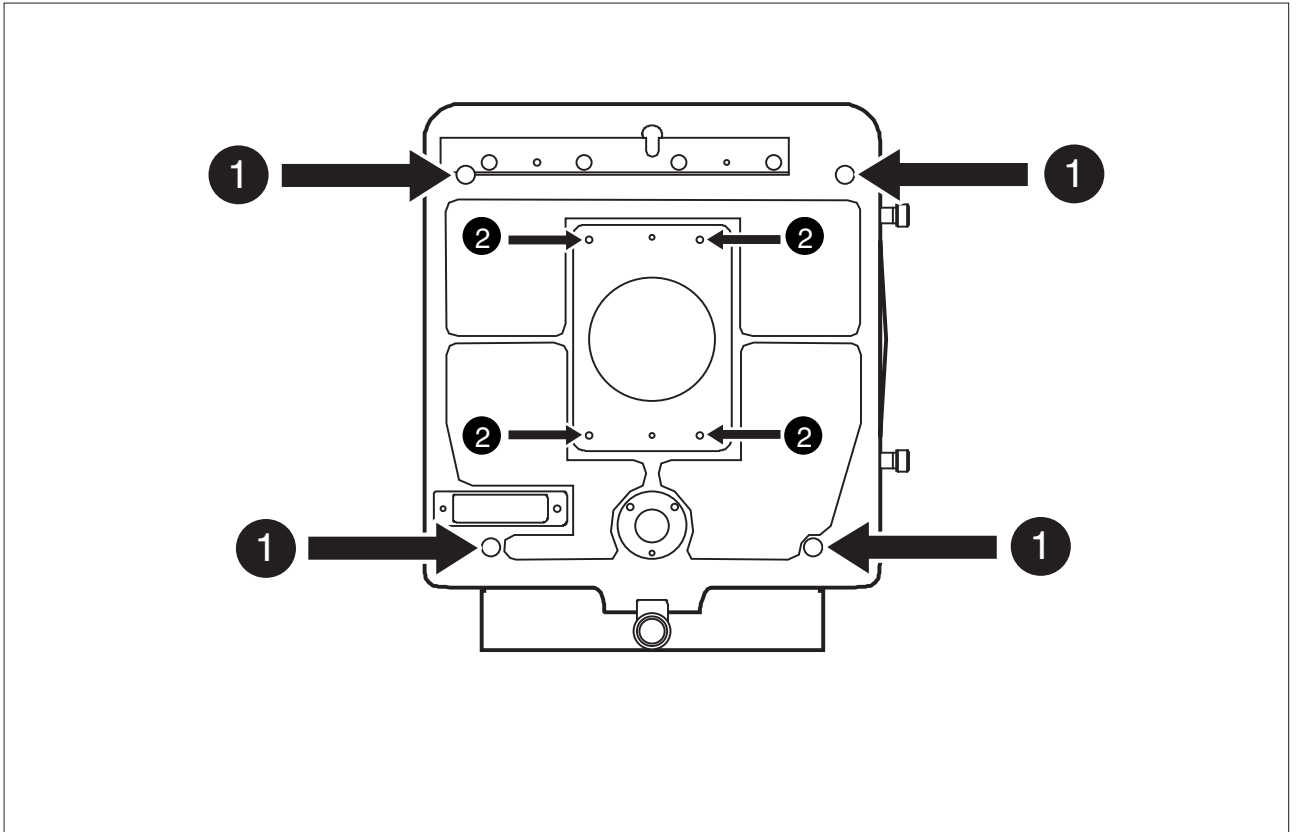

To remove the front module proceed as follows:

- On the frontside of the camera remove the four screws **1** securing the front assembly.
- Remove the front assembly from the camera.
- Remove the Front Interconnection Board by unscrewing two screws from the backside of the front module.
- Loosen the four screws **2** securing the front module.
- Slide the front module straight out of the front assembly.

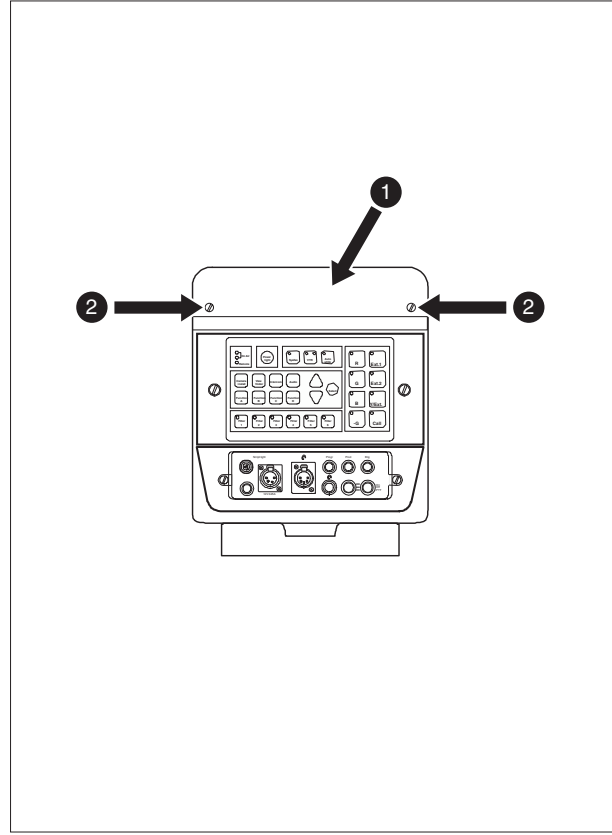
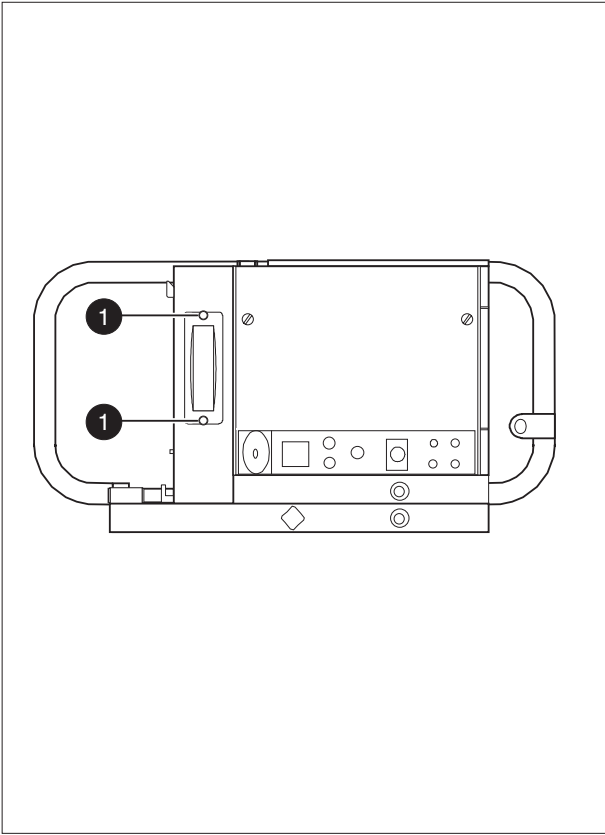

To remove the filterwheel cassette proceed as follows:

- a. Loosen the two screws **1** securing the cover to the body of the front assembly.
- b. Loosen the two screws securing the cassette to the body of the front module.
- c. Use the grip to pull the cassette horizontally out of the camera.

Before removing the power unit **1** unscrew the two screws **2** on the top of the camera which secure the power unit to the camera.

To replace the filterwheel cassette proceed as follows:

- a. Push the cassette horizontally into the camera.
- b. Tighten the two screws to secure the cassette to the body of the front module.
- c. Replace the cover and tighten the two screws **1**.

Section 4

Adjustments

This section contains the adjustment procedures to be followed to obtain the best performance from the camera. These procedures need only be used if, following a module replacement, the camera does not perform according to specifications.

Contents

Introduction	4-2	Digital Video Processor	4-15
Test Equipment	4-3	Video Miscellaneous Board	4-17
Set-up Instructions	4-3	Sync./Shading Board	4-27
Video Processor 1 Board	4-5	Video Miscellaneous Board	4-35
Digital Video Processor	4-10	Encoder Board PAL	4-37
Digital Video Processor	4-11	Encoder Board NTSC	4-43
Digital Video Processor Subboard	4-12	Audio/Intercom LF Board	4-51
Digital Video Processor Subboard	4-13	Audio/Intercom LF Board RTS MODE	4-55
Digital Video Processor	4-14	Pre-Processor Board	4-57

Introduction

This camera is factory tested and adjusted for operational use. Under normal circumstances, the internal potentiometers do not need to be adjusted.

If it is discovered that the camera is misaligned, the following procedures are given as a guide for competent service personnel, who have a thorough knowledge of the camera and have the use of calibrated equipment, to realign the camera.

If no improvement can be achieved or an adjustment is out of range, please contact your local supplier or the nearest Thomson Multimedia Broadcast Solutions Service Centre.

The camera head adjustment procedures are designed as separate units. Within a numbered procedure do not change the position of switches or jumpers unless instructed to do so in the procedure.

These adjustment procedures are for the Camera Head. The adjustments require the use of a **Master Control Panel** in combination with an **Operational Control Panel** if possible. The intercom adjustments are given for a four-wire system.

The following is a list of equipment required to carry out the adjustment procedure:

- Set of board extenders LDK 4830/21
- Oscilloscope (with cursor measurement)
- Spotlight 3200K
- Gamma Test chart 4:3 / 16:9
- Waveform monitor
- Colour monitor
- Multimeter
- Master Control Panel LDK 4607 / LDK 4609
- Operational Control Panel LDK 4624 / LDK 4628 / LDK 4629
- Audio Analyser
- Base Station LDK 4053

Before carrying out any adjustments the following steps are recommended:

- Install the camera on a tripod.
- Attach the lens and the necessary cables.
- Allow the camera to warm-up.
- Operate the camera in stand-alone mode
- Connect an MCP and OCP to the data connector on the right connector panel of the camera.
- When the camera is used in the stand-alone mode, MCP and OCP always operate in camera select position 1 (OCP camera select switch in position 1).

CAUTION:

Do not attempt to improve camera performance by adjusting individual potentiometers, jumpers or switches as this may lead to complete misalignment of the camera.

CAUTION:

Do not realign individual potentiometers, jumpers or switches not mentioned in this chapter or earlier in this manual. These adjustment points are for factory use only.

CAUTION:

Switch off the power supply to the camera before removing or replacing printed circuit boards.

—Video Processor 1 Board—

Setting-up the Camera

Note:

Video Processor 1 must be adjusted in combination with the Sync./Shading board.

1. For local powering of the camera in the stand-alone mode (see User Guide, Section 4).

2. Recall Factory Standard File on MCP or OCP.

On MCP set:

OPERATE MENU

Knee	:	Off
Contour	:	Off
Gamma	:	Lin.
Blk. Str.	:	Off
Auto Iris	:	Off

SETUP 1 MENU

Studio mode:	:	Off
Flare	:	Off
White clip	:	Off

SETUP 2 MENU

Soft cont.	:	Off
------------	---	-----

SETUP 3 MENU

Skin cont.	:	Off
------------	---	-----

SETUP 4 MENU

Notch	:	Off
Chroma	:	Off
Asp. Ratio	:	4:3

SETUP 5 MENU

Matrix sel.	:	1:1
-------------	---	-----

MAINT. 1 MENU

Wh. shading:	:	Off
--------------	---	-----

Oscilloscope: 10mV/div. probe 10:1

3. Put Video Processor 1 on a service extender.
4. Remove jumpers 7, 9, 11, 13, 17 and 19 from connector B of the service extender to interrupt the input from the front and jumpers 6, 12 and 15 to interrupt the black shading correction.
5. Short circuit the input to video processor 1 by connecting the following jumpers on connector B of the service extender:
 - B7 to B9
 - B11 to B13
 - B17 to B19

Video Processor 1 Board

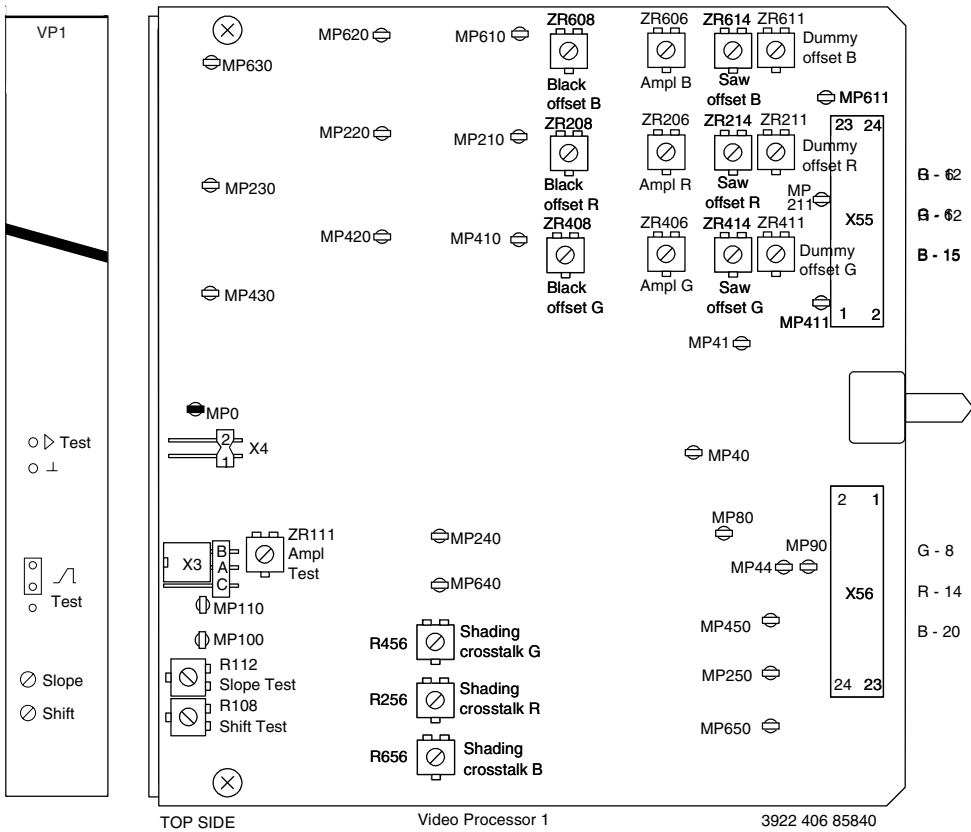

Sync./Shading Board

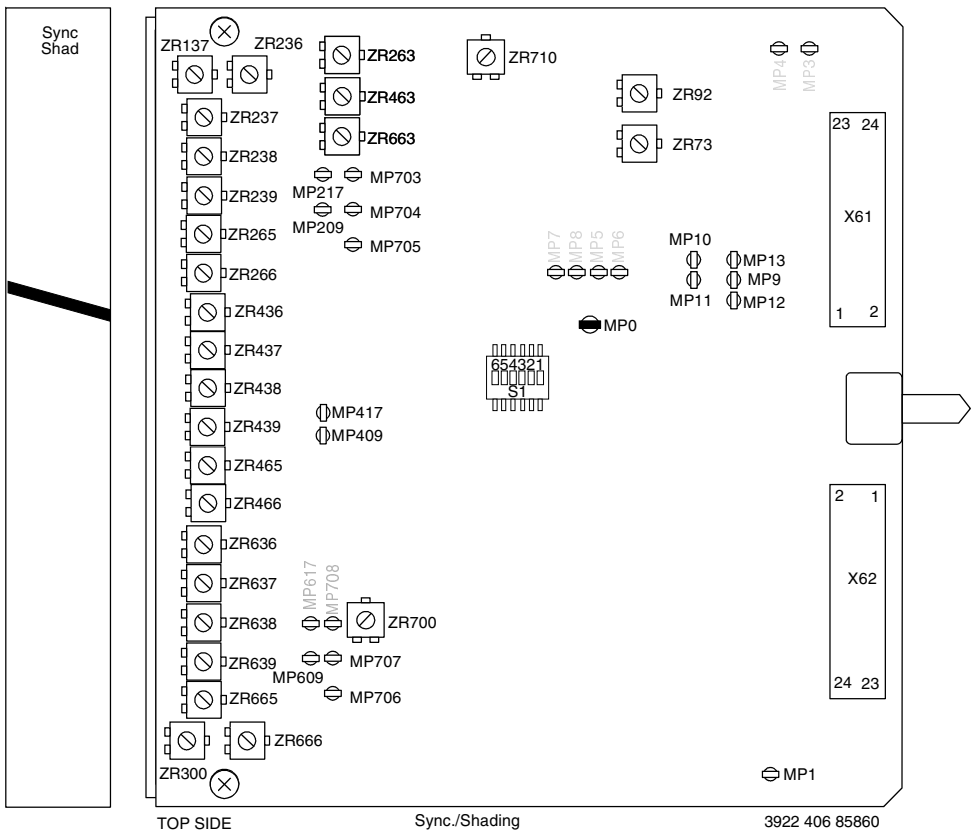

Video Processor 1 Board

Black Offset

6. In the Install/Gain menu set the gain for + to 12dB and for ++ to 30dB (the standard values are 6dB and 12dB).
7. While switching between 0dB gain and 30dB gain, adjust black level during the active line to the same as the clamp level.

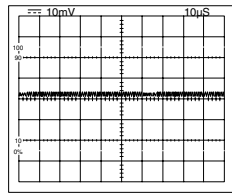
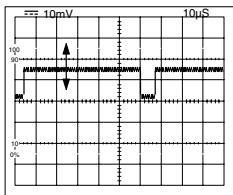
Measure at:	Adjust with:	Required result:	Correct:	Incorrect:
X56-14(R) X56-8(G) X56-20(B)	ZR208 (R) ZR408 (G) ZR608 (B)	0mV (R) 0mV (G) 0mV (B)		

Note:

When the standard file is recalled the black levels are set as follows: Master=50, R=50, G=50, B=50.

Vertical sawtooth offset

8. Adjust for no sawtooth information.

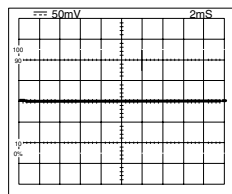
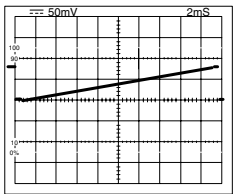
Measure at:	Adjust with:	Required result:	Correct:	Incorrect:
MP211 MP411 MP611	ZR214 ZR414 ZR614			

9. In the Install/Gain menu reset the gain for + to 6dB and for ++ to 12dB.
10. On service extender, **return jumpers 6, 12 and 15 to their positions.**

Horizontal Sawtooth

11. Place Sync./Shading board on extender and minimise the horizontal spike information.

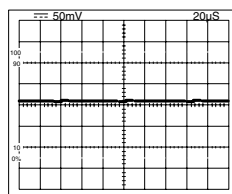
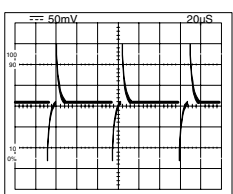
Measure at:	Adjust with:	Required result:	Correct:	Incorrect:
VP1 X55-12 (R) X55-6 (G) X55-15 (B)	Sync/Shad. ZR263 (R) ZR463 (G) ZR663 (B)	No spike No spike No spike		

12. Remove Sync./Shading board from service extender and return it to its position in the camera.

Video Processor 1 Board

Test Sawtooth Nominal Settings

15. Sawtooth amplitude

Measure at:	Adjust with:	Required result:	Correct:
MP110	ZR111	-1000mV	

16. Sawtooth slope

Set sawtooth amplitude to 100% on oscilloscope, measure between 10% and 90% and adjust slope test.

Measure at:	Adjust with:	Required result:	Correct:
MP110	R112	25 µS	

17. Sawtooth horizontal shift

Set master black level to +10%.

Adjust start sawtooth for 4.5 µS after system blanking.

Measure at:	Adjust with:	Required result:	Correct:
CVBS out	R108		

Video output

18. Adjust the video output amplitude

Measure at:	Adjust with:	Required result:	Correct:
X56-14 (R)	ZR206 (R)	450mV (R)	
X56-8 (G)	ZR406 (G)	450mV (G)	
X56-20 (B)	ZR606 (B)	450mV (B)	

Digital Video Processor

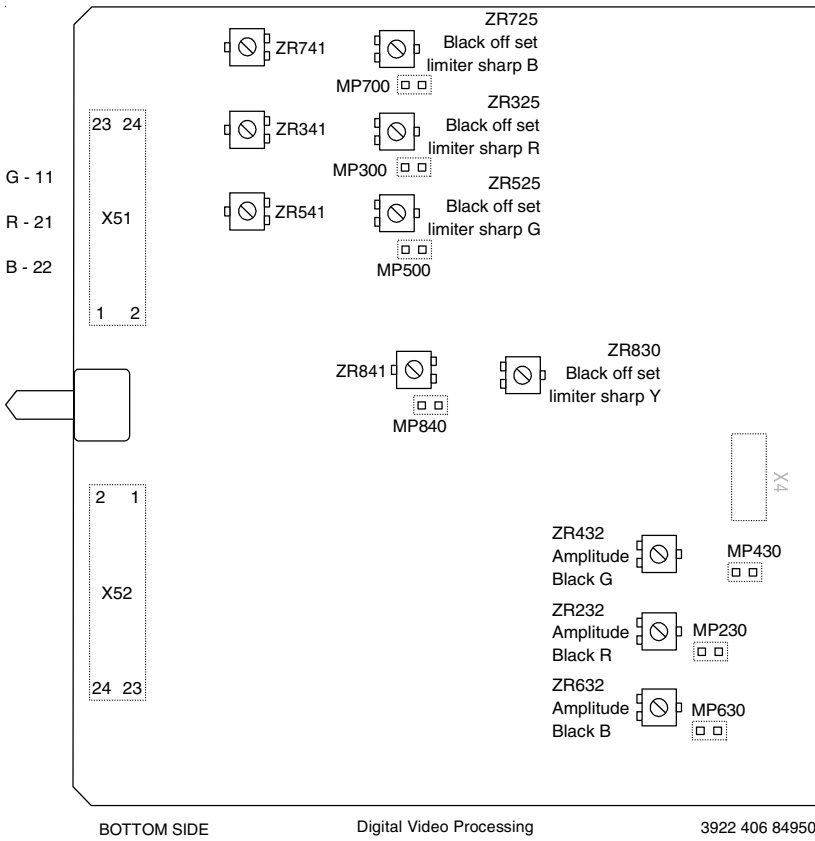

Digital Video Processor

1. Place Digital Video Processor on service extender. Set master black level to 50. Check that individual R, G and B black levels are set to 50. Switch off test sawtooth.

Black Offset Level

2. Switch on colour bar.
3. Adjust black offset during the active line to the same as the clamp level.

Measure at:	Adjust with:	Required result:	Correct:
X51-21 (R)	ZR325 (R)	0mV (R)	

Measure at:	Adjust with:	Required result:	Correct:
X51-11 (G)	ZR525 (G)	0mV (G)	

Measure at:	Adjust with:	Required result:	Correct:
X51-22 (B)	ZR725 (B)	0mV (B)	

Digital Video Processor Subboard

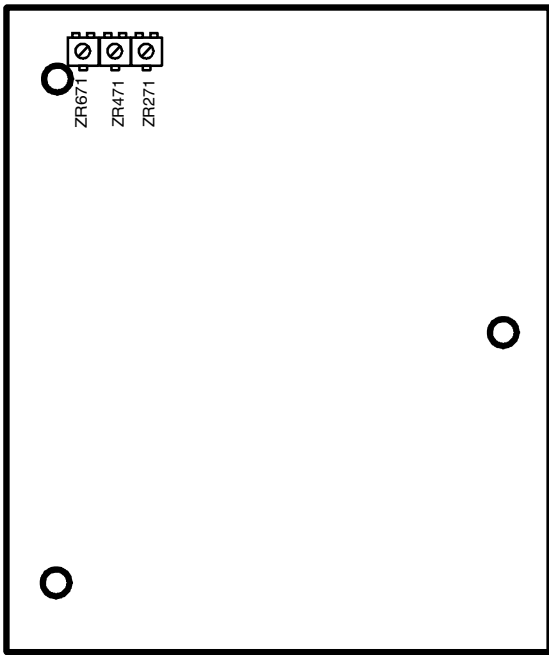

BOTTOM SIDE Subboard DSP 3922 406 84960

Digital Video Processor

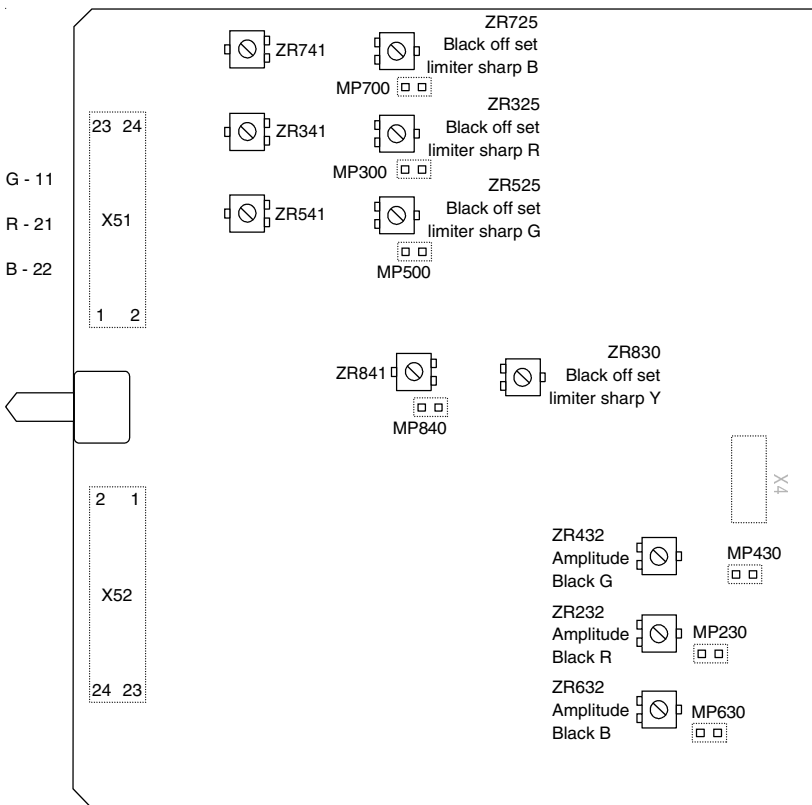

BOTTOM SIDE Digital Video Processing 3922 406 84950

Digital Video Processor Subboard

Gain DAC.

1. Adjust bar output amplitude.

PAL

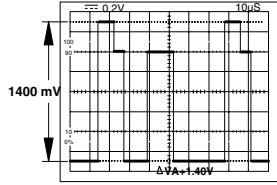
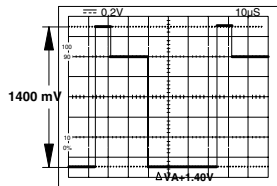
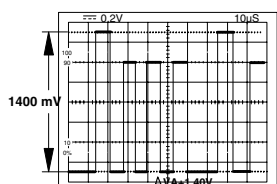
Measure at:	Adjust with:	Required result:	Correct:
X51-21	ZR271 (R)	+1400mV (R)	
X51-11	ZR471 (G)	+1400mV (G)	
X51-22	R671 (B)	+1400mV (B)	

NTSC

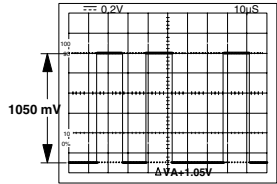
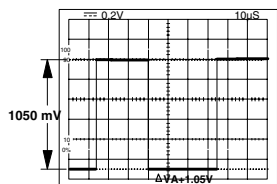
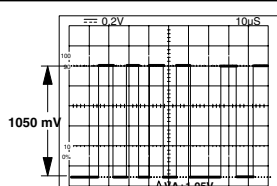
Measure at:	Adjust with:	Required result:	Correct:
X51-21	ZR271 (R)	+1050mV (R)	
X51-11	ZR471 (G)	+1050mV (G)	
X51-22	R671 (B)	+1050mV (B)	

Digital Video Processor

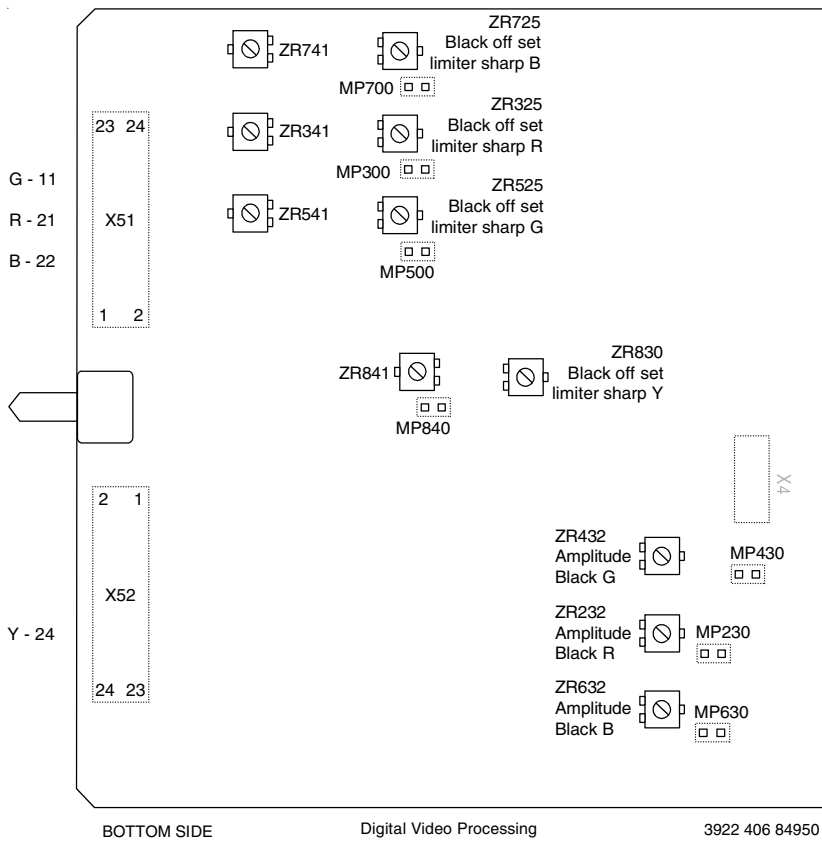

Digital Video Processor

Gain Video

1. Place Digital Video Processor on service extender.
2. Switch off colour bar and Test sawtooth on.
3. Adjust white output amplitude.

Measure at:	Adjust with:	Required result:	Correct:
X51-21 (R)	ZR232 (R)	+1400mV (R)	
X51-11 (G)	ZR432 (G)	+1400mV (G)	
X51-22 (B)	ZR632 (B)	+1400mV (B)	

White limiter

4. Set gain to +6dB. In setup 1 menu set white clip on.
Set individual white limiter to: Master G = 60, R = 60, B = 60.
5. Adjust output for a video clip level of 102%.

Measure at:	Adjust with:	Required result:	Correct:
X51-21 (R)	ZR341 (R)	+1428mV (R)	
X51-11 (G)	ZR541 (G)	+1428mV (G)	
X51-22 (B)	ZR741 (B)	+1428mV (B)	

Output amplitude readjustment

6. Set gain to 0dB. In setup 1 menu set white clip off.
7. Readjust white output amplitude.

Measure at:	Adjust with:	Required result:	Correct:
X51-21 (R)	ZR232 (R)	+1400mV (R)	
X51-11 (G)	ZR432 (G)	+1400mV (G)	
X51-22 (B)	ZR632 (B)	+1400mV (B)	

VF-Mon output

8. Test sawtooth on.
9. Adjust Y-output amplitude.
10. Adjust output dc level

Measure at:	Adjust with:	Required result:	Correct:
X52-24	ZR841	+1400mV	
	ZR830	0mVdc	

11. Return Digital Video Processor to its position in the camera.

Video Miscellaneous Board

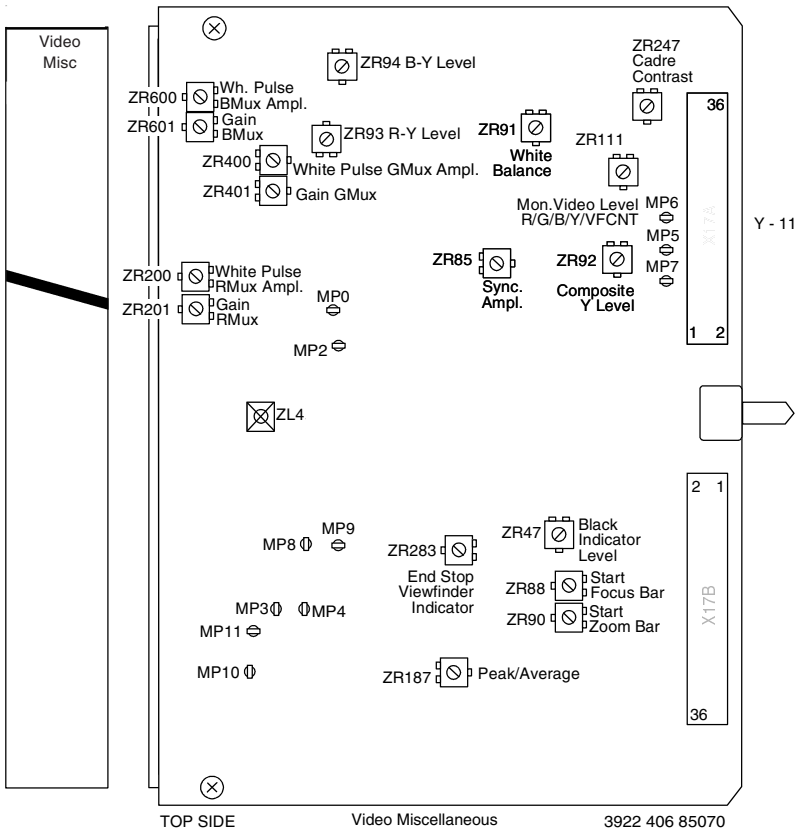

Video Miscellaneous Board

- Place Video Miscellaneous Board on service extender.

VF sync. oscillator

- Test sawtooth off.
- Adjust VF sync. frequency.

Measure at:	Adjust with:	Required result:	
MP2	ZL4	+2.5V DC level	

Output amplitude

- Test sawtooth on.
- Adjust Y output amplitude.

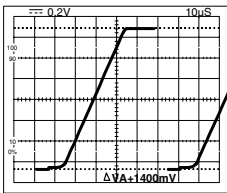
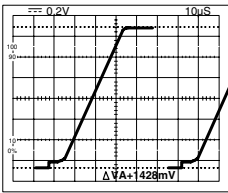
Measure at:	Adjust with:	Required result:	PAL	NTSC
X17A-11	ZR92	+1400mV PAL +1428mV NTSC		

- Adjust Y sync. output amplitude.

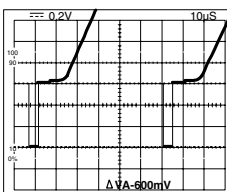
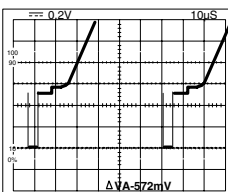
Measure at:	Adjust with:	Required result:	PAL	NTSC
X17A-11	ZR85	-600mV PAL -572mV NTSC		

R-Y / B-Y white balance

- Test sawtooth off
- Colour bar on.
- Connect oscilloscope, via a vectorscope terminated with 75 Ohm, to the CVBS output of the camera and adjust for a minimum unbalance in white.

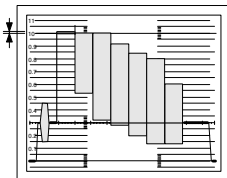
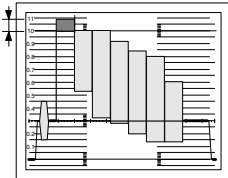
Measure at:	Adjust with:	Required result:	Correct:	Incorrect:
CVBS out	ZR91			

Video Miscellaneous Board

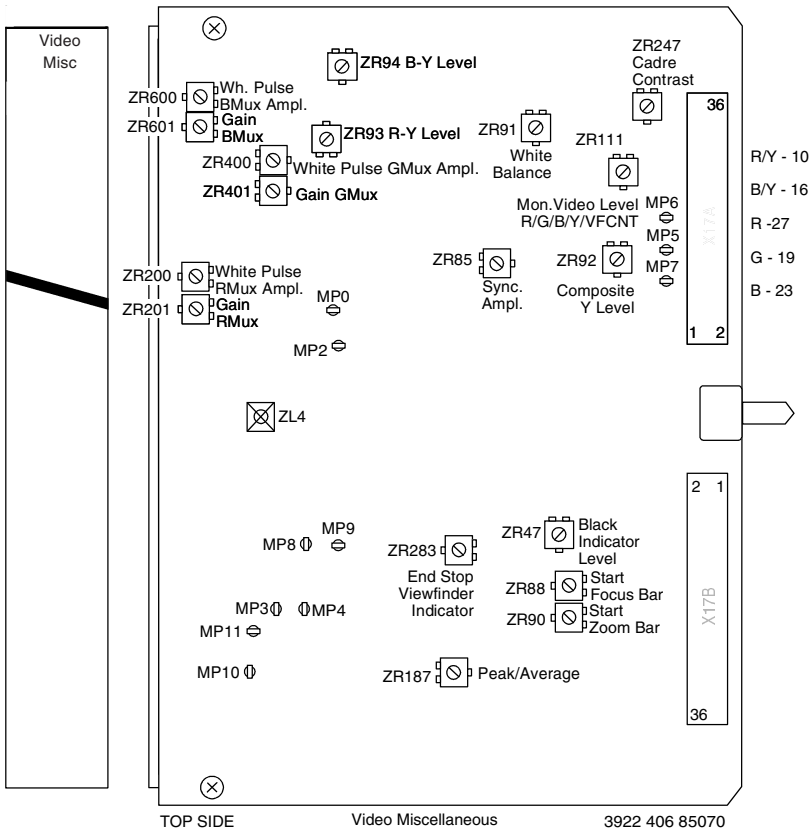

Video Miscellaneous Board

R-Y amplitude

10. Adjust R-Y output amplitude.

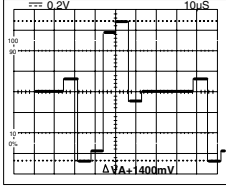
Measure at:	Adjust with:	Required result:	Correct:
X17A-10	ZR93	1400mV	

B-Y amplitude

11. Adjust B-Y output amplitude.

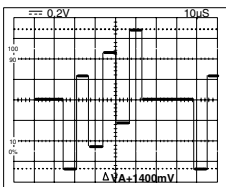
Measure at:	Adjust with:	Required result:	Correct:
X17A-16	ZR94	1400mV	

Video Mux output

12. Colour bar off.

13. Test sawtooth on.

14. Adjust R-Mux output.

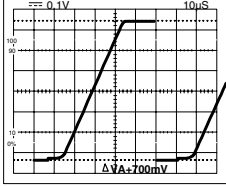
Measure at:	Adjust with:	Required result:	Correct:
X17A-27	ZR200	700mV	

15. Adjust G-Mux output.

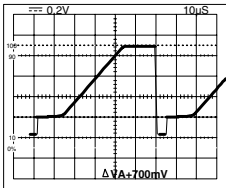
Measure at:	Adjust with:	Required result:	Correct:
X17A-19	ZR400	700mV	

16. Adjust B-Mux output.

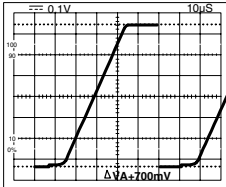
Measure at:	Adjust with:	Required result:	Correct:
X17A-23	ZR600	700mV	

Video Miscellaneous Board

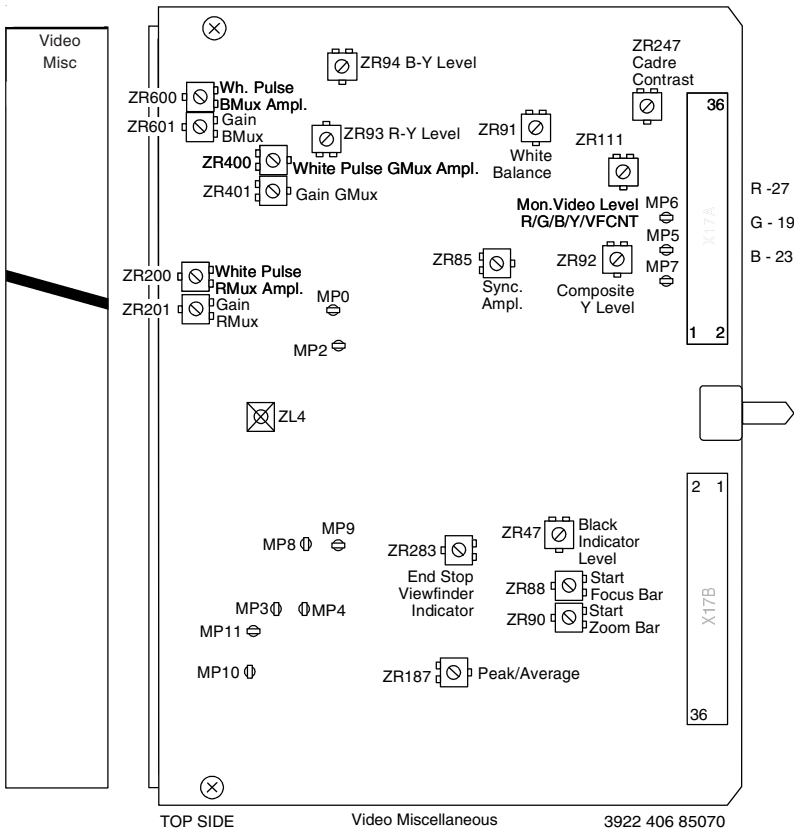

Video Miscellaneous Board

White pulse amplitude

17. Connect camera to a base station and switch to Triax mode.
18. Adjust the white pulse in line 10 (PAL), in line 13 (NTSC) for the R-Mux output.

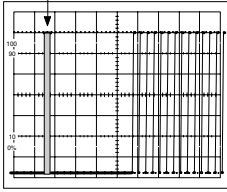
Measure at:	Adjust with:	Required result:	Correct:
X17A-27	ZR201	700mV	

19. Adjust the white pulse in line 10 (PAL), in line 13 (NTSC) for the G-Mux output.

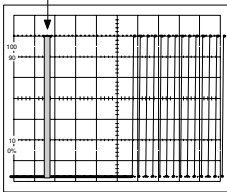
Measure at:	Adjust with:	Required result:	Correct:
X17A-19	ZR401	700mV	

20. Adjust the white pulse in line 11 (PAL), in line 14 (NTSC) for the B-Mux output.

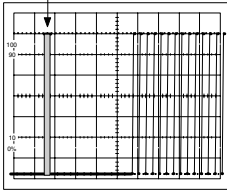
Measure at:	Adjust with:	Required result:	Correct:
X17A-23	ZR601	700mV	

21. Set up camera in the stand-alone mode again.

Monitoring camera output

22. Use the controls at the rear panel of the camera to select the Y signal for the monitoring output by navigating through the menu system.
23. Connect oscilloscope terminated with 75 Ohm to the VF output of the camera.
24. Adjust the amplitude of the VF output signal.

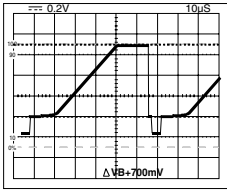
Measure at:	Adjust with:	Required result:	Correct:
VF output	ZR111	PAL 700mV NTSC 714mV (100IRE)	

Video Miscellaneous Board

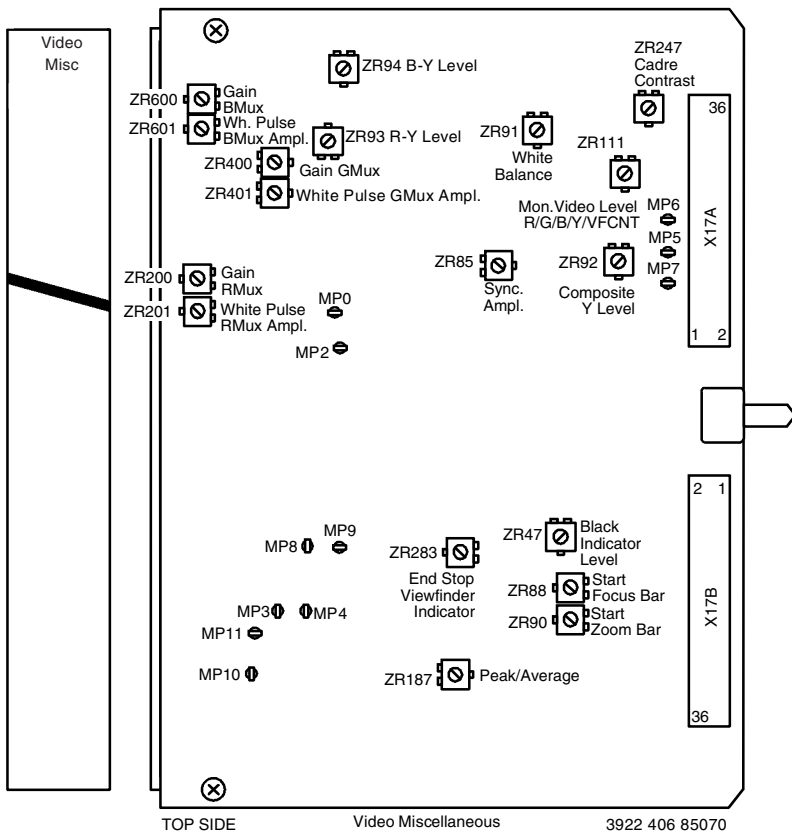

Extender Board

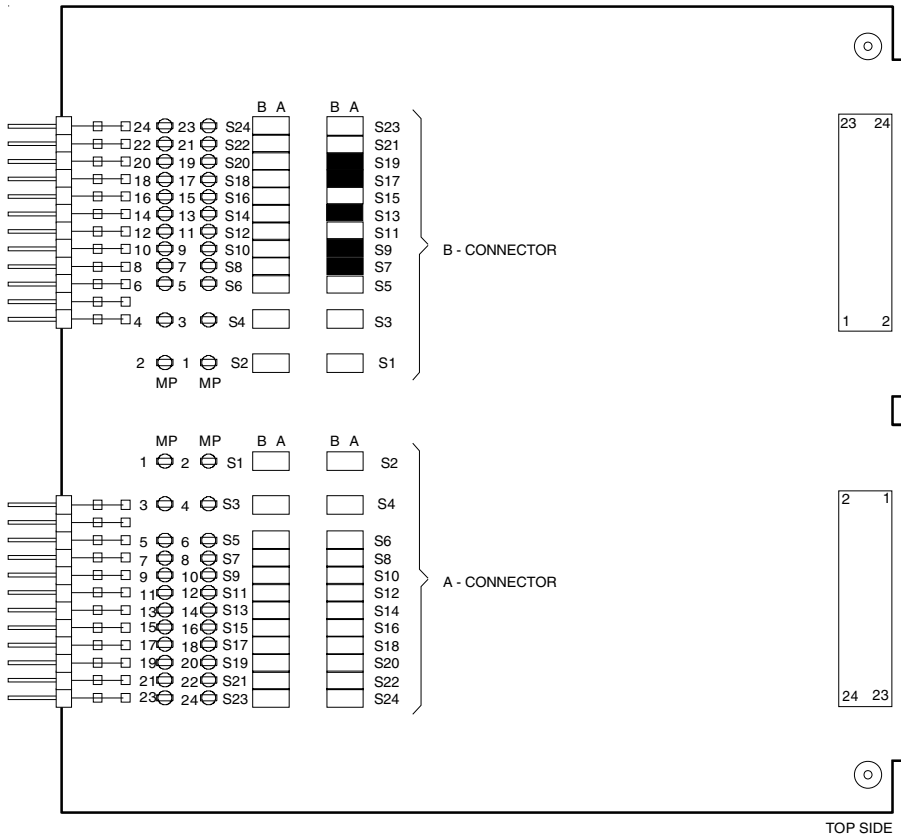

Video Miscellaneous Board

Black indicator level

25. Use the controls at the rear of the camera to set the white indicator level for the monitoring output by navigating through the menu system to menu number 318 and setting the value to 85.
26. Connect oscilloscope terminated with 75 Ohm to the VF output of the camera.
27. Adjust the black level of the indicators of the VF output signal to the same level as the blanking.

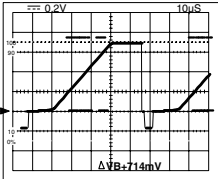
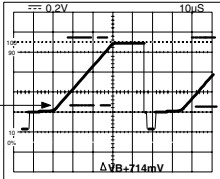
Measure at:	Adjust with:	Required result:	Correct:	Incorrect:
VF output	ZR47			

28. On connector B of the service extender remove the short circuits on the input to Video Processor 1 Board by disconnecting the jumpers from B7 to B9

B11 to B13
B17 to B19

Reconnect

- A7 to B7
- A9 to B9
- A11 to B11
- A13 to B13
- A17 to B17
- A19 to B19 on connector B of the service extender.

Video Miscellaneous Board

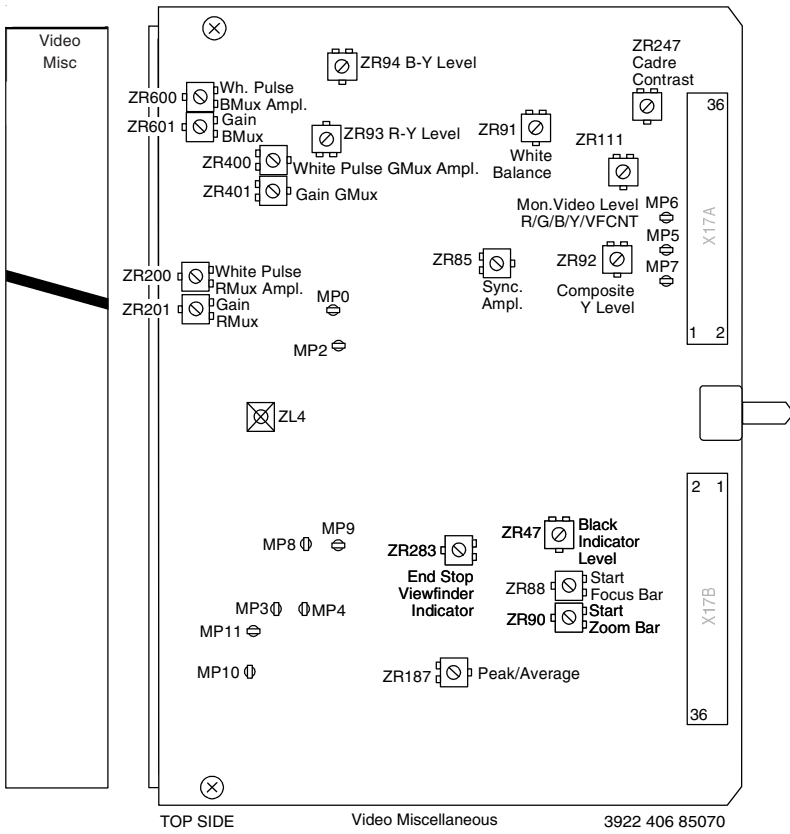

Video Miscellaneous Board

Zoom bar

29. Mount lens on camera.
30. Test sawtooth off and set filter to clear.
31. Open iris for nominal video.
32. Set potentiometers ZR90 and ZR283 to their mid-position.
33. Set lens to the wide angle position and adjust the start zoom bar potentiometer ZR90 so that there is just a small gap in the zoom bar at the left side of the viewfinder display.

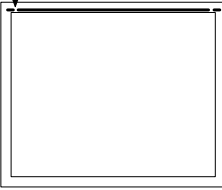
Measure at:	Adjust with:	Required result:	Correct:
VF display	ZR90		

34. Set lens to the tele position and adjust the stop zoom bar potentiometer ZR283 so that there is just a small gap in the zoom bar at the right side of the viewfinder display.

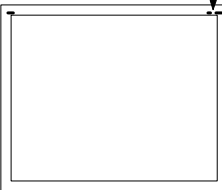
Measure at:	Adjust with:	Required result:	Correct:
VF display	ZR283		

35. Repeat steps 35 and 36 to obtain the best result.

Focus bar

36. Set lens focus to the minimum focus distance position and adjust the start focus bar potentiometer so that there is just a small gap in the focus bar at the left side of the viewfinder display.

Measure at:	Adjust with:	Required result:	Correct:
VF display	ZR88		

Sync./Shading Board

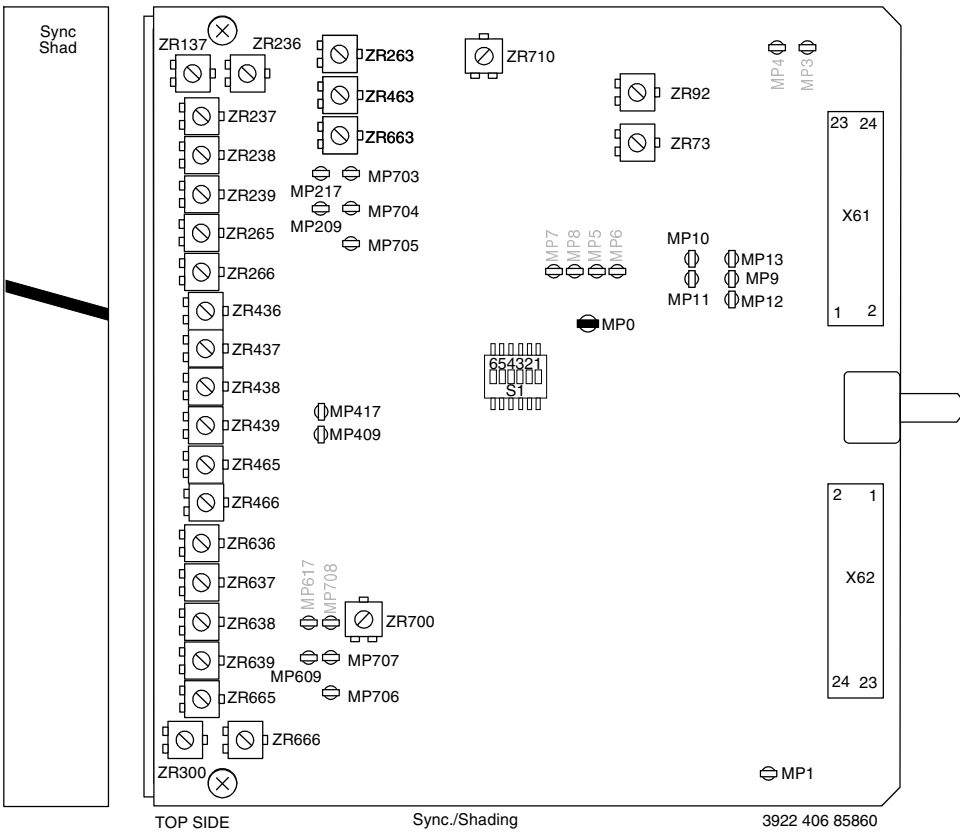

Video Processor 1 Board

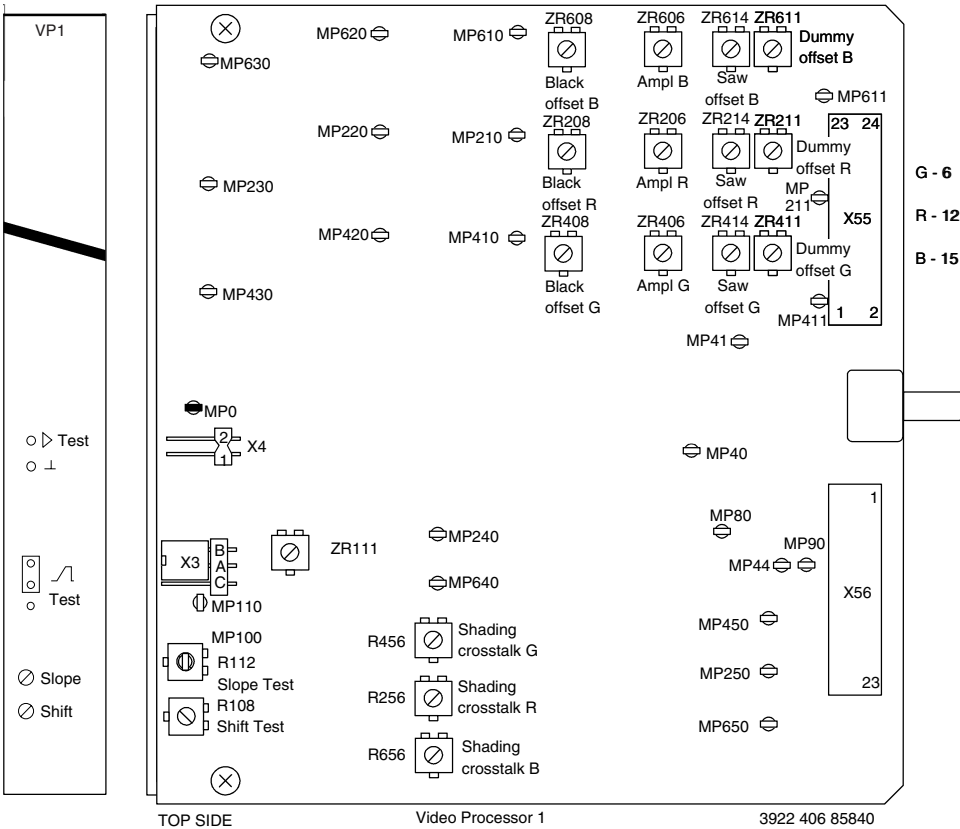

Sync./Shading Board

Setting-up

Note: Sync./Shading board must be adjusted in combination with Video Processor 1 Board.

- Put Sync./Shading Board on a service extender.
- Put Video Processor 1 Board on a service extender and remove jumpers 7, 9, 11, 13, 17 and 19 from connector B of the service extender to interrupt the input from the front and jumpers 6, 12 and 15 to interrupt the black shading correction.
- Short circuit the input to video processor 1 by connecting the following jumpers on connector B of the service extender: B7 to B9, B11 to B13, B17 to B19
- Recall Factory Standard File on MCP or OCP and close iris. On MCP set:

OPERATE MENU	Knee	:	Off	
	Contour	:	Off	
	Gamma sel.	:	Lin.	
	Blk. Str.	:	Off	
	Filter	:	Cap	
	Auto Iris	:	Off	
SETUP 1 MENU	Flare	:	Off	
	White clip	:	Off	
	Sawtooth	:	Off	
SETUP 2 MENU	Soft cont.	:	Off	
SETUP 3 MENU	Skin cont.	:	Off	
SETUP 4 MENU	Asp.Ratio	:	4:3	
SETUP 5 MENU	Matrix sel	:	1:1	
MAINT. 1 MENU	Wh. shading	:	Off	and User level : 4

Black Shading Correction

- Carry out this adjustment in an ambient temperature of 20°C / 25°C.
- On Sync./Shading Board set the DC potentiometers ZR265(R), ZR465(G) and ZR665(B) fully clockwise.
- On Sync./Shading Board set the Edge potentiometers ZR237(R), ZR437(G) and ZR637(B) fully counterclockwise.
- On Sync./Shading Board set the Pulse Comp. potentiometers ZR266(R), ZR466(G) and ZR666(B) fully counterclockwise.
- On Sync./Shading Board set Horizontal Sawtooth potentiometers ZR236(R), ZR436(G) and ZR636(B) in their midposition.
- On Sync./Shading Board adjust the horizontal sawtooth potentiometers for no sawtooth information (measure on Video Processor 1 Board).

Measure at:	Adjust with:	Required result:	
VP1	Sync./Shad.	minimum	
X55-12 (R)	ZR263 (R)	horizontal	
X55-6 (G)	ZR463 (G)	spike	
X55-15 (B)	ZR663 (B)	information	

- Adjust video level equal to blanking DC level.

Measure at:	Adjust with:	Required result:	Correct:
VP1	VP1		
X55-12 (R)	ZR211 (R)		
X55-6 (G)	ZR411 (G)		
X55-15 (B)	ZR611 (B)		

Sync./Shading Board

8. On connector B of the service extender remove the short circuits on the input to Video Processor 1 Board by disconnecting the jumpers from B7 to B9, B11 to B13 and B17 to B19,
 Reconnect A6 to B6
 A7 to B7
 A9 to B9
 A11 to B11
 A12 to B12
 A13 to B13
 A15 to B15
 A17 to B17
 A19 to B19 on connector B of the service extender.

Dummy offset adjustment

9. On Video Processor 1 Board adjust video level equal to blanking DC level.

Measure at:	Adjust with:	Required result:	Correct:
VP1	VP1	Dummy offset	
X55-12 (R)	ZR211		
X55-6 (G)	ZR411		
X55-15 (B)	ZR611		

DC level adjustment at 45°C

10. The following adjustment is temperature sensitive.
 If an oven is used to adjust at 45°C (the recommended adjustment temperature) ensure that the temperature does not rise above 45°C as this will damage the camera.
11. On Sync./Shading Board adjust the DC level potentiometer.

Measure at:	Adjust with:	Required result:	
MP209 (R)	ZR265	-250mVdc at 45°C	
MP409 (G)	ZR465	-250mVdc at 45°C	
MP609 (B)	ZR665	-250mVdc at 45°C	

12. Remove camera from oven and carry out the following adjustments while the camera is cooling down.

Pulse compensation

13. In the Install/Gain menu set the gain for + to 12dB and for ++ to 30dB
14. On MCP set:
 OPERATE MENU Gamma : 1
 Gain : Max gain
15. While switching between Nom. and 1\1000 exposure time on MCP or OCP adjust for no difference between in set-up levels (make the adjustment when the switch is in the Nom. position).

Measure at:	Adjust with:	Required result:	
VF out R	ZR266	No difference in set-up level	
VF out G	ZR466		
VF out B	ZR666		

Sync./Shading Board

Edge clip level

16. Set edge clip level potentiometers in their mid-position.

Measure at:	Adjust with:	Required result:	
VF out R	ZR237	Mid-position	
VF out G	ZR437	Mid-position	
VF out B	ZR637	Mid-position	

Edge gain correction

17. On MCP set:

OPERATE MENU

Gain : ++

Exposure : Nom.

18. Adjust the parabola correction potentiometers.

Measure at:	Adjust with:	Required result:	
VF out R	ZR239	Flat shading signal	
VF out G	ZR439		
VF out B	ZR639		

19. Adjust the edge gain vertical sawtooth potentiometers for a flat vertical shading signal.

Measure at:	Adjust with:	Required result:	
VF out R	ZR238	Flat vertical	
VF out G	ZR438	shading signal	
VF out B	ZR638		

20. Repeat steps 29. to 33. until the best result is obtained.

Hor. sawtooth correction (Nom. Exp.)

21. On Sync./Shading Board adjust the horizontal sawtooth potentiometer for no sawtooth information (Exp. Nom.).

Measure at:	Adjust with:	Required result:	
VF out R	ZR236	Flat horizontal	
VF out G	ZR436	shading signal	
VF out B	ZR636		

Hor. sawtooth correction (1/1000 Exp.)

22. Set exposure to 1/1000.

23. On Sync./Shading Board adjust the horizontal sawtooth potentiometer for no sawtooth information (Exp. 1/1000).

Measure at:	Adjust with:	Required result:	
VF out R	ZR263	Flat horizontal	
VF out G	ZR463	shading signal	
VF out B	ZR663		

Sync./Shading Board

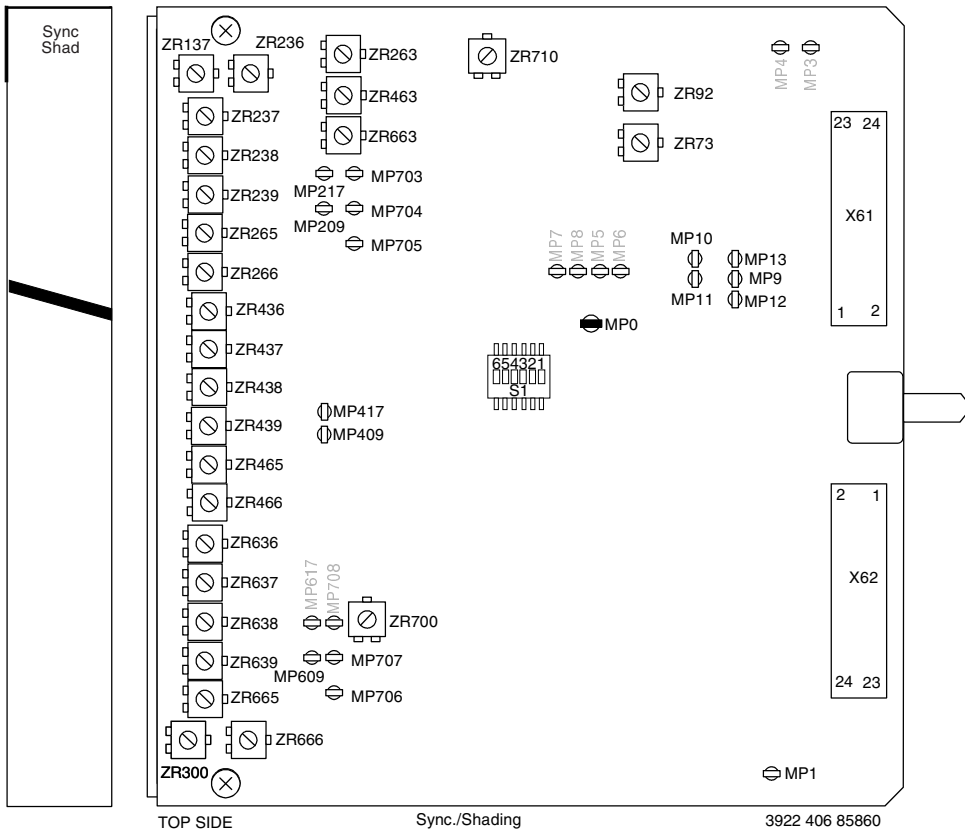

Video Processor 1 Board

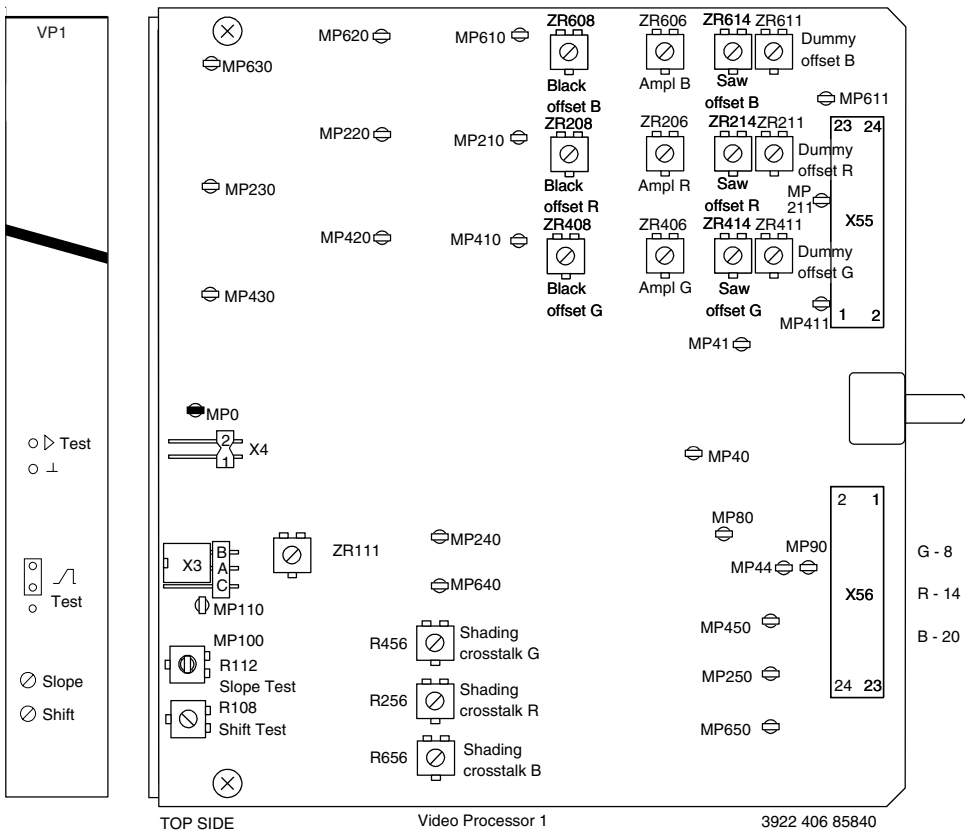

Sync/Shading Board

24. On Video Processor 1 Board adjust the vertical sawtooth potentiometer for no sawtooth information. (Select the viewfinder R, G and B output signals in the VF/Lens - VF Inst menu.)

Measure at:	Adjust with:	Required result:	
VF out R	ZR214	Video signal as flat as possible in vertical direction.	
VF out G	ZR414		
VF out B	ZR614		

Video Processor 1 Board

Black Offset

25. In the Install/Gain menu set the gain for + to 12dB and for Max gain (the standard values are 6dB and 12dB).
 26. While switching between 0dB gain and Max gain, adjust black level during the active line to the same as the clamp level.

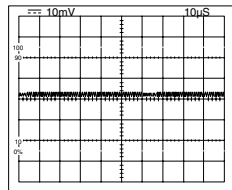
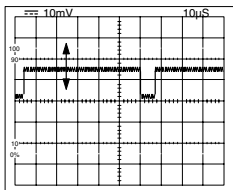
Measure at:	Adjust with:	Required result:	Correct:	Incorrect:
X56-14(R)	ZR208 (R)	0mV (R)		
X56-8(G)	ZR408 (G)	0mV (G)		
X56-20(B)	ZR608 (B)	0mV (B)		

Note: When the standard file is recalled the black levels are set as follows: Master=50, R=50, G=50, B=50.

Sync/Shading Board

27. In the Install/Gain menu reset the gain for + to 6dB and for ++ to 12dB.
 28. Switch to Aspect Ratio 16:9 and check black shading.
 29. Remove sync/shading board and Video Processor 1 board from service extender and return it to its position in the camera.

White shading exposure

30. Mount lens on camera. Switch on power.
 Recall Factory Standard File on MCP or OCP or Camera.
 On MCP set:
 OPERATE MENU
 Knee : Off
 Gamma : Lin.
 Auto Iris : Off
 Exposure : 1/1000
 SETUP 5 MENU
 Matrix : 1:1
 MAINT 1 MENU
 Wh. shading : On
31. Point camera at a white uniformly illuminated test chart (preferable a spherical illuminator). Set diaphragm to F5.6 and zoom for no vignetting. Adjust illumination for an 80% video level.
 32. Select the red viewfinder signal.
 33. Observe the CVBS output on the waveform monitor and adjust the frame flicker potentiometer for minimum flicker between odd and even fields.

Measure at:	Adjust with:	Required result:	
CVBS out	R300	Minimum variation between fields	

Video Miscellaneous Board

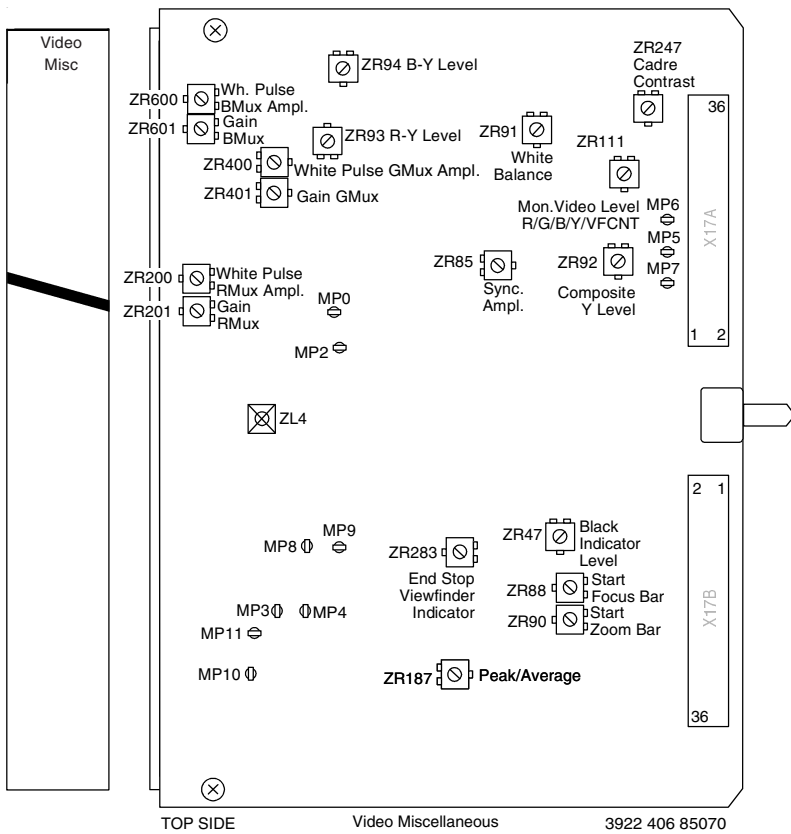

Video Miscellaneous Board

Auto iris

1. Point camera at and fill frame with a white 90% reflecting test chart, illuminated with a 3200K spotlight. Set iris to F5.6.

Measure at:	Adjust with:	Required result:	
CVBS out		Waveform monitor 100% video level.	

2. On OCP, ensure that the IRIS CENTRE control is turned fully counterclockwise and the IRIS RANGE control is turned fully clockwise. Move iris control first fully up and then fully down. Then set iris control to its mid-position.
3. On OCP, switch AUTO IRIS to AUTO.
4. Observe waveform monitor and adjust auto iris level on camera control panel for 70% white with setpoint potentiometer.

Measure at:	Adjust with:	Required result:	
CVBS out	Setpoint pos. = 42	70% white (490mV)	

5. On OCP, set COLOUR TEMP. switch to position AW1.
6. Press AW button once so that the AW window is visible in the viewfinder and on the PXM monitor.
7. Press the AW button a second time to start the automatic white process.
8. During the automatic white process observe the waveform monitor. The mom. iris should be 70% white.

Measure at:	Adjust with:	Required result:	
CVBS out		70% white (490mV)	

9. Point camera at gamma test chart illuminated with a 3200K spotlight.
10. Observe waveform monitor and with the peak/average value set to 50 on the camera control panel, adjust the peak/average potentiometer on the miscellaneous board for 90% white.

Measure at:	Adjust with:	Required result:	
CVBS out	ZR187	90% white (630mV)	

Encoder Board PAL

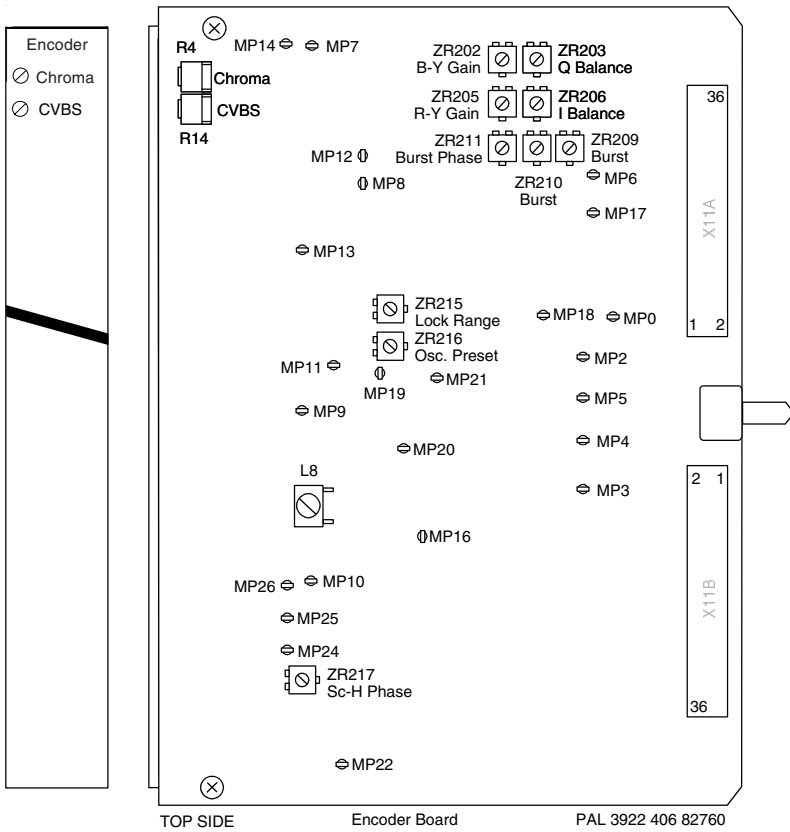

Encoder Board PAL

Set-up

1. Switch off power. Place encoder board on service extender. Genlock camera with black burst signal. Switch on power.
2. Connect oscilloscope via a vectorscope terminated with 75Ohm to the CVBS output of the camera.
3. Switch on colour bar.

Black balance

4. Turn chroma potentiometer R4 on encoder board fully clockwise (max. chroma).
5. Adjust the I and Q balance potentiometers for minimum unbalance in black.

Measure at:	Adjust with:	Required result:	
CVBS out	ZR203 ZR206	Smallest possible dot in centre of vectorscope	

6. Turn chroma potentiometer R4 on encoder board fully counterclockwise (zero chrominance).

CVBS amplitude

7. Adjust the CVBS gain potentiometer to obtain an output amplitude of 700mV for Y.

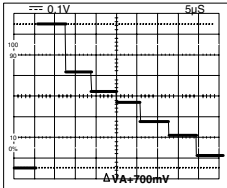
Measure at:	Adjust with:	Required result:	Correct:
CVBS out	R14	700mV	

R-Y amplitude

8. Turn R-Y gain potentiometer ZR205 fully clockwise.
9. Connect MP7 on the encoder board to ground.
10. Adjust with the chroma potentiometer until the colour vector dots correspond with the indication marks on the V-axis of the graticule.

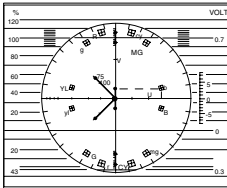
Measure at:	Adjust with:	Required result:	Correct:
CVBS out	R4		

Encoder Board PAL

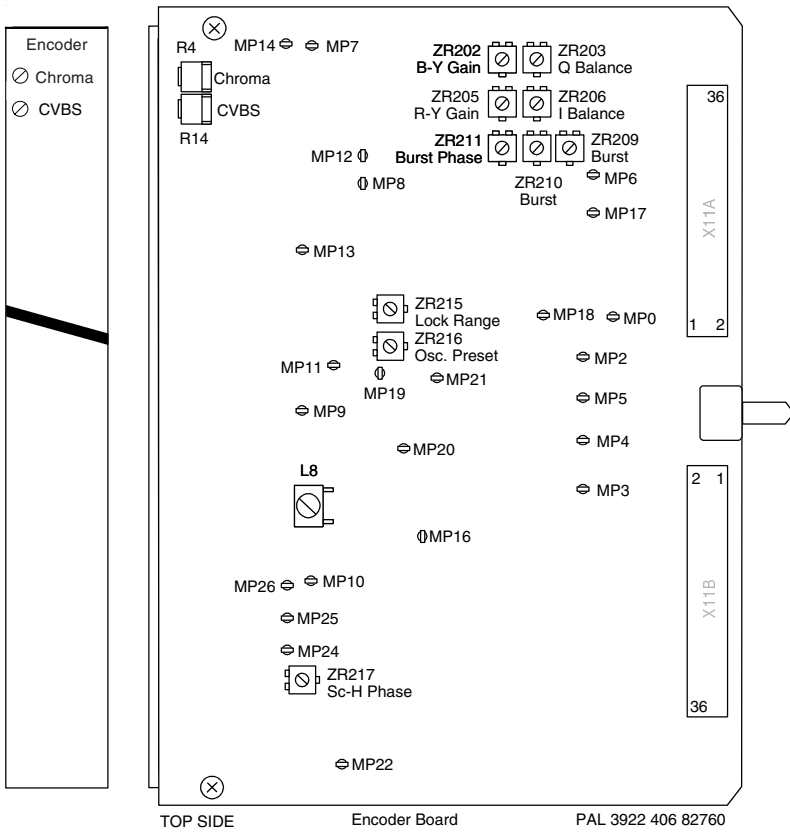

Encoder Board PAL

B-Y amplitude

- On the encoder board disconnect MP7 from ground and connect MP8 to ground.
- Adjust with the B-Y gain potentiometer until the colour vector dots correspond with the indication marks on the U-axis of the graticule.

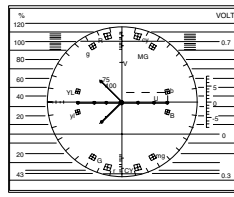
Measure at:	Adjust with:	Required result:	Correct:
CVBS out	ZR202		

- Disconnect MP8 from ground.

R-Y / B-Y phase

- Switch vectorscope from Standard to PAL mode.
- If the vector dots are not superimposed on each other adjust the phase with L8.

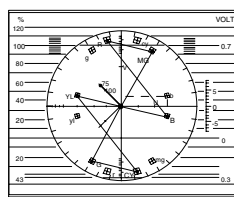
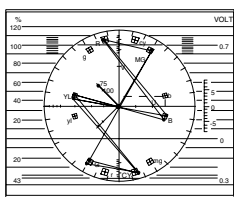
Measure at:	Adjust with:	Required result:	Correct:	Incorrect:
CVBS out	L8			

- Switch vectorscope from PAL to Standard mode and check that the vector dots are exactly in the vectorscope boxes.

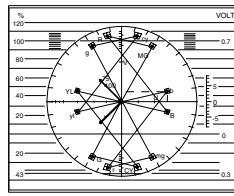
Measure at:	Adjust with:	Required result:	Correct:
			

BURST ADJUSTMENTS

Burst phase

- Measure in second quadrant of vectorscope.
Adjust the input sensitivity potentiometer of the vectorscope so the burst vectors just touch the circle graticule.
- Adjust the burst phase potentiometer for 90° phase output.

Measure at:	Adjust with:	Required result:	Correct:
CVBS out	ZR211		

Encoder Board PAL

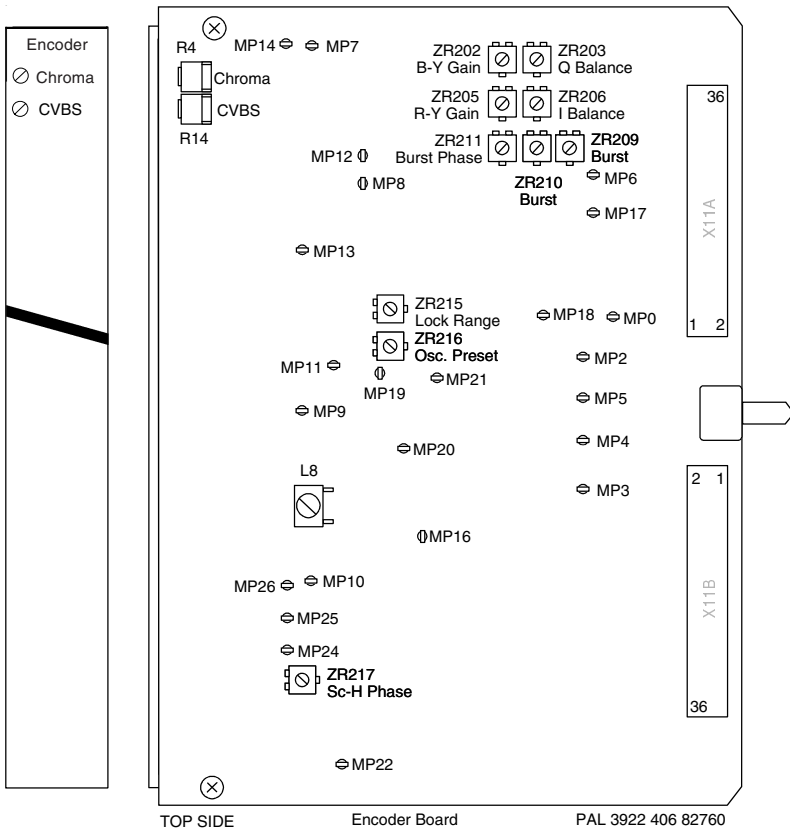

Encoder Board PAL

Burst amplitude

19. Adjust the burst amplitude potentiometer to obtain a burst amplitude of 300mV.

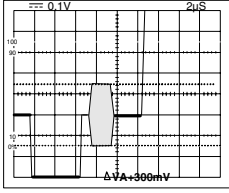
Measure at:	Adjust with:	Required result:	Correct:
CVBS out	ZR210	300mV	

Burst timing

20. Observe waveform monitor or oscilloscope and adjust the burst position so that it is 5.6µs from the leading edge of the line synchronisation.

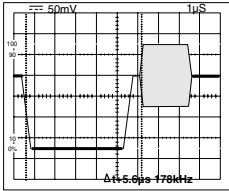
Measure at:	Adjust with:	Required result:	Correct:
CVBS out	ZR209		

Genlock free-running preset

21. Remove genlock signal from camera.

22. Turn lock range potentiometer ZR215 fully counterclockwise.

23. Observe colour monitor, waveform monitor or vectorscope and adjust oscillator preset potentiometer.

Measure at:	Adjust with:	Required result:	Correct:
CVBS out	ZR216	Minimum freerunning speed	

Sc-H phase relationship

24. Switch vectorscope to internal synchronisation.

25. Adjust Sc-H phase potentiometer for 180°.

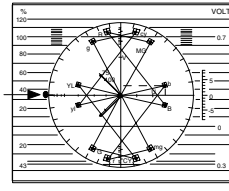
Measure at:	Adjust with:	Required result:	Correct:
CVBS out	ZR217		

26. Switch off power and return encoder board to its position in the camera.

Encoder Board NTSC

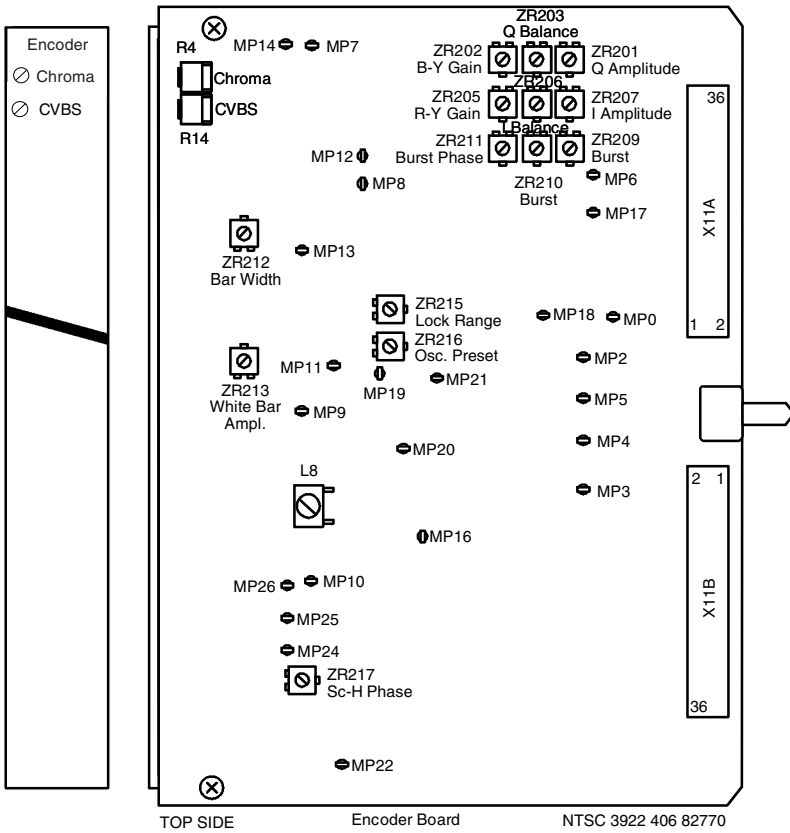

Encoder Board NTSC

Set-up

1. Switch off power. Place encoder board on service extender. Genlock camera with black burst signal. Switch on power.
2. Connect oscilloscope via a vectorscope terminated with 75Ohm to the CVBS output of the camera.
3. Switch on colour bar.

Black balance

4. Turn chroma potentiometer R4 on encoder board fully clockwise (max. chroma).
5. Adjust the I and Q balance potentiometers for minimum unbalance in black.

Measure at:	Adjust with:	Required result:	
CVBS out	ZR203 ZR206	Smallest possible dot in centre of vectorscope	

6. Turn chroma potentiometer R4 on encoder board fully counterclockwise (zero chrominance).

CVBS amplitude

7. Adjust the CVBS gain potentiometer to obtain an output amplitude of 549mV (77 IRE).

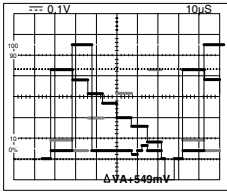
Measure at:	Adjust with:	Required result:	Correct:
CVBS out	R14	549mV (77 IRE)	

White bar amplitude

8. Adjust the white amplitude potentiometer to obtain an output of 714mV (100 IRE).

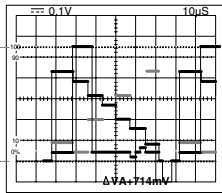
Measure at:	Adjust with:	Required result:	Correct:
CVBS out	ZR213	714mV	

Encoder Board NTSC

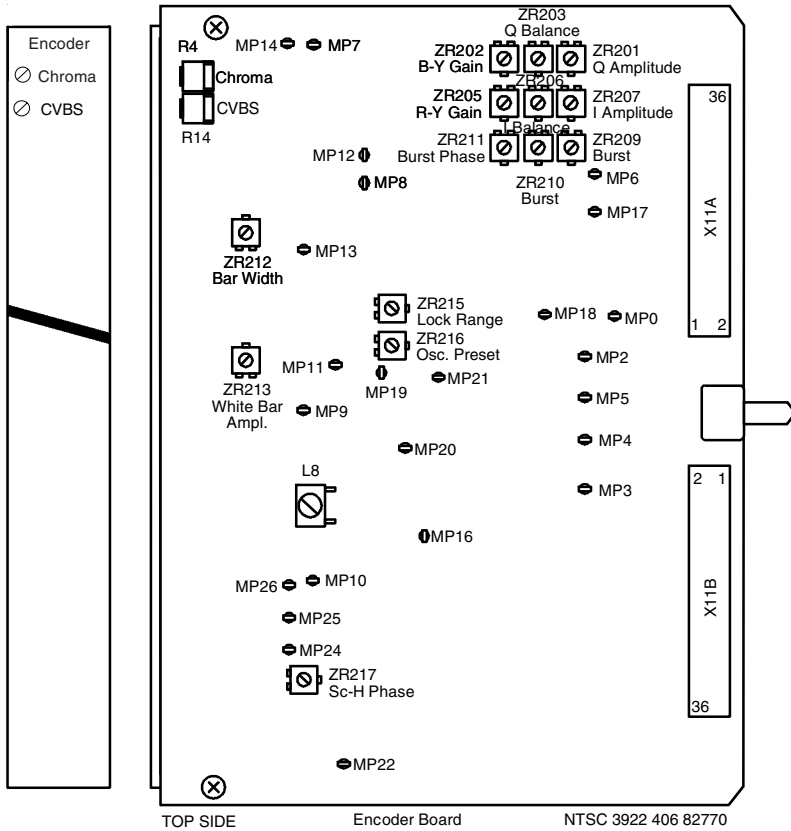

Encoder Board NTSC

I amplitude

9. Set I gain potentiometer ZR205 in its mid-position.
10. Connect MP7 on the encoder board to ground.
11. Adjust with the chroma potentiometer until the colour vector dots correspond with the indication marks on the I-axis of the graticule.

Measure at:	Adjust with:	Required result:	Correct:
CVBS out	R4		

Q amplitude

12. On the encoder board disconnect MP7 from ground and connect MP8 to ground.
13. Adjust with the Q gain potentiometer until the colour vector dots correspond with the indication marks on the Q-axis of the graticule.

Measure at:	Adjust with:	Required result:	Correct:
CVBS out	ZR202		

14. Disconnect MP8 from ground and check that the SMPTE colour bar signal is correct.

SMPTE bar shift

15. Adjust the SMPTE shift so that the PLUGE signal is within the red bar.

Measure at:	Adjust with:	Required result:	Correct:
CVBS out	ZR212		

Encoder Board NTSC

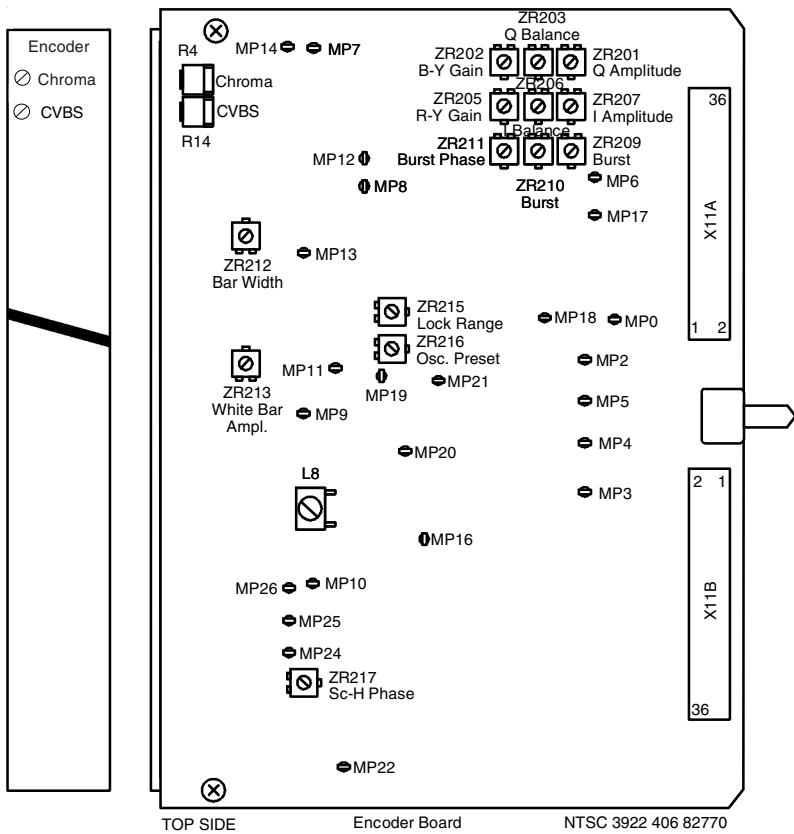

Encoder Board NTSC

I / Q 90° phase

16. Connect MP7 on the encoder board to ground.
17. With the phase potentiometer on the vectorscope, place the I vectors along the I-axis of the graticule.

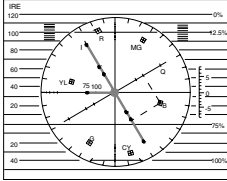
Measure at:	Adjust with:	Required result:	Correct:
			

18. On the encoder board disconnect MP7 from ground and connect MP8 to ground.
19. Adjust the phase of the Q vectors with L8 so that they lie along the Q-axis of the graticule.

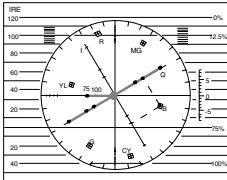
Measure at:	Adjust with:	Required result:	Correct:
CVBS out	L8		

20. Repeat steps 16. to 20. until the best results are obtained.

BURST ADJUSTMENTS

Burst phase

21. Adjust the burst phase potentiometer to place the burst vector along the horizontal axis

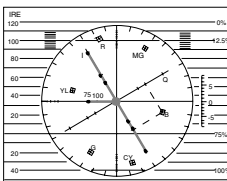
Measure at:	Adjust with:	Required result:	Correct:
CVBS out	ZR211		

Burst amplitude

22. Adjust the burst amplitude potentiometer to obtain a burst amplitude of 286mV (40 IRE).

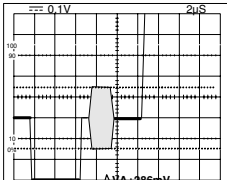
Measure at:	Adjust with:	Required result:	Correct:
CVBS out	ZR210	286mV (40 IRE)	

Encoder Board NTSC

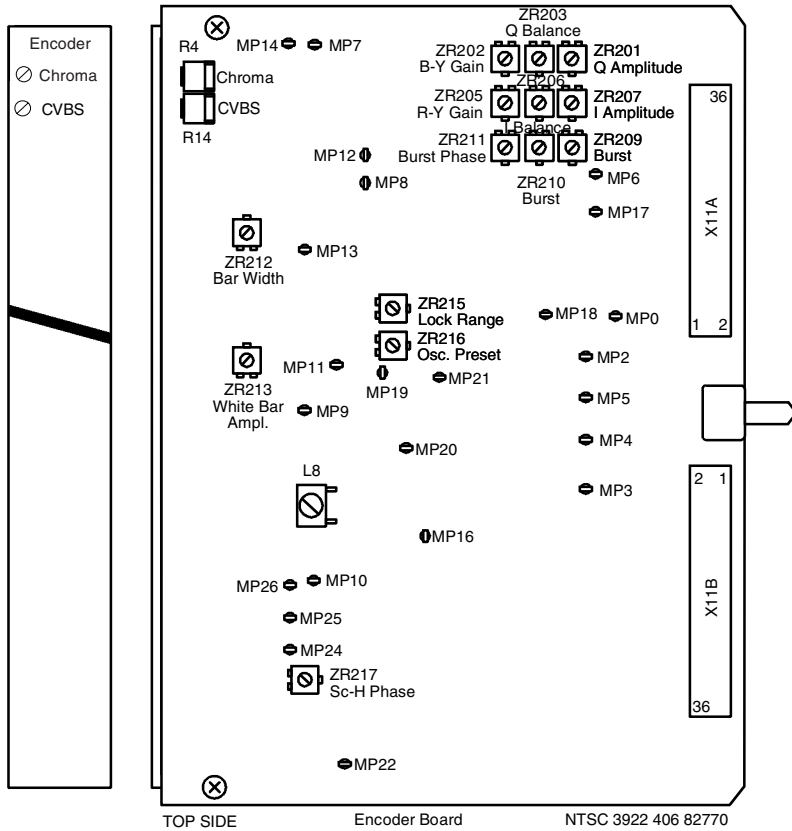

Encoder Board NTSC

Burst timing

23. Observe waveform monitor or oscilloscope and adjust the burst position so that it is $5.3\mu\text{S}$ from the leading edge of the line synchronisation.

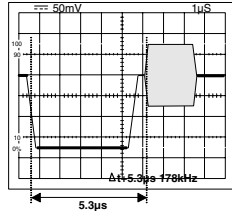
Measure at:	Adjust with:	Required result:	Correct:
CVBS out	ZR209	$5.3\mu\text{S}$	

Genlock free-running preset

24. Remove genlock signal from camera.
 25. Turn lock range potentiometer ZR215 fully counterclockwise.
 26. Observe colour monitor, waveform monitor or vectorscope and adjust oscillator preset potentiometer for minimum free-running.

Measure at:	Adjust with:	Required result:	Correct:
CVBS out	ZR216	Minimum free-running speed	

I/Q bar amplitude

27. Adjust the I and Q bars for an amplitude of 286mV (40 IRE).

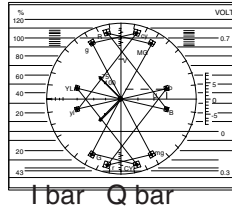
Measure at:	Adjust with:	Required result:	Correct:
CVBS out	ZR207	I-bar amplitude	
CVBS out	ZR201	Q-bar amplitude	

28. Switch off power and return encoder board to its position in the camera.

Audio/Intercom LF Board

Set-up

1. Set up camera in triax mode. Switch off power.
Place audio/intercom LF board on service extender. Switch on power.

Audio 1 level

2. Select an audio 1 level of -64dBu.
3. Apply a 1kHz test signal at -64dBu symmetrical to the audio 1 input of the camera
4. Adjust the audio preset potentiometer for a 1kHz signal at -12dBu on the audio 1 output pin.

Measure at:	Adjust with:	Required result:	
X19A-35	ZR110	-12dBu	

Audio 1 limiter

5. Apply a 1kHz test signal at -46dBu to the audio 1 input of the camera.
6. Adjust the limiter potentiometer for a 1kHz signal at 0dB on audio 1 output pin.

Measure at:	Adjust with:	Required result:	
X19A-35	ZR160	0dBu	

Audio 2 level

7. Select an audio 2 level of -64dBu.
8. Apply a 1kHz test signal at -64dBu symmetrical to the audio 2 input of the camera
9. Adjust the audio preset potentiometer for a 1kHz signal at -12dBu on the audio 2 output pin.

Measure at:	Adjust with:	Required result:	
X19A-33	ZR210	-12dBu	

Audio 2 limiter

10. Apply a 1kHz test signal at -46dBu to the audio 2 input of the camera.
11. Adjust the limiter potentiometer for a 1kHz signal at 0dB on audio 2 output pin.

Measure at:	Adjust with:	Required result:	
X19A-33	ZR260	0dBu	

Audio/Intercom LF Board

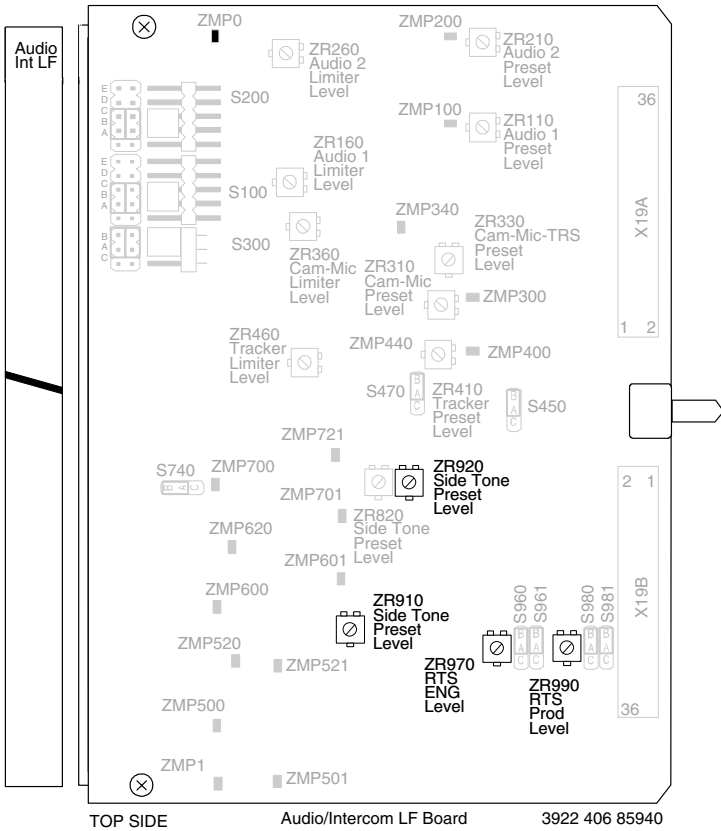

Jumper settings:

S300	Camera Menu
Cam. + Tracker Mic. Phantom Power	Cam. Mic. Gain
A-C: +12V A-B: Gnd	40dB 0dB
Camera Menu	S470
Tracker Mic. Gain	Signal Choice
40dB 0dB	AB: Sidetone AC: ENG
S450	S740
Signal Choice	Signal Choice
AB: Tracker Mic. AC: Private Data	AB: Prog. AC: Private Data
S960	S961
Signal Choice Floor L	Signal Choice Floor L
AB: Headset AC: RTS	AB: Headset AC: RTS
S980	S981
Channel Choice Floor R	Channel Choice Floor R
AB: Headset AC: RTS	AB: Headset AC: RTS

Audio/Intercom LF Board

Cameraman intercom microphone

- Apply a 1kHz test signal at -64dBu to the cam. intercom mic. input of Audio/Intercom LF Board (X19A-25).
- Adjust the cam. mic. preset potentiometer for a 1kHz signal at -6dBu on the microphone output pin of the board.

Measure at:	Adjust with:	Required result:	
X19B-10	ZR310	-6dBu	

Cameraman intercom microphone PL

- Adjust the side tone potentiometer for a 1kHz signal at 0dBu on the telephone output pin.

Measure at:	Adjust with:	Required result:	
X19B-13	ZR920	0dBu	

Limiter level camera microphone

- Apply a 1kHz test signal at -52dBu to the cam. intercom mic. input of Audio/Intercom LF Board (X19A-25).
- Adjust the cam. mic. limiter level potentiometer for a 1kHz signal at 0dB the microphone output pin of the board.

Measure at:	Adjust with:	Required result:	
X19B-10	ZR360	0dBu	

Cameraman intercom microphone TRS

- Apply a 1kHz test signal at -64dBu to the cam. intercom mic. input of Audio/Intercom LF Board (X19A-29).
- Adjust the cam. mic. preset potentiometer for a 1kHz signal at -6dBu on the microphone output pin of the board.

Measure at:	Adjust with:	Required result:	
X19B-10	ZR330	-6dBu	

Tracker intercom microphone

- Apply a 1kHz test signal at -64dBu to the tracker intercom mic. input of Audio/Intercom LF board (X19A-13).
- Adjust the tracker mic. preset potentiometer for a 1kHz signal at -6dBu on the mic. output pin of the board.

Measure at:	Adjust with:	Required result:	
X19B-8	ZR410	-6dBu	

Tracker intercom microphone PL

- Adjust the tracker preset potentiometer for a 1kHz signal at 0dBu on the telephone cam. output pin.

Measure at:	Adjust with:	Required result:	
X19B-16	ZR820	0dBu	

Tracker intercom microphone PL (sidetone)

- Adjust the tracker mic. sidetone level potentiometer for a 1kHz signal at 0dBu on the output pin of the board.

Measure at:	Adjust with:	Required result:	
X19B-13	ZR910	0dBu	

Limiter level tracker microphone

- Apply a 1kHz test signal at -52dBu to the tracker intercom mic. input of Audio/Intercom LF board (X19A-13).
- Adjust the tracker mic. limiter level potentiometer for a 1kHz signal at 0dB on the microphone output pin of the board.

Measure at:	Adjust with:	Required result:	Correct:	Incorrect:
X19B-8	ZR460	0dBu		

- Switch off power. Return Audio/Intercom LF Board to its position in the camera.

—Audio/Intercom LF Board RTS MODE—

Cameraman intercom microphone PL

1. Apply a 1kHz test signal at -64dBu to the cam. intercom mic. input of Audio/Intercom LF Board (X19A-25).
2. Adjust the cam. mic. preset potentiometer for a 1kHz signal at -10dBu on the microphone output pin of the board.

Measure at:	Adjust with:	Required result:	
X19B-13	ZR920	-10dBu	

Tracker intercom microphone PL

3. Apply a 1kHz test signal at -64dBu to the tracker intercom mic. input of Audio/Intercom LF board (X19A-13).
4. Adjust the tracker mic. sidetone potentiometer for a 1kHz signal at -10dBu on the mic. output pin of the board.

Measure at:	Adjust with:	Required result:	
X19B-13	ZR910	-10dBu	

CH1 fork attenuation PROD

5. Apply a 1kHz test signal at -6dBu to the prod intercom input of Audio/Intercom LF board (X19B-28).
6. Adjust the fork attenuation level potentiometer for a 1kHz signal <-22dBu at the output pin of the board.

Measure at:	Adjust with:	Required result:	Correct:	Incorrect:
X19B-8	ZR990	<-22dBu		

CH2 fork attenuation ENG

5. Apply a 1kHz test signal at -6dBu to the eng intercom input of Audio/Intercom LF board (X19B-30).
6. Adjust the fork attenuation level potentiometer for a 1kHz signal <-35dBu at the output pin of the board.

Measure at:	Adjust with:	Required result:	Correct:	Incorrect:
X19B-8	ZR970	<-35dBu		

22. Switch off power. Return Audio/Intercom LF Board to its position in the camera.

Pre Processor Board

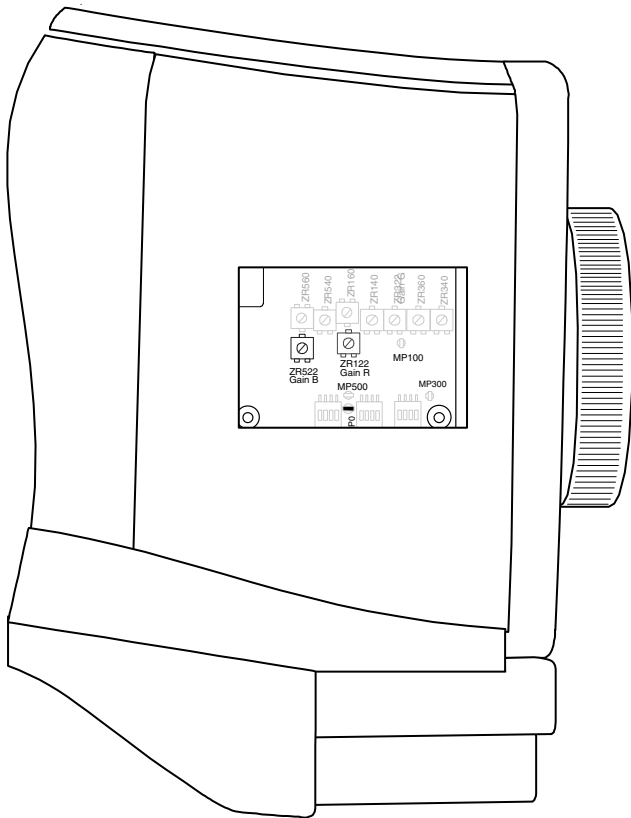

Pre-Processor Board

Gain Adjustment

1. Recall Factory Standard File on MCP or OCP.

On MCP set:

OPERATE MENU

Knee : Off
Auto Iris : Off
Matrix sel. : 1:1

SETUP 1 MENU

Wh. Limiter : Off
Gamma : Lin.

SETUP 4 MENU

Asp. ratio : 4:3

2. Set the lighting conditions for 100% video output as follows:

Colour temp. : 3200K
Illumination : 2000lux
Lens aperture : F8
Scene reflection : Reference white 90% (Minolta reference white tile)

(2000 Lux with 90% reflectance is 573 cd/m²)

3. Open the right side cover of the camera.
4. Remove adjustment hatch on right side of front module of the camera.
5. Place Video Miscellaneous Board on a service extender
6. Open Iris at the lens to obtain 700mV at X17A point 19 of Video Miscellaneous Board (Green)

Measure at:	Adjust with:	Required result:	Correct:	Incorrect:
<u>Vid.Misc.</u>	<u>Pre-Proc.</u>			
X17A-23 (B)	ZR522	700mV		
X17A-27 (R)	ZR122	700mV		

7. Replace adjustment hatch on right side of front module of the camera.
8. Return Video Miscellaneous Board to its position in the camera.
9. Close camera right side cover.
10. Recall Factory Standard File on MCP or OCP.

Section 5

Drawings

This section contains block diagrams of the camera. The block diagrams are a useful help for tracing signals when fault finding.

Contents

Block Diagram Power Signals	5-2	Block Diagram Transmission Signals	5-4
Block Diagram Video Signals	5-3	Block Diagram Control Signals	5-5

Block Diagram Power Signals

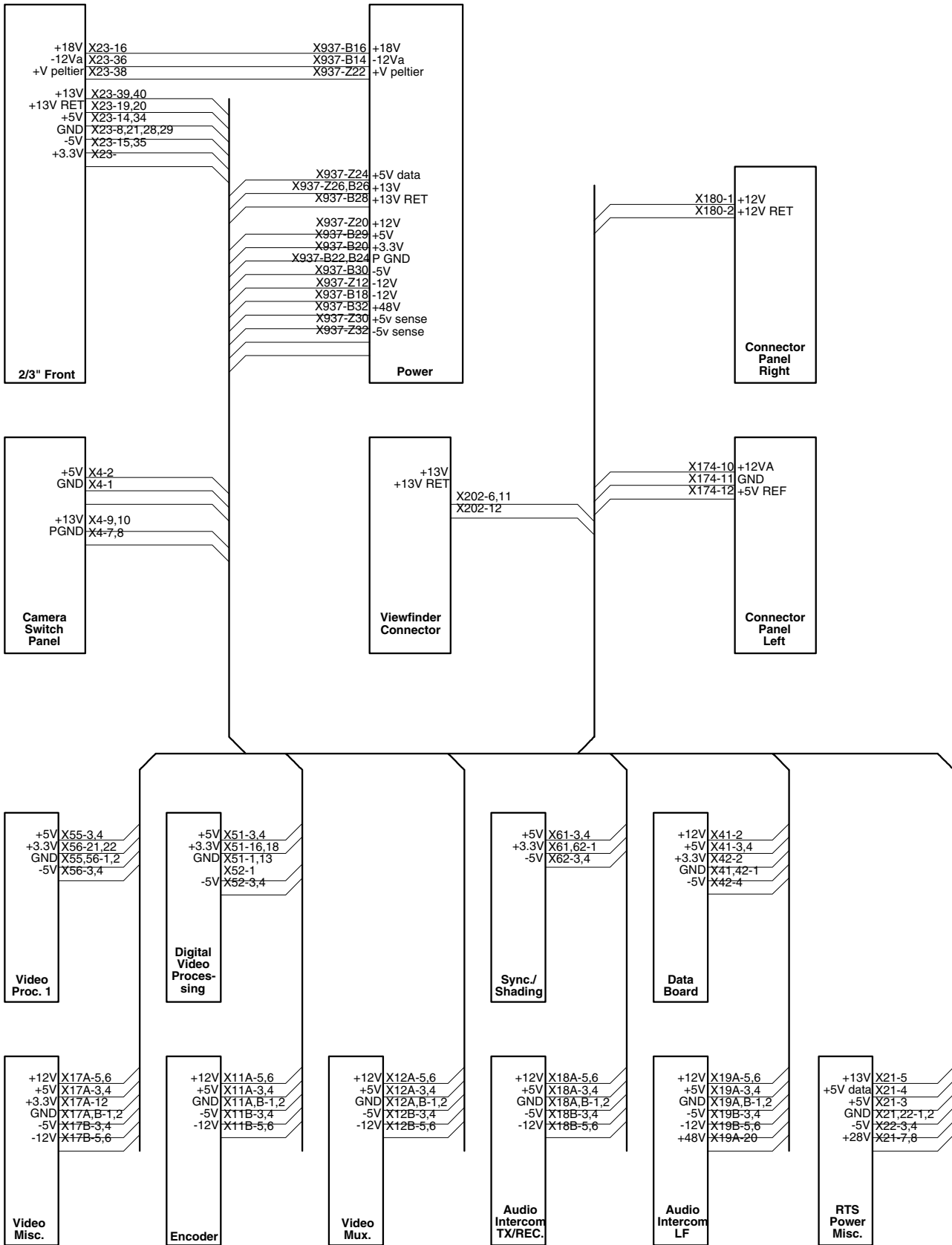

Block Diagram Transmission Signals

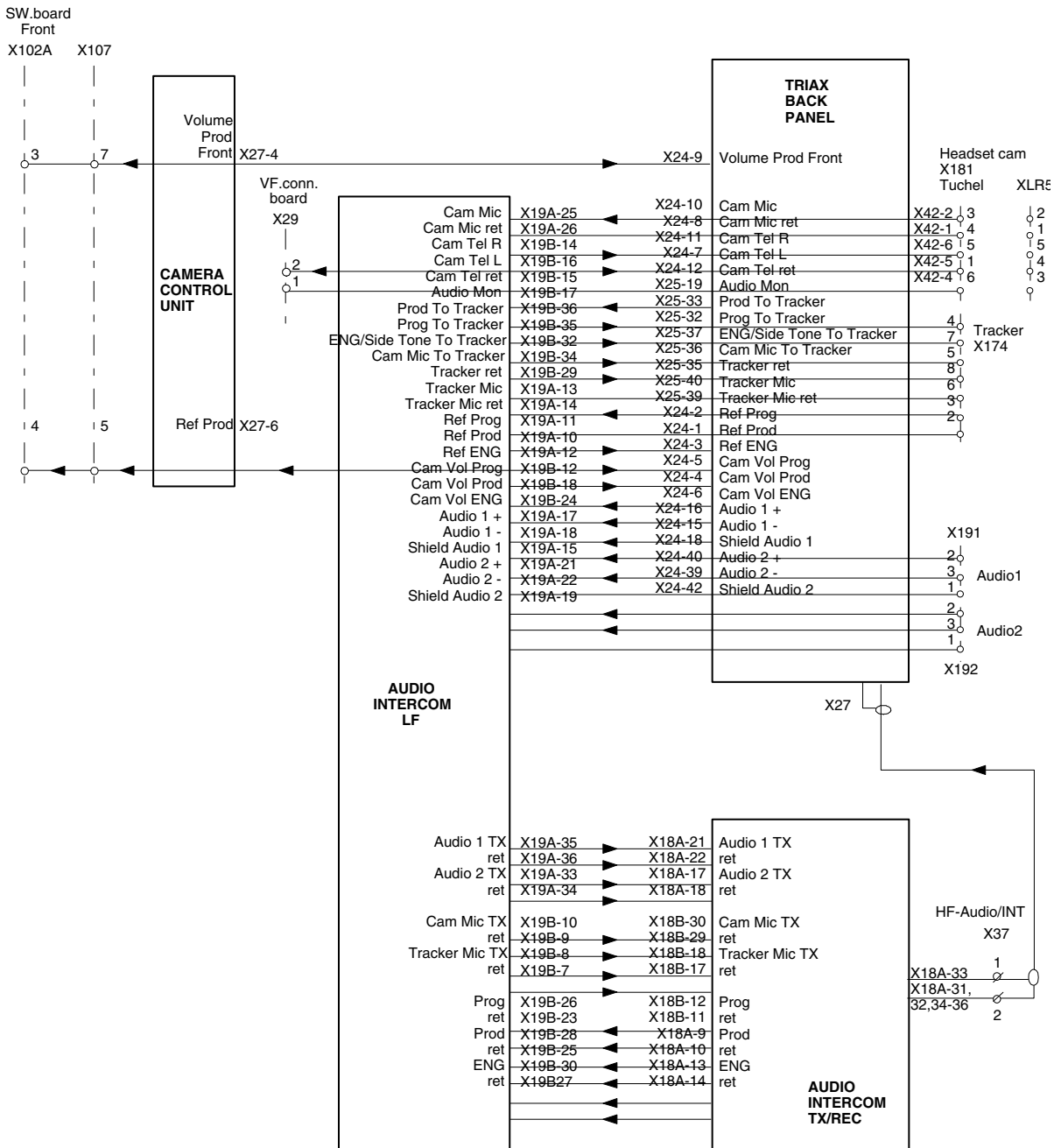

Block Diagram Control Signals

