

LDK 200

Multi-role Digital Camera Head



Operator's Manual

3922 496 47941 St.00

Declaration of Conformity

We, Thomson Broadcast Solutions Nederland B.V., Kapittelweg 10, 4827 HG Breda, The Netherlands declare under our sole responsibility that this product is in compliance with the following standards:

- EN60065 : Safety
- EN55103-1 : EMC (Emission)
- EN55103-2 : EMC (Immunity)

following the provisions of:

- a. the Safety Directives 73/23/EEC and 93/68/EEC
- b. the EMC Directives 89/336/EEC and 93/68/EEC

FCC Class A Statement

This product generates, uses, and can radiate radio frequency energy and if not installed and used in accordance with the instructions, may cause interference to radio communications.

It has been tested and found to comply with the limits for a class A computing device pursuant to Subpart J of part 15 of FCC rules, which are designed to provide reasonable protection against such interference when operated in a commercial environment.

Operation of this product in a residential area is likely to cause interference in which case the user at his own expense will be required to take whatever measures may be required to correct the interference.

Copyright

Für diese Unterlage behalten wir uns alle Rechte vor (Gemäß DIN 34). Technische Änderungen im Zuge der Weiterentwicklung vorbehalten.

Copying of this document and giving it to others, and the use or communication of the contents thereof, are forbidden without express authority. Offenders are liable to the payment of damages. All rights are reserved in the event of the grant of a patent or the registration of a utility model or design. Liable to technical alterations in the course of further development.

Toute communication ou reproduction de ce document, toute exploitation ou communication de son contenu sont interdites, sauf autorisation expresse. Tout manquement à cette règle est illicite et expose son auteur au versement de dommages et intérêts. Tous nos droits sont réservés pour le cas de la délivrance d'un modèle d'utilité. Sous réserve de modification au cours de l'évolution technique.

LDK 200 Multi-role Digital Camera Head

Operator's Manual

Contents

About this Manual	ii		
Introduction	1-1	Audio	4-3
Technology	1-2	Intercom	4-3
Smart Card	1-3	Video Functions	4-4
Features	1-4	Viewfinder	4-7
Important Precautions	1-5	Viewfinder Indicators	4-8
		Control Functions	4-9
Assembling the Units	2-1	Shooting	5-1
Transport Case	2-2	Using the Camera	5-2
Lens	2-3	Standard settings	5-3
1.5-inch Viewfinder	2-4	Colour Bar	5-4
1.5-inch Viewfinder Accessories	2-5	Gain selection	5-4
Microphone	2-6	Optical filter selection	5-4
Tripod Adapter Plate	2-7	Colour temperature selection	5-5
SuperXPander	2-8	Auto-White Balance	5-5
Shoulder Pad	2-9	Shooting Screens	5-6
Rain and Off-use Cover	2-9	Exposure Time	5-6
Zoom Controls	2-10		
Top Light	2-10	Using the Menu System	6-1
		Introduction	6-2
Configurations	3-1	Systems Menu	6-3
Basic Configurations	3-2		
		Appendix	A-1
Location of Controls and Functions	4-1	List of Abbreviations	A-2
Power Supply	4-2		
Security and Access	4-2		

About this Manual

This operator's manual is part of a complete documentation set for the camera which also includes a Technical Manual, and a Service Manual.

Purpose of this manual

The purpose of this manual is to present a detailed description of how to operate the LDK 200 Multi-role Digital Camera head. It provides the information necessary to use the camera in different configurations and with various attachments. With this manual it is possible to discover all the operating features of the camera and so use it to its full potential. The manual should be used together with the camera to explore and learn about the many sophisticated control functions available.

Intended audience

This operator's manual can be used by inexperienced camera operators who are new to Thomson Multimedia Broadcast Solutions cameras as well as those who have previous experience of operating cameras. The guide is so designed that it can be used as an introduction to those who are new to the camera, as a simple procedural guide to those who wish to set-up and start shooting immediately, and as a reference work to be consulted as required during the long life of the camera.

Structure of this manual

The manual is divided into six sections and an appendix:

Section 1: Introduction

This section outlines the technology used in the LDK 200 camera and how this translates into a practical, useable camera. It lists the main features of the camera and also the precautions that must be taken into account when using it.

Section 2: Assembling the Units

Section 2 provides information on the physical assembly of the camera and on how accessories can be used to expand the possibilities of the camera. The mounting of accessories and packing for transport is also explained.

Section 3: Configurations

The LDK 200 is a multi-functional camera and this section describes the various ways that it can be used. Information on the cables, control panels and the control bus is also provided as is information on the main video and audio signal paths through the system.

Section 4: Location of Controls and Functions

This section shows the physical location of the controls and connectors on the camera. These are grouped according to their function so as to provide a quick reference guide to the operation of a particular aspect of the camera.

Section 5: Shooting

This section contains information on the practical use of the camera using the viewfinder display and the switches to control the camera.

Section 6: Operating the Menu System

Because the LDK 200 offers such a wide range of functions, this section describes the structure of the control system.

Appendix

The appendix contains a list of Abbreviations used in this manual.

Section 1

Introduction

This section outlines the technology used in the LDK 200 Digital Camera Head and how this translates into a practical, useable camera. It lists the main features of the camera and also the precautions that must be taken into account when using it.

Contents

Technology	1-2	Features	1-4
Smart Card	1-3	Important Precautions	1-5

The LDK 200 camera is a multi-role digital camera head using 2/3-inch CCD sensors. This flexible camera head is equally at home in the studio or out on location in an OB environment.

Frame Transfer DPM sensor

The Frame Transfer CCD DPM sensor offers superior performance and can handle highlights of up to 600%. The 2/3-inch sensors have a high dynamic range and high linear sensitivity over all camera lens apertures. Frame Transfer technology ensures that there is no lag nor smear. The Frame Transfer DPM sensor uses Dynamic Pixel Management which allows the format of the sensors to be switched between 4:3 and 16:9 aspect ratios at the touch of a switch without loss of horizontal or vertical resolution. The 1000 pixels per line in both formats ensures that there is no loss in the horizontal viewing angle but also ensures high resolution in the red, green and blue channels.

Digital Processing

The advanced digital processing of the camera is based on 12-bit A/D converters and more than 20-bit internal processing. Two DSPs combine all major camera functions in the digital domain, including knee, gamma, contour, matrix and colour correction.

The intelligent continuous automatics facility provides automatic control of black levels and black shading. Each sensor provides black reference signals that are used to monitor temperature changes. This means that continuous automatic correction is applied without operator intervention.

The digital contour processing uses full amplitude video RGB signals via an extended dynamic range contour circuit.

Colorimetry is selected by means of a variable 6-point digital matrix or via preset matrices. Digital gamma circuits provide a wide range of standardised gamma curves and enable soft contrast in black scenes to be enhanced, together with hard contrast and saturated colour in bright scenes. The matrix and gamma sequence is software programmable for precise colour matching.

Film-like characteristics

The pivoting knee circuit adapts both the knee point and the compression ratio according to the highlight content of the picture to emulate the softly limiting S-shaped transfer characteristics of film. Digital True Colour Knee circuitry maintains the correct hue for compressed highlights, reproducing colours faithfully, even overexposed skin tones.

Digital contrast circuitry provides a black stretch function for more detail in black areas and a black press function for improving the contrast impression by simulating the S-curve of film.

Smart Card

Three smart cards are delivered with each camera. These comprise of two user cards and one owner card.

The owner's smart card has three functions:

- As an access control device to the security settings of the camera.
- As a storage device for four scene files.
- As a storage device for two operator files.

The owner card is unique to every camera. Owner card and camera must have the same serial number.

The user smart card has two functions:

- As a storage device for four scene files.
- As a storage device for two operator files.

Access control

The owner card is used to set the user level. There are four user levels present in the camera. These restrict access, in varying degrees, to the operational controls. The Appendix indicates which functions are available at each user level. (The owner card also gives access to a service level; refer to the Technical Manual for more information about this level.)

Scene files

Both the user card and the owner card allow four different scene files to be stored on the card. The recall and storage of a scene file is carried out via the Files menu of the menu system. A scene file contains information relating to the video settings.

Operator files

Both the user card and the owner card allow two different operator files to be stored on the card. The recall and storage of an operator file is carried out via the Files menu of the menu system. An operator file contains information relating to the set-up of general camera preferences.

Note:

Only use an original Thomson camera card.
Store the owner card in a safe place.

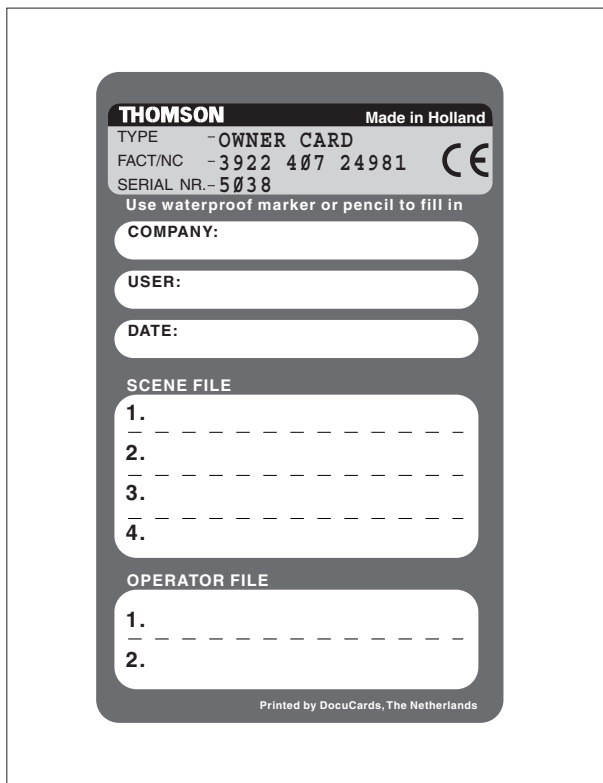

Ownercard

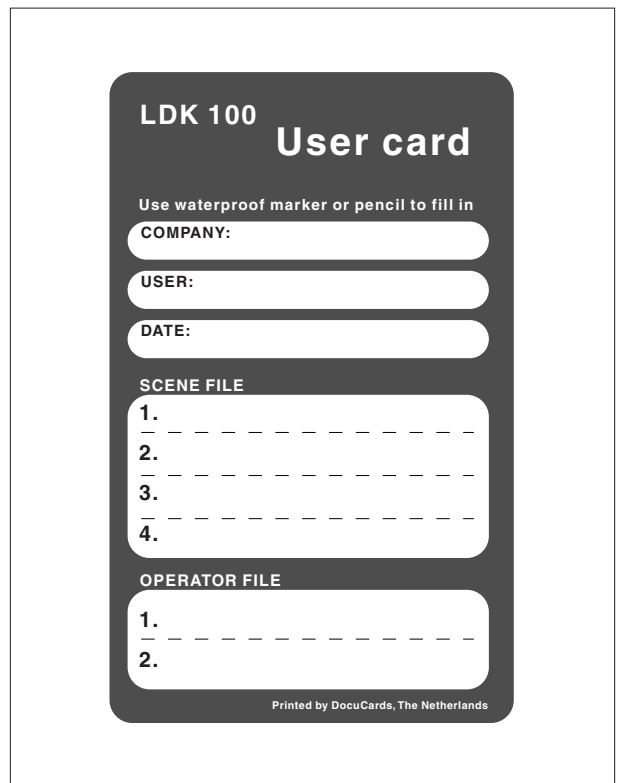

User card

Features

- 3x 2/3-inch switchable DPM sensors ensure no vertical smear.
- DPM Frame Transfer sensors with 1000 horizontal pixels in 4:3 and 16:9 aspect ratios, and the same number of vertical lines in both formats. No change in horizontal viewing angle - so no optical wide angle convertors required.
- 12-bit digital processing with unique software programmable video path.
- Superior all digital highlight handling with a wide dynamic range.
- Unique circuitry for pivoting knee and True Colour Knee.
- Wide range of presets and variable 6-point digital matrix assure accurate colour matching.
- Fluorescent light matrix
- Digital gamma with unique standard preset values and highest accuracy.
- Digital contour with an extensive range of parameters.
- Advanced contour correction includes two automatic skin settings.
- Intelligent Continuous Automatics black levels, black shading and video levels - no set-up time required.
- Digital contrast with standard black stretch and black press.
- International standard 2/3-inch lens interface.
- Optical servo-controlled four-position neutral density filter wheel.
- Optical servo-controlled effect filter wheel with soft focus, four-point star and six-point star filters.
- Electronic colour filter can be used for creating a special look (warm / cold) of a scene, or for a smooth colour temperature control around the white balance setting.
- Smart card for personal settings and security.
- Owner card for setting user levels, and for copying and storing control settings.
- Protected, easy-to-operate controls and switches with read-out of all settings.
- Viewfinder status read-out of primary camera functions.
- Clean scan feature allows capture of computer and other monitor pictures.
- Digital RS 232 interface to PC.

Options

- Zoom control handgrip makes awkward shots easy.
- Transport case.
- SuperXPander extends the camera's use in studio and EFP situations.
- Smart-Touch™ gives the operator instant, one-button access to 14 predefined shooting characteristics.

Important Precautions

To ensure continual high performance from the camera take the following precautions into consideration:



Avoid very damp places. If the environment is wet or damp a rain cover must be used to protect the unit.



Do not subject the unit to severe shocks or vibration.



Do not expose the camera to extremes of temperature.



Do not leave the unit in direct sunlight or close to heating appliances for extended periods.



Do not allow sunlight to shine into the viewfinder.

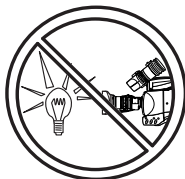

Avoid extreme highlights as these can cause various kinds of optical reflections.

WARNINGS

If the unit is in a wet or damp environment, a rain cover must be used to protect it for personal safety reasons (EN60065). The rain cover supplied with the unit protects it according to safety specification EN60529 up to level IPX2 (spraying water).

Section 2

Assembling the Units

Section 2 provides information on the physical assembly of the camera and on how accessories can be used to expand the possibilities of the camera. The mounting of accessories and packing for transport are also explained.

Contents

Transport Case	2-2	SuperXPander	2-8
Lens	2-3	Shoulder Pad	2-9
1.5-inch Viewfinder	2-4	Rain and Off-use Cover	2-9
1.5-inch Viewfinder Accessories	2-5	Zoom Controls	2-10
Microphone	2-6	Top Light	2-10
Tripod Adapter Plate	2-7		

Transport Case

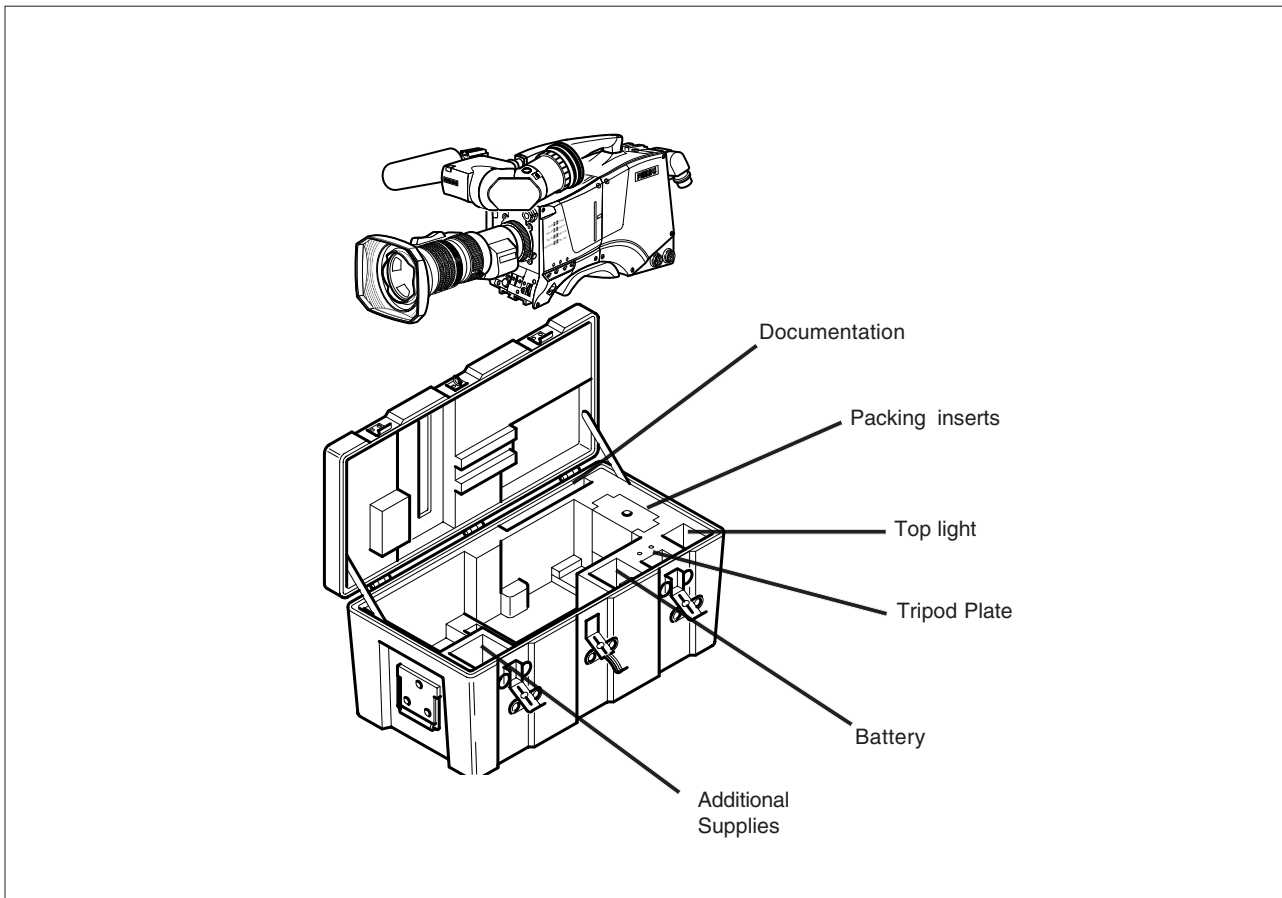

It is important to protect your camera against damage when transporting it. To do this, a transport case (LDK 5020/00) is optionally available for the camera, lens, viewfinder and some accessories.

The camera is packed in the transport case as shown in the figure above. This ensures that the camera is not damaged during transport.

Turn the 1.5-inch viewfinder downwards so that it does not protrude above the top of the camera.

Several foam packing inserts are provided to enable different configurations of the camera to be packed securely. These inserts are used to support the rear of the camera. Make sure you use the correct foam insert for your particular configuration.

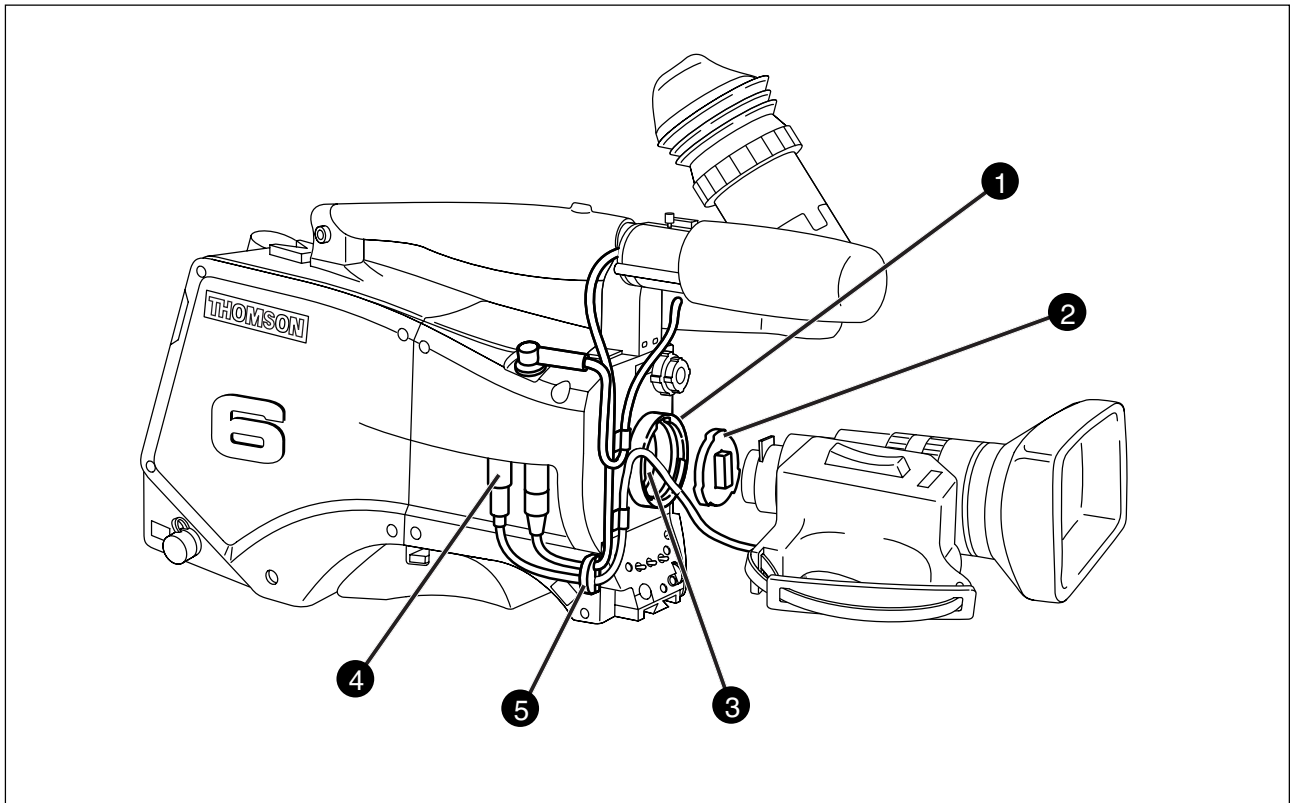

To attach a lens to the camera head proceed as follows:

- a. Ensure that the lens locking ring ❶ is in the unlocked position - turned counterclockwise.
- b. Remove the dust protection cap ❷.
- c. Slot the lens into the lens mount ❸.
- d. Turn the lens locking ring ❶ clockwise to lock the lens in place.
- e. Connect the lens cable to the lens connector ❹ at the right side of the camera.
- f. Place the lens cable into the bottom clip at the front of the camera and clip ❺ located at the side. (Pull and twist clip ❺ to open it.)

Caution

Do not attach a lens weighting more than 5 kg to the camera without a support.

When a new lens is fitted to the camera it may be necessary to carry out some adjustments to optimize its use, for example, back focus or shading. For more information about these adjustments refer to Section 5 and to the lens manufacturer's documentation

Note

Always mount the dust protection cap when the lens is not connected to the camera.

1.5-inch Viewfinder

Mounting the 1.5-inch viewfinder and microphone holder

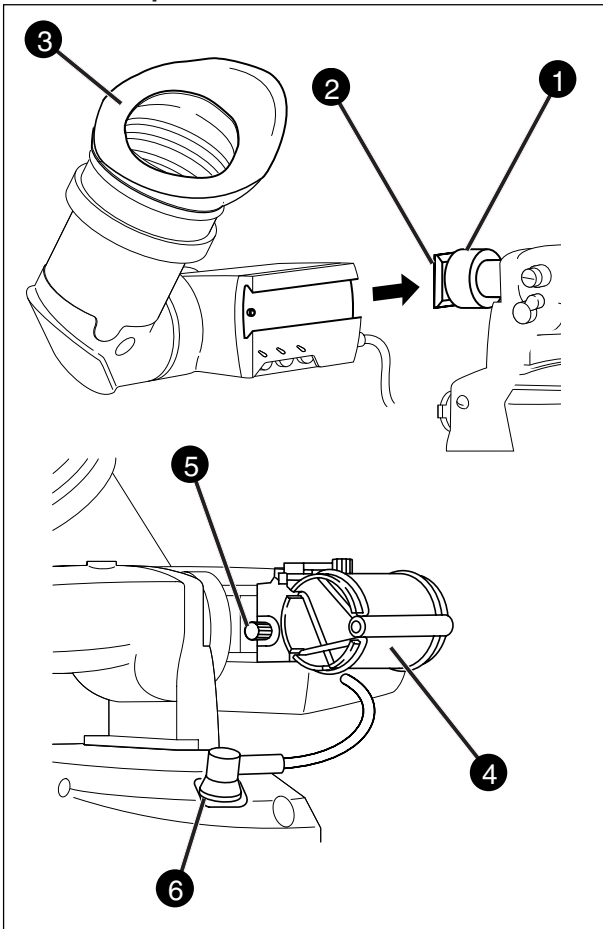

- To mount the 1.5-inch viewfinder proceed as follows:
- Loosen locking ring ① of viewfinder support bracket ② at the front of the camera handle. (As seen from the rear of the camera, turning the locking ring counterclockwise moves it towards the handle.)
 - Slide the viewfinder onto the viewfinder support bracket.
 - Tighten the locking ring ① by turning it clockwise (as seen from rear) so that the viewfinder is mounted securely to the support.
 - Connect the viewfinder cable to the viewfinder connector socket ⑥ at the top right of the camera.
 - Slide the microphone holder ④ onto the viewfinder and secure with the knurled screw ⑤.

Caution

Always fit the microphone holder ④ as it functions as a safety stop for the viewfinder.

- To improve the comfort of the skin contact when using the viewfinder, fit the eye piece cover ③ to the rubber eyepiece. Spare eye piece covers (3922 405 00461) are available at your Thomson Multimedia Broadcast Solutions representative.

Positioning the 1.5-inch viewfinder

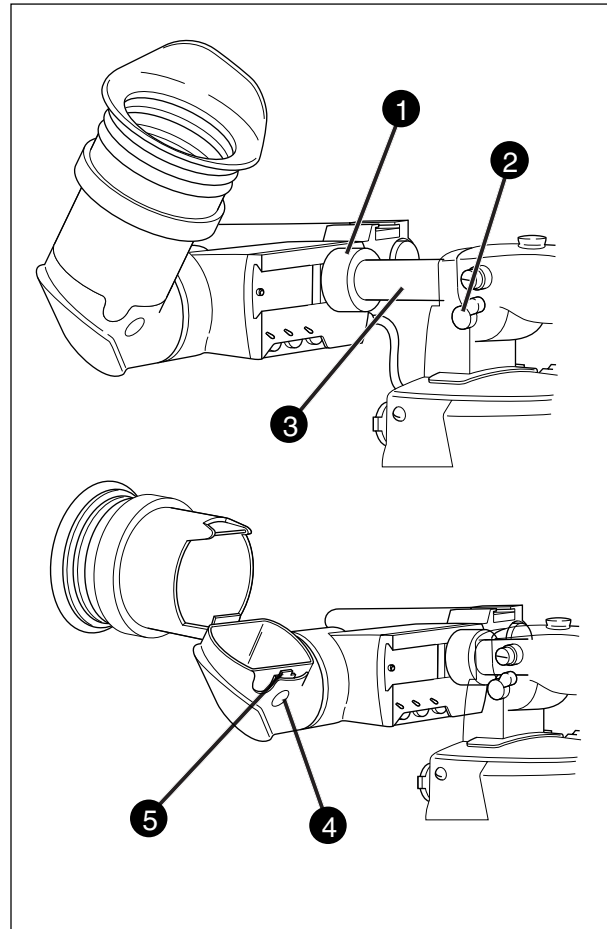

The horizontal position of the viewfinder can be adjusted as follows to suit your requirements:

- Loosen the locking ring ①. (As seen from the rear of the camera, turning the locking ring counterclockwise moves it towards the handle.)
- Slide the viewfinder horizontally along the rail to the desired position.
- Tighten the locking ring ① by turning clockwise.

The dioptre hood and eyepiece of the viewfinder can be rotated vertically.

The viewfinder can be positioned backwards and forwards along the camera axis. Loosen the support bracket round bar retaining lever ② and slide the round bar ③ forwards or backwards. When the desired position is reached tighten the support bracket round bar retaining lever ② again.

To use the viewfinder at a distance press the button ④ below or above the eyepiece tube and swing it free of the associated clip ⑤. The display can now be seen from further away.

—1.5-inch Viewfinder Accessories

Wide angle eyepiece

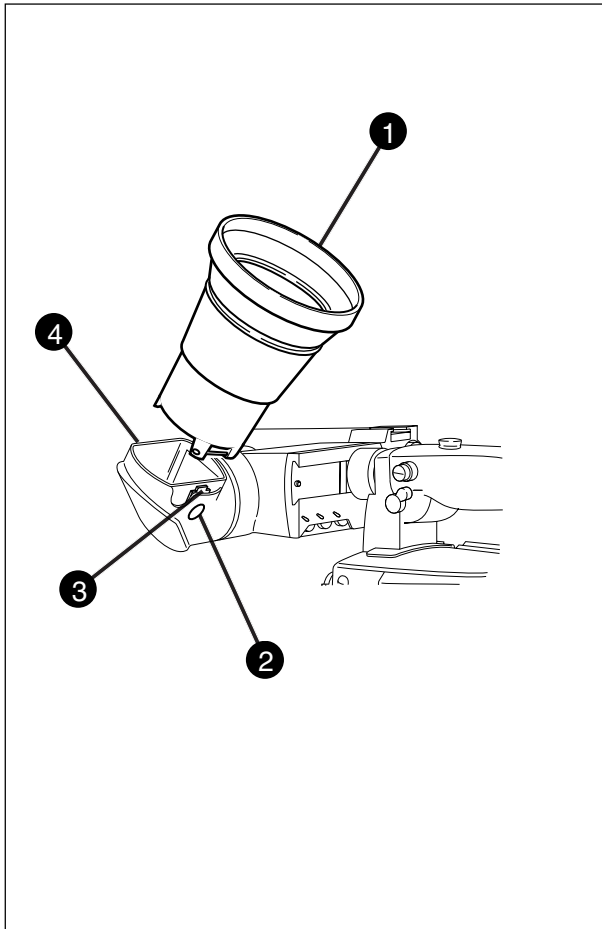

If you regularly use the viewfinder at a distance, for example, when you use the camera in the hand-held position, it is recommended that you fit the optionally available wide angle eyepiece (LDK 5390/00).

To fit the wide angle eyepiece proceed as follows:

- Hold the eyepiece ① securely.
- Press the button ② below the eyepiece tube and swing it free of the button clip ③.
- Press the button ④ above the eyepiece tube and remove the eyepiece.
- Fit the wide angle eyepiece ① to the two clips ③ ensuring that they both click into place.

Left eye adapter

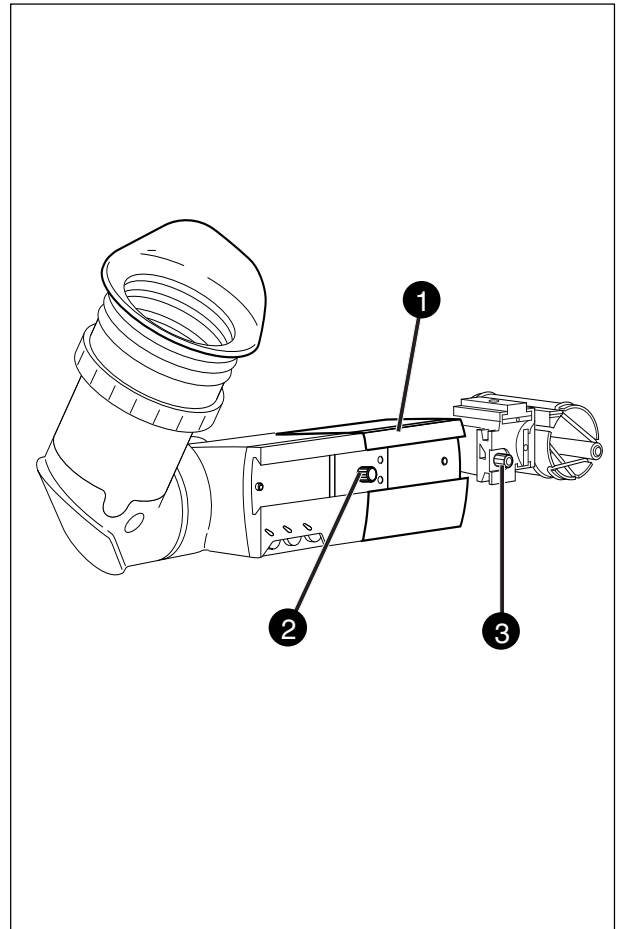

A left eye adapter is optionally available (LDK 5390/10) to allow the viewfinder to be used with the left eye.

Before mounting the viewfinder onto the camera, attach the left eye adapter ① to the viewfinder and secure it using the screw ②. Do not forget to mount the microphone support bracket ③ at the end of the left eye adapter.

Microphone

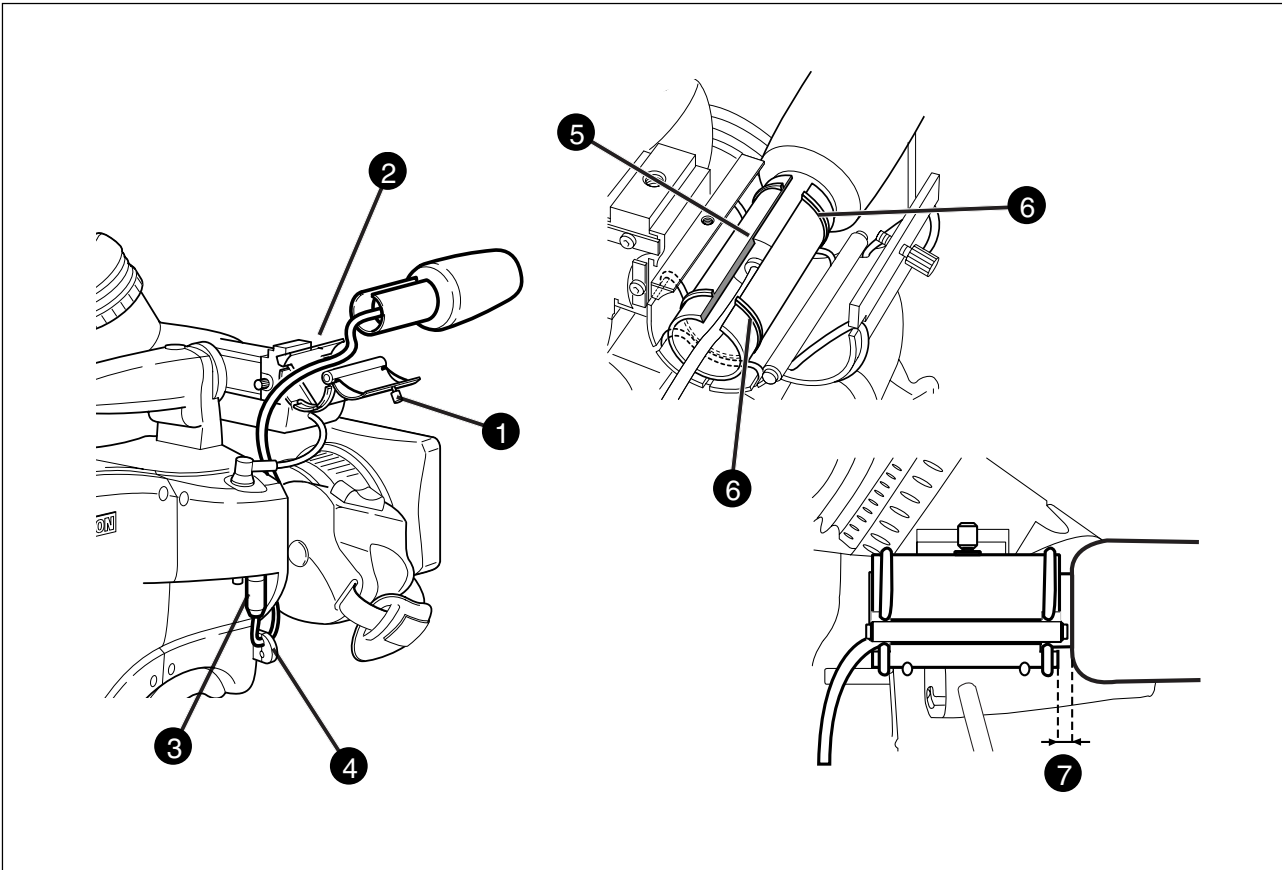

To attach the optional microphone (AJ MC700) to the camera proceed as follows:

- a. Open the microphone holder by unscrewing the knurled screw ① of the microphone support bracket ② on the viewfinder and open.
- b. Slide the microphone into the split tube until the microphone shoulder reaches the mark ⑤ in the tube.
- c. Place the tube with the microphone into the holder with the split facing upwards.
- d. Ensure that the rubber supports at the back and front of the holder fit into the rims ⑥ around the tube.
- e. Close the holder and tighten the knurled screw at the top.
- f. Connect the microphone cable to audio connector ③ (mic) on the right side of the camera.
- g. Place the microphone cable into the top clip at the front of the camera and into clip ④ at the side of the camera. (Pull and twist clip ④ to open it.)

Other microphones with a diameter of 21mm can also be used, however, ensure that the phantom power and the sensitivity of the input that match that type of microphone are correctly selected in the camera systems menu. Refer to Section 6 for more information on selecting the audio inputs and controlling the audio level.

Note:

- When longer microphones are used, it is not necessary to place them in the split tube.
- For optimum operation, the microphone should be mounted as straight as possible.
- Don't allow the wind hood to touch the holder ⑦ as this reduces the damping effect.
- By placing the split facing upwards, the microphone cable does not touch the holder thus avoiding mechanical pick-up.

Tripod Adapter Plate

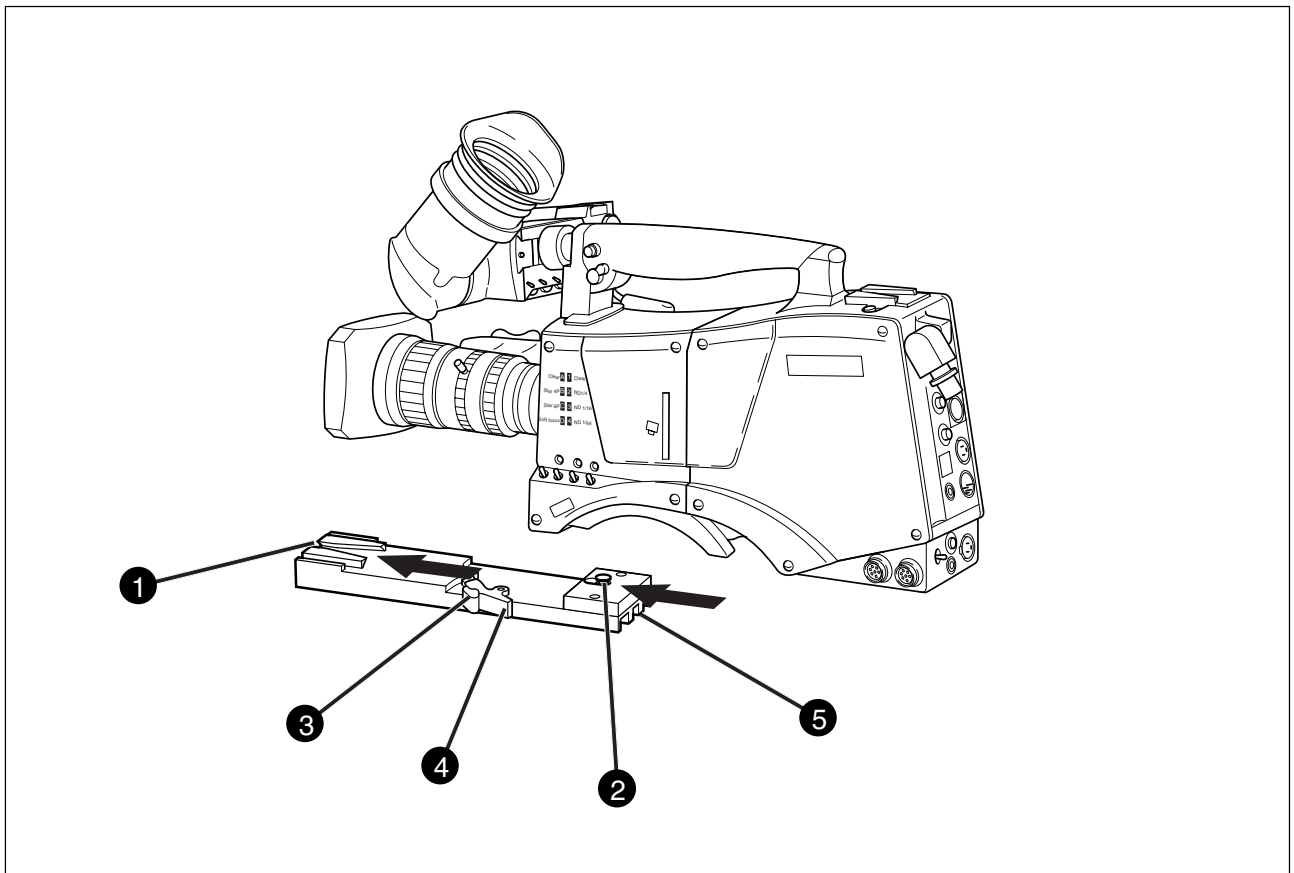

To mount the camera on a tripod, the tripod plate (LDK 530/00 is delivered as standard) must first be attached to the tripod.

Follow the tripod manufacturer's instructions to mount the wedge plate supplied with the tripod and the tripod adapter plate firmly onto the tripod.

To attach the camera to the tripod adapter plate proceed as follows:

- Slide the camera horizontally along the tripod adapter plate from back to front ensuring that the front of the camera engages the V-slot ① at the front of the tripod adapter plate, and that the slot on the bottom of the camera engages the stud ② at the rear of the tripod adapter plate.
- Firmly push the camera forward until it clicks into place.

CAUTION

Failure to attach the camera to the tripod adapter plate in the correct manner could result in an unsecured camera. Ensure that the rear stud ② is engaged and that the camera clicks into place.

To remove the camera from the tripod proceed as follows:

- Press the red locking lever ③ against release handle ④ on the tripod adapter plate and hold.
- Ensure that you have a firm hold of the camera.
- Pull the release handle ④ forward.
- Move the camera backwards and up. The camera is now free from the tripod adapter plate.

When a 5-inch viewfinder is used with the camera it is recommended that the optionally available tripod adapter plate LDK 5030 be used. This tripod plate has an extra locking lever ⑤ at the rear which provides an additional clamp for the rear stud and so gives extra stability to the mount.

When the camera is mounted on the tripod tighten this locking lever ⑤ to ensure that the stud ② at the rear of the plate is locked firmly in place.

When removing the camera first open the locking lever ⑤ to free the rear stud ②.

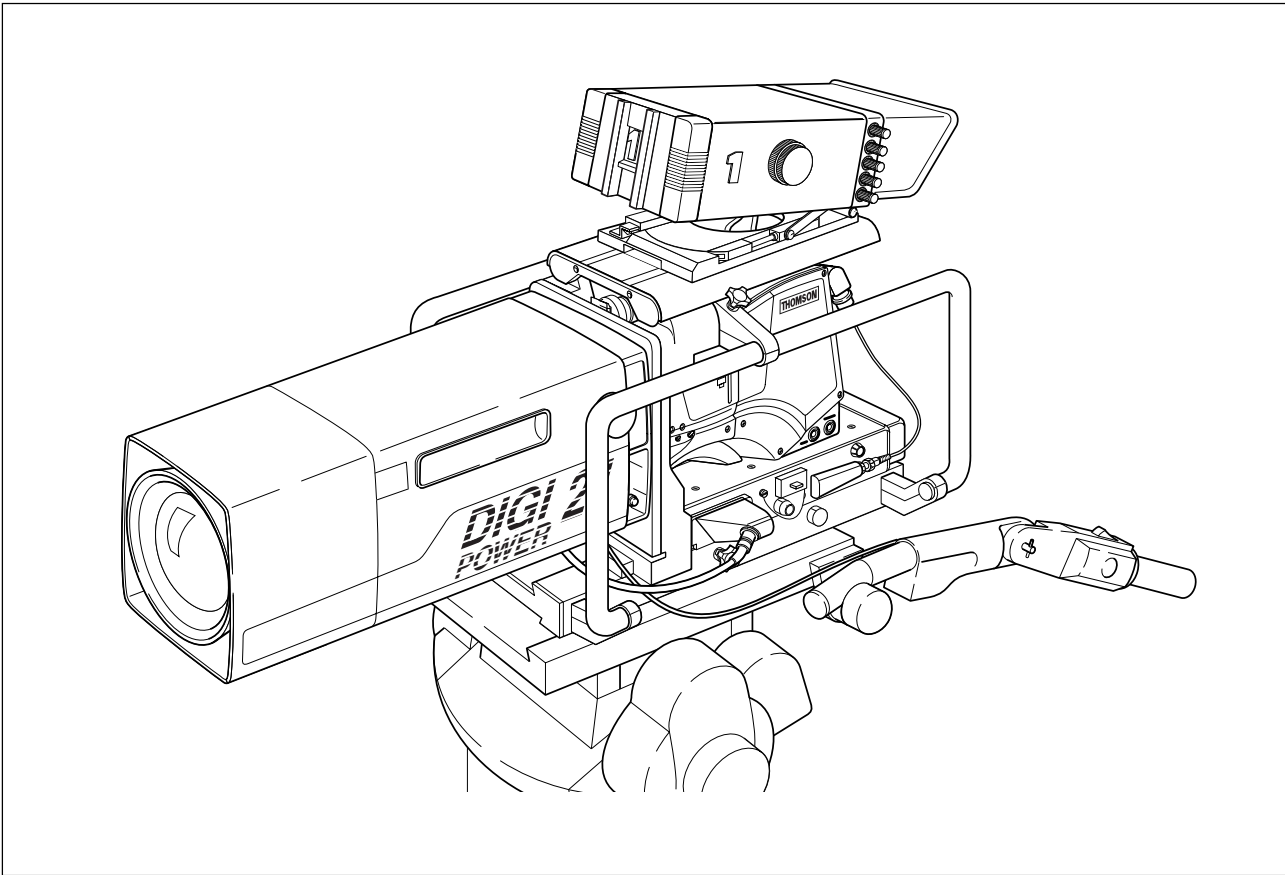

The optional SuperXPander (LDK 4482) for the LDK 100 extends the camera's use in studio and EFP situations. This adapter allows larger studio lenses and a 7-inch viewfinder to be used with the camera. Additional facilities provided include a utility power outlet and a rear control panel.

Refer to the User's Guide of the SuperXPander for more information on mounting the camera and other units to the SuperXPander as well as information on the additional functions of the SuperXPander.

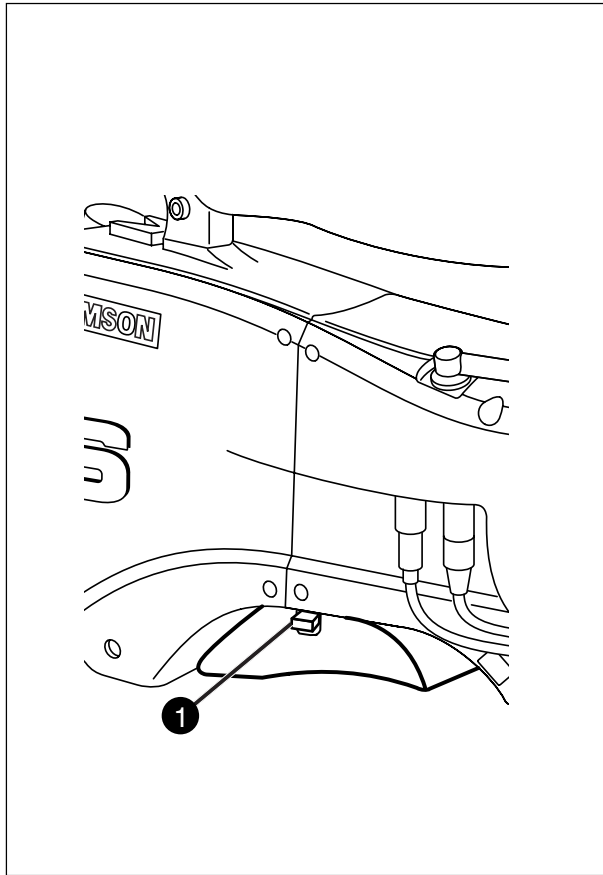

To change the position the shoulder pad press and hold lever ❶. The shoulder pad can now be moved backwards and forwards along the axis of the camera. Adjust the shoulder pad when all units have been mounted so that the best balanced position can be obtained.



The rain and off-use cover must be used when the camera system is in a wet or damp environment. This protection is necessary for personal safety reasons. The cover can also be used indoors to protect the camera when it is used in dusty environments. It can also be useful if the camera is being put into storage. For more information on how to put on the cover refer to the User's Guide which is supplied with it.

Note:

When the camera is used with the SuperXPander LDK 4482 an optional rain and off-use cover (LDK 6989/00) is available.

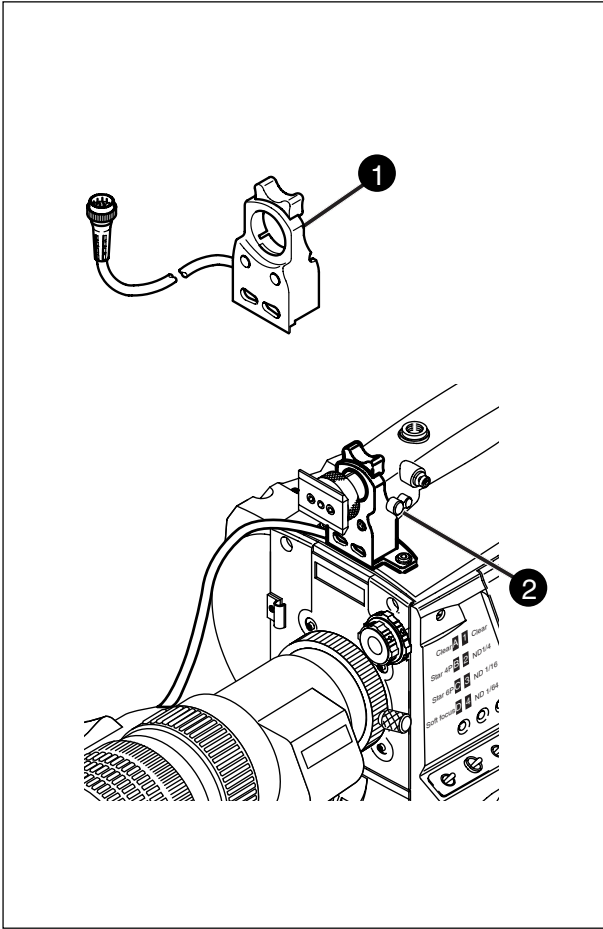

An optional zoom control unit ① can be mounted on the carrying handle. The three available versions for different types of lens are:

- LDK 6113 / 16 for Fujinon.
- LDK 6113 / 26 for Canon.
- LDK 6113 / 36 for Angenieux.

This control unit not only controls the zoom but also has mini-button controls for the VTR start/stop function and the VTR Ret. function. These are located under the front of the carrying handle ②.

The instructions for mounting the zoom control unit and the function of the controls are supplied with the unit.

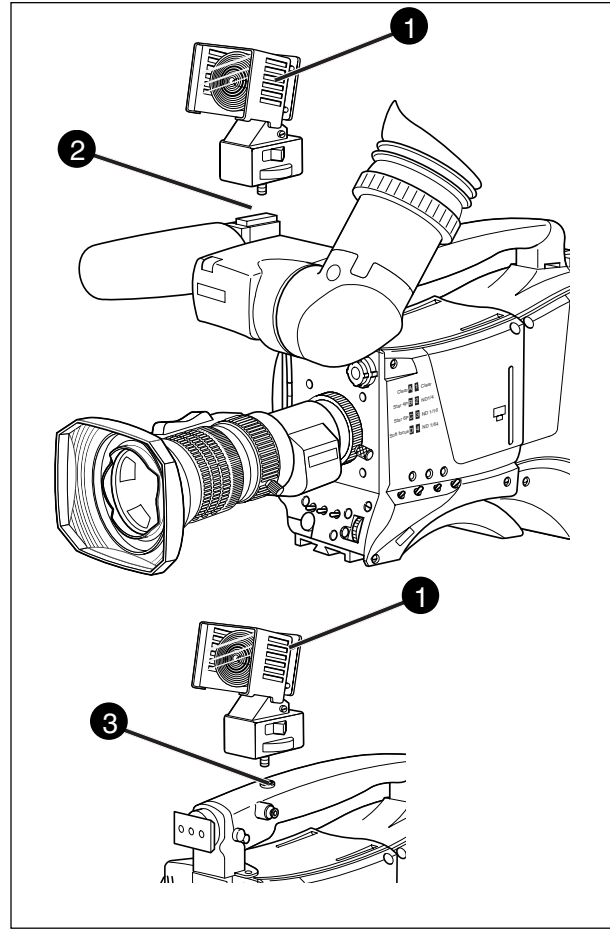

To mount a top light ① onto the camera, proceed as follows:

- a. Screw the top light ① into either the WW1/4"-20 screw hole ② located on the carrying handle or the screw hole ③ on the top of the microphone holder.
- b. Power the top light according to the instructions delivered with the light.

Section 3

Configurations

The LDK 200 is a multi-role camera head and this section describes how it can be used on location or in a studio environment. Information is also provided on the main video and audio signal paths through the camera head.

Contents

Basic Configurations	3-2
----------------------------	-----

Basic Configurations

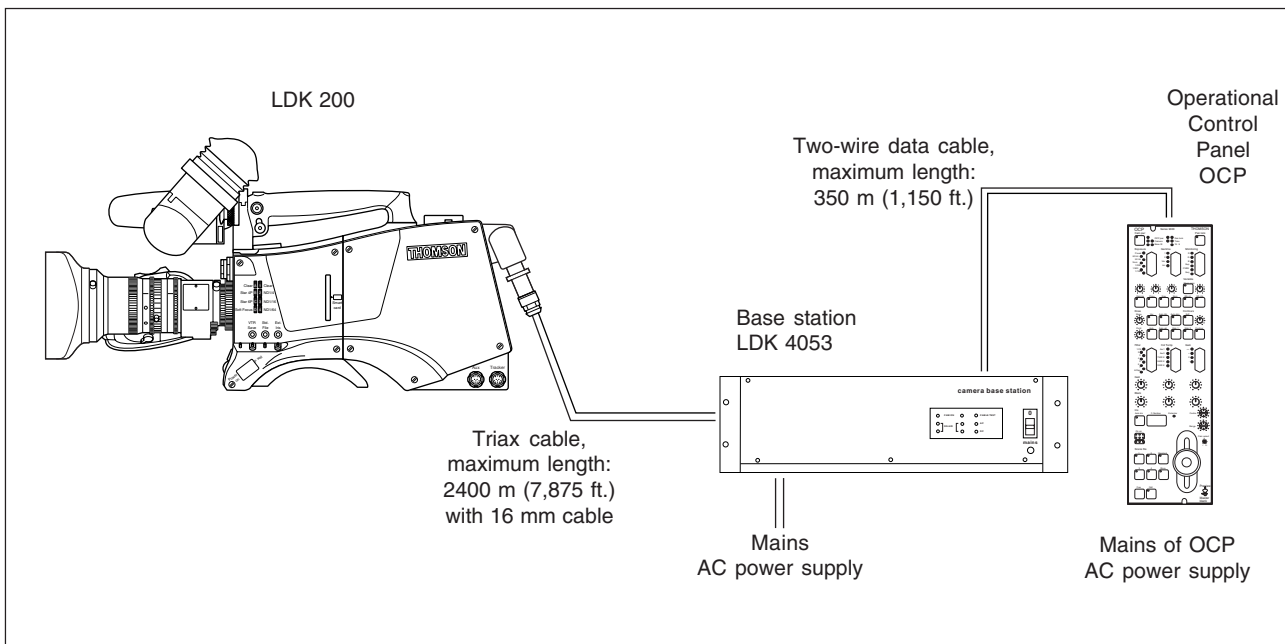

In this mode the camera is connected to a base station via a Triax adapter and cable. Remote control of the camera is achieved by a remote control panel of the Series 9000 Control System. This can be an operational

control panel (OCP) connected to the base station. The data communication between camera and base station is carried over the Triax cable.

Section 4

Location of Controls and Functions

This section shows the physical location of the controls and connectors on the camera. These are grouped according to their function so as to provide a quick reference guide to the operation of a particular aspect of the camera.

Contents

Power Supply	4-2	Video Functions	4-4
Security and Access	4-2	Viewfinder	4-7
Audio	4-3	Viewfinder Indicators	4-8
Intercom	4-3	Control Functions	4-9

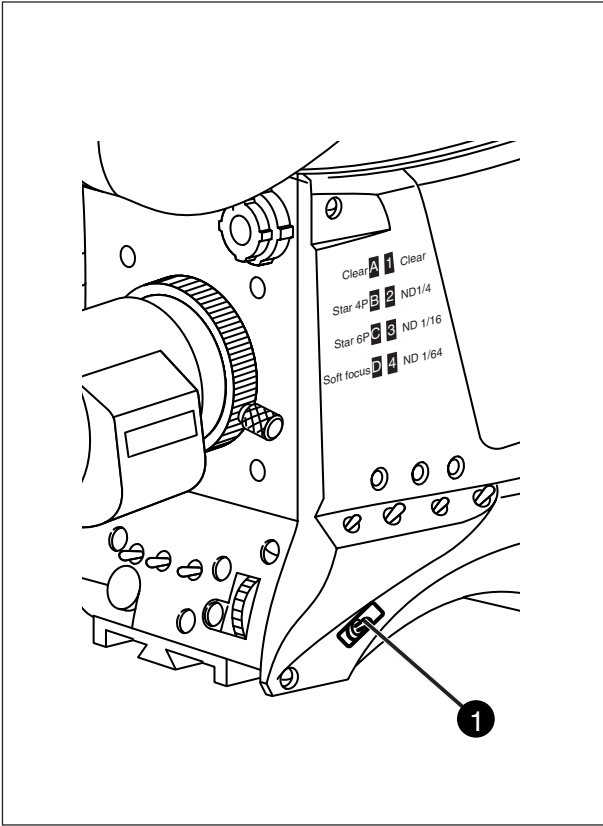

1 Power switch

The power switch has two positions:

On: Power to camera is switched on.

Off: Power to camera is switched off.

When you switch off the power, the access rights that were obtained by the use of the PIN code are disabled and the camera starts at the assigned user level when switched on again.

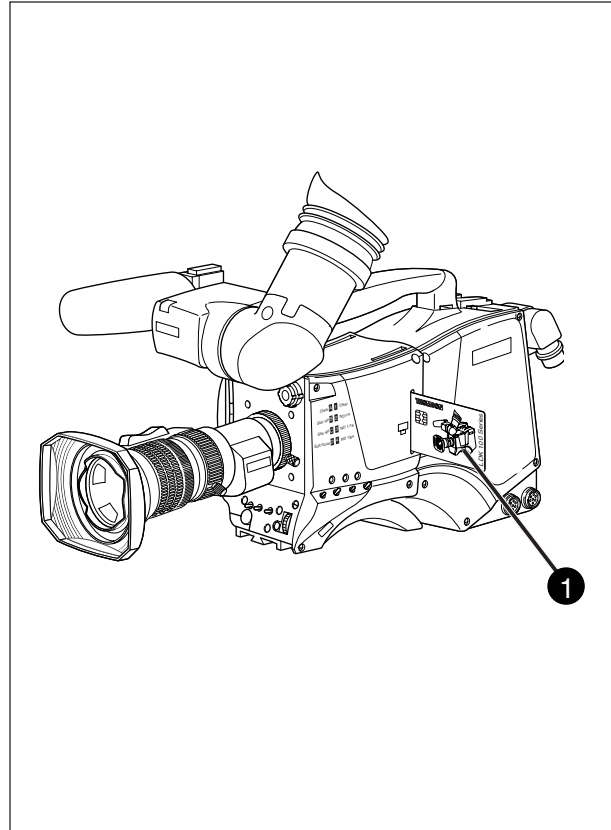

1 Smart card slot

Insert your smart card into this slot with the chip on the card facing the front of the camera. Push the card home until it fits snugly.

There are two types of card; an owner card and a user card. Both cards store operator files and scene files.

The owner card can be used to change the user level of the camera. The user level determines which set of controls and functions can be changed by the camera operator. Refer to Section 6 for more information on the smart card.

A smart card is not required for normal operation of the camera.

Note

Only use an original Thomson camera card.
Store the owner card in a safe place.

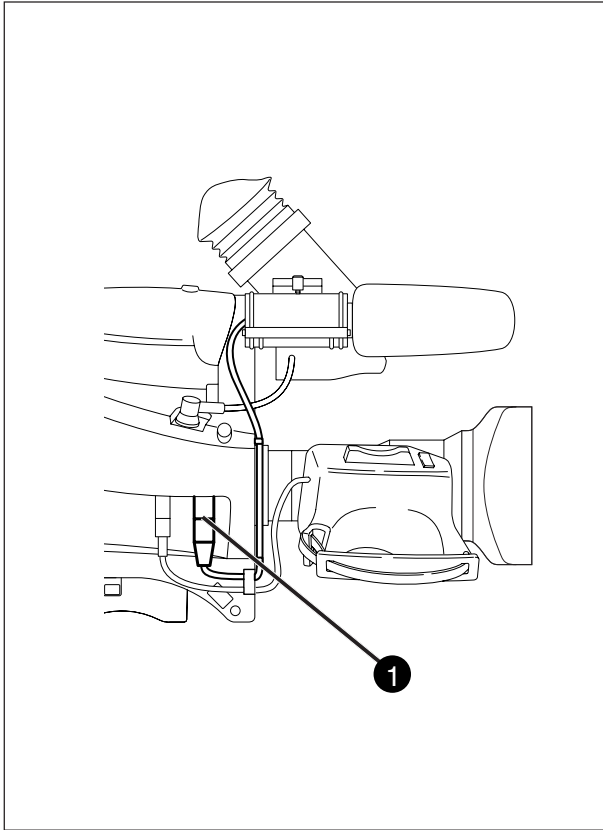

1 Audio microphone connector front

Balanced input connector for a high quality microphone. A phantom power supply (48V) for the microphone is provided from this socket. The gain of this audio channel can also be controlled.

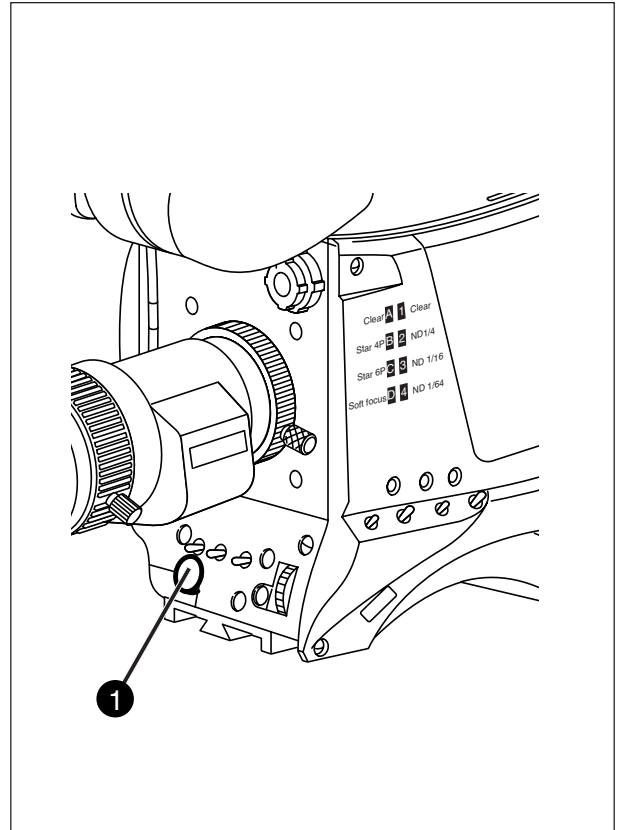

1 Headset Production volume control

This control varies the volume of the production intercom signal to the camera operator's headset.

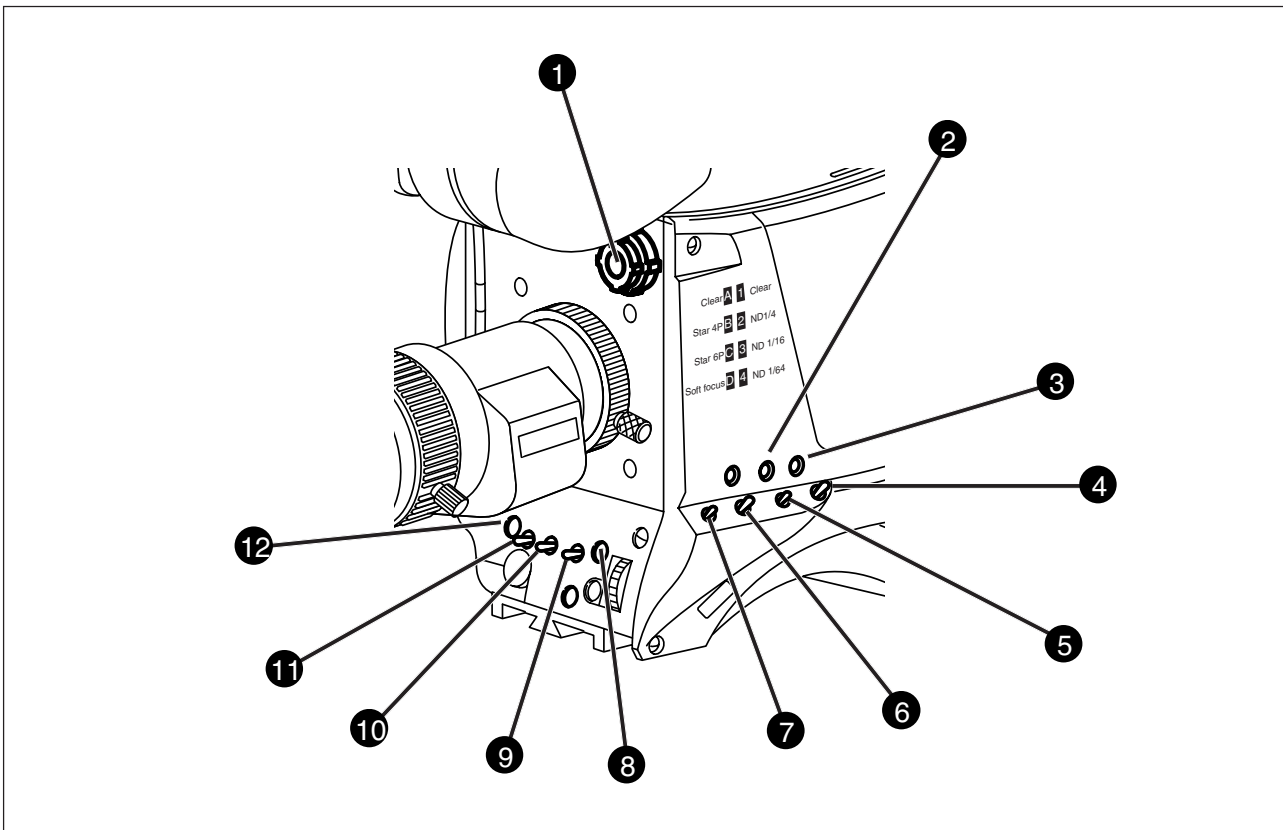

1 Filter switches

Rotate these two switches to move the optical filter wheels.

The outer (bigger) filter switch has four positions:

- 1 : Clear
- 2 : ND 1/4 filter (2 stops)
- 3 : ND 1/16 filter (4 stops)
- 4 : ND 1/64 filter (6 stops)

The inner (smaller) filter switch has four positions:

- 1 : Clear
- 2 : 4-point star
- 3 : 6-point star
- 4 : Soft focus

The status of the filter wheels is displayed in the viewfinder for a few seconds.

The ND/RE indicator in the 1.5-inch viewfinder lights when an ND (Neutral Density) filter is selected.

Note:

No optical colour filters are needed with this camera as the colour balance range is sufficient to measure temperatures from 2.5K to 20K.

2 Extended Iris button

When this button is pressed once the current value of the automatic extended iris function. Press the button twice in quick succession to switch between on and off.

This function automatically regulates the video signal level by adjusting the iris opening, the gain level and the exposure time to suit the ambient lighting conditions. When extended iris is on, the non-standard indicator (!) in the 1.5-inch viewfinder lights, and gain and exposure controls are blocked.

③ Std Scene File button

The standard scene file button is a momentary button which, when pressed for two seconds, recalls the standard scene file video values. These values do not take effect immediately if the camera is on air; they take effect when the camera goes off air.

Refer to the Appendix for the default values of the factory defined standard scene file. Refer to Section 6 to find out how to define and assign a standard customer scene file.

If the optional Smart-Touch™ feature is installed and switched on, pressing the Std button for two seconds displays a list of files in the viewfinder menu. Files are listed under the Lighting, Creative, and Matching categories. The standard settings file is also available. Use the Rotary control and Select switch at the camera front to recall a file.

④ Black Stretch switch

This switch when set to the On position, starts the black stretch function. This function gives more detail in the dark areas of the picture. Set the switch to Off to switch off the function. When black stretch is switched on the non-standard indicator (!) in the viewfinder lights.

⑤ Colour Temperature selector (White Bal.)

This up/down scroll selection switch allows a choice between three preset colour temperatures:

- 3200K (3.2K) - for studio lighting conditions
- 5600K (5.6K) - for outdoors, clouded conditions
- 7500K (7.5K) - for outdoors, clear blue skies

three memory positions:

- FL- memory position for fluorescent light
- AW1 - memory position 1
- AW2 - memory position 2

and an automatic continuous white position:

- AWC - continuous measurement (2.5K to 20K)

The memory positions can be filled with measured values using the automatic white balance switch at the front. Indicators in the 1.5-inch viewfinder light to show which position is selected. None of these indicators light when AWC is selected, but the non-standard indicator (!) lights.

⑥ Colour Bars switch (Bars)

The Bars switch turns the colour bar test signal on and off. The lens iris closes automatically when the colour bars are switched on.

⑦ Gain selection switch

This up/down scroll selection switch gives a choice of five master gain settings. The values for these settings, except 0 dB, can be set in the Install menu of the camera systems menu (refer to Section 6). The indicators in the 1.5-inch viewfinder light as follows:

-	Gain is - (-6, -3dB)
+	Gain is + (+6, +9, +12, +18dB)
++	Gain is ++ (+9, +12,+18, +24dB)
+ and ++	Gain is +++ (+30, +36dB)

Note

Reduce crispness (peaking) in the viewfinder when using the +++ position.

⑧ Clean Scan button

When shooting computer monitors with higher frame frequencies than the camera use the Clean Scan function to avoid horizontal bars in the picture.

Press the Clean Scan button for two seconds to directly access the variable exposure (clean scan) function. Use the rotary control to change the value and so remove the noise bar. When you are finished shooting the monitor press the Clean Scan button for two seconds to switch off the Clean Scan function.

When the Clean Scan function is on, the non-standard indicator in the viewfinder lights. Refer to Section 5 for more information on shooting screens.

⑨ White Balance switch

This momentary switch is used to start the automatic white balance process. The camera, when pointed at a white area in the centre of the picture, measures and stores a colour temperature setting in the FL, AW1 or AW2 memory position.

The white balance switch only operates if the colour temperature is set to the FL, AW1 or AW2 position. Refer to Section 5 for more information on how to use the automatic white balance.

Note

Black balance is not necessary with this camera because of the continuous automatic black control circuits.

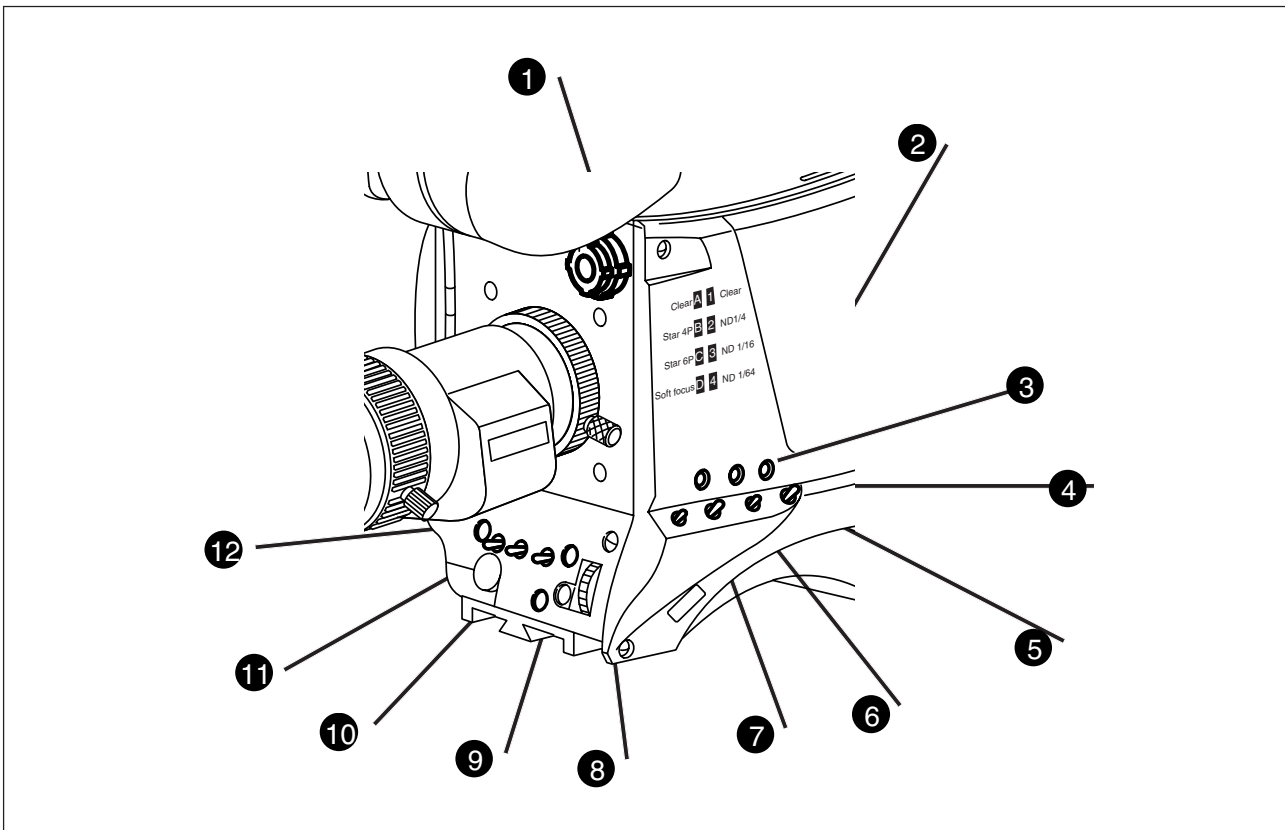

10 Exposure Time switch

This up/down momentary switch gives a choice of eight exposure time settings. These are:

- Nom. - nominal setting
- Var. - enables the exposure to be varied
- Crt - for shooting sync-locked monitors
- Film - enables the exposure to be varied with running shutter.
- 1/200 - for fast moving objects
- 1/500 - for fast moving objects
- 1/1000 - for fast moving objects
- 50 Hz - shooting with 50Hz lighting (adjustable)
- 60 Hz - shooting with 60Hz lighting (adjustable)

If an exposure time other than nominal is selected, the non-standard indicator (!) in the viewfinder lights

11 Vertical Shift switch (V-Shift)

Sometimes when shooting TV screens or monitors with the same display frequency as the camera, a horizontal black bar is seen in the viewfinder because the camera is blanking while the TV is not. The V-Shift switch shifts the camera blanking. It is spring-loaded with a central rest position. Holding the switch in the + or - position moves the bar up or down so that it is no longer visible in the viewfinder. This function is only available when the camera is used in the stand-alone mode and is not active when the camera is genlocked or on-air.

12 VTR Start button

In the triax mode this button switches the intercom microphone of the headset to the production intercom channel. This button operates in parallel with the VTR button on the lens.

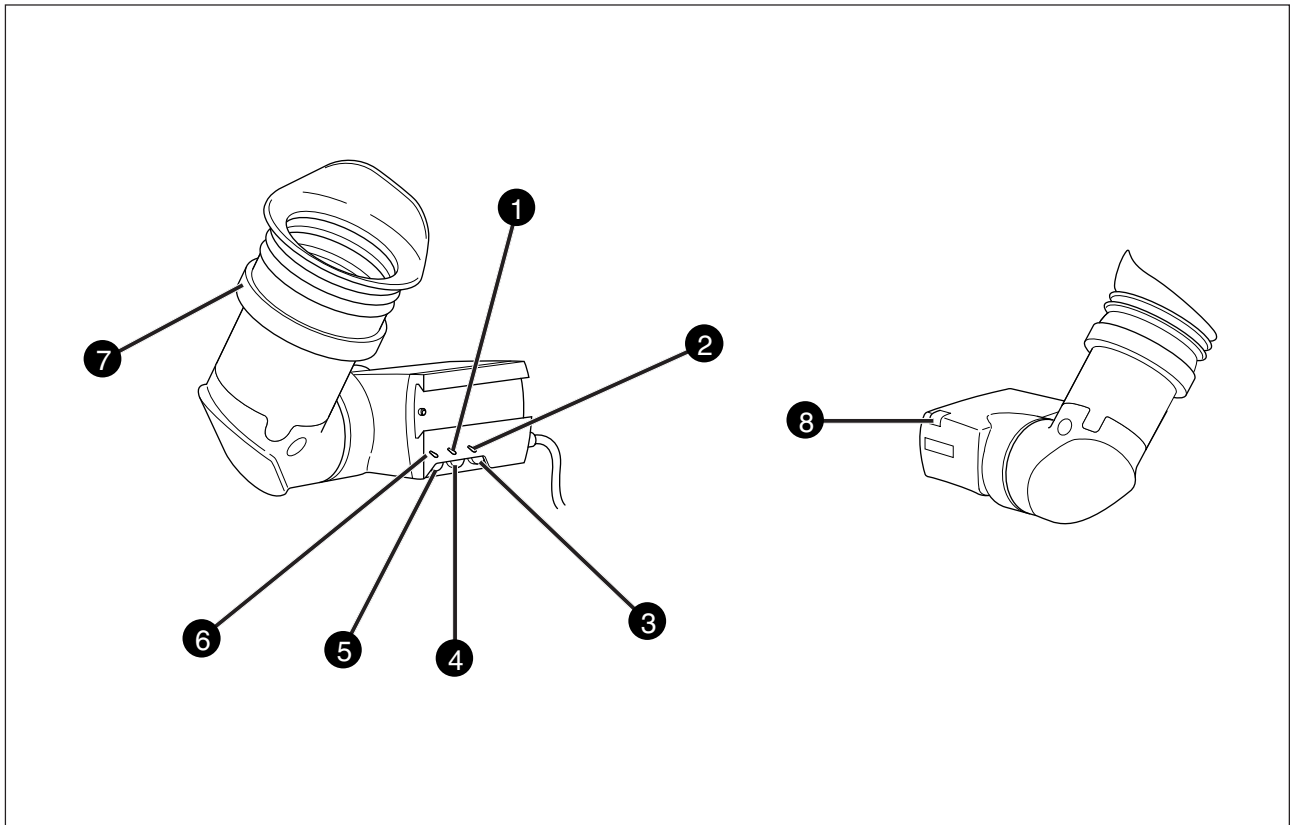

1 Zebra switch

This switch disables (OFF position) or enables the zebra pattern in the viewfinder which indicates high video levels. Values for the zebra function are selected in the VF menu. (The zebra pattern is switched off when the skin view is on.)

2 Option switch

This switch is included on the viewfinder to allow future features to be incorporated.

3 Brightness control

Use this rotary control to adjust the brightness of the viewfinder display to suit your needs.

4 Contrast control

Use this rotary control to adjust the contrast of the viewfinder display to suit your needs.

5 Crispening control

This rotary control adjusts the sharpness of the picture displayed in the viewfinder. Reduce the crispening for a better picture when the gain is set to +++.

6 Tally switch

The tally switch is used to control the tally indicator at the front of the viewfinder.

When this switch is set to the ON position, the tally indicator light when the camera is on-air.

When this switch is set to the OFF position, the tally indicator does not light when the camera is on-air.

The tally switch does not control the tally indicator at the rear of the carrying handle.

7 Dioptre

The dioptre of the viewfinder can be adjusted to suit your eyesight by turning the dioptre ring. The range of the dioptre is +1 to -3.

8 Tally indicators (red)

The red tally indicators at the front of the viewfinder and at the rear of the carrying handle light to indicate that the camera is on-air. The tally indicator at the front of the viewfinder does not light when the camera is on-air if the tally switch is set to the OFF position.

Viewfinder Indicators

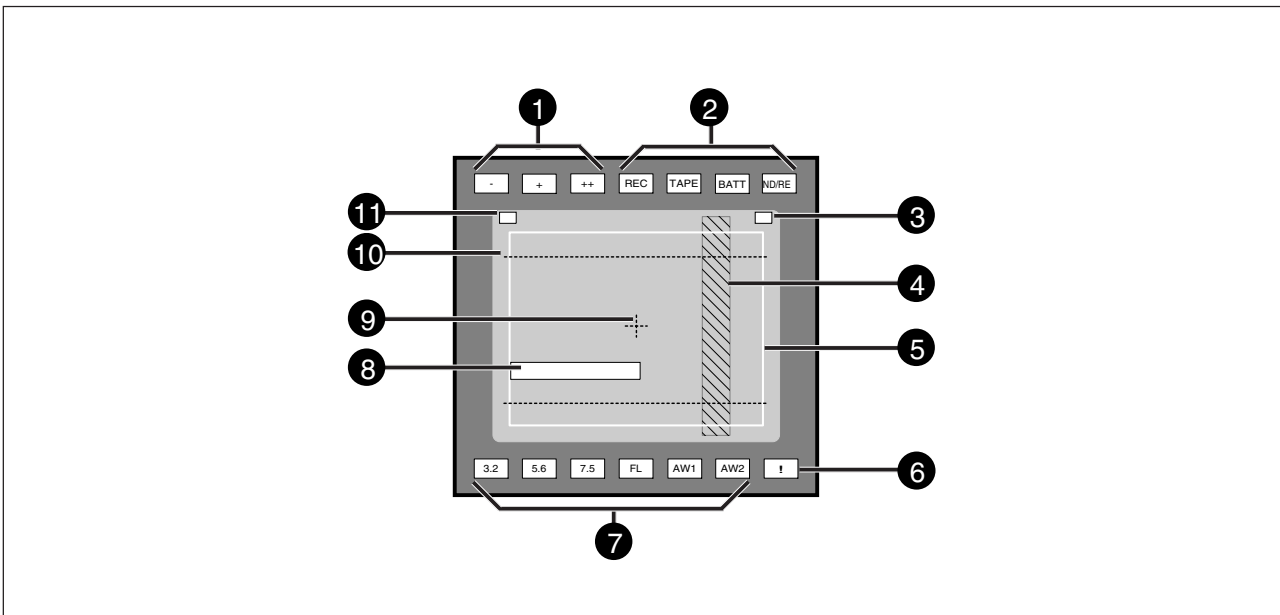

1 Gain indicators

The gain indicators in the viewfinder light as follows:

- Gain is - (-3 or -6dB)
- + Gain is + (+6, +9, +12 or +18dB)
- ++ Gain is ++ (+9, +12, +18 or +24dB)
- + and ++ Gain is +++ (+30 or +36dB)

2 Top indicators

- REC** lights when the camera is on-air.
- TAPE** lights when the studio ISO signal is received.
- BATT** lights if the supply voltage is less than 11V.
- ND/RE** lights when an ND optical filter or the lens range extender is selected.

3 Iris indication

Indicates the value of the iris opening (when enabled in the VF menu).

4 Zebra pattern

This diagonal line pattern warns the operator that the area affected has risen above a predetermined level of the full scale video exposure value. Level and contrast are selected in the VF menu.

5 Safe area marker

The safe area marker indicates an area that represents 80% of the whole viewfinder picture area. This is the minimum area seen on a TV-set.

6 Non standard indicator

The non-standard video settings indicator (!) lights when exposure is not set to nominal. It also lights when black stretch or extended iris is on and if AWC or FL is selected with the Colour Temperature selector.

7 White Balance indicators

The white balance indicators light as follows:

- 3,2** - preset temperature of 3200K is selected
- 5,6** - preset temperature of 5600K is selected
- 7,5** - preset temperature of 7500K is selected
- FL** - memory for fluorescent light is selected
- AW1** - memory 1 is selected
- AW2** - memory 2 is selected

None of these indicators light if AWC is selected.

8 Message box

The display time of this information message box is set by the Info time item of the VF menu.

9 Centre marker

This cross marks the centre of the picture.

10 Cadre marker (only switchable cameras)

These dotted white lines show the limits of a 4:3 picture in the 16:9 mode, or the limits of a 16:9 picture in the 4:3 mode.

11 Zoom indication

Indicates the degree to which the lens has been zoomed in or out if this feature is supported by the lens. It shows 50 if not supported.

Control Functions

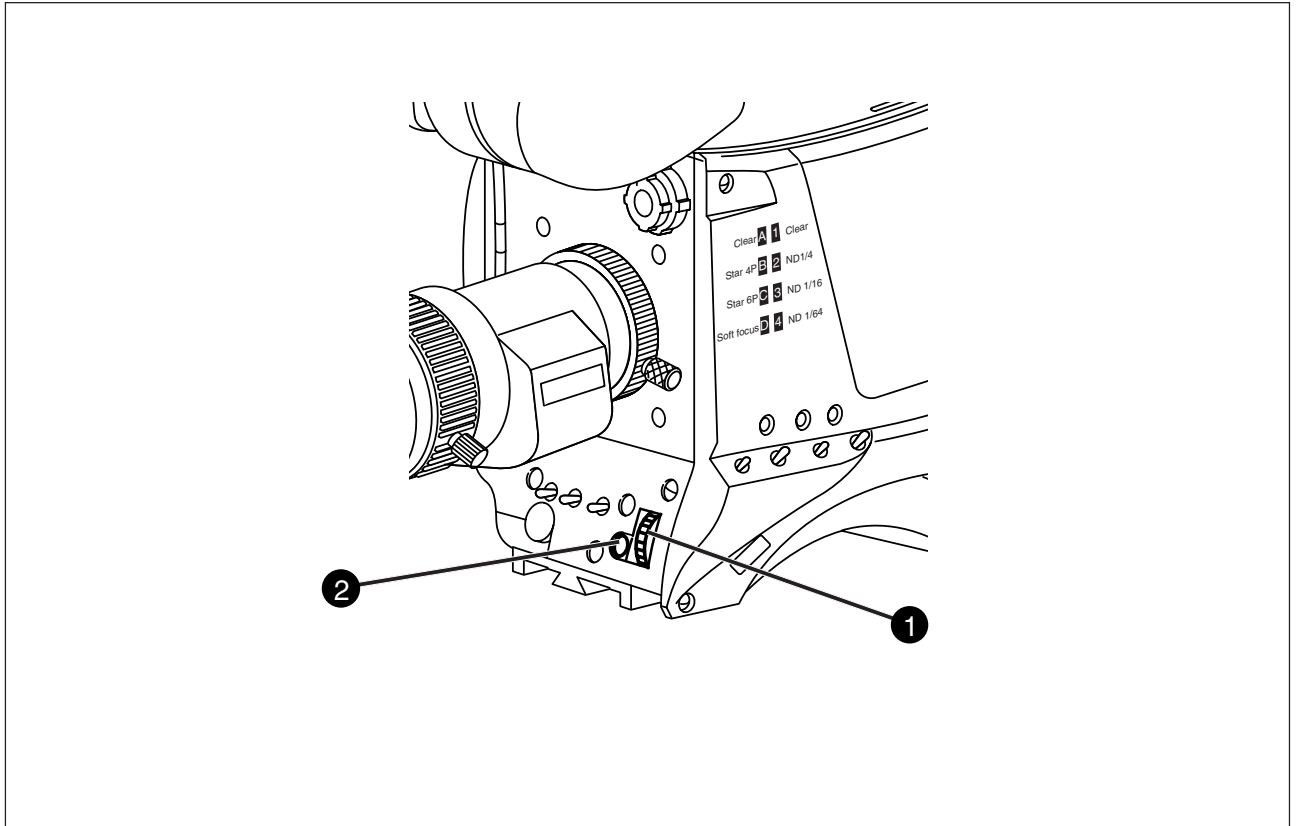

The system menus are displayed in the viewfinder. There are two controls at the front of the camera that allow you to navigate through these menus.

The functions handled by the system menus are divided into eight different menus that are listed in the main menu as follows:

VF	>>
Lens	>>
Video	>>
Install	>>
Files	>>
Security	>>
Diagnostics	>>
Service	>>

(Some of these items may not appear if the user level is not set to 3.)

Each of these menus gives you access to a particular group of functions.

❶ System Menu Rotary control

This rotary control is used to move through the various menus of the control system. It is also used to vary the value of some functions.

❷ System Menu Select switch

This switch, when pressed, selects the particular menu that is pointed out by the cursor in the viewfinder menu display. It is also used to set an on/off function or to select a value from a list.

More information on using the system menus is contained in Section 6.

Section 5

Shooting

This section contains information on the practical use of the camera using the viewfinder display and the switches at the front to control the camera.

Contents

Using the Camera	5-2	Colour temperature selection	5-5
Standard settings	5-3	Auto-White Balance	5-5
Colour Bar	5-4	Shooting Screens	5-6
Gain selection	5-4	Exposure Time	5-6
Optical filter selection	5-4		

Using the Camera

The camera is operated via the viewfinder text display and the control system switches on the front panel. You have great detail and selection at your disposal when changing all the functions that are available in the camera. Refer to Section 6 - Operating the Menu System - for an explanation of the use of the menu selection structure and the viewfinder text display.

This section describes the operational functions that are available when using the camera via the viewfinder display and the switches at the front. These offer a convenient way of accessing the menu system which provides full control of the camera.

There are a number of steps that must be carried out before satisfactory shots can be obtained:

- a. The camera must be set up and powered.
- b. The standard settings must be recalled.
- c. Adjustments must be made for ambient lighting.

Physical set-up and power supply

Attach lens, viewfinder, microphone and any other accessories to the camera as described in Section 2 - Assembling the Units.

Connect the triax cable to the triax connector and the camera operator's headset to the headset socket on the rear panel of the camera. Connect the audio microphone to either the audio socket on the right side of the camera or the socket on the rear. The camera is powered by the base station via the triax cable. Set the power switch on the left side of the camera to the on position.

Operator preferences

With the owner card or the PIN code set the user level. The recommended minimum user level is 1. Setting the camcorder to level 0 is too restrictive for normal circumstances. For full control set the level to 3.

Viewfinder preferences

Set up the viewfinder according to your own preferences; select markers, message boxes and on-screen display times.

Lens preferences

Set up the lens according to the manufacturer's instructions. Select the lens type from two predefined settings; standard or wide angle. Choose and, if necessary, adjust the iris parameters to suit the lens and your personal preferences.

Video preferences

The camera is now ready for use, however, the ambient conditions must now be taken into account and the appropriate adjustments made on the camera:

- a. Recall the standards settings.
- b. Switch off the colour bar (when on).
- c. Select the gain.
- d. Select a neutral density optical filter if required.
- e. Set a preset colour temperature or carry out the automatic white balance procedure.
- f. Select the correct exposure time.

Note:

The number of functions available depends on the user level that has been set. Refer to Section 6 for more information on setting the user level.

Standard settings

To ensure that some of the camera functions are not set to unusual values, a standard file has been defined that contains the default values for most video functions. The table in the Appendix lists the values that are set when the standard file is recalled.

Press the green STD button on the left side panel of the camera and hold it for 2 seconds to recall the standard values for the various video functions. The standard values only take effect when the camera is not on-air.

Note:

The standard file can be selected as either a factory or a customer standard file. Changing the standard file can only be done in the System security menu if the owner card or the PIN code is used.

Smart-Touch™

Smart-Touch™ is an optional software module that gives immediate access to 14 pre-defined scene files. This library allows you to quickly set up the camera for different shooting conditions. To choose a particular file proceed as follows:

- a. Press the green STD button for 2 seconds; the viewfinder shows the library of available shooting conditions.
- b. Select a file by rotating the selection wheel at the front of the camera.
- c. Activate the file of your choice by pressing the Select button at the front of the camera.

The new values only take effect when the camera is not on-air. The Smart-Touch™ files can also be selected by navigating to the Files menu using the System Menu.

The files of the Smart-Touch™ library are divided into three categories, Lighting, Creative, and Matching, which complement the standard setting scene file.

The Lighting category provides three different files for various lighting conditions:

- **Night** optimises the transfer characteristic to enhance the visibility of detail in very dark scenes without the undesirable consequence of excessive noise associated with simply increasing gain.
- **Fluorescent** establishes matrix and colourmetric parameters to reduce the green tinge and give a more acceptable picture when the scene is lit with uncorrected fluorescent lighting.
- **Extreme contrast** uses the full dynamic range of the FT CCD sensor to obtain better handling of highlights and more detail in the shadows.

The Creative category provides seven files for different effects:

- **Sports warm colour** delivers warm and rich contrasts bringing out team colours.
- **Sports interview** incorporates the dual skin tone control into the sports setting for interviews.
- **HI film** gives a high contrast film-like look which is ideal for outdoor location production.
- **HI film + skin** is the HI film setting with dual skin tone control incorporated for natural, flattering close-ups.
- **LO film** gives a low contrast film-like look for studio production.
- **LO film + skin** is the LO film setting with dual skin tone control incorporated for natural, flattering close-ups.
- **Sepia** creates a sepia tone look for atmosphere-rich production.

The Matching category provides three files for camera matching:

- **LDK 9x + LDK 10** for matching to Philips LDK 9, LDK 10, LDK 90 and LDK 91 cameras.
- **DVW xxx** for matching to Sony camcorders.
- **HL xxx** for matching to Ikegami camcorders.

Each of these settings can be personalised and stored on a smart card.

The left side panel also contains a button for switching on the colour bar test signal. The colour bar is a standard test signal which is used to set up and check the camera before use.

When the colour bar is selected the following functions are temporarily set to the values listed below:

Black stretch	:	Off
White limiter	:	Off
Zebra	:	Off
Safe area (VF)	:	Off
Cadre (VF)	:	Off

A neutral density filter and a special effect filter can be placed in the path of the optical signal to modify the incoming light. The filters are selected via the filter switches at the top-front of the camera. These filters can be used, for example, to control depth of field.

The LDK 200 does not need colour optical filters to be able to white balance correctly. The range of the auto-white balance is so wide (from 2.5K to 20K) that there is never any need to use colour filters to obtain the correct white.

Gain selection

Depending on the available light levels it may be necessary to adjust the gain of the camera. The gain is selected via the Gain up/down switch on the left side panel. When this switch is pressed initially, the current value of the gain in dB is displayed in the viewfinder.

A new value is chosen by scrolling up or down through the five preset values (-, 0, +, ++ and +++). The actual dB value of these gain steps can be set in the install menu.

The -, + and ++ indicators at the top of the 1.5-inch viewfinder show which preset is selected.

Colour temperature selection — Auto-White Balance

For true colour reproduction the ambient lighting conditions must be compensated for by selecting a value for the colour temperature. The standard file setting is 3200K (normally used for tungsten light). Two other reference colour temperatures are available; 5600K (for outdoors, clouded conditions) and 7500K (for outdoors, clear blue skies).

Three similar memory positions (FL, AW1 and AW2) are available to store the results of the auto-white measurement process. The FL position is recommended for shooting with fluorescent light.

A continuous automatic white balance position (AWC) is also available. This function continuously measures the white balance and adjusts accordingly. It can be used when a constant colour balance is required under changing lighting temperatures (sunsets, indoors/outdoors use). When AWC is selected none of the colour temperature indicators in the 1.5-inch viewfinder light.

The colour temperature is selected via the up/down scroll switch (White Bal.) at the left-front side of the camera. The viewfinder displays the current value. A new value is chosen by scrolling up or down through the available values. The colour temperatures are shown in the following order:

- White balance : 3200K
- White balance : 5600K
- White balance : 7500K
- White balance : FL
- White balance : AW1
- White balance : AW2
- White balance : AWC

The viewfinder displays the selected value and the actual measured colour temperature. The range of the auto-white balance is from 2.5K to 20K.

In the auto-white positions an electronic colour filter can be adjusted in the system Video menu. This varies the colour balance to obtain warmer or colder colour effects. When an automatic white balance process is performed, the electronic colour filter is reset to its default value.

If the reference colour temperatures do not match your lighting conditions carry out the auto-white procedure as follows:

- a. Use the colour temperature switch to select one of the memory positions FL, AW1 or AW2 in which to store the measured colour temperature value.
- b. Press once on the white balance switch at the front of the camera to start the automatic white balance procedure. The following appears in the viewfinder:

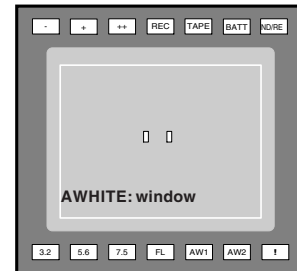

- c. Point the camera so that the reference white surface is between the two small white boxes.
- d. Press the white balance button again to start the measurement procedure. A message indicating that the process is running appears.

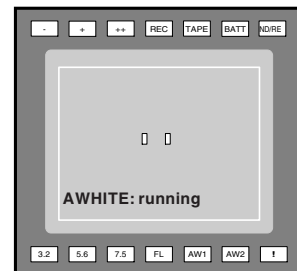

- e. When the process is completed (within a few seconds) the OK message and the measured temperature appear in the viewfinder.

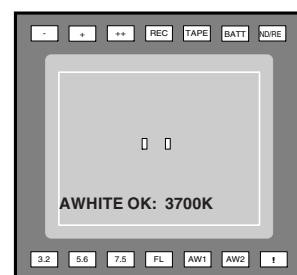

The measured colour temperature is now stored in the selected memory position and can be recalled as required. The camera is now ready for use.

Note:

During the auto-white measurement process iris is set to Auto and 90% and the knee is turned off.

Sometimes when shooting TVs or computer monitors a horizontal bar can be seen across those screens in the viewfinder. There are two ways of removing the noise bar from the picture depending on the frame frequency of the display. For displays with the same frame frequency as the camera, for example TV sets, use the V-shift facility. For displays with a higher frame frequency, for example computer monitors, use the Clean Scan facility.

Clean Scan

To use the Clean Scan function press the Clean Scan button at the front of the camcorder for about two seconds to directly access the variable exposure (clean scan) function. Use the rotary control to change the value and so remove the bar.

The ranges are:

from 50.6 to 103.1 for PAL cameras

from 61.1 to 151 for NTSC cameras

When you are finished shooting the monitor press the Clean Scan button for two seconds to switch off the Clean Scan function. (Exposure Time returns to its previous non-variable setting.)

Note:

Do not shoot highlights in the clean scan mode as this may cause a smear effect.

V-SHIFT

The vertical shift switch (V-SHIFT) at the front of the camera is used for displays with the same frame frequency as the camera, for example TV sets. It is an up/down type switch. Pressing the switch moves the black bar up or down so that it is no longer visible in the viewfinder. This function is only available when the camera is used stand alone and is not active when the camera is genlocked or on-air.

If the frame frequencies of camera and monitor are different use the clean scan of the variable shutter function.

CRT Exposure

A third possibility can arise when shooting a monitor whose synchronisation is locked to the camera's. Stripes might be visible in the picture of the monitor. (This is more usual with 16:9 cameras.) To remove these disturbing line pairing effects between monitor and camera lines, select the CRT option with the Exposure time switch.

The exposure time values of 1/200, 1/500 and 1/1000 of a second are used to capture fast moving objects so that these can be played back sharply in slow motion. The value selected depends on the speed of the moving object.

Note:

Increasing the exposure speed lowers the camera sensitivity proportionally.

The exposure selection also includes lighting control positions which can be used when shooting with lighting that is operating at a different frequency to the camera. There are two position 50 Hz and 60 Hz. Each of these positions can be varied further in a range from -10 to +10.

To reduce flicker select the frequency closest to the frequency of the lights and then vary the lighting control in the system Install menu to obtain the best result.

Film

The Film function is a variable exposure function with running shutter. The Clean scan range is wider but with the Film function highlights will not cause a smear effect. If the Film function is selected the exposure time can be set in the Viewfinder menu.

Section 6

Using the Menu System

Because the LDK 200 offers such a wide range of functions, this section describes the structure of the control system. It contains procedures for controlling the menu system and explains how to program the menu system for your personal preferences. The menu structure and the methods of function selection are also explained.

Contents

Introduction	6-2	Systems Menu	6-3
--------------------	-----	--------------------	-----

Introduction

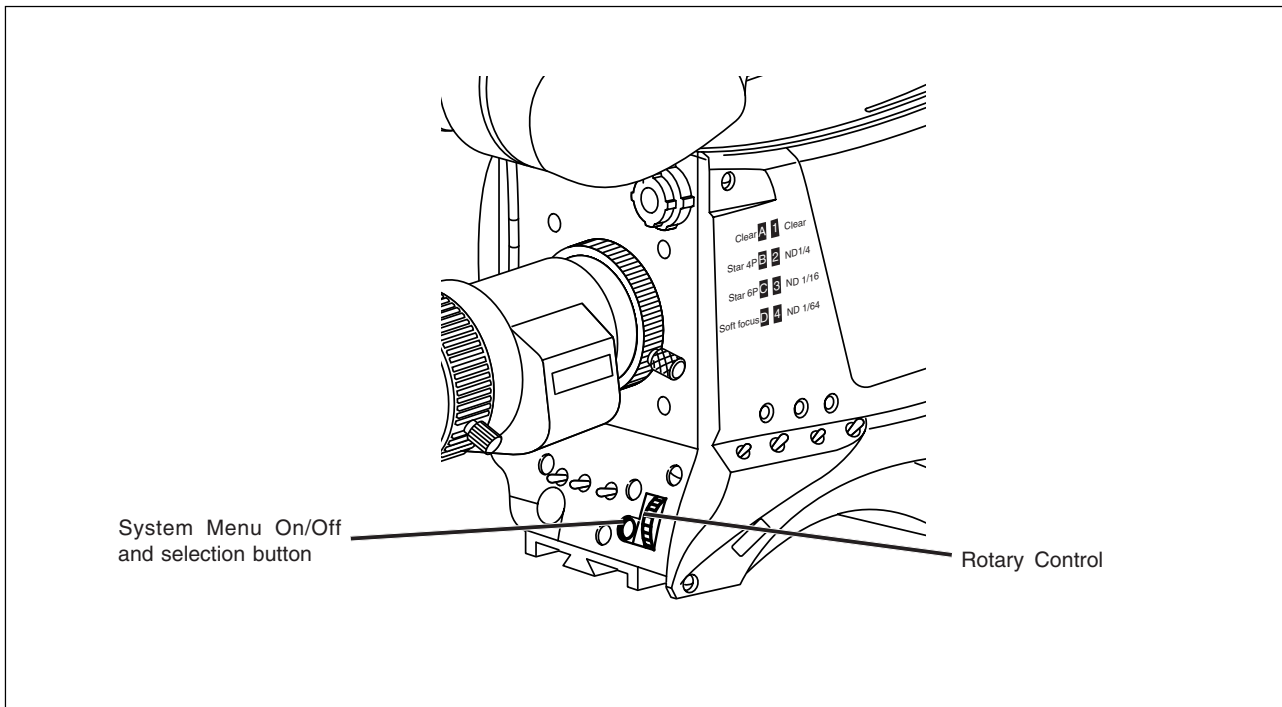

Operationally, the camera is very easy to use. However, because of the large number of functions available and the large number of set-up options, it may require some time for you to become familiar with them all. We recommend that you spend time using the various controls and displays in order to discover the wide range of possibilities.

Read the instructions in this section carefully but also feel free to examine the various menus in detail. In this way you will learn quickly to intuitively operate the camera.

Systems Menu

The system functions of the camera are grouped into menus and sub-menus. The systems menu is viewed in the viewfinder and navigated by means of the Rotary control and the Select button which are both located at the front of the camera.

Entering the Systems menu

Press the Select button after the camera is switched on, the message **Menu off** appears in the viewfinder. Press the Select button again while this text is showing, the MAIN menu appears in the viewfinder.

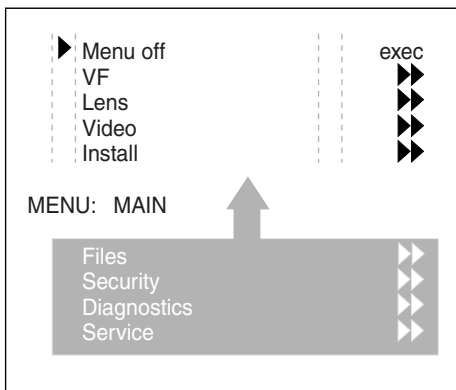

The MAIN menu screen shows five items. The name of the menu is shown below these. Four more items are hidden but become visible when you scroll down using the rotary control.

(Some of these items may not appear if the user level is not set to 3.)

A cursor shows your position in the menu. The Rotary control moves the cursor up and down.

Finding your way

Use the Rotary control to move the cursor through the menu items. If a double arrow (>>) is visible, then pressing the Select button brings you one level lower in the menu system. Only five items are visible in each menu. Scroll up or down to see any additional items.

When you first enter a menu (other than the MAIN menu) the cursor is positioned next to the first item.

The TOP and PREVIOUS entries are not immediately visible but are located above the first item. Use the Rotary control to scroll up to them.

- Select TOP to bring you back to the MAIN menu.
- Select PREVIOUS to go back to the menu that you were in before the current one.

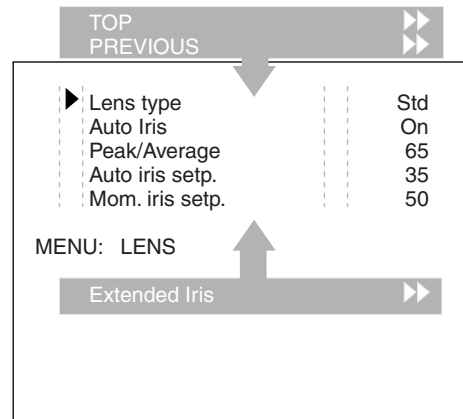

The LENS menu above shows the items displayed when you first enter the menu and the other items that are available by scrolling up or down with the Rotary control.

Leaving the Systems Menu

If you are deep within the menu structure, follow these steps to leave:

- a. If necessary move the cursor to the leftmost column with the Select button.
- b. Scroll upwards with the Rotary control until the cursor points to TOP (this is the MAIN menu).
- c. Press the Select button. The cursor now points to the Menu off item of the MAIN menu.
- d. Press the Select button to leave the System menu.

This is the recommended way of leaving the System menu.

If you do not use the menu it disappears after a few seconds. (This delay can be programmed in the VF menu.) However, when you press the Select button again you enter the System menu at the last position of the cursor and not at the top of MAIN menu.

To prevent confusion the next time you enter the System menu, it is advisable to leave the System menu by returning to the MAIN menu (TOP) and selecting Menu off.

Making changes

To find out where you have to go to change a function, consult the appendix to discover under which menu group or sub-group the function you want to change is located.

If the cursor points to an item (and there are no double arrows to indicate a sub-menu) then the item pointed to has a value. The value can be:

- a toggle value (only two values)
- a list value (more than two values)
- an analogue value (variable from 00 to 99)

or unavailable (---).

If the value is unavailable it cannot be changed. This is indicated by three dashes (---). This can occur, for example, when a function is switched off. The analogue values associated with that function are then unavailable.

If there are only two values associated with the function, then pressing the Select button toggles between these two values.

If a value is displayed next to a function that is one of several possible values, then pressing the Select button places the cursor in a list menu indicating the value currently selected. Use the Rotary control to point to a new value. Press the Select button to return the cursor to the function list.

If an analogue value is displayed next to a function name, then pressing the Select button places the cursor in front of the value and the Rotary control is used to change the analogue value. Press the Select button to return the cursor to the function list.

Undoing changes

If you make changes to the video settings in the Systems menu and you decide not to keep them, use the Std. File button at the side of the camera to recall a standard set of values for the video parameters.

Menu Structure

Access to the functions on these menus is determined by the user level that has been set. The menus are as follows:

Main (top) menu

The top menu gives access to the other menus.

VF menu

This menu contains the functions which determine how items in the viewfinder are displayed.

Lens menu

The functions contained under this menu control various aspects of the lens.

Video menu

The video menu contains those functions which affect the picture quality.

Install menu

This menu contains the functions that are used to set up the general configuration of the camera. It also contains controls to customize those switches that are directly operated on the camera.

Files menu

This menu allows values to be stored in scene and operator files, and allows these files to be recalled as required.

Security menu

The security menu is used by the camera owner to set user levels and to control access to the camera, or to store the customer (scene and operator) default files.

Diagnostic menu

The diagnostic menu is designed to provide information on the current status of the camera.

Service menu

The advanced service menu is available to service engineers for carrying out adjustments and calibrations to the camera (see Technical Manual).

Systems Menu

Security Menu for Owner's Access

The Security menu provides restricted access to special set-up and security features of the camera.

Access to this menu requires the owner's unique smart card for the camera or the PIN code that has been set for the camera.

Note:

An owner card is linked to the serial number of the camera and is unique to that camera. It cannot be used as an owner card for another camera.

Inserting the owner card into the camera gives direct access to the security menu. If you select the Security menu without this card inserted, you must enter the correct PIN code to gain access to the Security menu.

User Levels

The installed user level function in the Security menu restricts access, in varying degrees, to the operational controls of the camera. There are four user levels: user0, user1, user2 and user3.

The purpose of the user levels is to restrict the set of functions which can be changed by whoever is using the camera. In this way a more centralized and uniform control can be achieved and the danger of the camera operator accidentally changing critical functions while shooting is reduced.

User level 0 is a special protection level which locks most of the operational controls of the camera. Use this level to ensure that a camera that has been set-up is not tampered with. User level 0 is not normally used for operational purposes.

Run Hours

This sub-menu allows the date and time to be set and allows the running time of the camera to be viewed for the last 30 days.

PIN Code

The PIN code of the camera can be viewed and changed in the Security menu.

The camera's PIN code when it leaves the factory is set to 0000. It is strongly advised that this code be changed by the owner on receipt of the camera. This ensures added protection against unauthorised access to the Security menu.

Standard customer file

The green button on the side of the camera recalls the standard scene file. This file contains standard parameters for the picture performance.

A standard operator's file can be recalled via the Files menu. This file contains parameters for the set-up of the camera.

A customer standard file can be defined for the standard scene file and for the standard operator's file.

The contents of the customer files for both these standard files is stored via the security menu. The selection of a factory defined or a customer defined file for use as a standard file is also made in this menu.

Files Menu Features

A user of the LDK 200 camera can have access to 15 different files. This number can be extended by using additional scene file smart cards. The Files menu is used to recall and store these files. There are two types of file:

- * scene files
- * operator files.

A scene file contains values related to the picture performance. The operator file contains values related to the set-up of the camera (viewfinder, lens and installation parameters).

The appendix indicates the functions that are stored in the scene file and those functions that are stored in an operator file.

Scene files

Four scene files are stored in the camera itself (SCAM1, SCAM2, SCAM3 and SCAM4). Another four scene files can be stored on the smart card (SCARD1, SCARD2, SCARD3 and SCARD4).

A STANDARD scene file (preselected as either factory or customer defined) is stored in the camera.

Note:

The standard customer scene file is stored via the Security menu, not the Files menu. The decision to use the factory defined file or the customer defined file as the standard file is also made in this menu.

The Files menu enables the scene files to be stored and recalled using the store and recall entries of the menu system.

If the message NOK is displayed then the old values are restored. If the camera is on-air when a scene file is recalled then the recalled values do not become active until the camera goes off air.

Operator files

The Files menu also allows the recall of the operator file stored in the camera (OCAM1) or one of the two operator files (OCARD1 and OCARD2) stored on the smart card. These files contain information for setting up the non-video configuration of the camera.

A STANDARD operator files (factory or customer defined) is stored in the camera.

Note:

The standard customer operator file is stored via the Security menu, not the Files menu. The decision to use the factory defined file or the customer defined file as the standard file is also made in this menu.

Install Menu Features

Gain

The gain can be selected in five steps: -, 0, +, ++ and +++. The actual value of the gain in dB can be assigned to these symbols. This is done in the Install menu.

The "-" can be set to -6dB or -3dB.

The '0' is always 0dB.

The '+' can be set to 6, 9, 12 or 18dB .

The '++' can be set to 9, 12, 18 or 24dB.

The "+++" can be set to: 30 or 36dB

Disable camera

The disable camera function is a protection function which prevents unauthorised interference with the camera and provides an additional level of security. Setting disable camera to ON is similar to using User level 0 to protect the settings of the camera.

Appendix

Contents

List of Abbreviations A-2

List of Abbreviations

Abbreviation	Meaning
adap	adapter
agc	automatic gain control
awb	automatic white balance
bal	balance
cam	camera
ch	channel
cont	contour
ctemp	colour temperature
ctl	control track longitudinal
cus	customer
df	drop frame
dyn	dynamic
exec	execute
exp	exposure
ext	external
ext	extended
flt	filter
fr	front
frm	frame
f-run	free run
hd	head
hr	hour
ind	indicator
info	information
interv	interview
intv	interview
ir	infra-red
lvl	level
man	manual
max	maximum
mic	microphone
min	minute
min	minimum
mom	momentary
mon	monitor
nam	non-additive mix
nd	neutral density
ndf	no drop frame

Abbreviation	Meaning
ocam	camera operator file
ocard	smart card operator file
op	operation
oper	operator
outp	output
ovl	overload
pin	personal identification
number	
r/w	read/write
re	rear
repl	replay
r-run	record run
rst	reset
sawt	sawtooth
scam	camera scene file
scard	smart card scene file
sec	second
sel	select
srch	search
st	stereo
std	standard
str	stretch
tc	time code
tm	timer
ub	user bits
unbal	unbalanced
und	underload
var	variable
ver	version
vert	vertical
vf	viewfinder
wa	wide angle
wh	white
wm	warning
wrx	wireless receiver