

User's Guide

3922 496 30031
version 4

LDK 300
CAMERA SYSTEM

Declaration of Conformity

We, Thomson Broadcast and Media Solutions B.V., Kapittelweg 10, 4827 HG Breda, The Netherlands, declare under our sole responsibility that this product is in compliance with the following standards:

- EN60065 : Safety
- EN55103-1 : EMC (Emission)
- EN55103-2 : EMC (Immunity)

following the provisions of:

- a. the Safety Directives 73/23/EEC and 93/68/EEC
- b. the EMC Directives 89/336/EEC and 93/68/EEC

FCC Class A Statement

This product generates, uses, and can radiate radio frequency energy and if not installed and used in accordance with the instructions, may cause interference to radio communications.

It has been tested and found to comply with the limits for a class A digital device pursuant to part 15 of the FCC rules, which are designed to provide reasonable protection against such interference when operated in a commercial environment.

Operation of this product in a residential area is likely to cause interference in which case the user at his own expense will be required to take whatever measures may be required to correct the interference.

Copyright

Für diese Unterlage behalten wir uns alle Rechte vor (Gemäß DIN 34). Technische Änderungen im Zuge der Weiterentwicklung vorbehalten.

Copying of this document and giving it to others, and the use or communication of the contents thereof, are forbidden without express authority. Offenders are liable to the payment of damages. All rights are reserved in the event of the grant of a patent or the registration of a utility model or design. Liable to technical alterations in the course of further development.

Toute communication ou reproduction de ce document, toute exploitation ou communication de son contenu sont interdites, sauf autorisation expresse. Tout manquement à cette règle est illicite et expose son auteur au versement de dommages et intérêts. Tous nos droits sont réservés pour le cas de la délivrance d'un modèle d'utilité. Sous réserve de modification au cours de l'évolution technique.

Table of Contents

Chapter 1 – Introduction

Technology	1-1
Frame Transfer DPM sensor	1-1
Digital Processing	1-2
Film-like characteristics	1-2
Features	1-2
Specifications	1-4
Dimensions	1-6
Accessories	1-7

Chapter 2 – Installation

Packing/unpacking	2-1
Transport case	2-2
Mounting a lens	2-3
1.5-inch Viewfinder	2-4
Mounting viewfinder and microphone holder	2-4
Positioning the viewfinder	2-5
1.5-inch Viewfinder Accessories	2-5
Wide angle eyepiece	2-5
Left eye adapter	2-6
Mounting a microphone	2-7
Tripod adapter plate	2-8
Adjusting the shoulder pad	2-9
Mounting a top light	2-9
Zoom controls	2-10
Attaching an adapter	2-11

Chapter 3 – Cabling and connectors

Configurations	3-2
Camera with Triax adapter	3-2
Multiple Triax cameras with C2IP network	3-2
Camera with Triax adapter and SuperXpander	3-4
Camera connectors	3-5
Viewfinder connector	3-5
Lens connector	3-6
Audio microphone connector	3-6
RS232 serial connector	3-7

Triax adapter connectors	3-8
Triax connector	3-9
CVBS output connector	3-9
Viewfinder / External video output connector	3-9
Script light power supply socket	3-10
Teleprompter video output connector	3-10
DC power and tally output socket	3-10
Audio microphone 2 connector	3-11
DC power input socket	3-11
Audio microphone 1 connector	3-12
Intercom headset connector	3-12
Reference input connector	3-13
Tracker communications connector	3-13
Auxiliary connector	3-14

Chapter 4 – Operating instructions

Camera head controls	4-3
Viewfinder controls	4-4
Assigning functions to buttons	4-5
Using the camera	4-6
Switching on the power	4-6
Controlling the camera	4-6
Access and Security	4-7
Camera cards	4-7
Access control	4-8
Camera card slot	4-8
System Menu	4-9
Entering the System menu	4-9
Finding your way	4-10
Leaving the System Menu	4-10
Making changes	4-11
Undoing changes	4-11
Viewfinder preferences	4-12
Viewfinder picture quality	4-12
Video level indication	4-12
Tally indicators	4-12
Viewfinder markers	4-12
Lens preferences	4-13
Lens type	4-13
Auto iris	4-13
Extended Iris	4-13
Lens indicators	4-13
Video preferences	4-14
Standard settings	4-14
Test signal	4-14
Gain selection	4-15
Optical filter selection	4-15
Colour temperature selection	4-16
Exposure time	4-18
Black stretch	4-21
Auto skin contour	4-21
Classic mode	4-22

Managing files	4-22
Scene files	4-22
Operator files	4-23
Standard files	4-23
Customer standard files	4-23
User levels	4-23
Selecting the user level	4-24
Smart-Touch™	4-24
Triax adapter controls	4-26
Powering the camera	4-27
Selecting monitoring signals	4-27
Using audio	4-27
Intercom	4-28
Communication	4-29

Chapter 5 – Menu structure

Menu structure	5-2
Main (top) menu	5-2
Where to find a function	5-6



Chapter 1

Introduction

This section outlines the technology used in the camera system and describes how this translates into a practical, useable camera. It lists the main features of the camera.

Contents

Technology	1-1
Frame Transfer DPM sensor	1-1
Digital Processing	1-2
Film-like characteristics	1-2
Features	1-2
Specifications	1-4
Dimensions	1-6
Accessories	1-7

1.1 Technology

The camera head uses three 2/3-inch CCD sensors. It is available with DPM, FT, IT or ITW type sensors. A range of adapters can be connected to the head making a flexible camera system that is equally at home in the studio or out on location in an OB environment.

1.1.1 Frame Transfer DPM sensor

The Frame Transfer CCD DPM sensor offers superior performance and can handle highlights of up to 600%. The 2/3-inch sensors have a high dynamic range and high linear sensitivity over all camera lens apertures. Frame Transfer technology ensures that there is no lag nor smear. The Frame Transfer DPM sensor uses Dynamic Pixel Management which allows the format of the sensors to be switched between 4:3 and 16:9 aspect ratios at the touch of a switch without loss of horizontal or vertical resolution. The 1000 pixels per line in both formats ensures that there is no loss in the horizontal viewing angle but also ensures high resolution in the red, green and blue channels.

1.1.2 Digital Processing

The advanced digital processing of the camera is based on 12-bit A/D converters and more than 20-bit internal processing. Two DSPs combine all major camera functions in the digital domain, including knee, gamma, contour, matrix and colour correction.

The intelligent continuous automatics facility provides automatic control of black levels and black shading. Each sensor provides black reference signals that are used to monitor temperature changes. This means that continuous automatic correction is applied without operator intervention.

The digital contour processing uses full amplitude video RGB signals via an extended dynamic range contour circuit.

Colorimetry is selected by means of a variable 6-point digital matrix or via preset matrices. Digital gamma circuits provide a wide range of standardised gamma curves and enable soft contrast in black scenes to be enhanced, together with hard contrast and saturated colour in bright scenes. The matrix and gamma sequence is software programmable for precise colour matching.

1.1.3 Film-like characteristics

The pivoting knee circuit adapts both the knee point and the compression ratio according to the highlight content of the picture to emulate the softly limiting S-shaped transfer characteristics of film. Digital True Colour Knee circuitry maintains the correct hue for compressed highlights, reproducing colours faithfully, even overexposed skin tones.

Digital contrast circuitry provides a black stretch function for more detail in black areas and a black press function for improving the contrast impression by simulating the S-curve of film.

1.2 Features

- Three 2/3-inch switchable DPM FT sensors ensure no vertical smear.
 - DPM Frame Transfer sensors with 1000 horizontal pixels in 4:3 and 16:9 aspect ratios, and the same number of vertical lines in both formats. No change in horizontal viewing angle - so no optical wide angle convertors required.
 - 12-bit digital processing with unique software programmable video path.
 - Superior all digital highlight handling with a wide dynamic range.
 - Unique circuitry for pivoting knee and True Colour Knee.
 - Wide range of presets and variable 6-point digital matrix assure accurate colour matching.
 - Fluorescent light matrix
 - Digital gamma with unique standard preset values and highest accuracy.
 - Digital contour with an extensive range of parameters.
 - Advanced contour correction includes two automatic skin settings.
-

- Intelligent Continuous Automatics black levels, black shading and video levels - no set-up time required.
- Digital contrast with standard black stretch and black press.
- International standard 2/3-inch lens interface.
- Optical servo-controlled, four-position neutral density filter wheel.
- Optical servo-controlled, effect filter wheel (some versions only).
- Electronic colour filter for creating a special look (warm/cold) for a scene, or for a smooth colour temperature control around the white balance setting.
- Camera card for personal settings and security.
- Owner's card for setting user levels, and for copying and storing control settings.
- Protected, easy-to-operate controls and switches with read-out of all settings.
- Viewfinder status read-out of primary camera functions.
- Clean scan feature allows capture of computer and other monitor pictures.
- Digital RS232 serial interface to PC.

Options

- Zoom control handgrip makes awkward shots easy.
 - Transport case.
 - Smart-Touch gives the operator instant, one-button access to 14 pre-defined shooting characteristics.
-

1.3 Specifications

Table 1-1. LDK 300 Camera Head DPM FT version

Item	Value
Power requirements	supplied via adapter
Power consumption	35 W (Head + VF)
Operating temperatures	-20 to +45°C (-4 to +113°F)
Storage temperatures	-20 to +60°C (-4 to +140°F)
Weight (approx.)	4.8 kg incl. 1.5-inch VF and adapter
Pick-up device	3 x 2/3-inch DPM Frame Transfer CCDs Aspect ratio switchable 4:3 and 16:9
Picture elements	NTSC: 1000(h) x 498(v) PAL: 1000(h) x 594(v)
Digital quantization	12-bit A to D
Digital signal processing	18 MHz and 36 MHz, 24-bit accuracy
Sensitivity	2000 lux at F9.0 reflectance 90%
Minimum illumination	Approx. 2 lux at F 1.4 and +30 dB gain
Exposure control	Down to 1/1000
Clean scanning	NTSC: between 61.1 and 151.0 Hz PAL: between 51.0 and 103.0 Hz
Optical system	F1.4 with quartz filter
Optical filters	Clear, 1/4 ND, 1/16 ND, 1/64 ND Clear, 4-point star, 6-point star, soft focus
Modulation depth	70% at 5Mhz 65% at 5Mhz with Hires Digital Noise Slicer
S/N ratio	Typical: 63 dB NTSC Typical: 61 dB PAL
Registration	<25 ns (0.05%) in all zones, without lens
Dynamic range	>600%
Gain	-6dB to +30dB in 3dB steps (user defined presets)
Viewfinder type	1.5-inch B/W
Viewfinder resolution	> 600 TV lines

Table 1-2. LDK 5430 Triax Adapter

Item	Value
Power requirements	Triax powered or 12 Vdc
Operating temperatures	-20 to +45°C (-4 to +113°F)
Storage temperatures	-20 to +60°C (-4 to +140°F)
Weight (approx.)	2.3 kg
Dimensions	220 (L) x 120 (W) x 205 (H) without handgrip
Triax in/out	Swivel connector; Fischer, ARD, Lemo or Trilock
Triax cable length	2.400m (7,875 ft) max. with 16mm (0.63") cable 3000m with RGB long triax modification (optional)
Intercom	XLR5/Tuchel with channels ENG/PROD/PROG
Video (CVBS) out	Optional: 1 Vpp; 75 Ohm; BNC
Video teleprompter out	1 Vpp; 75 Ohm; BNC
Monitor (Y)	1 Vpp; 75 Ohm; BNC
Reference in	1 Vpp; 75 Ohm; BNC
Tracker	11 pins Communication / Signalling
Auxiliary/ Data	11 pins private data
Rear microphone in (2x)	XLR 3, balanced, +48V
DC12Volts in	XLR-4 male
Scriptlight power	12 Volts, 0,25A, 3-pin Fisher
DC12Volts out	4-pin Fisher 1.5 Amp.

1.3.1 Dimensions

Figure 1-1. Dimensions

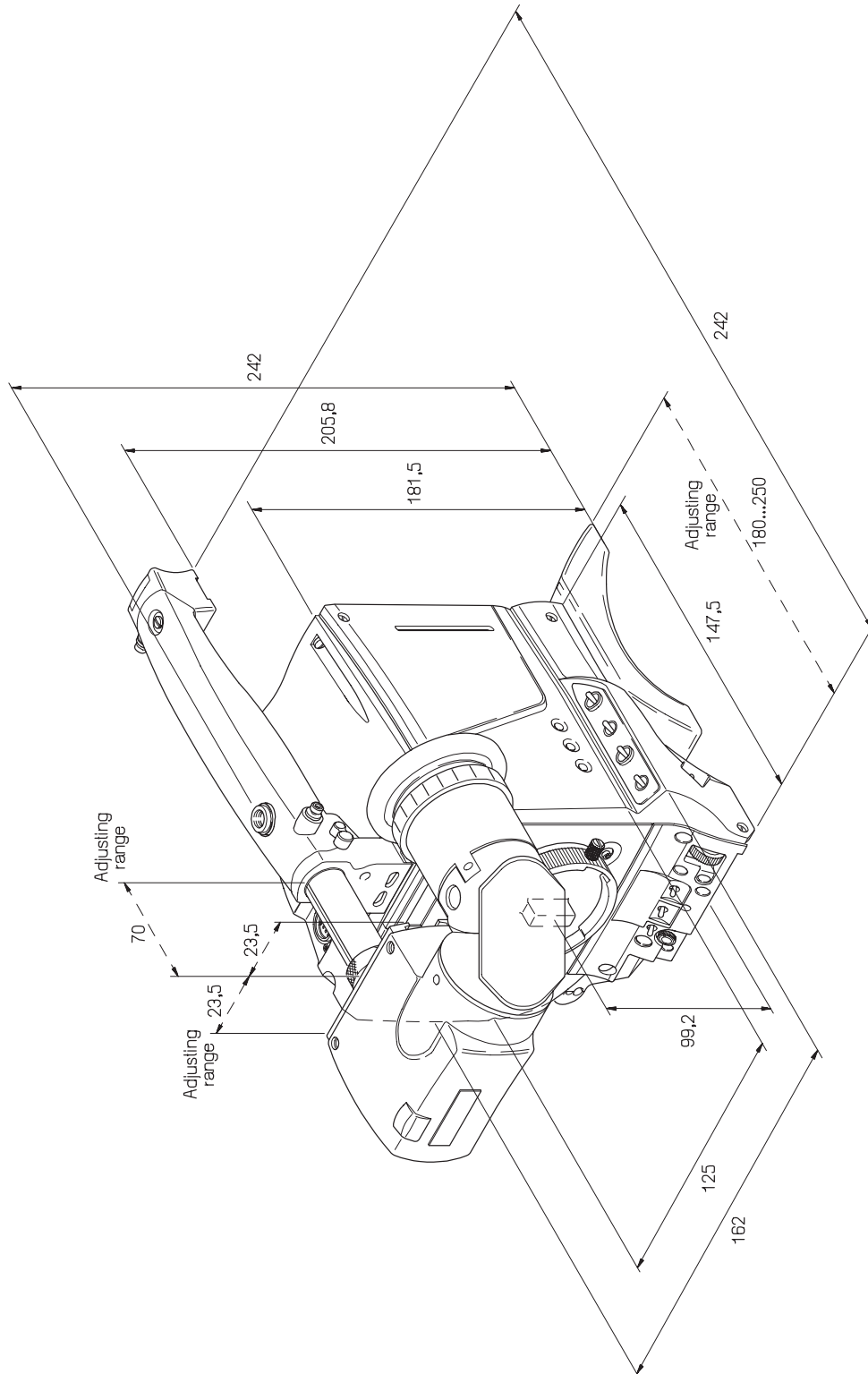

1.4 Accessories

SuperXpander	LDK 4482/00
5-inch viewfinder 50Hz	LDK 5310/00
5-inch viewfinder 60Hz	LDK 5310/50
7-inch viewfinder 50Hz	LDK4016/00
7-inch viewfinder 60Hz	LDK 4016/50
7-inch viewfinder support	LDK 6517/00
Wide Angle adapter 1.5" vf	LDK 5390/00
Sunhood for 5" VF	LDK 6992/02
Raincover DVCPRO camcorder	LDK 5021/01
Raincover camera with 5" VF	LDK 5021/05
Raincover camera with SuperXpander	LDK 6989/00
Tripod plate	LDK 5031/00
Headset dynamic XLR-5 double muff	LDK 8111/37
Headset dynamic XLR-5 single muff	LDK 8111/51
Scriptboard with light	LDK 6985/21
Transport/flightcase	LDK 5020/00
Carrying bag	LDK 5020/01
Camera light 20W	LDK 5950/00
AC power supply	LDK 4377/40
Camera (IR) remote control	LDK 5200/00
Zoombox for Angenieux lenses	LDK 6113/16
Zoomcontrol for Canon lenses	LDK 6113/26
Zoombox for Fujinon lenses	LDK 6113/36
Camera cable triax 8mm Fischer	LDK 8107/yy
Camera cable triax 11mm Fischer	LDK 8109/yy
Camera cable triax 14mm Fischer	LDK 8112/yy
Camera cable triax 8mm ARD	LDK 8116/yy
Camera cable triax 11mm ARD	LDK 8117/yy
Camera cable triax 8mm LEMO	LDK 8119/yy

yy: 01= 10 m, 10= 100m, 99= 990m



Chapter 2

Installation

This section describes how to physically set-up the camera system and how to attach accessories. Information is also provided on the connectors used in the camera and adapter.

Contents

Packing/unpacking	2-1
Transport case	2-2
Mounting a lens	2-3
1.5-inch Viewfinder	2-4
Mounting viewfinder and microphone holder	2-4
Positioning the viewfinder	2-5
1.5-inch Viewfinder Accessories	2-5
Wide angle eyepiece	2-5
Left eye adapter	2-6
Mounting a microphone	2-7
Tripod adapter plate	2-8
Adjusting the shoulder pad	2-9
Mounting a top light	2-9
Zoom controls	2-10
Attaching an adapter	2-11

2.1 Packing/unpacking

Inspect the shipping container for evidence of damage immediately after receipt. If the shipping container or cushioning material is damaged, it should be kept until the contents of the shipment have been checked for completeness and the units have been checked mechanically and electrically.

The shipping container should be placed upright and opened from the top. Remove the cushioning material and lift out the contents. The contents of the shipment should be checked against the packing list. If the contents are incomplete, if there is mechanical damage or defect, or if the units do not perform correctly when unpacked, notify your Thomson Broadcast and Media Solutions sales or service centre within eight days. If the shipping container shows signs of damage or stress, notify the carrier as well.

If a unit is being returned to Thomson Broadcast and Media Solutions for servicing, try to use the containers and materials of the original packaging. Attach a tag indicating the type of service required, return address, model number, full serial number and the return number which will be supplied by your Thomson Broadcast and Media Solutions service centre.

If the original packing can no longer be used, the following general instructions should be used for repacking with commercially available materials:

1. Wrap unit in heavy paper or plastic.
2. Use strong shipping container.
3. Use a layer of shock-absorbing material around all sides of the unit to provide firm cushioning and prevent movement inside container.
4. Seal shipping container securely.
5. Mark shipping container FRAGILE to ensure careful handling.

2.2 Transport case

It is important to protect your camera against damage when transporting it. To do this, a transport case (LDK 5020/00) is optionally available for the camera, lens, viewfinder and some accessories.

Figure 2-1. Transport case

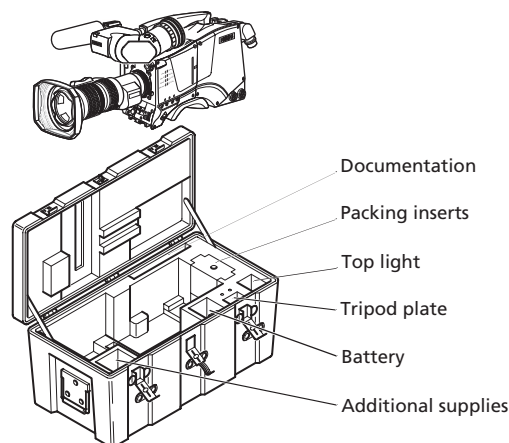

The camera is packed in the transport case as shown in the figure above. This ensures that the camera is not damaged during transport. Turn the 1.5-inch viewfinder downwards so that it does not protrude above the top of the camera. Several foam packing inserts are provided to enable different configurations of the camera to be packed securely. These inserts are used to support the rear of the camera. Make sure you use the correct foam insert for your particular configuration.

2.3 Mounting a lens

To attach a lens to the camera head proceed as follows:

1. Ensure that the lens locking ring (1) is in the unlocked position - turned counterclockwise.
2. Remove the dust protection cap (2).
3. Slot the lens into the lens mount (3).
4. Turn the lens locking ring (1) clockwise to lock the lens in place.
5. Connect the lens cable to the lens connector (4) at the right side of the camera.
6. Place the lens cable into the bottom clip at the front of the camera and clip (5) located at the side. (Pull and twist clip to open it.)

Figure 2-2. Lens mounting

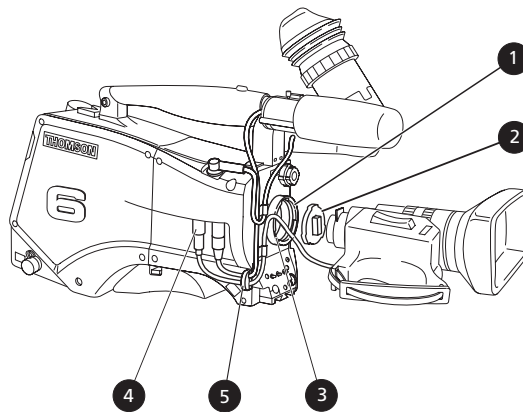

Caution

Do not attach a lens weighing more than 5 kg to the camera without a support.

When a new lens is fitted to the camera it may be necessary to carry out some adjustments to optimize its use, for example, back focus or shading. For more information about these adjustments refer to the lens manufacturer's documentation



Note

Always mount the dust protection cap when the lens is not connected to the camera.

2.4 1.5-inch Viewfinder

2.4.1 Mounting viewfinder and microphone holder

To mount the 1.5-inch viewfinder proceed as follows:

1. Loosen locking ring (1) of viewfinder support bracket (2) at the front of the camera handle. (As seen from the rear of the camera, turning the locking ring counterclockwise moves it towards the handle.)
2. Slide the viewfinder onto the viewfinder support bracket.
3. Tighten the locking ring (1) by turning it clockwise (as seen from rear) so that the viewfinder is mounted securely to the support.
4. Connect the viewfinder cable to the viewfinder connector socket (6) at the top right of the camera.
5. Slide the microphone holder (4) onto the viewfinder and secure with the knurled screw (5).



Caution

Always fit the microphone holder as it functions as a safety stop for the viewfinder.

6. To improve the comfort of the skin contact when using the viewfinder, fit the eye piece cover (3) to the rubber eyepiece. Spare eye piece covers (3922 405 00461) are available at your Thomson Broadcast and Media Solutions representative.

Figure 2-3. Viewfinder mounting

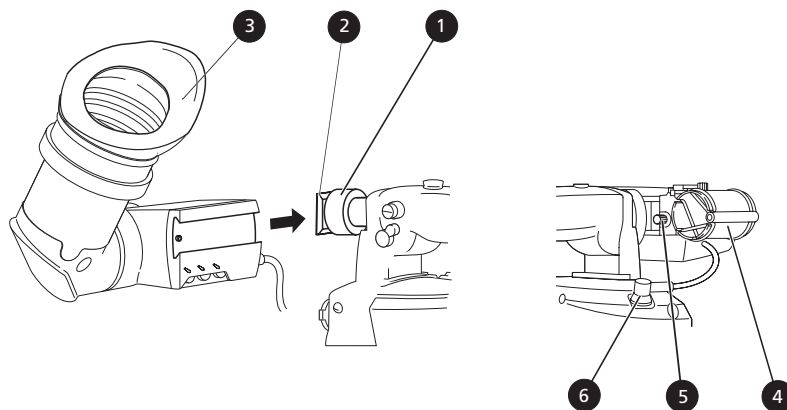

2.4.2 Positioning the viewfinder

The horizontal position of the viewfinder can be adjusted as follows to suit your requirements:

1. Loosen the locking ring (1). (As seen from the rear of the camera, turning the locking ring counterclockwise moves it towards the handle.)
2. Slide the viewfinder horizontally along the rail to the desired position.
3. Tighten the locking ring (1) by turning clockwise.

The dioptre hood and eyepiece of the viewfinder can be rotated vertically.

The viewfinder can be positioned backwards and forwards along the camera axis. Loosen the support bracket round bar retaining lever (2) and slide the round bar (3) forwards or backwards. When the desired position is reached tighten the support bracket round bar retaining lever (2) again.

To use the viewfinder at a distance press the button (4) below or above the eyepiece tube and swing it free of the associated clip (5). The display can now be seen from further away.

Figure 2-4. Viewfinder positioning

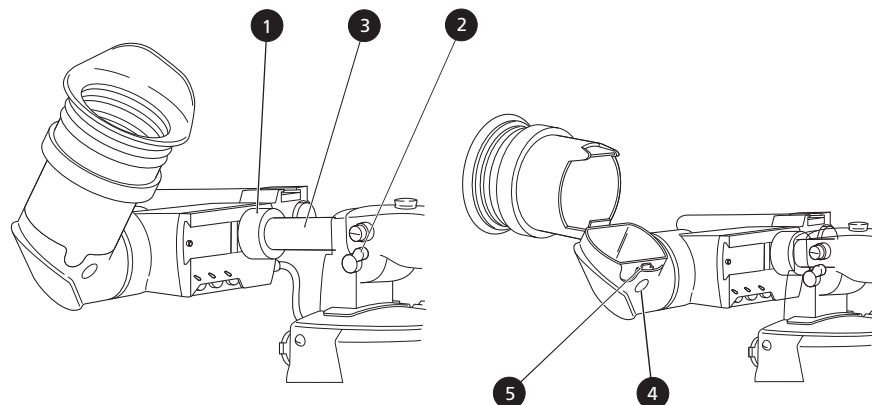

2.5 1.5-inch Viewfinder Accessories

2.5.1 Wide angle eyepiece

If you regularly use the viewfinder at a distance, for example, when you use the camera in the hand-held position, it is recommended that you fit the optionally available wide angle eyepiece (LDK 5390/00).

To fit the wide angle eyepiece proceed as follows:

1. Hold the eyepiece (1) securely.
2. Press the button (2) below the eyepiece tube and swing it free of the button clip (3).

3. Press the button (4) above the eyepiece tube and remove the eyepiece.
4. Fit the wide angle eyepiece (1) to the two clips (3) ensuring that they both click into place.

Figure 2-5. Viewfinder wide angle eyepiece

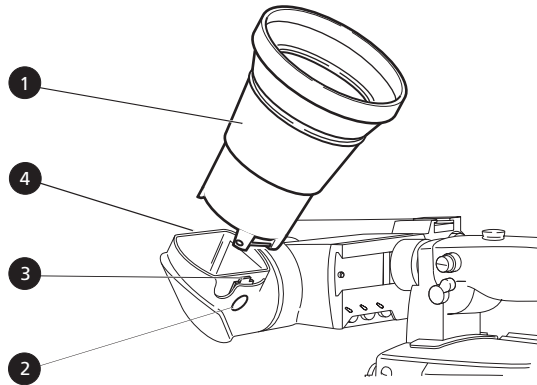

2.5.2 Left eye adapter

A left eye adapter is optionally available (LDK 5390/10) to allow the viewfinder to be used with the left eye.

Before mounting the viewfinder onto the camera, attach the left eye adapter (1) to the viewfinder and secure it using the screw (2). Do not forget to mount the microphone support bracket (3) at the end of the left eye adapter.

Figure 2-6. Viewfinder left eye adapter

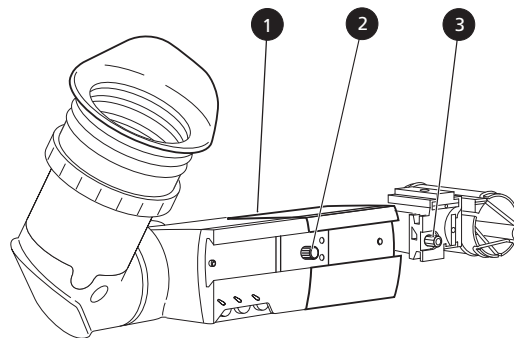

2.6 Mounting a microphone

To attach the optional microphone (AJ MC700) to the camera proceed as follows:

1. Open the microphone holder by unscrewing the knurled screw (2) of the microphone support bracket (1) on the viewfinder and open.
2. Slide the microphone into the split tube until the microphone shoulder reaches the mark (5) in the tube.
3. Place the tube with the microphone into the holder with the split facing upwards.
4. Ensure that the rubber supports at the back and front of the holder fit into the rims (6) around the tube.
5. Close the holder and tighten the knurled screw at the top.
6. Connect the microphone cable to audio connector (3) (mic) on the right side of the camera.
7. Place the microphone cable into the top clip at the front of the camera and into clip (4) at the side of the camera. (Pull and twist clip to open it.)

Other microphones with a diameter of 21mm can also be used, however, ensure that the phantom power and the sensitivity of the input that match that type of microphone are correctly selected in the camera systems menu.



Note

When longer microphones are used, it is not necessary to place them in the split tube. For optimum operation, the microphone should be mounted as straight as possible. Don't allow the wind hood to touch the holder (7) as this reduces the damping effect. By placing the split facing upwards, the microphone cable does not touch the holder thus avoiding mechanical pick-up.

Figure 2-7. Microphone mounting

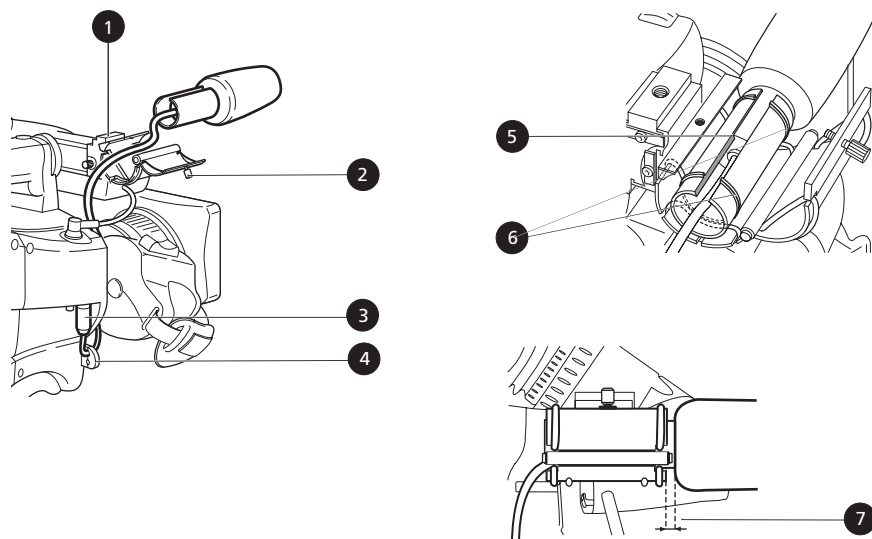

2.7 Tripod adapter plate

To mount the camera on a tripod, the tripod plate (LDK 5031/00 is delivered as standard) must first be attached to the tripod. Follow the tripod manufacturer's instructions to mount the wedge plate supplied with the tripod and the tripod adapter plate firmly onto the tripod. Attach the camera to the tripod adapter plate as follows:

1. Slide the camera horizontally along the tripod adapter plate from back to front ensuring that the front of the camera engages the V-slot (1) at the front of the tripod adapter plate, and that the slot on the bottom of the camera engages the stud (2) at the rear of the tripod adapter plate.
2. Firmly push the camera forward until it clicks into place.



Caution

Failure to attach the camera to the tripod adapter plate in the correct manner could result in an unsecured camera. Ensure that the rear stud (2) is engaged and that the camera clicks into place.

Remove the camera from the tripod as follows:

1. Press the red locking lever (3) against release handle (4) on the tripod adapter plate and hold.
2. Ensure that you have a firm hold of the camera.
3. Pull the release handle (4) forward.
4. Move the camera backwards and up. The camera is now free from the tripod adapter plate.

Figure 2-8. Tripod adapter plate

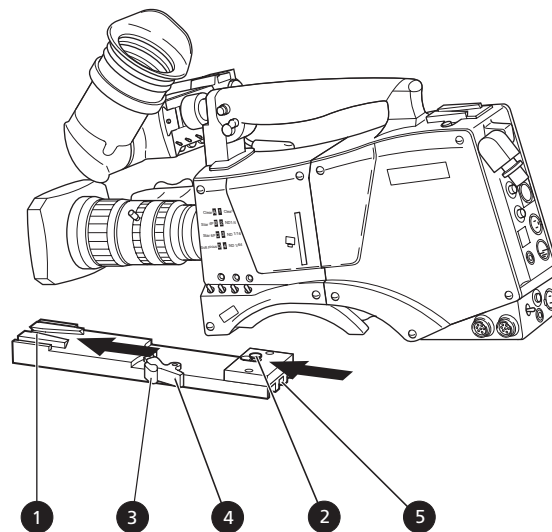

When a 5-inch viewfinder is used with the camera it is recommended that the optionally available tripod adapter plate LDK 5030 be used. This tripod plate has an extra locking lever (5) at the rear which provides an additional clamp for the rear stud

and so gives extra stability to the mount. When the camera is mounted on the tripod tighten this locking lever (5) to ensure that the stud (2) at the rear of the plate is locked firmly in place. When removing the camera first open the locking lever (5) to free the rear stud (2).

2.8 Adjusting the shoulder pad

To change the position the shoulder pad press and hold lever (1). The shoulder pad can now be moved backwards and forwards along the axis of the camera. Adjust the shoulder pad when all units have been mounted so that the best balanced position can be obtained.

Figure 2-9. Shoulder pad

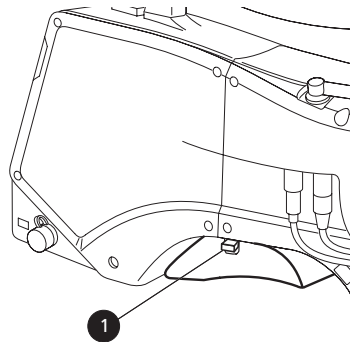

2.9 Mounting a top light

To mount a top light (1) onto the camera, proceed as follows:

1. Screw the top light into either the WW1/4" - 20 screw hole (2) located on the carrying handle or the screw hole (3) on the top of the microphone holder.
2. Power the top light according to the instructions delivered with the light.

Figure 2-10. Top light

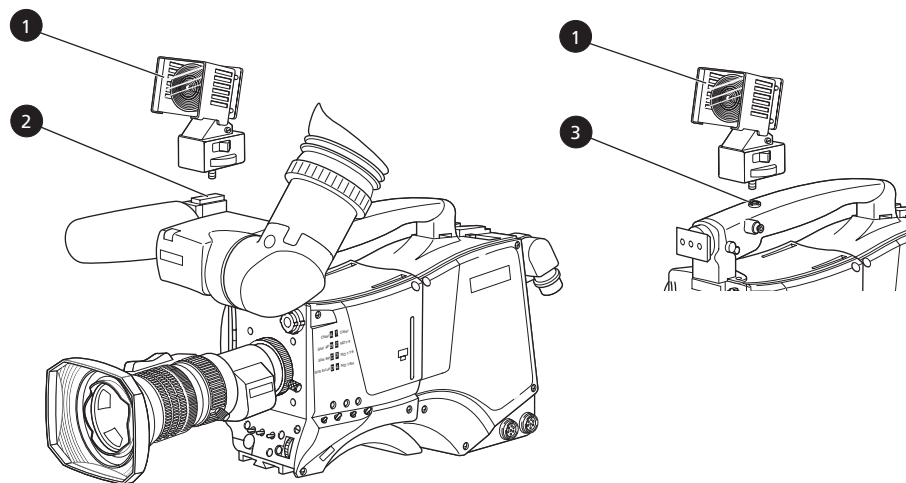

2.10 Zoom controls

An optional zoom control unit (1) can be mounted on the carrying handle. The three available versions for different types of lens are:

- LDK 6113 / 16 for Fujinon.
- LDK 6113 / 26 for Canon.
- LDK 6113 / 36 for Angenieux.

This control unit not only controls the zoom but also has mini-button controls for the VTR start/stop function and the VTR Ret. function. These are located under the front of the carrying handle (2).

The instructions for mounting the zoom control unit and the function of the controls are supplied with the unit.

Figure 2-11. Zoom controls

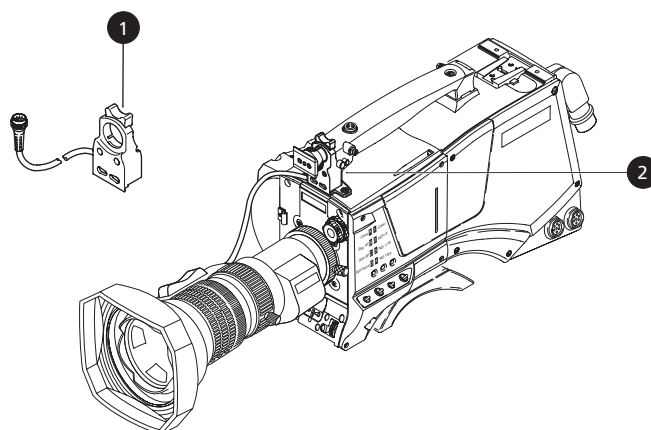

2.11 Attaching an adapter

The LDK 300 camera head is a multi-role camera head that can be used with various adapters.



Caution

Be extremely careful with the connectors between the camera head and the adapter. Do not allow the guide pins to damage the pins of the connector. Follow these steps in the order given. Tightening or loosening the screws in the wrong order could result in mechanical damage to the camera.

To attach an adapter to the camera proceed as follow:

1. Using the rail (1) on the bottom of the camera head as a guide, fit the guide pins (2) on either side of the connector and the guide pin (3) at the top rear of the camera head into the corresponding slots of the adapter.
2. First, tighten the two horizontal screws (4) on the top of camera.
3. Next, tighten the two horizontal screws (5) at the front of the camera.
4. Lastly, tighten the vertical screw (6) in the handle of the camera.

To detach an adapter from the camera head follow the steps for attaching it in the reverse order.

Figure 2-12. Attaching an adapter

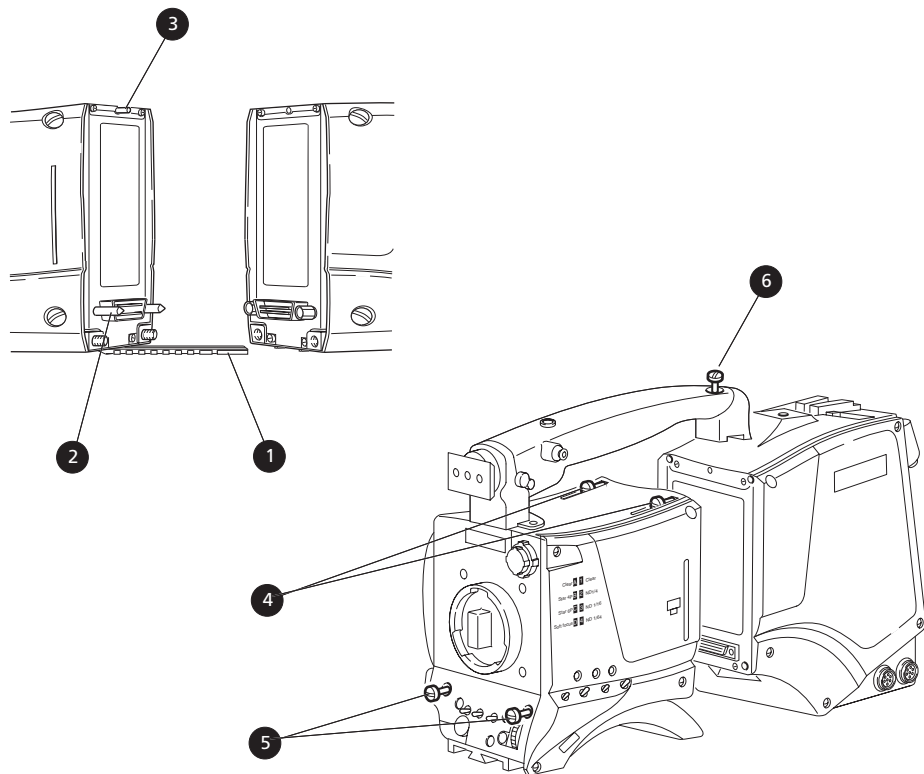



Chapter 3

Cabling and connectors

This section describes how to integrate the camera system into your studio system. Information is also provided on the connectors used in the camera and adapter.

Contents

Configurations	3-2
Camera with Triax adapter	3-2
Multiple Triax cameras with C2IP network	3-2
Camera with Triax adapter and SuperXpander	3-4
Camera connectors	3-5
Viewfinder connector	3-5
Lens connector	3-6
Audio microphone connector	3-6
RS232 serial connector	3-7
Triax adapter connectors	3-8
Triax connector	3-9
CVBS output connector	3-9
Viewfinder / External video output connector	3-9
Script light power supply socket	3-10
Teleprompter video output connector	3-10
DC power and tally output socket	3-10
Audio microphone 2 connector	3-11
DC power input socket	3-11
Audio microphone 1 connector	3-12
Intercom headset connector	3-12
Reference input connector	3-13
Tracker communications connector	3-13
Auxiliary connector	3-14

3.1 Configurations

3.1.1 Camera with Triax adapter

A camera head with an LDK 5430 Triax adapter can be connected to an LDK 4501 Base Station using a Triax cable. The maximum length of cable that can be used without significant degradation of the video signal is 3000m (10,000 ft.) for a 14mm Triax cable. The power supply is applied to the Base Station and via the Triax cable to the camera. An OCP 400 operational control panel can be connected directly to the Base Station using a cross-over Ethernet cable.

Figure 3-1. Camera with Triax adapter

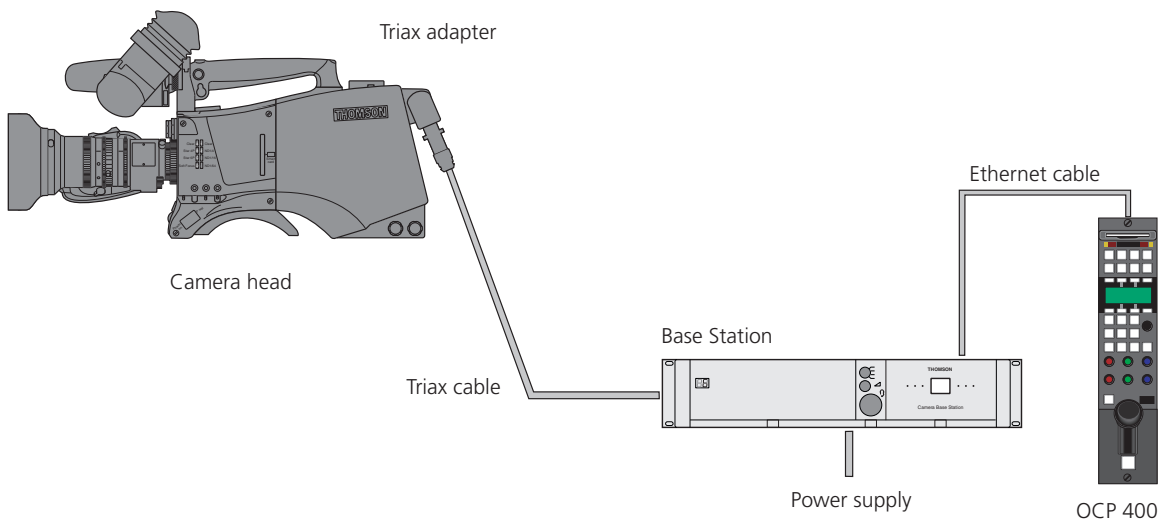

3.1.2 Multiple Triax cameras with C2IP network

Each camera head with an LDK 5430 Triax adapter can be connected to an LDK 4501 Base Station using a Triax cable. The maximum length of cable that can be used without significant degradation of the video signal is 3000m (10,000 ft.) for a 14mm Triax cable. The power supply is applied to the Base Station and via the Triax cable to the camera.

The Base Stations are each connected to a network hub or router via an Ethernet cable (straight through, not cross-over). The OCP 400 operational control panels and, if required the MCP 400 Master Control Panel, are also connected to the Ethernet network via a hub or router.

Optionally, a Series 9000 OCP can be connected directly to a Base Station using a two-wire bus cable. In this situation no loop-through is available and the camera number must be set to 1.

Figure 3-2. Multiple cameras with C2IP network control

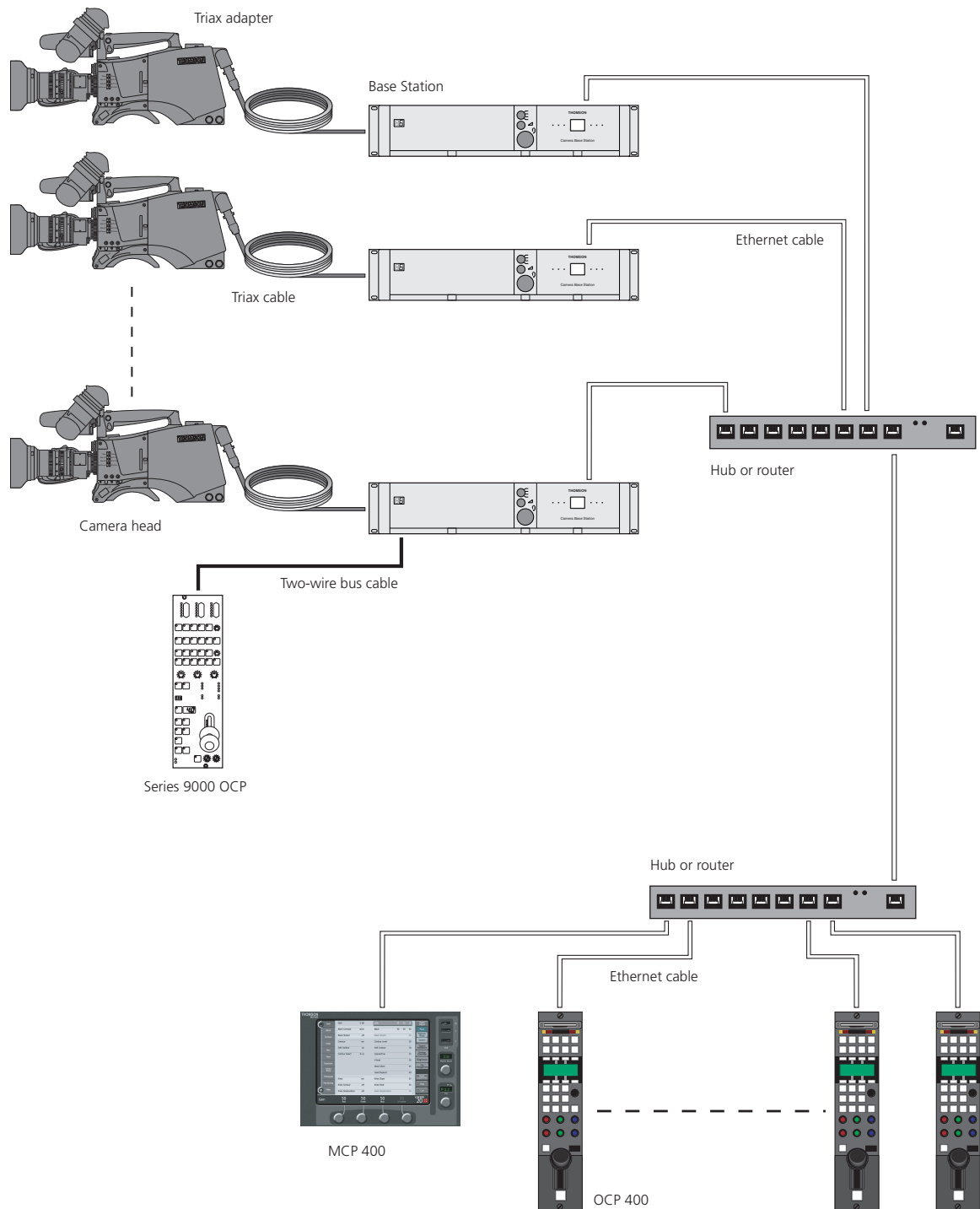

3.1.3 Camera with Triax adapter and SuperXpander

A camera head with an LDK 5430 Triax adapter can be mounted in the LDK 4482 SuperXpander. This enables large box lenses to be used with the camera. The Triax adapter connects to the SuperXpander via a flying lead. A 7-inch viewfinder LDK 4016 is mounted on the SuperXpander. The power supply for the camera is applied to the SuperXpander.

The SuperXpander is connected to an LDK 4501 Base Station using a Triax cable. The maximum length of cable that can be used without significant degradation of the video signal is 3000m (10,000 ft.) for a 14mm Triax cable. The Base Station is powered by a separate mains power supply. An OCP 400 operational control panel can be connected directly to the Base Station using a cross-over Ethernet cable.

Figure 3-3. Camera with SuperXpander and Triax adapter

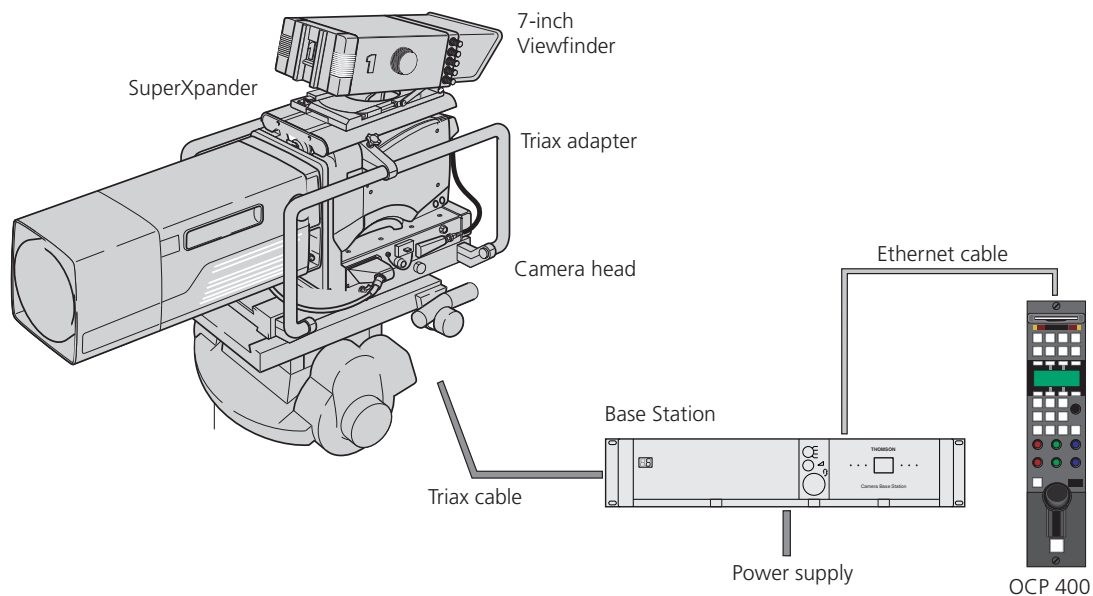

3.2 Camera connectors

Figure 3-4. Camera connector location

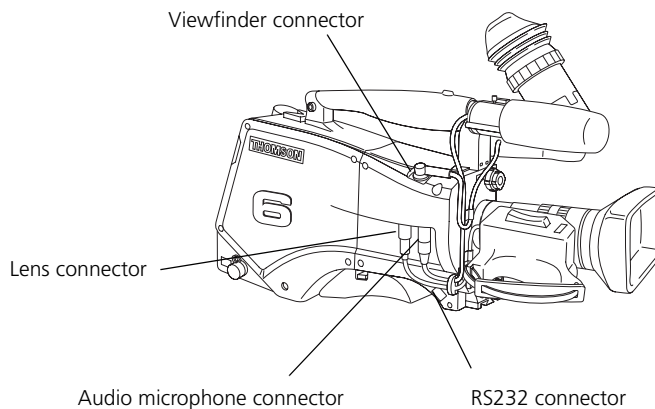

3.2.1 Viewfinder connector

Figure 3-5. Camera viewfinder connector

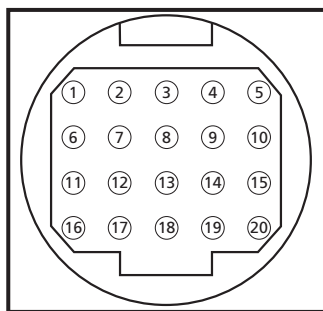

1. -80V	11. GND
2. n.c.	12. vf video
3. GND	13. Pb vf ret
4. INTN-D	14. Pr vf ret
5. vf ext video	15. GND
6. n.c.	16. +batt
7. vf video ret	17. +batt
8. SDA-D	18. Pb vf
9. SCL-D	19. Pr vf
10. vf ext video ret	20. shield

20-pole female; panel view

Panel part number (X14): 5322 214 12544

Cable part number (male): 5322 320 12159

3.2.2 Lens connector

Figure 3-6. Camera lens connector

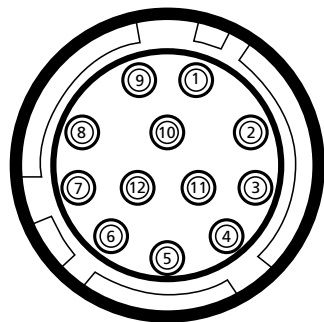

- | | |
|-----------------------|------------------------|
| 1. Ext. Video On/Off | 8. Lens Servo |
| 2. VTR Trigger Switch | 9. Range Extender |
| 3. -batt | 10. Zoom Follow |
| 4. Momentary Iris | 11. Focus follow* |
| 5. IrisControl | 12. Spare |
| 6. + batt | * not standard on lens |
| 7. Iris Follow | |

Hirose 12-pole female; panel view

Panel part number (X15): 5322 265 10389

Cable part number (male): 5322 265 41208

3.2.3 Audio microphone connector

Figure 3-7. Audio microphone connector

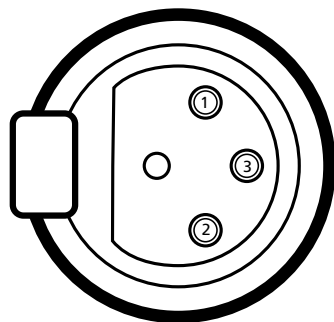

1. Audio Screen
2. Audio In
3. Audio Return

Microphone impedance >200 ohm

Sensitivity range: -70 to -28 dBm

Signal at pin 2 of audio input is in phase with signal at pin 2 of audio output.

XLR 3-pole female; panel view

Panel part number (X13): 5322 267 40523

3.2.4 RS232 serial connector

Figure 3-8. RS232 serial connector

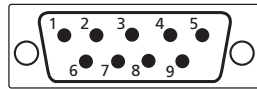

- | | |
|------------|-----------|
| 1. SPARE | 6. RS-DSR |
| 2. RS-RXD | 7. RS-RTS |
| 3. RS-TXD | 8. RS-CTS |
| 4. RS-DTR | 9. +12V |
| 5. RS-DGND | |

SubD 9-pin male; panel view (X12)

3.3 Triax adapter connectors

Figure 3-9. Triax adapter connector location

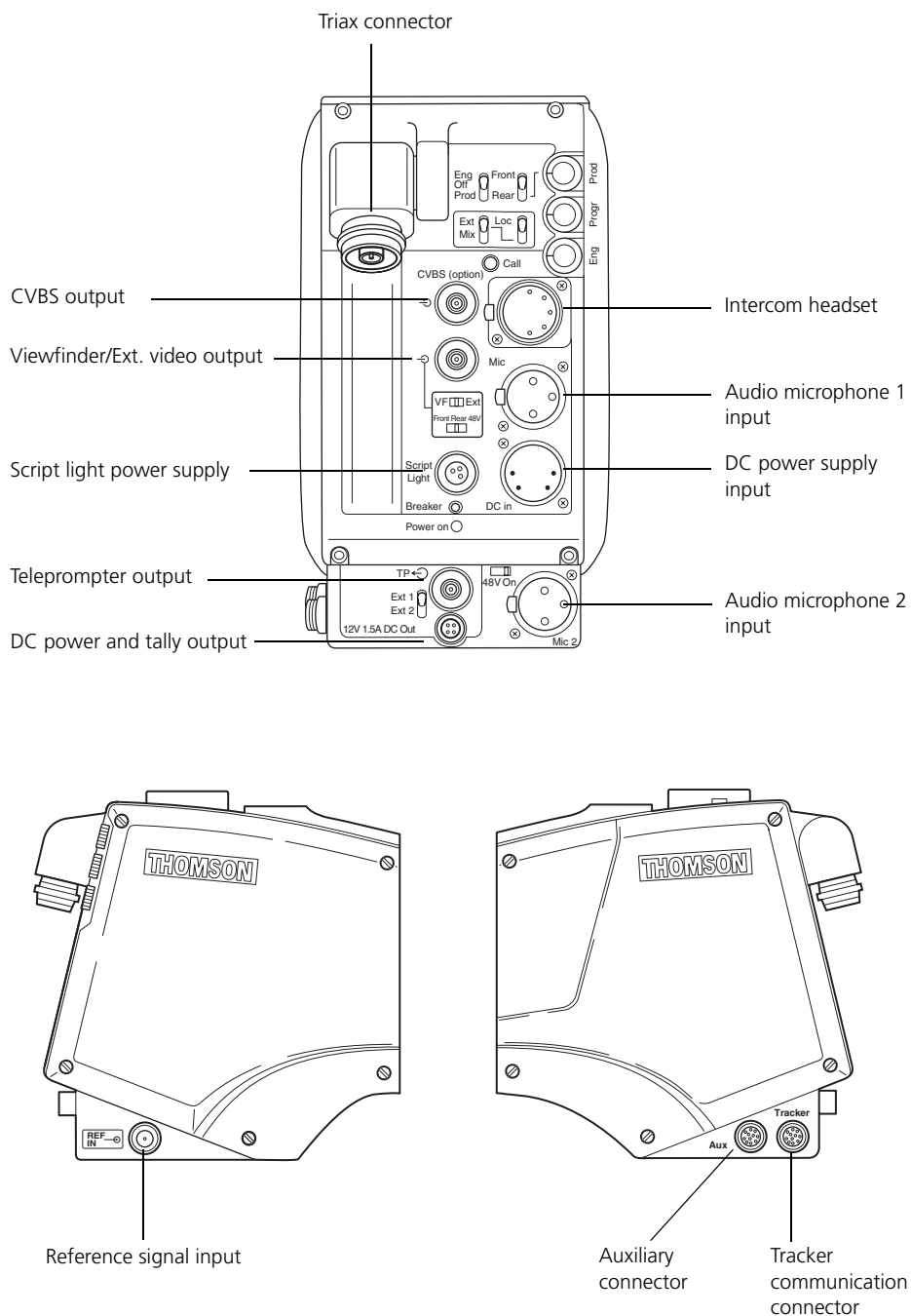

3.3.1 Triax connector

Figure 3-10. Triax connector

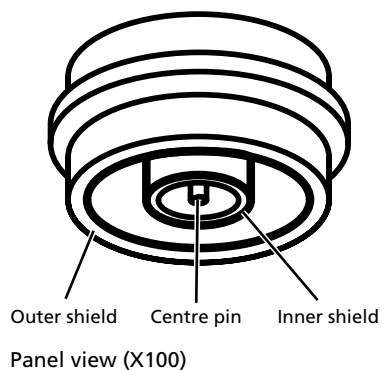

1. Centre pin: Power and signals
2. Inner shield: Return
3. Outer shield: Camera housing GND

3.3.2 CVBS output connector

Figure 3-11. CVBS output connector

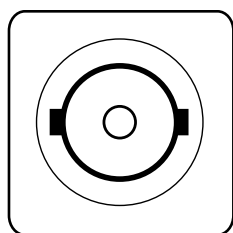

This socket provides a 1.0 Vpp CVBS output video signal if the optional encoder board is fitted.

3.3.3 Viewfinder / External video output connector

Figure 3-12. Viewfinder / External video output connector

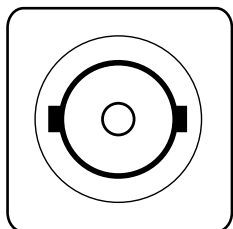

This socket provides a 1.0 Vpp VBS output viewfinder signal or the external video signal from the Base Station.

3.3.4 Script light power supply socket

Figure 3-13. Script light power supply output connector

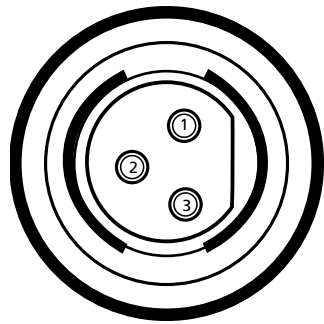

Fischer 3-pole female: panel view (X102)

1. +12 Vdc (maximum dissipation 3W)
2. Power return
3. Shield

3.3.5 Teleprompter video output connector

Figure 3-14. Teleprompter video output connector

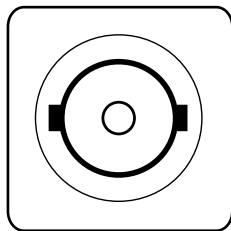

BNC connector: panel view (X112)

This socket supplies the 1Vpp teleprompter signal applied to the Base Station. (This socket has no output if the reference input socket is used as a return video channel).

3.3.6 DC power and tally output socket

Figure 3-15. DC power and tally output connector

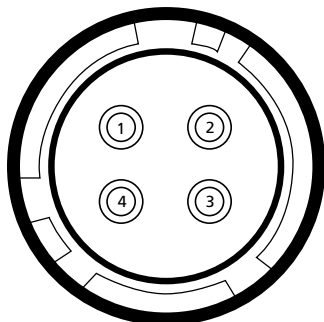

Hirose 4-pole female: panel view (X110)

1. Ground
2. On air
3. No connection
4. +12 Vdc (max. 18W)

Shield of cable directly to the connector housing.

The socket provides access to an internal tally switch. When the camera is on-air, the contact of the internal relay is closed.

3.3.7 Audio microphone 2 connector

Figure 3-16. Audio microphone 2 connector

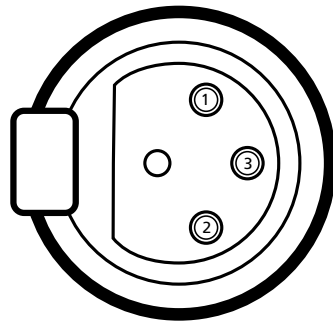

XLR 3-pole female; panel view (X107)

1. Audio Screen
2. Audio In
3. Audio Return

Microphone impedance >200 ohm

Sensitivity range: -64 to -24 dBu

Signal at pin 2 of audio input is in phase with signal at pin 2 of audio output.

3.3.8 DC power input socket



Caution

The input voltage must not exceed +17 Vdc.

Figure 3-17. DC power input connector

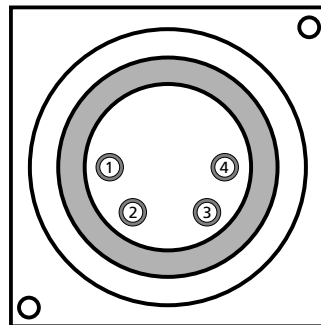

XLR 4-pin male: panel view (X101)

1. Ground
2. No connection
3. No connection
4. +10.5 Vdc . . . +17 Vdc

This socket accepts a DC voltage of 12V nominal.
Maximum power consumption 23W.

3.3.9 Audio microphone 1 connector

Figure 3-18. Audio microphone 1 connector

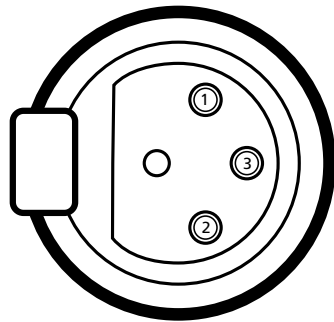

XLR 3-pole female; panel view (X107)

1. Audio Screen
2. Audio In
3. Audio Return

Microphone impedance >200 ohm

Sensitivity range: -64 to -24 dBu

Signal at pin 2 of audio input is in phase with signal at pin 2 of audio output.

3.3.10 Intercom headset connector

Figure 3-19. XLR intercom headset connector

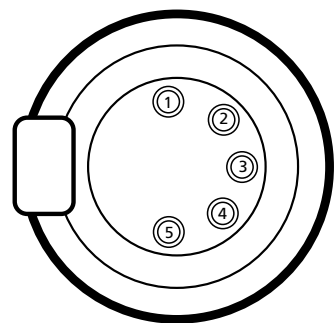

XLR 5-pole female; panel view (X104)

1. Microphone return
2. Microphone
3. Telephone return
4. Telephone left
5. Telephone right

Microphone level: -64 dBu / -24 dBu switchable
Microphone impedance: >600 Ohm

Telephone level: +6 dBu nominal
Telephone output impedance: <50 Ohm

Figure 3-20. Tuchel intercom headset connector

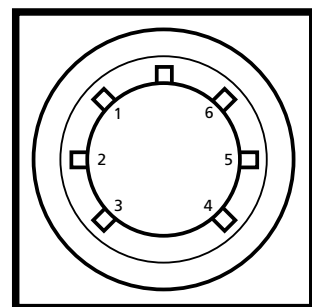

Tuchel 6-pole female; panel view (X104)

1. Telephone left
2. Not connected
3. Microphone
4. Microphone return
5. Telephone right
6. Telephone return

Microphone level: -64 dBu / -24 dBu switchable
Microphone impedance: >600 Ohm

Telephone level: +6 dBu nominal
Telephone output impedance: <50 Ohm

3.3.11 Reference input connector

Figure 3-21. Reference input connector

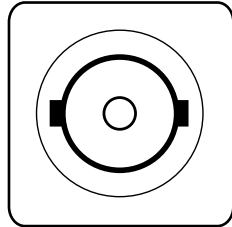

BNC connector: panel view (X111)

This connector is used to supply a 1 Vpp reference signal to the camera for genlocking when the optional encoder is fitted.

This connector can be used as an input socket for a 1 Vpp CVBS signal which is output on the TP out connector of the Base Station. This is only possible with Base Station LDK 4501 and when the optional encoder is fitted. Select the function of this socket in the camera Install menu or the Base Station System menu.

3.3.12 Tracker communications connector

Figure 3-22. Tracker communications connector

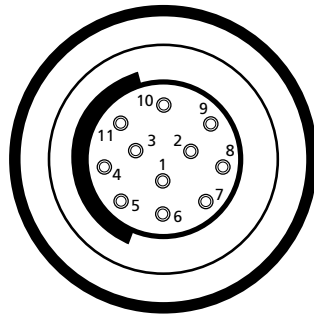

Fischer 11-pole female; panel view

Panel part number (X108): 3922 040 02463

1. On-air signal return
2. Tracker microphone return
3. Tracker microphone input
4. Production tracker
5. Sidetone/engineering tracker
6. Intercom return
7. Program sound tracker
8. Cameraman microphone
9. Tally control tracker (Cmos level, R out = 1k)
10. +12V; I max. = 100mA
11. +12V return

Microphone level: -58dBu/-20dBu switchable
Microphone impedance: 200 ohm

Telephone level: +6dBu
Telephone output impedance: <10 ohm

3.3.13 Auxiliary connector

Figure 3-23. Auxiliary connector

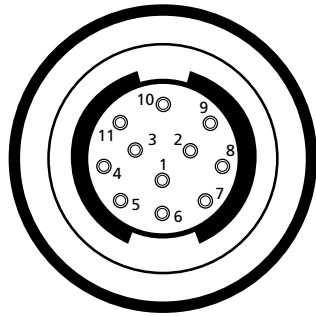

1. +5VL
2. OVL
3. AN0
4. AN1
5. Spare
6. On-air n.c.
7. Private Data Camera - Base Station
8. Ground
9. Private Data Base Station - Camera
10. Ground
11. Shield

Private data input signals: 0 < 0.8 Volt; 1 > 2.4 Volt
max. level: +/- 12 Volt
input impedance: > 100 kOhm
baud rate: 2400 bits/s nom; 4800 bits/s max.

Private data output signals: C-MOS levels 5V
output impedance: < 1 kOhm.

Analogue outputs (AN0 and AN1) output level: 0 - 5 Volt
output impedance: 100 Ohm

Fischer 11-pole female; panel view

Panel part number (X109): 3922 040 02512

Chapter 4

Operating instructions

This section shows the physical location of the controls on the camera. A description is given of how to navigate through the menu system and set-up your preferences.

Contents

Camera head controls	4-3
Viewfinder controls	4-4
Assigning functions to buttons	4-5
Using the camera.	4-6
Switching on the power	4-6
Controlling the camera.	4-6
Access and Security	4-7
Camera cards	4-7
Access control	4-8
Camera card slot	4-8
System Menu.	4-9
Entering the System menu	4-9
Finding your way	4-10
Leaving the System Menu.	4-10
Making changes.	4-11
Undoing changes	4-11
Viewfinder preferences	4-12
Viewfinder picture quality.	4-12
Video level indication	4-12
Tally indicators	4-12
Viewfinder markers	4-12
Lens preferences	4-13
Lens type	4-13
Auto iris	4-13
Extended Iris.	4-13
Lens indicators	4-13
Video preferences	4-14
Standard settings	4-14
Test signal	4-14
Gain selection.	4-15
Optical filter selection	4-15
Colour temperature selection	4-16
Exposure time.	4-18
Black stretch.	4-21
Auto skin contour.	4-21
Classic mode	4-22
Managing files.	4-22

Scene files	4-22
Operator files	4-23
Standard files	4-23
Customer standard files	4-23
User levels	4-23
Selecting the user level	4-24
Smart-Touch™	4-24
Triax adapter controls	4-26
Powering the camera	4-27
Selecting monitoring signals	4-27
Using audio	4-27
Intercom	4-28
Communication	4-29

4.1 Camera head controls

Figure 4-1. Camera head controls

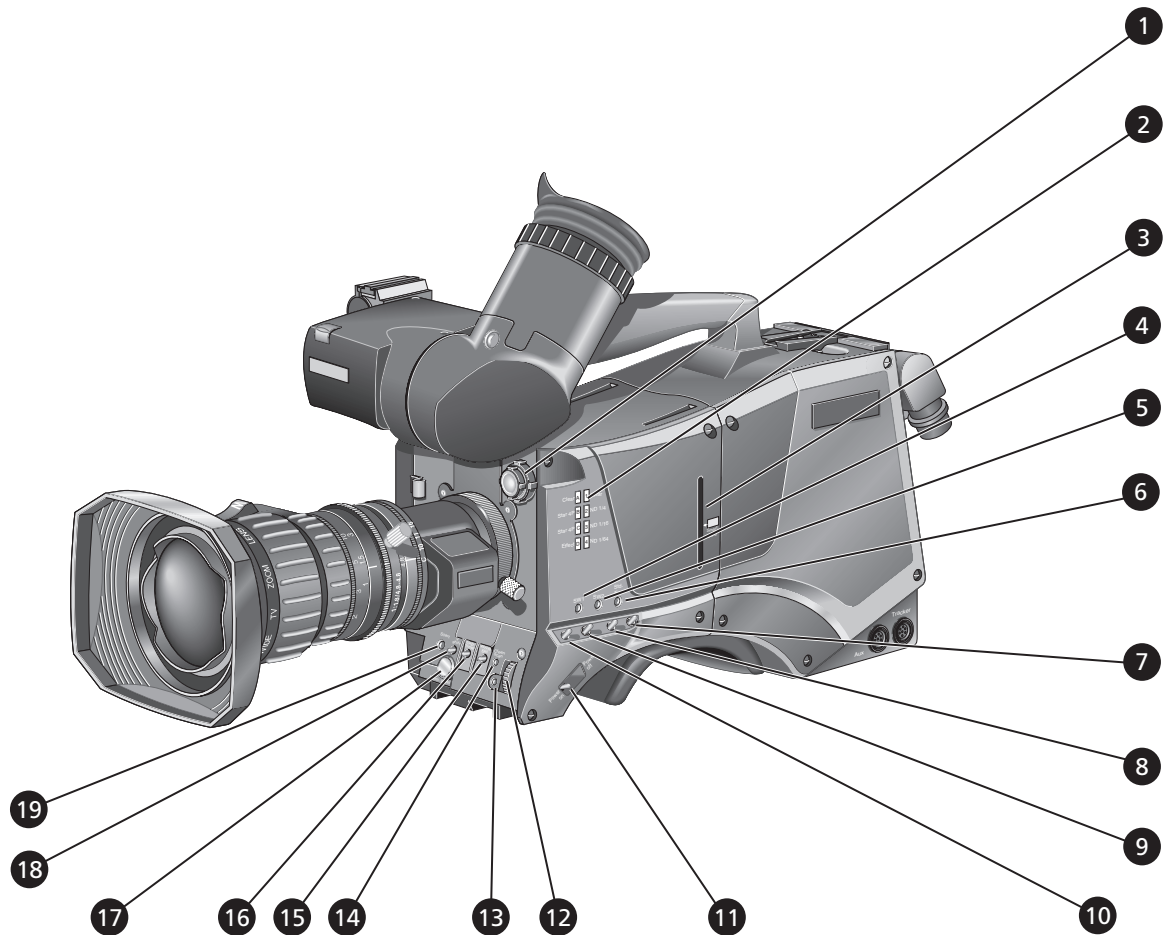

- | | |
|--------------------------------------------|-------------------------------------|
| 1. Filter wheel switches | 11. Power On/Off switch |
| 2. Filter wheel indicators | 12. Menu rotary control |
| 3. Camera card slot | 13. Menu select switch |
| 4. SW1 VTR Save (assignable button 1) | 14. Clean Scan button |
| 5. SW2 Extended Iris (assignable button 2) | 15. White balance switch |
| 6. Standard scene file button (Std.) | 16. Exposure time switch |
| 7. Black stretch switch | 17. Volume control (Audio Level) |
| 8. Colour temp. switch (White bal.) | 18. Vertical shift switch (V-Shift) |
| 9. Colour bars switch (Bars) | 19. VTR Start (assignable button 3) |
| 10. Gain selection switch | |

4.2 Viewfinder controls

Figure 4-2. Camera head controls

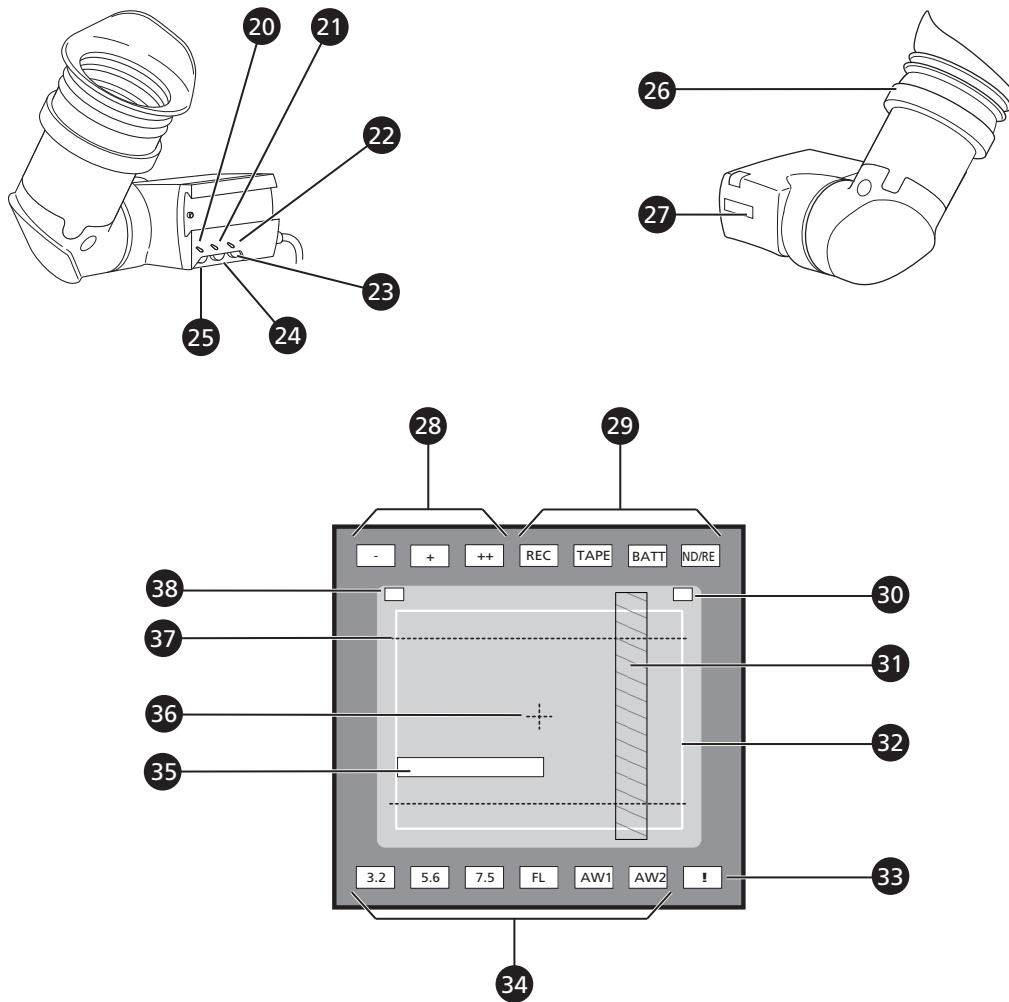

- | | |
|----------------------------------|-----------------------------------|
| 20. Tally switch | 30. Iris indication |
| 21. Zebra switch | 31. Zebra pattern |
| 22. Option (assignable switch 4) | 32. Safe area marker |
| 23. Brightness control | 33. Non-standard indicator |
| 24. Contrast control | 34. Colour temperature indicators |
| 25. Crispening control | 35. Message box |
| 26. Dioptre | 36. Centre marker |
| 27. Tally indicators (red) | 37. Cadre marker |
| 28. Gain indicators | 38. Zoom indication |
| 29. Top indicators | |

4.2.1 Assigning functions to buttons

The camera head has three assignable buttons, two on the side panel (4) and (5), and one on the lower front panel (19). The viewfinder has an assignable switch (22). These buttons can be assigned the following functions:

Table 4-1. Button Assignments

Switch	Assignment
VTR Save (4)	VTR Save
	Switch on external signal 1
	Switch on external signal 2
Ext. Iris (5)	Extended Iris
	Switch on external signal 1
	Switch on external signal 2
VTR Start (19)	VTR Start/Stop
	Switch on external signal 2
	Intercom
Option (22 on VF)	None
	Disable camera

The function and behaviour (momentary or alternating) of these buttons are set in the `INSTALL/BUTTONS` menu.

4.3 Using the camera

Attach lens, viewfinder, microphone and any other accessories to the camera. Attach the triax cable or supply the adapter with power.

4.3.1 Switching on the power

Triax adapter

1. On the Base Station set the master power switch to the ON position. The green power light lights.
2. Set the **Power switch** (11) of the camera to the **ON** position.



Note

The BATT indicator in the viewfinder lights if the camera supply voltage is less than 11V.

3. Allow a few moments for the camera to perform a self-test and for the system to establish communications.

4.3.2 Controlling the camera

There are several ways of controlling the camera:

- Using an OCP connected to the Base Station.
- Using the switches on the camera itself.
- Using the menu system to select functions.

The following paragraphs describe using the switches on the camera and the menu system.

4.4 Access and Security

4.4.1 Camera cards

Three camera cards are delivered with each camera. These comprise of two user's cards and one owner's card.

Figure 4-3. Camera cards

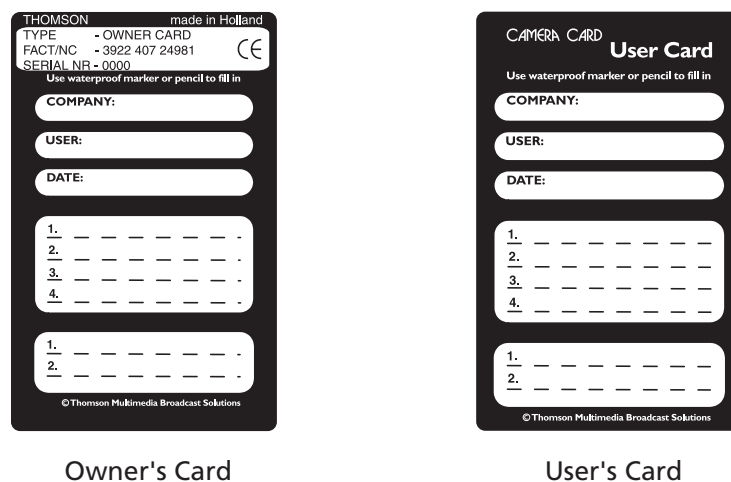

The owner's card has three functions:

- As an access control device to the security settings of the camera.
- As a storage device for four scene files.
- As a storage device for two operator files.

The owner's card is unique to every camera. Owner's card and camera must have the same serial number. An owner's card is linked to the serial number of the camera and cannot be used as an owner's card for another camera.

The user's card has two functions:

- As a storage device for four scene files.
- As a storage device for two operator files.

Scene files

Both the user's card and the owner's card allow four different scene files to be stored on the card. The recall and storage of a scene file is carried out via the Files menu of the menu system. A scene file contains information relating to the video settings.

Operator files

Both the user's card and the owner's card allow two different operator files to be stored on the card. The recall and storage of a operator file is carried out via the Files

menu of the menu system. An operator file contains information relating to the set-up of general camera preferences.

4.4.2 Access control

The owner's card or the PIN code is used to access special set-up and security features of the camera. Inserting the owner's card into the camera gives direct access to the Security menu. If you select the Security menu without this card inserted, you must enter the correct PIN code to gain access to this menu.

PIN code

The PIN code of the camera can be viewed and changed in the Security menu. The camera's PIN code when it leaves the factory is set to 0000. It is strongly advised that this code be changed by the owner on receipt of the camera. This ensures added protection against unauthorised access to the Security menu.

4.4.3 Camera card slot

Insert your camera card into this slot with the chip on the card facing the front of the camera. Push the card home until it fits snugly. A camera card is not required for normal operation of the camera.

Figure 4-4. Camera card slot

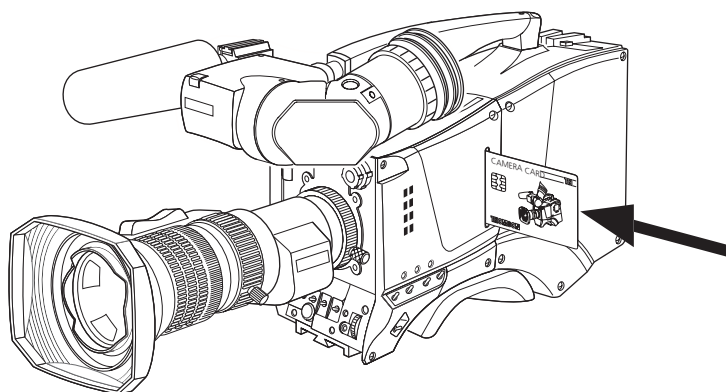

Note

Only use an original camera card. Store the owner's card in a safe place.

4.5 System Menu

The camera is operated via the viewfinder text display and the control system menu switches. The systems menu is viewed in the viewfinder and navigated by means of the **Rotary control** (12) and the **Select button** (13) which are both located at the front of the camera.

The functions of the camera are grouped into menus and sub-menus. There are eight different menus that are listed in the main menu as follows:

VF	>>
Lens	>>
Video	>>
Install	>>
Files	>>
Security	>>
Diagnostics	>>

Each of these menus gives you access to a particular group of functions. Spend some time using the controls and menus to discover the various functions. You will quickly learn to operate the camera intuitively .



Note

Some of the menu items may not appear if the user level is not set to 3.

4.5.1 Entering the System menu

Press the **Select** button (13) after the camera is switched on, the message Menu off appears in the viewfinder. Press the **Select** button again while this text is showing, the **MAIN** menu appears in the viewfinder.

Figure 4-5. Main menu

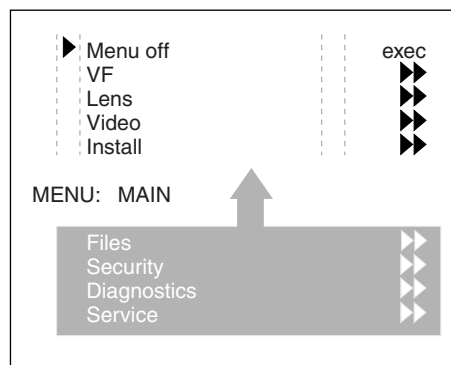

The **MAIN** menu screen shows five items. The name of the menu is shown below these. Four more items are hidden but become visible when you scroll down using the **Rotary control** (12). A cursor shows your position in the menu. The **Rotary control** moves the cursor up and down.

4.5.2 Finding your way

Use the **Rotary control** (12) to move the cursor through the menu items. If a double arrow (>>) is visible, then pressing the **Select button** (13) brings you one level lower in the menu system. Only five items are visible in each menu. Scroll up or down to see any additional items. When you first enter a menu (other than the **MAIN** menu) the cursor is positioned next to the first item.

The **TOP** and **PREVIOUS** entries are not immediately visible but are located above the first item. Use the **Rotary control** to scroll up to them.

- Select **TOP** to bring you back to the **MAIN** menu.
- Select **PREVIOUS** to go back to the menu that you were in before the current one.

The **LENS** menu, for example, shows the items displayed when you first enter the menu and the other items that are available by scrolling up or down with the **Rotary control**.

Figure 4-6. Lens menu

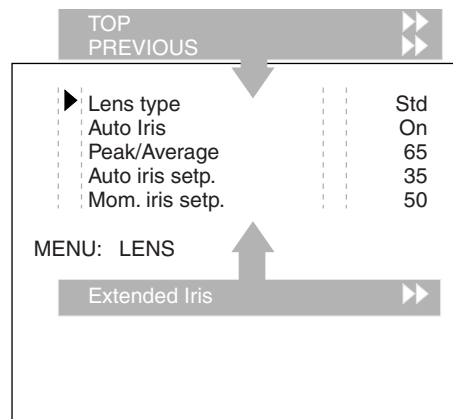

4.5.3 Leaving the System Menu

If you are deep within the menu structure, the recommended way of leaving the System menu is:

1. If necessary move the cursor to the left column with the **Select button** (13).
2. Scroll upwards with the **Rotary control** (12) until the cursor points to **TOP** (this is the **MAIN** menu).
3. Press the **Select button**. The cursor now points to the **MENU OFF** item of the **MAIN** menu.
4. Press the **Select button** to leave the System menu.

If you do not use the menu it disappears after a few seconds. (This delay can be programmed in the ∇F menu.) However, when you press the **Select button** again you enter the System menu at the last position of the cursor and not at the top of **MAIN** menu. To prevent confusion the next time you enter the System menu, it is advisable to leave the menu by returning to the **MAIN** menu (**TOP**) and selecting **MENU OFF**.

4.5.4 Making changes

To find out where you have to go to change a function, consult the appendix to discover under which menu group or sub-group the function you want to change is located. If the cursor points to an item (and there are no double arrows to indicate a sub-menu) then the item pointed to has a value. The value can be:

- a toggle value (only two values)
- a list value (more than two values)
- an analogue value (variable from 00 to 99)
- unavailable (---).

If the value is unavailable it cannot be changed. This is indicated by three dashes (---). This can occur, for example, when a function is switched off. The analogue values associated with that function are then unavailable.

If there are only two values associated with the function, then pressing the **Select button** (13) toggles between these two values. If a value is displayed next to a function that is one of several possible values, then pressing the **Select button** places the cursor in a list menu indicating the value currently selected. Use the **Rotary control** (12) to point to a new value. Press the **Select button** to return the cursor to the function list.

If an analogue value is displayed next to a function name, then pressing the **Select button** places the cursor in front of the value and the **Rotary control** is used to change the analogue value. Press the **Select button** to return the cursor to the function list.

4.5.5 Undoing changes

If you make changes to the video settings in the Systems menu and you decide not to keep them, use the **Std. button** (6) at the side of the camera to recall a standard set of values for the video parameters.

4.6 Viewfinder preferences

Set up the viewfinder according to your own preferences; adjust viewing parameters, select markers, message boxes and on-screen display times.

4.6.1 Viewfinder picture quality

Adjust the **Brightness** (23) and **Contrast** (24) controls according to your preferences. If you wish, use the **Crispeneing (peaking) control** (25) to adjust the sharpness of the viewfinder picture (reduce the crispeneing when the gain is set to +++).

The dioptre of the viewfinder can be adjusted to suit your eyesight by turning the **Dioptre ring** (26). The range of the dioptre is +1 to -3.

4.6.2 Video level indication

Switch on the zebra function so that you are alerted in the viewfinder by a **Zebra pattern** (31) in areas where high video levels occur. This diagonal line pattern warns you that the area affected has risen above a predetermined level of the full scale video exposure value. Go to the $\vee\text{F}$ menu to set the video levels at which the zebra function works.

4.6.3 Tally indicators

The red **Tally indicators** (27) at the front of the viewfinder and at the rear of the carrying handle light to indicate that the camera is on-air.

The **Tally switch** (20) is used to control the Tally indicator at the front of the viewfinder. When this switch is set to the **OFF** position, the **Tally indicator** does not light when the camera is on-air. The **Tally switch** does not control the tally indicator at the rear of the carrying handle.

When the camera is on-air, the **REC indicator** (29) in the viewfinder lights. When the studio ISO signal is received, the **TAPE indicator** (29) lights.

4.6.4 Viewfinder markers

Go to the $\vee\text{F}$ menu to select the markers you wish to see in the viewfinder. The following markers can be set up:

- The **Safe area marker** (32) indicates an area that represents 80% of the whole viewfinder picture area. This is the minimum area seen on a TV-set.
 - The **Message box** (35) displays information messages. The length of time this box remains on the screen is set by the Info time item of the $\vee\text{F}$ menu.
 - The **Centre marker cross** (36) marks the centre of the picture.
 - The **Cadre marker** (37) is a dotted white line or a shaded area that shows the limits of a 16:9 picture.
-

4.7 Lens preferences

When you fit a lens to the camera you may need to adjust the back focus. Refer to the lens manufacturer's instructions to find out how to do this. The **LENS** menu allows you to choose and, if necessary, adjust parameters to suit your lens type and your personal preferences.

4.7.1 Lens type

In the **LENS** menu select the lens type from two predefined settings; standard (**Std**) or wide angle (**WA**). This gives you the optimum shading settings for either a standard or wide angle lens. The lens manufacturer is also selected in this menu.

4.7.2 Auto iris

If required switch on the auto iris function in the **LENS** menu. You can also select the parameters associated with the auto and the momentary iris in this menu.

4.7.3 Extended Iris

The extended iris function automatically regulates the video signal level by adjusting the iris opening, the gain level and the exposure time to suit the ambient lighting conditions.

To switch on the extended iris function use the **Extended iris button** (5) at the left-front side of the camera. When this button is pressed once, the current value of the automatic extended iris function is displayed. Press the button twice in quick succession to switch between on and off.

When extended iris is on, the **Non-standard indicator** (33) in the viewfinder lights, and gain and exposure controls are blocked. The parameters for the extended iris function are set in the **LENS** menu.

4.7.4 Lens indicators

The **ND/RE indicator** (29) in the viewfinder lights when a lens range extender is selected.

The **Iris indication** (30) in the viewfinder shows the value of the iris opening (when enabled in the **VF** menu).

The **Zoom indicator** (38) in the viewfinder shows the degree to which the lens has been zoomed in or out if this feature is supported by the lens. It shows 50 if not supported.

4.8 Video preferences

The means used to control the camera depends on your work methods. A remote OCP can be used and a low user level can be selected to restrict the available camera functions. Alternatively, video functions can be controlled on the camera itself. The following functions are available on the camera:

- Standard settings
- Test signal
- Gain selection
- Optical filter selection
- Colour temperature
- Auto-white balance
- Exposure time
- Black stretch
- Auto skin contour

Many other video functions such as contour, black, gain, knee, gamma, matrix and white limit functions are available in the VIDEO menu.

4.8.1 Standard settings

To ensure that some of the camera functions are not set to unusual values, a standard file has been defined that contains the default values for most video functions. The table in the Appendix lists the values that are set when the standard file is recalled.

To recall the standard values for the various video functions, press the green **STD button** (6) on the left-front side of the camera and hold it for two seconds. The standard values only take effect when the camera is not on-air.

The standard file can be selected as either a factory or a customer standard file. Changing the standard file can only be done in the System security menu if the owner card or the PIN code is used.

The **Non-standard indicator** (33) lights when the video settings are not set to their standard value, for example, when exposure is not set to nominal. It also lights when black stretch or extended iris is on and if AWC or FL is selected with the colour temperature selector.

4.8.2 Test signal

The left-front side panel of the camera has a **Colour bar switch** (9) for switching on a colour bar test signal. The colour bar is the standard test signal that is used to set up and check the camera before use.

When the colour bar is selected the following functions are temporarily set to **Off**:

- Black stretch
 - White limiter
 - Zebra
-

- Safe area (VF)
- Cadre (VF)

The lens iris closes automatically when the colour bars are switched on.

4.8.3 Gain selection

Depending on the available light levels it may be necessary to adjust the gain of the camera. The gain is selected via the up/down scroll **Gain switch** (10) on the left-front side of the camera. When this switch is pressed initially, the current value of the gain in dB is displayed in the viewfinder.

The up/down scroll **Gain switch** (10) gives a choice of five master gain settings: -, 0, +, ++ and +++. The actual value of the gain in dB is assigned to these symbols in the **INSTALL** menu.

Table 4-2. Gain values

Symbol		Gain
-	can be set to:	-6dB or -3dB
0	is always	0dB.
+	can be set to:	6, 9, 12 or 18dB
++	can be set to:	9, 12, 18 or 24dB
+++	can be set to:	30 or 36dB (or 42dB IT/ITW)

The **Gain indicators** (28) in the viewfinder light to indicate the value selected. (The + and ++ indicators light when the gain is +++)

4.8.4 Optical filter selection

A neutral density filter and a special effect filter can be placed in the path of the optical signal to modify the incoming light. The filters are selected via the **Filter switches** (1) at the top-front of the camera. These filters can be used, for example, to control depth of field or exposure levels.



Note

Some camera versions only have the neutral density filterwheel.

The camera does not need colour optical filters to be able to white balance correctly. The range of the auto-white balance is so wide (from 2.5K to 20K) that there is never any need to use colour filters to obtain the correct white. Rotate the switches to move the optical filter wheels.

The outer (bigger) filter switch has four positions:

Table 4-3. Filter wheel 1 values

Position	Filter
1	Clear
2	ND 1/4 filter (2 stops)
3	ND 1/16 filter (4 stops)
4	ND 1/64 filter (6 stops)

The inner (smaller) filter switch also has four positions:

Table 4-4. Filter wheel 2 values

Position	Filter
1	Clear
2	4-point star
3	6-point star
4	Soft focus

The status of the filter wheels is displayed in the viewfinder for a few seconds. The **ND/RE indicator** (29) in the viewfinder lights when an ND (Neutral Density) filter is selected.

4.8.5 Colour temperature selection

For true colour reproduction the ambient lighting conditions must be compensated for by selecting a value for the colour temperature. The standard file setting is 3200K (normally used for tungsten light). Two other reference colour temperatures are available; 5600K (for outdoors, clouded conditions) and 7500K (for outdoors, clear blue skies).

Three memory positions (FL, AW1 and AW2) are available to store the results of the auto-white measurement process. The memory positions are filled with measured values using the automatic white balance switch at the front. The FL position is recommended for shooting with fluorescent light.

A continuous automatic white balance position (AWC) is also available. This function continuously measures the white balance and adjusts accordingly. It can be used when a constant colour balance is required under changing lighting temperatures (sunsets, indoors/outdoors use).

In the auto-white positions an electronic colour filter can be adjusted in the VIDEO menu. This varies the colour balance to obtain warmer or colder colour effects. When an automatic white balance process is performed, the electronic colour filter is reset to its default value.

Selecting the colour temperature

The up/down **Colour temperature (White bal.) switch** (8) on the left-front side of the camera allows a choice between:

Three preset colour temperatures:

- 3200K (3.2K) - for studio lighting conditions
- 5600K (5.6K) - for outdoors, clouded conditions
- 7500K (7.5K) - for outdoors, clear blue skies

Three memory positions:

- FL- memory position for fluorescent light
- AW1 - memory position 1
- AW2 - memory position 2

An automatic continuous white position:

- AWC - continuous measurement (2.5K to 20K)

When the switch is first pressed, the viewfinder displays the current value. A new value is chosen by scrolling up or down through the available values. The **Colour temperature indicators** (34) in the viewfinder light to show which position is selected. None of these indicators light when AWC is selected, but the **Non-standard indicator** (33) lights.

The viewfinder also displays the actual value of a measured colour temperature. The range of the auto-white balance is from 2.5K to 20K.

Auto-white balance

If the reference colour temperatures do not match your lighting conditions carry out the auto-white procedure as follows:

1. Use the **Colour temperature switch** (8) to select one of the memory positions FL, AW1 or AW2 in which to store the measured colour temperature value.
2. Press once on the **White balance switch** (15) at the front of the camera to start the automatic white balance procedure. The following appears in the viewfinder:

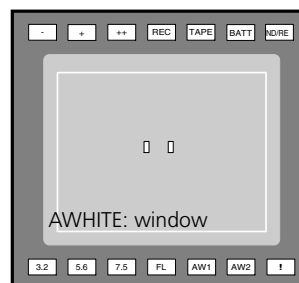

3. Point the camera so that the reference white surface is between the two small white boxes.

4. Press the **White balance switch** (15) again to start the measurement procedure. A message indicating that the process is running appears.

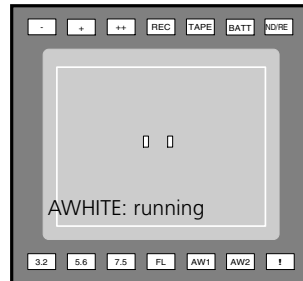

5. When the process is completed (within a few seconds) the **OK** message and the measured temperature appear in the viewfinder.



The measured colour temperature is now stored in the selected memory position and can be recalled as required.



Note

During the auto-white measurement process iris is set to Auto and 90% and the knee is turned off.

Black balance is not necessary with this camera because of the continuous automatic black control circuits.

4.8.6 Exposure time

The exposure time values of 1/200, 1/500 and 1/1000 of a second are used to capture fast moving objects so that these can be played back sharply in slow motion. The value selected depends on the speed of the moving object.



Note

Increasing the exposure speed lowers the camera sensitivity proportionally.

Selecting the exposure time

The momentary up/down **Exposure time switch** (16) gives a choice of exposure time settings.

Table 4-5. Exposure time values

Value	Function
Nom.	- nominal setting
Var.	- enables the exposure to be varied
CRT	- for shooting sync-locked monitors
Film	- to vary the exposure with running shutter
1/200	- for fast moving objects
1/500	- for fast moving objects
1/1000	- for fast moving objects
1/2000	- only with IT and ITW versions
EVR	- extended vertical resolution (IT only)
50 Hz	- shooting with 50Hz lighting (adjustable)
60 Hz	- shooting with 60Hz lighting (adjustable)

If an exposure time other than nominal is selected, the **Non-standard indicator** (33) in the viewfinder lights.

Film

The **Film** function is a variable exposure function with running shutter. The **Clean scan** range is wider but with the Film function highlights do not cause a smear effect. If the **Film** function is selected the exposure time can be set in the **VF** menu.

Lighting

The exposure selection also includes lighting control positions which can be used when shooting with lighting that is operating at a different frequency to the camera. There are two positions; 50 Hz and 60 Hz. Each of these positions can be varied further in a range from -10 to +10. To reduce flicker select the frequency closest to the frequency of the lights and then vary the lighting control in the **INSTALL** menu to obtain the best result.

Shooting screens

Sometimes when shooting TVs or computer monitors a horizontal bar can be seen across these screens in the viewfinder. There are two ways of removing the noise bar from the picture depending on the frame frequency of the display:

- For displays with the same frame frequency as the camera, for example TV sets, use the V-shift facility.
- For displays with a higher frame frequency, for example computer monitors, use the Clean Scan facility.

Vertical shift (V-Shift)

Sometimes when shooting TV screens or monitors with the same display frequency as the camera, for example TV sets, a horizontal black bar is seen in the viewfinder because the camera is blanking while the TV is not. The **V-Shift switch** (18) shifts the camera blanking.

The **V-Shift switch** (18) at the front of the camera is spring-loaded with a central rest position. Holding the switch in the + or - position moves the bar up or down so that it is no longer visible in the viewfinder. This function is only available when the camera is used in the stand-alone mode and is not active when the camera is genlocked or on-air.

Clean scan

When shooting computer monitors with higher frame frequencies than the camera use the Clean Scan function to avoid horizontal bars in the picture.

Carry out the Clean Scan function as follows:

1. Press the **Clean Scan button** (14) at the front of the camera for about two seconds to directly access the variable exposure (clean scan) function. The **CLEAN SCAN** submenu appears in the viewfinder.
2. Use the **Rotary control** (12) to change the value and so remove the noise bar.
3. If a more accurate adjustment is required set the **CL. SCAN** item to **EXTENDED**. (Set the mode to **NORMAL** if a smear effect occurs.)
4. Set the **UNIT** item to the preferred read out, **Hz** or **mSec**.

When you are finished shooting the monitor press the **Clean Scan button** (14) for two seconds to switch off the Clean Scan function. (Exposure time returns to its previous non-variable setting.)



Note

Do not shoot highlights in the Clean Scan mode as this may cause a smear effect.

The Clean Scan function cannot be used with IT cameras.

When the Clean Scan function is on, the **Non-standard indicator** (33) in the viewfinder lights.

CRT exposure

A third possibility can arise when shooting a monitor whose synchronisation is locked to the camera's. Stripes might be visible in the monitor picture. (This is more usual with 16:9 cameras.) To remove these disturbing line pairing effects between monitor and camera lines, select the CRT option with the **Exposure time switch** (16).

4.8.7 Black stretch

The black stretch function gives more detail in the dark areas of the picture without effecting the rest of the picture. Set the **Black stretch switch** (7) to the **On** position to switch on the black stretch function.

When black stretch is switched on the **Non-standard indicator** (33) in the viewfinder lights. The Video menu allows you to adjust the black stretch parameters.

4.8.8 Auto skin contour

Use skin contour to change the contour level in a selected colour range. Decreasing the contour level of a persons skin colour softens only the skin tones. But not only skin colours can be selected, for example, decrease the contour level of a soccer field to accentuate the soccer players or increase the skin contour level to accentuate a rough surface.

Carry out the Auto skin contour procedure as follows:

1. In the VIDEO\SKIN\SKIN menu, select the memory position skin 1 or 2 (not 1+2).



2. Place the cursor in front of the VIDEO\SKIN\AUTO item.

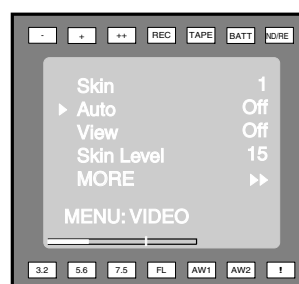

3. Press the **Select button** (13). The following appears in the viewfinder.

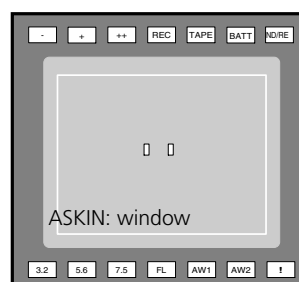

4. Point two small white boxes at the intended surface.
5. Press the **Select button** (13) to start the measurement procedure (the iris is set to Auto). The process running message appears:

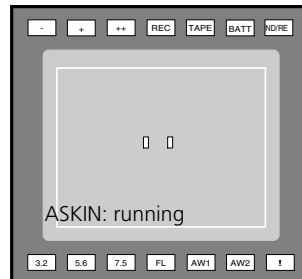

6. When the process is completed (within a few seconds) the **OK** message appears in the viewfinder.
7. Adjust the skin contour level with the `VIDEO\SKIN\SKIN LEVEL` item. Decrease the value below 50 to soften the selected area. Increase the value above 50 to add extra contour.

Repeat the steps for the other memory position if required. Both skin contour settings can be used at the same time. Set the menu item `VIDEO\SKIN\VIEW` to on to indicate the effected area.

4.8.9 Classic mode

The `VIDEO` menu allows you to adjust many parameters for setting up detail (contours) and gamma. If you wish the contour and gamma controls to be the same as in previous cameras (LDK 100 or LDK 200), then switch to the Classic mode in the Install menu.

4.9 Managing files

You can have access to 15 different files. This number can be extended by using additional scene file camera cards. The Files menu is used to recall and store these files. There are two types of file:

- scene files
- operator files

A scene file contains values related to the picture performance. The operator file contains values related to the set-up of the camera (viewfinder, lens and installation parameters). The tables in the Appendix indicate the functions that are stored in the scene file and those functions that are stored in an operator file.

4.9.1 Scene files

Four scene files are stored in the camera itself (SCAM1, SCAM2, SCAM3 and SCAM4). Another four scene files can be stored on the camera card (SCARD1, SCARD2, SCARD3 and SCARD4). A STANDARD scene file (preselected as either factory or customer defined) is stored in the camera.

**Note**

The standard customer scene file is stored via the **SECURITY** menu, not the **FILES** menu. The decision to use the factory defined file or the customer defined file as the standard file is also made in this menu.

The **FILES** menu enables the scene files to be stored and recalled using the store and recall entries of the menu system. If the message **NOK** is displayed, then the old values are restored. If the camera is on-air when a scene file is recalled, then the recalled values do not become active until the camera goes off air.

4.9.2 Operator files

The **FILES** menu also allows the recall of the operator file stored in the camera (OCAM1) or one of the two operator files (OCARD1 and OCARD2) stored on the camera card. These files contain information for setting up the non-video configuration of the camera. A **STANDARD** operator files (factory or customer defined) is stored in the camera.

**Note**

The standard customer operator file is stored via the **SECURITY** menu, not the **FILES** menu. The decision to use the factory defined file or the customer defined file as the standard file is also made in this menu.

4.9.3 Standard files

The green **STD button** (6) on the left-front side of the camera recalls the standard scene file. This file contains standard parameters for the picture performance. A standard operator's file can be recalled via the **FILES** menu. This file contains parameters for the set-up of the camera.

4.9.4 Customer standard files

You can define a customer standard file for the standard scene file and for the standard operator's file. The contents of the customer files for both these standard files is stored via the **SECURITY** menu. The selection of a factory defined or a customer defined file for use as a standard file is also made in this menu. You can only access the functions of the **SECURITY** menu with an owner's card or the PIN code of the camera.

4.10 User levels

The user level function in the **SECURITY** menu restricts access, in varying degrees, to the operational controls of the camera. You can only access the functions of the **SECURITY** menu with an owner's card or the PIN code of the camera.

4.10.1 Selecting the user level

There are four user levels: user0, user1, user2 and user3. The purpose of the user levels is to restrict the set of functions which can be changed by whoever is using the camera. In this way a more centralized and uniform control can be achieved and the danger of the camera operator accidentally changing critical functions while shooting is reduced.

User level 0 is a special protection level which locks most of the operational controls of the camera. Use this level to ensure that a camera that has been set-up is not tampered with. User level 0 is not normally used for operational purposes as it is too restrictive for normal circumstances. The recommended minimum user level is 1. For full control set the level to 3. When you switch off the power, the access rights that were obtained by the use of the PIN code are disabled and the camera starts at the assigned user level when switched on again.

Disable camera

The disable camera function is a protection function which prevents unauthorised interference with the camera and provides an additional level of security. Setting disable camera to **ON** is similar to using User level 0 to protect the settings of the camera. (The **Option switch** on the 1.5-inch viewfinder can be assigned this function in the Install menu.)

4.11 Smart-Touch™

Smart-Touch is an optional software module that gives immediate access to 14 pre-defined scene files. This library allows you to quickly set up the camera for different shooting conditions.

To choose a particular file proceed as follows:

1. Press the green **STD button** for 2 seconds; the viewfinder shows the library of available shooting conditions.
2. Select a file by turning the **Rotary control** at the front of the camera.
3. Activate the file of your choice by pressing the **Select button** at the front of the camera.

The new values only take effect when the camera is not on-air. The Smart-Touch files can also be selected by navigating to the **FILES** menu using the System Menu. The files of the Smart-Touch library are divided into three categories, Lighting, Creative, and Matching, which complement the standard setting scene file.

The Lighting category provides three different files for various lighting conditions:

- **Night** optimises the transfer characteristic to enhance the visibility of detail in very dark scenes without the undesirable consequence of excessive noise associated with simply increasing gain.
 - **Fluorescent** establishes matrix and colourmetric parameters to reduce the green tinge and give a more acceptable picture when the scene is lit with uncorrected fluorescent lighting.
-

- **Extreme contrast** uses the full dynamic range of the FT CCD sensor to obtain better handling of highlights and more detail in the shadows.

The Creative category provides seven files for different effects:

- **Sports warm colour** delivers warm and rich contrasts bringing out team colours.
- **Sports interview** incorporates the dual skin tone control into the sports setting for interviews.
- **HI film** gives a high contrast film-like look which is ideal for outdoor location production.
- **HI film + skin** is the HI film setting with dual skin tone control incorporated for natural, flattering close-ups.
- **LO film** gives a low contrast film-like look for studio production.
- **LO film + skin** is the LO film setting with dual skin tone control incorporated for natural, flattering close-ups.
- **Sepia** creates a sepia tone look for atmosphere-rich production.

The Matching category provides three files for camera matching:

- **LDK 9x + LDK 10** for matching to Philips LDK 9, LDK 10, LDK 90 and LDK 91 cameras.
- **DVW xxx** for matching to Sony cameras.
- **HL xxx** for matching to Ikegami cameras.

Each of these settings can be personalised and stored on a smart card.

4.12 Triax adapter controls

Figure 4-7. Triax adapter LDK 5430 controls

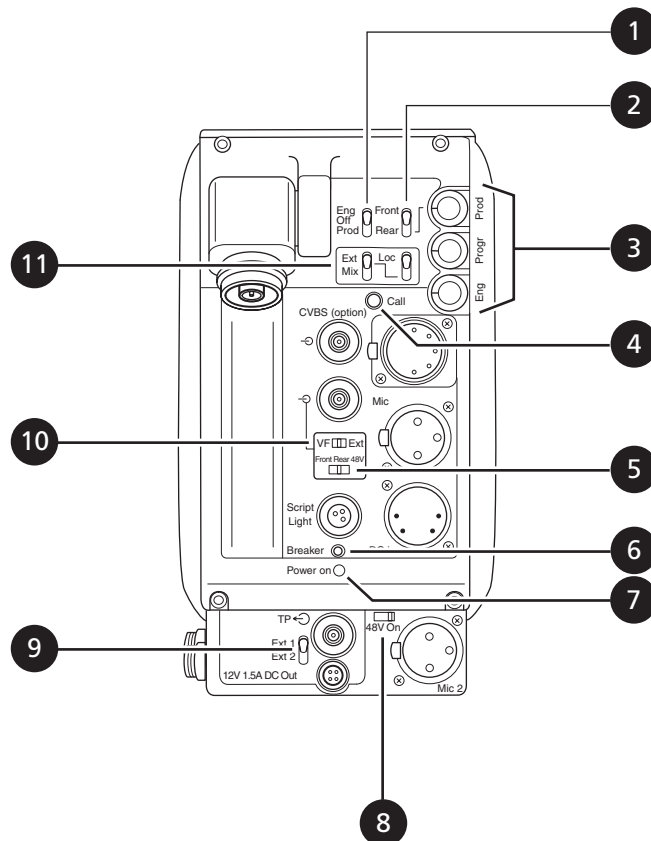

- | | |
|----------------------------------------------|--------------------------------------|
| 1. Intercom routing switch | 7. Circuit breaker button (BREAKER) |
| 2. Headset production vol. control selection | 8. Microphone 2 phantom power switch |
| 3. Headset volume controls | 9. External signal selection |
| 4. Call button | 10. Viewfinder display signal |
| 5. Audio microphone switch | 11. Video output selection switch |
| 6. Power on indicator | |

4.12.1 Powering the camera

The power supply for the camera and Triax adapter is normally supplied via the triax cable from the Base Station. The power on indicator (6) lights when power is supplied and the camera power switch is On.

If excessive current flows in the camera or adapter, the circuit breaker (7) trips and shuts off power to all the units. If this happens check the units for faults and if necessary take corrective action before pressing the circuit breaker button to reset the power.

It is also possible to operate the camera without a triax cable by supplying a +12 Vdc supply to the DC input socket.

When power is supplied via the triax cable, an output power socket supplies +12 Vdc, 1.5A maximum for powering accessories.

4.12.2 Selecting monitoring signals

Viewfinder display signal

The viewfinder can display local or external video signals. Two switches (11) determine the signal that is displayed in the viewfinder.

Set the first switch to LOC to display the local camera Y signal in the viewfinder. (The Ret. button on the lens also selects this signal in parallel with this switch.) If set to the other position, then the second switch determines the signal displayed in the viewfinder.

The second switch selects the signal displayed in the viewfinder when the viewfinder signal selection switch is not in the LOC position. The signal then displayed is:

- EXT Base Station external input 1 or 2.
- MIX Base Station external input 1 or 2 and camera Y signal mixed.

External signal selection

The External signal selection switch (9) selects either the EXT1 or EXT 2 signal from the Base Station.

In addition to this switch, other switches on the camera (VTR start) can be set up in the Install menu to switch this function.

Output monitoring signal

The monitoring output selection switch (10) determines whether the viewfinder signal from the camera or the external video signal from the Base Station is available at the output connector .

4.12.3 Using audio

Two high quality audio channels are available in the triax mode. Set the gain levels (-22 to -64 dB) for these channels in the Audio section of the Install menu. A high-pass filter for each channel can also be switched on via this menu.

Audio channel 1

The microphone for channel 1 is connected either to the socket at the front-right of the camera or to the Mic 1 socket on the triax adapter. A 3-position switch (5) activates the socket at the front-right or the connector at the rear. The third position selects the rear socket with a phantom power supply (48V).

Audio channel 2

The microphone for the second audio channel is connected to the Mic 2 socket on the triax adapter. A 2-position switch (8) selects a phantom power supply (48V) for the second audio microphone.

4.12.4 Intercom

Three intercom channels – production (Prod), program sound (Prog) and engineering (Eng) – are sent from the Base Station to the camera operator's headset. The camera operator's intercom microphone signal is sent to the Base Station. A tracker can also connect a headset to the intercom system to receive all of the channels from the Base Station and the camera operator's microphone signal as well. The tracker's microphone signal is passed to the camera operator and to the Base Station.

The Intercom section of the Install menu contains various settings for all these channels. Signals for left and right headset muffs and sidetone levels can be selected. Intercom microphone amplification levels, phantom power supply and microphone on/off switches are also available in this menu.

Additional controls are found on the back of the adapter.

Intercom microphone routing switch

This 3-position switch (1) routes the camera operator's intercom microphone signal to engineering (Eng) or production (Prod), or turns off the intercom. Use the VTR Start button at the front of the camera, or the VTR button on the lens, to send the camera operator's intercom microphone signal to production, regardless of the position of this switch.

Production volume control selection

Use this 2-position switch (2) to control the volume of the production signal in the intercom either at the front of the camera or at the rear of the adapter.

Intercom headset volume controls

- Prod - adjusts the volume of the production signal to the camera operator's headset when selection switch (2) is in the REAR position.
 - Prog - adjusts the volume of the programme signal to the camera operator's headset.
 - Eng - adjusts the volume of the engineering intercom signal to the camera operator's headset.
-

4.12.5 Communication

Call button

Press this momentary button (4) to send a signal to the control panels calling for attention. The ND/RE indicator in the 1.5-inch viewfinder shows when a call signal is sent or received.

Data channel

The Aux connector on the side of the adapter provides analogue control signals and facilities for the connection of a two-way private data channel between camera and Base Station. In the Install menu, the tracker microphone and engineering intercom channels can be selected to carry the private data instead of their normal function.

On-air signal

The tracker connector on the side of the adapter, as well as providing full intercom facilities for the dolly or crane driver, also carries a tally signal and a +12 Vdc power supply. This allows an external on-air lamp to be used.



Chapter 5

Menu structure

This section shows the menu structure and lists the location of the functions in the menus.

Contents

Menu structure	5-2
Main (top) menu	5-2
Where to find a function	5-6



5.1 Menu structure

5.1.1 Main (top) menu

The top menu gives access to the following submenus:

Viewfinder (VF) menu

This menu contains the functions which determine how items in the viewfinder are displayed.

Lens menu

The functions contained under this menu control various aspects of the lens.

Video menu

This menu contains those functions which affect the picture quality.

Install menu

This menu contains the functions that are used to set up the general configuration of the camera. It also contains controls to customize those switches that are directly operated on the camera.

Files menu

This menu allows values to be stored in scene and operator files, and allows these files to be recalled as required.

Security menu

The security menu is used by the camera owner to set user levels and to control access to the camera, or to store the customer (scene and operator) default files.

Diagnostic menu

The diagnostic menu provides information on the current status of the camera. No values can be changed in this menu.

The main functions available in these menus are shown in the following tables. The functions available depend on user level and camera configuration.

Table 5-1. Viewfinder menu

Main menu items	Purpose
VF mon	video signal in viewfinder
VF Contour	contours in viewfinder signal
Zebra	overexposure indication
Centre Cross	indication on or off
Safe Area	indication on or off
Audio Bar	indicator on or off
Iris Indicator	on/off
Focus Indicator	on/off
Zoom Indicator	on/off
Box downright	information box
4:3 Area	aspect ratio guides
Indicator White	display text intensity
Indicator Black	display text contrast
Display	viewfinder display duration
Menu Time	menu display duration
Info Time	information display duration
Rotary Speed	rotary control sensitivity
Box downleft	information box SuperXpander

Table 5-2. Lens menu items

Main menu items	Purpose
Lens Type	standard or wide angle lens
Auto Iris	on/off
Peak/Average	auto iris values
Auto Iris Setpoint	auto iris setpoint value
Mom. Iris Setpoint	momentary iris setpoint value
Manufacturer	Angenieux, Canon, Fuji, other
RE iris comp.	set range extender iris compensation on or off
Extended iris	gain, exposure, iris values
VTR Switch	select toggle or momentary
Handgrip zoom	select speed and curve for zoom control

Table 5-3. Video menu

Main menu items	Purpose
Colour filter	adjust filter level
Detail level	set detail level
Skin	set skin contour values
Flare	set flare values
Black	set values for black functions
Gain	set values for R, G, B gain
Knee	set knee values
Gamma	set gamma values
Matrix	select matrix type and value
White Limit	set white limiter values
Shading	set white shading values

Table 5-4. Install menu (Triax camera)

Main menu items	Purpose
Disable Camera	on/off
IR receiver	on/off
OnAir Lamp	on/off
Intercom	set intercom values
Audio	set gain and filter
Timing	set subcarrier and h-phase
Notch	on/off
Chroma	on/off
Aspect ratio	select aspect ratio values
Exposure	set lighting and clear scan values
Gain preset	set gain preset values
Autowhite	set autowhite speed and gain
Quick Smart Touch	on/off
Private Data	select data for intercom channels
Heater	on/off switch for SuperXpander heater
Classic Mode	set on for classic control
Buttons	assign functions to buttons

Table 5-5. Files menu

Main menu items	Purpose
Store scenefile	select and store scene file
Recall scenefile	select and recall scene file
Store oper. file	select and store operator file
Recall oper. file	select and recall operator file
Attributes	set name and read/write value
Standard files	recall standard files

Table 5-6. Security menu

Main menu items	Purpose
Installed Level	set user level
Run Hours	set time and date
PIN code	set PIN code

Table 5-6. Security menu

Main menu items	Purpose
Customer files	store customer files
Green Button	choose button function

5.1.2 Where to find a function

The following table contains an alphabetical list of the functions and points to their location in the system menu structure.

Table 5-7. System menu functions

	Function	Subfunction	Menu path
A			
	Adapter		
		12nc	DIAGNOSTICS
		Type	DIAGNOSTICS
		Version	DIAGNOSTICS
		Software Status	DIAGNOSTICS
	Aspect Ratio		
		Select	INSTALL \ ASP RATIO
		Local/remote switching	INSTALL \ ASP RATIO
	Audio		
		Gain	INSTALL \ AUDIO
		HP filter	INSTALL \ AUDIO
		Bar switch	VF
	Auto Iris switch		LENS
	Auto Iris setpoint		LENS
	Auto White speed		INSTALL \ AUTO WHITE
	Auto White gain		INSTALL \ AUTO WHITE
B			
	Base Station		DIAGNOSTICS \ COMMUNICATION
	Black		
		Dynamic Black	VIDEO \ BLACK
		level	VIDEO \ BLACK \ MASTER
		level Blue	VIDEO \ BLACK \ MORE
		level Green	VIDEO \ BLACK \ MORE

Table 5-7. System menu functions

	Function	Subfunction	Menu path
		level Red	VIDEO \ BLACK \ MORE
		Stretch level	VIDEO \ BLACK
C			
	Camera		
		12nc	DIAGNOSTICS
		Boot version	DIAGNOSTICS
		FPGA	DIAGNOSTICS
		Matching	FILES \ STANDARD FILES
		Mic. Gain	INSTALL
		Mic. Phantom	INSTALL
		Software Status	DIAGNOSTICS
		Version	DIAGNOSTICS
	Communication		DIAGNOSTICS
	Contour		
		Auto Skin select	VIDEO \ SKIN
		Coarse/Fine level	VIDEO \ CONTOUR \ MORE
		level	VIDEO \ CONTOUR
		level Depend	VIDEO \ CONTOUR \ MORE
		Knee Contour switch	VIDEO
		Noise Slicer	VIDEO \ CONTOUR \ MORE
		Skin Contour	VIDEO \ SKIN
		Skin Contour level	VIDEO \ SKIN
		Skin Contour param.	VIDEO \ SKIN \ MORE
		Skin Contour select	VIDEO \ SKIN
		Skin Contour view	VIDEO \ SKIN
		Soft Contour level	VIDEO \ SOFT \ CONTOUR
		Soft Contour switch	VIDEO \ SOFT \ CONTOUR
		Source select	VIDEO \ CONTOUR
		Vertical level	VIDEO \ CONTOUR \ MORE
		VF Contour	VF \ VF CONTOUR
	Creative settings		FILES \ STANDARD FILES
	Customer Standard file		

Table 5-7. System menu functions

	Function	Subfunction	Menu path
		store Scene file	SECURITY \ CUSTOMER FILES
		store Oper. file	SECURITY \ CUSTOMER FILES
		store VTR file	SECURITY \ CUSTOMER FILES
		Green Button select	SECURITY \ GREEN BUTTON
D			
	Disable Camera		INSTALL
	Dynamic black		VIDEO \ BLACK
E			
	Exposure time lighting		INSTALL \ EXPOSURE
	Exposure time var		INSTALL \ EXPOSURE
	Extended Iris param.		LENS \ EXTENDED IRIS
F			
	File Attributes		FILES
	Filter Settings Colour		VIDEO \ COLOUR FILTER
	Flare switch		VIDEO \ FLARE
	Flare parameters		VIDEO \ FLARE
	Front Power		DIAGNOSTICS
G			
	Gain		
		Blue	VIDEO \ GAIN
		Green	VIDEO \ GAIN
		Red	VIDEO \ GAIN
		level presets	INSTALL \ GAIN \ PRESET
	Gamma		
		Curve select	VIDEO \ GAMMA \ MORE
		level Blue	VIDEO \ GAMMA
		level Green	VIDEO \ GAMMA
		level Master	VIDEO \ GAMMA
		level Red	VIDEO \ GAMMA
		switch	VIDEO \ GAMMA \ MORE
	Green Button settings		SECURITY
I			

Table 5-7. System menu functions

	Function	Subfunction	Menu path
	Installed User Level		SECURITY
	Intercom side tone		INSTALL
	Iris		
		Peak/Average level	LENS
		Set Point level	LENS
	IR receiver switch		INSTALL
K			
	Knee		
		Contour switch	VIDEO \ KNEE CONTOUR
		Master point	VIDEO \ KNEE
		Master slope	VIDEO \ KNEE
		select source	VIDEO \ KNEE
		parameters	VIDEO \ KNEE \ MORE
		switch	VIDEO \ KNEE
L			
	Lens		
		Extended iris	LENS
		Time speed	LENS
		Auto Iris switch	LENS
		Auto Iris Setpoint	LENS
		Extended Iris	LENS
		Manufacturer	LENS
		mom. Iris Setpoint	LENS
		Iris Peak/Average	LENS
		Type	LENS
	Lighting conditions	Files \ Standard Files	
M			
	Marker		VF
	Marker Type		VF
	Matrix select		VIDEO \ MATRIX
	Matrix parameters		VIDEO \ MATRIX
	Master black		VIDEO \ BLACK

Table 5-7. System menu functions

	Function	Subfunction	Menu path
	MCP		DIAGNOSTICS \ COMMUNICATION
O			
	OCP		DIAGNOSTICS \ COMMUNICATION
	On Air lamp switch		INSTALL \ ON AIR LAMP
	Operator file recall		FILES \ RECALL OPER. FILE
	Operator file store		FILES \ OPER. FILE
P			
	PIN code		SECURITY
Q			
	Quick Smart Touch		INSTALL \ QUICK SMART TOUCH
R			
	Recall Scene file		FILES
	Recall Oper. file		FILES
	Run Hours settings		SECURITY
	Rotary speed		VF
S			
	Scene file recall switch		FILES \ RECALL SCENEFILE
	Scene file store switch		FILES \ STORE SCENEFILE
	Skin Contour		VIDEO \ SKIN
	Sensor Type		DIAGNOSTICS
	Sensor Voltage		DIAGNOSTICS
	Shading parameters		VIDEO \ SHADING
	Shading switch		VIDEO \ SHADING
	Shutter Run		DIAGNOSTICS
	Standard files		FILES
	Standard Settings		FILES \ STANDARD FILES
	Store Scene file		FILES
	Store oper. file		FILES
	Soft Contour		VIDEO \ SOFT CONTOUR
	Software status		DIAGNOSTICS
T			
	Tally Light switch		INSTALL

Table 5-7. System menu functions

	Function	Subfunction	Menu path
U			
	User level select		SECURITY \ INSTALLED LEVEL
V			
	VF		
		4:3 Area type	VF
		Audio Bar switch	VF
		Contour level	VF \ VF CONTOUR
		Contour switch	VF \ VF CONTOUR
		Centre Cross switch	VF
		Focus ind. switch	VF
		Iris Indicator switch	VF
		Info time	VF
		Menu time	VF
		Rotary speed	VF
		Safe Area switch	VF
		Text Display time	VF
		Zebra switch	VF
		Zebra parameters	VF
		Zoom ind. switch	VF
	Video mode		INSTALL
W			
	White Limit switch		VIDEO \ WHITE LIMIT
	White Limit Master		VIDEO \ WHITE LIMIT
Z			
	Zebra		
		Contrast	VF \ ZEBRA
		level	VF \ ZEBRA
		mode	VF \ ZEBRA
		switch	VF \ ZEBRA
	Zoom		INSTALL

