

User's Guide

3922 496 30781 March 2007 v1.0

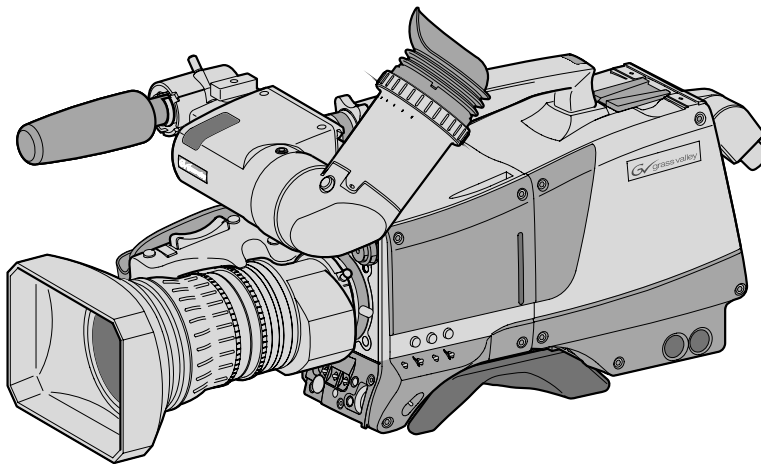

LDK 4000 MKII

HDTV camera system

Declaration of Conformity

We, Grass Valley Nederland B.V., Kapittelweg 10, 4827 HG Breda, The Netherlands, declare under our sole responsibility that this product is in compliance with the following standards:

- EN60065 : Safety
- EN55103-1: EMC (Emission)
- EN55103-2: EMC (Immunity)

following the provisions of:

- a. the Safety Directives 73/23/EEC and 93/68/EEC
- b. the EMC Directives 89/336/EEC and 93/68/EEC

FCC Class A Statement

This product generates, uses, and can radiate radio frequency energy and if not installed and used in accordance with the instructions, may cause interference to radio communications.

It has been tested and found to comply with the limits for a class A digital device pursuant to part 15 of the FCC rules, which are designed to provide reasonable protection against such interference when operated in a commercial environment.

Operation of this product in a residential area is likely to cause interference in which case the user at his own expense will be required to take whatever measures may be required to correct the interference.

Copyright

Copyright Grass Valley Nederland B.V. 2006. Copying of this document and giving it to others, and the use or communication of the contents thereof, are forbidden without express authority. Offenders are liable to the payment of damages. All rights are reserved in the event of the grant of a patent or the registration of a utility model or design. Liable to technical alterations in the course of further development.

Trademarks

Grass Valley and Infinity are trademarks of Grass Valley, Inc. All other tradenames referenced are service marks, trademarks, or registered trademarks of their respective companies.

Website

Visit the Grass Valley public website to download the latest user's guide updates and additional information about your broadcast product:

<http://www.thomsongrassvalley.com>

Chapter 1 – Introduction

1.1	Technology	1-1
1.1.1	HD sensors	1-1
1.1.2	Digital processing	1-1
1.1.3	Film-like characteristics	1-2
1.1.4	Focus assist	1-2
1.1.5	Different versions	1-2
1.1.6	Advanced TriaxHD features	1-2
1.1.7	SuperXPander	1-3
1.2	Features	1-3
1.3	Accessories	1-5

Chapter 2 – Installation

2.1	Packing/unpacking	2-1
2.2	Transport case	2-2
2.3	Mounting a lens	2-3
2.4	2-inch viewfinder	2-4
2.4.1	Mounting viewfinder and microphone holder	2-4
2.4.2	Positioning the viewfinder	2-5
2.5	Viewfinder accessories	2-6
2.5.1	Wide angle eyepiece	2-6
2.5.2	Left eye adapter	2-6
2.6	Mounting a microphone	2-7
2.7	Tripod adapter plate	2-8
2.8	Adjusting the shoulder pad	2-9
2.9	Attaching an adapter	2-10

Chapter 3 – Configurations

3.1	TriaxHD mode	3-1
3.2	Multiple TriaxHD cameras with C2IP network	3-2
3.3	Camera with TriaxHD adapter and SuperXPander	3-3
3.4	Local mode	3-4
3.5	Triax cable lengths	3-5

Chapter 4 – Location of controls

4.1	Camera head controls and connectors	4-1
4.2	TriaxHD adapter controls and connectors	4-4
4.3	Viewfinder controls and indicators	4-6

Chapter 5 – Operating instructions

5.1	Using the camera	5-1
5.1.1	Switching on the power	5-1
5.1.2	Controlling the camera	5-1
5.2	System Menu	5-2
5.2.1	Entering the System menu	5-2
5.2.2	Finding your way	5-3
5.2.3	Leaving the System Menu	5-4
5.2.4	Making changes	5-4
5.2.5	Undoing changes	5-4
5.3	Assigning functions to buttons	5-5

5.4	Video acquisition modes	5-6
5.5	Viewfinder preferences	5-7
	5.5.1 Viewfinder picture quality	5-7
	5.5.2 Video level indication	5-7
	5.5.3 Tally indicators	5-7
	5.5.4 Viewfinder markers	5-8
	5.5.5 Focussing	5-8
5.6	Lens preferences	5-9
	5.6.1 Lens type	5-9
	5.6.2 Auto iris	5-9
	5.6.3 Extended Iris	5-9
	5.6.4 Lens indicators	5-9
5.7	Video preferences	5-10
	5.7.1 Standard settings	5-10
	5.7.2 Test signal	5-11
	5.7.3 Gain selection	5-12
	5.7.4 Optical filter selection	5-12
	5.7.5 Colour temperature selection	5-13
	5.7.6 Exposure time	5-17
	5.7.7 Shooting screens	5-18
	5.7.8 Black stretch	5-19
	5.7.9 Auto skin contour	5-19
5.8	Controls on the TriaxHD adapter	5-21
	5.8.1 Powering the camera	5-21
	5.8.2 Selecting monitoring signals	5-22
	5.8.3 Using audio	5-23
	5.8.4 Intercom	5-24
	5.8.5 Communication	5-25
5.9	Managing files	5-26
	5.9.1 Scene files	5-26
	5.9.2 Operator files	5-26
	5.9.3 Standard files	5-27
	5.9.4 Customer standard files	5-27
5.10	User levels	5-27
	5.10.1 Selecting the user level	5-27
5.11	Access and Security	5-28
	5.11.1 Camera cards	5-28
	5.11.2 Access control	5-29
	5.11.3 Camera card slot	5-29
5.12	Smart-Touch™ option	5-30

Chapter 6 – Menu structure and contents

6.1	Menu structure	6-1
	6.1.1 Top menu structure	6-1
	6.1.2 Viewfinder menu structure	6-2
	6.1.3 Lens menu structure	6-3
	6.1.4 Video menu structure	6-4
	6.1.5 Install menu structure (HDTriax)	6-5
	6.1.6 File menu structure	6-6
	6.1.7 Security menu structure	6-7

6.2	Menu contents	6-8
6.2.1	Viewfinder menu contents	6-8
6.2.2	Lens menu contents	6-10
6.2.3	Video menu contents	6-11
6.2.4	Install menu contents	6-13
6.2.5	Files menu contents	6-15
6.2.6	Security menu contents	6-16
6.2.7	Diagnostics menu contents	6-17
6.3	Where to find a function	6-18

Chapter 7 – Connectors

7.1	Camera connectors	7-1
7.1.1	Viewfinder connector	7-2
7.1.2	HDMI connector	7-2
7.1.3	Lens connector	7-3
7.1.4	Audio microphone connector	7-3
7.1.5	RS232 serial connector	7-3
7.2	Connectors on the TriaxHD adapter	7-4
7.2.1	Triax connector	7-5
7.2.2	Viewfinder / External video output connector	7-5
7.2.3	HD - SDI (B) connector	7-5
7.2.4	HD - SDI (A) connector	7-5
7.2.5	Audio microphone 1 connector	7-6
7.2.6	Audio microphone 2 connector	7-6
7.2.7	Intercom headset connector	7-6
7.2.8	DC power input socket	7-7
7.2.9	DC power and tally output socket	7-7
7.2.10	Script light power supply socket	7-7
7.2.11	Teleprompter output / Reference input connector	7-8
7.2.12	Tracker communications connector	7-8
7.2.13	Auxiliary connector	7-9

Chapter 8 – Specifications

8.1	Specifications for LDK 4000 MKII	8-1
8.2	Specifications for LDK 5860 TriaxHD adapter	8-2
8.2.1	Dimensions	8-3

End-of-life product recycling

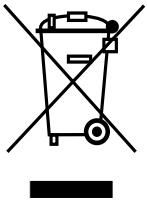

Grass Valley's innovation and excellence in product design also extends to the programs we've established to manage the recycling of our products. Grass Valley has developed a comprehensive end-of-life product take back program for recycle or disposal of end-of-life products. Our program meets the requirements of the European Union's WEEE Directive and in the United States from the Environmental Protection Agency, individual state or local agencies.

Grass Valley's end-of-life product take back program assures proper disposal by use of Best Available Technology. This program accepts any Grass Valley branded equipment. Upon request, a Certificate of Recycling or a Certificate of Destruction, depending on the ultimate disposition of the product, can be sent to the requester.

Grass Valley will be responsible for all costs associated with recycling and disposal, including freight, however you are responsible for the removal of the equipment from your facility and packing the equipment ready for pickup.

For further information on the Grass Valley product take back system please contact Grass Valley at + 800 80 80 20 20 or +33 1 48 25 20 20 from most other countries. In the US and Canada please call 800-547-8949 or 530-478-4148. Ask to be connected to the EH&S Department. In addition, information concerning the program can be found at:

www.thomsongrassvalley.com/environment

Important information

Read these instructions carefully and retain them for future reference.

During installation and operation of this equipment, local building safety and fire protection standards must be observed.

Before connecting the equipment to the power supply of the installation, verify the proper functioning of the protective earth lead.

Whenever it is likely that safe operation is impaired, the apparatus must be made inoperative and secured against any unintended operation. The appropriate servicing authority must then be informed. For example, safety is likely to be impaired if the apparatus fails to perform the intended function or shows visible damage.

Any changes or modifications not expressly approved in this manual could void your authority to operate this equipment.

Cautions and Warnings

Read and comply with the warning and caution notices that appear in the manual.

- Warnings indicate danger that requires correct procedures or practices to prevent death or injury to personnel.
 - Cautions indicate procedures or practices that should be followed to prevent damage or destruction to equipment or property.
-

Warnings

To prevent fire or shock hazard, do not expose the unit to rain or moisture. If the unit is in a wet or damp environment, a rain cover must be used to protect it for personal safety reasons (EN60065). The rain cover supplied with the unit protects it according to safety specification EN60529 up to level IPX2 (spraying water).



To avoid electrical shock, do not remove covers or panels. Refer servicing to qualified personnel only.



In case of an emergency ensure that the power is disconnected.



Use only fuses of the type and rating specified.



Connect the product only to a power source with the specified voltage rating.



The Base Station must always be connected to protective earth. Do not interrupt the protection conductor inside or outside the unit. Do not disconnect the protective earth terminal. Intentional interruption is prohibited and is likely to make the unit dangerous.



To prevent risk of overheating, ventilate the units correctly.



For safety reasons the Base Station must be mounted in a 19-inch rack which has safety covers according to IEC65. When two Base Stations are mounted above each other, the minimum distance between them must be 50mm or the rack must be force-air cooled.

Triax cable systems

Only connect a Triax cable from the same LDK camera family to the unit.



Do not allow system earth currents to exceed 1.5A in the outer shield of the Triax cable or 0.2A in other cable shields.



To avoid excessive earth currents in a Triax system, galvanically separate the power earth connection of equipment connected to the camera from the camera earth.



It is strictly prohibited to short circuit the inner and outer shields of a Triax cable used to connect a camera to a base station.

Galvanic separation

Because of the nature of Triax systems, with long distances between camera and Base Station, the risk of earth currents flowing is greater. These earth currents can result in damage to the equipment.

For example, a monitor connected directly to the CVBS output of the camera is powered locally. The earthing point of the monitor's power supply can be at a different potential with respect to the earthing point of the Base Station. If the power earth of the monitor is also the video earth, then this earth potential is transferred to the camera via the shield of the BNC connector. The difference in earth potential between the camera and the Base Station results in an earth current in the Triax system.

To prevent earth currents from flowing in the Triax system, we recommend galvanic separation of earthed equipment connected to the camera. This separation can be achieved by using an isolation transformer between the local power outlet and the equipment connected to the camera. Alternatively, use equipment that has a double insulation and therefore does not require an earth connection.

Base Station earthing

The rear of the unit has two separate screw terminals for protective earth \oplus (PE) and video earth \ominus (VE). These are normally connected by a metal strap.

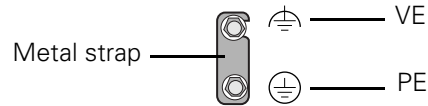

The protective earth terminal is internally connected to the protective earth conductor of the power cable. In normal circumstances the connection between the protective earth and the video earth should **not** be broken. If required, the central earth connection wire of the studio can be connected to terminal PE in accordance with VDE regulation 0800/part2.

Only if the studio (or OB van) is equipped with separate protective and video earth systems may the metal strap be removed. Under these circumstances the video earth terminal must be connected to the central functional earth potential (video earth) of the studio. This earth potential should have functional protective and noiseless earth (FPE) qualities as stated in the VDE regulation 0800/part2. A low impedance interconnection of both earth conductors must be provided at the central studio earthing point.

Precautions

To ensure continual high performance from the camera take the following precautions into consideration:

- Avoid very damp places. If the environment is wet or damp a rain cover must be used to protect the unit.
- Do not subject the unit to severe shocks or vibration.
- Do not expose the camera to extremes of temperature.
- Do not leave the unit in direct sunlight or close to heating appliances for extended periods.
- Do not allow sunlight to shine into the viewfinder.
- Do not allow LASER beams to shine into the lens as this could damage the CCD sensors.
- Avoid extreme highlights as these can cause various kinds of optical reflections.
- Be careful when connecting and disconnecting triax cables.
 - Do not mix triax units from different types of camera systems (HD with SD, RGB triax with digital triax).
 - Make connections swiftly and firmly to avoid false error messages.

Mains lead wiring for UK users

The wires in the mains lead are coloured in accordance with the following code:

GREEN and YELLOW- EARTH

BLUE- NEUTRAL

BROWN- LIVE

As the colours of the wires in the mains lead of this apparatus may not correspond with the coloured markings identifying the terminals in your plug proceed as follows:

- The wire coloured GREEN AND YELLOW must be connected to the terminal on the plug marked with the letter E or by the safety earth symbol \oplus or coloured GREEN or GREEN AND YELLOW.
- The wire coloured BROWN must be connected to the terminal marked with the letter L or coloured RED.
- The wire coloured BLUE must be connected to the terminal marked with the letter N or coloured BLACK.

Ensure that your equipment is connected correctly - if you are in any doubt consult a qualified electrician.



Chapter 1

Introduction

1.1 Technology

The LDK 4000 MKII is a high definition, single-standard digital camera head using three 2/3-inch HD-DPM⁺™ sensors. The camera head can be combined with the TriaxHD adapter for a flexible camera that is equally at home in the studio or out on location.

1.1.1 HD sensors

The camera head uses HD-DPM⁺™ CCD sensors which offer superior performance and ultimate flexibility. Native wide screen pictures in the high-definition formats 1080i or 720p are produced depending on the camera version you require. This unique native capability is realized with innovative 9.2 million pixel CCD sensors.

These sensors have a high dynamic range and high linear sensitivity across all camera lens apertures. They are based on Frame Transfer technology, which ensures that there is neither lag nor smear.

1.1.2 Digital processing

The advanced digital processing of the camera is based on 14-bit A/D converters and more than 22-bit internal processing. All major camera functions are processed in the digital domain, including knee, gamma, contour, matrix and colour correction.

The intelligent continuous automatics facility provides automatic control of black levels and black shading. Each sensor provides black reference signals that are used to monitor temperature changes. This means that continuous automatic correction is applied without operator intervention.

The digital contour processing uses full amplitude video RGB signals via an extended dynamic range contour circuit. Colorimetry is selected by means of a variable 6-point digital matrix or via preset matrices. Digital gamma circuits provide a wide range of standardised gamma curves and enable soft contrast in black scenes to be enhanced, together with hard contrast and saturated colour in bright scenes. The matrix and gamma sequence is software programmable for precise colour matching.

1.1.3 Film-like characteristics

The pivoting knee circuit adapts both the knee point and the compression ratio according to the highlight content of the picture to emulate the softly limiting S-shaped transfer characteristics of film. Digital True Colour Knee circuitry maintains the correct hue for compressed highlights, reproducing colours faithfully, even overexposed skin tones.

Digital contrast circuitry provides a black stretch function for more detail in black areas and a black press function for improving the contrast impression by simulating the S-curve of film.

1.1.4 Focus assist

With HDTV, focusing is even more critical than before. The LDK 4000 MKII has special patented focusing aids. A unique viewfinder zoom function enlarges the viewfinder image instantly with a simple press-button action, thus providing improved means for focusing. A patented crawler circuitry adds motion in the viewfinder to objects in sharp focus.

1.1.5 Different versions

The LDK 4000 MKII camera head is available in two versions - 1080i or 720p. These versions support either 1080i or 720p HD formats in 50 Hz and 59.94 Hz. You decide when ordering which version you require. These standards cannot be changed later.

1.1.6 Advanced TriaxHD features

TriaxHD, which is a further development of the Emmy Award winning triax transmission system, makes the camera compatible with industry standard triax cables. This allows the reuse of existing, reliable and valuable cable inventories.

TriaxHD allows video transmission and remote control of cameras up to a distance of 3300 ft (1000 meters) and beyond, using industry standard 14mm triax cables. It is based on 30MHz full-bandwidth 4:2:2 transmission (Y/Cr/Cb components).

The double side band modulation technique used in combination with Y/Cr/Cb transmission ensures linearity, resolution and an optimal signal-to-noise ratio over the maximum cable length. Bandwidth efficient channel combining and equalization techniques minimize cross-talk and interference. Teleprompter and viewfinder signals maintain high performance with relatively long cable lengths.

The communication facilities provide for two-wire or four-wire high quality intercom signals. Full camera control is provided via a C2IP Ethernet-based control network.

The TriaxHD adapter is equipped with a rotary triax connector which provides freedom of movement during portable use of the camera and protects the connector from being damaged in near-floor conditions.

TriaxHD Base Station

The TriaxHD Base Station, as well as providing high definition outputs, optionally offers simultaneous high-end SDTV outputs. This facilitates a gradual and managed transition from SDTV to HDTV.

1.1.7 SuperXPander

The SuperXPander together with the optional 7-inch HD high resolution viewfinder turns the portable triax camera into a full-featured studio camera for studio and EFP situations.

1.2 Features

- Ultimate flexibility with HD-DPM+™ CCD sensors, offering either native interlaced 1080i or true progressive 720p high definition broadcast formats (depending on version).
- The CCDs have 9.2 million pixels, with 1920 (H) x 4320 (V) effective picture elements.
- The following acquisition format versions are available:
 - 1080i at 59.94 Hz and 50 Hz
 - or
 - 720p at 59.94 Hz and 50 Hz
- Frame Transfer technology ensures no smear.
- 14-bit A-to-D and more than 22-bit digital processing with unique software programmable video path.
- Superior all digital highlight handling with a wide dynamic range.
- Unique circuitry for pivoting knee and True Colour Knee.
- Variable gain control and variable colour temperature.
- Wide range of presets and variable 6-point digital matrix assure accurate colour matching.
- Fluorescent light matrix.
- Digital gamma with unique standard preset values and highest accuracy.
- Digital contour with an extensive range of parameters.
- Advanced contour correction includes two automatic skin settings.
- Intelligent Continuous Automatics black levels, black shading and video levels - no set-up time required.
- Digital contrast with standard black stretch and black press.
- International standard 2/3-inch lens interface.
- Optical servo-controlled four-position neutral density filter wheel.
- Optical servo-controlled effect filter wheel with soft focus, four-point star and six-point star filters.
- Electronic colour filter can be used for creating a special look (warm/cold) of a scene, or for a smooth colour temperature control around the white balance setting.
- Smart card for personal settings and security.
- Owner card for setting user levels, and for copying and storing control settings.
- Protected, easy-to-operate controls and switches with read-out of all settings.
- Viewfinder status read-out of primary camera functions.
- Clean scan feature allows capture of computer and other monitor pictures.

1.3 Accessories

Xpander	LDK 4489
SuperXpander	LDK 4488
7" viewfinder support	LDK 6517
HD/HS Triax Repeater	LDK 4800
2" viewfinder HDTV	LDK 5302/60
5" viewfinder HDTV	LDK 5305/01
7" viewfinder HDTV High Brightness	LDK 4020/20
Wide Angle adapter for 2" VF	LDK 5390/00
Left eye adapter for 2" VF	LDK 5390/10
Sunhood for 5" VF	LDK 6992/02
Raincover for camera with 5"VF	LDK 5021/05
Tripod plate	LDK 5031/10
Headset dynamic XLR-5 double muff	LDK 8111/37
Headset dynamic XLR-5 single muff	LDK 8111/51
Scriptboard with light	LDK 6985/21
Transport/flightcase	LDK 5020
Carrying bag	LDK 5020/01
AC power supply 100 W	LDK 5901/00

Chapter 2

Installation

2.1 Packing/unpacking

Inspect the shipping container for evidence of damage immediately after receipt. If the shipping container or cushioning material is damaged, it should be kept until the contents of the shipment have been checked for completeness and the units have been checked mechanically and electrically.

The shipping container should be placed upright and opened from the top. Remove the cushioning material and lift out the contents. The contents of the shipment should be checked against the packing list. If the contents are incomplete, if there is mechanical damage or defect, or if the units do not perform correctly when unpacked, notify your Grass Valley Nederland B.V. sales or service centre within eight days. If the shipping container shows signs of damage or stress, notify the carrier as well.

If a unit is being returned to Grass Valley Nederland B.V. for servicing, try to use the containers and materials of the original packaging. Attach a tag indicating the type of service required, return address, model number, full serial number and the return number which will be supplied by your Grass Valley Nederland B.V. service centre.

If the original packing can no longer be used, the following general instructions should be used for repacking with commercially available materials:

1. Wrap unit in heavy paper or plastic.
2. Use strong shipping container.
3. Use a layer of shock-absorbing material around all sides of the unit to provide firm cushioning and prevent movement inside container.
4. Seal shipping container securely.
5. Mark shipping container FRAGILE to ensure careful handling.

2.2 Transport case

It is important to protect your camera against damage when transporting it. To do this, a transport case (LDK 5020/00) is optionally available for the camera, lens, viewfinder and some accessories.

Figure 2-1. Transport case

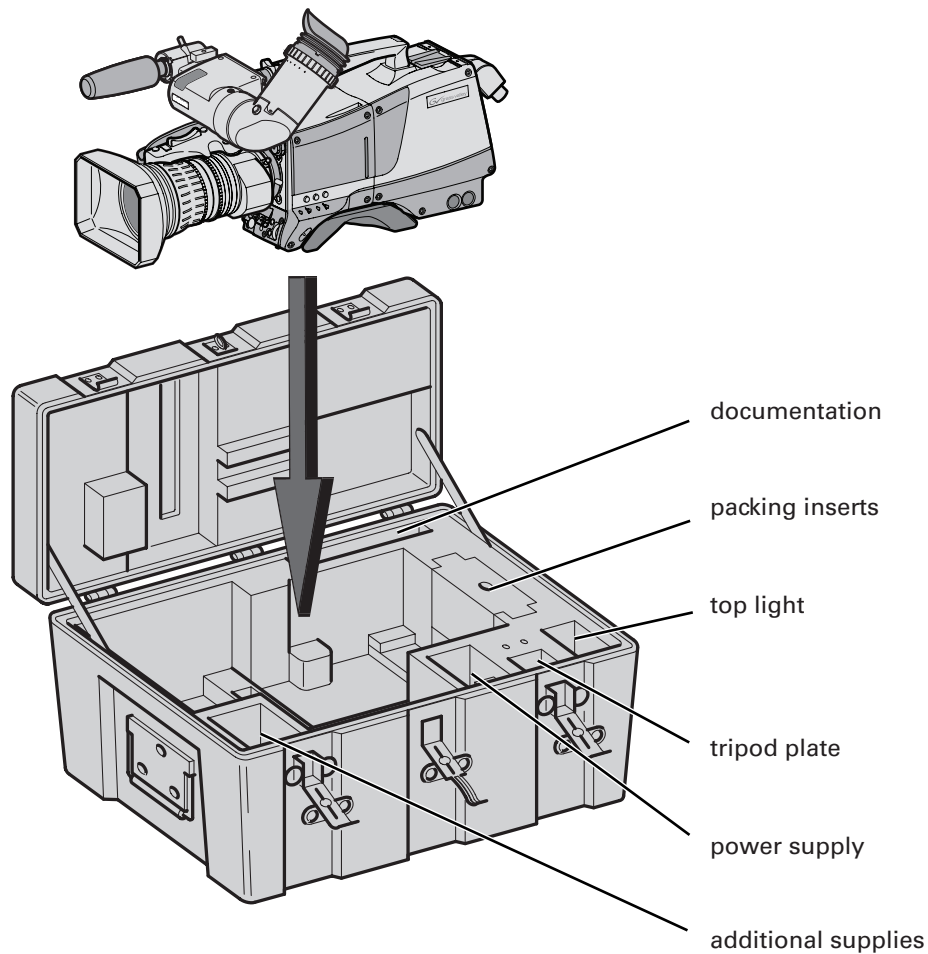

The camera is packed in the transport case as shown in the figure above. This ensures that the camera is not damaged during transport. Turn the 2-inch viewfinder downwards so that it does not protrude above the top of the camera. Several foam packing inserts are provided to enable different configurations of the camera to be packed securely. These inserts are used to support the rear of the camera. Make sure you use the correct foam insert for your particular configuration.

2.3 Mounting a lens

To attach a lens to the camera head proceed as follows:

1. Ensure that the lens locking ring (1) is in the unlocked position - turned counterclockwise.
2. Remove the dust protection cap (2).
3. Slot the lens into the lens mount (3).
4. Turn the lens locking ring (1) clockwise to lock the lens in place.
5. Connect the lens cable to the lens connector (4) at the right side of the camera.
6. Place the lens cable into the bottom clip at the front of the camera and clip (5) located at the side.

Figure 2-2. Lens mounting

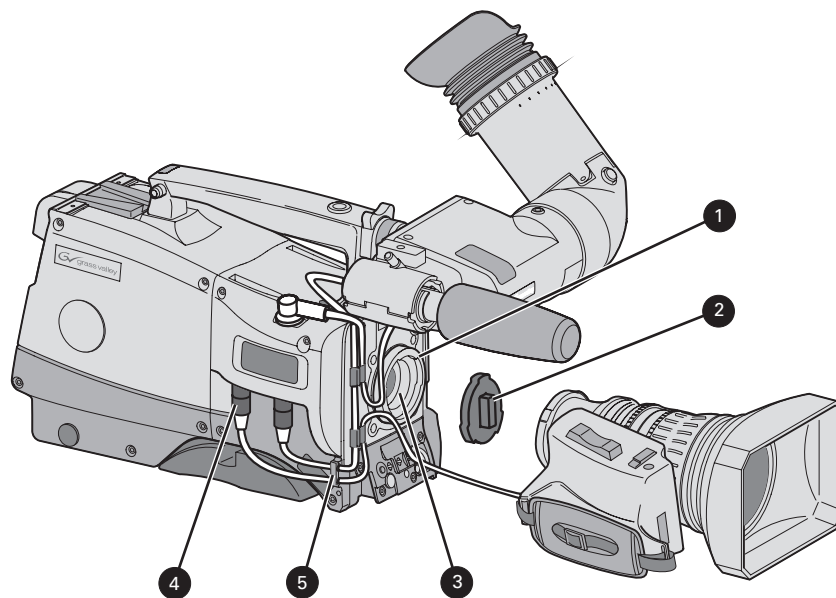

Caution

Do not attach a lens weighing more than 5 kg to the camera without a support.

When a new lens is fitted to the camera it may be necessary to carry out some adjustments to optimize its use, for example, back focus or shading. For more information about these adjustments refer to the lens manufacturer's documentation.



Note

Always mount the dust protection cap when the lens is not connected to the camera.

2.4 2-inch viewfinder

2.4.1 Mounting viewfinder and microphone holder

To mount the viewfinder LDK 5302/60 proceed as follows:

1. Loosen locking ring (1) of viewfinder support bracket (2) at the front of the camera handle. (As seen from the rear of the camera, turning the locking ring counterclockwise moves it towards the handle.)
2. Slide the viewfinder onto the viewfinder support bracket.
3. Tighten the locking ring (1) by turning it clockwise (as seen from rear) so that the viewfinder is mounted securely to the support.
4. Connect the viewfinder cable to the viewfinder connector socket (6) at the top right of the camera.
5. Slide the microphone holder (4) onto the viewfinder and secure with the knurled screw (5).



Caution

Always fit the microphone holder as it functions as a safety stop for the viewfinder.

6. To improve the comfort of the skin contact when using the viewfinder, fit the eye piece cover (3) to the rubber eyepiece. Spare eye piece covers (3922 405 00461) are available at your Grass Valley representative.

Figure 2-3. Viewfinder mounting

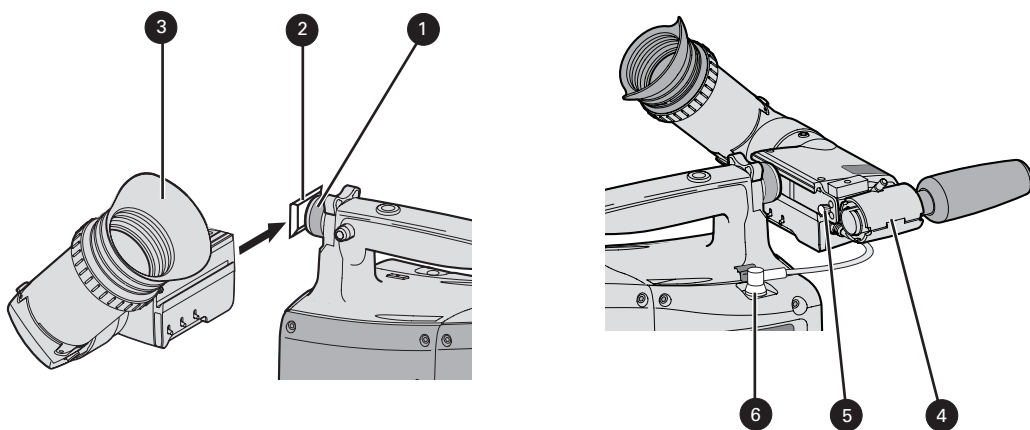

2.4.2 Positioning the viewfinder

The horizontal position of the viewfinder can be adjusted as follows to suit your requirements:

1. Loosen the locking ring (1). (As seen from the rear of the camera, turning the locking ring counterclockwise moves it towards the handle.)
2. Slide the viewfinder horizontally along the rail to the desired position.
3. Tighten the locking ring (1) by turning clockwise.

The dioptre hood and eyepiece of the viewfinder can be rotated vertically.

The viewfinder can be positioned backwards and forwards along the camera axis. Loosen the support bracket round bar retaining lever (2) and slide the round bar (3) forwards or backwards. When the desired position is reached tighten the support bracket round bar retaining lever (2) again.

To use the viewfinder at a distance press the button (4) below or above the eyepiece tube and swing it free of the associated clip (5). The display can now be seen from further away.

Figure 2-4. Viewfinder positioning

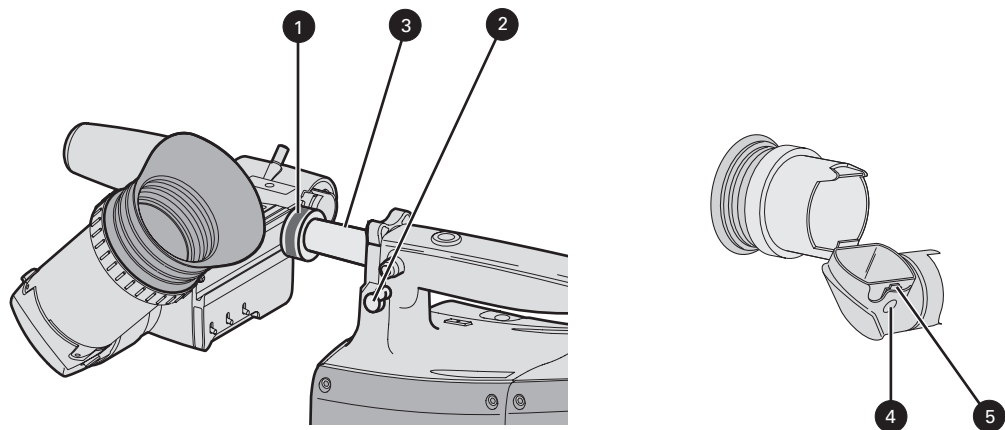

2.5 Viewfinder accessories

2.5.1 Wide angle eyepiece

If you regularly use the viewfinder at a distance, for example, when you use the camera in the hand-held position, it is recommended that you fit the optionally available wide angle eyepiece (LDK 5390/00). To fit the wide angle eyepiece proceed as follows:

1. Hold the eyepiece (1) securely.
2. Press the button (2) below the eyepiece tube and swing it free of the button clip (3).
3. Press the button (4) above the eyepiece tube and remove the eyepiece.
4. Fit the wide angle eyepiece (1) to the two clips (3) ensuring that they both click into place.

Figure 2-5. Viewfinder wide angle eyepiece

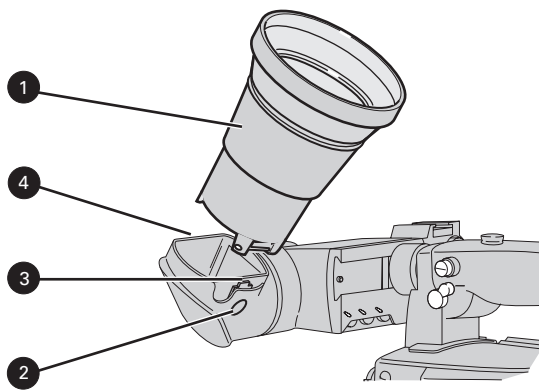

2.5.2 Left eye adapter

A left eye adapter is optionally available (LDK 5390/10) to allow the viewfinder to be used with the left eye. Before mounting the viewfinder onto the camera, attach the left eye adapter (1) to the viewfinder and secure it using the screw (2). Do not forget to mount the microphone support bracket (3) at the end of the left eye adapter.

Figure 2-6. Viewfinder left eye adapter

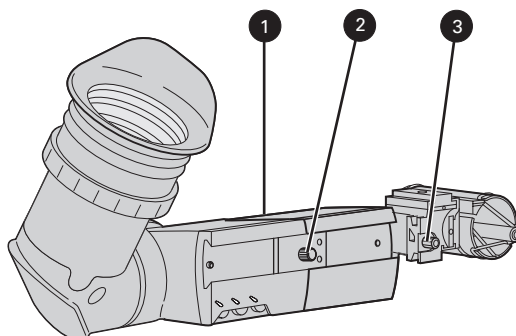

2.6 Mounting a microphone

To attach the optional microphone (AJ-MC700) to the camera proceed as follows:

1. Open the microphone holder by unscrewing the knurled screw (2) of the microphone support bracket (1) on the viewfinder and open.
2. Slide the microphone into the split tube until the microphone shoulder reaches the mark (5) in the tube.
3. Place the tube with the microphone into the holder with the split facing upwards. Mount the microphone as straight as possible.
4. Ensure that the rubber supports at the back and front of the holder fit into the rims (6) around the tube.
5. Close the holder and tighten the knurled screw at the top. Don't allow the wind hood to touch the holder (7) as this reduces the damping effect.
6. Connect the microphone cable to the **MIC** audio connector (3) on the right side of the camera. To avoid mechanical pick-up, do not let the microphone cable touch the holder.
7. Place the microphone cable into the top clip at the front of the camera and into clip (4) at the side of the camera. (Pull and twist clip to open it.)

Other microphones with a diameter of 21mm can also be used, however, ensure that the sensitivity of the input that match that type of microphone are correctly selected in the camera **INSTALL** menu. When a longer microphone is used, it is not necessary to place it in the split tube. Phantom power is always present on the front microphone socket.

Figure 2-7. Microphone mounting

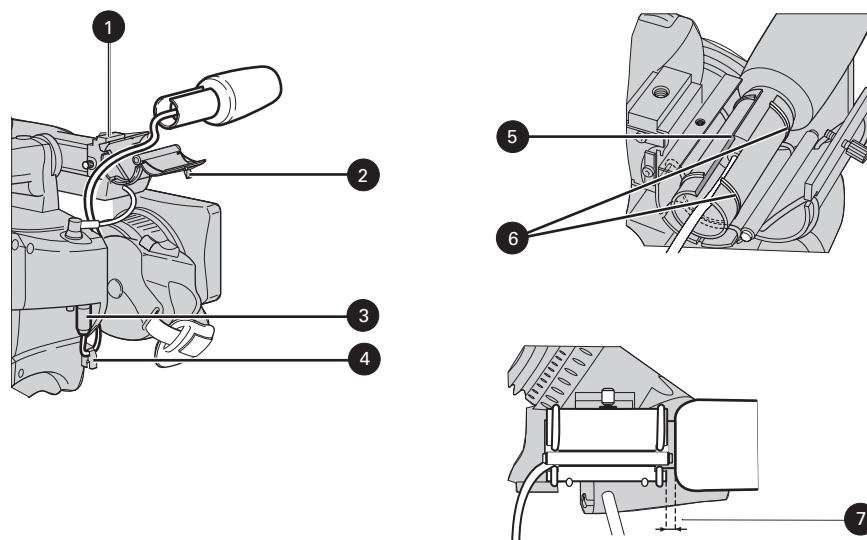

2.7 Tripod adapter plate

To mount the camera on a tripod, the tripod plate LDK 5031/10 must first be attached to the tripod. Follow the tripod manufacturer's instructions to mount the wedge plate supplied with the tripod and the tripod adapter plate firmly onto the tripod. Attach the camera to the tripod adapter plate as follows:

1. Slide the camera horizontally along the tripod adapter plate from back to front ensuring that the front of the camera engages the V-slot (1) at the front of the tripod adapter plate, and that the slot on the bottom of the camera engages the stud (2) at the rear of the tripod adapter plate.
2. Firmly push the camera forward until it clicks into place.
3. When the camera is mounted firmly, the locking lever (5) swings around fully to the rear of the plate. If the lever does not travel the full distance, you should manually lock it into place.



Caution

Failure to attach the camera to the tripod adapter plate in the correct manner could result in an unsecured camera. Ensure that the rear stud (2) is engaged and that the camera clicks into place.

Figure 2-8. Tripod adapter plate

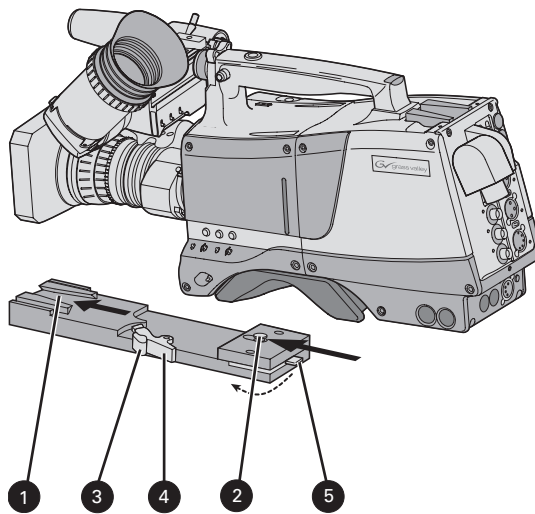

Remove the camera from the tripod as follows:

1. Open the locking lever (5) to free the rear stud (2).
2. Press and hold the red locking lever (3) against the release handle (4).
3. Ensure that you have a firm hold of the camera.
4. Pull the release handle (4) forward.
5. Move the camera backwards and up.

2.8 Adjusting the shoulder pad

To change the position the shoulder pad press and hold lever (1). The shoulder pad can now be moved backwards and forwards along the axis of the camera. Adjust the shoulder pad when all units have been mounted to get the best balanced shoulder position.

Figure 2-9. Shoulder pad

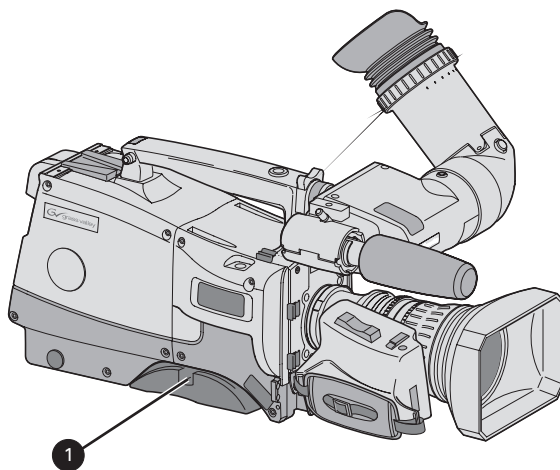

2.9 Attaching an adapter

The camera head is a multi-role camera head that can be used with various adapters.



Caution

Be extremely careful with the connectors between the camera head and the adapter. Do not allow the guide pins to damage the pins of the connector. Follow these steps in the order given. Tightening or loosening the screws in the wrong order could result in mechanical damage to the camera.

To attach an adapter to the camera proceed as follow:

1. Fit the guide pin at the top rear of the camera head and the guide pins on either side of the camera connector into the corresponding slots (1 and 2) of the adapter.
2. First, tighten the two horizontal screws (3) on the top of camera.
3. Next, tighten the two horizontal screws (4) at the front of the camera.
4. Lastly, tighten the vertical screw (5) in the handle of the camera.

To detach an adapter from the camera head follow the steps for attaching it in the reverse order.

Figure 2-10. Attaching an adapter

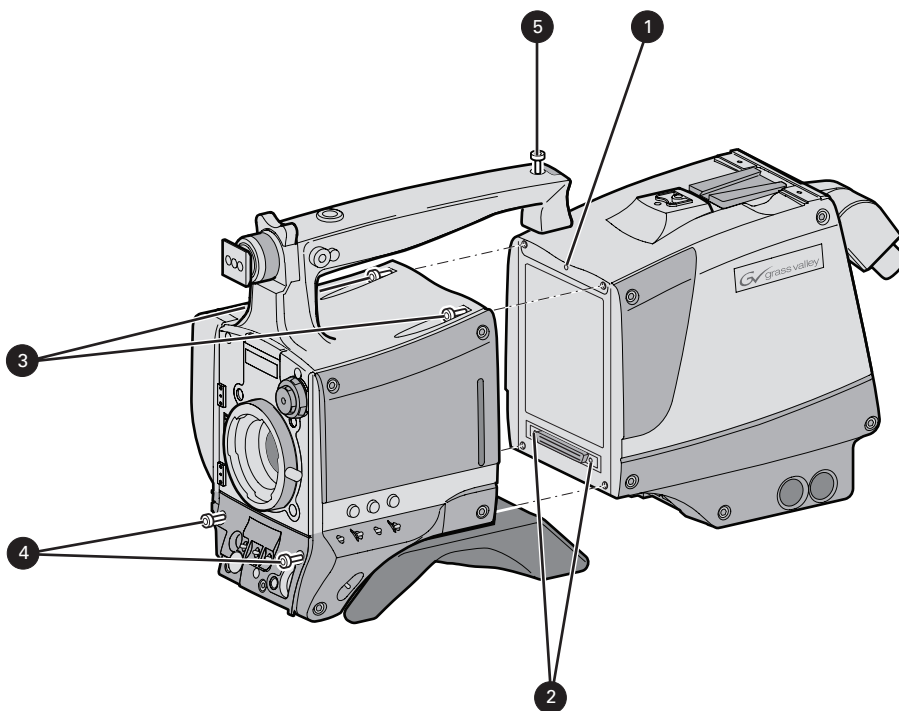

Chapter 3

Configurations

3.1 TriaxHD mode

A camera head with the LDK 5860 TriaxHD adapter is connected to an LDK 4502 HD Base Station using a Triax cable. The maximum length of cable that can be used without significant degradation of the video signal is 1,200m (4,000 ft.) for a 14mm Triax cable.

The power supply is applied to the Base Station and via the Triax cable to the camera. An OCP 400 operational control panel can be connected directly to the Base Station using a cross-over Ethernet cable.

Figure 3-1. Camera in TriaxHD mode

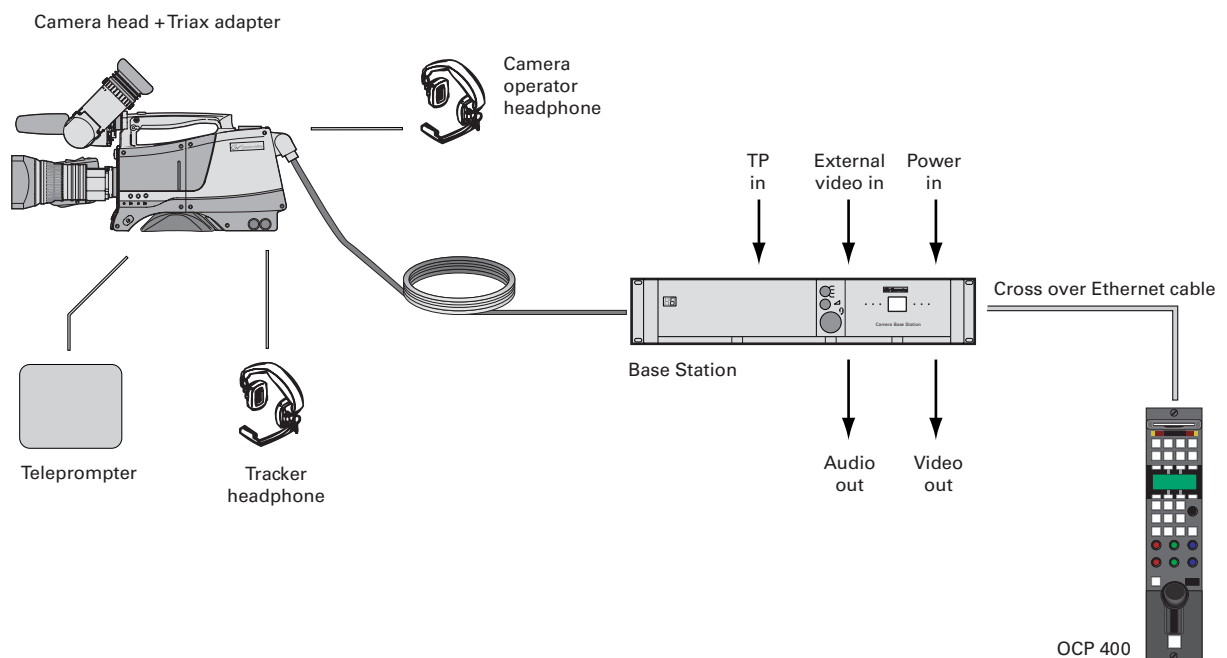

3.2 Multiple TriaxHD cameras with C2IP network

The Base Stations are each connected to a network hub or router via an Ethernet cable (straight through, not cross-over). The OCP 400 operational control panels and, if required the MCP 400 Master Control Panel, are also connected to the Ethernet network via a hub or router.

Figure 3-2. Multiple HD cameras with C2IP network control

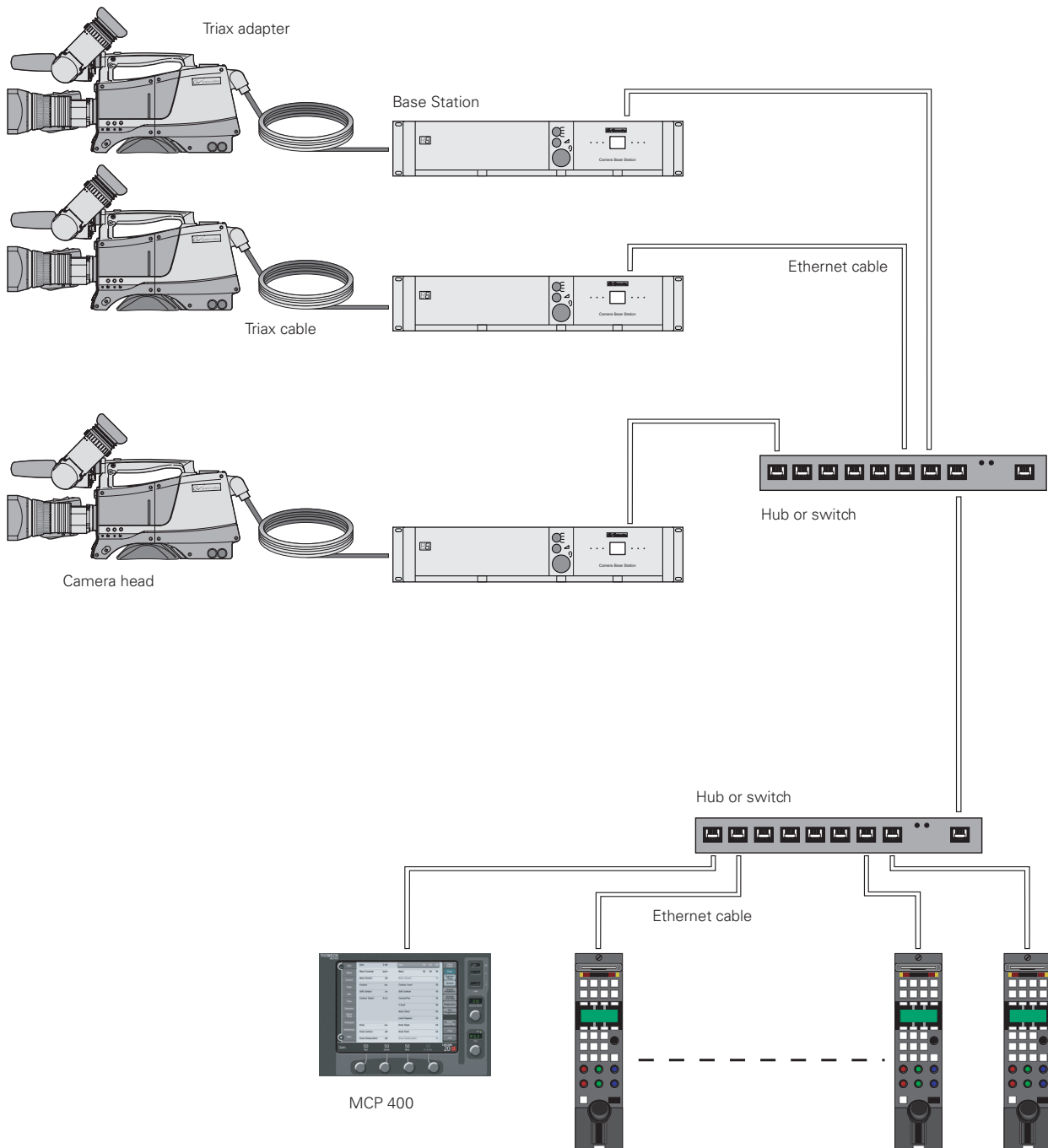

3.3 Camera with TriaxHD adapter and SuperXpander

A camera head with the LDK 5860 TriaxHD adapter can be mounted in the LDK 4488 SuperXpander. This enables large box lenses to be used with the camera. A 7-inch HDTV viewfinder LDK 4020/20 can be mounted on the SuperXpander.

The camera with the TriaxHD adapter connects to the SuperXpander via a flying lead. The power supply for the camera is supplied via this lead. The SuperXpander is connected to an LDK 4502 HD Base Station using a Triax cable. This configuration can be powered either:

- from the Base Station via the triax cable, or
- locally with the mains power supply connected directly to the SuperXpander.

The maximum length of triax cable that can be used without significant degradation of the video signal is 1,200m (4,000 ft.) for a 14mm Triax cable when the configuration is powered locally.

To control the configuration an OCP 400 operational control panel can be connected directly to the Base Station using a cross-over Ethernet cable. The Base Station is powered by a mains power supply.

Figure 3-3. Camera with SuperXpander and TriaxHD adapter

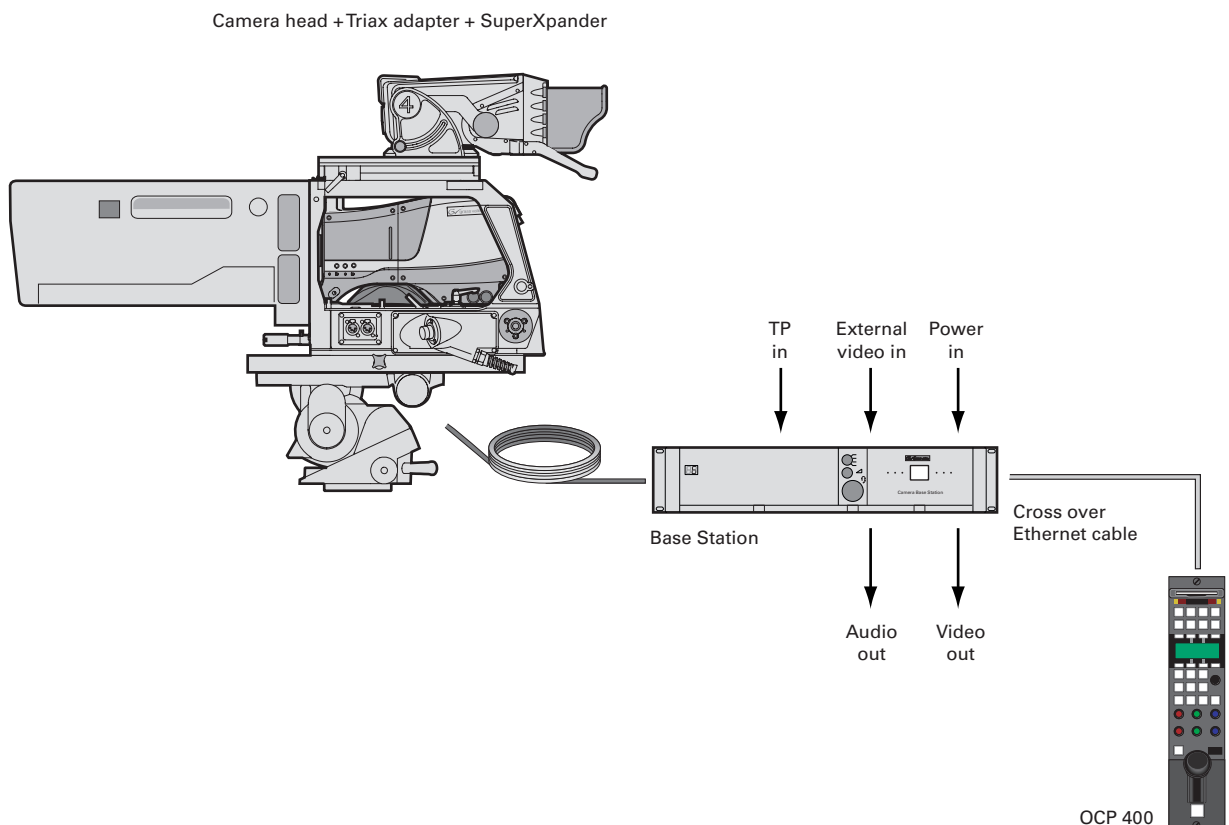

3.4 Local mode

A camera head with the LDK 5860 TriaxHD adapter can be used in the local mode. The DC power supply is applied to the adapter. An OCP 400 operational control panel can be connected directly to the camera using the RS232 connection. A reference signal can be applied to genlock the camera.

The HD SDI (B) connector carries the HD SDI viewfinder signal. The HD SDI (A) connector carries the HD SDI camera signal.

Figure 3-4. Camera in local mode

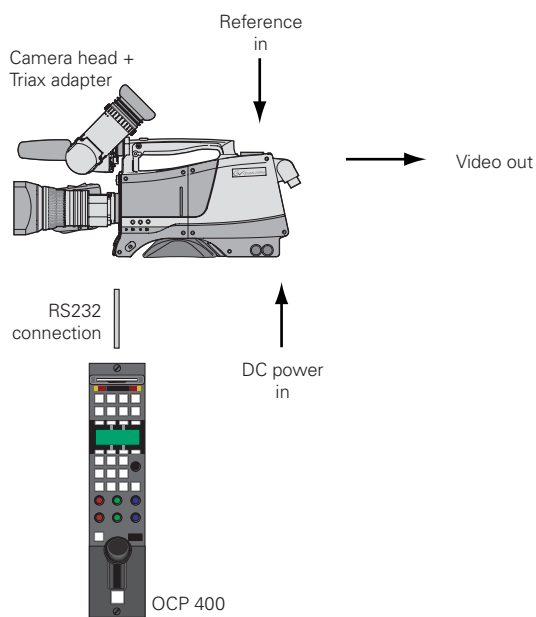

3.5 Triax cable lengths

The approximate maximum cable lengths between a Base Station and a camera are given in the table below. The signal degrades gradually when these lengths are exceeded. Reduce these lengths by 20% when a teleprompter signal is sent to the camera.

The maximum length is given for cables of the highest quality. The quality of some cables and the interconnections can adversely affect this maximum length.

Table 3-1. Triax cable length guide

Cable diameter	Maximum length
8mm / 0.32 inch	500 m / 1,600 ft.
11mm / 0.43 inch	700 m / 2,300 ft.
14mm / 0.55 inch	1,200 m / 4,000 ft.



Note

The maximum cable length for 8mm Triax is adversely influenced by the power consumption of the camera.

Chapter 4

Location of controls

4.1 Camera head controls and connectors

Figure 4-1. Camera connector location

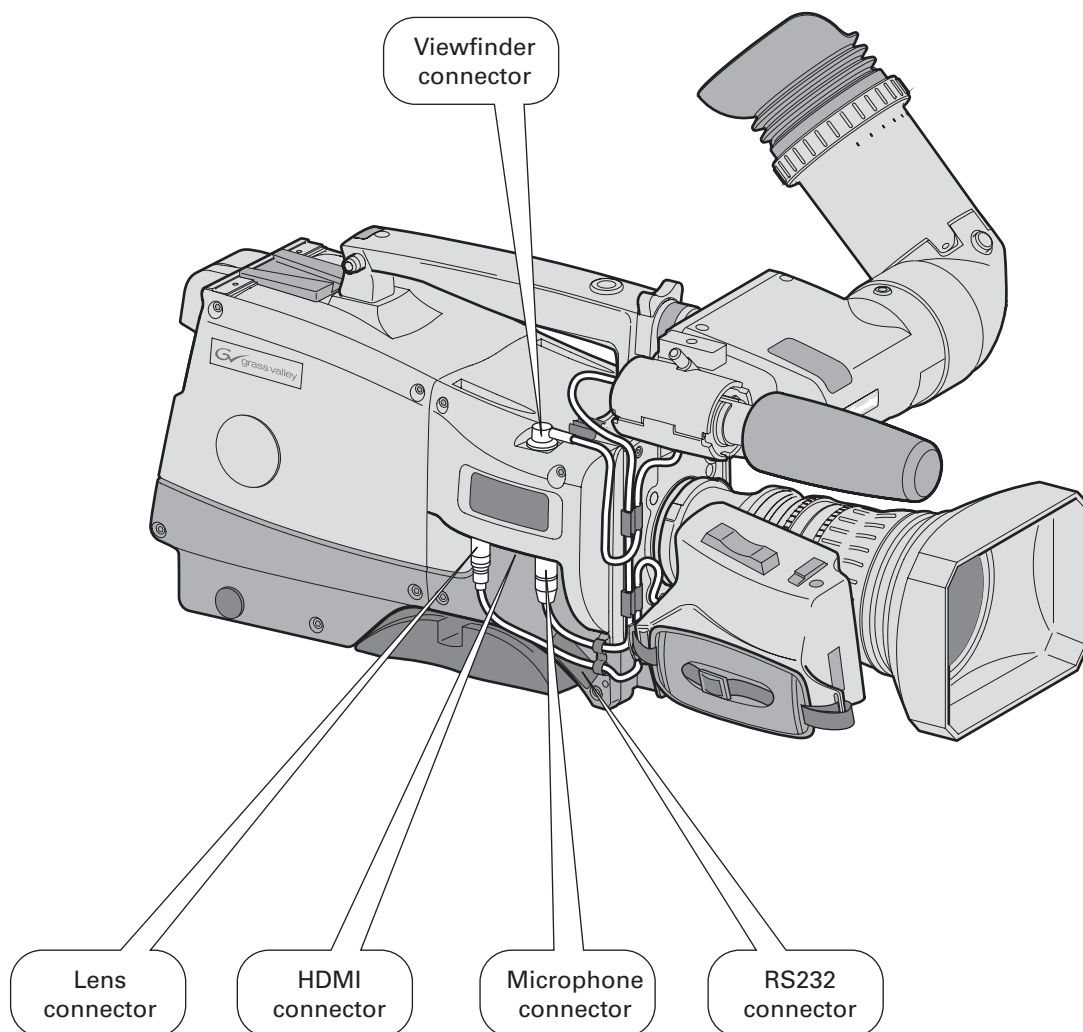

Figure 4-2. Camera head controls - front-left

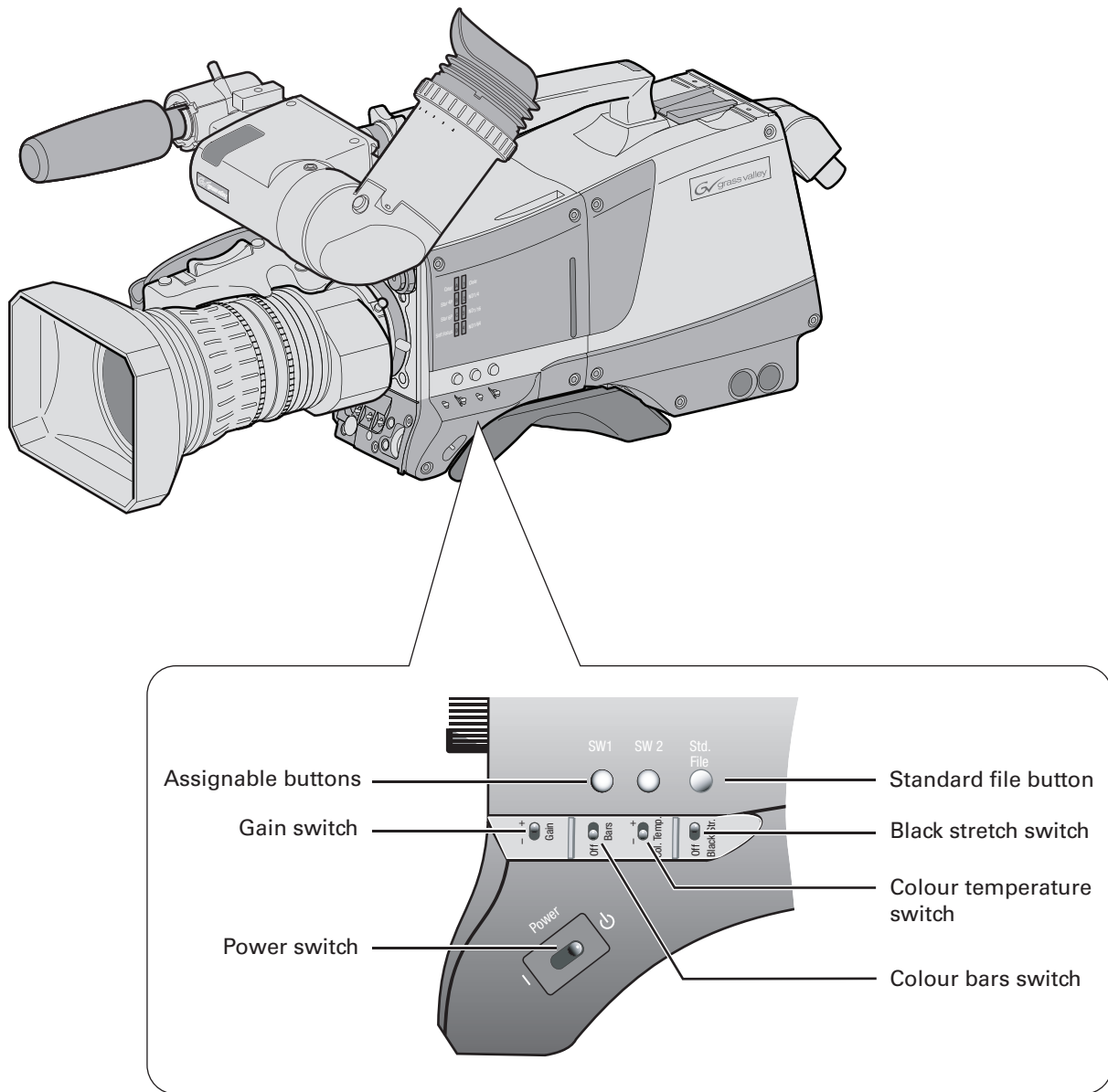
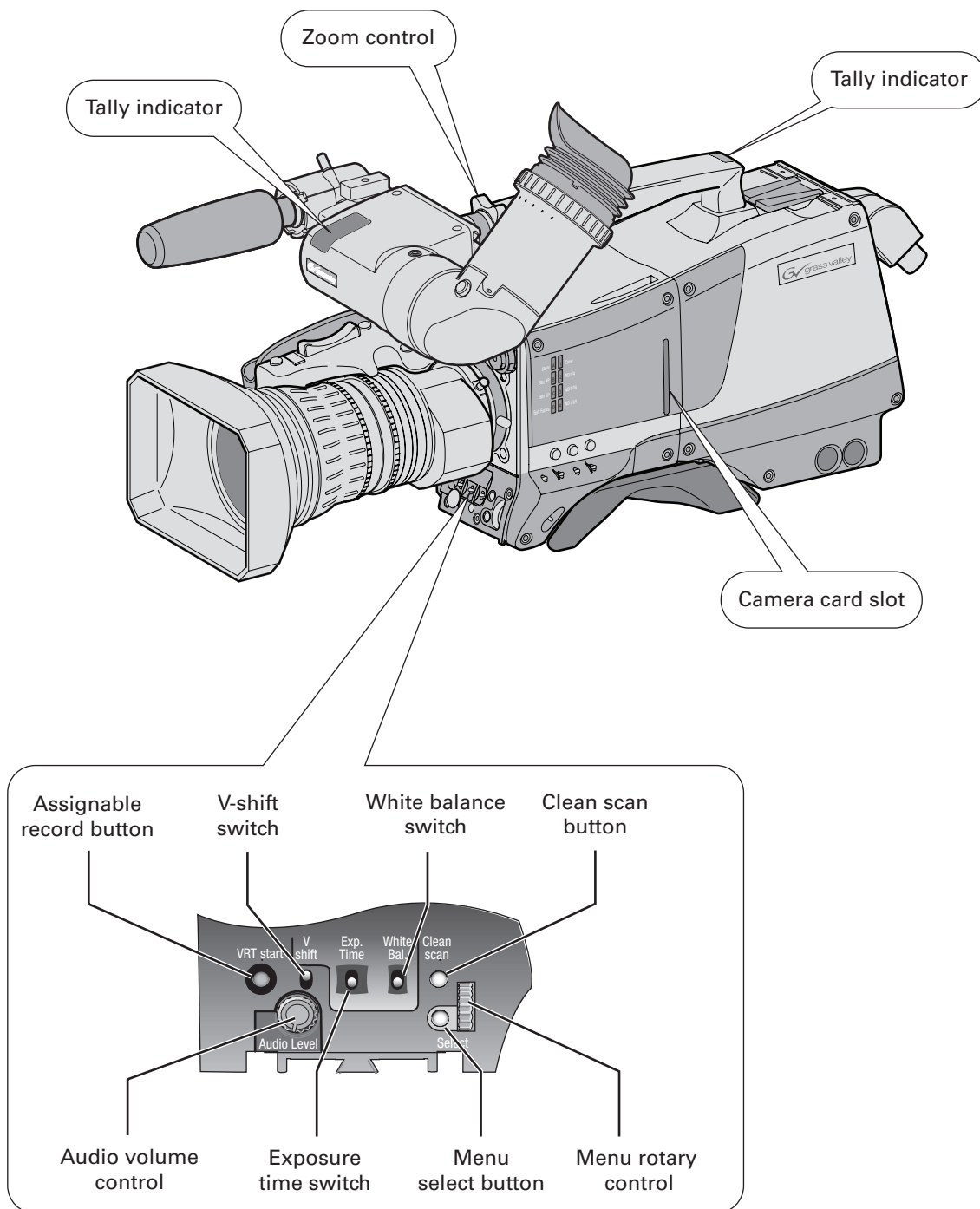

Figure 4-3. Camera head controls



4.2 TriaxHD adapter controls and connectors

Figure 4-4. TriaxHD adapter controls

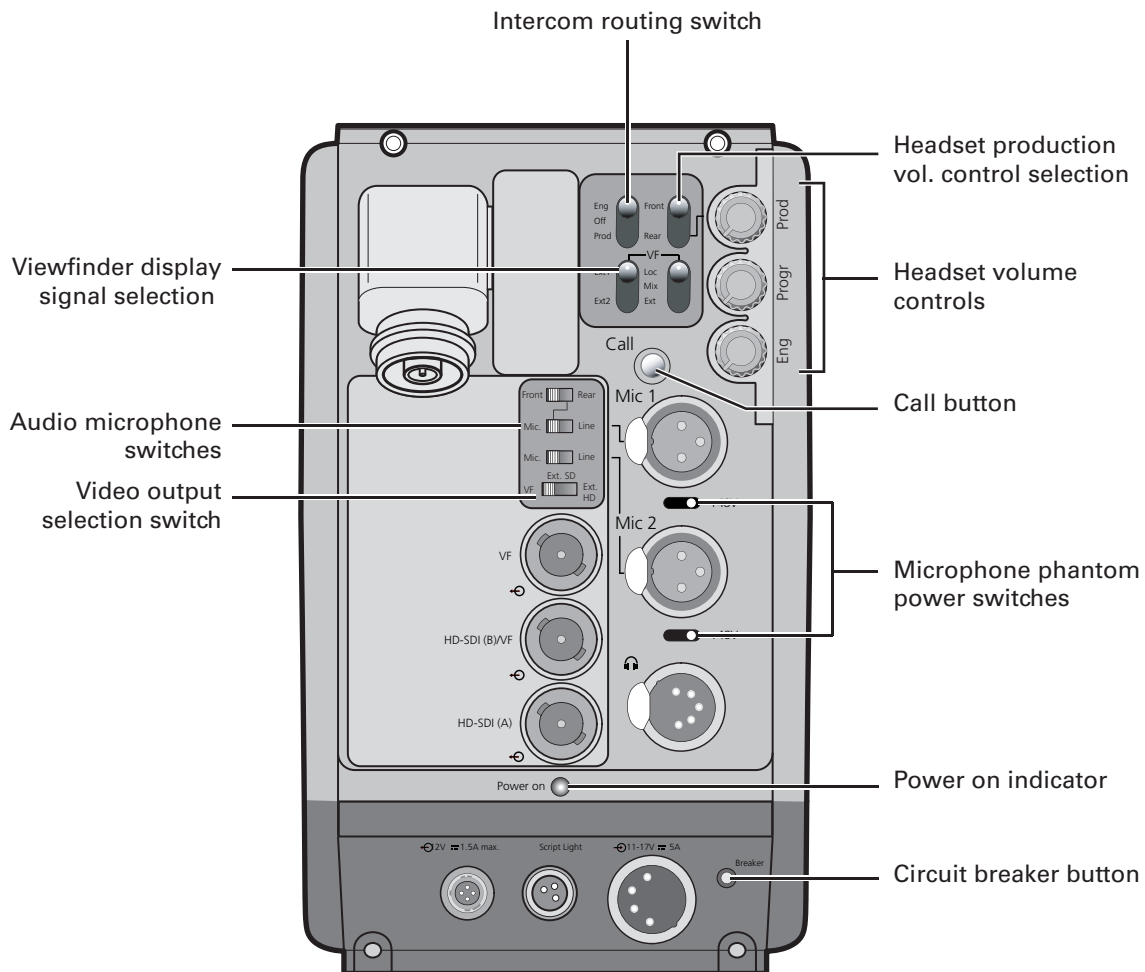
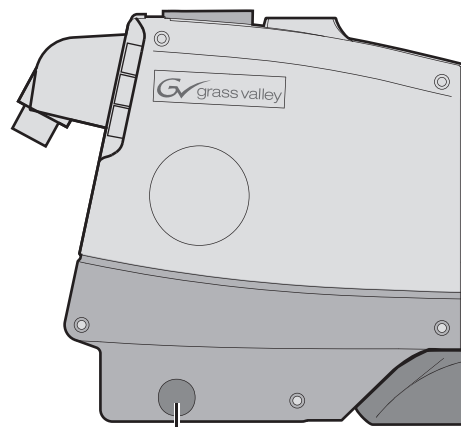
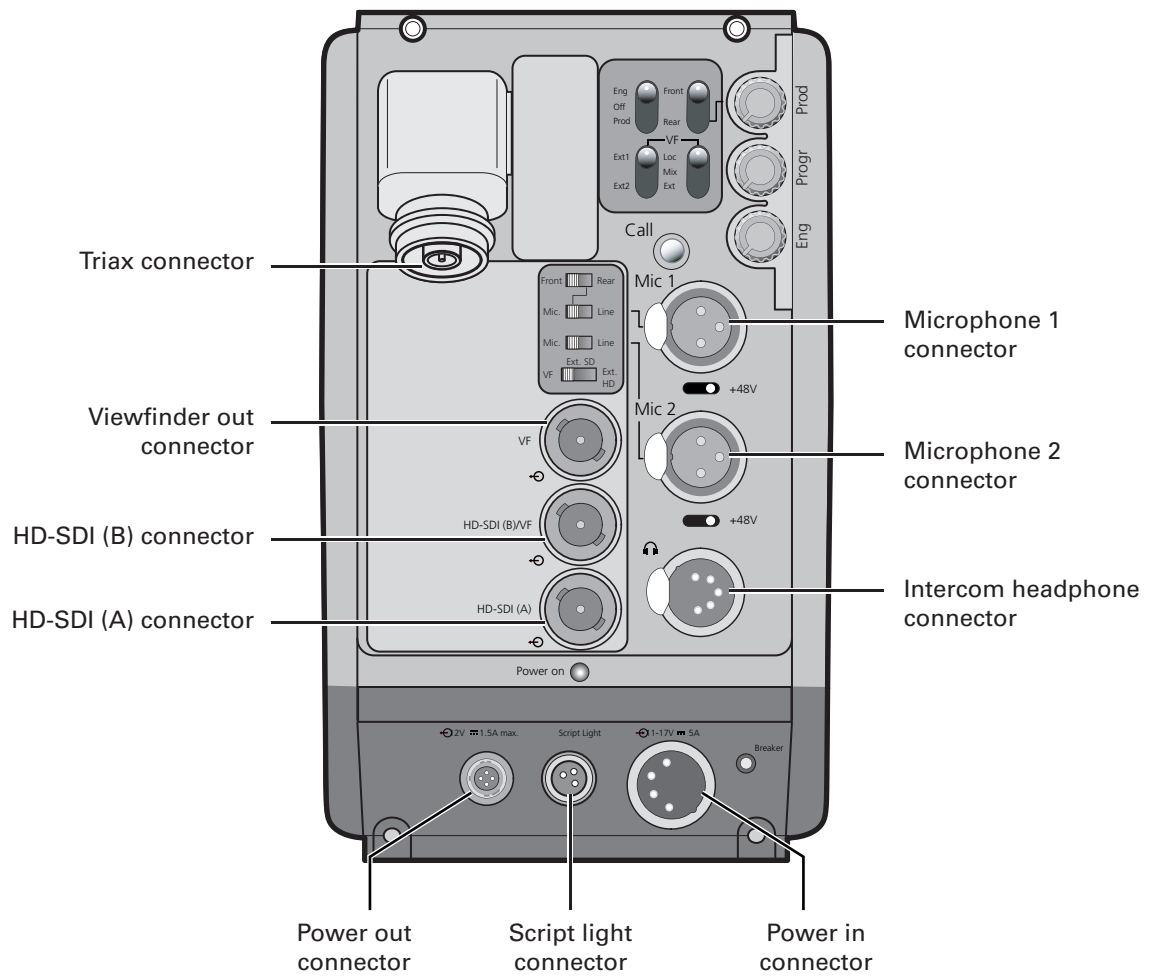
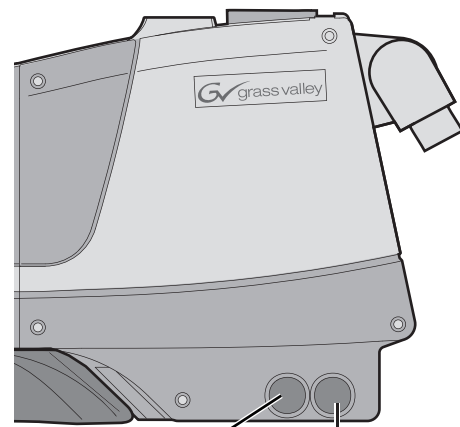

Figure 4-5. TriaxHD adapter connector location



Reference in / teleprompter out connector



Auxiliary connector Tracker connector

4.3 Viewfinder controls and indicators

Figure 4-1. Viewfinder controls

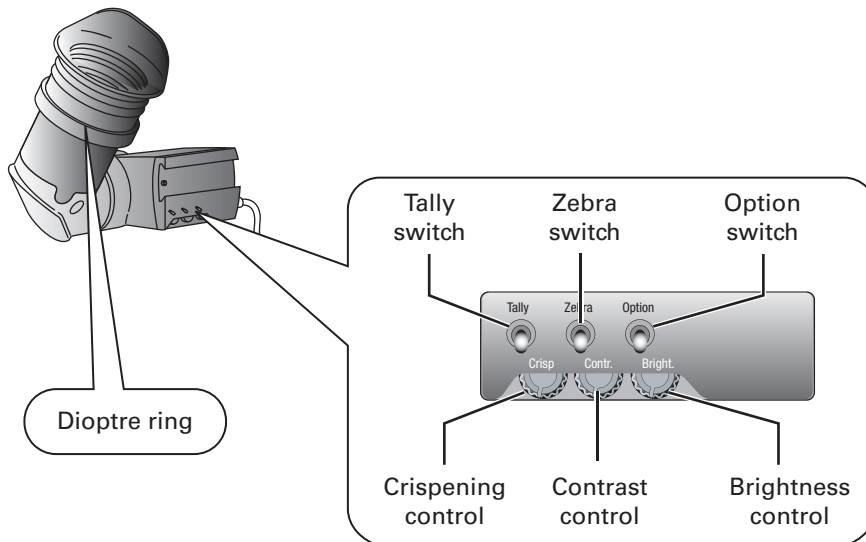
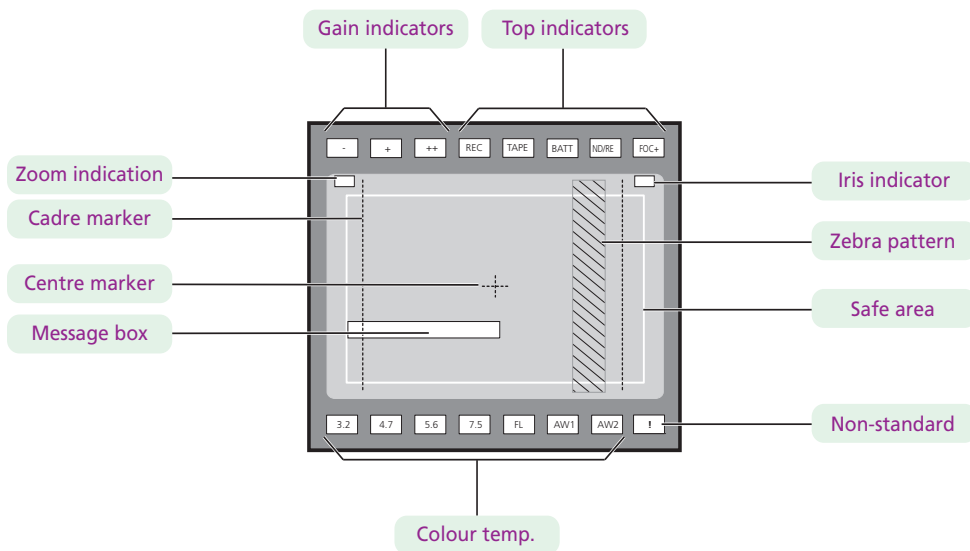

Figure 4-2. Viewfinder markers and indicators



Chapter 5

Operating instructions

5.1 Using the camera

Attach lens, viewfinder, microphone and any other accessories to the camera. Attach the triax cable or supply the adapter with power.

5.1.1 Switching on the power

1. On the Base Station set the master power switch to the on position (I). The green power light lights.
2. Set the camera **Power** switch of the camera to the on position .
3. Allow a few moments for the camera to perform a self-test and for the system to establish communications.



Note

To switch the camera to stand-by, set the **Power** switch of the camera to the  position.

5.1.2 Controlling the camera

There are several ways of controlling the camera:

- Using an OCP connected to the Base Station.
- Using the switches on the camera itself.
- Using the menu system to select functions.



Note

If you cannot access some camera functions or you wish to restrict access, refer to [Section 5.11 on page 28](#).

5.2 System Menu

The camera is operated via the viewfinder text display and the control system menu switches. The systems menu is viewed in the viewfinder and navigated by means of the **Rotary control** and the **Select button** which are both located at the front of the camera.

Figure 5-1. Menu control buttons

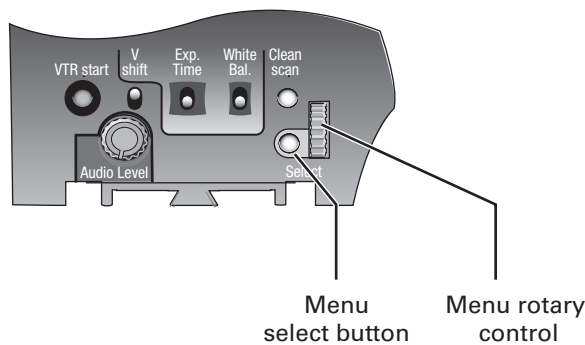

The functions of the camera are grouped into menus and sub-menus. There are seven different menus that are listed in the main menu as follows:

VF	>>
Lens	>>
Video	>>
Install	>>
Files	>>
Security	>>
Diagnostics	>>

Each of these menus gives you access to a particular group of functions. Spend some time using the controls and menus to discover the various functions. You will quickly learn to operate the camera intuitively.

Note

Some of the menu items may not appear if the user level is not set to 3.

5.2.1 Entering the System menu

Press the **Select** button after the camera is switched on, the message Menu off appears in the viewfinder. Press the **Select** button again while this text is showing, the **MAIN** menu appears in the viewfinder.

Figure 5-2. Main menu

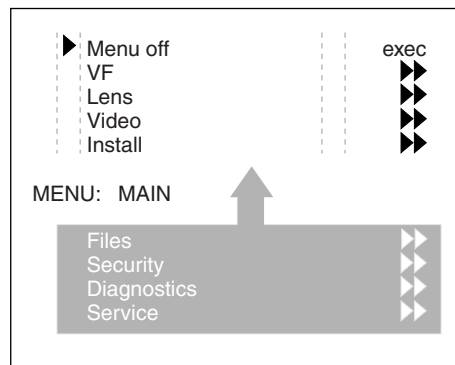

The MAIN menu screen shows five items. The name of the menu is shown below these. Four more items are hidden but become visible when you scroll down using the **Rotary control**. A cursor shows your position in the menu. The **Rotary control** moves the cursor up and down.

5.2.2 Finding your way

Use the **Rotary control** to move the cursor through the menu items. If a double arrow (>>) is visible, then pressing the **Select button** brings you one level lower in the menu system. Only five items are visible in each menu. Scroll up or down to see any additional items. When you first enter a menu (other than the MAIN menu) the cursor is positioned next to the first item.

The TOP and PREVIOUS entries are not immediately visible but are located above the first item. Use the **Rotary control** to scroll up to them.

- Select TOP to bring you back to the MAIN menu.
- Select PREVIOUS to go back to the menu that you were in before the current one.

The LENS menu, for example, shows the items displayed when you first enter the menu. The other items are available by scrolling up or down with the **Rotary control**.

Figure 5-3. Lens menu

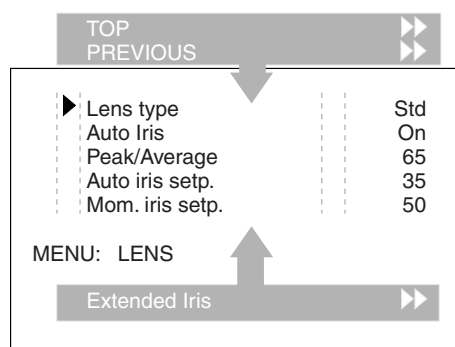

5.2.3 Leaving the System Menu

If you are deep within the menu structure, the recommended way of leaving the System menu is:

1. If necessary move the cursor to the left column with the **Select button**.
2. Scroll upwards with the **Rotary control** until the cursor points to **TOP** (this is the **MAIN** menu).
3. Press the **Select button**. The cursor now points to the **MENU OFF** item of the **MAIN** menu.
4. Press the **Select button** to leave the System menu.

If you do not use the menu it disappears after a few seconds. (This delay can be programmed in the **VF** menu.) However, when you press the **Select button** again you enter the System menu at the last position of the cursor and not at the top of **MAIN** menu. To prevent confusion the next time you enter the System menu, it is advisable to leave the menu by returning to the **MAIN** menu (**TOP**) and selecting **MENU OFF**.

5.2.4 Making changes

To find out where you have to go to change a function, consult the appendix to discover under which menu group or sub-group the function you want to change is located. If the cursor points to an item (and there are no double arrows to indicate a sub-menu) then the item pointed to has a value. The value can be:

- a toggle value (only two values)
- a list value (more than two values)
- an analogue value (variable from 00 to 99)
- unavailable (—).

If the value is unavailable it cannot be changed. This is indicated by three dashes (—). This can occur, for example, when a function is switched off. The analogue values associated with that function are then unavailable.

If there are only two values associated with the function, then pressing the **Select button** toggles between these two values. If a value is displayed next to a function that is one of several possible values, then pressing the **Select button** places the cursor in a list menu indicating the value currently selected. Use the **Rotary control** to point to a new value. Press the **Select button** to return the cursor to the function list.

If an analogue value is displayed next to a function name, then pressing the **Select button** places the cursor in front of the value and the **Rotary control** is used to change the analogue value. Press the **Select button** to return the cursor to the function list.

5.2.5 Undoing changes

If you make changes to the video settings in the Systems menu and you decide not to keep them, use the **Std. button** at the side of the camera to recall a standard set of values for the video parameters.

5.3 Assigning functions to buttons

The camera head has three assignable buttons, two on the side panel (SW1) and (SW2), and one on the lower front panel (VTR start). The operation of the zoom control button and the VTR button on the lens can also be assigned. The function and behaviour (momentary or alternating) of these buttons are set in the `INSTALL/BUTTONS` menu.

Figure 5-4. Assignable buttons

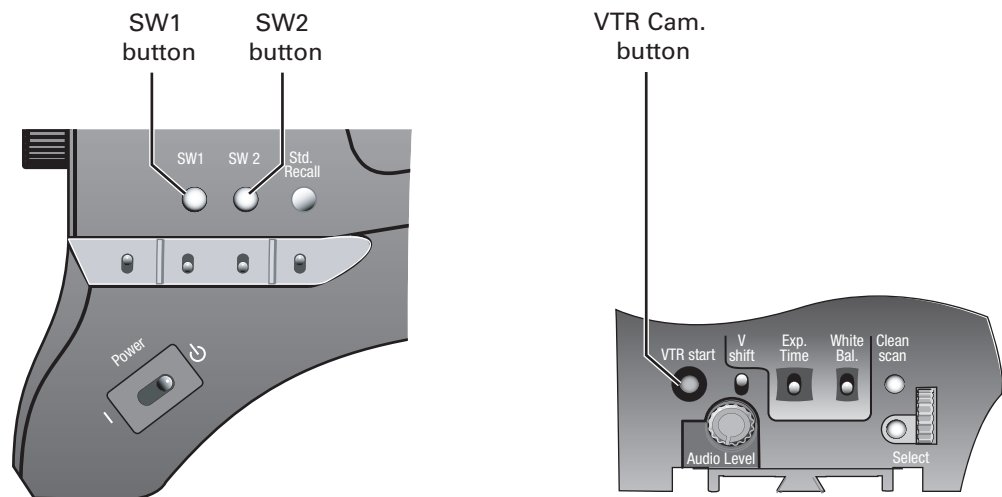

Switch	Assignments for Triax operation
SW1	Prod. intercom
	Eng. intercom
	Zoom
	Switch on external signal 1
	Switch on external signal 2
SW2	Prod. intercom
	Eng. intercom
	Zoom
	Switch on external signal 1
	Switch on external signal 2
VTR Cam.	Prod. intercom
	Eng. intercom
	Zoom
	Switch on external signal 1
	Switch on external signal 2
VTR lens	Prod. intercom
	Eng. intercom

Switch	Assignments for Triax operation
	Zoom
	Switch on external signal 1
	Switch on external signal 2
Zoom switch	Momentary
	Alternating (latched)

5.4 Video acquisition modes

In the **INSTALL** menu choose the video mode you wish to use for acquisition. The table below shows the output signals available for each model.

Camera version	Acquisition format	HDTV output	SDTV output	Viewfinder indication
1080i	1080i59.94	1080i59.94	525i59.94 (NTSC)	1080i59
1080i	1080i at 50	1080i50	626i50 (PAL)	1080i50
720p	720p59.94	720p59.94	525i59.94 (NTSC)	720p59
720p	720p50	720p50	626i50 (PAL)	720p50

5.5 Viewfinder preferences

Set up the viewfinder according to your own preferences; adjust viewing parameters, select markers, message boxes and on-screen display times in the VF menu.

Figure 5-5. Viewfinder controls

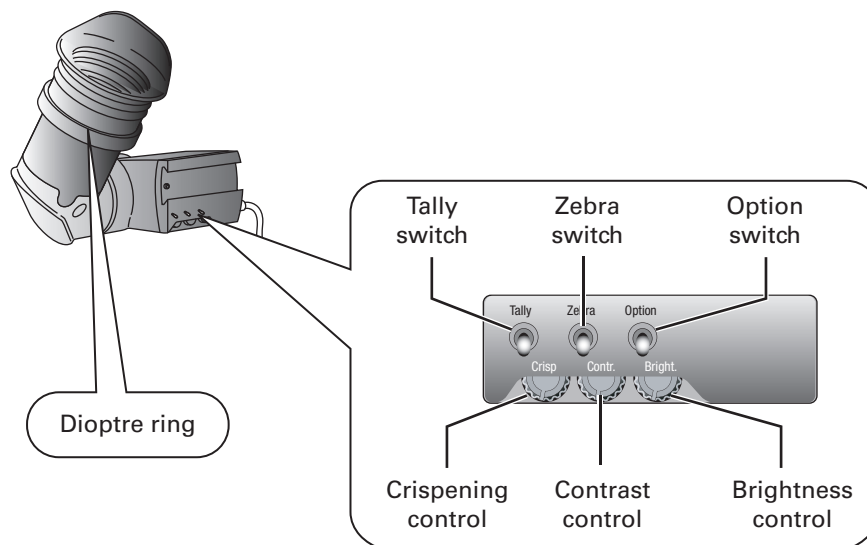

5.5.1 Viewfinder picture quality

Adjust the **Brightness** and **Contrast** controls according to your preferences. If you wish, use the **Crispening (peaking)** control to adjust the sharpness of the viewfinder picture (reduce the crispening when the gain is set to +++).

The dioptre of the viewfinder can be adjusted to suit your eyesight by turning the **Dioptre ring**. The range of the dioptre is +1 to -3.

5.5.2 Video level indication

Switch on the zebra function so that you are alerted in the viewfinder by a **Zebra pattern** in areas where high video levels occur. This diagonal line pattern warns you that the area affected has risen above a predetermined level of the full scale video exposure value. Go to the VF menu to set the video levels at which the zebra function works.

5.5.3 Tally indicators

The red **Tally indicator** at the front of the viewfinder and at the rear of the carrying handle light to indicate that the camera is on-air. The **Tally switch** is used to control the Tally indicator at the front of the viewfinder. When this switch is set to the **OFF** position, the **Tally indicator** does not light when the camera is on-air. The **Tally switch** does not control the tally indicator at the rear of the carrying handle.

When the camera is on-air, the **REC indicator** in the viewfinder lights. When the studio ISO signal is received, the **TAPE indicator** lights.

Figure 5-6. Viewfinder markers and indicators

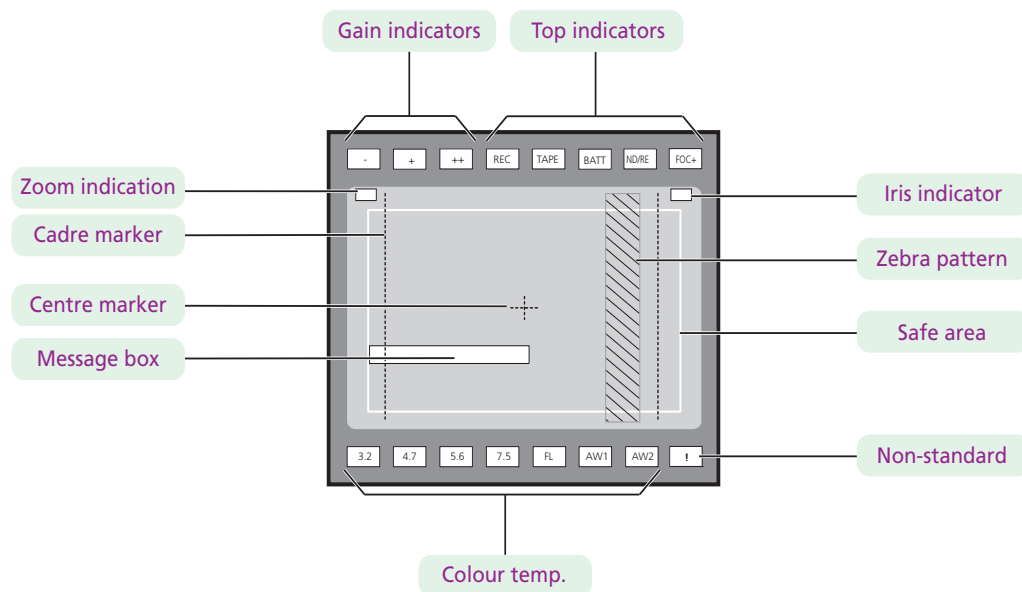

5.5.4 Viewfinder markers

Go to the VF menu to select the markers you wish to see in the viewfinder. The following markers can be set up:

- The **Safe area marker** encloses an area that represents 80% of the whole viewfinder picture area. This is the minimum area seen on a TV-set.
- The **Message box** displays information messages. The length of time this box remains on the screen is set by the Info time item of the VF menu.
- The **Centre cross** marks the centre of the picture.
- The **Cadre marker** is a dotted white line or a shaded area that shows the limits of a 4:3 (15:9 or 14:9) picture. Exterior marker shading can also be selected.

5.5.5 Focussing

A focus assist function can be switched on or off in the VF menu. This function adds motion in the viewfinder to objects in sharp focus. The **FOC+ indicator** in the viewfinder lights when this function is on.

The viewfinder zoom function is another feature that helps you focus. This function enlarges the centre of the viewfinder image. Choose one of the following buttons and the way it operates (momentary or toggle) to control this function in the INSTALL menu:

- The VTR button on the camera,
- The VTR button on the lens,
- The RET switch on a zoom control when a large lens adapter is used.

When the viewfinder zoom function is in use, many of the viewfinder markers are switched off to improve the clarity of the display. The **FOC+ indicator** in the viewfinder flashes when the viewfinder zoom function is active.

5.6 Lens preferences

When you fit a lens to the camera you may need to adjust the back focus. Refer to the lens manufacturer's instructions to find out how to do this. The **LENS** menu allows you to choose and, if necessary, adjust parameters to suit your lens type and your personal preferences.

5.6.1 Lens type

In the **LENS** menu select the lens type from two predefined settings; standard (**Std**) or wide angle (**WA**). This gives you the optimum shading settings for either a standard or wide angle lens. The lens manufacturer is also selected in this menu.

5.6.2 Auto iris

If required switch on the auto iris function in the **LENS** menu. You can also select the parameters associated with the auto and the momentary iris in this menu.

5.6.3 Extended Iris

The extended iris function automatically regulates the video signal level by adjusting the iris opening, the gain level and the exposure time to suit the ambient lighting conditions.

To switch on the extended iris function use the **Extended iris button** at the left-front side of the camera. When this button is pressed once, the current value of the automatic extended iris function is displayed. Press the button twice in quick succession to switch between on and off.

When extended iris is on, the **Non-standard indicator** in the viewfinder lights, and gain and exposure controls are blocked. The parameters for the extended iris function are set in the **LENS** menu.

5.6.4 Lens indicators

The **ND/RE indicator** in the viewfinder lights when a lens range extender is selected.

The **Iris indicator** in the viewfinder shows the value of the iris opening (when enabled in the **VF** menu).

The **Zoom indicator** in the viewfinder shows the degree to which the lens has been zoomed in or out if this feature is supported by the lens. It shows 50 if not supported.

5.7 Video preferences

The means used to control the camera depends on your work methods. A remote OCP can be used and a low user level can be selected to restrict the available camera functions.

Alternatively, video functions can be controlled on the camera itself. The following functions are available on the camera:

- Standard settings
- Test signal
- Gain selection
- Optical filter selection
- Colour temperature
- Auto-white balance
- Exposure time
- Black stretch
- Auto skin contour

Many other video functions such as contour, black, gain, knee, gamma, matrix and white limit functions are available in the VIDEO menu.

5.7.1 Standard settings

To ensure that some of the camera functions are not set to unusual values, a standard file has been defined that contains the default values for most video functions. The table in the Appendix lists the values that are set when the standard file is recalled.

To recall the standard values for the various video functions, press the green **STD button** on the left-front side of the camera and hold it for two seconds. The standard values only take effect when the camera is not on-air.

The standard file can be selected as either a factory or a customer standard file. Changing the standard file can only be done in the System security menu if the owner card or the PIN code is used.

The **Non-standard indicator** lights when the video settings are not set to their standard value, for example, when exposure is not set to nominal. It also lights when black stretch or extended iris is on and if AWC or FL is selected with the colour temperature selector.

Figure 5-7. Video control buttons

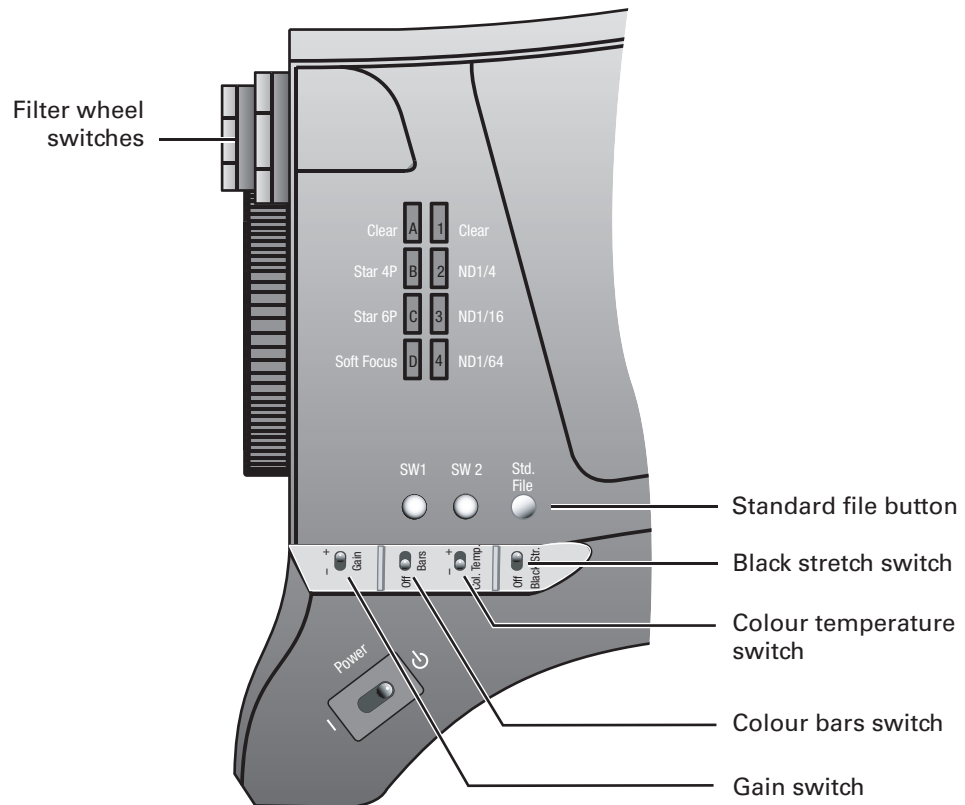

5.7.2 Test signal

The left-front side panel of the camera has a **Colour bars switch** for switching on a colour bar test signal. The colour bar is the standard test signal that is used to set up and check the camera before use. When the colour bar is selected the following functions are temporarily set to **Off**:

- Black stretch
- White limiter
- Zebra
- Safe area (VF)
- Cadre (VF)

The lens iris closes automatically when the colour bars are switched on.

5.7.3 Gain selection

Depending on the available light levels it may be necessary to adjust the gain of the camera. The gain is selected via the **Gain switch** on the left-front side of the camera.

1. When this switch is pressed initially, the current value of the gain in dB is displayed in the viewfinder.
2. Holding the switch in the up or down position for a very short period selects one of the five master gain settings: -, 0, +, ++ and +++.
 - The actual value of the gain in dB is assigned to these symbols in the `INSTALL` menu.
 - The **Gain indicators** in the viewfinder light to indicate the value selected. (The + and ++ indicators light when the gain is +++)

Symbol		Gain
-	is always	-6 or -3dB
0	is always	0dB
+	can be set to	3, 6 or 9dB
++	can be set to	6, 9 or 12dB
+++	is always	12 dB

Variable gain

The gain switch can also be used to vary the gain continuously between its minimum and maximum value.

1. Hold the switch continuously in the up or down position until you see the value in the viewfinder change in steps of 0.1dB.
2. Release the switch when you reach the value you want.
3. Using the switch momentarily again sets the gain to the nearest standard value.

5.7.4 Optical filter selection

A neutral density filter and a special effect filter can be placed in the path of the optical signal to modify the incoming light. The filters are selected via the **Filter switches** at the top-front of the camera. These filters can be used, for example, to control depth of field or exposure levels.

The camera does not need colour optical filters to be able to white balance correctly. The range of the auto-white balance is so wide (from 2.5K to 20K) that there is never any need to use colour filters to obtain the correct white. Rotate the switches to move the optical filter wheels.

The outer (bigger) filter switch has four positions:

Position	Filter
1	Clear
2	ND 1/4 filter (2 stops)
3	ND 1/16 filter (4 stops)
4	ND 1/64 filter (6 stops)

The inner (smaller) filter switch also has four positions:

Position	Filter
1	Clear
2	4-point star
3	6-point star
4	Soft focus

The status of the filter wheels is displayed in the viewfinder for a few seconds. The **ND/RE indicator** in the viewfinder lights when an ND (Neutral Density) filter is selected.

5.7.5 Colour temperature selection

For true colour reproduction the ambient lighting conditions must be compensated for by selecting a value for the colour temperature. The standard file setting is 3200K (normally used for tungsten light). Three other reference colour temperatures are available; 4700K (for outdoors, clouded conditions), 5600K (for outdoors, clouded conditions) and 7500K (for outdoors, clear blue skies).

The memory positions (FL, FL50, FL60, AW1 and AW2) are available to store the results of the auto-white measurement process. The memory positions are filled with measured values using the automatic white balance switch at the front. The FL positions are recommended for shooting with fluorescent light.

A continuous automatic white balance position (AWC) is also available. This function continuously measures the white balance and adjusts accordingly. It can be used when a constant colour balance is required under changing lighting temperatures (sunsets, indoors/outdoors use).

In the auto-white positions an electronic colour filter can be adjusted in the **VIDEO** menu. This varies the colour balance to obtain warmer or colder colour effects. When an automatic white balance process is performed, the electronic colour filter is reset to its default value.

Selecting the colour temperature

The up/down **Colour temperature switch** on the left-front side of the camera allows a choice between:

Three preset colour temperatures:

- 3200K (3.2K) - for studio lighting conditions
- 4700K (4.7K) - for outdoors, clouded conditions
- 5600K (5.6K) - for outdoors, clouded conditions
- 7500K (7.5K) - for outdoors, clear blue skies

The memory positions:

- FL - memory position for fluorescent light (matrix automatically set to CoolFL)
- FL50 - memory position for 50Hz fluorescent light (matrix automatically set to CoolFL and exposure to 50Hz.)
- FL60 - memory position for 60Hz fluorescent light (matrix automatically set to CoolFL and exposure to 60Hz.)
- AW1 - memory position 1
- AW2 - memory position 2

An automatic continuous white position:

- AWC - continuous measurement (2.5K to 20K)

When the switch is first pressed, the viewfinder displays the current value.

Select a new value by scrolling up or down through the available values.

The **Colour temperature indicators** in the viewfinder light to show which position is selected. None of these indicators light when AWC is selected, but the **Non-standard indicator** lights.

The viewfinder also displays the actual value of a measured colour temperature. The range of the auto-white balance is from 2.5K to 20K.

Variable colour temperature

The **Colour temperature switch** on the left-front side of the camera can also be used to vary the colour temperature continuously between its minimum and maximum value (2.5K to 20K).

1. Hold the switch continuously in the up or down position until you see the value in the viewfinder change in steps of 10.
2. Release the switch when you reach the value you want.
3. Using the switch momentarily again sets the colour temperature to the nearest standard value.

Auto-white balance

If the reference colour temperatures do not match your lighting conditions carry out the auto-white procedure as follows:

Figure 5-8. Auto white balance switches

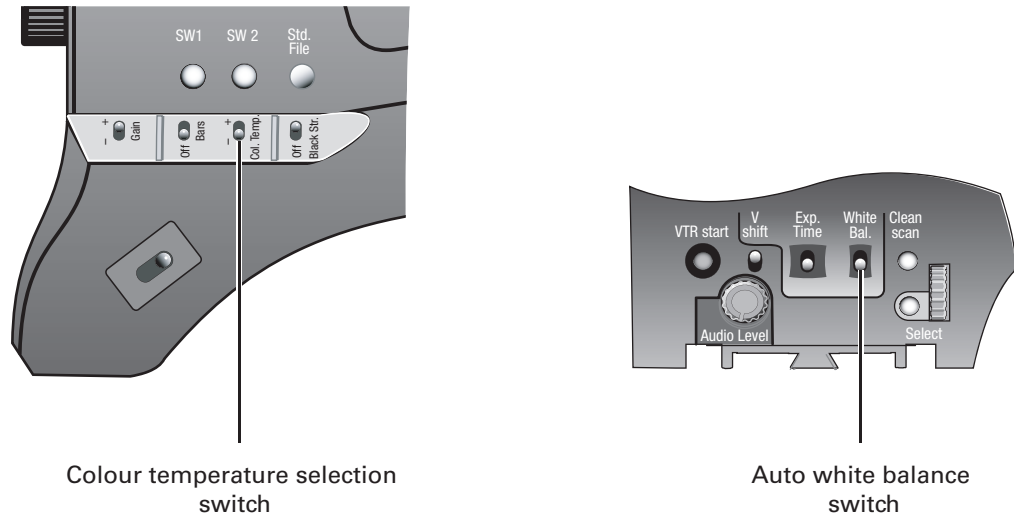

1. Use the **Colour temperature switch** to select one of the memory positions FL, AW1 or AW2 in which to store the measured colour temperature value.
2. Press once on the **White balance switch** at the front of the camera to start the automatic white balance procedure. The following appears in the viewfinder:

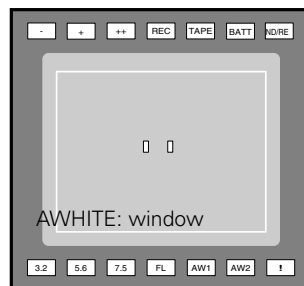

Note

If you did not select one of the memory positions FL, AW1 or AW2, the 'Precondition fail' message appears in the viewfinder.

3. Point the camera so that the reference white surface is between the two small white boxes.

4. Press the **White balance switch** again to start the measurement procedure. A message indicating that the process is running appears.

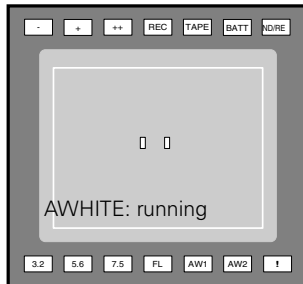
**Note**

If there is insufficient light, the 'Light level too low' message appears in the viewfinder.

5. When the process is completed (within a few seconds) the **OK** message and the measured temperature appear in the viewfinder.



The measured colour temperature is now stored in the selected memory position and can be recalled as required.

**Note**

During the auto-white measurement process iris is set to Auto and 90% and the knee is turned off.

Black balance is not necessary with this camera because of the continuous automatic black control circuits.

5.7.6 Exposure time

The exposure time values of 1/200, 1/500 and 1/1000 of a second are used to capture fast moving objects so that these can be played back sharply in slow motion. The value selected depends on the speed of the moving object.

Figure 5-9. Exposure time controls

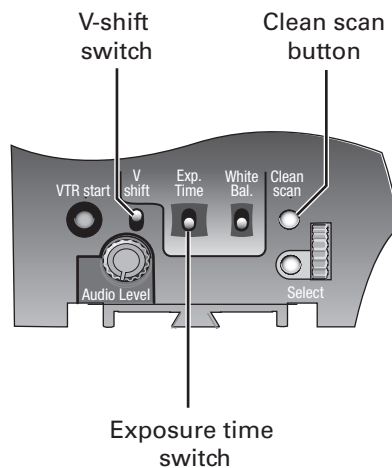

Note

Increasing the exposure speed lowers the camera sensitivity proportionally.

Selecting the exposure time

The momentary up/down **Exposure time switch** gives a choice of exposure time settings. If an exposure time other than nominal is selected, the **Non-standard indicator (!)** in the viewfinder lights.

Value	Function	Shutter blade
Nom.	- nominal setting	rotating
Var. 1	- enables the exposure to be varied	stopped
Var. 2	- enables the exposure to be varied	rotating
1/200	- for fast moving objects	rotating
1/500	- for fast moving objects	rotating
1/1000	- for fast moving objects	rotating
50 Hz	- shooting with 50Hz lighting (adjustable)	rotating
60 Hz	- shooting with 60Hz lighting (adjustable)	rotating

Lighting

The exposure selection also includes lighting control positions which can be used when shooting with lighting that is operating at a different frequency to the camera. There are two positions; 50 Hz and 60 Hz. Each of these positions can be varied further in a range from -10 to

+10. To reduce flicker select the frequency closest to the frequency of the lights and then vary the lighting control in the `INSTALL` menu to obtain the best result.

5.7.7 Shooting screens

Sometimes when shooting TVs or computer monitors a horizontal bar can be seen across these screens in the viewfinder. There are two ways of removing the noise bar from the picture depending on the frame frequency of the display:

- For displays with the same frame frequency as the camera, for example TV sets, use the V-shift facility. V-shift can also be used to remove any colour shifts that might occur when shooting pictures produced by DLP-type devices.
- For displays with a higher frame frequency, for example computer monitors, use the Clean Scan facility.

Vertical shift (V-shift)

Sometimes when shooting TV screens or monitors with the same display frequency as the camera, for example TV sets, a horizontal black bar is seen in the viewfinder because the camera is blanking while the TV is not. The **V-shift switch** shifts the camera blanking.

The **V-shift switch** at the front of the camera is spring-loaded with a central rest position. Holding the switch in the + or - position moves the bar up or down so that it is no longer visible in the viewfinder. This function is only available when the camera is used in the stand-alone mode. It is not active when the camera is genlocked or on-air.

When the camera is genlocked, use the V-shift function in the `INSTALL` menu.

Clean scan

When shooting computer monitors with higher frame frequencies than the camera use the Clean Scan function as follows to avoid horizontal bars in the picture:

1. Press the **Clean Scan button** at the front of the camera for about two seconds to directly access the variable exposure (clean scan) function. The `CLEAN SCAN` submenu appears in the viewfinder.
2. Use the **Rotary control** to change the value and so remove the noise bar.
3. If a more accurate adjustment is required set the `CL.SCAN` item to `EXTENDED`. (Set the mode to `NORMAL` if a smear effect occurs.)
4. Set the `UNIT` item to the preferred read out, **Hz** or **mSec**.

When you are finished shooting the monitor press the **Clean Scan button** for two seconds to switch off the Clean Scan function. (Exposure time returns to its previous non-variable setting.) When Clean Scan is on, the **Non-standard indicator** in the viewfinder lights.



Note

Do not shoot highlights in the Clean Scan mode as this may cause a smear effect.

5.7.8 Black stretch

The black stretch function changes the level of detail in the shadow areas of the picture without effecting the rest of the picture. Set the **Black stretch switch** to the **On** position to switch on the black stretch function.

The Video menu allows you to adjust the black stretch parameters. Black stretch values above 50 produce more detail in the shadow areas, while values lower than 50 reduce the detail (this is often referred to as Black Press). The default value is 99.

When black stretch is switched on the **Non-standard indicator** in the viewfinder lights.

5.7.9 Auto skin contour

Use skin contour to change the contour level in a selected colour range. Decreasing the contour level of a persons skin colour softens only the skin tones. But not only skin colours can be selected, for example, decrease the contour level of a soccer field to accentuate the soccer players or increase the skin contour level to accentuate a rough surface.

Carry out the Auto skin contour procedure as follows:

1. In the VIDEO\SKIN\SKIN menu, select the memory position skin 1 or 2 (not 1+2).



2. Place the cursor in front of the VIDEO\SKIN\AUTO item.



3. Press the **Select** button. The following appears in the viewfinder.

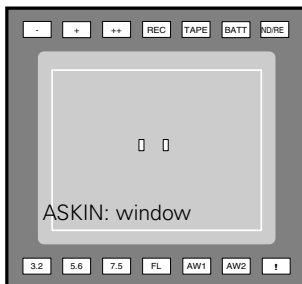

4. Point two small white boxes at the intended surface.
5. Press the **Select** button to start the measurement procedure (the iris is set to Auto). The process running message appears:

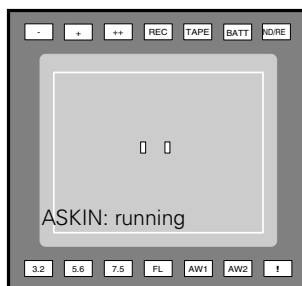

6. When the process is completed (within a few seconds) the **OK** message appears in the viewfinder.
7. Adjust the skin contour level with the VIDEO\SKIN\SKIN LEVEL item. Decrease the value below 50 to soften the selected area. Increase the value above 50 to add extra contour.

Repeat the steps for the other memory position if required. Both skin contour settings can be used at the same time. Set the menu item VIDEO\SKIN\VIEW to on to indicate the effected area.

5.8 Controls on the TriaxHD adapter

Figure 5-1. Rear controls

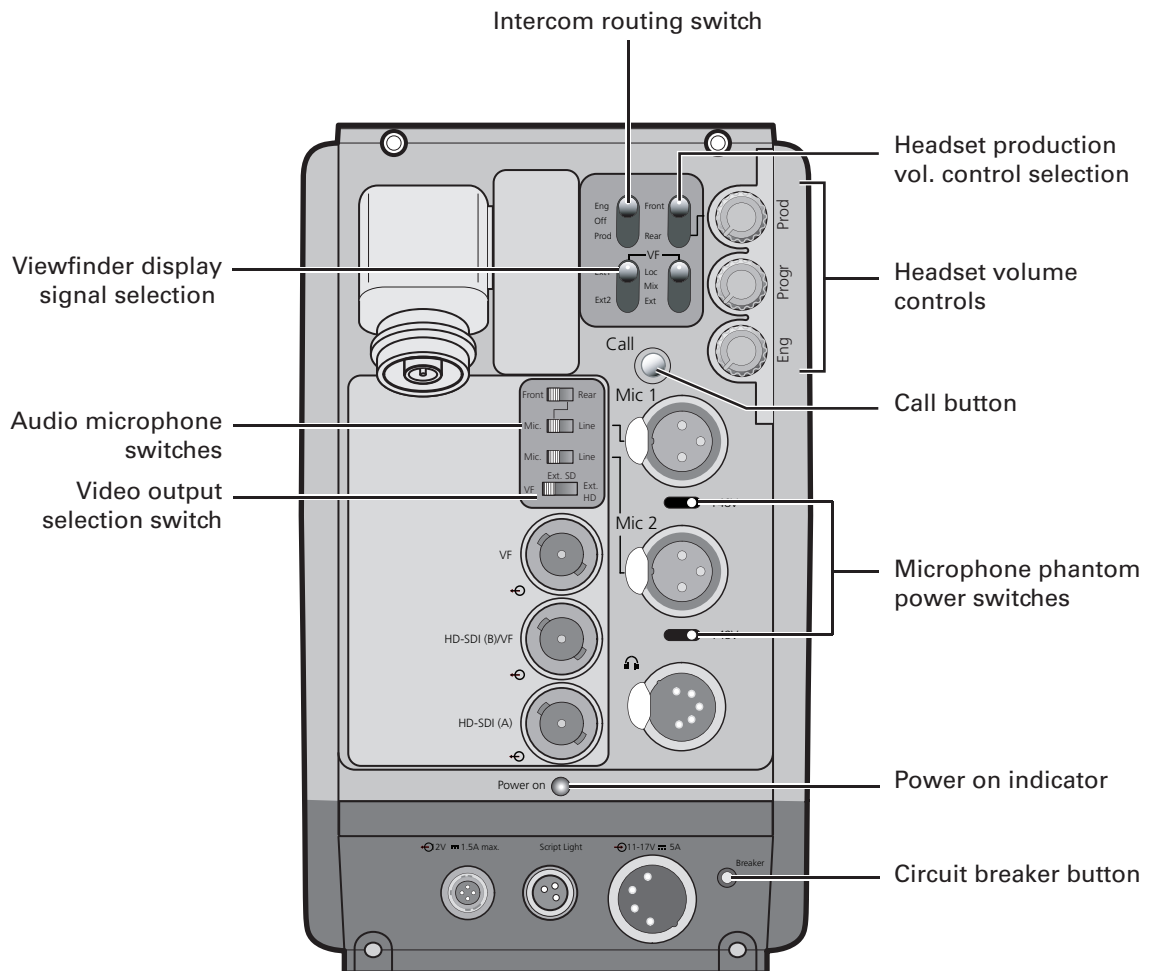

5.8.1 Powering the camera

The power supply for the camera and TriaxHD adapter is normally supplied via the Triax cable from the Base Station. The power on indicator lights when power is supplied and the camera power switch is set to the on position **I**.

When power is supplied via the Triax cable, an output power socket supplies +12 Vdc, 1.5A maximum for powering accessories.

It is also possible to operate the camera without a Triax cable by supplying a +12 Vdc supply to the DC input socket. The BATT indicator in the viewfinder lights if the camera supply voltage is less than 11V when using an external supply.

If excessive current flows in the camera or adapter, the circuit breaker trips and shuts off power to all the units. If this happens check the units for faults and if necessary take corrective action before pressing the circuit breaker button to reset the power.

5.8.2 Selecting monitoring signals

Viewfinder display signal

The viewfinder can display local or external video signals. Two switches determine the signal that is displayed in the viewfinder. The selection made with these switches also determines the VF connector output. Viewfinder display signal switch:

- Set to LOC to display the local camera Y signal in the viewfinder.
- Set to MIX to display a mix of the local camera Y signal and external signal.
- Set the switch to EXT to display the external signal 1 or 2.

The external signal selection switch determines which external signal from the Base Station, either EXT1 or EXT 2, is displayed in the viewfinder.

Figure 5-10. Viewfinder signal display switches

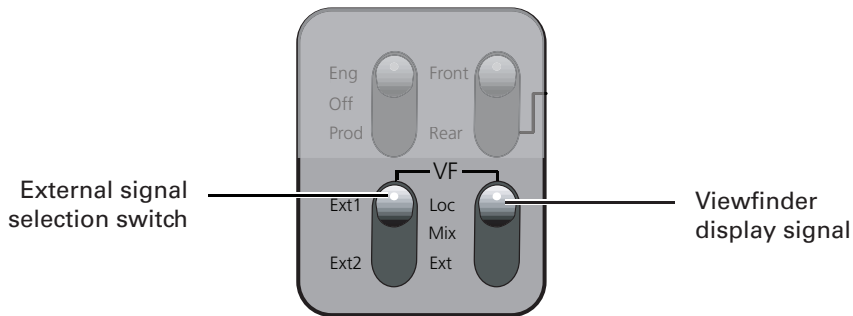

Output monitoring signal

The monitoring output selection switch determines the signal available at the VF output connector. The output can be switched between:

- VF: the analog viewfinder signal (Y only),
- Ext SD: the external signal from the base station (SD-format, CVBS). or
- Ext HD: the scaled external signal from the base station (HD-format, Y only).

Figure 5-11. VF output connector signal

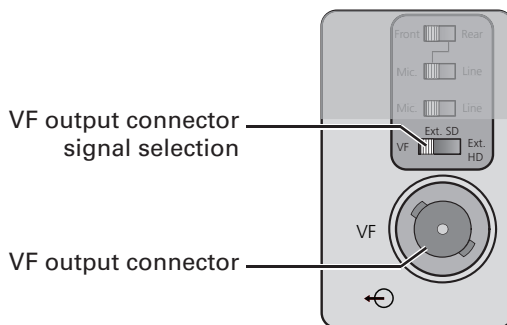

5.8.3 Using audio

Two high quality audio channels are available in the Triax mode. Set the gain levels (-22 to -64 dB) for these channels in the **AUDIO** section of the **INSTALL** menu. A high-pass filter for each channel can also be switched on via this menu.

Audio channel 1

The channel 1 input socket selection switch selects either:

- the socket at the front-right of the camera, or
- the **Mic 1** audio channel 1 connector at the rear of the adapter

as the input for channel 1.

The rear input level switch selects either a line level input or a microphone level input for the channel 1 rear connector. The line level input sensitivity is 32dB lower than the microphone input sensitivity.

The switch under the **Mic 1** socket selects a phantom power supply (48V) for the rear socket. Phantom power (48V) is always present on the front-right microphone socket.

Figure 5-12. Audio channel switches

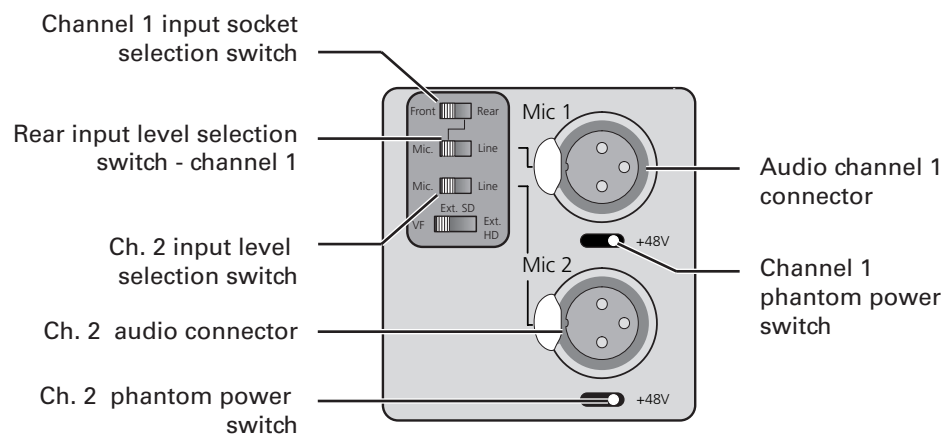

Audio channel 2

The channel 2 rear input level switch selects either a line level input or a microphone level input for the channel 2 rear connector (**Mic 2**). The switch under the **Mic 2** socket selects a phantom power supply (48V) for the rear socket.

5.8.4 Intercom

Three intercom channels – production (Prod), programme sound (Prog) and engineering (Eng) – are sent from the Base Station to the camera operator's headset. The camera operator's intercom microphone signal is sent to the Base Station. Routing and volume controls for the intercom are on the back of the adapter.

Figure 5-13. Intercom controls

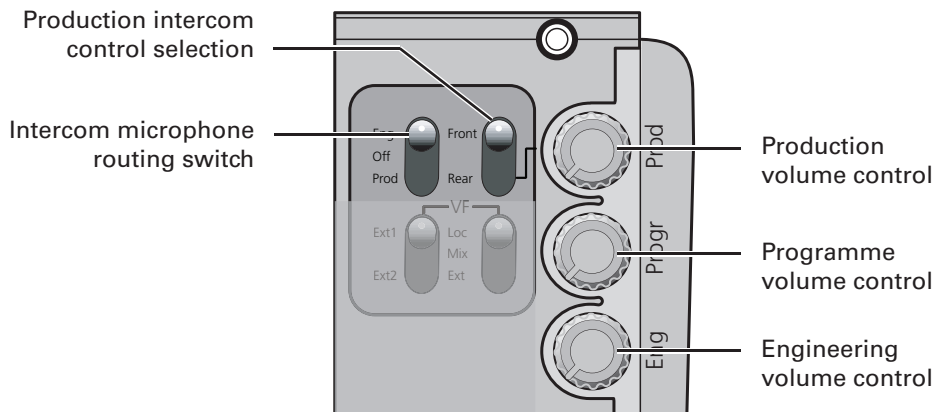

Production intercom volume control selection

Use this 2-position switch to control the volume of the production signal in the intercom either at the front of the camera or at the rear of the adapter.

Intercom microphone routing switch

This 3-position switch routes the camera operator's intercom microphone signal to engineering (Eng) or production (Prod), or turns it off. The VTR Start button at the front of the camera, or the VTR button on the lens, can be assigned to send this intercom signal to production, regardless of the position of this switch.

Intercom headset volume controls

- **Prod** - adjusts the volume of the production signal to the camera headset when selection switch is in the **REAR** position.
- **Prog** - adjusts the volume of the programme signal to the camera headset.
- **Eng** - adjusts the volume of the engineering intercom signal to the camera headset.

The **INTERCOM** section of the **INSTALL** menu contains various settings for all these channels. Signals for left and right headset muffs and sidetone levels can be selected. Intercom microphone amplification levels, phantom power supply and microphone on/off switches are also available in this menu.

Tracker intercom

A tracker can connect a headset to the side of the adapter to receive the intercom channels from the Base Station and the camera operator's microphone signal. The tracker's microphone signal is passed to the camera operator and to the Base Station.

5.8.5 Communication

Call button

Press this momentary button to send a signal to the control panels calling for attention. The ND/RE indicator in the 1.5-inch viewfinder shows when a call signal is sent or received.

The call button can also be used to playback a voice mail message that has been recorded in the Base Station. Press once to start playback; press again to stop.

Data channel

The Aux connector on the side of the adapter provides analogue control signals and allows for the connection of a two-way private data channel between camera and Base Station. In the `INSTALL` menu, the tracker microphone and engineering intercom channels can be selected to carry the private data instead of their normal function.

Tracker tally signal

The tracker connector on the side of the adapter, as well as providing full intercom facilities for the dolly or crane driver, also carries a tally signal and a +12 Vdc power supply. This allows an external on-air lamp to be used.

5.9 Managing files

You can have access to 15 different files. This number can be extended by using additional scene file camera cards. The Files menu is used to recall and store these files. There are two types of file:

- scene files
- operator files

A scene file contains values related to the picture performance. The operator file contains values related to the set-up of the camera (viewfinder, lens and installation parameters). The tables in the Appendix indicate the functions that are stored in the scene file and those functions that are stored in an operator file.

5.9.1 Scene files

Four scene files are stored in the camera itself (SCAM1, SCAM2, SCAM3 and SCAM4). Another four scene files can be stored on the camera card (SCARD1, SCARD2, SCARD3 and SCARD4). A STANDARD scene file (preselected as either factory or customer defined) is stored in the camera.

 **Note**

The standard customer scene file is stored via the SECURITY menu, not the FILES menu. The decision to use the factory defined file or the customer defined file as the standard file is also made in this menu.

The FILES menu enables the scene files to be stored and recalled using the store and recall entries of the menu system. If the message NOK is displayed, then the old values are restored. If the camera is on-air when a scene file is recalled, then the recalled values do not become active until the camera goes off air.

5.9.2 Operator files

The FILES menu also allows the recall of the operator file stored in the camera (OCAM1) or one of the two operator files (OCARD1 and OCARD2) stored on the camera card. These files contain information for setting up the non-video configuration of the camera. A STANDARD operator files (factory or customer defined) is stored in the camera.

 **Note**

The standard customer operator file is stored via the SECURITY menu, not the FILES menu. The decision to use the factory defined file or the customer defined file as the standard file is also made in this menu.

5.9.3 Standard files

The green **STD button** on the left-front side of the camera recalls the standard scene file. This file contains standard parameters for the picture performance. A standard operator's file can be recalled via the **FILES** menu. This file contains parameters for the set-up of the camera.

5.9.4 Customer standard files

You can define a customer standard file for the standard scene file and for the standard operator's file. The contents of the customer files for both these standard files is stored via the **SECURITY** menu. The selection of a factory defined or a customer defined file for use as a standard file is also made in this menu. You can only access the functions of the **SECURITY** menu with an owner's card or the PIN code of the camera.

5.10 User levels

The user level function in the **SECURITY** menu restricts access, in varying degrees, to the operational controls of the camera. You can only access the functions of the **SECURITY** menu with an owner's card or the PIN code of the camera.

5.10.1 Selecting the user level

There are four user levels: user0, user1, user2 and user3. The purpose of the user levels is to restrict the set of functions which can be changed by whoever is using the camera. In this way a more centralized and uniform control can be achieved and the danger of the camera operator accidentally changing critical functions while shooting is reduced.

User level 0 is a special protection level which locks most of the operational controls of the camera. Use this level to ensure that a camera that has been set-up is not tampered with. User level 0 is not normally used for operational purposes as it is too restrictive for normal circumstances. The recommended minimum user level is 1. For full control set the level to 3. When you switch off the power, the access rights that were obtained by the use of the PIN code are disabled and the camera starts at the assigned user level when switched on again.

Disable camera

The disable camera function is a protection function which prevents unauthorised interference with the camera and provides an additional level of security. Setting disable camera to **ON** is similar to using User level 0 to protect the settings of the camera.

5.11 Access and Security

5.11.1 Camera cards

Three camera cards are delivered with each camera. These comprise of two user's cards and one owner's card.

Figure 5-14. Camera cards

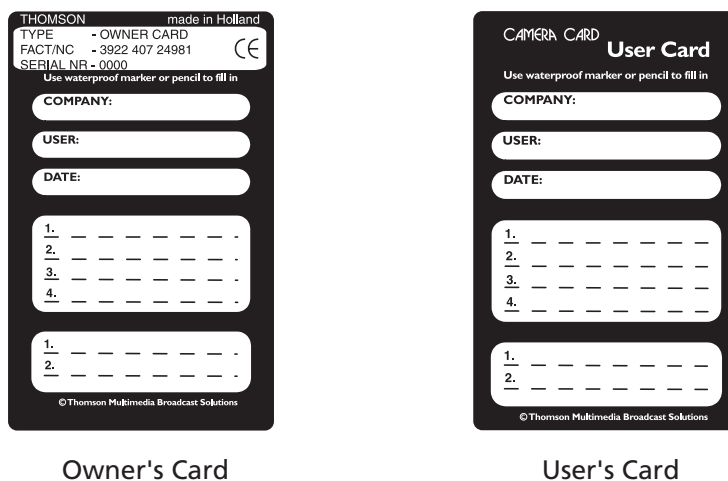

The owner's card has three functions:

- As an access control device to the security settings of the camera.
- As a storage device for four scene files.
- As a storage device for two operator files.

The owner's card is unique to every camera. Owner's card and camera must have the same serial number. An owner's card is linked to the serial number of the camera and cannot be used as an owner's card for another camera.

The user's card has two functions:

- As a storage device for four scene files.
- As a storage device for two operator files.

Scene files

Both the user's card and the owner's card allow four different scene files to be stored on the card. The recall and storage of a scene file is carried out via the Files menu of the menu system. A scene file contains information relating to the video settings.

Operator files

Both the user's card and the owner's card allow two different operator files to be stored on the card. The recall and storage of a operator file is carried out via the Files menu of the menu system. An operator file contains information relating to the set-up of general camera preferences.

5.11.2 Access control

The owner's card or the PIN code is used to access special set-up and security features of the camera. Inserting the owner's card into the associated camera always gives direct access to the Security menu (PIN code is not required). If you select the Security menu without this card inserted, you must enter the correct PIN code to gain access to this menu.

PIN code

The PIN code of the camera can be viewed and changed in the Security menu. The camera's PIN code when it leaves the factory is set to 0000. It is strongly advised that this code be changed by the owner on receipt of the camera. This ensures added protection against unauthorised access to the Security menu.

5.11.3 Camera card slot

Insert your camera card into this slot with the chip on the card facing the front of the camera. Push the card home until it fits snugly. A camera card is not required for normal operation of the camera.

Figure 5-15. Camera card slot

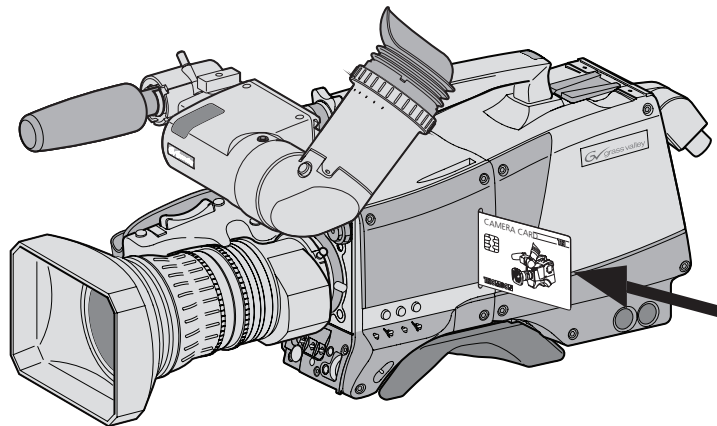

Note

Only use an original camera card. Store the owner's card in a safe place.

5.12 Smart-Touch™ option

Smart-Touch is an optional software module that gives immediate access to 14 pre-defined scene files. This library allows you to quickly set up the camera for different shooting conditions. To choose a particular file proceed as follows:

1. Press the green **STD button** for 2 seconds; the viewfinder shows the library of available shooting conditions.
2. Select a file by turning the **Rotary control** at the front of the camera.
3. Activate the file of your choice by pressing the **Select button** at the front of the camera.

The new values only take effect when the camera is not on-air. The Smart-Touch files can also be selected by navigating to the **FILES** menu using the System Menu. The files of the Smart-Touch library are divided into three categories, Lighting, Creative, and Matching, which complement the standard setting scene file.

The Lighting category provides three different files for various lighting conditions:

- **Night** optimises the transfer characteristic to enhance the visibility of detail in very dark scenes without the undesirable consequence of excessive noise associated with simply increasing gain.
- **Fluorescent** establishes matrix and colourmetric parameters to reduce the green tinge and give a more acceptable picture when the scene is lit with uncorrected fluorescent lighting.
- **Extreme contrast** uses the full dynamic range of the FT CCD sensor to obtain better handling of highlights and more detail in the shadows.

The Creative category provides seven files for different effects:

- **Sports warm colour** delivers warm and rich contrasts bringing out team colours.
- **Sports interview** incorporates the dual skin tone control into the sports setting for interviews.
- **HI film** gives a high contrast film-like look which is ideal for outdoor location production.
- **HI film + skin** is the HI film setting with dual skin tone control incorporated for natural, flattering close-ups.
- **LO film** gives a low contrast film-like look for studio production.
- **LO film + skin** is the LO film setting with dual skin tone control incorporated for natural, flattering close-ups.
- **Sepia** creates a sepia tone look for atmosphere-rich production.

The Matching category provides three files for camera matching:

- **LDK9x + LDK10** for matching to Philips LDK9, LDK10, LDK90 and LDK91 cameras.
- **DVW xxx** for matching to Sony cameras.
- **HL xxx** for matching to Ikegami cameras.

Each of these settings can be personalised and stored on a smart card.

Chapter 6

Menu structure and contents

6.1 Menu structure

The structure of the main menus and their submenus are shown on the following pages. The first column shows the user level (0 to 3). You only see menu functions whose user level is equal to or less than the user level set on your camera. Where appropriate, the default value of the function in the standard factory file is shown after the function.

6.1.1 Top menu structure

Viewfinder (VF) menu	>>
Lens menu	>>
Video menu	>>
Install menu	>>
Files menu	>>
Security menu	>>

Viewfinder (VF) menu - contains the functions which determine how items in the viewfinder are displayed.

Lens menu - controls various aspects of the lens.

Video menu - contains those functions which affect the picture quality.

Install menu - contains the functions that are used to set up the general configuration of the camera. It also contains controls to customize those switches that are directly operated on the camera.

Files menu - allows values to be stored in scene and operator files, and allows these files to be recalled as required.

Security menu - used by the camera owner to set user levels and to control access to the camera, or to store the customer (scene and operator) default files.

Diagnostic menu - provides information on the current status of the camera. No values can be changed in this menu.

6.1.2 Viewfinder menu structure

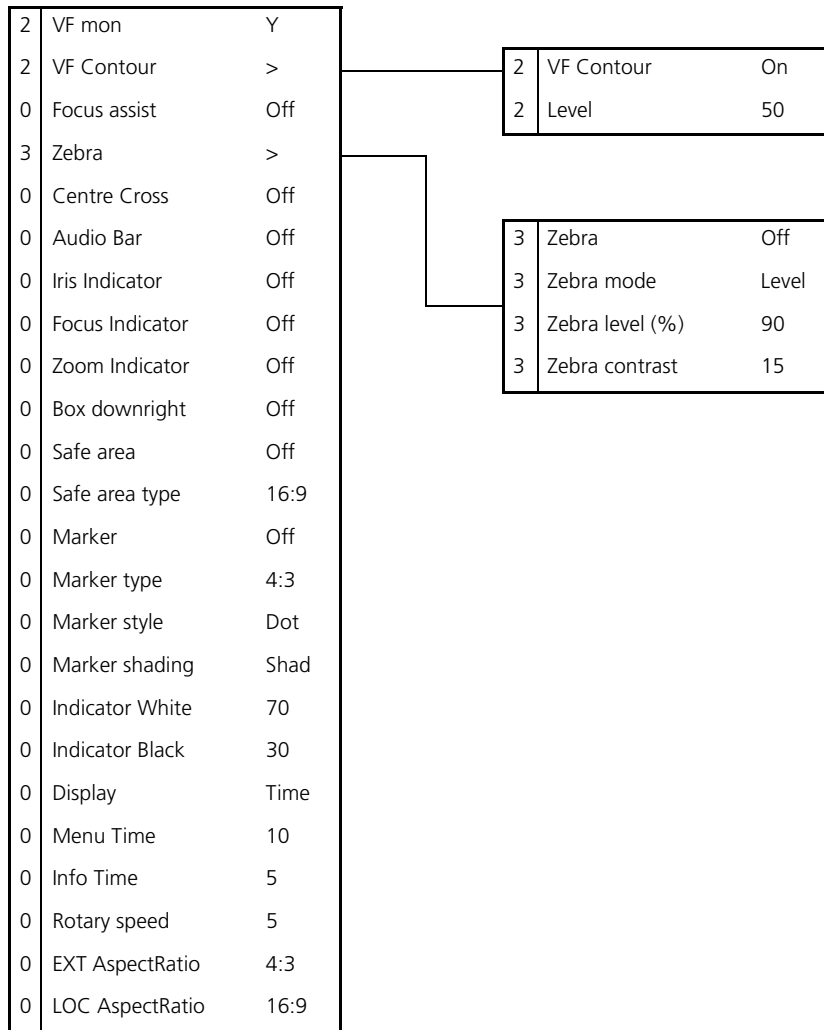

6.1.3 Lens menu structure

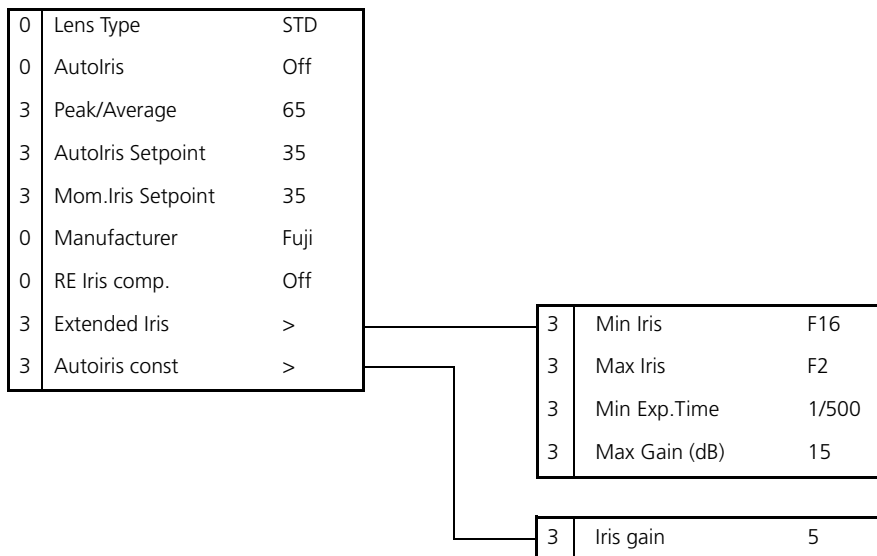

6.1.4 Video menu structure

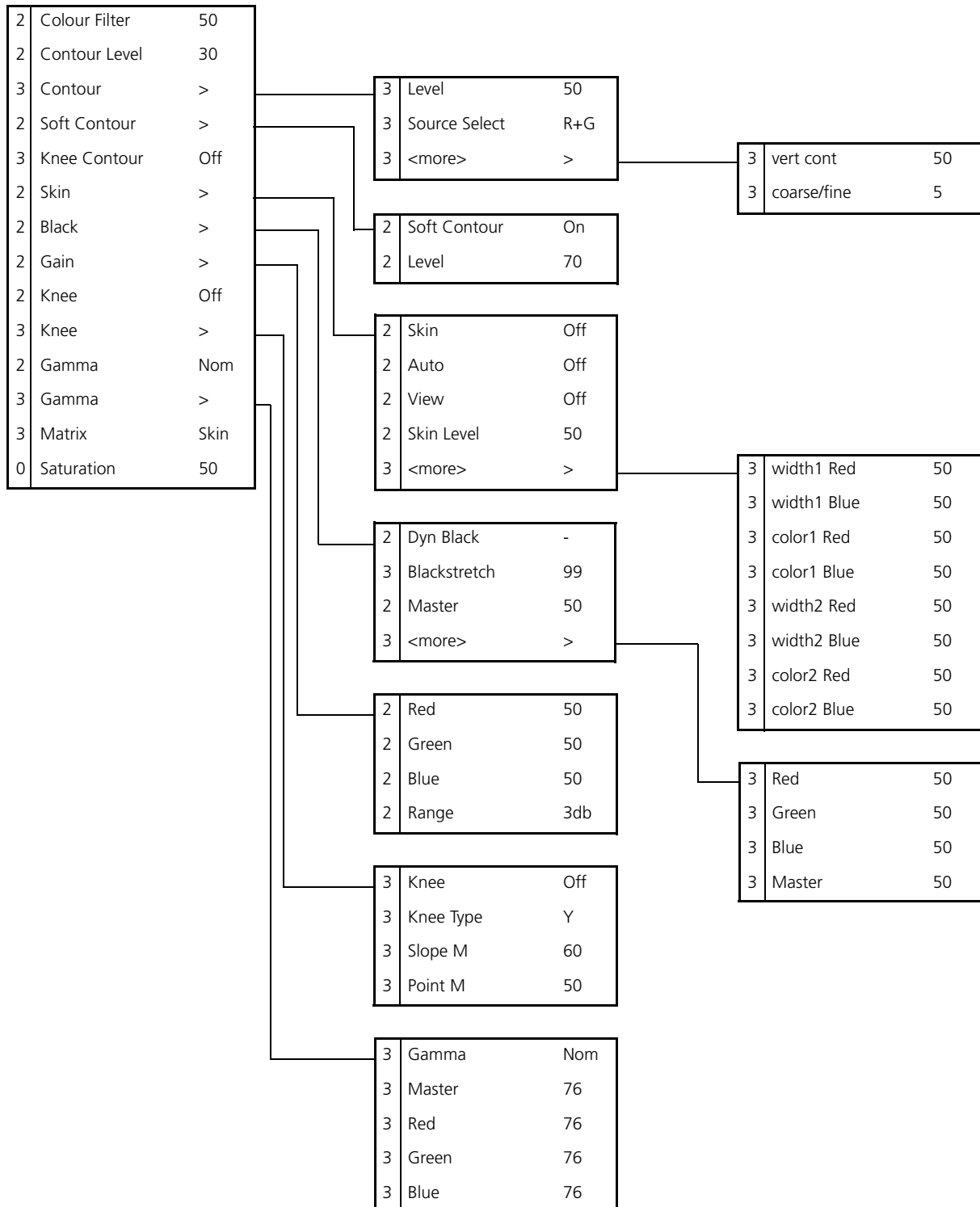

6.1.5 Install menu structure (HDTriax)

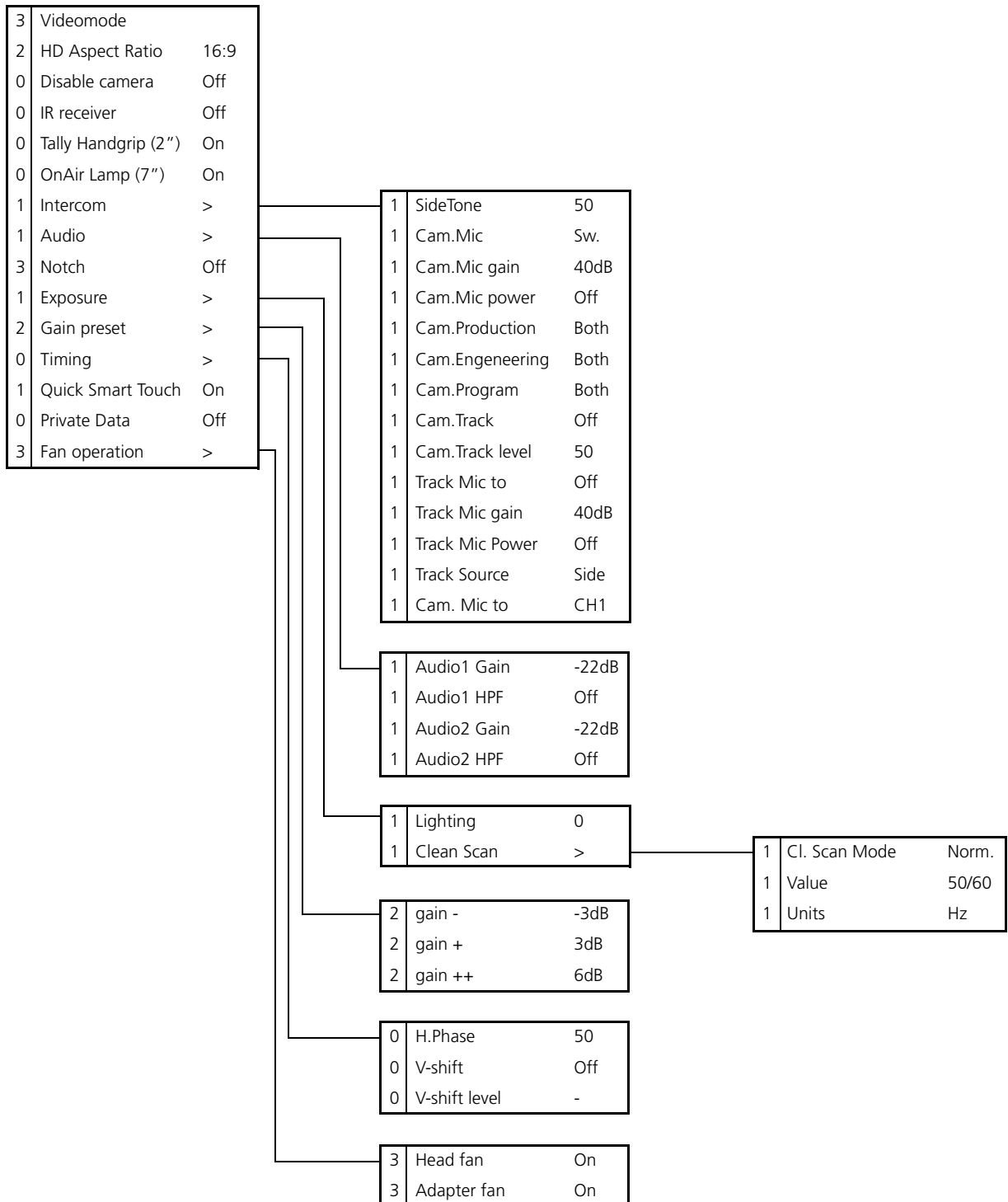

6.1.6 File menu structure

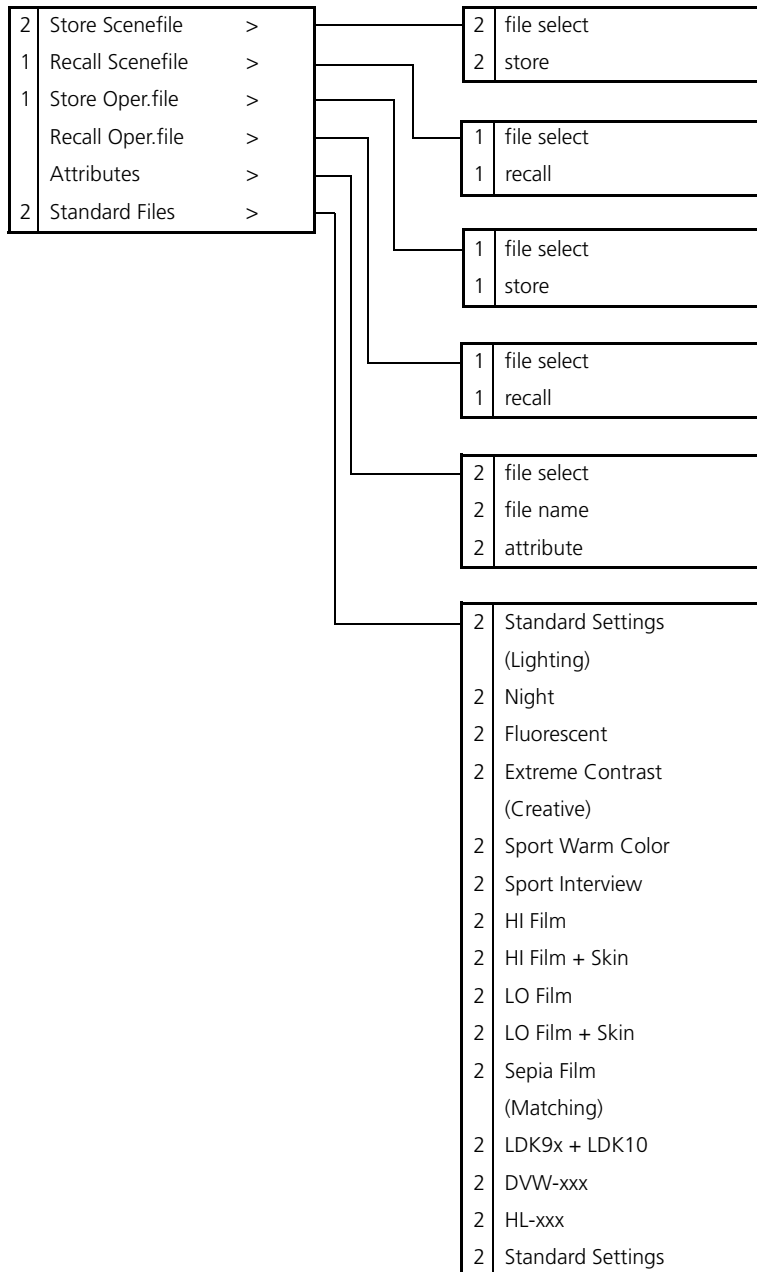

6.1.7 Security menu structure

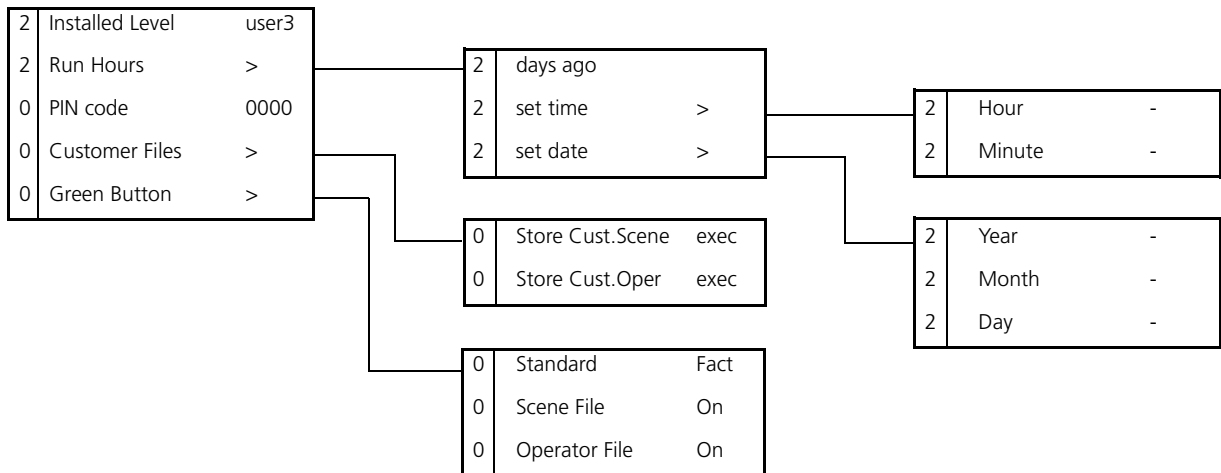

6.2 Menu contents

The number (0, 1, 2 or 3) in the LEVEL column indicates the user level at which this item is visible in the menu; items with numbers higher than the user level that is set on the camera are not visible in the menu. For example, if user level 2 is set, items marked with a 3 are not visible.

- If an item is not relevant it is not visible in the menu;
- The Sc. in the FILE column indicates that the value of this item is stored in the Scene file; the Op. indicates that the value of this item is stored in the Operator file.
- In the VALUES column, the default value of the item is shown in **bold**.

Note

The items available in the camera menu depend on the version of the software loaded in your camera. The software version used to reproduce the menu items in this manual may differ from that of your camera.

6.2.1 Viewfinder menu contents

MENU	VALUES	DESCRIPTION	LEVEL	FILE
VF Mon	Y , R, G, B, -G	Select signal to view in viewfinder.	2	Op.
VF Contour				
VF Contour	On , Off	Turn contours for viewfinder signal on or off.	2	Op.
Level	0..99 (50)	Set contour level for viewfinder signal.	2	Op.
Focus Assist	On, Off	Adds crawling effect in focused areas in the VF.		
Zebra		Zebra is a diagonal line pattern that warns you that the area affected has risen above a predetermined level of the full scale video exposure value.		
Zebra	On, Off	Turn zebra indication on or off.		
Zebra mode	Level , Band	Level: zebra indication appears in all overexposed picture areas. Band: zebra indication appears between two specified exposure levels.	3	Op.
Zebra level (%)	0..99 (90)	Set the exposure level where zebra indication is on.	3	Op.
Zebra contrast	0..99 (15)	Set the zebra indication contrast.	3	Op.
Centre Cross	On, Off	The Centre marker cross marks the centre of the picture.	0	Op.
Iris Ind. (SuperXpander)	On, Off	F stop number is displayed in VF	0	Op.
Focus Ind.	On, Off	Lens focus position indication: 0 = close-up, 99 = infinity	0	Op.
Zoom Ind.	On, Off	Zoom position indication, if supported by lens: 0 = wide, 99 = tele	0	Op.
Box Downright	Time, Battery, Tape, FLTR, Off	Select the type of information you want to see in the message box.	0	Op.

MENU	VALUES	DESCRIPTION	LEVEL	FILE
Safe area	On, Off	The safe area indicates an area that represents 80% of the whole viewfinder picture area.	0	Op.
Safe area type	16:9 , 15:9, 14:9, 4:3	Set the aspect ratio of the safe area marker.	0	Op.
Marker	On, Off	Turn on to show the used area limits.	0	Op.
Marker type	15:9, 14:9, 4:3	Set the aspect ratio of the used area marker.	0	Op.
Marker style	Dot , Shad, Both	Set the style of the used area marker.	0	Op.
Marker shading	Shad , Black	Set the shading of the used area marker.	0	Op.
Ind. White	0..99 (70)	Adjust the contrast of the characters.	2	Op.
Ind. Black	0..99 (30)	Adjust the black shading of the characters; 0 = black, 99 = no shading.	2	Op.
Display	On, Time (reset on power up)	Select the menu display to be on all the time or to disappear after a set time.	2	Op.
Menu Time	0..10 (10)	Set the length of time the menu is displayed when set to Time.	3	Op.
Info Time	0..20 (5)	Set the length of time that pop-up messages are displayed.	3	Op.
Rotary speed	0..10 (5)	Adjust the sensitivity of the rotary control wheel.	3	Op.
EXT AspectRatio	4:3 , 16:9	Aspect ratio converter for external video displayed in VF.	0	
LOC AspectRatio	4:3, 16:9	Aspect ratio when the SD 5-inch viewfinder is used (only with modification).	0	

6.2.2 Lens menu contents

MENU	VALUES	DESCRIPTION	LEVEL	FILE
Lens Type	STD , WA	Select a standard (STD) or wide angle (WA) type lens (affects white shading compensation).	0	Op.
Autolris	On , Off	Turns On / Off Auto Iris	0	
Peak/Average	0..99 (65)	Auto iris setting, balance between peak and average video level values.	3	Sc.
Auto Iris Setpoint	0..99 (35)	Auto Iris exposure level setting	3	Sc.
Mom. Iris Setpoint	0..99 (35)	Exposure setting in the central area. Exposed to 70% at setting = 50.	3	Sc.
Manufacturer	Ang, Fuj , Ang, Can, Other	Select the manufacturer of the lens (Angenieux, Canon, Fujinon or other) to compensate for differences in iris servo feedback.	0	
RE Iris comp.	On, Off	Turn on to compensate for iris loss when the lens Range Extender is turned on.	0	
Extended Iris		Automatically regulates the video level by adjusting the iris opening, the gain level and the exposure time to suit the ambient lighting conditions.		
Min Iris	F5.6, F8, F11, F16	Set the minimum iris value to be used with the extended iris function.	3	Op.
Max Iris	F1.4, F2.0 , F2.8, F4.0, F5.6	Set the maximum iris value to be used with the extended iris function.	3	Op.
Min Exp. Time	1/100..1/500	Set the minimum exposure time to be used with the extended iris function.	3	Op.
Max Gain (dB)	0..15 dB	Set the maximum gain value to be used with the extended iris function.	3	Op.
Autolris const				
Iris gain	5..10	Set sensitivity of auto iris: 5 = slow response, 10 = fast response	3	

6.2.3 Video menu contents

MENU	VALUES	DESCRIPTION	LEVEL	FILE
Colour Filter	0..99 (50)	This electronic colour filter varies the colour balance to obtain warmer or colder effects for the auto-white memory positions. It resets to 50 when the next automatic white balance process is carried out.	2	Sc.
Contour Level	0..99 (30)	Set contour enhancement level.	2	Sc.
Contour				
Level	0..99 (50)	Set contour enhancement level.	3	Sc.
Source select	Y, R, G, R+G	Select source to be used for contour generation: Y before knee, R, G, or average of R+G.	3	Sc.
vert cont	0..99 (50)	Adjust the level of vertical component in the contour signal.	3	Sc.
coarse/fine	0..99 (5)	Adjust the coarseness of the contours (0 is very fine).	3	Sc.
Soft Contour				
Soft Contour	Off, On	Set to On to reduce the amount of contour added for large transitions.	2	Sc.
Level	0..99 (70)	Adjust the upper limit level of contour enhancement for soft contours.	2	Sc.
Knee Contour	Off , 1, 2, 3, 4	Select a level of contour enhancement for the compressed signal above the knee (4 is high level of enhancement).	3	Sc.
Skin		Use skin contour to change the contour level within a selected colour range.		
Skin	Off , 1, 2, 1+2	Turns on skin contour and selects the memory position.	2	Sc.
Auto	Off , On	Select to take a sample of the skin colour.	2	-
View	Off , On	Set to on to indicate the selected area.	2	-
Skin Level	0..99 (15)	Decrease the skin contour level below 50 to soften the selected area. Increase the value above 50 to add extra contour.	2	Sc.
<more>				
width1 Red	0..99 (50)	Manual correction of skin gate (red saturation) for memory position 1. The higher the number, the broader the range.	3	Sc.
width1 Blue	0..99 (50)	Manual correction of skin gate (blue saturation) for memory position 1.	3	Sc.
color1 Red	0..99 (50)	Manual correction of skin gate (red color) for memory position 1.	3	Sc.
color1 Blue	0..99 (50)	Manual correction of skin gate (blue color) for memory position 1.	3	Sc.
width2 Red	0..99 (50)	Manual correction of skin gate (red saturation) for memory position 2.	3	Sc.
width2 Blue	0..99 (50)	Manual correction of skin gate (blue saturation) for memory position 2.	3	Sc.

MENU	VALUES	DESCRIPTION	LEVEL	FILE
color2 Red	0..99 (50)	Manual correction of skin gate (red color) for memory position 2.	3	Sc.
color2 Blue	0..99 (50)	Manual correction of skin gate (blue color) for memory position 2.	3	Sc.
Black				
Blackstretch	0..99 (99)	Set black stretch level (0 is no stretch).	3	Sc.
Master	0..99 (50)	Black level adjustment – RGB	2	Sc.
<more>			3	
Red	0..99 (50)	Black level adjustment – R	3	Sc.
Green	0..99 (50)	Black level adjustment – G	3	Sc.
Blue	0..99 (50)	Black level adjustment – B	3	Sc.
Master	0..99 (50)	Black level adjustment – RGB	3	Sc.
Gain				
Red	0..99 (50)	Manual red gain control	2	Sc.
Green	0..99 (50)	Manual green gain control	2	Sc.
Blue	0..99 (50)	Manual blue gain control	2	Sc.
Range	3dB , 6dB	Gain control step size	2	Op.
Knee	Off , Auto, Var	Knee Off, Auto, or variable (manual)	2	Sc.
Knee				-
Knee	Off , Auto, Var	Knee Off, Auto, or variable (manual)	3	Sc.
Knee Type	Y , NAM	Signal used for knee. (NAM: luminance of highest RGB component)	3	Sc.
Slope M	0..99 (60)	Adjusts the knee slope angle in manual mode	3	Sc.
Point M	0..99 (50)	Adjusts the knee slope point in manual mode	3	Sc.
Gamma	Nom , Low, Pre	Select Normal, Low (linearised on each selected curve) or Pre (manual curve).	2	Sc.
Gamma				
Gamma	Nom , Low, Pre	Select Normal, Low (linearised on each selected curve) or Pre (manual curve).	3	Sc.
Master	0..99 (76)	Adjust the RGB gamma curves manually.	3	Sc.
Red	0..99 (76)	Adjust the red gamma curve manually.	3	Sc.
Green	0..99 (76)	Adjust the green gamma curve manually.	3	Sc.
Blue	0..99 (76)	Adjust the blue gamma curve manually.	3	Sc.
Matrix	EBU, Skin , B/W, RAI, BBC, 1:1, CoolFL	EBU: True colour matrix. SKIN: Optimised for skin tone reproduction. B/W: Monochrome picture RAI: SONY cameras impression. BBC: BBC optimisation. 1:1: Matrix is off. COOLFL: Optimised for mixed fluorescent and incandescent lighting.	3	Sc.
Saturation	0..99 (50)	Adjust saturation	0	Sc.

6.2.4 Install menu contents

MENU	VALUES	DESCRIPTION	LEVEL	FILE
Video mode	Available modes (1080i59)	Select a video acquisition mode (Available modes depend on the camera version.)	3	-
HD Aspect Ratio	16:9 , Wide	Select the aspect ratio.	2	
IR receiver	Off , On	Enable or disable the remote control IR receiver on the camera.	0	Op.
Tally Hand grip (2")	On , Switch	Set to On so that the tally light at the rear of the hand grip follows the tally signal; set to Switch to allow it to be switched off with the switch on the 2" viewfinder.	0	
On-air Lamp (7")	Off, On	Set to On so that the tally light at the front of the 7" viewfinder follows the tally signal; set to Off if you never want it to light.	0	Op.
Intercom				
SideTone	0..99 (50)	Set the level of the sidetone in the camera operator's headphones.	1	Op.
Cam.Mic	Off, On, Switch	Set to Switch to allow the intercom routing switch on the adapter to route the intercom microphone signal.	1	Op.
Cam.Mic gain	0dB, 40dB	Set gain of camera operator's intercom microphone to 0dB or 40dB.	1	Op.
Cam.Mic power	Off , On	+48V phantom power to camera operator's intercom microphone.	1	Op.
Cam.Production	Off, Left, Right, Both	Select the camera operator's ear muff for the production intercom.	1	Op.
Cam.Engineering	Off, Left, Right, Both	Select the camera operator's ear muff for the engineering intercom.	1	Op.
Cam.Program	Off, Left, Right, Both	Select the camera operator's ear muff for the program audio.	1	Op.
Cam.Track	Off , Left, Right, Both	Select the camera operator's ear muff for the tracker intercom.	1	Op.
Cam.Track level	0..99 (50)	Set the level of the tracker signal in the camera operator's headphones	1	Op.
Track Mic to	Off , Cam, Eng, Prod, All	Select the tracker microphone routing.	1	Op.
Track Mic gain	0dB, 40dB	Set gain of tracker's microphone to 0dB or 40dB	1	Op.
Track Mic Power	On, Off	+48V phantom power to tracker's microphone	1	Op.
Track Source	Side , Eng	Select engineering intercom or tracker's microphone sidetone for tracker's headphone.	1	Op.
Cam. Mic to	CH1 , CH2		1	Op.
Audio			1	Op.
Audio1 Gain	-22dB, -28dB, -34dB, -40dB, -46dB, -52dB, -58dB, -64dB +6db, 0dB, -6dB, -12dB, -18dB, -24dB, -30dB, -34dB	Set gain of Audio 1 channel for mic. input. Set gain of Audio 1 channel for line input.	1	Op.
Audio1 HPF	On, Off	Turn Audio1 high-pass filter on to reduce 50Hz. hum or low frequency noise.		

MENU	VALUES	DESCRIPTION	LEVEL	FILE
Audio2 Gain	-22dB, -28dB, -34dB, -40dB, -46dB, -52dB, -58dB, -64dB +6db, 0dB, -6dB, -12dB, -18dB, -24dB, -30dB, -34dB	Set gain of Audio 2 channel for mic. input. Set gain of Audio 2 channel for line input.	1	Op.
Audio2 HPF	On, Off	Turn Audio 2 high-pass filter on to reduce 50Hz. hum or low frequency noise.	1	Op.
Notch	On, Off	Turn CVBS notch filter on or off.	3	Op.
Exposure				
Lighting	-10 ... +10 (0)	Select correction in 50 / 60Hz mode to synchronise with lighting frequency.	1	Sc.
Clean Scan				
Cl. Scan Mode	Normal, Extended	In normal mode the shutter blade is running (no smear). In extended mode shutter is not running (more accurate CLS but possible vertical smear).	1	
Value	50.6 ... 103.1Hz (50) 54.7 ... 121.5Hz (60)	Value depends on video mode.	1	Sc.
Units	Hz, msec	Select display units for clean scan.	1	
Gain preset				
gain -	-6dB, -3dB	Select gain value for - preset position.	2	Op.
gain +	+3dB, +6dB, +9dB	Select gain value for + preset position.	2	Op.
gain ++	+6dB, +9dB, +12dB	Select gain value for ++ preset position.	2	Op.
Timing				
H.Phase	0..99 (50)	Adjust CVBS H-phase.	0	Op.
V-shift	Off, On	Set to On to synchronize camera with DLP projectors or to hide the horizontal bar of CRT monitors. (Only available for a limited number of video modes.)	0	
V-shift level	0..99	Variable video delay from 0 to 1 frame.	0	
Quick Smart Touch	On, Off	When On, green STD button opens Smart Touch menu (if installed).	1	
Private Data	Off, C->B, B->C, B<->C	Select the purpose of the tracker intercom channel: tracker microphone (Off), or private data between camera (C) and base station (B).	0	
Fan operation				
Head fan	On, Off	Turns the head fan off. Turns itself on after 2 hours or if it gets too hot.	3	
Adapter fan	On, Off	Turns the adapter fan off. Turns itself on after 2 hours or if it gets too hot.	3	
VTR lens	Inter, Zoom, EXT 1, EXT 2	Select the function of the VTR switch on the lens.	1	
VTR camera	Inter, Zoom, EXT 1, EXT 2	Select the function of the VTR switch on the camera.	1	
Zoom switch	Mom., Alt.	Select how the zoom switch operates: momentary or alternating (latched).	1	

6.2.5 Files menu contents

MENU	VALUES	DESCRIPTION	LEVEL	FILE
Store Scene file			2	
file select	SCAM 1..4, SCARD 1..4,	Select a memory-stored file (SCAM) or a card-stored file (SCARD).	2	
store	Exec	Select to store the current settings in the selected file.	2	
Recall Scene file			1	
file select	<available files>	Select a file.	1	
recall	Exec	Select to overwrite the current settings with the settings in the selected file.	1	
Store Operator file			1	
file select	OCAM 1, OCARD 1..2	Select a file.	1	
store	Exec	Select to store the current settings in the selected file.	1	
Recall Operator file			1	
file select	<available files>	Select a file.	1	
recall	Exec	Select to overwrite the current settings with the settings in the selected file.	1	
Attributes				
file select	<available files>	Select a file.	2	
file name	<file name>	Displays the file's name	2	
attribute	R, R/W	R: read only; R/W: read and write	2	
Standard Files		Smart-Touch optional software		
Standard Settings	Exec	Recalls camera standard settings		
Lighting				
Night	Exec	Enhances visibility of dark scenes.	2	
Fluorescent	Exec	Reduces green tinge.	2	
Extreme contrast	Exec	Handling of highlights and details in dark scenes simultaneously.	2	
Creative				
Sport Warm Color	Exec	Rich contrast to bring up team colours.	2	
Sport Interview	Exec	Dual skin tone control	2	
Hi Film	Exec	High contrast film-like look.	2	
Hi Film + Skin	Exec	High contrast film-like look + dual skin tone control for close-ups.	2	
Lo Film	Exec	Low contrast film-like look for studio production.	2	
Lo Film + Skin	Exec	Low contrast film-like look + dual skin tone control for close-ups.	2	
Sepia Film	Exec	Sepia tone look.	2	
Matching		Files for camera matching.		
LDK9x + LDK10	Exec	For older Philips cameras.	2	

MENU	VALUES	DESCRIPTION	LEVEL	FILE
DVW-xxx	Exec	For Sony camcorders.	2	
HL-xxx	Exec	For Ikegami camcorders.	2	
Standard Settings	Exec	Recalls camera standard settings.	2	

6.2.6 Security menu contents

MENU	VALUES	DESCRIPTION	LEVEL	FILE
Installed Level	user0.. user3	Select the user level.	2	
Run Hours			2	
days ago	<days>	Checks operation time for the set number of days.	2	
set time		Set the time.	2	
Hour	00..23	Set the value for Hours	2	
Minute	00..59	Set the value for Minutes	2	
set date		Set the date.	2	
Year	1900..2100	Set the value for Year	2	
Month	1..12	Set the value for Month	2	
Day	1..31	Set the value for Day	2	
PIN Code	**** (0000)	Set four-digit PIN code (no confirmation!).	0	
Station Name	<name>	Displays the station name	0	
Customer Files			0	
Store Cust. Scene	Exec	Select to store the current settings in the customer scene file.	0	
Store Cust. Oper	Exec	Select to store the current settings in the customer operator file.	0	
Green Button			0	
Standard	Fact, Cust	Select factory or customer file for green button recall.	0	
Scene file	On, Off	Select if the file is to be recalled when the green button is pressed.	0	
Operator file	On , Off	Select if the file is to be recalled when the green button is pressed.	0	

6.2.7 Diagnostics menu contents

MENU	VALUES	DESCRIPTION	LEVEL	FILE
Adaptor Type	Triax, DVCPRO, ...	Displays value	2	
Sensor Type	IT, ITW, FT, DPM	Displays value	2	
Sensor Voltage	Ok, NotOK	Displays value	2	
Shutter Run	Run, Stop	Displays value	2	
Front Power	Ok, NotOk	Displays value	2	
Camera 12nc	last 4 digits of type no.	Displays value	2	
Camera Status	2 digits	Displays value	2	
Adapter 12nc	last 4 digits of type no.	Displays value	2	
Adapter Status	2 digits	Displays value	2	
PPG Status	0..255	Displays value	0	
DVP Status	0..255	Displays value	0	
Cam. temp	<temp>	Displays value	0	
Head temp C	-55..128	Displays value	0	
Head temp F	-67.262	Displays value	0	
Head fan	Off, Low, Mid, High, Max	Displays value	0	
Adaptor temp C	-55..128	Displays value	0	
Adaptor temp F	-67.262	Displays value	0	
Adaptor fan	Off, Low, Mid, High, Max	Displays value	0	

6.3 Where to find a function

The following table contains an alphabetical list of the functions and points to their location in the menu structure.

	Function	Subfunction	Menu path
A			
	Aspect Ratio		
		select	INSTALL \ HD ASPECT RATIO
		external (VF signal)	VIEWFINDER \ EXT ASPECT RATIO
		local (5"VF)	VIEWFINDER \ LOC ASPECT RATIO
	Audio		
		gain	INSTALL \ AUDIO
		HP filter	INSTALL \ AUDIO
	Auto Iris		
		switch	LENS
		peak/average	LENS
		setpoint	LENS
		iris gain	LENS \ AUTOIRIS CONST
B			
	Black		
		black stretch	VIDEO \ BLACK
		dynamic black	VIDEO \ BLACK
		level Blue	VIDEO \ BLACK \ MORE
		level Green	VIDEO \ BLACK \ MORE
		level Red	VIDEO \ BLACK \ MORE
		master level	VIDEO \ BLACK
C			
	Camera	matching	FILES \ STANDARD FILES \ MATCHING
	Clean scan		

	Function	Subfunction	Menu path
		mode	INSTALL \ EXPOSURE \ CL. SCAN
		units	INSTALL \ EXPOSURE \ CL. SCAN
		value	INSTALL \ EXPOSURE \ CL. SCAN
	Colour	filter	VIDEO \
	Contour		
		coarse/fine level	VIDEO \ CONTOUR \ MORE
		level	VIDEO \ CONTOUR
		source select	VIDEO \ CONTOUR
		vertical contour level	VIDEO \ CONTOUR \ MORE
	Creative settings		FILES \ STANDARD FILES
	Customer Standard file		
		store Operator file	SECURITY \ CUSTOMER FILES
		store Scene file	SECURITY \ CUSTOMER FILES

D

	Disable Camera		INSTALL
--	----------------	--	---------

E

	Exposure time	lighting	INSTALL \ EXPOSURE
	Extended Iris parameters		LENS \ EXTENDED IRIS

F

	Fan operation		
		head	INSTALL \ FAN OPERATION
		adapter	INSTALL \ FAN OPERATION
	File Attributes		FILES
	Focus assist	switch	VF

G

	Gain		
		level blue	VIDEO \ GAIN

Function	Subfunction	Menu path
	level green	VIDEO \ GAIN
	level range	VIDEO \ GAIN
	level red	VIDEO \ GAIN
	presets	INSTALL \ GAIN PRESET
Gamma	select	VIDEO
	select	VIDEO \ GAMMA
	level blue	VIDEO \ GAMMA
	level green	VIDEO \ GAMMA
	level master	VIDEO \ GAMMA
	level red	VIDEO \ GAMMA
Green Button	file recall	SECURITY \ GREEN BUTTON

I

Installed User Level		SECURITY
Intercom		
	cameraman	INSTALL \ INTERCOM
	tracker	INSTALL \ INTERCOM
IR receiver switch		INSTALL

K

Knee		
	contour switch	VIDEO \ KNEE CONTOUR
	master point	VIDEO \ KNEE
	master slope	VIDEO \ KNEE
	switch	VIDEO
	type	VIDEO \ KNEE

L

Lens		
	RE iris compensation	LENS

	Function	Subfunction	Menu path
		manufacturer	LENS
		type	LENS
	Lighting conditions		FILES \ STANDARD FILES

M

	Marker		
		shading	VF
		style	VF
		switch	VF
		type	VF
	Matrix	select	VIDEO
	Momentary iris	setpoint	LENS

N

	Notch		INSTALL
--	-------	--	---------

O

	On-air lamp	switch	INSTALL
	Operator file		
		recall	FILES \ RECALL OPER. FILE
		store	FILES \ OPER. FILE

P

	PIN code		SECURITY
	Private data		INSTALL

Q

	Quick Smart Touch		INSTALL \ QUICK SMART TOUCH
--	-------------------	--	-----------------------------

R

	Recall Scene file		FILES
	Recall Oper. file		FILES
	Run Hours settings		SECURITY

	Function	Subfunction	Menu path
	Rotary speed		VF

S

	Saturation		VIDEO
	Scene file recall switch		FILES \ RECALL SCENEFILE
	Scene file store switch		FILES \ STORE SCENEFILE
	Skin Contour		
		auto	VIDEO \ SKIN
		level	VIDEO \ SKIN
		paramaters (width, color)	VIDEO \ SKIN \ MORE
		select	VIDEO \ SKIN
		view	VIDEO \ SKIN
	Soft Contour		
		level	VIDEO \ SOFT CONTOUR
		switch	VIDEO \ SOFT CONTOUR
	Standard files		FILES
	Standard Settings		FILES \ STANDARD FILES
	Store Scene file		FILES
	Store oper. file		FILES

T

	Tally Light switch		INSTALL
	Timing		
		H. phase	INSTALL \ TIMING
		V-shift	INSTALL \ TIMING
		V-shift level	INSTALL \ TIMING

U

	User level select		SECURITY \ INSTALLED LEVEL
--	-------------------	--	----------------------------

V

	Function	Subfunction	Menu path
	VF		
		Audio Bar switch	VF
		Contour level	VF \ VF CONTOUR
		Contour switch	VF \ VF CONTOUR
		Centre cross switch	VF
		Focus ind. switch	VF
		Iris indicator switch	VF
		Info time	VF
		Menu time	VF
		Rotary speed	VF
		Safe area switch	VF
		Text display time	VF
		Zebra parameters	VF \ ZEBRA
		Zoom ind. switch	VF
	Video mode		INSTALL

Z

	Zebra		
		Contrast	VF \ ZEBRA
		level	VF \ ZEBRA
		mode	VF \ ZEBRA
		switch	VF \ ZEBRA
	Zoom	indicator	VF

Chapter 7

Connectors

7.1 Camera connectors

Figure 7-1. Camera connector location

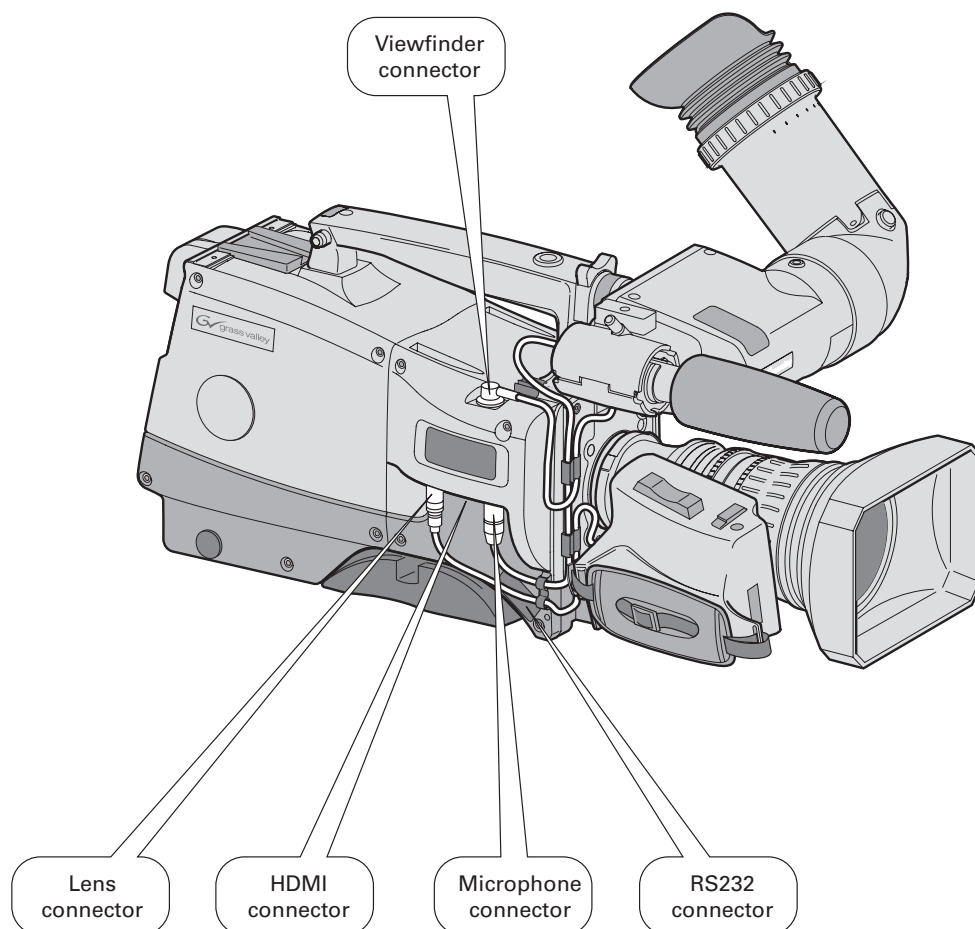

7.1.1 Viewfinder connector

Figure 7-1. Camera viewfinder connector

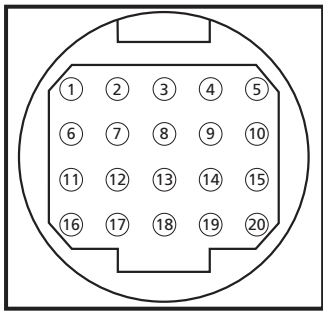

20-pole female; panel view
 Panel part number (X14): 5322 214 12544
 Cable part number (male): 5322 320 12159

- | | |
|----------------------|---------------|
| 1. -80V | 11. GND |
| 2. n.c. | 12. vf video |
| 3. GND | 13. Pb vf ret |
| 4. INTN-D | 14. Pr vf ret |
| 5. vf ext video | 15. GND |
| 6. n.c. | 16. +batt |
| 7. vf video ret | 17. +batt |
| 8. SDA-D | 18. Pb vf |
| 9. SCL-D | 19. Pr vf |
| 10. vf ext video ret | 20. shield |

7.1.2 HDMI connector

Figure 7-2. HDMI - VF connector

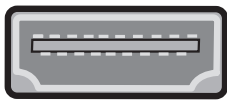

HDMI type A (19-pole)

- | | |
|-----------------------|-----------------------|
| 1. TDMS Data 2+ | 11. TDMS Clock shield |
| 2. TDMS Data 2 Shield | 12. TDMS clock - |
| 3. TDMS Data 2 - | 13. VF-video (CEC) |
| 4. TDMS Data 1+ | 14. + 12 V (switched) |
| 5. TDMS Data 1 Shield | 15. SCL |
| 6. TDMS Data 1- | 16. SDA |
| 7. TDMS Data 0+ | 17. Ground |
| 8. TDMS Data 0 shield | 18. +5V power |
| 9. TDMS Data 0- | 19. Hot Plug Detect |
| 10. TDMS Clock+ | |

7.1.3 Lens connector

Figure 7-3. Camera lens connector

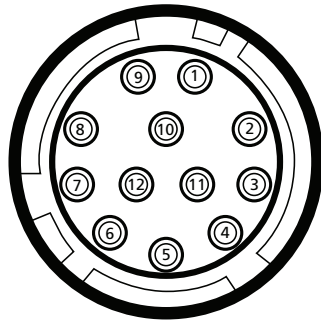

- | | |
|-----------------------|------------------------|
| 1. Ext. Video On/Off | 8. Lens Servo |
| 2. VTR Trigger Switch | 9. Range Extender |
| 3. -batt | 10. Zoom Follow |
| 4. Momentary Iris | 11. Focus follow* |
| 5. IrisControl | 12. Spare |
| 6. + batt | |
| 7. Iris Follow | * not standard on lens |

Hirose 12-pole female; panel view
 Panel part number (X15): 5322 265 10389
 Cable part number (male): 5322 265 41208

7.1.4 Audio microphone connector

Figure 7-4. Audio microphone connector

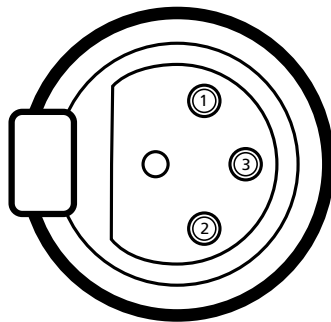

1. Audio Screen
2. Audio In
3. Audio Return

Microphone impedance >200 ohm

Sensitivity range: -70 to -28 dBm

Signal at pin 2 of audio input is in phase with signal at pin 2 of audio output.

XLR 3-pole female; panel view
 Panel part number (X13): 5322 267 40523

7.1.5 RS232 serial connector

Figure 7-5. RS232 serial connector

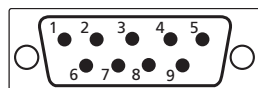

SubD 9-pin male; panel view (X12)

- | | |
|------------|-----------|
| 1. SPARE | 6. RS-DSR |
| 2. RS-RXD | 7. RS-RTS |
| 3. RS-TXD | 8. RS-CTS |
| 4. RS-DTR | 9. +12V |
| 5. RS-DGND | |

7.2 Connectors on the TriaxHD adapter

Figure 7-2. TriaxHD adapter connector location

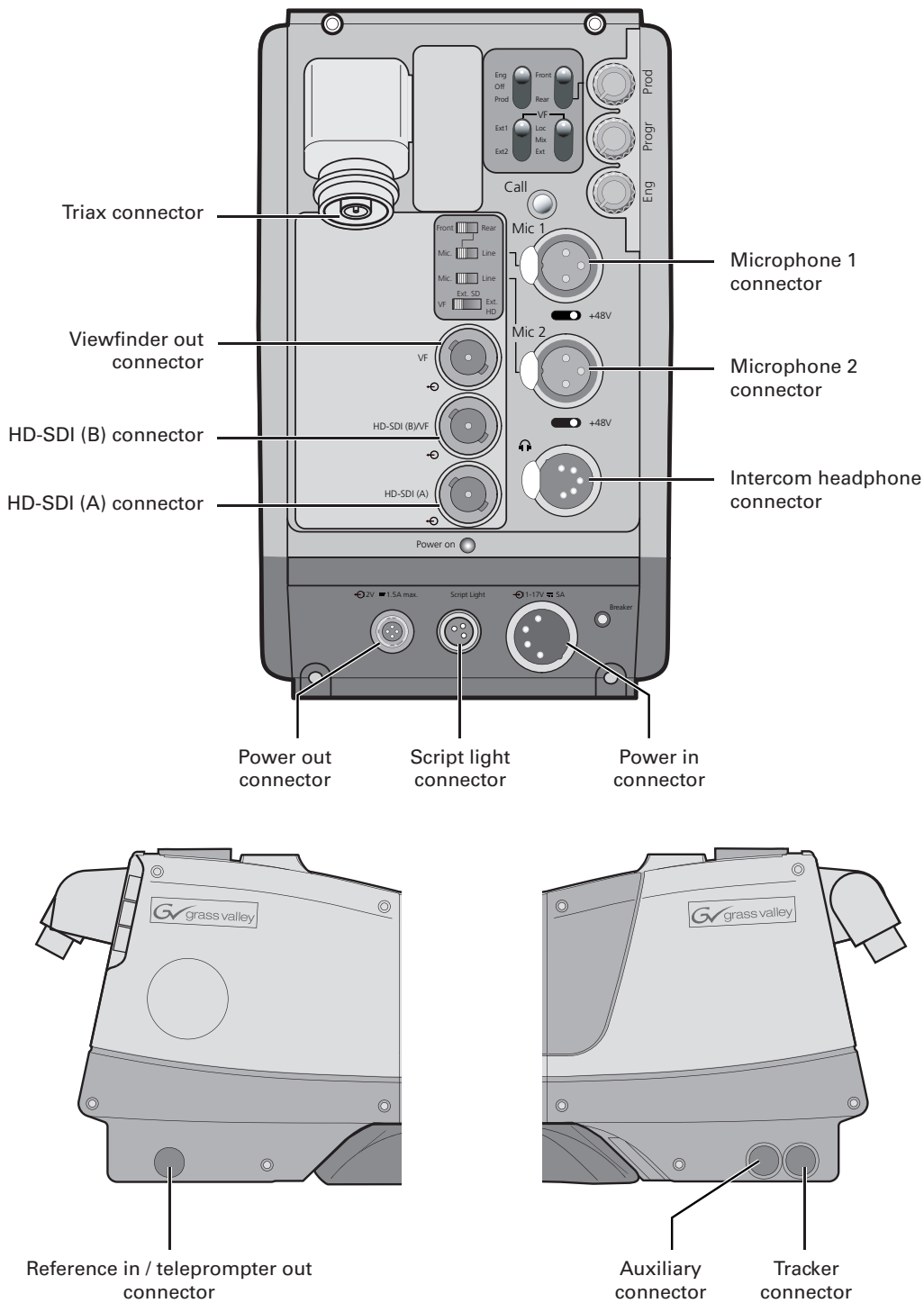

7.2.1 Triax connector

Figure 7-6. Triax connector

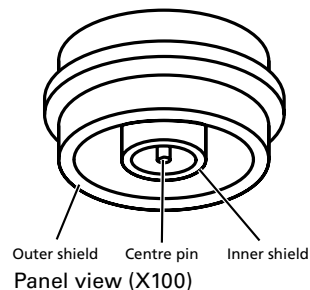

1. Centre pin: Power and signals
2. Inner shield: Return
3. Outer shield: Camera housing GND

Various types of triax connector are available.

7.2.2 Viewfinder / External video output connector

Figure 7-7. Analogue video output connector

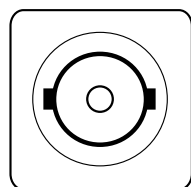

BNC connector: panel view (X107)

This socket provides an analogue 1.0 Vpp output viewfinder signal or an external video signal from the Base Station.

A switch selects either the VF signal (Y-only), an SD external signal (CVBS) or a scaled HD external signal (Y-only).

7.2.3 HD - SDI (B) connector

Figure 7-8. HD - SDI (B) connector

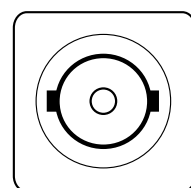

BNC connector: panel view (X106)

This socket provides the HD-SDI output viewfinder signal or the external video signal from the Base Station.

1080p50/60 mode

This socket is used as part of the dual link connection to carry a 4:2:2 signal stream according to SMPTE 372M.

7.2.4 HD - SDI (A) connector

Figure 7-9. HD - SDI (A) connector

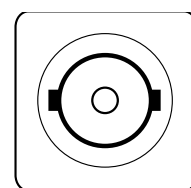

BNC connector: panel view (X105)

This socket is used to output the camera HD-SDI video signal according to SMPTE 292M.

1080p50/60 mode

This socket is used as part of the dual link connection to carry a 4:2:2 signal stream according to SMPTE 372M.

7.2.5 Audio microphone 1 connector

Figure 7-10. Audio microphone 1 connector

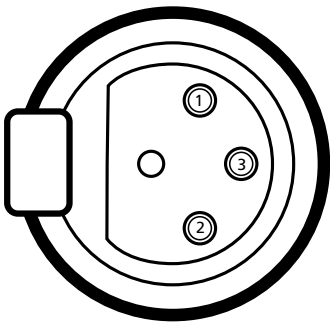

XLR 3-pole female; panel view (X102)

1. Audio Screen
2. Audio In
3. Audio Return

Microphone impedance > 200 ohm
Phantom power +48V switchable
Sensitivity range microphone: -64 to -22 dBu

Sensitivity range line: +10 to +42 dBu

Signal at pin 2 of audio input is in phase with signal at pin 2 of audio output.

7.2.6 Audio microphone 2 connector

Figure 7-11. Audio microphone 2 connector

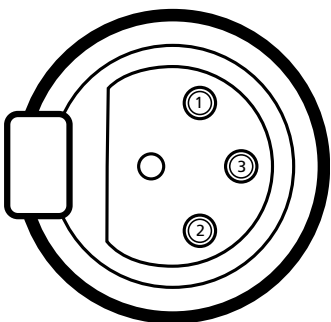

XLR 3-pole female; panel view (X103)

1. Audio Screen
2. Audio In
3. Audio Return

Microphone impedance >200 ohm
Phantom power +48V switchable
Sensitivity range microphone: -64 to -22 dBu

Sensitivity range line: +10 to +42 dBu

Signal at pin 2 of audio input is in phase with signal at pin 2 of audio output.

7.2.7 Intercom headset connector

Figure 7-12. XLR intercom headset connector

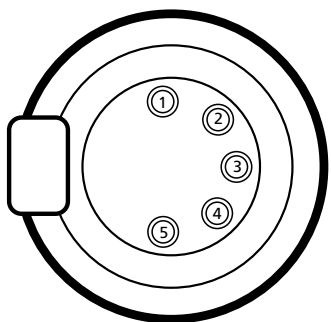

XLR 5-pole female; panel view (X104)

1. Microphone return
2. Microphone
3. Telephone return
4. Telephone left
5. Telephone right

Microphone level: -64 dBu / -24 dBu switchable
Microphone impedance: >600 Ohm

Output level: +6 dBu nominal
Output impedance: <50 Ohm

7.2.8 DC power input socket



Caution

The input voltage must not exceed +17 Vdc.

Figure 7-13. DC power input connector

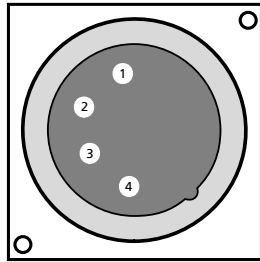

XLR 4-pin male: panel view (X101)

1. Ground
2. Ground (internally bridged to pin 1)
3. +11.5 Vdc . . . +17 Vdc (internally bridged to pin 4)
4. +11.5 Vdc . . . +17 Vdc

This socket accepts a DC voltage of 15V nominal.

7.2.9 DC power and tally output socket

Figure 7-14. DC power and tally output connector

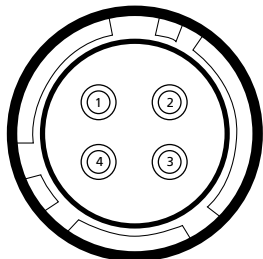

Hirose 4-pole female: panel view

1. Ground
2. On air
3. No connection
4. +12 Vdc (max. 18W)

Shield of cable directly to the connector housing.

The socket provides access to an internal tally switch. When the camera is on-air, the contact of the internal relay is closed.

7.2.10 Script light power supply socket

Figure 7-15. Script light power supply output connector

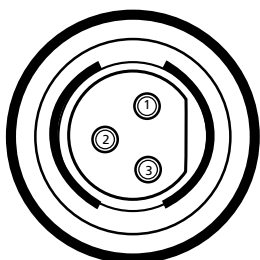

Fischer 3-pole female: panel view (X111)

1. +12 Vdc (maximum dissipation 3W)
2. Power return
3. Shield

7.2.11 Teleprompter output / Reference input connector

Figure 7-16. Teleprompter / Reference connector

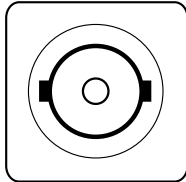

BNC connector: panel view (X112)

Teleprompter - Triax mode

This socket supplies the 1Vpp teleprompter signal applied to the Base Station.

Reference Input - Local mode

This connector is used to genlock the camera to a 0.6 Vpp HD tri-level reference input signal.

7.2.12 Tracker communications connector

Figure 7-17. Tracker communications connector

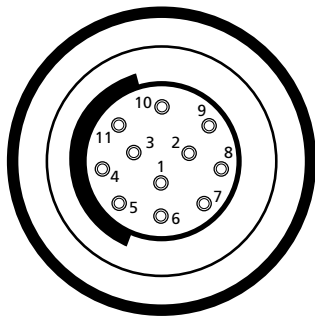

Fischer 11-pole female; panel view

Panel part number (X108): 3922 040 02463

1. On-air signal return
2. Tracker microphone return
3. Tracker microphone input
4. Production tracker
5. Sidetone/engineering tracker
6. Intercom return
7. Program sound tracker
8. Cameraman microphone
9. Tally control tracker (Cmos level, R out = 1k)
10. +12V; I max. = 100mA
11. +12V return

Microphone level: -64dBu/-24dBu switchable
Microphone impedance: >600 ohm

Intercom output level: nom. 0 dBu , max +6 dBu
Intercom output impedance: <200 ohm

7.2.13 Auxiliary connector

Figure 7-18. Auxiliary connector

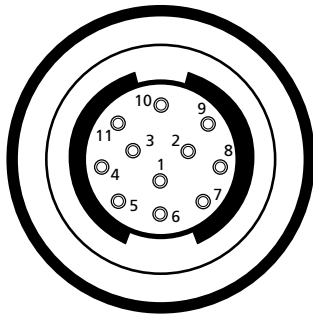

Fischer 11-pole female; panel view

Panel part number (X109): 3922 040 02512

1. +5VL
2. 0VL
3. AN0
4. AN1
5. Spare
6. On-air n.c.
7. Private Data Camera to Base Station
8. Ground
9. Private Data Base Station to Camera
10. Ground
11. Shield

Private data input signals:

0 < 0.8 Volt; 1 > 2.4 Volt

max. level: +/- 12 Volt

input impedance: > 100 kOhm

baud rate: 2400 bits/s nom; 4800 bits/s max.

Private data output signals:

C-MOS levels 5V

output impedance: < 1 kOhm.

Analogue outputs (AN0 and AN1):

output level: 0 - 5 Volt

output impedance: 100 Ohm

Chapter 8

Specifications

8.1 Specifications for LDK 4000 MKII

Item	Value
Power requirements	supplied via adapter or local power
Power consumption	60 W (camera head + TriaxHD adapter + viewfinder)
Operating temperatures	-20 to +45°C (-4 to +113°F)
Storage temperatures	-20 to +60°C (-4 to +140°F)
Weight (approx.)	5.0 kg (11.0 lbs) incl. 2-inch VF and TriaxHD adapter
Pick-up device	3 x 2/3-inch HD-DPM ⁺ CCDs 1080i or 720p (non-switchable)
Picture elements	9.2 million pixels 1920 (H) x 4320 (V) effective
Digital quantization	14-bit A to D
Digital signal processing	74.25 MHz or 148.5 MHz, better than 22-bit accuracy
Sensitivity	2000 lux (186 ft cd) at F8.0 (typical, 1080i50 mode), reflectance 90%
Minimum illumination	Approx. 12 lux at F 1.4 and +12 dB gain
Exposure control	Down to 1/1000
Clean scanning	50.6 to 125 Hz (at 50 Hz) 61 to 150 Hz (at 59.94 Hz.)
Smear	no vertical smear
Optical system	F1.4 prism system
Optical filters	Clear, 1/4 ND, 1/16 ND, 1/64 ND clear, 4-point star, 6-point star, soft focus
Modulation depth	55% at 27 MHz (typical, 720p mode)
S/N ratio	56 dB in Y (typical)
Registration	<25 ns (0.05% max.) in all zones, without lens
Dynamic range	>400%
Gain	-6dB to +15dB in 3dB steps or continuously variable
Colour matrices	6 standard, 2 variable
Colour temperature	4 standard, 2 memories and continuously variable

Item	Value
White balance range	2500 - 20000 K
Highlight compression	Pivoting knee; Digital True Colour Knee
Digital contrast	Black stretch and black press
Contour enhancement	Full amplitude RGB, extended dynamic range circuit
Skin tone memories	2
Viewfinder option types	(Model LDK 5302 2-inch) resolution >600 TV lines (centre) (Model LDK 5305 5-inch) resolution >650 TV lines (centre) (Model LDK 4020 7-inch) resolution >800 TV lines (centre)

8.2 Specifications for LDK 5860 TriaxHD adapter

Item	Value
Power requirements	Triax powered or 12 Vdc
Operating temperatures	-20 to +45°C (-4 to +113°F)
Storage temperatures	-20 to +60°C (-4 to +140°F)
Weight (approx.)	2.3 kg
Dimensions	220 (L) x 120 (W) x 205 (H) without handgrip
Triax in/out	Swivel connector; Fischer, ARD, Lemo or Trilock
Triax cable length	1,200m (4,000ft.) max. with 14mm cable
Video out	2x HD-SDI (SMPTE 292M)
Monitor	Analogue 1 Vpp; 75 Ohm; BNC
Teleprompter out or Reference in (local mode)	1 Vpp; 75 Ohm; BNC 0.6 Vpp HD tri-level reference signal
Tracker	11 pins Communication / Signalling
Auxiliary/ Data	11 pins private data
Rear microphone in (2x)	XLR 3, balanced, +48V
Intercom	XLR5 with channels ENG/PROD/PROG
Power input	12Vdc, XLR-4 male
Scriptlight power output	12Vdc, 0.25A, 3-pin Fischer
Power output	12Vdc, 1.5A, 4-pin Hirose 1.5 Amp.

8.2.1 Dimensions

Figure 8-1. Dimensions

