

# LDK 4628/O5

## Operational Control Panel

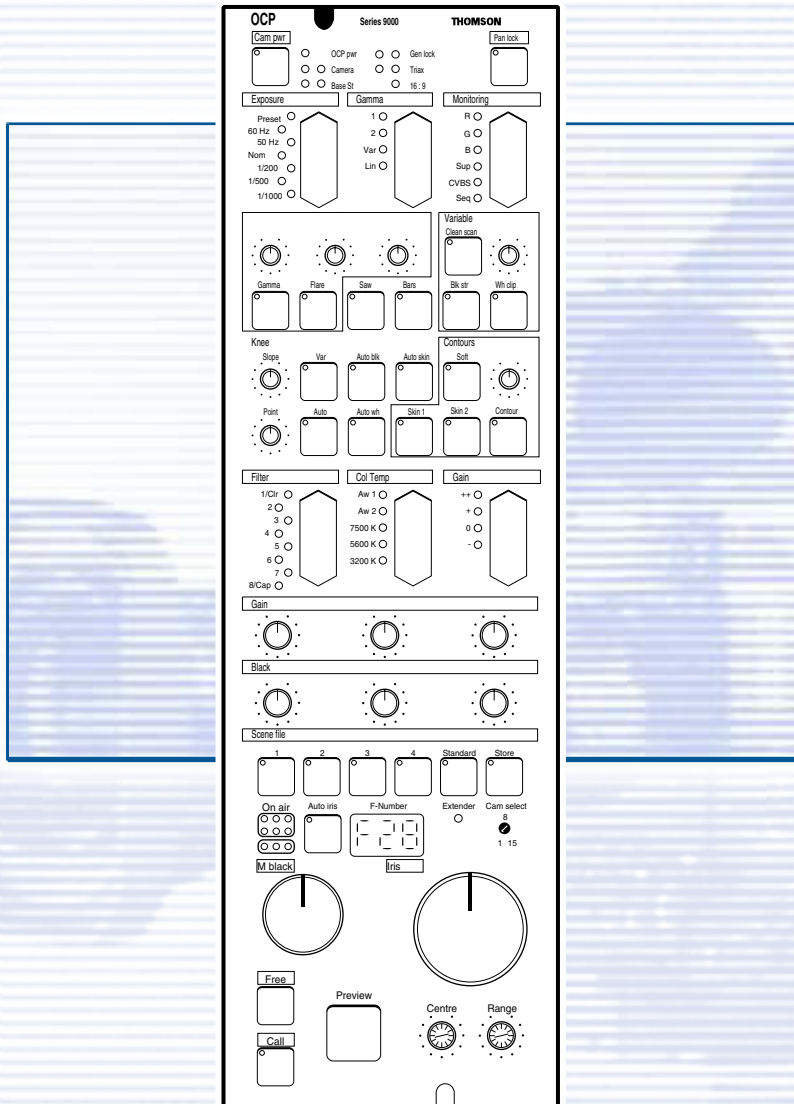

# Technical Manual



3922 496 48351 St.00

## Declaration of Conformity

---

We, Thomson Broadcast Solutions Nederland B.V., Kapittelweg 10, 4827 HG Breda, The Netherlands declare under our sole responsibility that this product is in compliance with the following standards:

- EN60065 : Safety
- EN55103-1 : EMC (Emission)
- EN55103-2 : EMC (Immunity)

following the provisions of:

- a. the Safety Directives 73/23/EEC and 93/68/EEC
- b. the EMC Directives 89/336/EEC and 93/68/EEC

## FCC Class A Statement

---

This product generates, uses, and can radiate radio frequency energy and if not installed and used in accordance with the instructions, may cause interference to radio communications.

It has been tested and found to comply with the limits for a class A computing device pursuant to Subpart J of part 15 of FCC rules, which are designed to provide reasonable protection against such interference when operated in a commercial environment.

Operation of this product in a residential area is likely to cause interference in which case the user at his own expense will be required to take whatever measures may be required to correct the interference.

## Copyright

---

Für diese Unterlage behalten wir uns alle Rechte vor (Gemäß DIN 34). Technische Änderungen im Zuge der Weiterentwicklung vorbehalten.

Copying of this document and giving it to others, and the use or communication of the contents thereof, are forbidden without express authority. Offenders are liable to the payment of damages. All rights are reserved in the event of the grant of a patent or the registration of a utility model or design. Liable to technical alterations in the course of further development.

Toute communication ou reproduction de ce document, toute exploitation ou communication de son contenu sont interdites, sauf autorisation expresse. Tout manquement à cette règle est illicite et expose son auteur au versement de dommages et intérêts. Tous nos droits sont réservés pour le cas de la délivrance d'un modèle d'utilité. Sous réserve de modification au cours de l'évolution technique.

---

**LDK 4628/05**  
**Operational Control Panel**  
**Technical Manual**

---

**Contents**

---

Safety Summary .....	2	Internally Selectable Functions .....	10
Cautions and Warnings .....	2	Replacing the fuses .....	11
Earthing .....	3	Interconnections .....	12
Packing/Unpacking .....	4	Two-wire Data Control Bus .....	14
Opening the Operational Control Panel .....	5	Connectors and Cables .....	15
Mounting in a Desk .....	6	Dimensions .....	17
Mounting in a 19 inch Rack .....	8		

This information is intended as a guide for trained and qualified personnel who are aware of the dangers involved in handling potentially hazardous electrical/electronic equipment. It is not intended to contain a complete list of all safety precautions which should be observed by personnel in using this or other electronic equipment.

The installation, maintenance and service of this equipment involves risks both to personnel and equipment and must be performed only by qualified personnel exercising due care.

Personnel engaged in the installation, operation, maintenance or servicing of this equipment are urged to become familiar with First Aid theory and practices.

During installation and operation of this equipment, local building safety and fire protection standards must be observed.

Before connecting the equipment to the power supply of the installation, the proper functioning of the protective earth lead of the installation needs to be verified.

Whenever it is likely that safe operation is impaired, the apparatus must be made inoperative and secured against any unintended operation. The appropriate servicing authority must then be informed. For example, safety is likely to be impaired if the apparatus fails to perform the intended function or shows visible damage.

This product has been designed and tested according to EN60065.

When performing service, be sure to read and comply with the warning and caution notices appearing in the manuals. Warnings indicate danger that requires correct procedures or practices to prevent death or injury to personnel. Cautions indicate procedures or practices that should be followed to prevent damage or destruction to equipment or property.

### WARNING

THE CURRENT AND VOLTAGES PRESENT IN THIS EQUIPMENT ARE DANGEROUS. ALL PERSONNEL MUST AT ALL TIMES FOLLOW THE SAFETY REGULATIONS.

ALWAYS DISCONNECT POWER BEFORE REMOVING COVERS OR PANELS.

ALWAYS DISCHARGE HIGH VOLTAGE POINTS BEFORE SERVICING.

NEVER MAKE INTERNAL ADJUSTMENTS, PERFORM MAINTENANCE OR SERVICE WHEN ALONE OR WHEN FATIGUED.

IN CASE OF AN EMERGENCY ENSURE THAT THE POWER IS DISCONNECTED.

ANY INTERRUPTION OF THE PROTECTION CONDUCTOR INSIDE OR OUTSIDE THE APPARATUS, OR DISCONNECTION OF THE PROTECTIVE EARTH TERMINAL, IS LIKELY TO MAKE THE APPARATUS DANGEROUS. INTENTIONAL INTERRUPTION IS PROHIBITED.

FOR SAFETY REASONS THE CPU MUST BE MOUNTED IN A 19-inch RACK WHICH HAS SAFETY COVERS ACCORDING TO IEC65.

WHEN TWO CPUs ARE MOUNTED ABOVE EACH OTHER THE MINIMUM DISTANCE BETWEEN THEM MUST BE 50MM OR THE RACK MUST BE FORCE-AIR COOLED.

USE ONLY FUSES OF THE TYPE AND RATING SPECIFIED.

### CAUTION

To prevent risk of overheating, ventilate the product correctly.

Connect the product only to a power source with the specified voltage rating.





Only connect a Triax cable from the LDK 6 camera family to an LDK 6 CPU. Never connect it to any other base station.

Never connect the Triax cable from a camera to a CPU of a different family; never connect the LDK family to the TTV family.

Do not allow system ground currents to exceed 1.5A in the outer shield of the triax cable or 0.2A in other cable shields.

It is strictly prohibited to short circuit the inner and outer shields of a triax cable used to connect a camera to a base station.

# Earthing

Symbol	Colour	Explanation
	Red	High voltage terminal at which a voltage, with respect to an other terminal, exists or may be adjusted to 1000V or more.
	Yellow/Black	Live part.
	Yellow/Black	This marking indicates that the operator must refer to an explanation in the Instruction Manual, or that a specific component must be replaced by the component specified in the documentation for safety reasons.
	White/Black	Protective earth (ground) terminal.



### Cathode ray tubes

Components marked  on the circuit diagram are critical for safety and include those specified to comply with X-ray emission standards for units using cathode ray tubes and those specified for compliance with various regulations regarding spurious radiation emission.

When servicing units that use cathode ray tubes (CRTs), the cathode ray tubes themselves, the high voltage circuits and related circuits are specifically chosen so that they comply with recognized codes pertaining to X-ray emission.

Consequently, when servicing, replace the cathode ray tubes and other parts with specified parts only. Do not attempt to modify these circuits as any unauthorized modification can increase the high voltage value and cause X-ray emission from the cathode ray tube.

Handle the cathode ray tube only when wearing shatterproof goggles and after discharging the high voltage completely.

The rear of a CPU has two separate screw terminals for protective earth  (PE) and video earth  (VE).

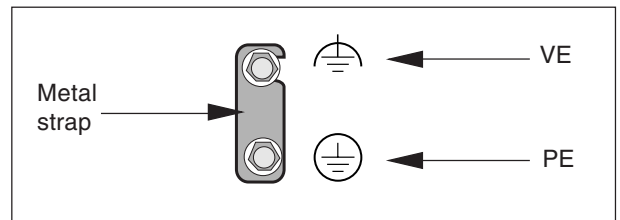

These are normally connected by a metal strap. The protective earth terminal is internally connected to the protective earth conductor of the power cable. If required, the central earth connection wire of the studio can be connected to terminal PE.

In normal circumstances the connection between the protective earth and the video earth should not be broken.

The metal strap may be removed only if the studio (or OB van) is equipped with separate protective and video earth systems. Under these circumstances the video earth terminal must be connected to the central functional earth potential (video earth) of the studio. This earth potential should have functional protective and noiseless earth (FPE) qualities as stated in the VDE regulation 0800/part2. A low impedance interconnection of both earth conductors must be provided at the central studio earthing point.

### WARNING

THE UNIT MUST ALWAYS BE CONNECTED TO PROTECTIVE EARTH.

### Mains Lead Wiring for UK Users

The wires in the mains lead are coloured in accordance with the following code:

GREEN AND YELLOW	-	EARTH
BLUE	-	NEUTRAL
BROWN	-	LIVE

As the colours of the wires in the mains lead of this apparatus may not correspond with the coloured markings identifying the terminals in your plug proceed as follows:

- The wire coloured GREEN AND YELLOW must be connected to the terminal on the plug marked with the letter E or by the safety earth symbol  or coloured GREEN or GREEN AND YELLOW.
- The wire coloured BROWN must be connected to the terminal marked with the letter L or coloured RED.
- The wire coloured BLUE must be connected to the terminal marked with the letter N or coloured BLACK.

Ensure that your equipment is connected correctly - if you are in any doubt consult a qualified electrician.

---

## Packing/Unpacking

---

Inspect the shipping container for evidence of damage immediately after receipt. If the shipping container or cushioning material is damaged, it should be kept until the contents of the shipment have been checked for completeness and the camera has been checked mechanically and electrically.

The shipping container should be placed upright and opened from the top. Remove the cushioning material and lift out the contents.

The contents of the shipment should be checked against the packing list. If the contents are incomplete, if there is mechanical damage or defect, or if the camera does not perform correctly when unpacked, notify your Thomson Multimedia Broadcast Solutions sales or service centre within eight days. If the shipping container shows signs of damage or stress, notify the carrier as well.

### Transport

If the unit is being returned to Thomson Multimedia Broadcast Solutions for servicing, try to use the containers and materials of the original packaging. Attach a tag indicating the type of service required, return address, model number, full serial number and the return number which will be supplied by your Thomson Multimedia Broadcast Solutions service centre.

If the original packing can no longer be used, the following general instructions should be used for repacking with commercially available materials:

- a. Wrap unit in heavy paper or plastic.
- b. Use strong shipping container.
- c. Use a layer of shock-absorbing material around all sides of the unit to provide firm cushioning and prevent movement inside container.
- d. Seal shipping container securely.
- e. Mark shipping container FRAGILE to ensure careful handling.

### Storage

The unit may be stored (non-operating condition) in environments within the following limits:

Temperature:	-20 to +50 degrees C
Humidity:	up to 90%
Altitude:	50,000 feet

When stored, the unit should be protected from temperature extremes which may cause condensation, and should also be protected from high levels of dust.

## Opening the Operational Control Panel

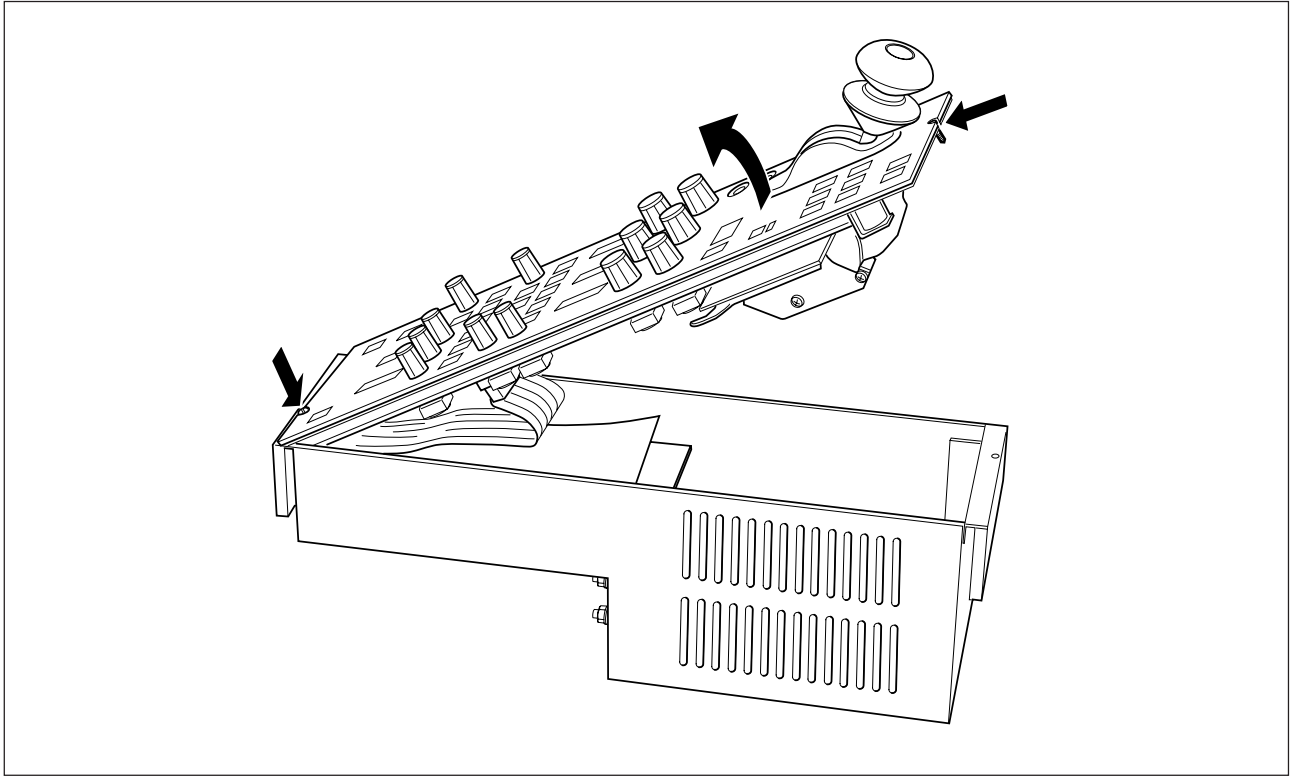

# Mounting in a Desk

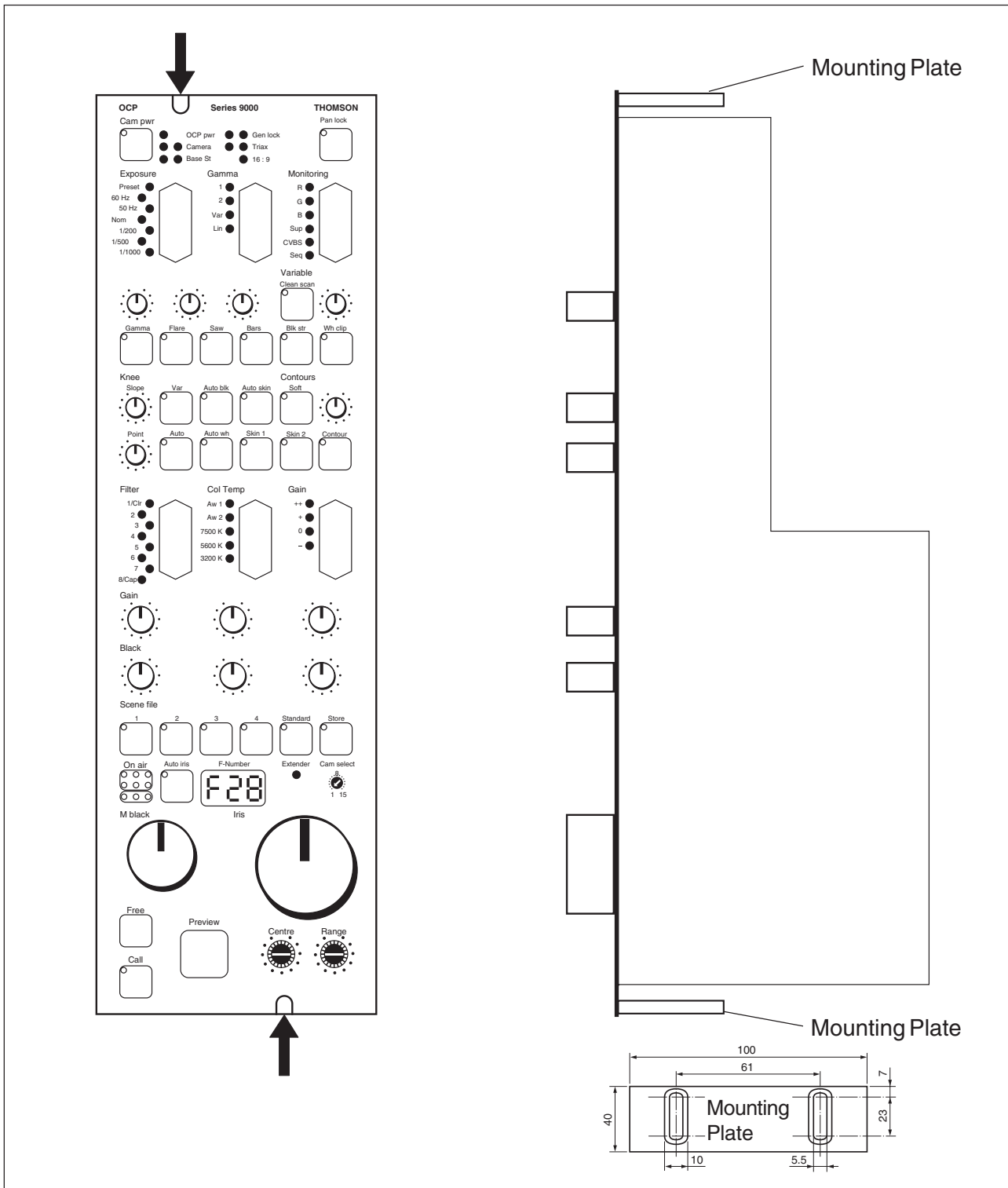

Hole in desk required: 350.7 mm x 106.3 mm.

1. Remove upper panel by loosening screws and disconnecting the flat cable.
2. Remove mounting plates by loosening the two screws securing each plate.



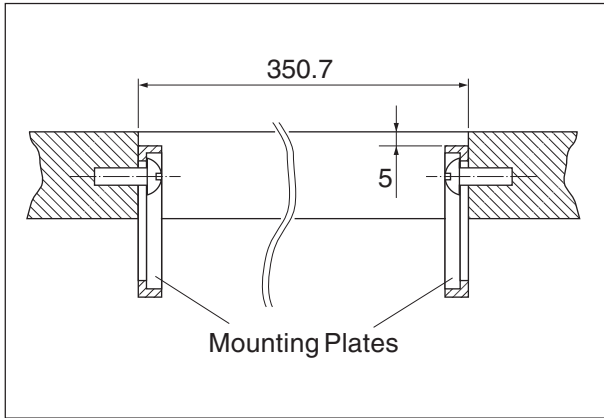

3. Use two screws to attach the mounting plates to the sides of the hole.

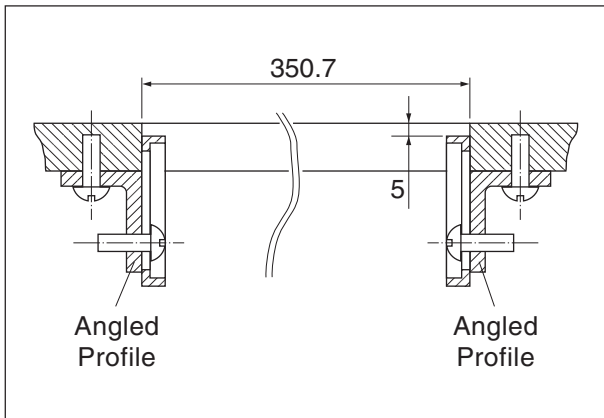

If desk height is less than 20 mm use two angled profiles to mount plates

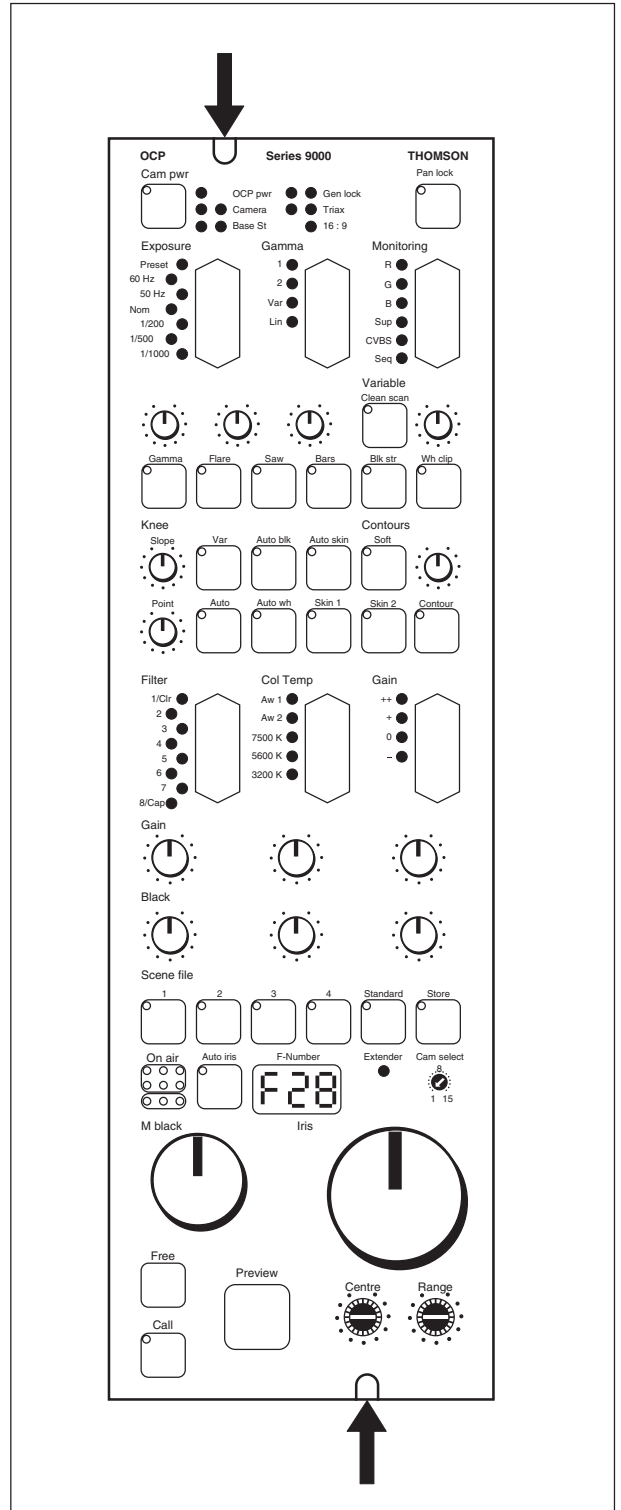

4. Secure operational control box to mounting plates and return upper panel to its original position.

# Mounting in a 19 inch Rack

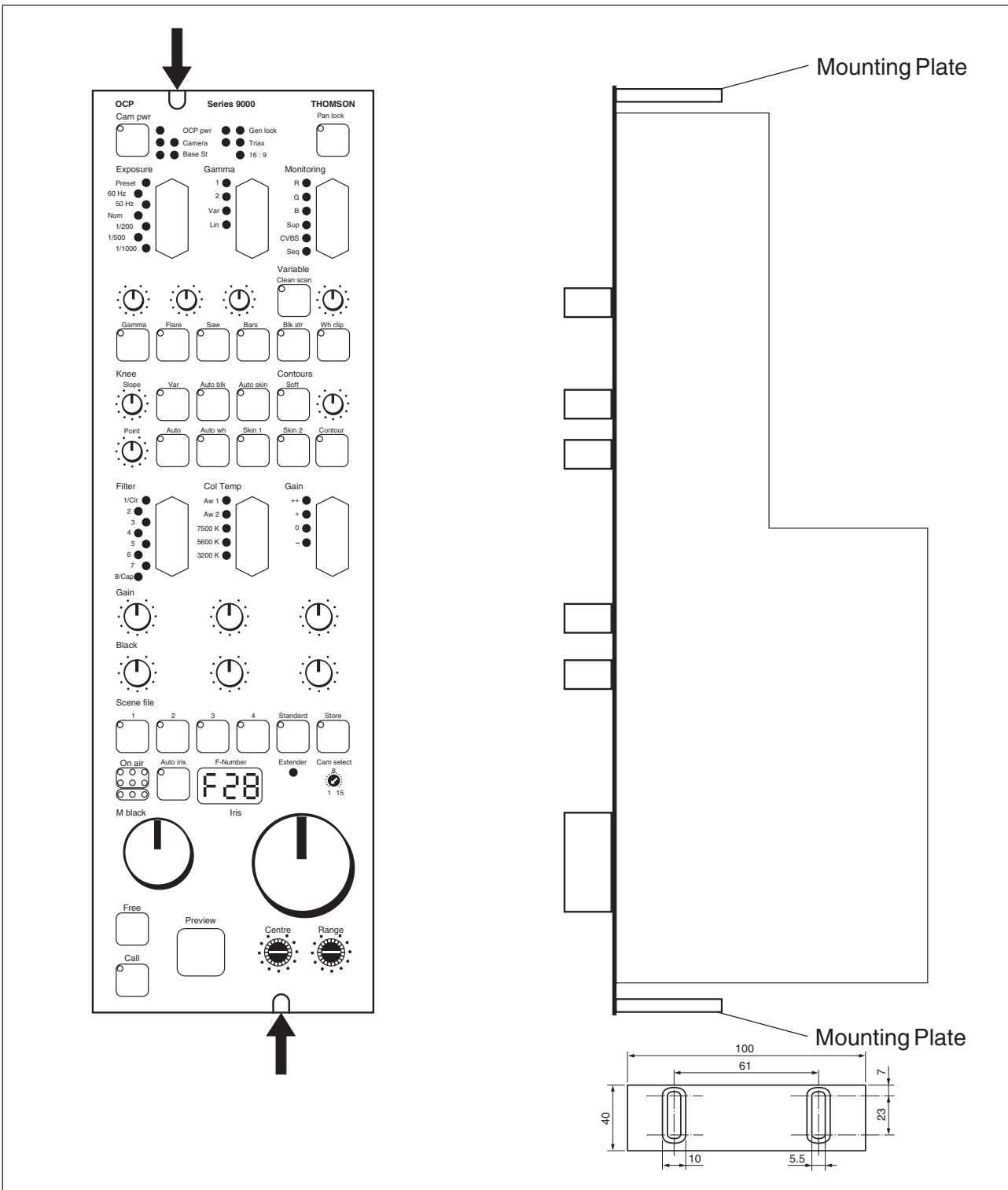

1. Remove upper panel by loosening screws and disconnecting the flat cable.

2. Remove mounting plates by loosening the two screws securing each plate. The mounting plates are not needed for rack mounting.

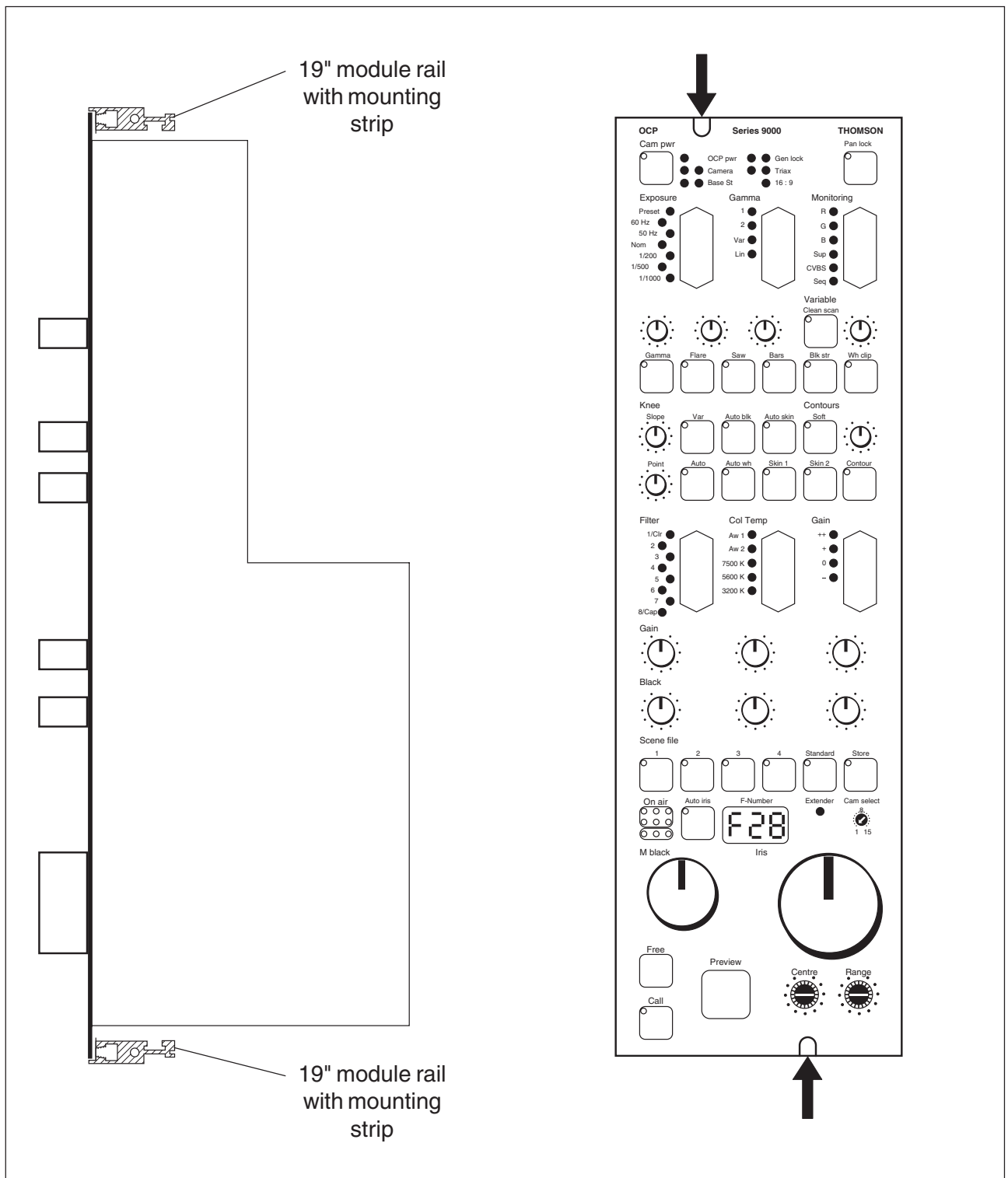

3. Use four screws to mount operational control into the rack using a 19" module rail with mounting strip.

4. Secure operational control box to 19" rack and return upper panel to its original position.

## Internally Selectable Functions

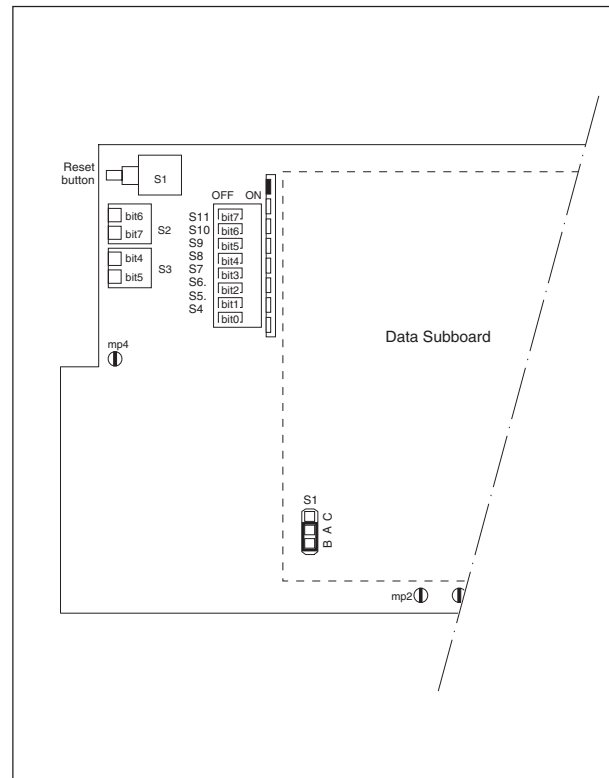
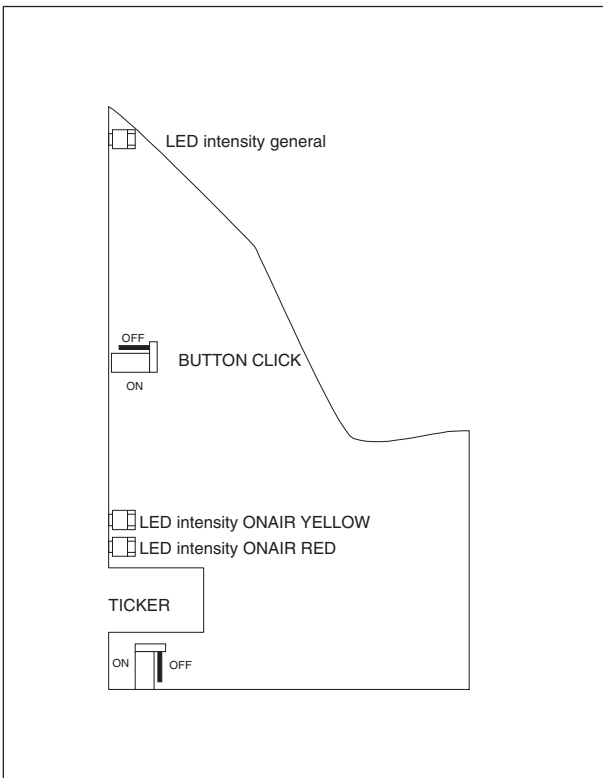

### Call Buzzer

The call buzzer can be disabled by repositioning a jumper which is located on the side of the control panel printed circuit board.

This jumper, S100, has two positions:

- AB: Buzzer Off
- AC: Buzzer On

The operational control panel is normally delivered with the jumper S100 in position AC - buzzer on.

### LED Intensity

There are three LED intensity potmeters on the control panel:

- R25 for LED intensity general,
- R101 for LED intensity On Air Yellow,
- R100 for LED intensity On Air Red.

### Button Click

The button click can be regulated by repositioning jumper S2. This jumper, S2, has two positions:

- AB: Button click On
- AC: Button click Off

The jumper, S2, is located on the left side of the board looking at it from the switch panel side. The operational control panel is normally delivered with the jumper in position AB.

### Watchdog

The function Watchdog On/Off can be selected by the jumper S1 on the Data Subboard.

This jumper, S1, has two positions:

- AB: Watchdog On
- AC: Watchdog Off

The Data Subboard is normally delivered with the jumper S1 in position AB (=Watchdog On).

### User Jumpers

With Jumper S4 you can choose between Complete Panel Lock or beneath Gain Field no Panel Lock.

This Jumper, S4, has two positions:

- AB: Complete Panel Lock
- AC: Beneath Gain Field no Panel Lock

The Data Board is normally delivered with the jumper S4 in position AB (=Complete Panel Lock).

Jumpers S5 through S7 have no function assigned. They should be always in position AB. The jumpers S8 through S11 form the OCP internal address number when the OCP is used in multiple control mode. For correct settings of these jumpers see the Series 9000 Application Guide.

### Dip Switches

The Dip Switches S2 and S3 have factory settings. Never change these settings. For correct settings of these dip switches see the Series 9000 Application Guide.

## Replacing the fuses

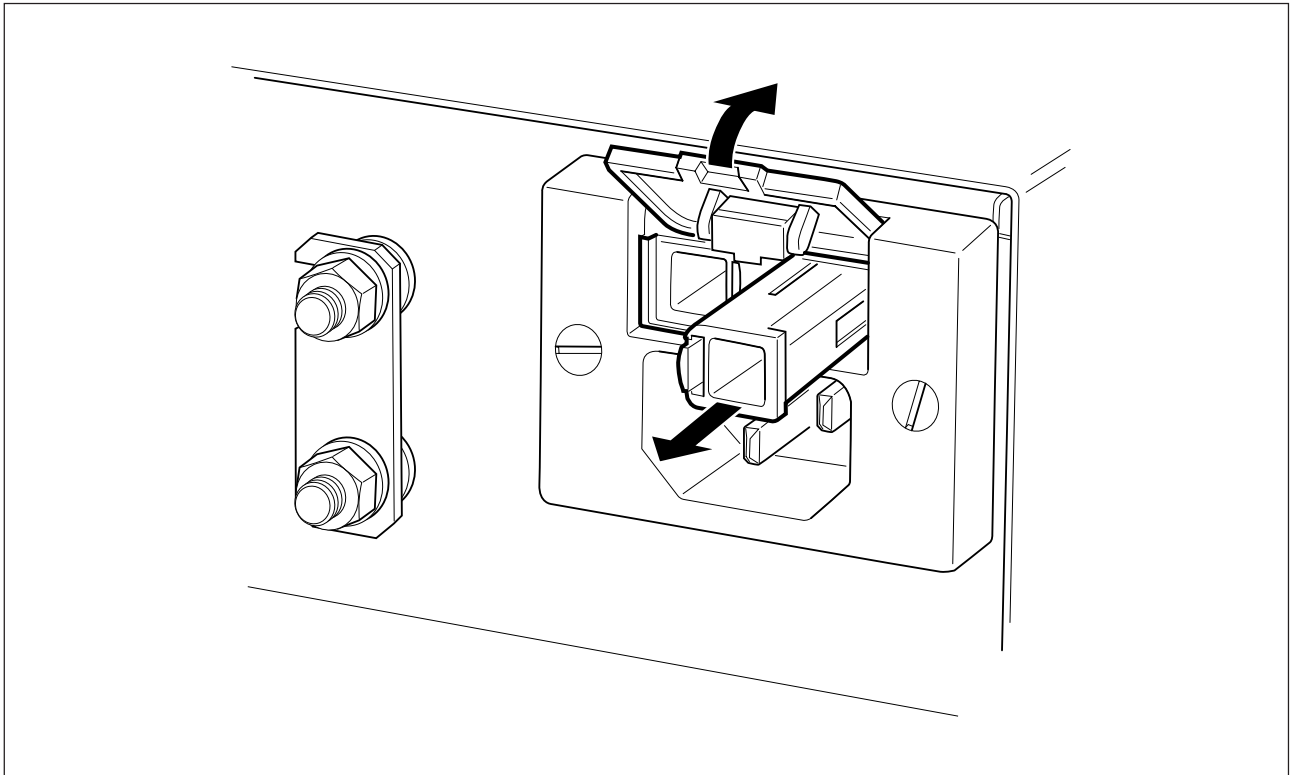

# Interconnections

## LDK 6000HD

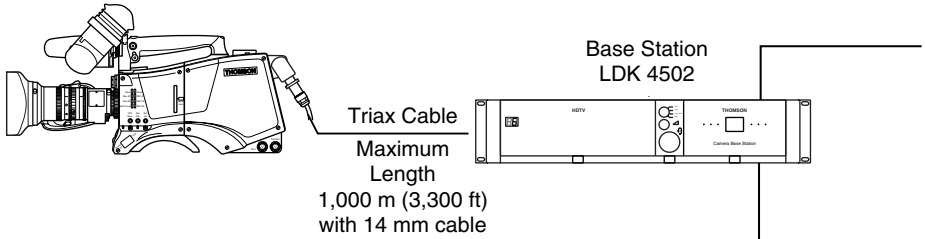

## LDK 6000HD with LDK 4482 SuperXPander

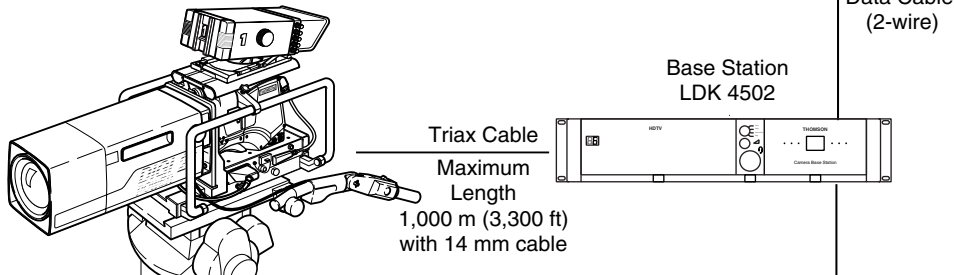

## LDK 200

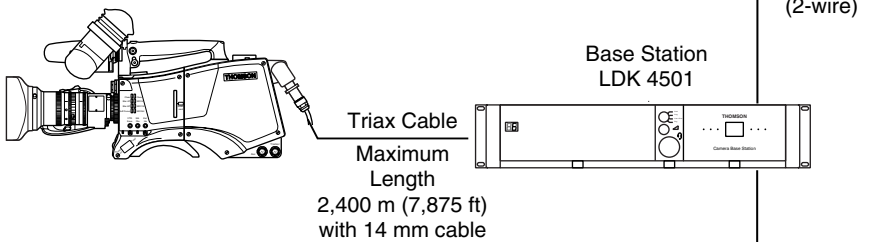

## LDK 23HS mkII (with LDK 4482 SuperXPander)

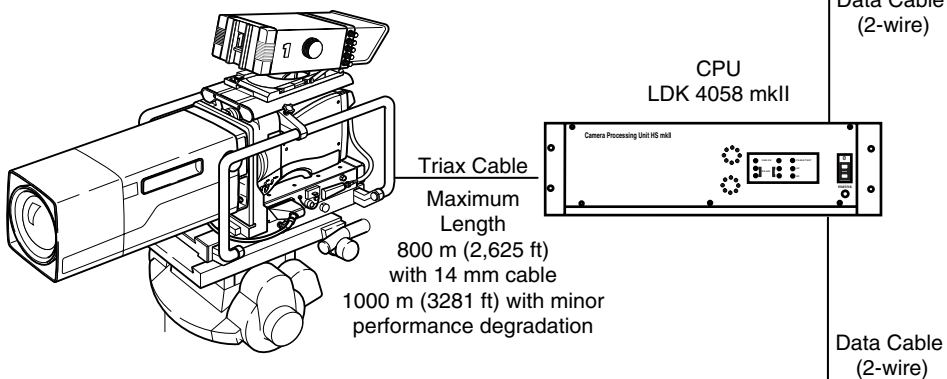

## LDK 20

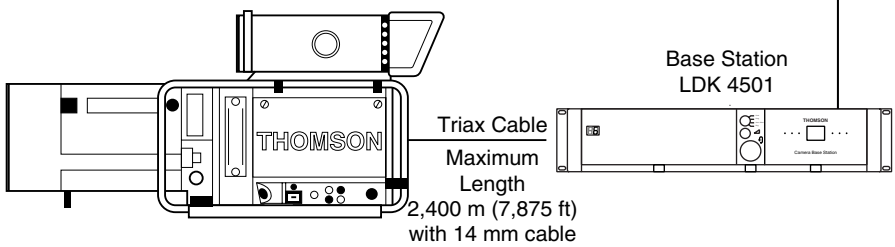

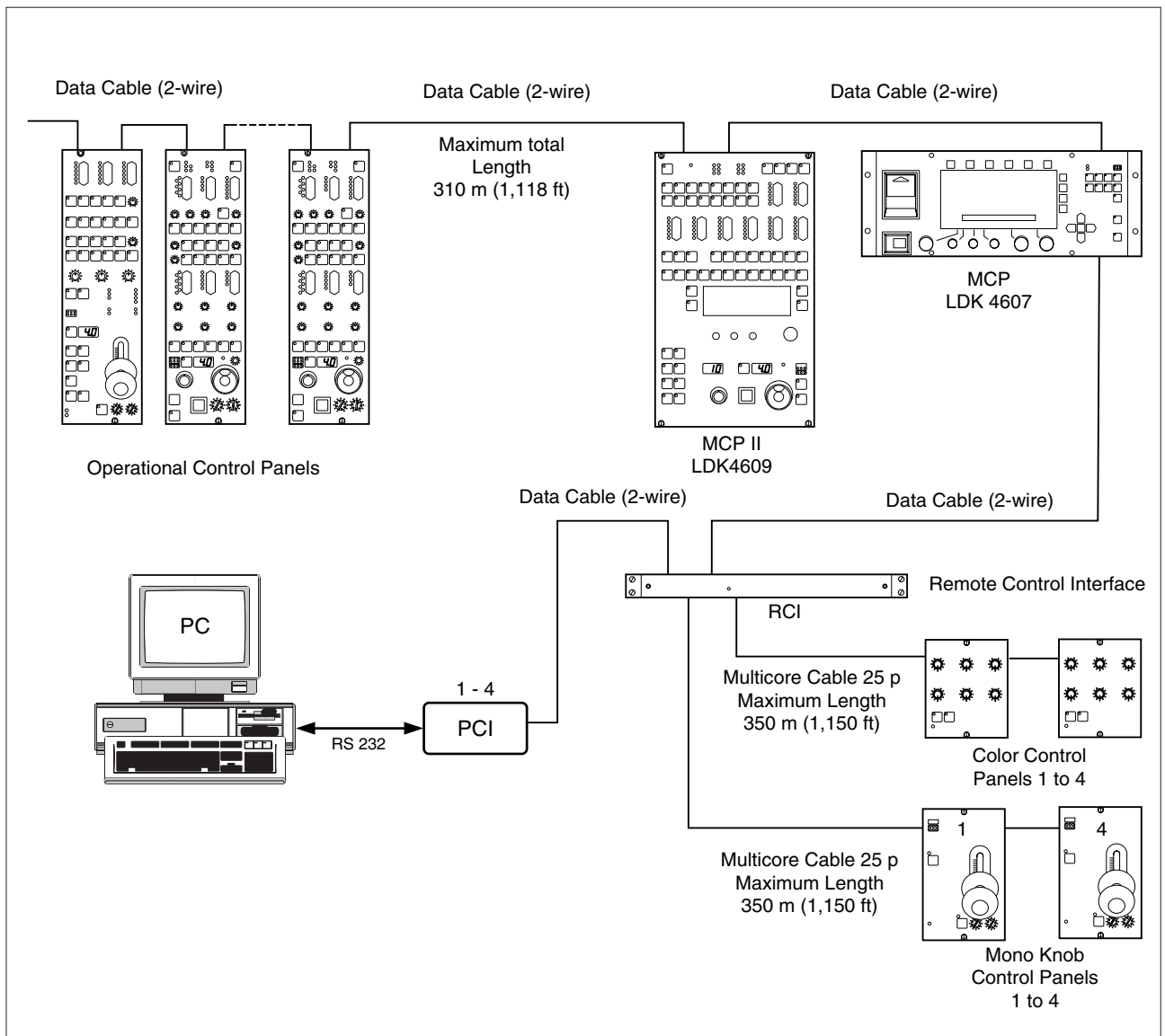

This configuration is the multiple camera Triax mode. The camera is connected to a CPU as in the single camera Triax mode. The data bus is looped-through from CPU to CPU's, Base Stations, OCP's and MCP. The OCP's (Operational Control Panels) are used to control the cameras and a MCP (master Control Panel) can also be connected to extend the control facilities.

The LDK 6000HD cameras are of course HDTV cameras, however, SDTV cameras of the Thomson Multimedia Broadcast Solutions family such as the LDK 20, LDK 100, LDK200, and the LDK 23HS mkII can also be included in this configuration.

**Note:** A maximum of 15 looped-through standard camera systems in one chain can be handled, however, in a multiple system the load of a LDK 23 HS (mkII) is twice the load of a standard camera.

## Two-wire Data Control Bus

---

The two-wire data bus is used to connect all control units in the Series 9000 control system. The data cable loops-through from one unit to the other. The order of connection is not important, however, the total length of the cables must not exceed 310 meters (1,118 ft).

Each unit connected directly to the data bus, either Base station, camera head or OCP, is identified by a number. In order to ensure, for example, that OCP 1 controls the camera connected to Base station 1, the same unique number must be assigned to both OCP 1 and Base station 1. The assignment number is set internally on the units during installation.

The assignment number of a camera head connected to a Base station is automatically set to the number of the Base station to which it is connected. The number on the Base station, which is connected to the data bus, must be set to the number of the assigned control panel.

It is important to set a unique number for each Base station/OCP group as unpredictable control situations could arise otherwise.

The MCP is also connected to the data bus, however, it is not necessary to set an internal assignment number. The camera or cameras to be controlled are selected on the MCP front panel itself when operating the unit.

### **Note**

A maximum of 15 looped-through standard camera systems in one chain can be handled, however, in a multiple system the load of a LDK 23 HS (mkII) is twice the load of a standard camera.



## Connectors and Cables

### MCP Rear Connector Panel

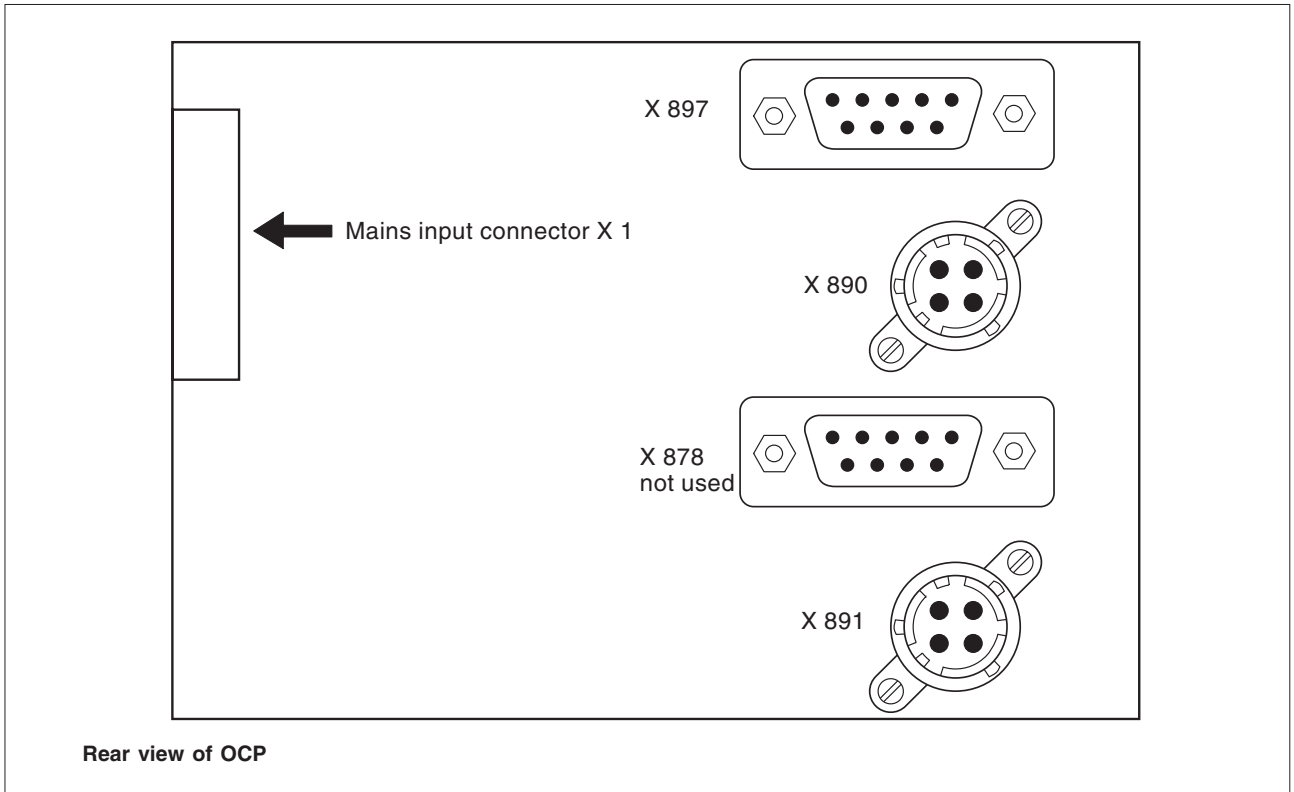

### Mains Input Connector

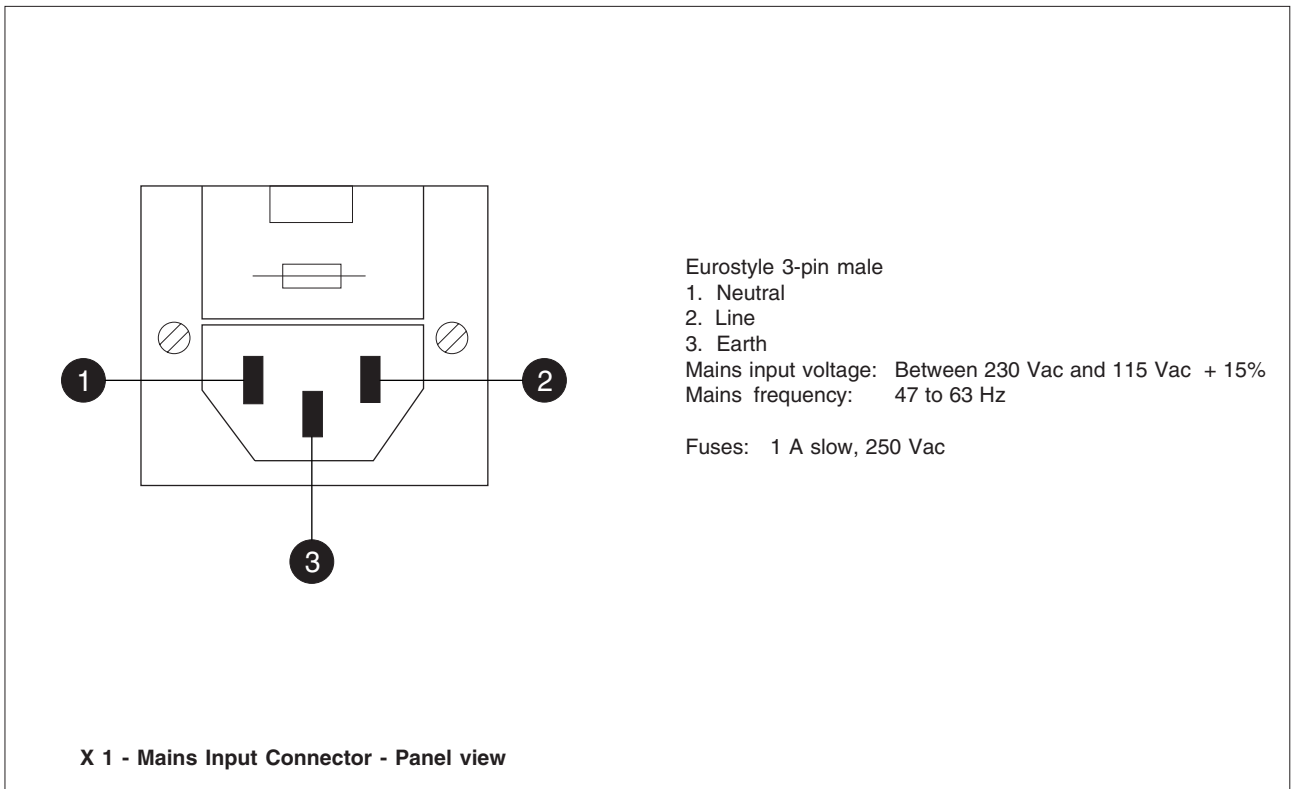

## Preview Connector

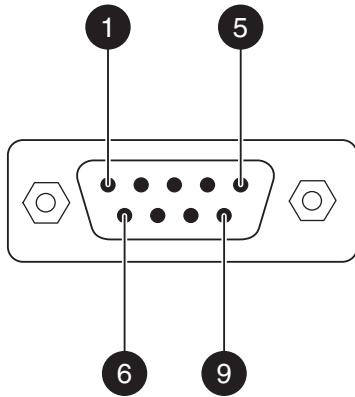

X 897 - Preview Connector - Panel view

9-pin male, shielded cable

1. Preview 1A
2. Preview 1B
3. Preview 1C
4. Not used
5. Not used
6. Not used
7. Not used
8. Not used
9. Shield

Shield of cable directly to the pin marked shield.

A 9-pin female cable connector is available under part number 2422 022 06216.

The cable hood for this connector is available under part number 2422 021 02467.

Preview switch not pressed: 1A connected to 1C  
Preview switch pressed: 1A connected to 1B

## Data Connectors

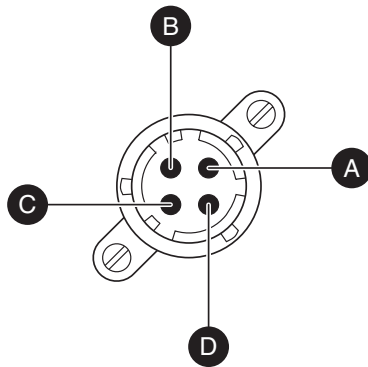

X 891/892 - Data Connector - Panel view

Souriau 4-pin male, shielded cable

- A. Data
- B. Data not
- C. Not Connected
- D. Shield

Shield of cable to the pin marked shield

Note:

Data cable order nr.:

LDK 8113/01 = 1 meter

LDK 8113/10 = 10 meters

LDK 8113/99 = 100 meters

# Dimensions

