

---

# LDK 5000

## Digital Triax Camera

### Operator's Manual

---

## Contents

---

About this Manual .....	ii		
<b>Introduction .....</b>	<b>1-1</b>	<b>Location of Controls and Functions .....</b>	<b>4-1</b>
Technology .....	1-2	Power Supply .....	4-2
Features .....	1-3	Security and Access .....	4-3
Smart Card .....	1-4	Video Functions .....	4-4
Important Precautions .....	1-5	Monitoring Functions .....	4-6
<b>Assembling the Units .....</b>	<b>2-1</b>	Viewfinder .....	4-7
Transport Case .....	2-2	Viewfinder Indicators .....	4-8
Lens .....	2-3	Audio .....	4-9
2-inch Viewfinder .....	2-4	Intercom .....	4-10
2-inch Viewfinder Accessories .....	2-5	Control Functions .....	4-11
Zoom Controls .....	2-6	Auxiliary Functions .....	4-12
Microphone .....	2-7	<b>Shooting .....</b>	<b>5-1</b>
Tripod Adapter Plate .....	2-8	Using the Camera .....	5-2
SuperXPander .....	2-9	Colour Bar .....	5-3
Shoulder Pad .....	2-10	Gain selection .....	5-3
Rain and Off-use Cover .....	2-10	Optical filter selection .....	5-3
Script board .....	2-11	Colour temperature selection .....	5-4
Top Light .....	2-11	Auto-White Balance .....	5-4
<b>Configurations .....</b>	<b>3-1</b>	Shooting Screens .....	5-5
LDK 5000 Configurations .....	3-2	Exposure Time .....	5-6
Single camera triax mode .....	3-3	<b>Using the Menu System .....</b>	<b>6-1</b>
Multiple camera mode .....	3-4	Introduction .....	6-2
Two-wire Data Control Bus .....	3-6	Systems Menu .....	6-3
Other Control Features .....	3-6	<b>Appendix .....</b>	<b>A-1</b>
Intercom Routing .....	3-7	System Menu Structure .....	A-3
Audio .....	3-8	List of System Menu Functions .....	A-14
		List of Abbreviations .....	A-16

# About this Manual

---

This operator's manual is part of a complete documentation set for the camera which also includes a Technical Manual, and a Service Manual.

## **Purpose of this manual**

The purpose of this manual is to present a detailed description of how to operate the LDK5000 Digital Camera equipped with an LDK 5440 Triax adapter. It provides the information necessary to use the camera in different configurations and with various attachments. With this manual it is possible to discover all the operating features of the camera and so use it to its full potential. The manual should be used together with the camera to explore and learn about the many sophisticated control functions available.

## **Intended audience**

This operator's manual can be used by inexperienced camera operators who are new to Thomson cameras as well as those who have previous experience of operating cameras. The guide is so designed that it can be used as an introduction to those who are new to the camera, as a simple procedural guide to those who wish to set-up and start shooting immediately, and as a reference work to be consulted as required during the long life of the camera.

## **Structure of this manual**

The manual is divided into six sections and an appendix:

### **Section 1: Introduction**

This section outlines the technology used in the LDK 5000 camera and how this translates into a practical, useable camera. It lists the main features of the camera and also the precautions that must be taken into account when using it.

### **Section 2: Assembling the Units**

Section 2 provides information on the physical assembly of the camera and on how accessories can be used to expand the camera's range. The mounting of accessories and packing for transport is also explained.

### **Section 3: Configurations**

The LDK 5000 is a triax camera and this section describes the various ways that it can be used. Information on the cables, control panels and the control bus is also provided as is information on the main video and audio signal paths through the system.

### **Section 4: Location of Controls and Functions**

This section shows the physical location of the controls and connectors on the camera. These are grouped according to their function so as to provide a quick reference guide to the operation of a particular aspect of the camera.

### **Section 5: Shooting**

This section contains information on the practical use of the camera using the viewfinder display and the switches to control the camera.

### **Section 6: Operating the Menu System**

Because the LDK 5000 offers such a wide range of functions, this section describes the structure of the control system.

### **Appendix**

The appendix contains a list of the menu functions available on the camera.

---

# Section 1

## Introduction

*This section outlines the technology used in the LDK 5000 Triax camera and how this translates into a practical, useable camera. It lists the main features of the camera and also the precautions that must be taken into account when using it.*

---

### Contents

Technology .....	1-2	Smart Card .....	1-5
Features .....	1-4	Important Precautions .....	1-6

The LDK 5000 is a digital camera head using 2/3-inch FT CCD sensors. The camera is combined with the Triax adapter. This flexible camera is equally at home in the studio or out on location.

The sensors have a high dynamic range and high linear sensitivity across all camera lens apertures. They are based on Frame Transfer technology, which ensures that there is neither lag nor smear.

## Digital Processing

The advanced digital processing of the camera is based on 12-bit A/D conversion and 22-bit internal processing. Two DSPs combine all major camera functions in the digital domain, including knee, gamma, matrix and colour correction.

The intelligent continuous automatics facility provides automatic control of black levels and black shading. Each sensor provides black reference signals that are used to monitor temperature changes. This means that continuous automatic correction is applied without operator intervention.

Colorimetry is selected by means of a variable 6-point digital matrix or via preset matrices. Digital gamma circuits provide a wide range of standardized gamma curves and enable soft contrast in black scenes to be enhanced, together with hard contrast and saturated colour in bright scenes. The matrix and gamma sequence is software programmable for precise colour matching.

## Film-like characteristics

The pivoting knee circuit adapts both the knee point and the compression ratio according to the highlight content of the picture to emulate the softly limiting S-shaped transfer characteristics of film. Digital True Colour Knee circuitry maintains the correct hue for compressed highlights, reproducing colours faithfully, even overexposed skin tones.

Digital contrast circuitry provides a black stretch function for more detail in black areas and a black press function for improving the contrast impression by simulating the S-curve of film.

## SuperXPander

The SuperXPander large lens adapter together with the optional 7-inch high resolution viewfinder turns the portable triax camera into a full-featured studio camera for studio and EFP situations.

## Advanced Triax Features

Triax, which is a further development of the Emmy Award winning triax transmission system, makes the camera compatible with industry standard triax cables. This allows the reuse of existing, reliable and valuable cable inventories.

Triax allows video transmission and remote control of cameras up to a distance of 3300 ft (1000 meters) and beyond, using industry standard 14mm triax cables. It is based on 30MHz full-bandwidth 4:2:2 transmission (Y/Cr/Cb components).

The double side band modulation technique used in combination with Y/Cr/Cb transmission ensures linearity, resolution and an optimal signal-to-noise ratio over the maximum cable length. Bandwidth efficient channel combining and equalization techniques minimize cross-talk and interference. Teleprompter and viewfinder signals maintain high performance with relatively long cable lengths.

The communication facilities provide for two-wire or four-wire high quality intercom signals. Full camera control is provided via the existing Series 9000 Universal Camera Control system.

The Triax adapter is equipped with a rotary triax connector which provides freedom of movement during portable use of the camera and protects the connector from being damaged in near-floor conditions.

## Triax Base Station

The Triax Base Station, besides high definition outputs, optionally offers simultaneous high-end SDTV outputs.

## Features

---

- The CCDs have 9.2 million pixels, with 1920 (H) x 4320 (V) effective picture elements.
- Frame Transfer technology ensures no smear.
- 12-bit A-to-D and more than 22 bit digital processing with unique software programmable video path.
- Superior all digital highlight handling with a wide dynamic range.
- Unique circuitry for pivoting knee and True Colour Knee.
- Wide range of presets and variable 6-point digital matrix assure accurate colour matching.
- Fluorescent light matrix.
- Digital gamma with unique standard preset values and highest accuracy.
- Intelligent Continuous Automatics black levels, black shading and video levels - no set-up time required.
- Digital contrast with standard black stretch and black press.
- International standard 2/3-inch lens interface.
- Optical servo-controlled four-position neutral density filter wheel.
- Optical servo-controlled effect filter wheel with soft focus, four-point star and six-point star filters.
- Electronic colour filter can be used for creating a special look (warm / cold) of a scene, or for a smooth colour temperature control around the white balance setting.
- Smart card for personal settings and security.
- Owner card for setting user levels, and for copying and storing control settings.
- Protected, easy-to-operate controls and switches with read-out of all settings.
- Viewfinder status read-out of primary camera functions.
- Clean scan feature allows capture of computer and other monitor pictures.
- Digital RS 232 interface to PC.
- Script board facilities.

### Triax adapter

- Triax allows video transmission and remote control of cameras up to a distance of 3300 ft (1000 meters) and beyond, using industry standard 14mm triax cables
- Full camera control via the Series 9000 Universal Camera Control System.
- Two-wire or four-wire intercom to international standards.

### Optional

- 2" Viewfinder, additionally optional wide angle ocular and microphone kit for portable use of the camera system in studio and EFP situations.
- Integral zoom control in handgrip makes awkward ground-level shots easy.
- SuperXPander and optional 7" Viewfinder for use as a full-featured studio camera in studio and EFP situations.
- High-end SDTV outputs (both digital as well as analog) on the Base Station.
- Script board.
- Tripod adapter plate.
- Smart-Touch™ for instant access to predefined shooting characteristics.
- A robust flight-case for a secure transport of your camera.

# Smart Card

Three smart cards are delivered with each camera. These comprise of two user cards and one owner card.

The owner's smart card has three functions:

- As an access control device to the security settings of the camera.
- As a storage device for four scene files.
- As a storage device for two operator files.

The owner card is unique to every camera. Owner card and camera must have the same serial number.

The user smart card has two functions:

- As a storage device for four scene files.
- As a storage device for two operator files.

## Access control

The owner card is used to set the user level. There are four user levels present in the camera. These restrict access, in varying degrees, to the operational controls. The Appendix indicates which functions are available at each user level.

(The owner card also gives access to a service level; refer to the Technical Manual for more information about this level.)

## Scene files

Both the user card and the owner card allow four different scene files to be stored on the card. The recall and storage of a scene file is carried out via the Files menu of the menu system. A scene file contains information relating to the video settings.

## Operator files

Both the user card and the owner card allow two different operator files to be stored on the card. The recall and storage of an operator file is carried out via the Files menu of the menu system. An operator file contains information relating to the set-up of general camera preferences.

**Note:** Only use an original camera card.  
Store the owner card in a safe place.

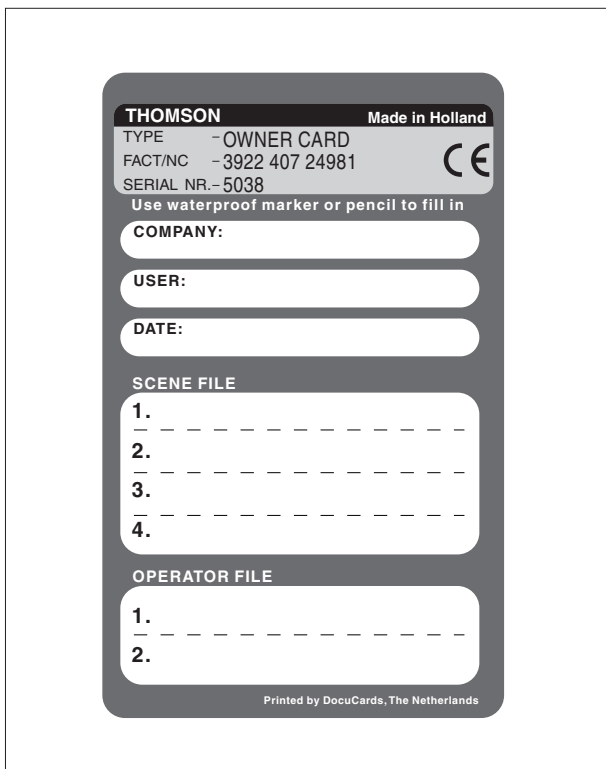

Owner card

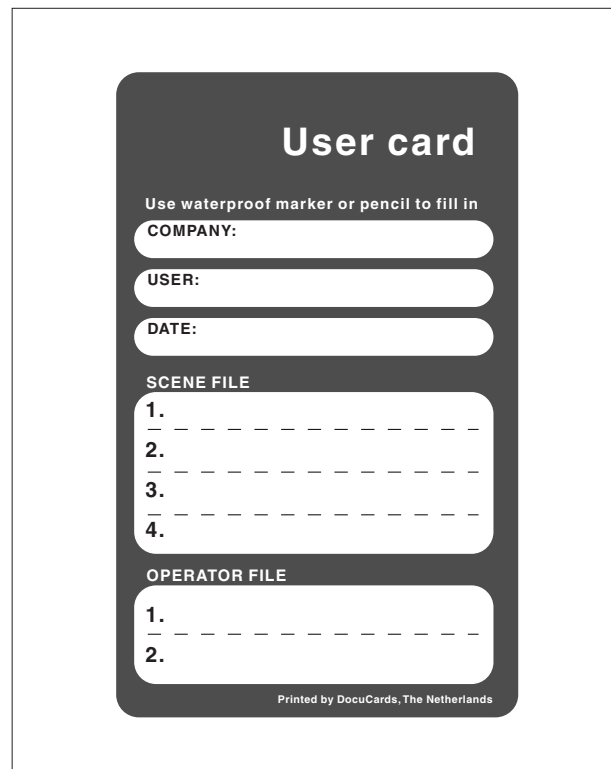

User card

## Important Precautions

---

To ensure continual high performance from the camera take the following precautions into consideration:



Avoid very damp places. If the environment is wet or damp a rain cover must be used to protect the unit.



Do not subject the unit to severe shocks or vibration.



Do not expose the camera to extremes of temperature.



Do not leave the unit in direct sunlight or close to heating appliances for extended periods.



Do not allow sunlight to shine into the viewfinder.

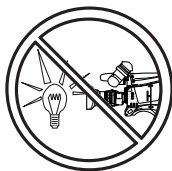

Avoid extreme highlights as these can cause various kinds of optical reflections.

### WARNINGS

If the unit is in a wet or damp environment, a rain cover must be used to protect it for personal safety reasons (EN60065). The rain cover supplied with the unit protects it according to safety specification EN60529 up to level IPX2 (spraying water).





---

## Section 2

### Assembling the Units

*Section 2 provides information on the physical assembly of the camera and on how accessories can be used to expand the possibilities of the camera. The mounting of accessories and packing for transport are also explained.*

---

#### Contents

Transport Case .....	2-2	Tripod Adapter Plate .....	2-8
Lens .....	2-3	SuperXPander .....	2-9
2-inch Viewfinder .....	2-4	Shoulder Pad .....	2-10
2-inch Viewfinder Accessories .....	2-5	Rain and Off-use Cover .....	2-10
Zoom Controls .....	2-6	Script board .....	2-11
Microphone .....	2-7	Top Light .....	2-11

## Transport Case

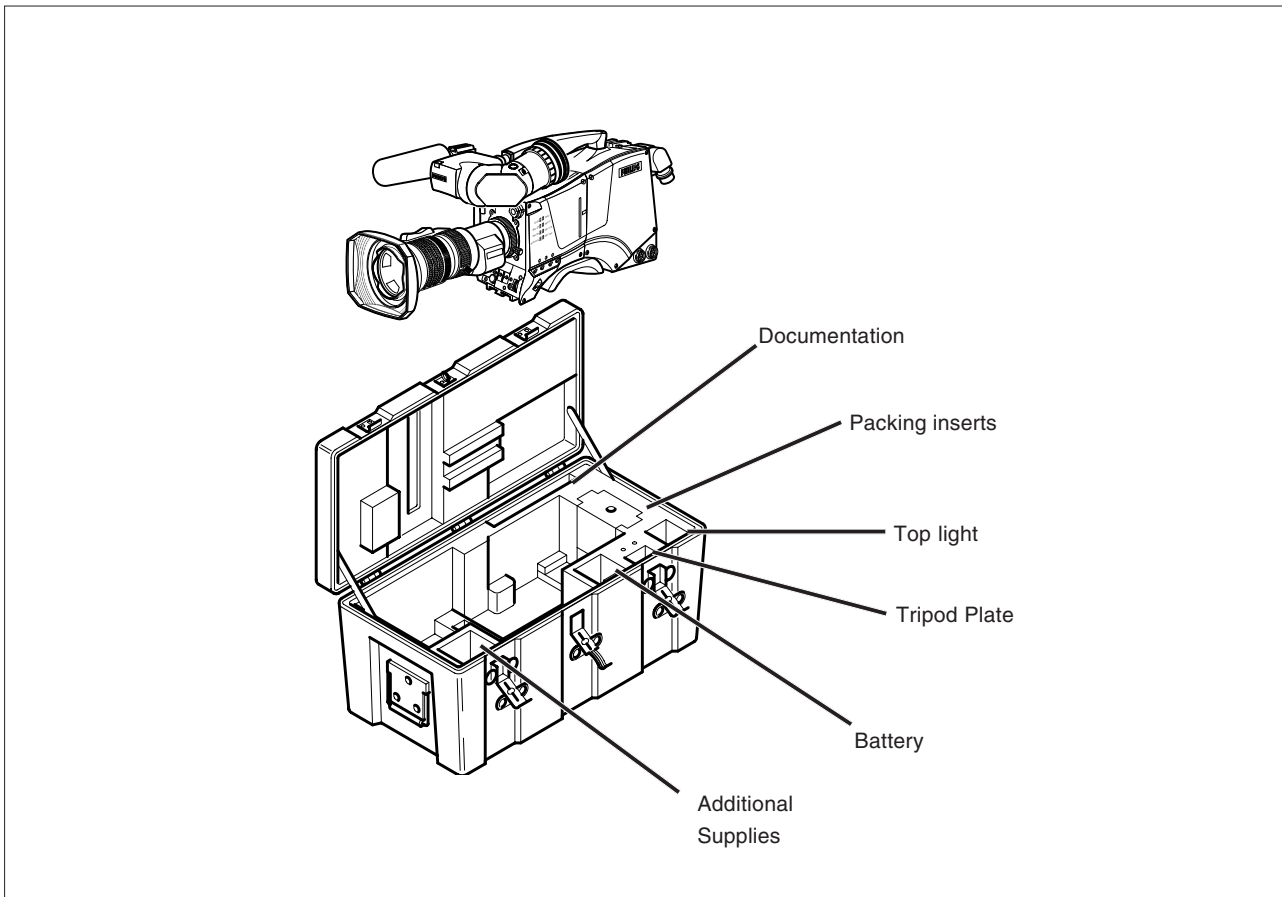

It is important to protect your camera against damage when transporting it. To do this, a transport case (LDK 5020/00) is optionally available for the camera, lens, viewfinder and some accessories.

The camera is packed in the transport case as shown in the figure above. This ensures that the camera is not damaged during transport.

Turn the 2-inch viewfinder downwards so that it does not protrude above the top of the camera.

Several foam packing inserts are provided to enable different configurations of the camera to be packed securely. These inserts are used to support the rear of the camera. Make sure you use the correct foam insert for your particular configuration.

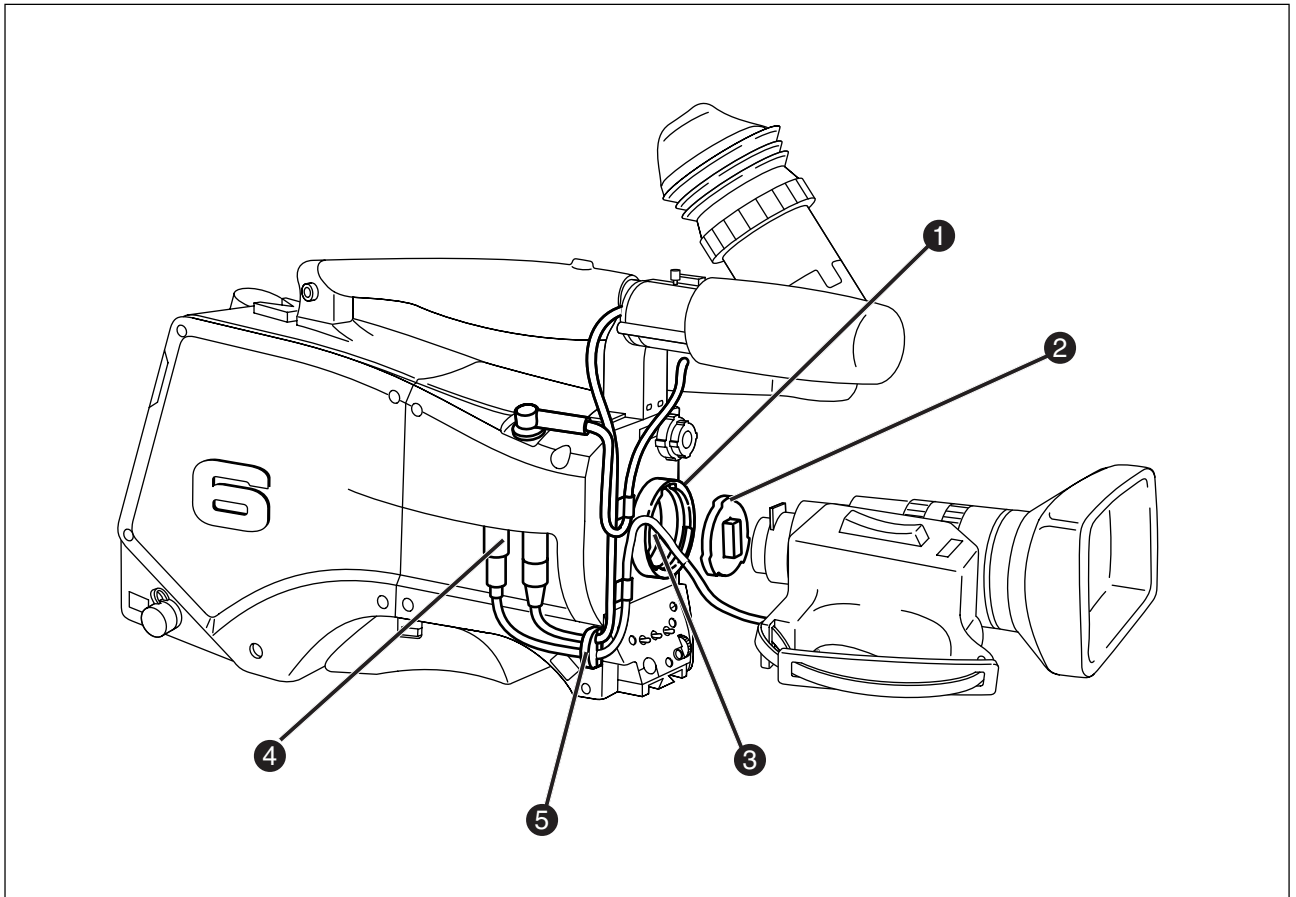

To attach a lens to the camera head proceed as follows:

- a. Ensure that the lens locking ring (1) is in the unlocked position - turned counterclockwise.
- b. Remove the dust protection cap (2).
- c. Slot the lens into the lens mount (3).
- d. Turn the lens locking ring (1) clockwise to lock the lens in place.
- e. Connect the lens cable to the lens connector (4) at the right side of the camera.
- f. Place the lens cable into the bottom clip at the front of the camera and clip (5) located at the side. (Pull and twist clip (5) to open it.)

### CAUTION

Do not attach a lens weighting more than 5 kg to the camera without a support.

When a new lens is fitted to the camera it may be necessary to carry out some adjustments to optimize its use, for example, back focus or shading. For more information about these adjustments refer to Section 5 and to the lens manufacturer's documentation.

**Note:** Always mount the dust protection cap when the lens is not connected to the camera.

## 2-inch Viewfinder

### Mounting the 2-inch viewfinder and microphone holder

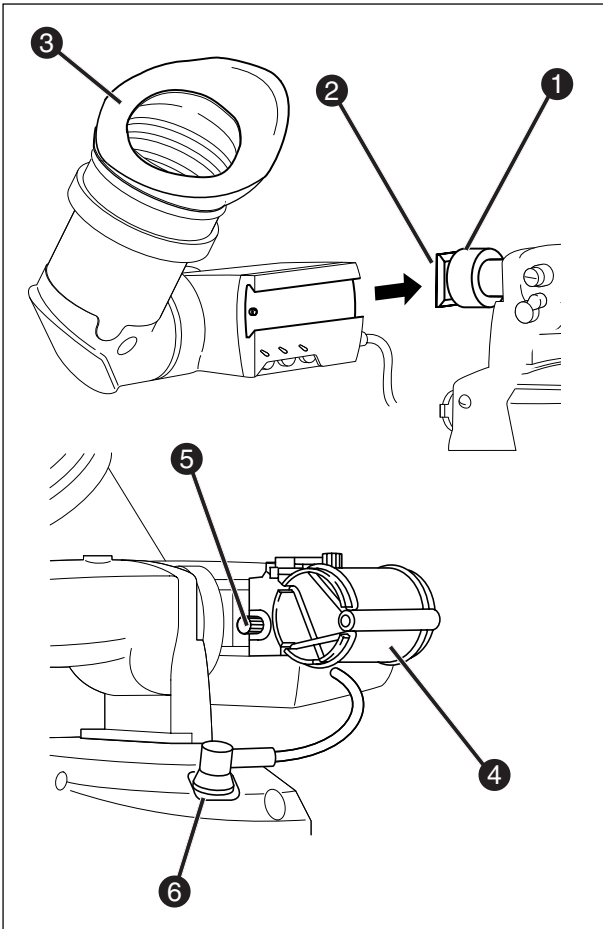

To mount the 2-inch viewfinder proceed as follows:

- Loosen locking ring (1) of viewfinder support bracket (2) at the front of the camera handle. (As seen from the rear of the camera, turning the locking ring counterclockwise moves it towards the handle.)
- Slide the viewfinder onto the viewfinder support bracket.
- Tighten the locking ring (1) by turning it clockwise (as seen from rear) so that the viewfinder is mounted securely to the support.
- Connect the viewfinder cable to the viewfinder connector socket (6) at the top right of the camera.
- Slide the microphone holder (4) onto the viewfinder and secure with the knurled screw (5).

#### CAUTION

Always fit the microphone holder (4) as it functions as a safety stop for the viewfinder.

- To improve the comfort of the skin contact when using the viewfinder, fit the optional eye piece cover (3922 405 00461) to the rubber eyepiece (3).

### Positioning the 2-inch viewfinder

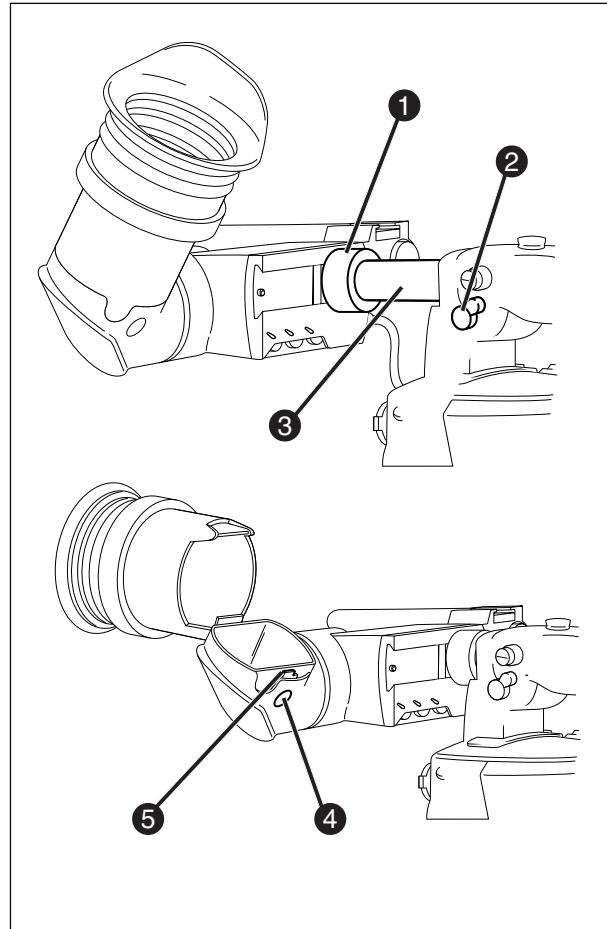

The horizontal position of the viewfinder can be adjusted as follows to suit your requirements:

- Loosen the locking ring (1). (As seen from the rear of the camera, turning the locking ring counterclockwise moves it towards the handle.)
- Slide the viewfinder horizontally along the rail to the desired position.
- Tighten the locking ring (1) by turning clockwise.

The dioptre hood and eyepiece of the viewfinder can be rotated vertically.

The viewfinder can be positioned backwards and forwards along the camera axis. Loosen the support bracket round bar retaining lever (2) and slide the round bar (3) forwards or backwards. When the desired position is reached tighten the support bracket round bar retaining lever (2) again.

To use the viewfinder at a distance press the button (4) below or above the eyepiece tube and swing it free of the associated clip (5). The display can now be seen from further away.

## 2-inch Viewfinder Accessories

### Wide angle eyepiece

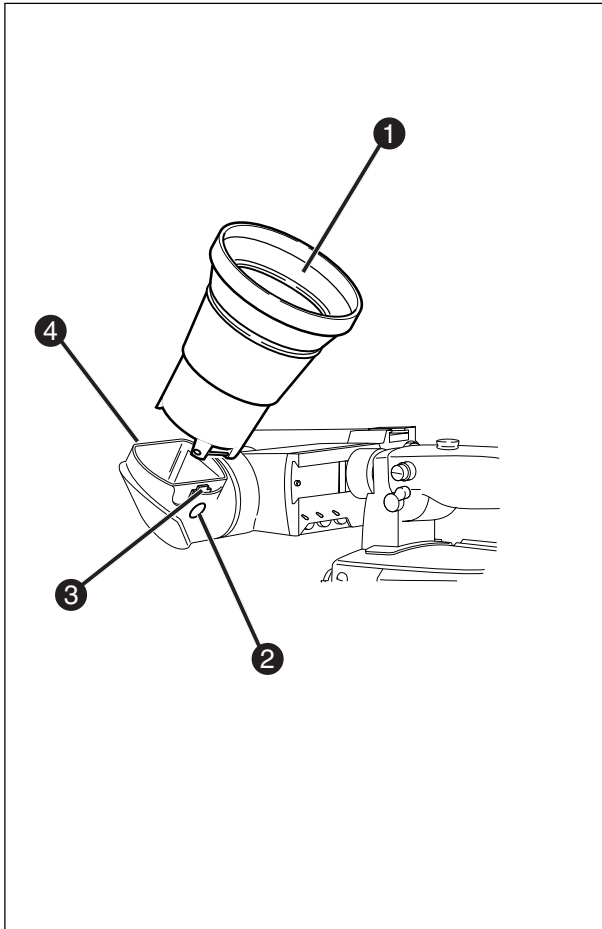

If you regularly use the viewfinder at a distance, for example, when you use the camera in the hand-held position, it is recommended that you fit the optionally available wide angle eyepiece (LDK 5390/00).

To fit the wide angle eyepiece proceed as follows:

- Hold the eyepiece **(1)** securely.
- Press the button **(2)** below the eyepiece tube and swing it free of the button clip **(3)**.
- Press the button **(4)** above the eyepiece tube and remove the eyepiece.
- Fit the wide angle eyepiece **(1)** to the two clips **(3)** ensuring that they both click into place.

### Left eye adapter

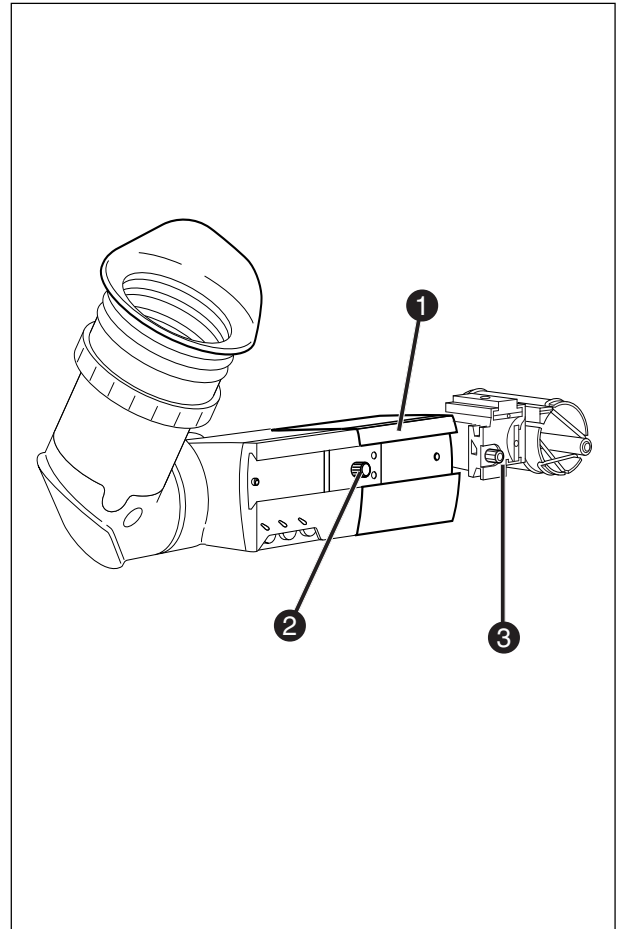

A left eye adapter is optionally available (LDK 5390/10) to allow the viewfinder to be used with the left eye.

Before mounting the viewfinder onto the camera, attach the left eye adapter **(1)** to the viewfinder and secure it using the screw **(2)**. Do not forget to mount the microphone support bracket **(3)** at the end of the left eye adapter.

## Zoom Controls

---

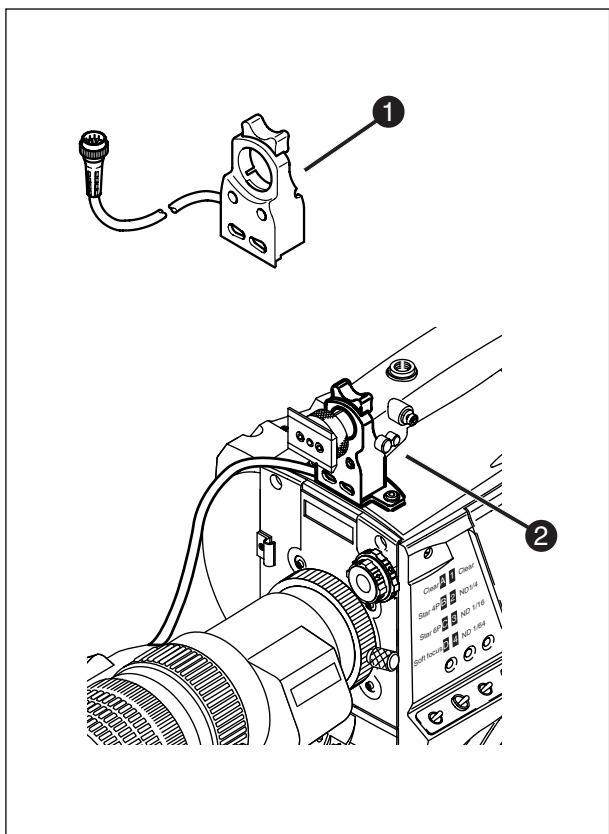

An optional zoom control unit **(1)** can be mounted on the carrying handle. The three available versions for different types of lens are:

- LDK 6113 / 16 for Angenieux..
- LDK 6113 / 26 for Canon.
- LDK 6113 / 36 for Fujinon.

This control unit not only controls the zoom but also has mini-button controls for the VTR start/stop function and the VTR Ret. function. These are located under the front of the carrying handle **(2)**.

The instructions for mounting the zoom control unit and the function of the controls are supplied with the unit.

## Microphone

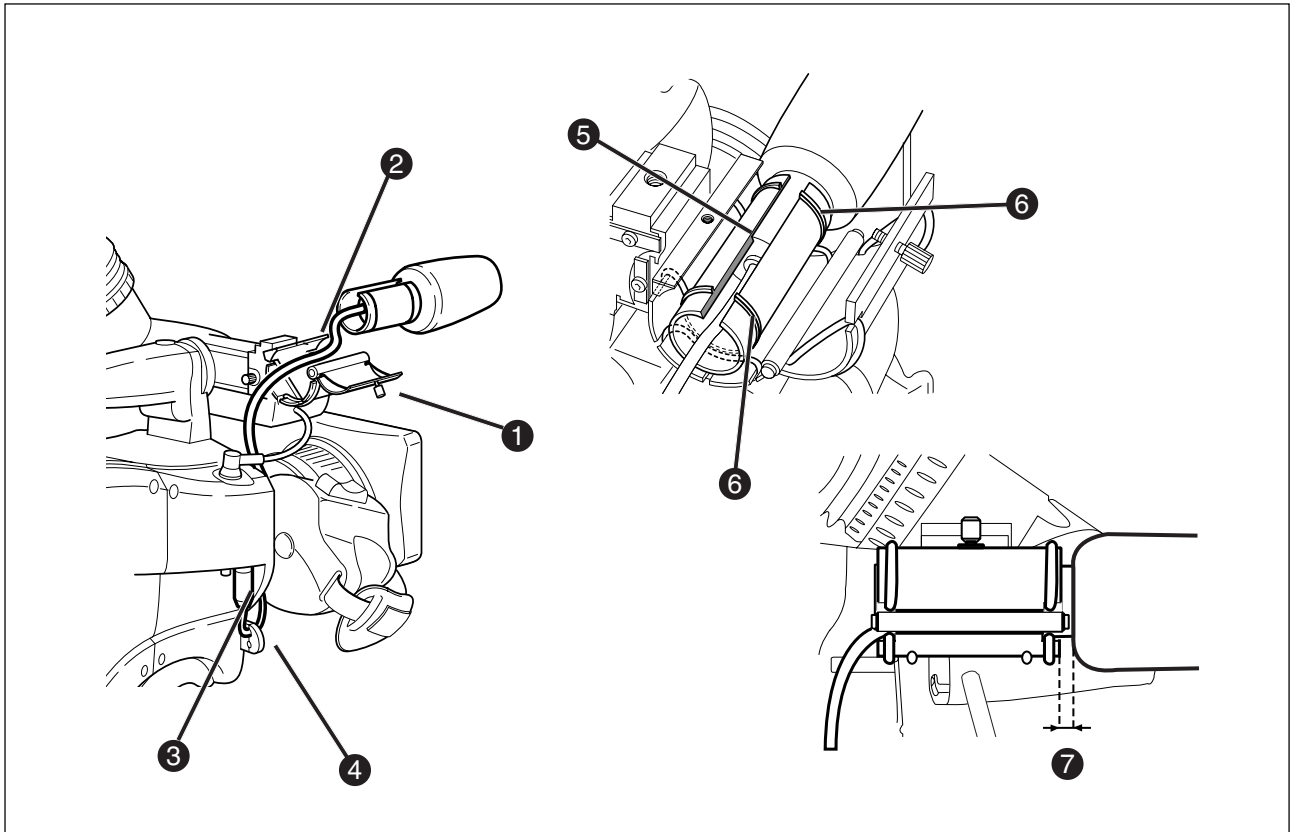

To attach the optional microphone (AJ MC700) to the camera proceed as follows:

- a. Open the microphone holder by unscrewing the knurled screw (1) of the microphone support bracket (2) on the viewfinder and open.
- b. Slide the microphone into the split tube until the microphone shoulder reaches the mark (5) in the tube.
- c. Place the tube with the microphone into the holder with the split facing upwards.
- d. Ensure that the rubber supports at the back and front of the holder fit into the rims (6) around the tube.
- e. Close the holder and tighten the knurled screw at the top.
- f. Connect the microphone cable to audio connector (3) (mic) on the right side of the camera.
- g. Place the microphone cable into the top clip at the front of the camera and into clip (4) at the side of the camera. (Pull and twist clip (4) to open it.)

Other microphones with a diameter of 21mm can also be used, however, ensure that the phantom power and the sensitivity of the input that match that type of microphone are correctly selected in the camera systems menu. Refer to Section 6 for more information on selecting the audio inputs and controlling the audio level.

### Note:

- When longer microphones are used, it is not necessary to place them in the split tube.
- For optimum operation, the microphone should be mounted as straight as possible.
- Don't allow the wind hood to touch the holder (7) as this reduces the damping effect.
- By placing the split facing upwards, the microphone cable does not touch the holder thus avoiding mechanical pick-up.
- The microphone can also be connected to the rear of the Triax adapter where a switch selects the input. Refer to Section 4 for more information on connecting the microphone to the rear connector.

## Tripod Adapter Plate

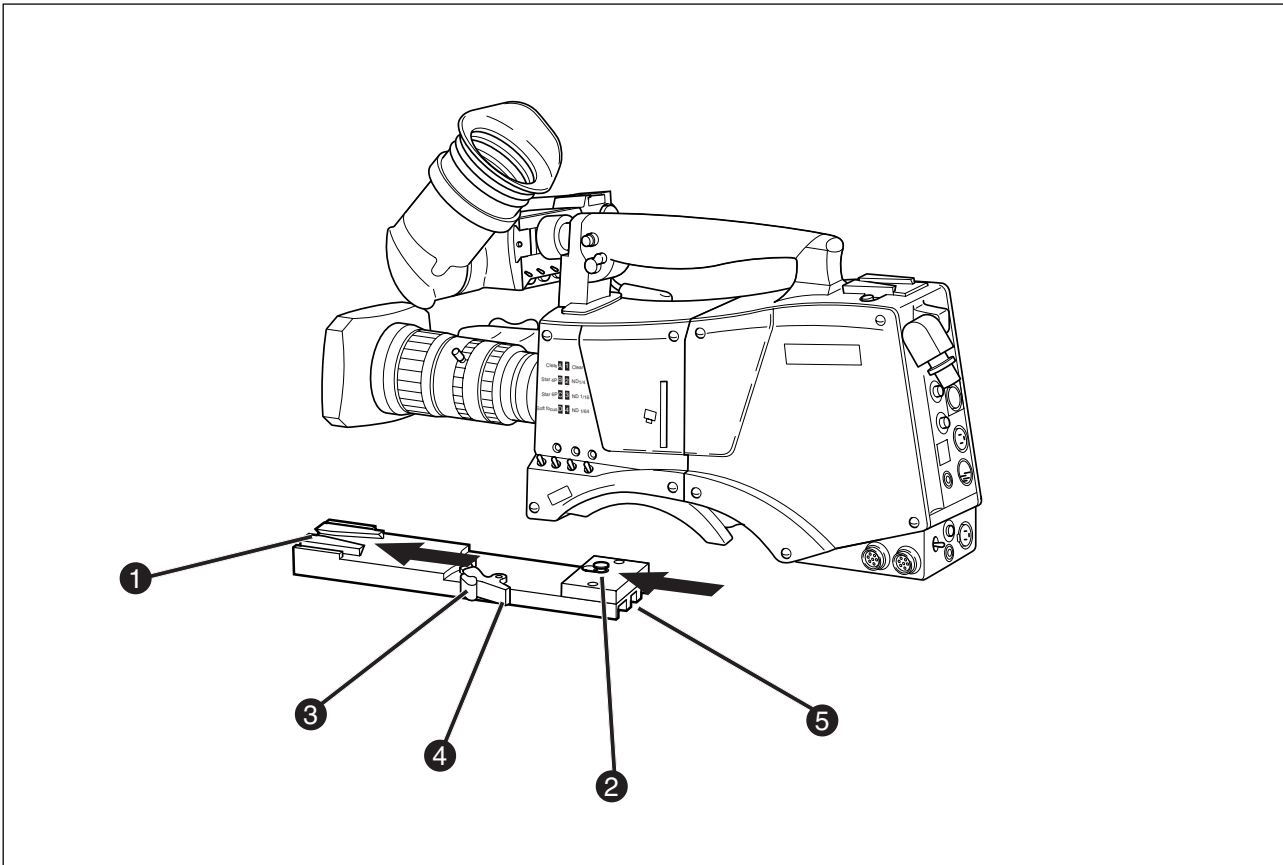

To mount the camera on a tripod, the tripod plate (LDK 5031/00 is delivered as standard) must first be attached to the tripod.

Follow the tripod manufacturer's instructions to mount the wedge plate supplied with the tripod and the tripod adapter plate firmly onto the tripod.

To attach the camera to the tripod adapter plate proceed as follows:

- Slide the camera horizontally along the tripod adapter plate from back to front ensuring that the front of the camera engages the V-slot (1) at the front of the tripod adapter plate, and that the slot on the bottom of the camera engages the stud (2) at the rear of the tripod adapter plate.
- Firmly push the camera forward until it clicks into place.

### CAUTION

Failure to attach the camera to the tripod adapter plate in the correct manner could result in an unsecured camera. Ensure that the rear stud (2) is engaged and that the camera clicks into place.

To remove the camera from the tripod proceed as follows:

- Press the red locking lever (3) against release handle (4) on the tripod adapter plate and hold.
- Ensure that you have a firm hold of the camera.
- Pull the release handle (4) forward.
- Move the camera backwards and up. The camera is now free from the tripod adapter plate.

When the camera is mounted on the tripod tighten this locking lever (5) to ensure that the stud (2) at the rear of the plate is locked firmly in place.

When removing the camera first open the locking lever (5) to free the rear stud (2).



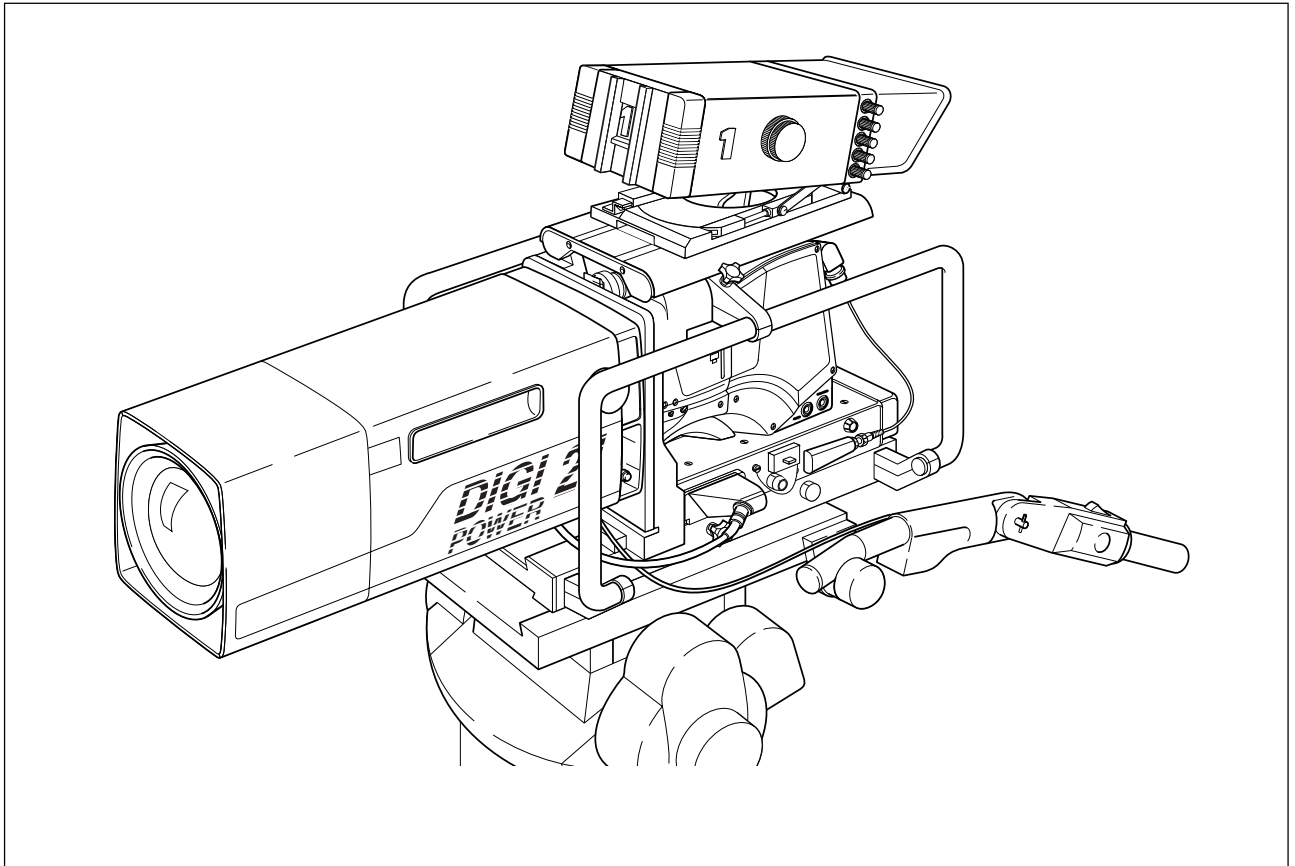

The optional SuperXPander (LDK 4482) for the LDK 5000 extends the camera's use in studio and EFP situations. This adapter allows larger studio lenses and a 7-inch viewfinder to be used with the camera. Additional facilities provided include a utility power outlet and a rear control panel.

Refer to the User's Guide of the SuperXPander for more information on mounting the camera and other units to the SuperXPander as well as information on the additional functions of the SuperXPander.

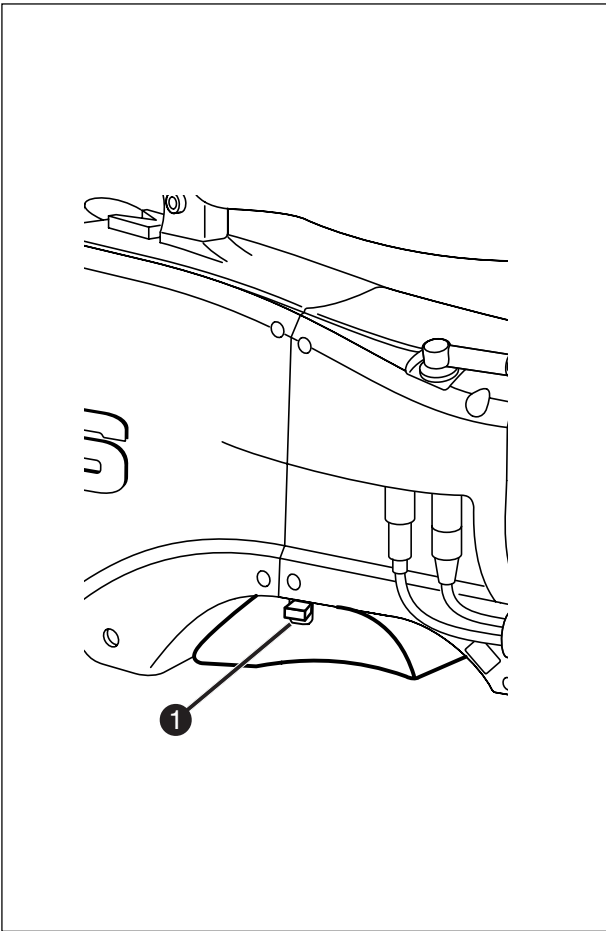

To change the position the shoulder pad press and hold lever **(1)**. The shoulder pad can now be moved backwards and forwards along the axis of the camera. Adjust the shoulder pad when all units have been mounted so that the best balanced position can be obtained.



The rain and off-use cover LDK 5021 must be used when the camera system is in a wet or damp environment. This protection is necessary for personal safety reasons. The cover can also be used indoors to protect the camera when it is used in dusty environments. It can also be useful if the camera is being put into storage. For more information on how to put on the cover refer to the User's Guide which is supplied with it.

**Note:** When the camera is used with the LDK 4482 SuperXPander the LDK 6989/00 optional rain and off-use cover is available.

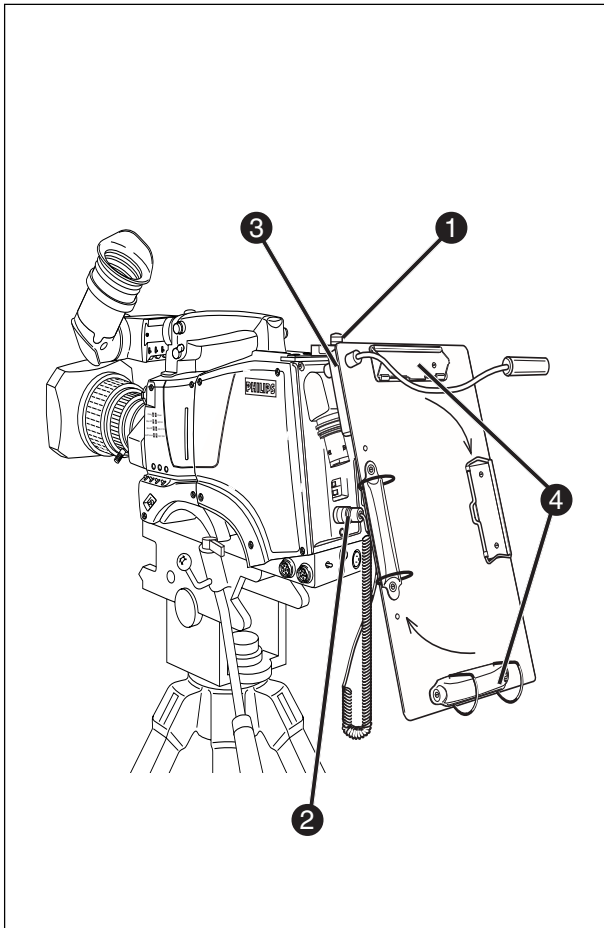

To mount the optional Script board (LDK 6985/21) onto the camera proceed as follows:

- a. Secure the Script board to the top-rear of the camera with the quick mount adapter (1).
- b. Connect Script board light cable to the script light connector (2) at the rear of the camera.

### CAUTION

Ensure that the script light does not use more than 3W of power.

The script light is switched on and off, and the intensity is varied with the knob (3) at the rear of the Script board. The retaining rings and clip (4) can be screwed onto the right or left side if required.

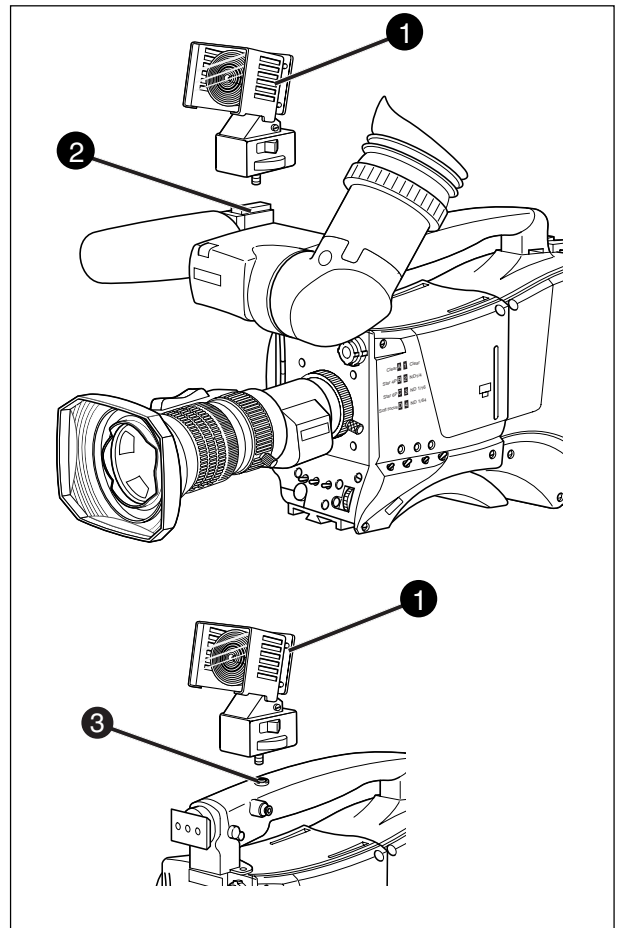

To mount a top light (1) onto the camera, proceed as follows:

- a. Screw the top light (1) into either the WW1/4"-20 screw hole (2) located on the carrying handle or the screw hole (3) on the top of the microphone holder.
- b. Power the top light according to the instructions delivered with the light.



---

# Section 3

## Configurations

*The LDK 5000 Triax is a multi-role camera and this section describes how it can be used on location or in a studio environment. Information is also provided on the main video and audio signal paths through the camera head.*

### Contents

---

LDK 5000 Configurations .....	3-2	Other Control Features .....	3-6
Single camera triax mode .....	3-3	Intercom Routing .....	3-7
Multiple camera mode .....	3-4	Audio .....	3-8
Two-wire Data Control Bus .....	3-6		

# LDK 5000 Configurations

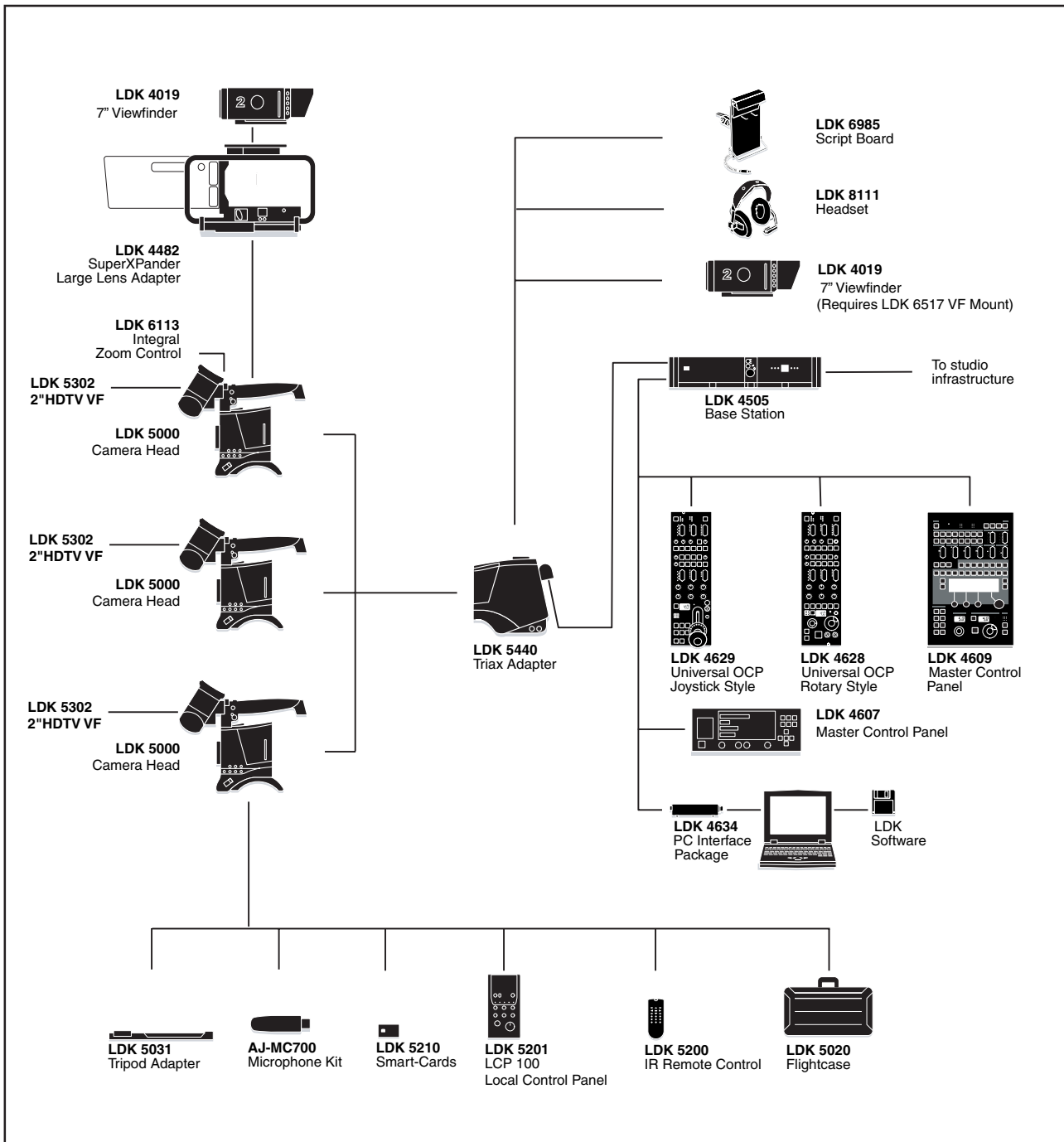

## Single camera triax mode

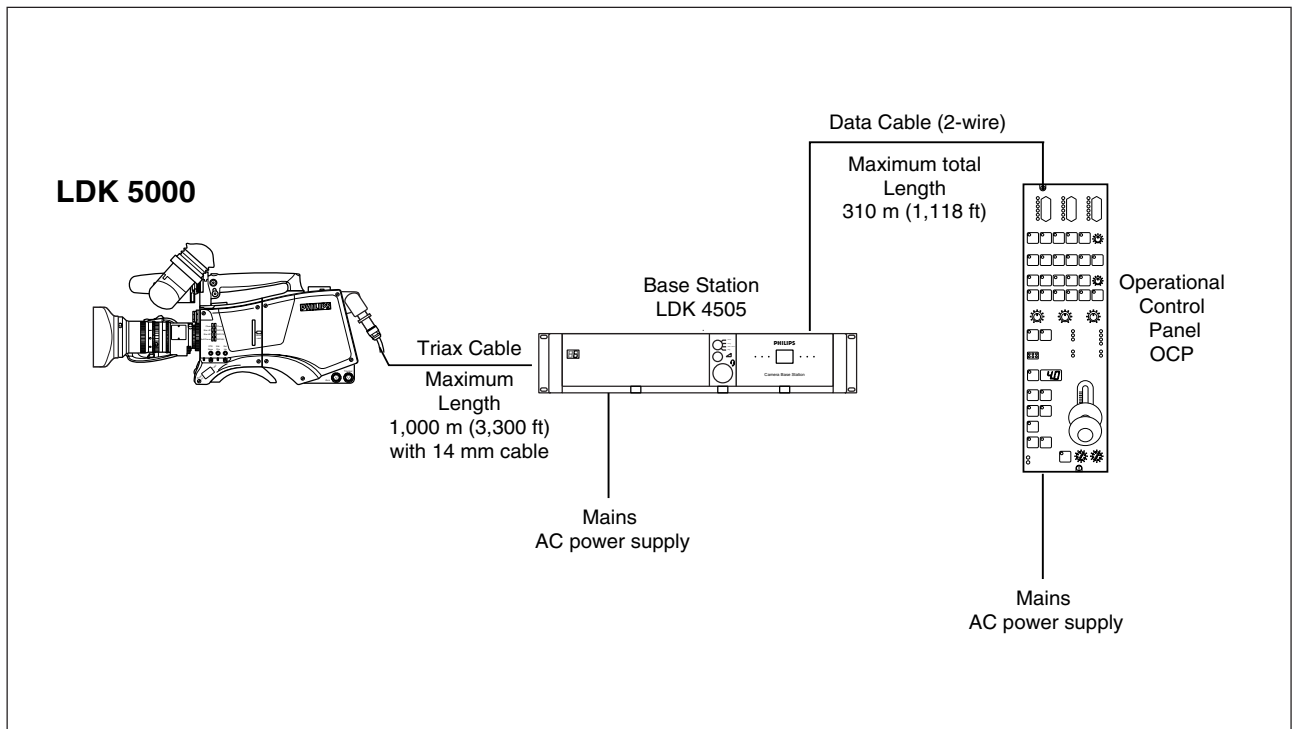

In the single camera Triax (Remote) configuration the camera is connected to a CPU via a Triax cable which can have a maximum length of 1,000 m (3,300 ft.) with 14mm cable. The Base Station provides the power supply for the camera via the Triax cable. The Base Station receives its power from the AC mains supply. The Triax cable carries Y, R-Y, and B-Y video signals, two audio signals and intercom signals from the camera head to the Base Station. It also carries external video signals and intercom signals from the Base Station to the camera.

When used in the Triax mode, remote control of the camera is achieved by a remote control panel of the Series 9000 Control System. This can be an operational control panel (OCP) connected to the Base Station. The data communication between camera and Base Station is carried over the Triax cable.

# Multiple camera mode

## LDK 5000

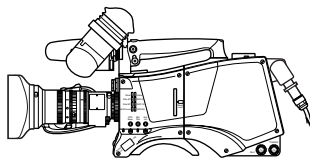

Triax Cable  
Maximum Length  
1,000 m (3,300 ft)  
with 14 mm cable

Base Station  
LDK 4505

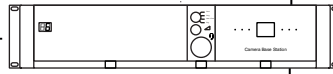

## LDK 5000 with LDK 4482 SuperXPander

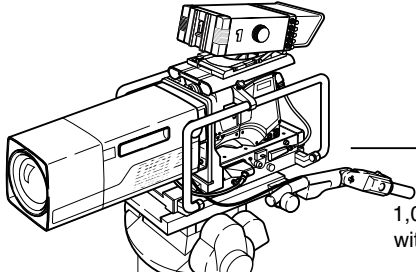

Triax Cable  
Maximum Length  
1,000 m (3,300 ft)  
with 14 mm cable

Base Station  
LDK 4505

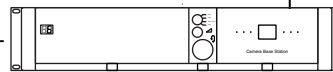

## LDK 200

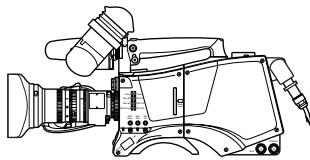

Triax Cable  
Maximum Length  
2,400 m (7,875 ft)  
with 14 mm cable

Base Station  
LDK 4501

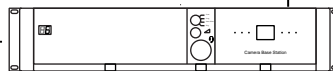

## LDK 23HS mkII (with LDK 4482 SuperXPander)

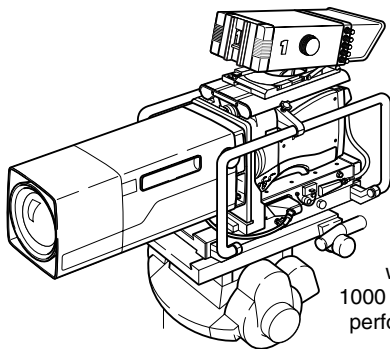

Triax Cable  
Maximum Length  
800 m (2,625 ft)  
with 14 mm cable  
1000 m (3281 ft) with minor  
performance degradation

CPU  
LDK 4058 mkII

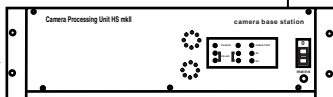

## LDK 20

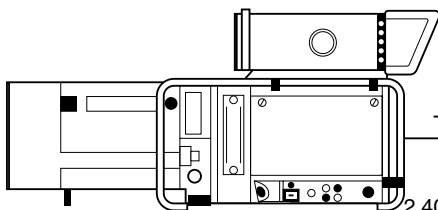

Triax Cable  
Maximum Length  
2,400 m (7,875 ft)  
with 14 mm cable

Base Station  
LDK 4501

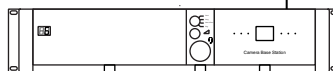

Data Cable  
(2-wire)

Data Cable  
(2-wire)

Data Cable  
(2-wire)

Data Cable  
(2-wire)



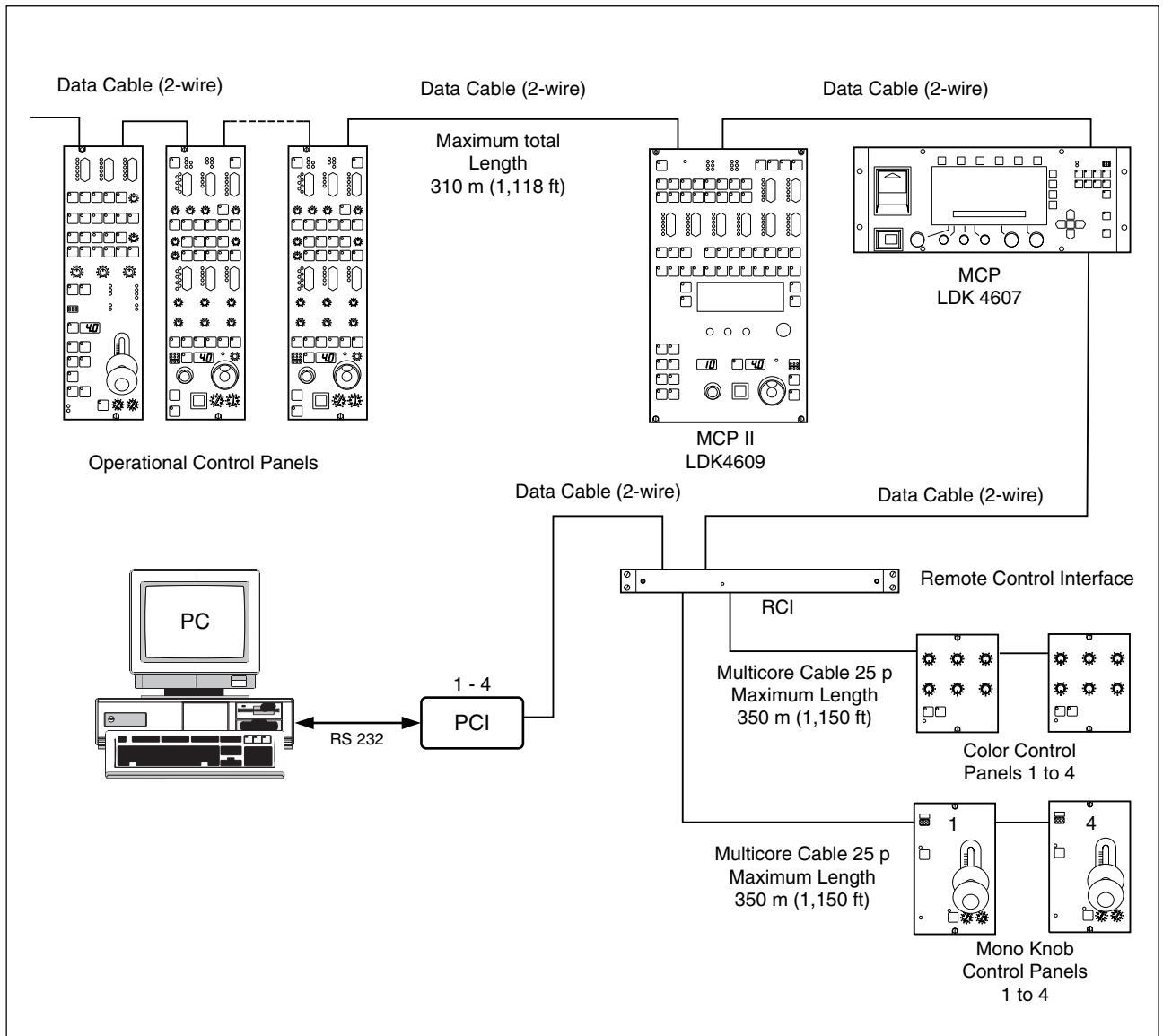

This configuration is the multiple camera Triax mode. The camera is connected to a CPU as in the single camera Triax mode. The data bus is looped-through from CPU to CPU's, Base Stations, OCP's and MCP. The OCP's (Operational Control Panels) are used to control the cameras and a MCP (master Control Panel) can also be connected to extend the control facilities.

**Note:** A maximum of 15 looped-through standard camera systems in one chain can be handled, however, in a multiple system the load of a LDK 23 HS (mkII) is twice the load of a standard camera.

The two-wire data bus is used to connect all control units in the Series 9000 control system. The data cable loops-through from one unit to the other. The order of connection is not important, however, the total length of the cables must not exceed 310 meters (1,118 ft).

Each unit connected directly to the data bus, either Base station, camera head or OCP, is identified by a number. In order to ensure, for example, that OCP 1 controls the camera connected to Base station 1, the same unique number must be assigned to both OCP 1 and Base station 1. The assignment number is set internally on the units during installation.

The assignment number of a camera head connected to a Base station is automatically set to the number of the Base station to which it is connected. The number on the Base station, which is connected to the data bus, must be set to the number of the assigned control panel.

It is important to set a unique number for each Base station/OCP group as unpredictable control situations could arise otherwise.

The MCP is also connected to the data bus, however, it is not necessary to set an internal assignment number. The camera or cameras to be controlled are selected on the MCP front panel itself when operating the unit.

### **Note**

A maximum of 15 looped-through standard camera systems in one chain can be handled, however, in a multiple system the load of a LDK 23 HS (mkII) is twice the load of a standard camera.

### **Private Data**

A private data channel is also available between the camera and the Base station. This is a two-way serial channel operating at 2400 B/s with TTL level. This channel can be used for digital data links. For detailed information refer to the Base station's User's Guide.

### **Analogue Ch0-Ch1**

Two analogue control channels are available from the Base station to the camera. These provide a control voltage from 0V to +5V that can be used for pan control for example. For more information on these channels refer to the Base station's User's Guide.

**Note:** If the analogue Ch1 is used to externally switch the Aspect Ratio, Ch 1 is not available for analogue signals from the Base station to the camera.

## Intercom Routing

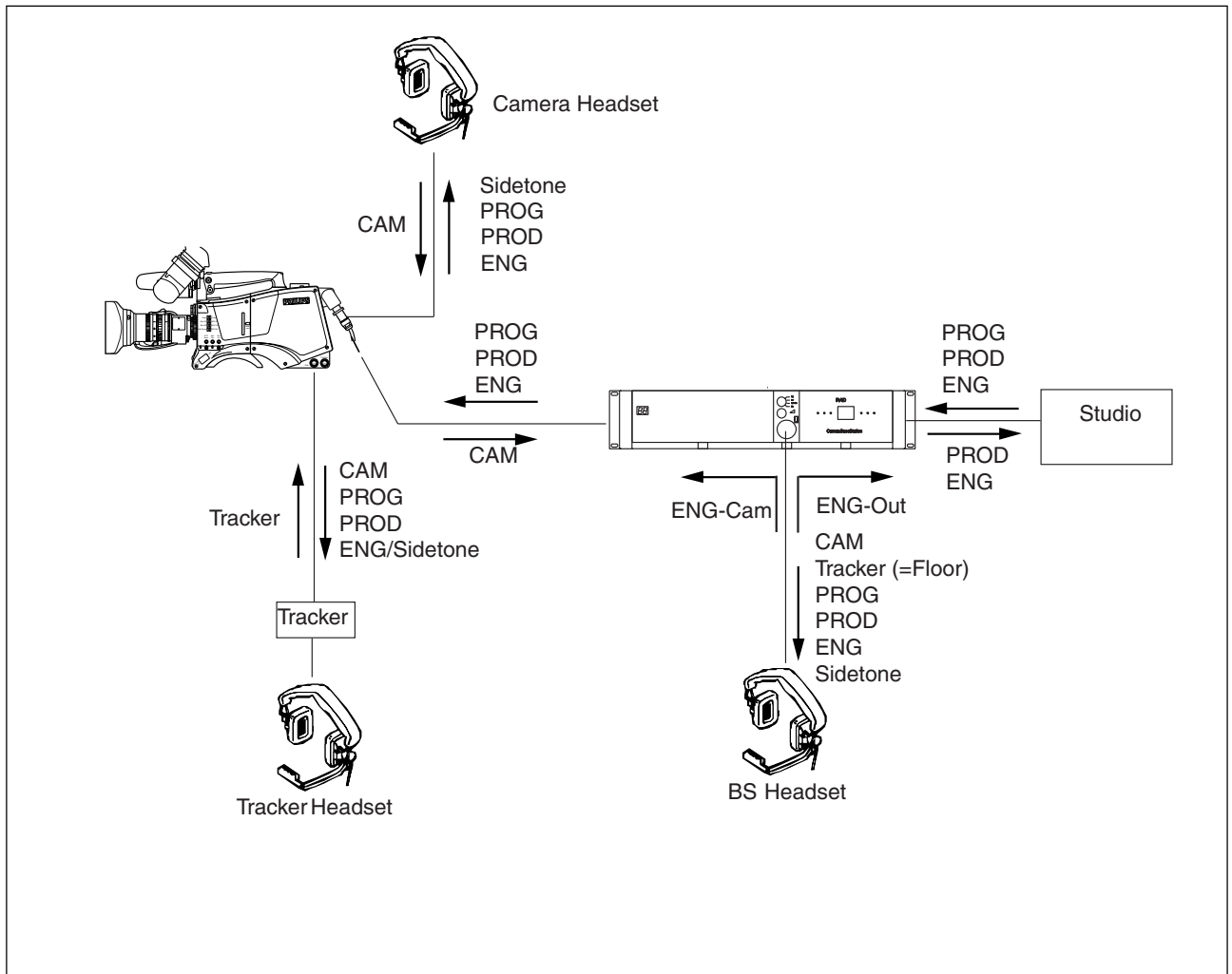

Two intercom headsets can be connected to the LDK 5440 Triax adapter; one for the cameraman and one for the tracker.

There are three intercom channels from the Base station to the camera. These carry the production, engineering and the programme intercom signals. Two intercom channels from the camera to the Base station carry the tracker and camera intercom microphone signals. The camera intercom microphone signal can be routed to engineering to production via the intercom routing switch on the back panel of the adapter.

The tracker headphones receives the camera microphone,

production and programme intercom signals and if selected in the systems menu the tracker microphone sidetone or engineering intercom signal.

The engineering, production and programme intercom signal from the Base station, the tracker microphone and the camera microphone sidetone are all available for the camera headset. The volume of these signals can be adjusted and switched to either the right or left side of the headset.

## Audio

---

The back panel of the LDK 5440 Triax adapter has two connectors for audio microphones. The signals applied to these connectors are amplified and passed to the multiplexer/transmitter section of the camera which sends them to the Base station via the Triax cable. The amplification factor of the audio microphone signals can be selected via the systems menu, the Base station or the Master Control Panel.

Phantom power is available for the audio microphones. The default value is +48V (refer to Section 4 "Audio" for information on changing this value).

---

## Section 4

### Location of Controls and Functions

*This section shows the physical location of the controls and connectors on the camera. These are grouped according to their function so as to provide a quick reference guide to the operation of a particular aspect of the camera. The controls and connectors are shown for both the camera head and the Triax adapter.*

---

#### Contents

Power Supply .....	4-2	Viewfinder Indicators .....	4-8
Security and Access .....	4-3	Audio .....	4-9
Video Output .....	4-3	Intercom .....	4-10
Video Functions .....	4-4	Control Functions .....	4-11
Monitoring Functions .....	4-6	Auxiliary Functions .....	4-12
Viewfinder .....	4-7		

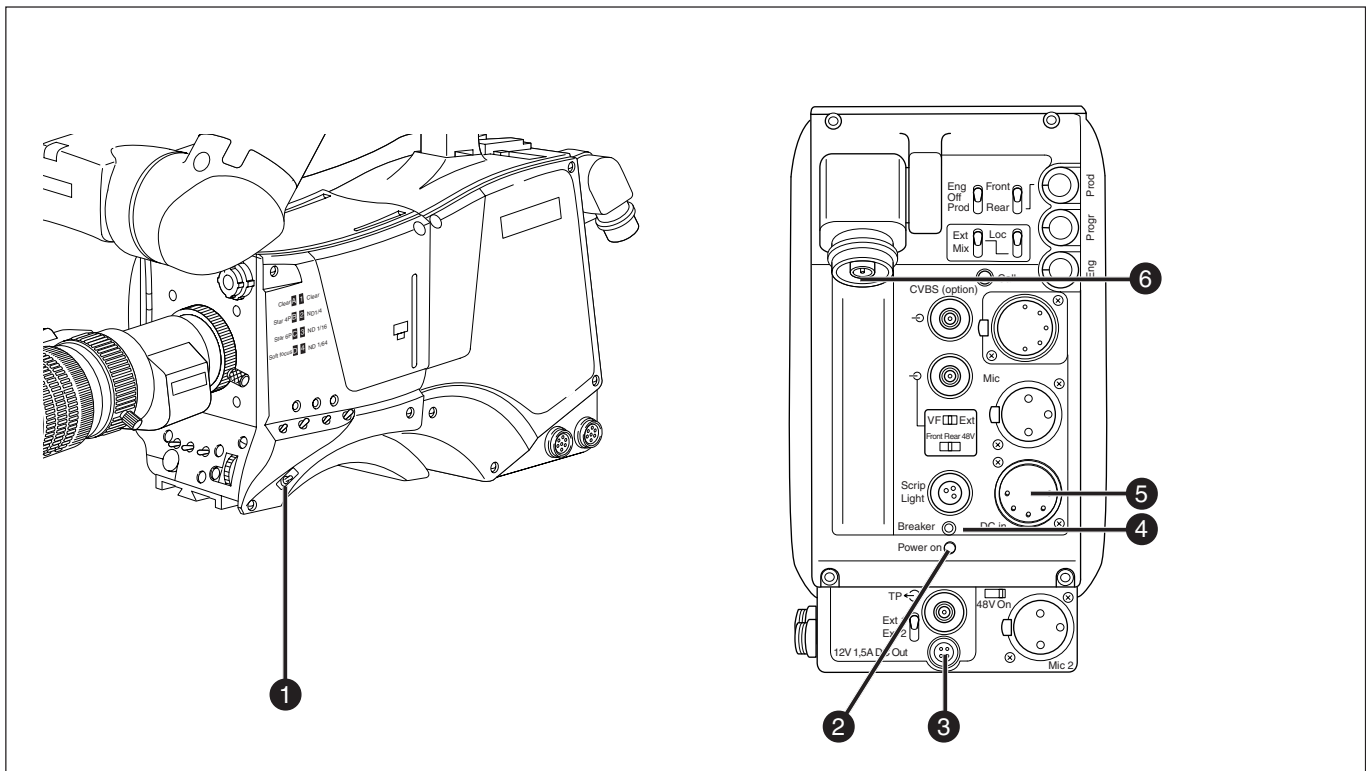

## 1 Power switch

The power switch has two positions:

- On : Power to camera is switched on.
- Off : Power to camera is switched off.

When you switch off the power, the access rights that were obtained by the use of the PIN code are disabled and the camera starts at the assigned user level when switched on again.

## 2 Power on indicator

The power on indicator lights when power is supplied to the camera and the camera power switch is on.

## 3 DC and Tally output socket

This socket supplies +12Vdc ( $\pm 0.25V$ ) when the camera is in the Triax mode (maximum current 1.5A). The socket also provides access to an internal tally switch. When the camera is on-air the contact of the internal relay is closed.

## 4 Circuit breaker button (BREAKER)

If excessive current flows in the camera the circuit breaker trips and shuts off power to all the units. If this happens check the units for faults and if necessary take corrective action before pressing the circuit breaker button to reset the power.

## 5 DC input socket

This socket accepts a DC supply voltage of 12V Nominal (11V to 17V) for powering the camera in stand-alone mode for service purposes. Maximum power consumption 23W.

### CAUTION

▶ The input voltage must not exceed 17 Vdc.

## 6 Triax cable socket

The triax cable is connected to this socket. The power supply for the camera is normally supplied from the Base Station via the triax cable.

The triax cable also carries all the video, audio/intercom and control signals between the camera and the Base Station.

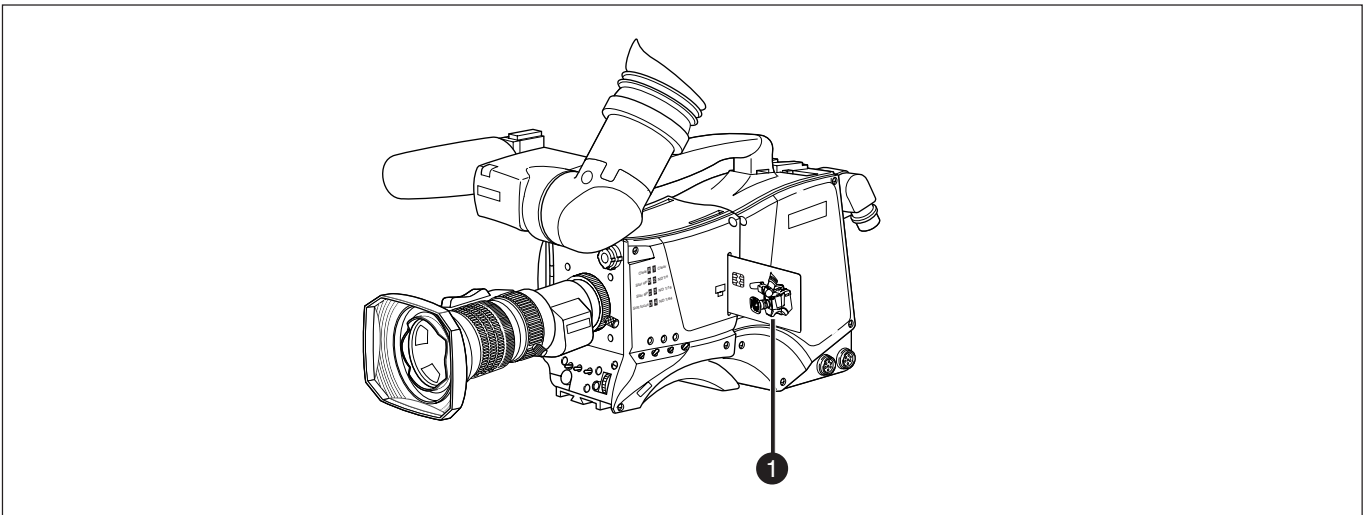

### 1 Smart card slot

Insert your smart card into this slot with the chip on the card facing the front of the camera. Push the card home until it fits snugly.

There are two types of card; an owner card and a user card. Both cards store operator files and scene files.

The owner card can be used to change the user level of the camera. The user level determines which set of controls and functions can be changed by the camera operator. Refer to Section 6 for more information on the smart card.

A smart card is not required for normal operation of the camera.

**Note:** Only use an original camera card.  
Store the owner card in a safe place.

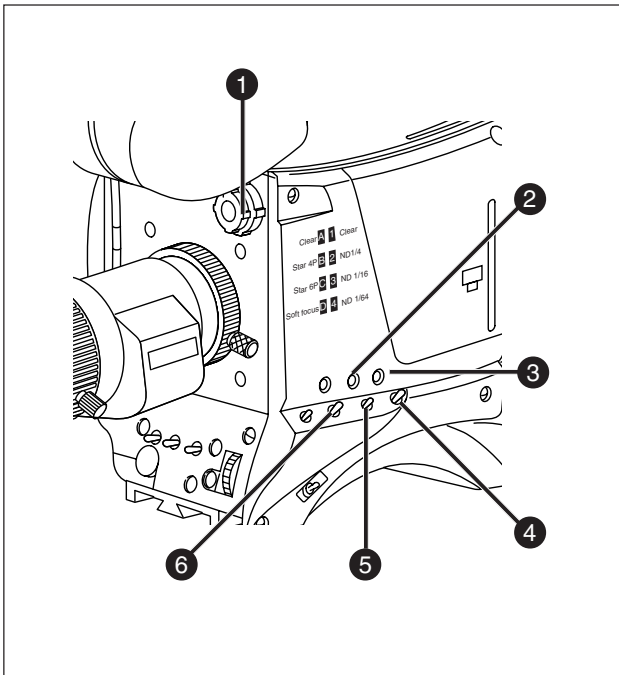

## 1 Filter switches

Rotate these two switches to move the optical filter wheels.

The outer (bigger) filter switch has four positions:

- 1 : Clear
- 2 : ND 1/4 filter ( 2 stops)
- 3 : ND 1/16 filter ( 4 stops)
- 4 : ND 1/64 filter ( 6 stops)

The inner (smaller) filter switch has four positions:

- 1 : Clear
- 2 : 4-point star
- 3 : 6-point star
- 4 : Soft focus

The status of the filter wheels is displayed in the viewfinder for a few seconds.

The ND/RE indicator in the 2-inch viewfinder lights when an ND (Neutral Density) filter is selected.

**Note:** No optical colour filters are needed with this camera as the colour balance range is sufficient to measure temperatures from 2.5K to 20K.

## 2 Extended Iris button

When this button is pressed once the current value of the automatic extended iris function. Press the button twice in quick succession to switch between on and off.

This function automatically regulates the video signal level by adjusting the iris opening, the gain level and the exposure time to suit the ambient lighting conditions. When extended iris is on, the non-standard indicator (!) in the 2-inch viewfinder lights, and gain and exposure controls are blocked.

## 3 Std Scene File button

The standard scene file button is a momentary button which, when pressed for two seconds, recalls the standard scene file video values. These values do not take effect immediately if the camera is on air; they take effect when the camera goes off air.

Refer to the Appendix for the default values of the factory defined standard scene file. Refer to Section 6 to find out how to define and assign a standard customer scene file.

## 4 Black Stretch switch

This switch when set to the On position, starts the black stretch function. This function gives more detail in the dark areas of the picture. Set the switch to Off to switch off the function. When black stretch is switched on the non-standard indicator (!) in the viewfinder lights.

## 5 Colour Temp. switch (White Bal.)

This up/down scroll selection switch allows a choice between three preset colour temperatures:

- 3200K (3.2K) - for studio lighting conditions
- 5600K (5.6K) - for outdoors, clouded conditions
- 7500K (7.5K) - for outdoors, clear blue skies

three memory positions:

- FL- memory position for fluorescent light
- AW1 - memory position 1
- AW2 - memory position 2

and an automatic continuous white position:

- AWC - continuous measurement (2.5K to 20K)

The memory positions can be filled with measured values using the automatic white balance switch at the front. Indicators in the 2-inch viewfinder light to show which position is selected. None of these indicators light when AWC is selected, but the non-standard indicator (!) lights.

## 6 Colour Bars switch (Bars)

The Bars switch turns the colour bar test signal on and off. The lens iris closes automatically when the colour bars are switched on.



## Video Functions

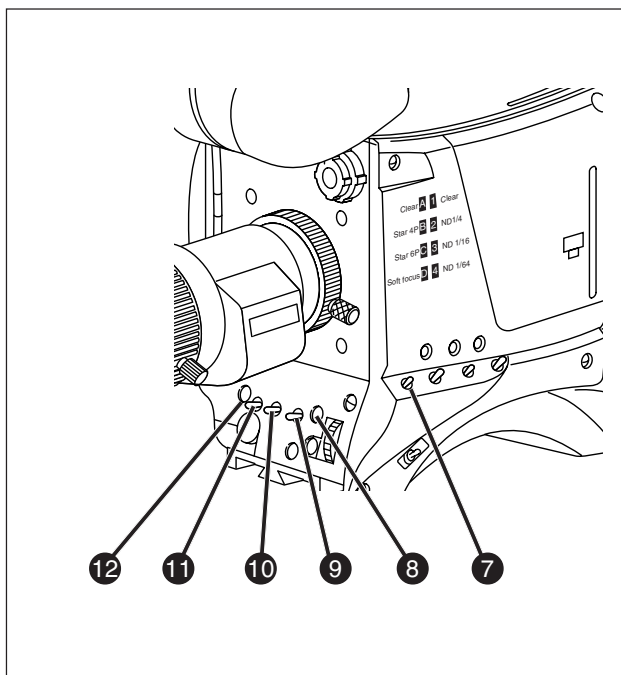

### 7 Gain selection switch

This up/down scroll selection switch gives a choice of five master gain settings. The values for these settings, except 0 dB, can be set in the Install menu of the camera systems menu (refer to Section 6). The indicators in the 2-inch viewfinder light as follows:

-	Gain is - (-3, -6dB)
+	Gain is + (+3, +6, +9dB)
++	Gain is ++ (+6, +9, +12dB)
+ and ++	Gain is +++ (+12dB)

**Note:** Reduce crispness (peaking) in the viewfinder when using the +++ position.

### 8 Clean Scan button

When shooting computer monitors with higher frame frequencies than the camera use the Clean Scan function to avoid horizontal bars in the picture.

Press the Clean Scan button for two seconds to directly access the variable exposure (clean scan) function. Use the rotary control to change the value and so remove the noise bar. When you are finished shooting the monitor press the Clean Scan button for two seconds to switch off the Clean Scan function.

When the Clean Scan function is on, the non-standard indicator in the viewfinder lights. Refer to Section 5 for more information on shooting screens.

### 9 White Balance switch

This momentary switch is used to start the automatic white balance process. The camera, when pointed at a white area in the centre of the picture, measures and stores a colour temperature setting in the FL, AW1 or AW2 memory position.

The white balance switch only operates if the colour temperature is set to the FL, AW1 or AW2 position. Refer to Section 5 for more information on how to use the automatic white balance.

**Note:**

Black balance is not necessary with this camera because of the continuous automatic black control circuits.

### 10 Exposure Time switch

This up/down momentary switch gives a choice of eight exposure time settings. These are:

Nom.	- nominal setting
Var.	- enables the exposure to be varied
Crt	- for shooting sync-locked monitors
Film	- enables the exposure to be varied with running shutter.
1/200	- for fast moving objects
1/500	- for fast moving objects
1/1000	- for fast moving objects
50 Hz	- shooting with 50Hz lighting (adjustable)
60 Hz	- shooting with 60Hz lighting (adjustable)

If an exposure time other than nominal is selected, the non-standard indicator (!) in the viewfinder lights.

### 11 Vertical Shift switch (V-Shift)

Sometimes when shooting TV screens or monitors with the same display frequency as the camera, a horizontal black bar is seen in the viewfinder because the camera is blanking while the TV is not.

The V-Shift switch shifts the camera blanking. It is spring-loaded with a central rest position. Holding the switch in the + or - position moves the bar up or down so that it is no longer visible in the viewfinder. This function is only available when the camera is used in the stand-alone mode and is not active when the camera is genlocked or on-air.

### 12 VTR Start button

In the triax mode this button switches the intercom microphone of the headset to the production intercom channel.

This button operates in parallel with the VTR button on the lens.

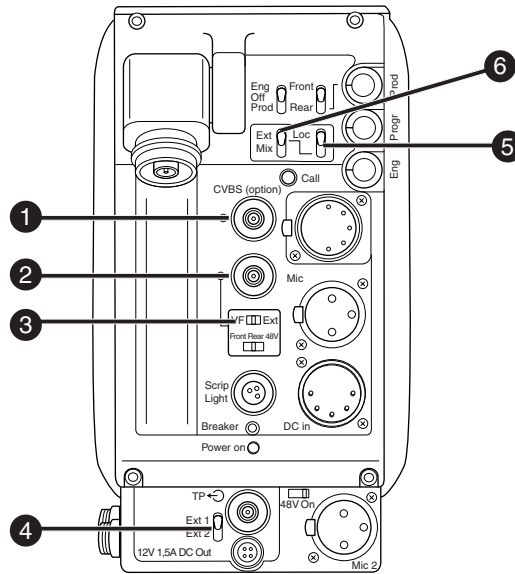

**1 CVBS output connector**

This BNC connector provides a 1Vpp CVBS viewing output signal with the same frame frequency.

**2 Viewfinder / External video output connector**

This BNC connector carries the viewfinder signal or the external video signal from the Base Station depending on the position of switch (3).

**3 Video output selection switch**

This switch determines whether the viewfinder signal from the camera or the external video signal from the Base Station is available at connector (2).

**4 External signal selection switch**

This switch selects either the EXT1 or EXT 2 signal for display in the viewfinder when the viewfinder signal selection switch (6) is in the EXT position.

**5 Viewfinder selection switch**

This switch is used to select the camera Y signal or an external signal - set with (6) - for display in the viewfinder. The Ret. button on the lens also selects this signal in parallel with this switch.

**6 External signal selection switch**

This switch selects the signal displayed in the viewfinder when the viewfinder signal selection switch (5) is in the EXT position. The signal displayed is as follows:

- EXT : Base Station external input 1.
- MIX : Base Station external input 1 and camera Y signal mixed.

**Note:** Switches (5) and (6) are disabled when the SuperXPander is used.

## Viewfinder

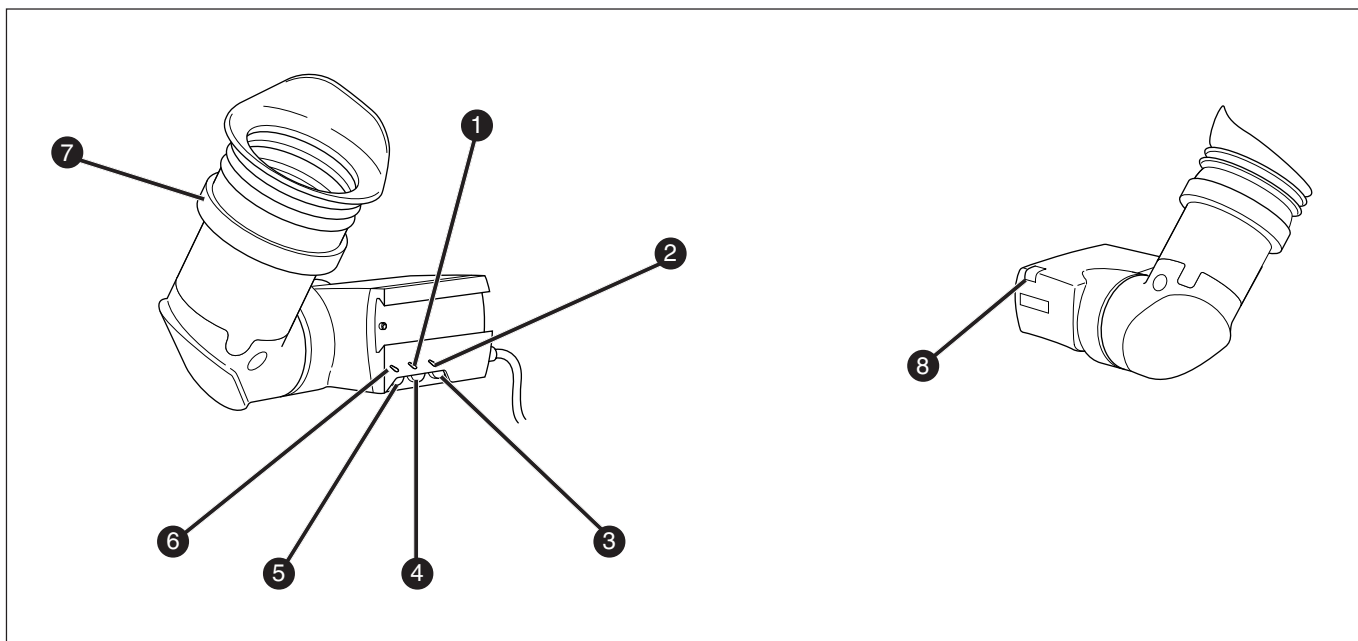

### 1 Zebra switch

This switch disables (OFF position) or enables the zebra pattern in the viewfinder which indicates high video levels. Values for the zebra function are selected in the VF menu. (The zebra pattern is switched off when the skin view is on.)

### 2 Option switch

This switch is included on the viewfinder to allow future features to be incorporated.

### 3 Brightness control

Use this rotary control to adjust the brightness of the viewfinder display to suit your needs.

### 4 Contrast control

Use this rotary control to adjust the contrast of the viewfinder display to suit your needs.

### 5 Crispening control

This rotary control adjusts the sharpness of the picture displayed in the viewfinder. Reduce the crispening for a better picture when the gain is set to +++.

### 6 Tally switch

The tally switch is used to control the tally indicator at the front of the viewfinder.

When this switch is set to the ON position, the tally indicator light when the camera is on-air.

When this switch is set to the OFF position, the tally indicator does not light when the camera is on-air.

The tally switch does not control the tally indicator at the rear of the carrying handle.

### 7 Dioptre

The dioptre of the viewfinder can be adjusted to suit your eyesight by turning the dioptre ring. The range of the dioptre is +1 to -3.

### 8 Tally indicators (red)

The red tally indicators at the front of the viewfinder and at the rear of the carrying handle light to indicate that the camera is on-air. The tally indicator at the front of the viewfinder does not light when the camera is on-air if the tally switch is set to the OFF position.

## Viewfinder Indicators

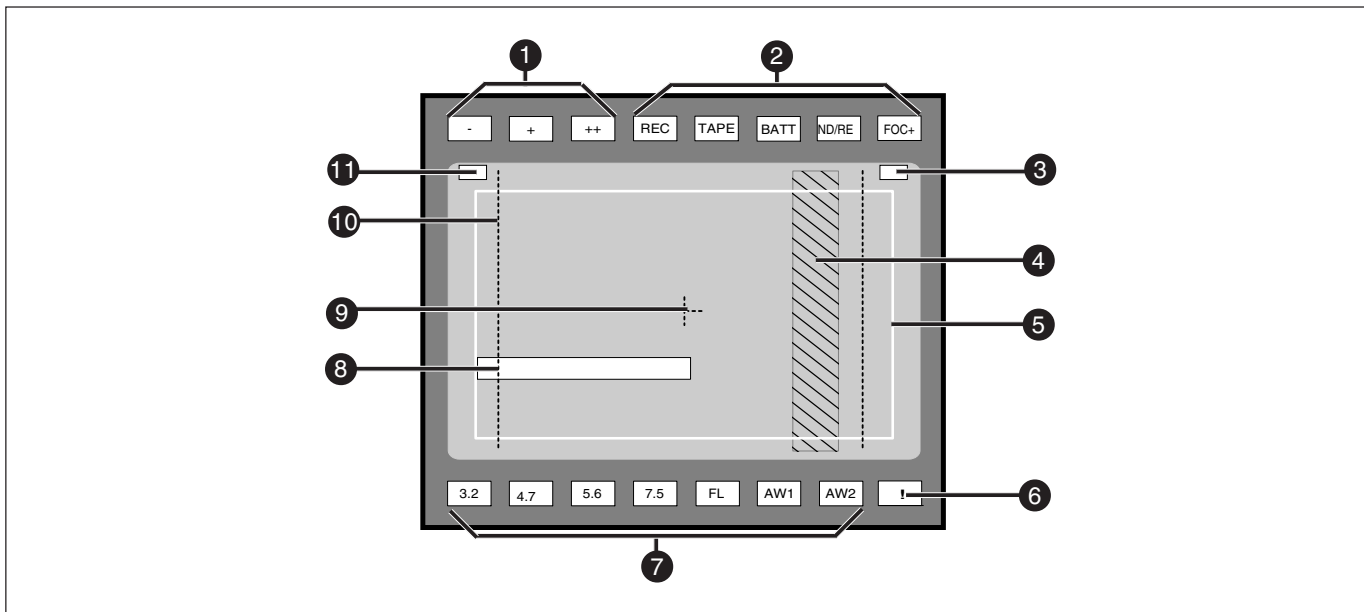

### 1 Gain indicators

The gain indicators in the viewfinder light as follows:

- Gain is - (-3, -6dB)
- + Gain is + (+3, +6, +9dB)
- ++ Gain is ++ (+6, +9, +12dB)
- + and ++ Gain is +++ (+12dB)

### 2 Top indicators

- REC** lights when the camera is on-air.
- TAPE** lights when the studio ISO signal is received.
- BATT** lights if the supply voltage is less than 11V.
- ND/RE** lights when an ND optical filter or the lens range extender is selected.
- FOC+** lights when the focus assist function is on.

### 3 Iris indication

Indicates the value of the iris opening (when enabled in the VF menu).

### 4 Zebra pattern

This diagonal line pattern warns the operator that the area affected has risen above a predetermined level of the full scale video exposure value. Level and contrast are selected in the VF menu.

### 5 Safe area marker

The safe area marker indicates an area that represents 80% of the whole viewfinder picture area. This is the minimum area seen on a TV-set.

### 6 Non standard indicator

The non-standard video settings indicator (!) lights when exposure is not set to nominal. It also lights when black stretch or extended iris is on and if AWC or FL is selected with the Colour Temperature selector.

### 7 White Balance indicators

The white balance indicators light as follows:

- 3,2** - preset temperature of 3200K is selected
- 4,7** - preset temperature of 4700K is selected
- 5,6** - preset temperature of 5600K is selected
- 7,5** - preset temperature of 7500K is selected
- FL** - memory for fluorescent light is selected
- AW1** - memory 1 is selected
- AW2** - memory 2 is selected

None of these indicators light if AWC is selected.

### 8 Message box

The display time of this information message box is set by the Info time item of the VF menu.

### 9 Centre marker

This cross marks the centre of the picture.

### 10 Cadre marker

These dotted white lines or a shaded area show the limits of a 4:3 picture, or the limits of a 14:9 picture.

### 11 Zoom indication

Indicates the degree to which the lens has been zoomed in or out if this feature is supported by the lens. It shows 50 if not supported.

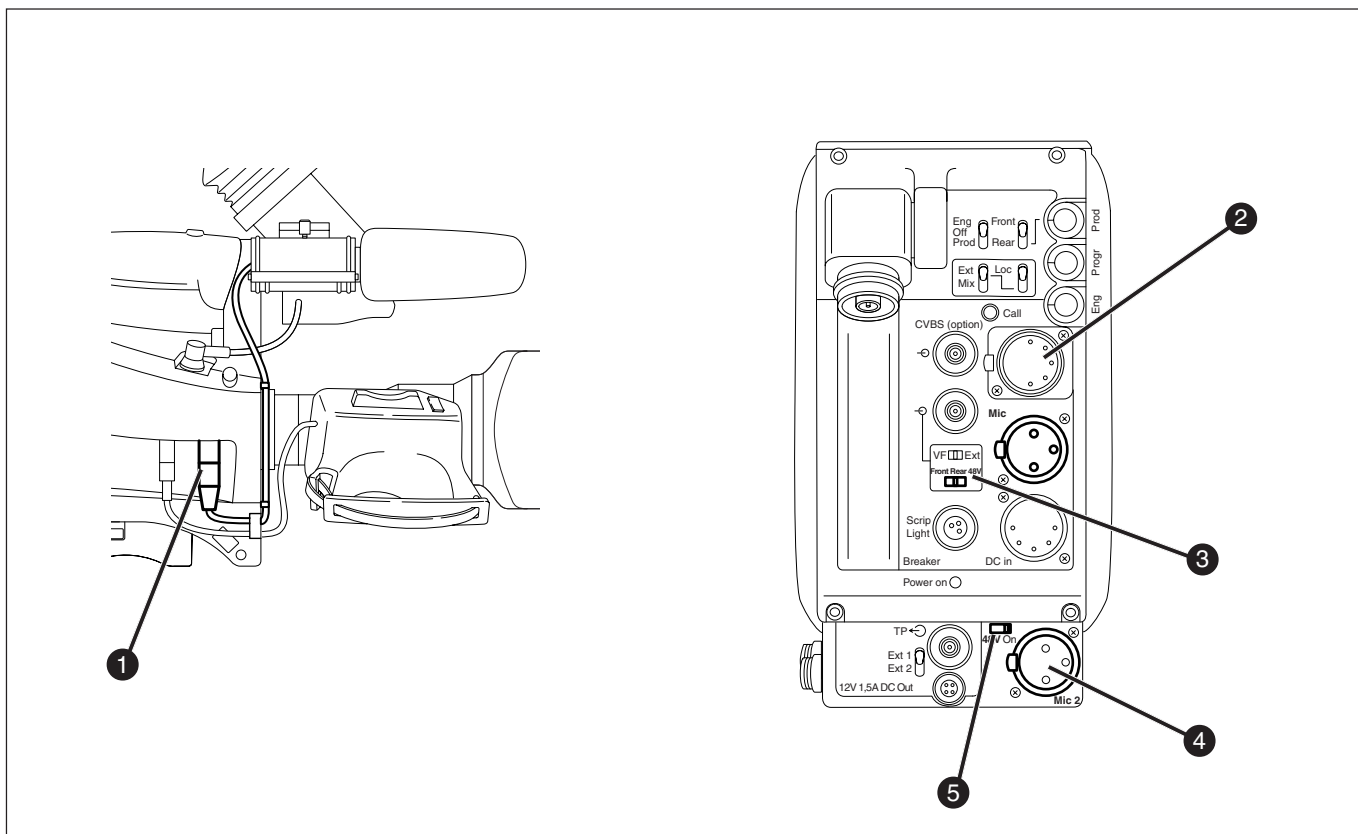

- 1 Audio microphone connector front**  
 Balanced input connector for a high quality microphone. A phantom power supply (48V) for the microphone is provided from this socket. The gain of this audio channel can also be controlled.
- 2 Audio microphone connector rear**  
 Balanced input connector for a high quality microphone.
- 3 Audio microphone switch**  
 A 3-position switch that selects the audio microphone connector at the front or the connector at the rear. The third position selects the rear connector with a phantom power supply (48V).
- 4 Audio microphone 2 connector rear**  
 Balanced input connector for a second high quality microphone.
- 5 Microphone 2 phantom power switch**  
 A 2-position switch that selects a phantom power supply (48V) for the second audio microphone.

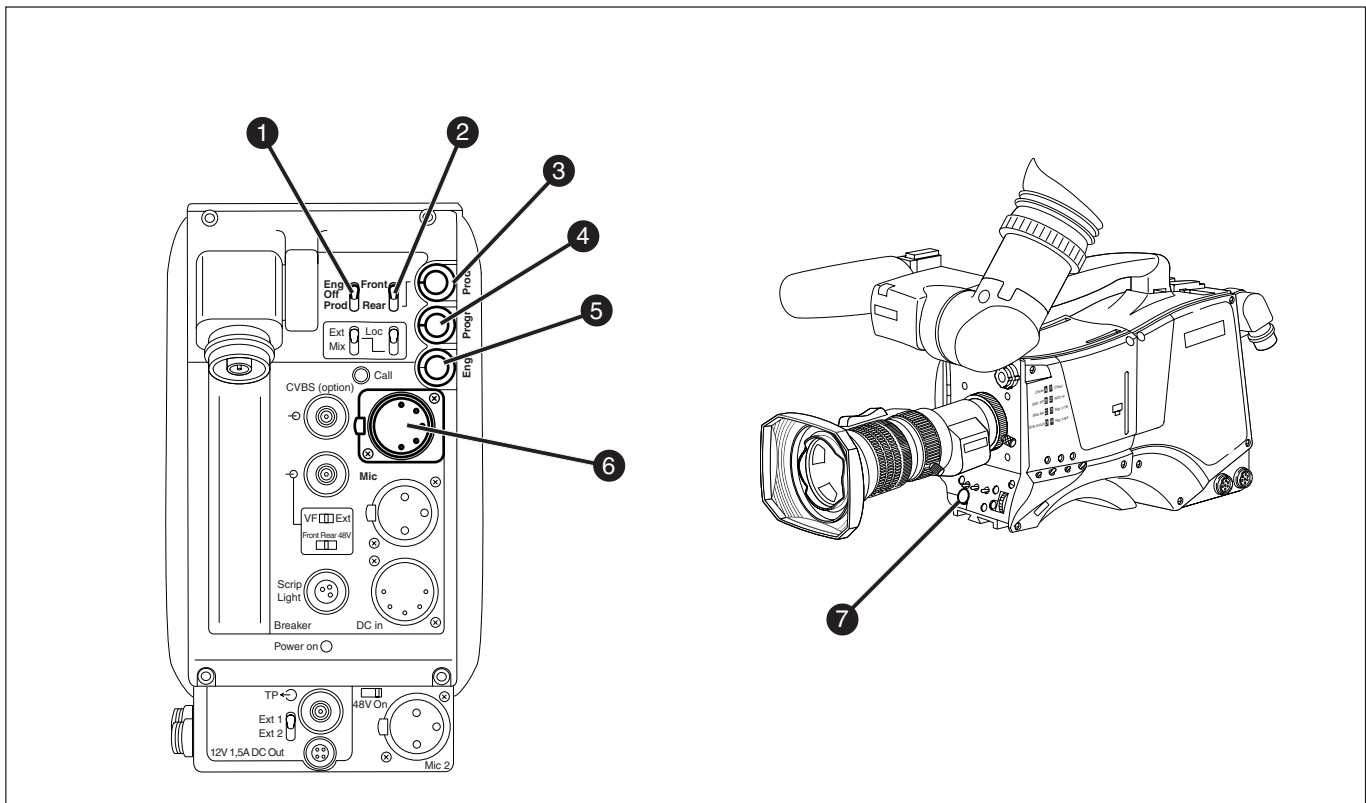

## 1 Intercom routing switch

A 3-position switch that routes the camera operator intercom microphone signal to engineering (ENG) or production (PROD), or turns off the intercom. The momentary VTR switch at the front of the camera, or on the lens can be used to route the cameraman's intercom microphone signal to production, regardless of the position of this switch.

## 2 Headset Production vol. control selection

A 2-position switch for the production intercom which selects control of the volume at the front of the camera (7) or control of the volume at the rear (3).

## 3 Headset Production volume control

This control varies the volume of the production intercom signal to the camera operator's headset when the selection switch (2) is in the REAR position.

## 4 Headset Programme volume control

This control varies the volume of the programme intercom signal to the cameraman's headset.

## 5 Headset Engineering volume control

This control varies the volume of the engineering intercom signal to the cameraman's headset.

## 6 Cameraman intercom connector

Headsets with dynamic or electret type microphones can be connected to this socket.

## 7 Headset Production volume control

This control varies the volume of the production intercom signal to the camera operator's headset when the selection switch (2) is in the FRONT position.

## Control Functions

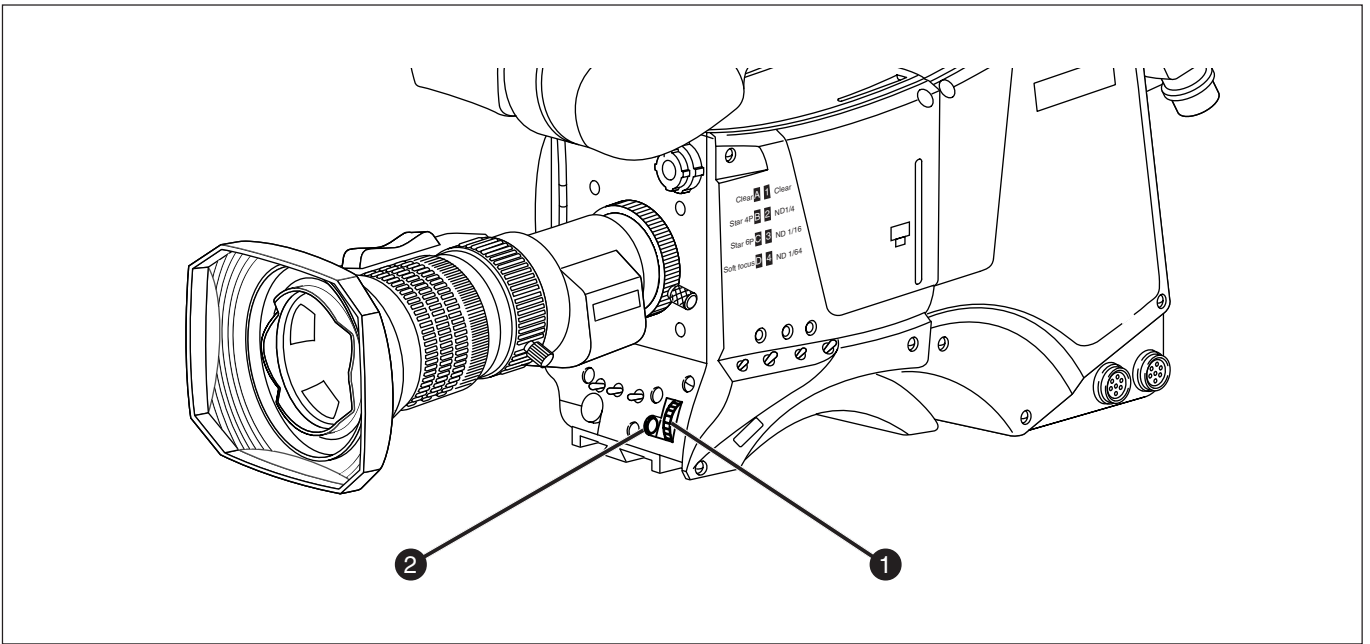

The system menus are displayed in the viewfinder. There are two controls at the front of the camera that allow you to navigate through these menus.

The functions handled by the system menus are divided into eight different menus that are listed in the main menu as follows:

<b>VF</b>	>>
<b>Lens</b>	>>
<b>Video</b>	>>
<b>Install</b>	>>
<b>Files</b>	>>
<b>Security</b>	>>
<b>Diagnostics</b>	>>
<b>Service</b>	>>

(Some of these items may not appear if the user level is not set to 3.)

Each of these menus gives you access to a particular group of functions.

### 1 System Menu Rotary control

This rotary control is used to move through the various menus of the control system. It is also used to vary the value of some functions.

### 2 System Menu Select switch

This switch, when pressed, selects the particular menu that is pointed out by the cursor in the viewfinder menu display. It is also used to set an on/off function or to select a value from a list.

More information on using the system menus is contained in Section 6.

## Auxiliary Functions

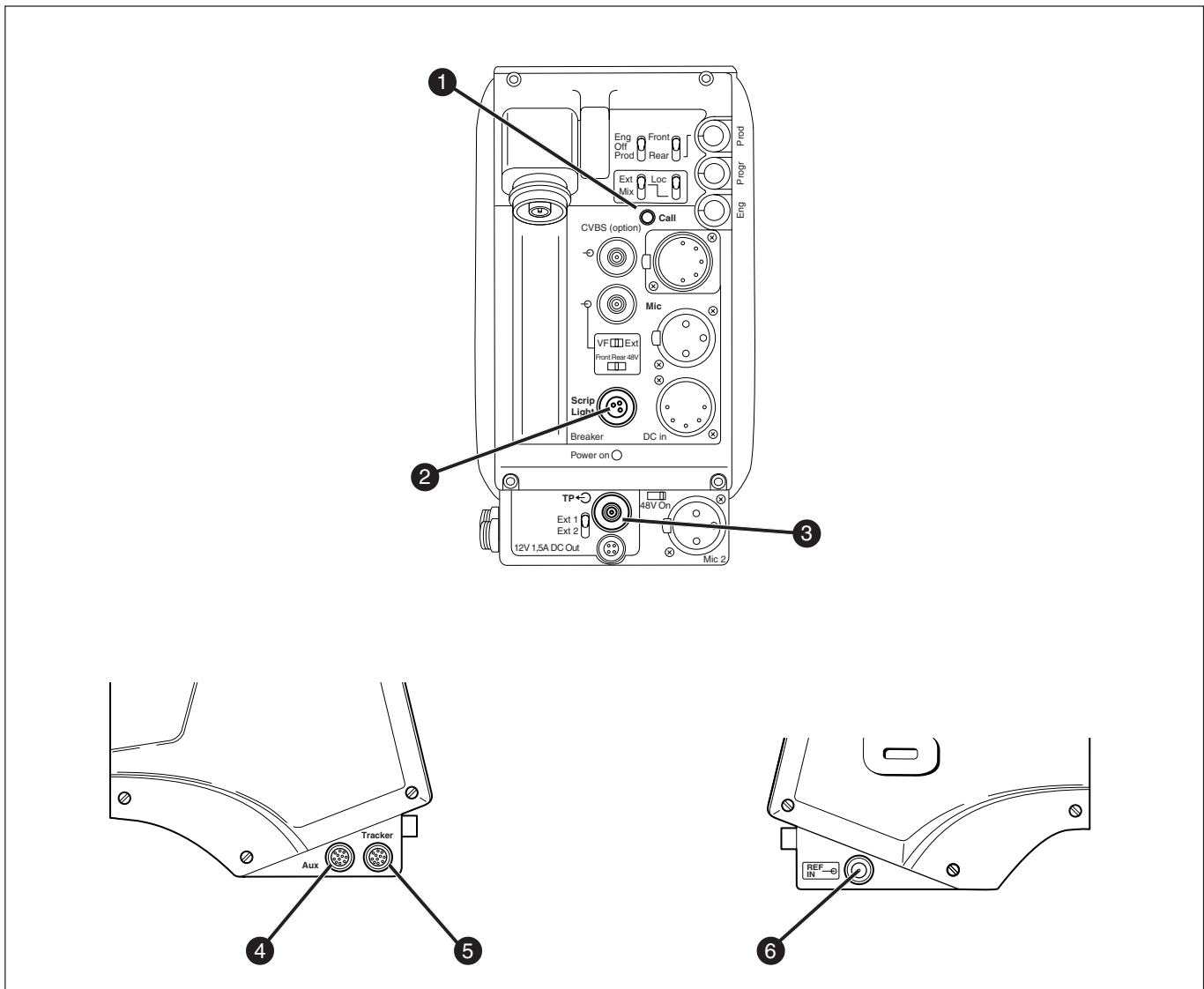

### 1 Call button

Pressing this momentary button sends a signal to the control panels calling for attention.

### 2 Script Light connector

A 3-pole socket which supplies +12 Vdc for a script light (maximum dissipation 0.25A). The optional script board (LDK 6985/15) is connected to this socket.

### 3 Teleprompter output socket

This BNC connector supplies the 1Vpp teleprompter signal applied to the base station.

### 4 Aux connector

This 11-pole female socket provides analogue control signals and facilities for the connection of a private data channel (see installation manual).

### 5 Tracker connector

This 11-pole female socket provides full intercom and signalling facilities for the dolly or crane driver (see installation manual).

### 6 Reference input socket

This BNC connector is used to supply a reference signal to the camera for genlocking.



---

# Section 5

## Shooting

*This section contains information on the practical use of the camera using the viewfinder display and the switches at the front to control the camera.*

### Contents

---

Using the Camera .....	5-2	Colour temperature selection .....	5-4
Colour Bar .....	5-3	Auto-White Balance .....	5-4
Gain selection .....	5-3	Shooting Screens .....	5-5
Optical filter selection .....	5-3	Exposure Time .....	5-6

# Using the Camera

---

The camera is operated via the viewfinder text display and the control system switches on the front panel. You have great detail and selection at your disposal when changing all the functions that are available in the camera. Refer to Section 6 - Operating the Menu System - for an explanation of the use of the menu selection structure and the viewfinder text display.

This section describes the operational functions that are available when using the camera via the viewfinder display and the switches at the front. These offer a convenient way of accessing the menu system which provides full control of the camera.

There are a number of steps that must be carried out before satisfactory shots can be obtained:

- a. The camera must be set up and powered.
- b. The standard settings must be recalled.
- c. Adjustments must be made for ambient lighting.

## Physical set-up and power supply

Attach lens, viewfinder, microphone and any other accessories to the camera as described in Section 2 - Assembling the Units.

Connect the triax cable to the triax connector and the camera operator's headset to the headset socket on the rear panel of the camera. Connect the audio microphone to either the audio socket on the right side of the camera or the socket on the rear. The camera is powered by the base station via the triax cable. Set the power switch on the left side of the camera to the on position.

## Operator preferences

With the owner card or the PIN code set the user level. The recommended minimum user level is 1. Setting the camcorder to level 0 is too restrictive for normal circumstances. For full control set the level to 3.

## Viewfinder preferences

Set up the viewfinder according to your own preferences; select markers, message boxes and on-screen display times.

## Lens preferences

Set up the lens according to the manufacturer's instructions. Select the lens type from two predefined settings; standard or wide angle. Choose and, if necessary, adjust the iris parameters to suit the lens and your personal preferences.

## Video preferences

The camera is now ready for use, however, the ambient conditions must now be taken into account and the appropriate adjustments made on the camera:

- a. Recall the standards settings.
- b. Switch off the colour bar (when on).
- c. Select the gain.
- d. Select a neutral density optical filter if required.
- e. Set a preset colour temperature or carry out the automatic white balance procedure.
- f. Select the correct exposure time.

**Note:** The number of functions available depends on the user level that has been set. Refer to Section 6 for more information on setting the user level.

## Colour Bar

---

The left side panel also contains a button for switching on the colour bar test signal. The colour bar is a standard test signal which is used to set up and check the camera before use.

When the colour bar is selected the following functions are temporarily set to the values listed below:

Black stretch	:	Off
White limiter	:	Off
Zebra	:	Off
Safe area (VF)	:	Off
Cadre (VF)	:	Off

## Optical filter selection

---

A neutral density filter and a special effect filter can be placed in the path of the optical signal to modify the incoming light. The filters are selected via the filter switches at the top-front of the camera. These filters can be used, for example, to control depth of field.

The camera does not need colour optical filters to be able to white balance correctly. The range of the auto-white balance is so wide (from 2.5K to 20K) that there is never any need to use colour filters to obtain the correct white.

## Gain selection

---

Depending on the available light levels it may be necessary to adjust the gain of the camera. The gain is selected via the Gain up/down switch on the left side panel. When this switch is pressed initially, the current value of the gain in dB is displayed in the viewfinder.

A new value is chosen by scrolling up or down through the five preset values (-, 0, +, ++ and +++). The actual dB value of these gain steps can be set in the install menu.

The -, + and ++ indicators at the top of the 2-inch viewfinder show which preset is selected.

For true colour reproduction the ambient lighting conditions must be compensated for by selecting a value for the colour temperature. The standard file setting is 3200K (normally used for tungsten light). Two other reference colour temperatures are available; 5600K (for outdoors, clouded conditions) and 7500K (for outdoors, clear blue skies).

Three similar memory positions (FL, AW1 and AW2) are available to store the results of the auto-white measurement process. The FL position is recommended for shooting with fluorescent light.

A continuous automatic white balance position (AWC) is also available. This function continuously measures the white balance and adjusts accordingly. It can be used when a constant colour balance is required under changing lighting temperatures (sunsets, indoors/outdoors use). When AWC is selected none of the colour temperature indicators in the 2-inch viewfinder light.

The colour temperature is selected via the up/down scroll switch (White Bal.) at the left-front side of the camera. The viewfinder displays the current value. A new value is chosen by scrolling up or down through the available values. The colour temperatures are shown in the following order:

White balance : 3200K  
 White balance : 5600K  
 White balance : 7500K  
 White balance : FL  
 White balance : AW1  
 White balance : AW2  
 White balance : AWC

The viewfinder displays the selected value and the actual measured colour temperature. The range of the auto-white balance is from 2.5K to 20K.

In the auto-white positions an electronic colour filter can be adjusted in the system Video menu. This varies the colour balance to obtain warmer or colder colour effects. When an automatic white balance process is performed, the electronic colour filter is reset to its default value.

If the reference colour temperatures do not match your lighting conditions carry out the auto-white procedure as follows:

- Use the colour temperature switch to select one of the memory positions FL, AW1 or AW2 in which to store the measured colour temperature value.
- Press once on the white balance switch at the front of the camera to start the automatic white balance procedure. The following appears in the viewfinder:

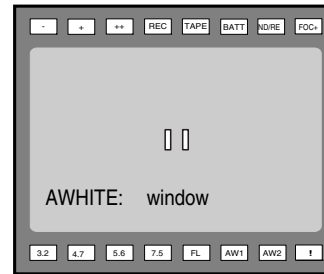

- Point the camera so that the reference white surface is between the two small white boxes.
- Press the white balance button again to start the measurement procedure. A message indicating that the process is running appears.



- When the process is completed (within a few seconds) the OK message and the measured temperature appear in the viewfinder.

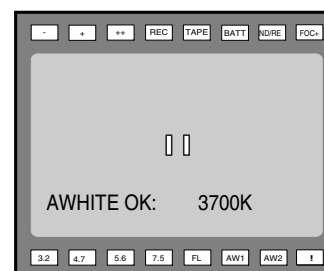

The measured colour temperature is now stored in the selected memory position and can be recalled as required. The camera is now ready for use.

**Note:** During the auto-white measurement process iris is set to Auto and 90% and the knee is turned off.

# Shooting Screens

---

Sometimes when shooting TVs or computer monitors a horizontal bar can be seen across those screens in the viewfinder. There are two ways of removing the noise bar from the picture depending on the frame frequency of the display. For displays with the same frame frequency as the camera, for example TV sets, use the V-shift facility. For displays with a higher frame frequency, for example computer monitors, use the Clean Scan facility.

## Clean Scan

Carry out the Clean Scan function as follows:

- a. press the Clean Scan button at the front of the camera for about two seconds to directly access the variable exposure (clean scan) function. The Clean Scan submenu appears in the viewfinder.
- b. Use the rotary control to change the value and so remove the horizontal black bar.
- c. If a more accurate adjustment is required set the Cl. Scan item to Extended.

**Note:** Set the Clean Scan mode to Normal if a smear effect occurs.

- d. Set the Unit item to the preferred read out - Hz or mSec.

When you are finished shooting the monitor press the Clean Scan button for two seconds to switch off the Clean Scan function. (Exposure Time returns to its previous non-variable setting).

The ranges are:

- from 50.6 to 125 for 50Hz video mode
- from 60.8 to 150 for 60Hz video mode
- from 24.4 to 96 for 25Hz or less video mode

## V-SHIFT

The vertical shift switch (V-SHIFT) at the front of the camera is used for displays with the same frame frequency as the camera, for example TV sets. It is an up/down type switch. Pressing the switch moves the black bar up or down so that it is no longer visible in the viewfinder. This function is only active when the camera is not genlocked and when it is not on-air.

If the frame frequencies of camera and monitor are different use the clean scan function.

## CRT Exposure

A third possibility can arise when shooting a monitor whose synchronization is locked to the camera's. Stripes might be visible in the picture of the monitor. (This is more usual with 16:9 cameras.) To remove these disturbing line pairing effects between monitor and camera lines, select the CRT option with the Exposure time switch.

## AFS

When shooting DLP type plasma screens colour shifts may occur due to the nature of the picture buildup. To avoid this switch on the AFS (Acquisition Frame Selection) that can be found in the install menu under 'Timing'. Adjust the AFS level until the colour shift disappears.

The exposure time values of 1/200, 1/500 and 1/1000 of a second are used to capture fast moving objects so that these can be played back sharply in slow motion. The value selected depends on the speed of the moving object.

**Note:** Increasing the exposure speed lowers the camera sensitivity proportionally.

The exposure selection also includes lighting control positions which can be used when shooting with lighting that is operating at a different frequency to the camera. There are two position 50 Hz and 60 Hz. Each of these positions can be varied further in a range from -10 to +10.

To reduce flicker select the frequency closest to the frequency of the lights and then vary the lighting control in the system Install menu to obtain the best result.

To assist with focussing through the viewfinder, a viewfinder zoom function is available which enlarges the centre of the viewfinder image. In the install menu you can choose a button to control this function:

- The VTR button on the camera,
- The VTR button on the lens,
- The RET switch on a zoom control when the camera is used with a large lens adapter.

The way these buttons operate when in the zoom mode can also be selected in the Install menu.

A crawler function (that can be switched on or off in the VF menu) adds motion in the viewfinder to objects in sharp focus.

---

# Section 6

## Using the Menu System

*Because the LDK 5000 offers such a wide range of functions, this section describes the structure of the control system. It contains procedures for controlling the menu system and explains how to program the menu system for your personal preferences. The menu structure and the methods of function selection are also explained.*

---

### Contents

Introduction .....	6-2
Systems Menu .....	6-3

## Introduction

---

Operationally, the camera is very easy to use. However, because of the large number of functions available and the large number of set-up options, it may require some time for you to become familiar with them all. We recommend that you spend time using the various controls and displays in order to discover the wide range of possibilities.

Read the instructions in this section carefully but also feel free to examine the various menus in detail. In this way you will learn quickly to intuitively operate the camera.

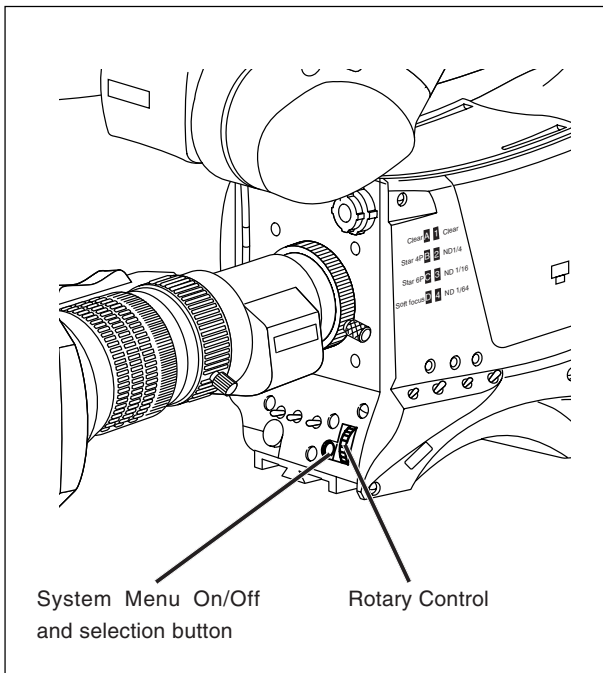



## Systems Menu

The system functions of the camera are grouped into menus and sub-menus. The systems menu is viewed in the viewfinder and navigated by means of the Rotary control and the Select button which are both located at the front of the camera.

### Entering the Systems menu

Press the Select button after the camera is switched on, the message **Menu off** appears in the viewfinder. Press the Select button again while this text is showing, the MAIN menu appears in the viewfinder.

The MAIN menu screen shows five items. The name of the menu is shown below these. Four more items are hidden but

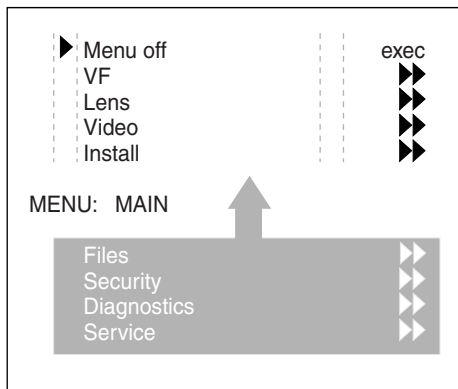

become visible when you scroll down using the rotary control. (Some of these items may not appear if the user level is not set to 3.)

A cursor shows your position in the menu. The Rotary control moves the cursor up and down.

### Finding your way

Use the Rotary control to move the cursor through the menu items. If a double arrow (>>) is visible, then pressing the Select button brings you one level lower in the menu system. Only five items are visible in each menu. Scroll up or down to see any additional items.

When you first enter a menu (other than the MAIN menu) the cursor is positioned next to the first item.

The TOP and PREVIOUS entries are not immediately visible but are located above the first item. Use the Rotary control to scroll up to them.

- Select TOP to bring you back to the MAIN menu.
- Select PREVIOUS to go back to the menu that you were in before the current one.

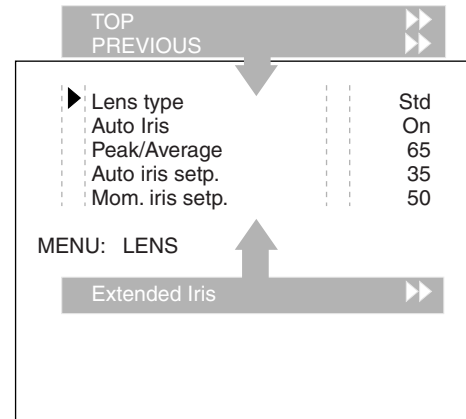

The LENS menu above shows the items displayed when you first enter the menu and the other items that are available by scrolling up or down with the Rotary control.

### Leaving the Systems Menu

If you are deep within the menu structure, follow these steps to leave:

- If necessary move the cursor to the leftmost column with the Select button.
- Scroll upwards with the Rotary control until the cursor points to TOP (this is the MAIN menu).
- Press the Select button. The cursor now points to the Menu off item of the MAIN menu.
- Press the Select button to leave the System menu.

This is the recommended way of leaving the System menu.

If you do not use the menu it disappears after a few seconds. (This delay can be programmed in the VF menu.) However, when you press the Select button again you enter the System menu at the last position of the cursor and not at the top of MAIN menu.

To prevent confusion the next time you enter the System menu, it is advisable to leave the System menu by returning to the MAIN menu (TOP) and selecting Menu off.

---

## Making changes

To find out where you have to go to change a function, consult the appendix to discover under which menu group or sub-group the function you want to change is located.

If the cursor points to an item (and there are no double arrows to indicate a sub-menu) then the item pointed to has a value.

The value can be:

- a toggle value (only two values)
- a list value (more than two values)
- an analogue value (variable from 00 to 99)
- or unavailable (---).

If the value is unavailable it cannot be changed. This is indicated by three dashes (---). This can occur, for example, when a function is switched off. The analogue values associated with that function are then unavailable.

If there are only two values associated with the function, then pressing the Select button toggles between these two values.

If a value is displayed next to a function that is one of several possible values, then pressing the Select button places the cursor in a list menu indicating the value currently selected. Use the Rotary control to point to a new value. Press the Select button to return the cursor to the function list.

If an analogue value is displayed next to a function name, then pressing the Select button places the cursor in front of the value and the Rotary control is used to change the analogue value. Press the Select button to return the cursor to the function list.

## Undoing changes

If you make changes to the video settings in the Systems menu and you decide not to keep them, use the Std. File button at the side of the camera to recall a standard set of values for the video parameters.

## Menu Structure

Access to the functions on these menus is determined by the user level that has been set. The menus are as follows:

### Main (top) menu

The top menu gives access to the other menus.

### VF menu

This menu contains the functions which determine how items in the viewfinder are displayed.

### Lens menu

The functions contained under this menu control various aspects of the lens.

### Video menu

The video menu contains those functions which affect the picture quality.

### Install menu

This menu contains the functions that are used to set up the general configuration of the camera. It also contains controls to customize those switches that are directly operated on the camera.

### Files menu

This menu allows values to be stored in scene and operator files, and allows these files to be recalled as required.

### Security menu

The security menu is used by the camera owner to set user levels and to control access to the camera, or to store the customer (scene and operator) default files.

### Diagnostic menu

The diagnostic menu is designed to provide information on the current status of the camera.

### Service menu

The advanced service menu is available to service engineers for carrying out adjustments and calibrations to the camera (see Technical Manual).

---

### **Security Menu for Owner's Access**

The Security menu provides restricted access to special set-up and security features of the camera.

Access to this menu requires the owner's unique smart card for the camera or the PIN code that has been set for the camera.

**Note:** An owner card is linked to the serial number of the camera and is unique to that camera. It cannot be used as an owner card for another camera.

Inserting the owner card into the camera gives direct access to the security menu. If you select the Security menu without this card inserted, you must enter the correct PIN code to gain access to the Security menu.

### **User Levels**

The installed user level function in the Security menu restricts access, in varying degrees, to the operational controls of the camera. There are four user levels: user0, user1, user2 and user3.

The purpose of the user levels is to restrict the set of functions which can be changed by whoever is using the camera. In this way a more centralized and uniform control can be achieved and the danger of the camera operator accidentally changing critical functions while shooting is reduced.

User level 0 is a special protection level which locks most of the operational controls of the camera. Use this level to ensure that a camera that has been set-up is not tampered with. User level 0 is not normally used for operational purposes.

The appendix indicates which functions are available at each user level.

### **Run Hours**

This sub-menu allows the date and time to be set and allows the running time of the camera to be viewed for the last 30 days.

### **PIN Code**

The PIN code of the camera can be viewed and changed in the Security menu.

The camera's PIN code when it leaves the factory is set to 0000. It is strongly advised that this code be changed by the owner on receipt of the camera. This ensures added protection against unauthorised access to the Security menu.

### **Standard customer file**

The green button on the side of the camera recalls the standard scene file. This file contains standard parameters for the picture performance.

A standard operator's file can be recalled via the Files menu. This file contains parameters for the set-up of the camera.

A customer standard file can be defined for the standard scene file and for the standard operator's file.

The contents of the customer files for both these standard files is stored via the security menu. The selection of a factory defined or a customer defined file for use as a standard file is also made in this menu.

---

## Files Menu Features

A user of the LDK 5000 camera can have access to 15 different files. This number can be extended by using additional scene file smart cards. The Files menu is used to recall and store these files. There are two types of file:

- \* scene files
- \* operator files.

A scene file contains values related to the picture performance. The operator file contains values related to the set-up of the camera (viewfinder, lens and installation parameters). The appendix indicates the functions that are stored in the scene file and those functions that are stored in an operator file.

### Scene files

Four scene files are stored in the camera itself (SCAM1, SCAM2, SCAM3 and SCAM4). Another four scene files can be stored on the smart card (SCARD1, SCARD2, SCARD3 and SCARD4).

A STANDARD scene file (preselected as either factory or customer defined) is stored in the camera.

**Note:** The standard customer scene file is stored via the Security menu, not the Files menu. The decision to use the factory defined file or the customer defined file as the standard file is also made in this menu.

The Files menu enables the scene files to be stored and recalled using the store and recall entries of the menu system. If the message NOK is displayed then the old values are restored. If the camera is on-air when a scene file is recalled then the recalled values do not become active until the camera goes off air.

### Operator files

The Files menu also allows the recall of the operator file stored in the camera (OCAM1) or one of the two operator files (OCARD1 and OCARD2) stored on the smart card. These files contain information for setting up the non-video configuration of the camera.

A STANDARD operator files (factory or customer defined) is stored in the camera.

**Note:** The standard customer operator file is stored via the Security menu, not the Files menu. The decision to use the factory defined file or the customer defined file as the standard file is also made in this menu.

## Install Menu Features

### Gain

The gain can be selected in five steps: -, 0, +, ++ and +++. The actual value of the gain in dB can be assigned to these symbols. This is done in the Install menu.

### Disable camera

The disable camera function is a protection function which prevents unauthorised interference with the camera and provides an additional level of security. Setting disable camera to ON is similar to using User level 0 to protect the settings of the camera.

---

# Appendix

---

## Contents

System Menu Structure .....	A-3	List of Abbreviations .....	A-17
List of System Menu Functions .....	A-15		

---

The appendix contains two types of table listing the contents of the menu system. A list of abbreviations is also included.

The System Menu tables present the functions ordered in the logical divisions of the menu system itself with additional information in the columns:

- **User level column**  
The User level column indicates the functions that are available with different user levels.
- **Values column**  
All available choices are listed for a function.
- **Blocked if column**  
Lists the conditions that block the function.
- **Default column**  
The default column lists the values of the functions when a camera is delivered.
- **Files column**  
The File column indicates where the value of the function is stored; in the operator file or in the scene file or not at all.

The second table "List of Systems Menu Functions" contains an alphabetical list of the System menu functions. This table is used to find the menu path to a function and assists in navigating to that function.

---

Main Menu						
Menu text		User	Values	Default	Blocked if	File
<b>VF</b>	>>	0				
<b>Lens</b>	>>	0				
<b>Video</b>	>>	2				
<b>Install</b>	>>	0				
<b>Files</b>	>>	1				
<b>Security</b>	>>	0				
<b>Diagnostics</b>	>>	2				
<b>Service</b>	>>	3				

VF Menu					
Menu text	User	Values	Default	Blocked if	File
<b>VF mon</b>	2	Y,R,G,B,-G	Y	-	oper
<b>VF Contour</b> >>					
VF Contour	2	On, Off	On	-	oper
Level	2	0..99	50	VF cont. Off	oper
<b>Focus Assist</b>	0	On,Off	Off	-	oper
<b>Zebra</b> >>					
Zebra	3	On,Off	Off	2" VF used	oper
zebra mode	3	Level, band (-5..5)	Level	Zebra Off	oper
zebra level (%)	3	0..99	90	Zebra Off	oper
zebra contrast	3	0..99	15	Zebra Off	oper
<b>Centre Cross</b>	0	On,Off	Off	-	oper
<b>Safe Area</b>	0	On,Off	Off	-	oper
<b>Audio Bar</b>	0	On,Off	Off	Triax	oper
<b>Iris Ind.</b>	0	On,Off	Off	SuperXPander	oper
<b>Focus Ind.</b>	0	On,Off	Off	No SuperXPander	oper
<b>Zoom Ind.</b>	0	On,Off	Off	-	oper
<b>Box downright</b>	0	Filtr,Off	Off	-	oper
<b>Marker</b>	0	Off,16:9,15:9,14:9	Off	-	oper
<b>Marker 4:3</b>	0	On,Off	Off	-	oper
<b>Marker Type</b>	0	Dot,Shad, Both	Dot	-	oper
<b>Ind. White</b>	2	0..99	70	-	oper
<b>Ind. Black</b>	2	0..99	30	-	oper
<b>Display</b>	2	On,Time	Time	-	oper
<b>Menu Time</b>	3	0..10 sec.	10	Display On	oper
<b>Info Time</b>	3	0..20 sec.	5	-	oper
<b>Rotary Speed</b>	3	0..10	5	-	oper
<b>VF Notch</b>	2	On,Off	Off	-	oper
<b>EXT AspectRatio</b>	0	4:3,16:9	4:3	-	oper
<b>INT AspectRatio</b>	0	4:3,16:9	16:9	-	oper
<b>VF Zoom Switch</b>	0	Mom., Alt.	Mom.	-	oper



Lens Menu					
Menu text	User	Values	Default	Blocked if	File
<b>Lens Type</b>	0	Std,WA	STD	-	oper
<b>Auto Iris</b>	0	On, Off	Off	SuperXPander	
<b>Peak/Average</b>	3	0..99	65	Auto Iris off	scene
<b>Autolris Setpoint</b>	3	0..99	35	-	scene
<b>Mom. Iris Setpoint</b>	3	0..99	50	-	scene
<b>Manufacturer</b>	0	Fuj1,Fuj2,Can,Other	Fuj1	-	-
<b>Extended iris</b>	>> 3				
GainSpeed	S	0..99	5	-	oper
ExpTimeSpeed	S	0..99	4	-	oper
Min iris	3	F5.6, 8, 11, 16	F16.0	-	oper
Max iris	3	F1.4, 2, 2.8, 4, 5.6	F2.0	-	oper
Min exp time	3	1/100, 1/200, 1/500	1/500	-	oper
Max Gain (dB)	3	0..15 (steps of 3)	15dB	-	oper
<b>Autoiris const</b>	>> 3				
Iris gain		5..10	5	-	-

Video Menu					
Menu text	User	Values	Default	Blocked if	File
<b>Colour filter</b>	2	00 .. 99	50	3k2,4K7,5K6,7K5 or AWC	scene
<b>Contour</b> >>					
Contour	S	Off, On	On	-	scene
Level	3	00..99	50	Contour = Off	scene
Source Select	>>	3	Y,R,G,RG	R+G	-
<more>	>>				
vert cont	3	0..99	25	Contour = Off	scene
coarse/fine	3	0..99	50	Contour = Off	scene
Level	S	0..99	50	Contour = Off	scene
Level dep.	S	0..99	40	Contour = Off	scene
noise slicer	S	0..99	5	Contour = Off	scene
<b>Soft Contour</b> >>					
Soft Contour	2	Off, On	Off	-	scene
Level	2	0..99	70	Soft Cont = Off	scene
<b>Knee Contour</b>	3	Off, 1,2,3,4	Off		scene
<b>Skin</b> >>					
Skin	2	Off, 1, 2, 1+2	Off	-	scene
Auto	2	Off, On	Off	Skin = Off or 1+2	-
View	2	Off, On	Off	Skin = Off	
Skin Level	2	0..99	50	Skin = Off	scene
<more>	>>				
width1 Red	3	0..99	50	Skin <> 1	scene
width1 Blue	3	0..99	50	Skin <> 1	scene
color1 Red	3	0..99	50	Skin <> 1	scene
color1 Blue	3	0..99	50	Skin <> 1	scene
width2 Red	3	0..99	50	Skin <> 2	scene
width2 Blue	3	0..99	50	Skin <> 2	scene
color2 Red	3	0..99	50	Skin <> 2	scene
color2 Blue	3	0..99	50	Skin <> 2	scene
<b>Flare</b> >>					
Flare	S	Off, On	On	-	scene
Red	S	0..99	10	Flare = Off	scene
Green	S	0..99	15	Flare = Off	scene
Blue	S	0..99	25	Flare = Off	scene
<b>Black</b> >>					
Dyn. Black	2	Off, On	-	Triax	-
Black stretch	3	0...99	99	Blk str = Off	scene
Master	2	0..99	50	-	scene
<more>	>>				
Red	3	0..99	50	-	scene
Green	3	0..99	50	-	scene
Blue	3	0..99	50	-	scene
Master	3	0..99	50	-	scene

Video Menu (continued)					
Menu text	User	Values	Default	Blocked if	File
<b>Gain</b> >>					
Red	2	0..99	50	-	scene
Green	2	0..99	50	-	scene
Blue	2	0..99	50	-	scene
<b>Knee</b> >>					
Knee	2	Off, Var	Off	-	scene
Knee Type	3	Y, NAM	Y	-	scene
Slope M	3	0..99	60	knee <> var	scene
Point M	3	0..99	50	knee <> var	scene
<more> >>					
Knee Limit	S	0..99	99	knee <> var	scene
Desaturation	S	Off, On	On	knee=off	scene
Desat Level	S	0..99	50	desat = off	scene
Auto Point	S	0..99	30	knee <> auto	scene
Auto Ref	S	0..99	30	knee <> auto	scene
<b>Gamma</b> >>					
Gamma	2	Nom,Low,Pre	Nom	-	scene
Master	3	0..99	76	gamma <> Pre	scene
Red	3	0..99	76	gamma <> Pre	scene
Green	3	0..99	76	gamma <> Pre	scene
Blue	3	0..99	76	gamma <> Pre	scene
<more> >>					
Curve	S	BBC04, BBC05, BBC06, ARD, 6xARD, CCIR, RAI	ARD	-	scene
Gamma	S	Gamma, Lin	gamma	-	scene
<b>Matrix</b> >>					
Matrix	3	EBU, RAI, BBC ,B/W, SKIN, 1:1,CFL,VAR1, VAR2	Skin	-	scene
R..G	S	0..99	--	Matrix <> Var	scene
G..R	S	0..99	--	Matrix <> Var	scene
R..B	S	0..99	--	Matrix <> Var	scene
B..R	S	0..99	--	Matrix <> Var	scene
G..B	S	0..99	--	Matrix <> Var	scene
B..G	S	0..99	--	Matrix <> Var	scene
Matrix / Gamma	S	G/M, M/G	G/M	-	scene
<b>White Limit</b> >>	S				
White Limit	S	Off, On	On	-	scene
Master	S	0..99	80	Wh.Limit = Off	scene

Video Menu (continued)					
Menu text	User	Values	Default	Blocked if	File
<b>Shading</b>					
Shading	S	Off, On	On	-	scene
H saw red	S	0..99	50	Shading = Off	-
H saw green	S	0..99	50	Shading = Off	-
H saw blue	S	0..99	50	Shading = Off	-
H par red	S	0..99	0	Shading = Off	-
H par green	S	0..99	0	Shading = Off	-
H par blue	S	0..99	0	Shading = Off	-
V saw red	S	0..99	50	Shading = Off	-
V saw green	S	0..99	50	Shading = Off	-
V saw blue	S	0..99	50	Shading = Off	-
V par red	S	0..99	0	Shading = Off	-
V par green	S	0..99	0	Shading = Off	-
V par blue	S	0..99	0	Shading = Off	-
<b>Saturation</b>	2	0..99	50	-	-

Install Menu (LDK 5440 Triax Adapter)					
Menu text	User	Values	Default	Blocked if	File
<b>Disable Camera</b>	0	Off, On	Off	-	-
<b>IR receiver</b>	0	Off, On	Off	-	oper
<b>OnAir Lamp</b>	0	Off, On	On	VF<> 7"	oper
<b>Intercom</b> >>					
Side tone	1	0...99	50	-	oper
Cam. Mic	1	On,Off,Switch	Off	Cam. Mic=On	oper
Cam. Mic Gain	1	0dB,40dB	40dB	-	oper
Cam. Mic Power	1	On,Off	Off	-	oper
Cam. Production	1	Off,Left,Right,Both	Off	-	oper
Cam. Engineering	1	Off,Left,Right,Both	Off	-	oper
Cam. Program	1	Off,Left,Right,Both	Off	-	oper
Cam. Track	1	Off,Left,Right,Both	Off	-	oper
Cam. Track level	1	0...99	50	-	oper
Track Mic To	1	Off, Cam, Eng, Prod, All	Off	-	oper
Track Mic Gain	1	0dB,40dB	40dB	-	oper
Track Mic Power	1	On,Off	Off	-	oper
Track Source	1	Side, Eng	Side	-	oper
Cam. Mic To	1	CH1, CH2	CH1	-	oper
<b>Audio</b> >>					
Audio 1 Gain	1	-22,-28,-34,-40,-46,-52, -58, 64	-64	-	oper
Audio 1 HPF	1	On,Off	Off	-	oper
Audio 2 Gain	1	-22,-28,-34,-40,-46,-52, -58, 64	-64	-	oper
Audio 2 HPF	1	On,Off	Off	-	oper
<b>Notch</b>	3	Off, On	Off	-	oper
<b>Exposure</b> >>					
Lighting	1	-10..+10	0	Exp.<> 50,60Hz	scene
Clean Scan >>	1				
Cl.Scan Mode	1	Normal,Extended	Normal	-	scene
Value	1	See section 5 'Shooting Screens'	-	-	scene
Units	1	Hz, mSec	mSec	-	scene
<b>Gain preset</b> >>					
Gain - (dB)	2	-3,-6	-3dB	-	oper
Gain + (dB)	2	3,6,9	3dB	-	oper
Gain ++ (dB)	2	6,9,12	6dB	-	oper
<b>Autowhite</b> >>				Coltemp<>AW	
Awb speed	S	0..99	4	-	oper
Awb gain	S	0..99	10	-	oper
<b>Timing</b>				Coltemp<>AW	
H.Phase	0	0..99	50	-	oper
AFS	0	Off, On	Off	-	oper
AFS Level	0	0..99	-	AFS = Off	oper
<b>Private Data</b>	0	C->B,B->C,B<->C	Inter	-	oper

Security Menu					
Menu text	User	Values	Default	Blocked if	File
<b>Installed Level</b>	2	user0..user3	u3	no owner card, no PIN	-
<b>Run Hours</b> >>				no owner card, no PIN	
Days ago	2	0 ... 30	0		-
<b>Set Time</b> >>					
Hour	2	0 ... 23	-		-
Minute	2	0 ... 59	-		-
<b>Set Date</b> >>					
Year	2	0 ... 99	-		-
Month	2	1 ... 12	-		-
Day	2	1 ... 31	0		-
<b>PIN code</b> >>				no owner card, no PIN	
Four digits	0	0000 ... 9999	0000	-	-
<b>Customer files</b> >>				no owner card, no PIN	
Store cust. Scene	0	Exec		-	
Store cust. Oper	0	Exec		-	
<b>Green Button</b> >>				no owner card, no PIN	
Standard	0	Factory/Customer	Factory	-	
Scene file	0	On,Off	On	-	
Operator file	0	On,Off	On	-	

Files Menu					
Menu text	User	Values	Default	Blocked if	File
<b>Store scenefile</b> >>					
File select	2	SCAM1..4, SCARD 1..4	-	-	-
Store	2	Exec	-	-	-
<b>Recall scenefile</b> >>					
File select	2	STANDARD, SCAM1..4, SCARD 1..4	-	-	-
Recall	2	Exec	-	-	-
<b>Store oper. file</b> >>					
File select	1	OCAM 1, OCARD 1..2	-	-	-
Store	1	Exec	-	-	-
<b>Recall oper. file</b> >>					
File select	1	STANDARD, OCAM 1, OCARD 1..2	-	-	-
Recall	1	Exec	-	-	-
<b>Attributes</b> >>					
File select	2	available files	-	-	-
File name	2		-	-	-
Attribute	2	R/W, R	R/W	no card	-
<b>Standard files</b> >>				not installed	
Standard settings	2	Exec	-	-	-
Lighting			-	-	-
Night	2	Exec	-	-	-
Fluorescent	2	Exec	-	-	-
Extreme contrast	2	Exec	-	-	-
Creative			-	-	-
Sport warm colour	2	Exec	-	-	-
Sport interview	2	Exec	-	-	-
HI film	2	Exec	-	-	-
HI film + skin	2	Exec	-	-	-
LO Film	2	Exec	-	-	-
LO film + skin	2	Exec	-	-	-
Sepia film	2	Exec	-	-	-
Matching			-	-	-
LDK9x + LDK10	2	Exec	-	-	-
DVW-xxx	2	Exec	-	-	-
HL-xxx	2	Exec	-	-	-
Standard settings	2	Exec	-	-	-

Diagnostic Menu					
Menu text	User	Values	Default	Blocked if	File
<b>Communication</b> >>				LDK 5600	
Base Station	2	Ok, NotOk	-	-	-
OCP	2	Ok, NotOk	-	-	-
MCP	2	Ok, NotOk	-	-	-
<b>Adaptor Type</b>	2	Triax, DVCPRO, .....	-	-	-
<b>Sensor Type</b>	2	IT,ITW,FT,DPM	-	-	-
<b>Sensor Voltage</b>	2	Ok, NotOk	-	-	-
<b>Shutter Run</b>	2	Run, Stop	-	-	-
<b>Front Power</b>	2	Ok, NotOk	-	-	-
<b>Y carrier</b>	S	Ok, NotOk	-	-	-
<b>Cam. 12nc</b>	2	...	-	-	-
<b>Cam. Version</b>	S	...	-	-	-
<b>Cam. Status</b>	2	...	-	-	-
<b>Cam. Boot ver.</b>	2	...	-	-	-
<b>Cam. FPGA ver.</b>	2	...	-	-	-
<b>Adapter 12nc</b>	2	...	-	-	-
<b>Adapter Status</b>	S	...	-	-	-
<b>PPG Status</b>	S	...	-	-	-
<b>DVP Status</b>	S	...	-	-	-



Service Menu					
Menu text	User	Values	Default	Blocked if	File
<b>Sawtooth</b>	3	Off, On	Off	-	-
<b>Sawt Select</b>	3	PrPr, Asic	PrPr	-	-
<b>ViPr Test</b>	S	Int/Ext	Int	-	-
<b>LPC</b>	S	Off, On	On	-	-
<b>BPC</b>	S	Off, On	On	-	-
<b>Chroma</b>	0	Off, On	On	-	-
<b>Calibrations</b>	>>				
Video ADC	2	Off, Run	Off	-	-
3200K	S	Off, Run	Off	-	-
3200K reset	S	Cust,Fact	Fact	-	-
Pulse comp	S	Off, Run	Run	-	-
<b>Calib. Params</b>	>>				
Tolerance (0.1%)	S	1..25	3	-	-
<b>Scaler</b>	>>				
Encoder		Off,On	Off	-	
SDI	3	Off,On	Off	-	
Encoder Colourbar	3	Off,On	Off	-	
EPLD Test	3	Off,Sawt,Bars	Off	-	
Chroma	0	Off, On	On	-	-

Function	Path in Menu
Marker	VF
Marker Type	VF
Matrix select	Video \ Matrix
Matrix parameters	Video \ Matrix
Master black	Video \ Black
MCP	Diagnostics \ Communication
OCP	Diagnostics \ Communication
On Air lamp switch	Install \ On Air Lamp
Operator file recall	Files \ Recall oper. file
Operator file store	Files \ Oper. file
PIN code	Security
Quick Smart Touch	Install \ Quick Smart Touch
Recall Scene file	Files
Recall Oper. file	Files
Run Hours settings	Security
Rotary speed	VF
Sawtooth switch	Service
Scene file recall switch	Files \ Recall Scenefile
Scene file store switch	Files \ Store Scenefile
Sensor Type	Diagnostics
Sensor Voltage	Diagnostics
Shading parameters	Video \ Shading
Shading switch	Video \ Shading
Shutter Run	Diagnostics
Shutter phase	Service
Standard files	Files
Standard Settings	Files \ Standard Files
Store Scene file	Files
Store oper. file	Files
Software status	Diagnostics
Tally Light switch	Install
Tolerance	Service \ Calib. Params
User level select	Security \ Installed level
VF	
4:3 Area type	VF
Audio Bar switch	VF
Contour level	VF \ VF Contour
Contour switch	VF \ VF Contour

Function	Path in Menu
Centre Cross switch	VF
Focus ind. switch	VF
Iris Indicator switch	VF
Info time	VF
Menu time	VF
Rotary speed	VF
Safe Area switch	VF
Text Display time	VF
Zebra switch	VF
Zebra parameters	VF
Zoom ind. switch	VF
ViPr Test select	Service
White Limit switch	Video \ White Limit
White Limit Master	Video \ White Limit
Zebra	
Contrast	VF \ Zebra
level	VF \ Zebra
mode	VF \ Zebra
switch	VF \ Zebra

## List of Abbreviations

Abbreviation	Meaning
adap	adapter
agc	automatic gain control
awb	automatic white balance
bal	balance
cam	camera
ch	channel
cont	contour
ctemp	colour temperature
ctl	control track longitudinal
cus	customer
df	drop frame
dyn	dynamic
exec	execute
exp	exposure
ext	external
ext	extended
flt	filter
fr	front
frm	frame
f-run	free run
hd	head
hr	hour
ind	indicator
info	information
interv	interview
intv	interview
ir	infra-red
lvl	level
man	manual
max	maximum
mic	microphone
min	minute
min	minimum
mom	momentary
mon	monitor
nam	non-additive mix
nd	neutral density
ndf	no drop frame

Abbreviation	Meaning
ocam	camera operator file
ocard	smart card operator file
op	operation
oper	operator
outp	output
ovl	overload
pin	personal identification number
r/w	read/write
re	rear
repl	replay
r-run	record run
rst	reset
sawt	sawtooth
scam	camera scene file
scard	smart card scene file
sec	second
sel	select
srch	search
st	stereo
std	standard
str	stretch
tc	time code
tm	timer
ub	user bits
unbal	unbalanced
und	underload
var	variable
ver	version
vert	vertical
vf	viewfinder
wa	wide angle
wh	white
wrn	warning
wrx	wireless receiver

