

Telecast Fiber Solutions

Rattler 4 User Guide

M4027-9900-103

24 February 2015



Copyright & Trademark Notice

Copyright © 2013–2014, Grass Valley. All rights reserved.

Belden, Belden Sending All The Right Signals, and the Belden logo are trademarks or registered trademarks of Belden Inc. or its affiliated companies in the United States and other jurisdictions. Grass Valley, Rattler 4 are trademarks or registered trademarks of Grass Valley. Belden Inc., Grass Valley, and other parties may also have trademark rights in other terms used herein.

Terms and Conditions

Please read the following terms and conditions carefully. By using Rattler 4 documentation, you agree to the following terms and conditions.

Grass Valley, a Belden Brand (“Grass Valley”) hereby grants permission and license to owners of Rattler 4 to use their product manuals for their own internal business use. Manuals for Grass Valley products may not be reproduced or transmitted in any form or by any means, electronic or mechanical, including photocopying and recording, for any purpose unless specifically authorized in writing by Grass Valley.

A Grass Valley manual may have been revised to reflect changes made to the product during its manufacturing life. Thus, different versions of a manual may exist for any given product. Care should be taken to ensure that one obtains the proper manual version for a specific product serial number.

Information in this document is subject to change without notice and does not represent a commitment on the part of Grass Valley.

Warranty information is available in the Support section of the Grass Valley Web site (www.miranda.com).

Title	Rattler 4 User Guide
Part Number	M4027-9900-103
Revision	24 February 2015

toc

Table of Contents

1 Introduction	1
About Rattler 4	2
About This User Guide	3
Available Rattler 4 Models	4
Rattler Kits	6
Unpacking the Rattler 4	7
Product Returns	7
Optical Fiber Safety	7
Electromagnetic Compatibility	8
2 Rattler 4 Operation	9
Rattler 4 Single Unit Components	10
LED Display Operation	11
Rattler Tx Unit	11
Rattler Rx Unit	11
Rattler 4 Dual Unit Operation	12
Using the PicoLink pL-Tray to Rack Mount the Rattler 4	13
Fiber Optical Channel Monitoring using the LED Display	14
3 Best Practices	15
Best Practices	16
Troubleshooting	16
Block Diagram	17
4 Specifications	19

1 Introduction

This chapter describes the Rattler 4 system, including safety, warranty, and specification information.

<i>About Rattler 4</i>	2
<i>Available Rattler 4 Models</i>	4
<i>Unpacking the Rattler 4</i>	7

About Rattler 4

The Rattler 4 is a miniature HD/SDI to fiber optical signal converter. The Rattler 4 TX Transmitter unit accepts a 75 ohm coaxial input and converts it into an optical signal via a standard ST connector. The Rattler 4 RX Receiver unit reconverts the signal back to a BNC output.



Fig. 1-1: Rattler 4 TX and TR Units

The Rattler 4 can transmit any of the following signal types:

- 3 Gbps SMPTE 424M HD-SDI
- 1.5 Gbps SMPTE 292M HD-SDI
- 19.4 Mbps SMPTE310M
- 143 to 540 Mbps SMPTE2 59M/344M
- DVB/ASI 270 Mbps
- AES and MADI audio
- plus non-standard digital signals to 3 Gbps

The Rattler 4 is available in single and dual receiver and transmitter units as well as a dual Transceiver unit.

Transmitters are available in standard 1310 wavelength, 1550 WDM wavelength, and CWDM wavelengths. All 18 standard CWDM wavelengths are available. For CWDM transmitters, an appropriate CWDM multiplexer (such as Grass Valley's passive CWDM units) should be used to combine multiple CWDM signals from CWDM Rattler 4s and other devices. An appropriate demultiplexer should be used (such as Grass Valley's passive CWDM units) when using Rattler 4 receivers or the Grass Valley Python or Telethon active demultiplexers and media converters.

Physically compact at 3.2 inches in length, the units are color-coded with Blue for Receivers and Red for Transmitters.

All Rattler 4 units come with a permanently attached mini-XLR power connector . Power comes from the supplied power supply or any mini-XLR jack equipped power supply providing 5-16 volts VDC.

All units come with a set of power and signal LED indicators .

- The Receiver units have a four LED array to indicate signal strength.
- The Transmitter unit has a single LED to indicate signal presence.

The Rattler 4 is fully interoperable with a wide range of Grass Valley series fiber optic equipment as well as other manufacturers. Certain Grass Valley PicoLink accessories may be used with the Rattler 4 units. Please see your authorized Grass Valley series dealer for more information (see [Contact Us](#) on page 21).

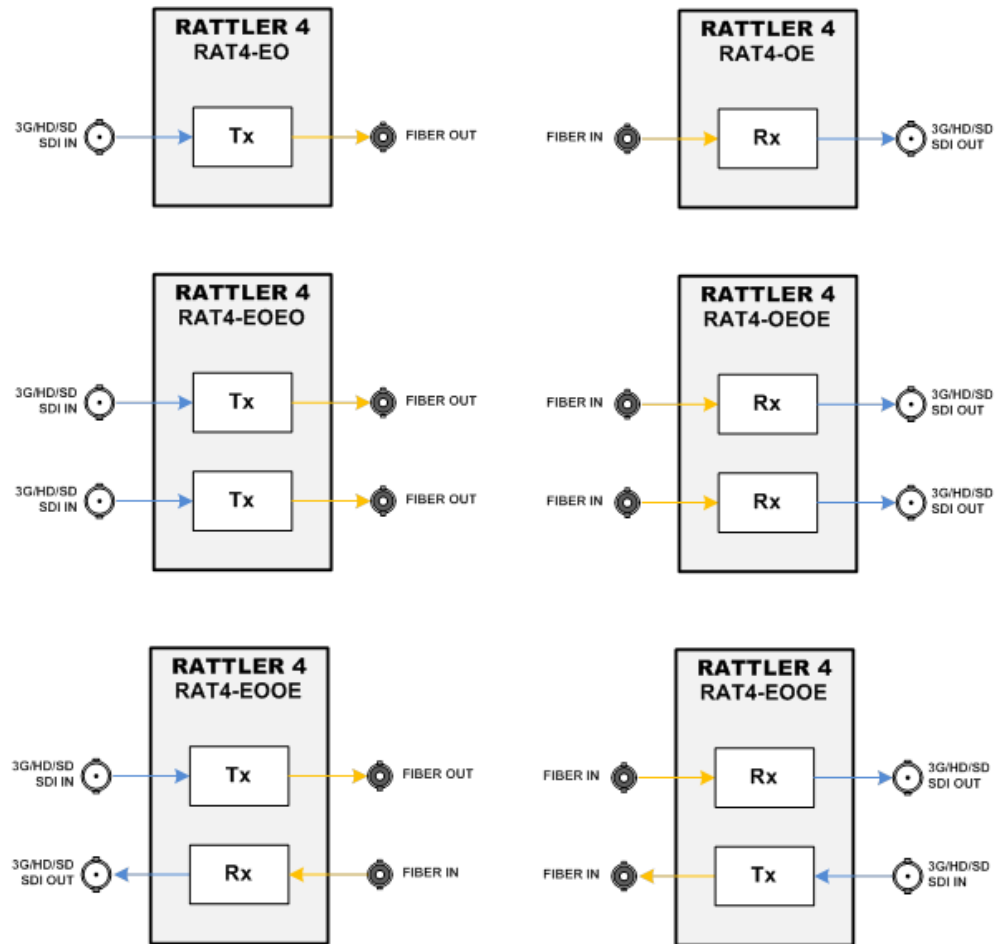

Fig. 1-2: Rattler 4 Block Diagrams

About This User Guide

The Rattler 4 is available in five standard models:

- Single Tx
- Single Rx
- Dual Tx
- Dual Rx
- Bi-Directional Transceiver

Each of these models is described in this User Guide. Kits of matched pairs and various accessories are also available.

Available Rattler 4 Models

All Rattler 4 Units come with a Mini-XLR locking power cord.

Model	Type	BNC Connector	ST Connector	Fiber Optic Wavelength	CWDM
-------	------	---------------	--------------	------------------------	------



Single Transmitter Unit

RAT4-EO-MXLR	Transmitter	Input	Output		No
--------------	-------------	-------	--------	--	----





Single Receiver Unit

RAT4-OE-MXLR	Receiver	Output	Input		No
--------------	----------	--------	-------	--	----



Single Transmitter Units with CWDM

RAT4-EO-1271-MXLR	Transmitter	Input	Output		Yes
RAT4-EO-1291-MXLR	Transmitter	Input	Output		Yes
RAT4-EO-1311-MXLR	Transmitter	Input	Output		Yes
RAT4-EO-1331-MXLR	Transmitter	Input	Output		Yes
RAT4-EO-1351-MXLR	Transmitter	Input	Output		Yes
RAT4-EO-1371-MXLR	Transmitter	Input	Output		Yes
RAT4-EO-1391-MXLR	Transmitter	Input	Output		Yes
RAT4-EO-1411-MXLR	Transmitter	Input	Output		Yes
RAT4-EO-1431-MXLR	Transmitter	Input	Output		Yes
RAT4-EO-1451-MXLR	Transmitter	Input	Output		Yes
RAT4-EO-1471-MXLR	Transmitter	Input	Output		Yes
RAT4-EO-1491-MXLR	Transmitter	Input	Output		Yes
RAT4-EO-1511-MXLR	Transmitter	Input	Output		Yes
RAT4-EO-1531-MXLR	Transmitter	Input	Output		Yes
RAT4-EO-1551-MXLR	Transmitter	Input	Output		Yes
RAT4-EO-1571-MXLR	Transmitter	Input	Output		Yes

Model	Type	BNC Connector	ST Connector	Fiber Optic Wavelength	CWDM
RAT4-EO-1591-MXLR	Transmitter	Input	Output		Yes
RAT4-EO-1611-MXLR	Transmitter	Input	Output		Yes
 <p>Dual Transmitter Unit</p>					
RAT4-EOEO-A-MXLR	Dual Transmitter	2 Inputs	2 Outputs	1310 nm	No
 <p>Dual Receiver Unit</p>					
RAT4-OEOE-MXLR	Dual Receiver	2 Outputs	2 Inputs	Not Applicable	No
 <p>Transceiver Unit</p>					
RAT4-EOOE-A-MXLR	Transmitter Receiver	Input Output	Output Input	1310 nm Not Applicable	No No

Rattler Kits

All kits come in a Injection Molded Road Case (RAT4-KIT-CASE can be ordered separately) with two LKS-WSU power supplies.

- **RAT4-KIT1-T-MXLR:** consists of one RAT4-EO-A-MXLR Transmitter and one RAT4-OE-MXLR Receiver
- **RAT4-KIT2-TT-MXLR:** consists of one dual RAT4-EOEO-A-MXLR Transmitter and one dual RAT4-OEOE-MXLR Receiver
- **RAT4-KIT3-TR-MXLR:** consists of two RAT4-EOOE-A-MXLR Transceivers

Unpacking the Rattler 4

Please consult your packing slip and purchase order to ensure that you have received all of the expected components.

Inspect all components for scratches and other mechanical damage, and inspect the electrical connectors for bent or damaged pins and latches. Report any missing or damaged components to Grass Valley, a Belden Brand (see [Product Returns](#) on page 7).

Product Returns

In the unlikely event of damage to your Rattler 4 during shipping or delivery, take note or any damage with the delivery or shipping service. If any component does not work correctly out of the box, contact Grass Valley, a Belden Brand (see [Contact Us](#) on page 21).

If the problem cannot be remedied through a service telephone call, you will receive an RMA number (Return of Merchandise Authorization). Please note this RMA number inside and outside of all shipping boxes and on all documentation provided with the items to be returned.

Optical Fiber Safety

- Never look directly into the end of the optic fiber while either end of the system is operating.
- This Rattler 4 contains CDRH Class 1 laser devices. To prevent damaging your eyes, always avoid looking directly at, or staring into, the laser light located on an optical connector or on the end of a fiber.
- Infrared radiation (invisible to the human eye) is produced at the ST fiber connection and at the end of any un-terminated optical fibers that are attached to this connection. Avoid any direct exposure to the light that comes from these sources.
- Do not power up the unit if there are no fiber connectors attached to the fiber port.
- There are no manual adjustments to be made inside the Rattler 4. Do not attempt any type of service to this instrument, other than any as instructed this User Guide. Refer all servicing to Grass Valley, a Belden Brand.
- Always keep the Fiber Optical connectors protected when not connected. Use protective caps if available. This protects the connector from damage and the unlikely event of exposure to an operating optical link. Keeping the connectors protected when the connectors are not in use will prevent dirt and dust from entering the connector and degrading the performance of the optical link.
- You should read the **Using Fiber Optics Guide** for information on how to manage and deploy your fiber optics cabling, safety precautions, tips & tricks, and recommendations for creating complex fiber optic networks. You can find a copy of this document on the Support portal (see [Contact Us](#) on page 21).

Electromagnetic Compatibility



This equipment has been tested for verification of compliance with FCC Part 15, Subpart B requirements for Class A digital devices.

Notes

This equipment has been tested and found to comply with the limits for a Class A digital device, pursuant to part 15 of the FCC Rules. These limits are designed to provide reasonable protection against harmful interference when the equipment is operated in a commercial environment.

This equipment generates, uses, and can radiate radio frequency energy and, if not installed and used in accordance with the User Guide, may cause harmful interference to radio communications.

Operation of this equipment in a residential area is likely to cause harmful interference in which case the user will be required to correct the interference at their own expense.



This equipment has been tested and found to comply with the requirements of the EMC directive 2004/108/CE:

- EN 55022 Class A radiated and conducted emissions
- EN 55024 Immunity of Information Technology Equipment
- EN 61000-3-2 Harmonic current injection
- EN 61000-3-3 Limitation of voltage changes, voltage fluctuations and flicker
- EN 61000-4-2 Electrostatic discharge immunity
- EN 61000-4-3 Radiated electromagnetic field immunity – radio frequencies
- EN 61000-4-4 Electrical fast transient immunity
- EN 61000-4-5 Surge immunity
- EN 61000-4-11 Voltage dips, short interruptions and voltage variations immunity

Rattler 4 Operation

This chapter describes how the Rattler 4 system operates, including how to install the system and how to read the LEDs.

<i>Rattler 4 Single Unit Components</i>	10
<i>Rattler 4 Dual Unit Operation</i>	12
<i>Using the PicoLink pL-Tray to Rack Mount the Rattler 4</i>	13
<i>Fiber Optical Channel Monitoring using the LED Display</i>	14

Rattler 4 Single Unit Components

The Rattler 4 has no user adjustable components. The LED area provides monitoring once the connections are made and the unit is connected to power.

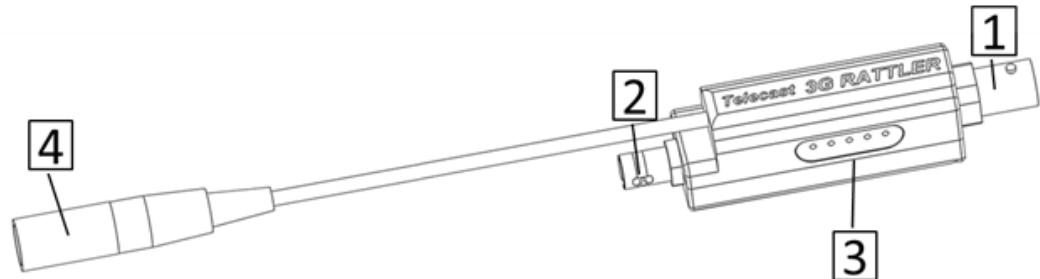

Fig. 2-1: Rattler 4 Single Unit

The Rattler 4 Single Unit features the following:

- 1 **BNC Connector:** HD/SDI Input for the Tx Unit and Output for the Rx Unit. Please see [Unpacking the Rattler 4](#) on page 7 for a list of supported signals.
- 2 **ST Fiber Connector**
- 3 **LED Display Area**
 - The Tx unit has a two LED Display
 - The Rx unit has a five LED DisplayPlease see below for detailed information on the LED display area.
- 4 **Mini-XLR Power Connector:** the connector is attached permanently to the Rattler 4 Unit and can be powered by the Grass Valley LKS-WSU Universal Power Supply or by any power supply with a Mini-XLR3F power connector. The Rattler 4 operates on 5-16 VDC.

Note: The Mini-XLR power connector is not compatible with previous 4-pin XLR power supplies.



Fig. 2-2: Power Supply and Connector

LED Display Operation

Rattler Tx Unit

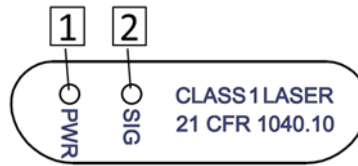

Fig. 2-3: Rattler Tx Unit LEDs

- 1 **Power LED** – indicates power is connected and within 5-16 VDC range
- 2 **SIG LED** – indicates HD/SDI Signal Presence

Rattler Rx Unit

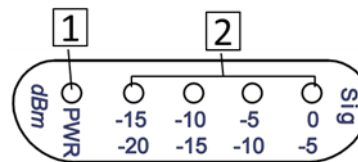
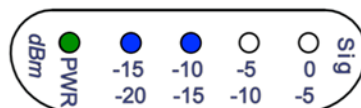

Fig. 2-4: Rattler Rx Unit LEDs

- 1 **Power LED** – indicates power is connected and within 5-16 VDC range
- 2 **Sig Strength LED Display** – indicates Received Optical Signal Strength from -20 dBm to 0 dBm

Fiber Optic Signal Strength measurement is explained further in [Fiber Optical Channel Monitoring using the LED Display](#) on page 14.

See below for examples of signal strength indications.



Two LEDs lit indicate a signal strength between -15 dBm and -10 dBm



Four LEDs lit indicate a signal strength between -5 dBm and 0 dBm

Fig. 2-5: LED indications

The Rattler 4 will indicate a non-standard temperature reading if the LEDs begin to blink all On and all Off.

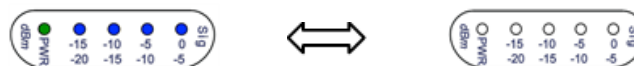

Fig. 2-6: non-standard temperature LEDs

If the Rattler unit internal temperature drops below -30 degrees C or above 65 degrees C, the blinking LED indicator will start. At these extreme temperatures, unit performance will be degraded or cease to function.

Rattler 4 Dual Unit Operation

Rattler 4 Dual Unit operation is nearly identical to that of the single units. The dual units have two independent LED displays, one on each side of the unit. Only one power supply is required.

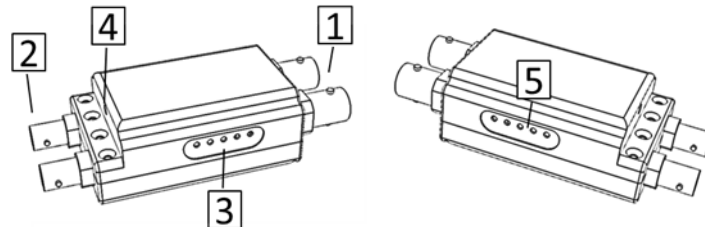

Fig. 2-7: Rattler 4 Dual Unit

1 Two BNC connectors

- The Dual TX unit has two BNC Inputs
- The Dual RX unit has two BNC Outputs
- The TR transceiver unit has one BNC Input and one BNC Output.

2 Two ST connectors

- The Dual TX unit has two ST Outputs
- The Dual RX unit has two ST Inputs
- The TR transceiver unit has one ST Input and one BNC Output

3 LED Display

- Two LEDs for TX Units
- Five LEDs for RX Units
- One of each type for Transceiver Units

4 Power Connection: the Pico-PA adapter allows the Rattler 4 to be used with standard 12V XLR power sources such as battery belt packs and power supplies (Mini-XLR Power connector and cable not shown for clarity).

- **LED Display:** second LED display on side opposite from first LED display (five or two LEDs depending on Rattler 4 model).

Using the PicoLink pL-Tray to Rack Mount the Rattler 4

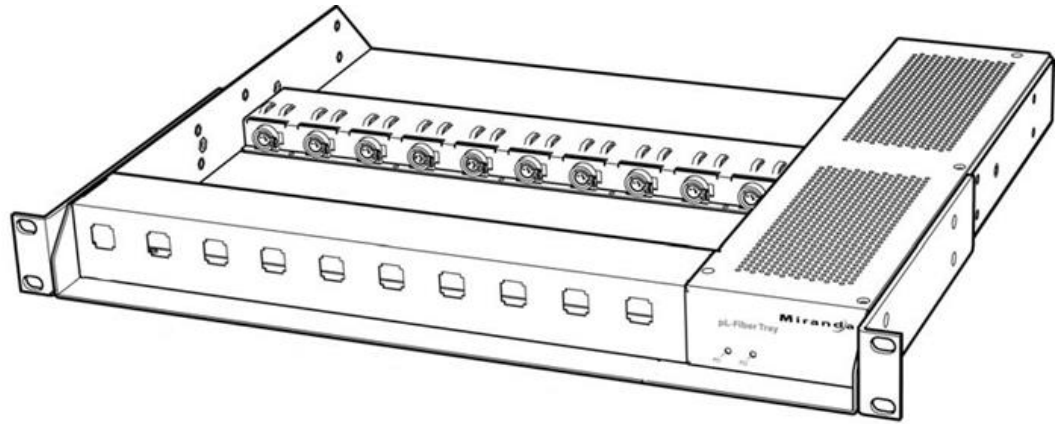

Fig. 2-8: PicoLink pL-Tray

The Rattler 4 and the Grass Valley PicoLink decoder product are the same physical size. This allows the use of certain PicoLink accessories with the Rattler 4.

The pL-Tray is a rack-mountable unit that can hold up to 10 Rattler 4 single units. The pL-Tray can provide redundant dual power supplies to ensure continuous Rattler operation.

Please see the Grass Valley, a Belden Brand web site www.miranda.com for additional information or contact your authorized Grass Valley reseller.

Fiber Optical Channel Monitoring using the LED Display

The Rattler 4 Rx receiver units provide direct digital readout of the Fiber Optic Link signal strength for signals received at the unit. This readout is presented in 5 dBm ranges of dBm units. Both the dB or decibel and the dBm or decibel referenced to one milliwatt.

The decibel (dB) is a logarithmic unit of measurement that expresses the magnitude of a physical quantity (usually power or intensity) relative to a specified or implied reference level. Since it expresses a ratio of two quantities with the same unit, it is a dimensionless, relative unit. A decibel is 1/10 of a bel, a seldom-used unit. Typically dB has been employed in Audio Measurement and Fiber Optics among many uses.

Proper measurement of signal strength requires an absolute measurement and the dBm provides this measurement. Since it is referenced to the milliwatt, it is an absolute unit, used when measuring absolute power. By comparison, the decibel (dB) is used for quantifying the ratio between two values, such as signal-to-noise ratio

The Rattler 4 operates within a defined range of Fiber Optic Link signal strength. The minimum recommended signal strength is -20 dBm or better. Typically the system should operate at levels between -8 dBm and -20 dBm. Cable length affects signal strength as does the number of connections between the two Rattler 4 units. Each connection, interconnect, or patch cable will produce a measurable signal loss that will contribute to decreasing the overall link optical loss margin and attainable distance.

The maximum fiber distance is defined by the optical loss margin. The RX signal must be -20 dBm or better. Losses on single mode fiber are approximately 0.5 dB/km or less. CWDM's account for about 5 dBm of loss per pair and must be considered when computing your link loss budget.

3

Best Practices

This chapter presents the Best Practices with the equipment as well as a Troubleshooting section.

<i>Best Practices</i>	16
<i>Troubleshooting</i>	16
<i>Block Diagram</i>	17

Best Practices

- Protect the Fiber Optic Cable and the Fiber Optic Connectors using the connector covers provided with the Rattler 4.
- **Always** keep these connectors protected unless they are being connected.
- You should read the **Using Fiber Optics Guide** for information on how to manage and deploy your fiber optics cabling, safety precautions, tips & tricks, and recommendations for creating complex fiber optic networks. You can find a copy of this document on the Support portal (see [Contact Us](#) on page 21).
- Once the system is set up and running, check the system display on the Rattler 4 for proper optical signal levels. Connections to the Rattler 4 must be in place in order for the LED display to function.
- Because the system is digital, the Signal Strength should fall within acceptable levels. When the Signal Strength is no longer strong enough, the signal stops.



Fig. 3-1: Rattler 4 Optical Power Indicators

Troubleshooting

Troubleshooting any technical issues with the Rattler 4 System is similar to any piece of television production gear with the obvious exception of the core Fiber Optic technology.

Here is a list of things to look out for and check:

- Check all your cables for any broken or bad connectors.
- Ensure that your Power Supply is connected and functioning.
- If using an external battery, ensure that it is fully charged.
- If you cannot resolve the problem in the field, contact support (see [Contact Us](#) on page 21).

Block Diagram

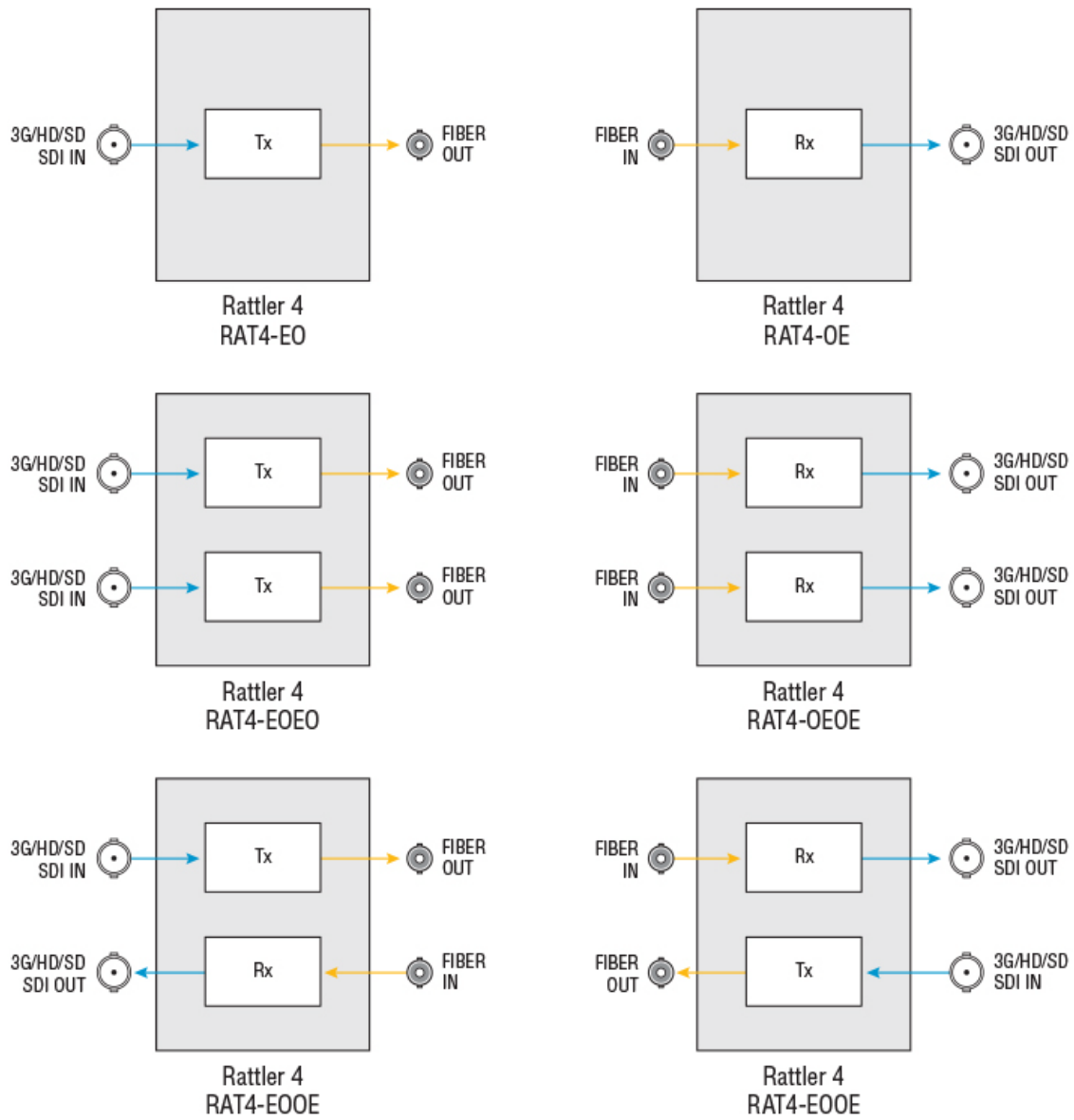

Rattler 4 Functional Block Diagram

Fig. 3-2: Rattler 4 Functional Block Diagram

4 Specifications

Video

Transmission Method.....	Digital
Input Level	800 mV (Peak To Peak)
Input Impedance	75 Ohms
Coaxial Equalization at 2.97 Gbps	3G 100m; HD 300m Belden 1694A
Output Impedance	75 Ohms
Bit-Error Rate at -22 dBm	10^{-11}
Jitter (pathological data pattern).....	<0.2 UI
Rise/fall times.....	<120 ps

Transmission

Operating Wavelength	1310 nm 1550 nm (WDM) or 1270-1610 nm (CWDM)
Coaxial video connector I/O	BNC
Optical Connector	ST
Optical Source	Laser Diode (FP or CWDM DFB)
Optical Detector.....	PIN-TIA diode
Transmitter Output	-7 (1330, 155nm), +3 dBm (CWDM)
Receiver Sensitivity	-22 dBm
Link Margin	typically 15dB / 20km (1330, 155nm), 25dB/50km (CWDM)
Fiber Type	Single-Mode

Mechanical/Environmental

Dimensions (WxHxD)	
Single Units.....	0.75 x 0.75 x 3.2 in
Dual Units.....	0.75 x 1.5 x 3.2 in
Weight (not including power supply)	3 oz
Input voltage.....	5-16 VDC
Power Connector.....	Plug replaceable, mini-XLR3m (Switchcraft Tini Q-G TA3MX or similar)
Power consumption (typical)	600 mW
Indicators.....	Power, signal, link, optical power
Temperature Range	-25° to 55 °C
Humidity Range	0 to 95 % non-condensing

Compliance

Laser Safety.....	Class 1 Laser
EMI/RFI.....	Complies with IEC/EN 60825-1
Certifications	RoHS



Grass Valley Technical Support

For technical assistance, please contact the Grass Valley Technical Support center nearest you:

Americas

Office hours: 9:00 a.m. – 9:00 p.m. (EST)
Telephone: 1-800-224-7882
Fax: +1 514 335 1614
E-mail: support@miranda.com

Asia

Office hours: 9:00 a.m. – 6:00 p.m. (GMT+8)
Telephone: +852 2539 6987
Fax: +852 2539 0804
E-mail: asiotech@miranda.com

Europe, Middle East, Africa, UK

Office hours: 9:00 a.m. – 6:00 p.m. (GMT)
Telephone: +44 118 952 3444
Fax: +44 118 952 3401
E-mail: eurotech@miranda.com

China

Office hours: 9:00 a.m. – 6:00 p.m. (GMT+8)
Telephone: +86 10 5873 1814
E-mail: asiotech@miranda.com

France

Office hours: 9:00 a.m. – 5:00 p.m. (GMT+1)
Telephone: +33 1 55 86 87 88
Fax: +33 1 55 86 00 29
E-mail: eurotech@miranda.com

Malaysia

Telephone: +60 3 2247 1808

EMERGENCY After Hours (Global)

Toll Free: 1-800-224-7882 (US and Canada)
Telephone: +1 514 333 1772

Corporate Head Office

Grass Valley
3499 Douglas-B.-Floreni
St-Laurent, Quebec H4S 2C6
Canada
Telephone: +1 514 333 1772
Fax: +1 514 333 9828
Web: www.miranda.com