

Telecast Fiber Solutions

TelePort 3G/10G User Guide

M4039-9900-103

17 January 2018



Copyright & Trademark Notice

Copyright © 2008–2018, Grass Valley. All rights reserved.

Belden, Belden Sending All The Right Signals, and the Belden logo are trademarks or registered trademarks of Belden Inc. or its affiliated companies in the United States and other jurisdictions. Grass Valley, TelePort 3G/10G are trademarks or registered trademarks of Grass Valley. Belden Inc., Grass Valley, and other parties may also have trademark rights in other terms used herein.

Terms and Conditions

Please read the following terms and conditions carefully. By using TelePort 3G documentation, you agree to the following terms and conditions.

Grass Valley, a Belden Brand (“Grass Valley”) hereby grants permission and license to owners of TelePort 3G to use their product manuals for their own internal business use. Manuals for Grass Valley products may not be reproduced or transmitted in any form or by any means, electronic or mechanical, including photocopying and recording, for any purpose unless specifically authorized in writing by Grass Valley.

A Grass Valley manual may have been revised to reflect changes made to the product during its manufacturing life. Thus, different versions of a manual may exist for any given product. Care should be taken to ensure that one obtains the proper manual version for a specific product serial number.

Information in this document is subject to change without notice and does not represent a commitment on the part of Grass Valley.

Warranty information is available in the Support section of the Grass Valley Web site (www.miranda.com).

Title	TelePort 3G User Guide
Part Number	M4039-9900-103
Revision	17 January 2018

toc

Table of Contents

1 About TelePort 3G/10G	5
About the TelePort 3G/10G System	6
Fiber Cable Overview	7
Safety and Fiber Optic Systems	8
Unpacking the TelePort 3G/10G	8
Optical Fiber Safety	8
FCC Part A Manual Notice	8
Product Returns	9
2 Hardware and Block Diagrams	11
Available Models	12
Block Diagrams	14
3 TelePort 3G/10G Components	17
TelePort 3G/10G Front Panel Features	18
Power and Display Panel	18
TelePort 3G Transmitter	18
Area A – SDI/DATA IN	19
TelePort 3G Receiver	19
Area A – SDI/DATA OUT	19
TelePort 3G/10G Transceiver	20
Area A – SDI/DATA IN	20
Area B – SDI/DATA OUT	20
TelePort 3G/10G Rear Panel Features	22
Area A - Rear Panel Power Connectors	22
Redundant Power Supply Usage	23
Power Connector Wiring	23
Area B – CAN BUS Connector	23
Area C – The ST Fiber Connectors	23
Fiber ADAP Power Supplies	25
4 TelePort 3G/10G Operation	27
Fiber Optical Channel Monitoring	28
Using the TelePort 3G/10G Optical Measurement Display	29
TelePort 3G/10G Optical Measurement Display	29
TelePort 3G Technical Information Display	29
Teleport 10G Technical Information Display	30
System Firmware Display	31
Best Practices	32

Troubleshooting	32
5 TelePort 3G/10G Models and Part Numbers	33
Part Numbers	34
Part Number Card Options.....	34
Fiber I/O Cards	34
Example TelePort 3G/10G Models.....	35
Model TP3-MNPP-W8W8	35
Model TP3-MNQU-W16.....	35
Model TP3-PPPP-W16	35
6 Specifications	37



About TelePort 3G/10G

This chapter provides an overview of the TelePort 3G/10G and includes the safety and warranty information about it.

<i>About the TelePort 3G/10G System</i>	6
<i>Safety and Fiber Optic Systems</i>	8
<i>Product Returns</i>	9

About the TelePort 3G/10G System

The TelePort is a CWDM multiplexer. It takes in optical signals within the 1200nm to 1670nm optical window, receives those signals, does an optical to electrical conversion, re-transmits them (electrical to optical) on distinct wavelengths, and then multiplexes them using a CWDM optical multiplexer onto one fiber. This results in up to 16 signals per fiber.

The TelePort is available in three versions:

- **Version 1:** supports 16 channels of transmission over a single fiber and pairs with a 16 channel receiver at the other end of the fiber link.
- **Version 2:** transmits eight channels and receives eight channels over two fibers (one fiber for each direction) and pairs with an identical model at the other end.
- **Version 3:** sends eight signals and receives eight signals using only one fiber and requires different models for each end of the link.

In all models, single mode fiber is required.

The optical signal that you supply to the TelePort must be digital and must be 3 Gb/s or 10 Gb/s IP. There is no requirement that this optical signal originate from a Grass Valley product.

The TelePort 3G/10G provides LEDs to indicate the presence of a Fiber optic signal at each front panel ST Fiber Input Connector. The TelePort 3G/10G features an integrated optical power meter for monitoring received optical power and other system parameters.

The TelePort 3G/10G also features dual 12 to 18 VDC power inputs for electrical redundancy.

In [Figure 1-1](#), a 16 Channel TelePort 3G/10G Transmitter is connected to a 16 Channel TelePort 3G/10G Receiver. Half of the total capacity connects to a remote set of production cameras to the central control center. The open eight channels can be used for audio or data feeds, as well as video monitoring feeds.

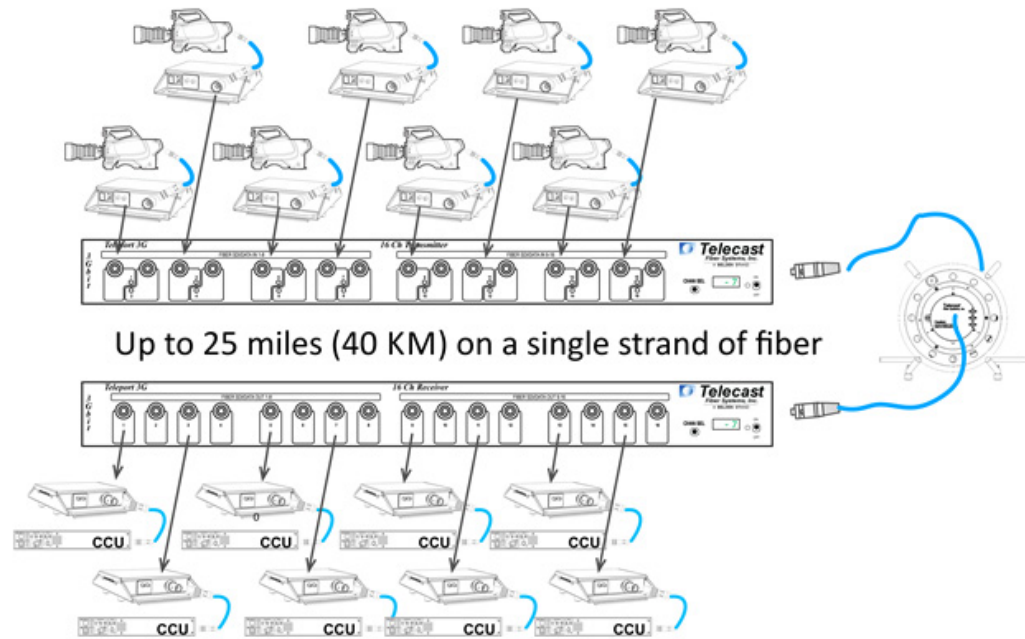

Fig. 1-1: Possible uses for the TelePort 3G/10G

Fiber Cable Overview

Fiber Optics and Fiber Optic Cable are the core technologies at the heart of the TelePort 3G/10G system. The ability to multiplex and de-multiplex multiple ranges of fiber optic signals carrying SDI, Audio, and Data is what enables the TelePort 3G/10G. The specific theory and operation of Fiber Optics is beyond the scope of this document.

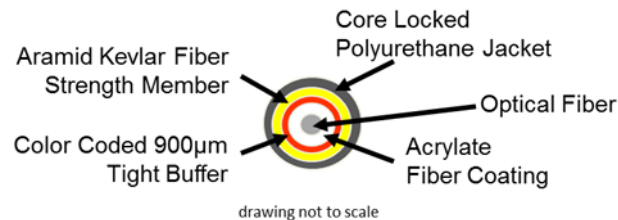

Fig. 1-2: Single Mode Fiber Optic Cable Cross-Section

Safety and Fiber Optic Systems

Unpacking the TelePort 3G/10G

Please consult your packing slip and purchase order to ensure that you have received all of the expected components.

Inspect all components for scratches and other mechanical damage, and inspect the electrical connectors for bent or damaged pins and latches. Report any missing or damaged components to Grass Valley (see [Product Returns](#) on page 9).

Leave the protective caps on the optical connectors whenever the fiber is disconnected.

Optical Fiber Safety

Never look directly into the end of the optic fiber while either end of the system is operating.

This TelePort 3G/10G contains CDRH Class 1 laser devices. To prevent damaging your eyes, always avoid looking directly at, or staring into, the laser light located on an optical connector or on the end of a fiber.

Infrared radiation is produced at the fiber connection port on the rear of the TX units and at the end of any un-terminated optical fibers that are attached to this port. Avoid any direct exposure to the light that comes from these sources.

Do not power up the unit when no fiber connector is attached to the fiber port.

There are no manual adjustments to be made inside the TelePort 3G/10G. Do not attempt to perform any type of service to this instrument other than any as instructed in this User Guide. Refer all servicing to Grass Valley, a Belden Brand.

Always use cable connector caps when the cables are not connected. This protects the connector from damage and the unlikely event of exposure to an operating optical link. Keeping the caps in place when the connectors are not in use will prevent dirt and dust from entering the connector and degrading the performance of the optical link.

FCC Part A Manual Notice



This equipment has been tested and found to comply with the limits for a Class A digital device, pursuant to part 15 of the FCC rules. These limits are designed to provide reasonable protection against harmful interference when the equipment is operated in a commercial environment.

This equipment generates, uses and can radiate radio frequency (RF) energy and, if not installed and used in accordance with this User Guide, it may cause harmful interference to radio communications.

Product Returns

In the unlikely event of damage to your TelePort 3G/10G during shipping or delivery please note the damage with the delivery or shipping service and document the packaging and product where you see damage. If any component does not work correctly out of the box please contact Grass Valley support (see [Contact Us](#) on page 38).

If the problem cannot be remedied through a service telephone call, you will receive an RMA number (Return of Merchandise Authorization). Please note this RMA number inside and outside of all shipping boxes and on all documentation provided with the items to be returned.

Hardware and Block Diagrams



This chapter lists the models available with the TelePort 3G/10G and lists the block diagrams of these models.

<i>Available Models</i>	12
<i>Block Diagrams</i>	14

Available Models

The TelePort 3G/10G is available in a variety of standard models. The following list covers the models available at the time of publication.

The TelePort 3G/10G comes in six models. The four Transceiver types have identical front panels and vary only on the rear panel depending on their Fiber Optic I/O configuration. Each Transmitter and Receiver type have their own unique model numbers.

Part Number	Type	SDI/DATA Transmit	SDI/DATA Receive	Number of Fibers	Used With (Complementary Unit)
TP3-MNPP-W8W8	Transceiver	8	8	2	TP3-MNPP-W8W8
TP3-MNPP-W16	Transceiver	8	8	1	TP3-QUPP-W16
TP3-QUPP-W16	Transceiver	8	8	1	TP3-MNPP-W16
TP3-MNQU-W16	Transmitter	16	0	1	TP3-PPPP-W16

Part Number	Type	SDI/DATA Transmit	SDI/DATA Receive	Number of Fibers	Used With (Complementary Unit)
TP3-PPPP-W16	Receiver	0	16	1	TP3-MNQU-W16
TP3-BCPP-W8W8	Transceiver	8	8	2	TP3-BCPP-W8W8

Typically the TelePort 3G/10G systems are used in pairs as follows:

- The TP3-MNPP-W8W8 is used with another TP3-MNPP-W8W8
- The TP3-MNPP-W16 is used with a TP3-QUPP-W16
- The TP3-MNQU-W16 is used with a TP3-PPPP-W16
- The TP3-BCPP-W8W8 is used with another TP3-BCPP-W8W8

For diagrams of these systems, see [Block Diagrams](#) on page 14.

However, it is possible to also use a TelePort 3G/10G on one end and another device (such as a Grass Valley CWDM) and various electrical-optical media, the Telecast-series Python, or a Telethon. Please consult with Grass Valley sales engineering or support for assistance with such configurations (see [Contact Us](#) on page 38).

Block Diagrams

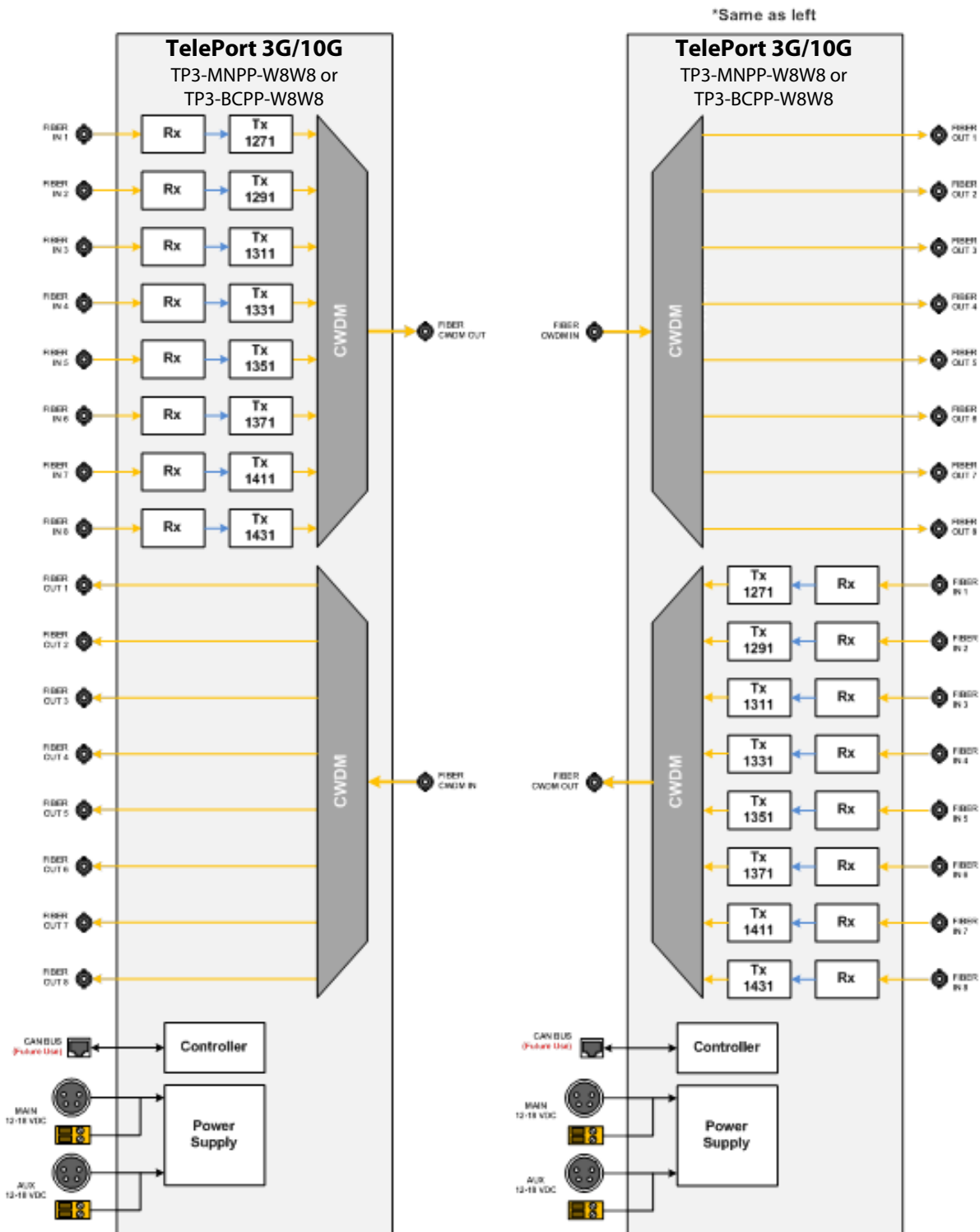

Fig. 2-1: 8x8 Channels TelePort 3G/10G on 2 Fibers Block Diagram

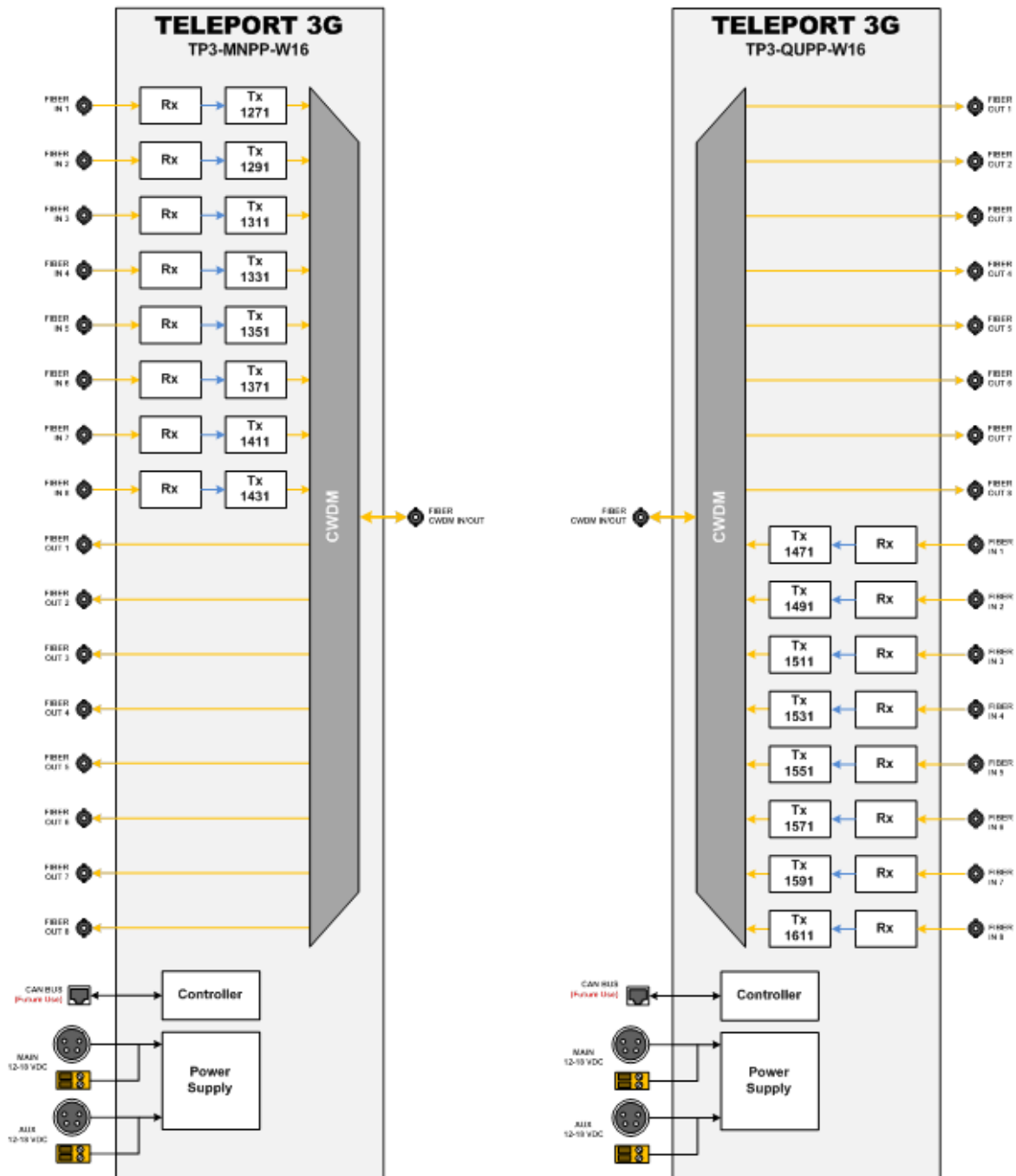

Fig. 2-2: 8x8 Channels TelePort 3G on 1 Fiber Block Diagram

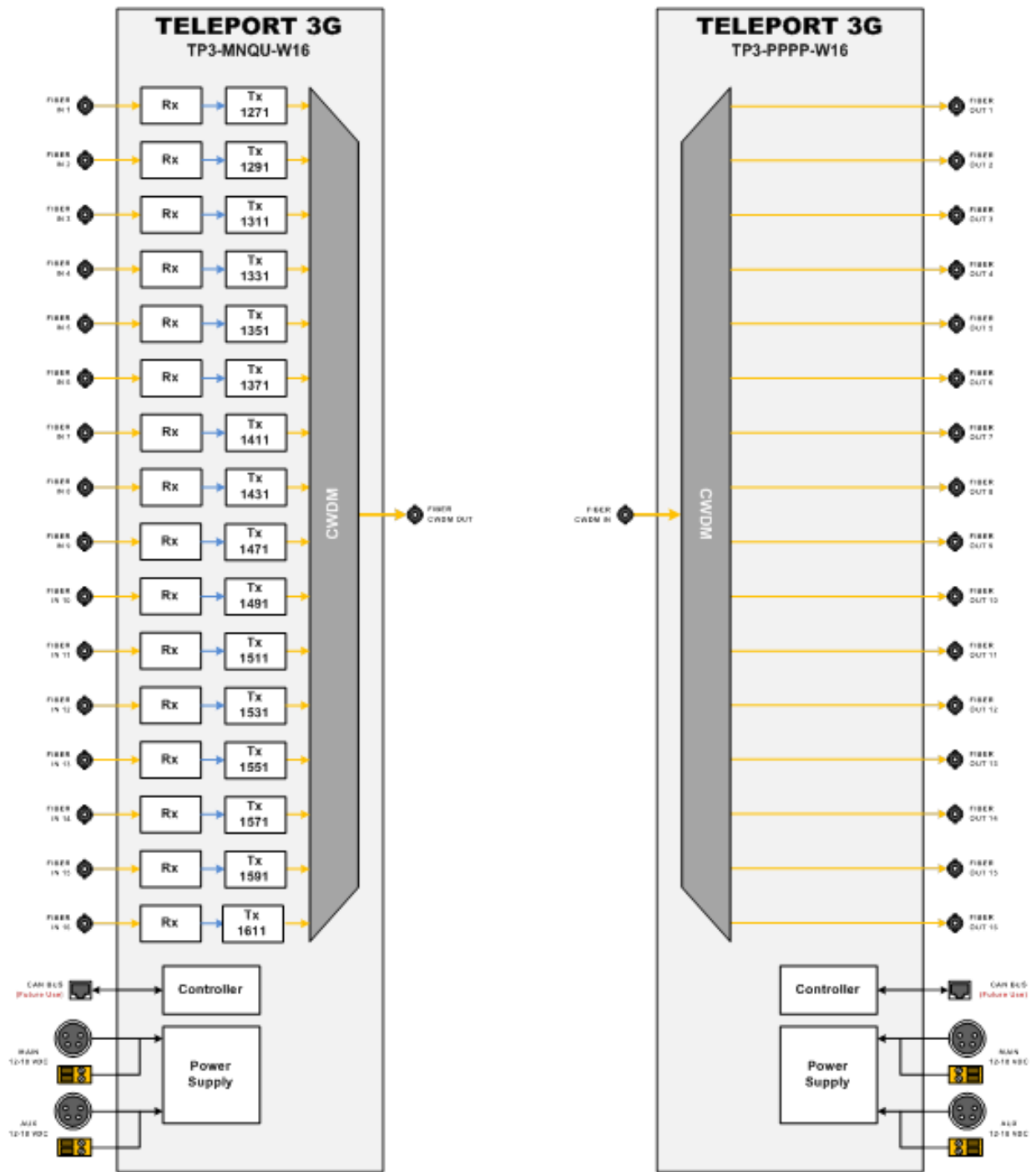

Fig. 2-3: 16 Channel TelePort 3G on 1 Fiber Block Diagram

TelePort 3G/10G Components



This chapter describes the main components of the TelePort 3G/10G.

<i>TelePort 3G/10G Front Panel Features</i>	18
<i>TelePort 3G/10G Rear Panel Features</i>	22
<i>Fiber ADAP Power Supplies</i>	25

TelePort 3G/10G Front Panel Features

The TelePort 3G/10G is used as a set of two units. The inputs to one unit of the pair are received by the second unit and appear at the corresponding outputs.

For example, transmitter inputs 1-8 and 9-16 are reflected on the receiver as Outputs 1-8 and 9-16.

Transceivers work identically in either direction with Inputs 1-8 reflected as Outputs 1-8 on the opposite unit.

There is no requirement that all connectors be active. For example, fiber Inputs 1 and 3 are used, while Input 2 is skipped, the output on the opposite unit will be on Output 1 and 3.

The TelePort 3G/10G provides no user accessible adjustments. The unit is a pass-through device with selectable monitoring capability.

Power and Display Panel

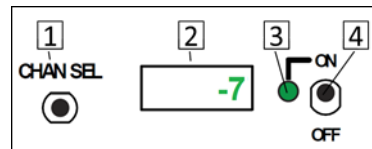

Fig. 3-1: Power and Display features

The Power and Display Area has four features:

- **CHAN SEL** – scrolls the LED display through each of the Fiber Channels
- **Digital Display** – display optical power levels, unit firmware and operating temperature
- **Power Monitor LED** – indicates Power Status
 - **Red:** standby (power applied to rear connectors but unit not switched on)
 - **Green:** unit switched on
- **On/Off Switch** – controls power to the TelePort 3G/10G unit

TelePort 3G Transmitter

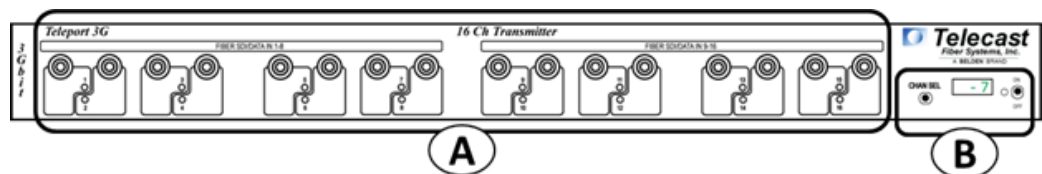

Fig. 3-2: TelePort 3G Transmitter Front Panel

The TelePort 3G Transmitter Front Panel has two features:

- **A - SDI/Data In** - see [Area A – SDI/DATA IN](#) on page 19
- **B - Power & Display Area** - see [Power and Display Panel](#) on page 18

Area A – SDI/DATA IN

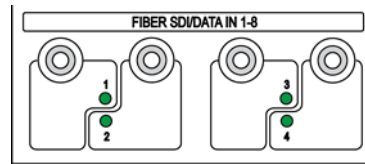

Fig. 3-3: SDI/DATA Input ports

The TelePort 3G Transmitter has up to 16 Fiber Channel SDI/DATA Input ST connectors on the front panel. All inputs operate identically and are multiplexed for transmission on the fiber output of the unit. The Fiber signals are demultiplexed in the receiving unit and appear on the corresponding ST outputs.

The Fiber connections can carry a digital optical signal with a data rate of 3 Gb/s.

Each front panel Fiber input has an LED monitor that indicates the following:

- **Green:** fiber optic connection present with active SDI signal
- **Red:** no optical connection detected or the active optical signal level has fallen below -22 dBm to signify signal loss

TelePort 3G Receiver

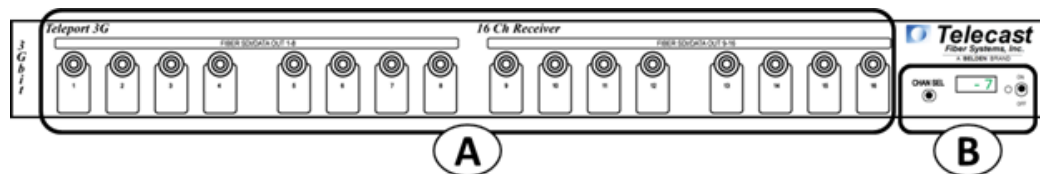

Fig. 3-4: TelePort 3G Front Panel

The TelePort 3G Receiver Front Panel has two features:

- **A - SDI/Data Out** - see [Area A – SDI/DATA OUT](#) on page 19
- **B - Power & Display Area** - see [Power and Display Panel](#) on page 18

Area A – SDI/DATA OUT

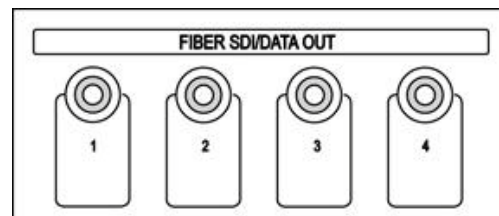

Fig. 3-5: 4 SDI/DATA Output ST Connectors

The TelePort 3G Receiver and Transceiver have up to 16 Fiber Channel SDI/DATA Output ST connectors on the front panel. All Outputs operate identically and are demultiplexed from the signals received from the sending unit.

- The Fiber connections can carry a digital optical signal with a data rate of 3 Gb/s.
- The Fiber outputs do not have associated LED indicators

TelePort 3G/10G Transceiver

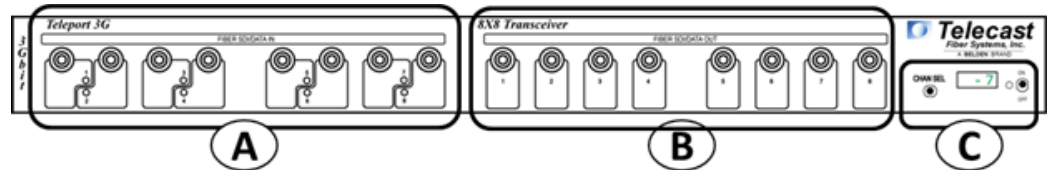

Fig. 3-6: TelePort 3G/10G Transceiver Front Panel

The TelePort 3G/10G Transceiver Front Panel has three features:

- **A - SDI/Data In** - see [Area A – SDI/DATA IN](#) on page 20
- **B - SDI/Data Out** - see [Area B – SDI/DATA OUT](#) on page 20
- **C - Power & Display Area** - see [Power and Display Panel](#) on page 18

Area A – SDI/DATA IN

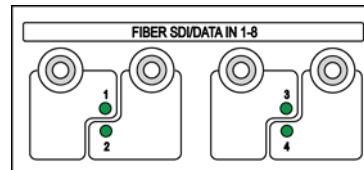

Fig. 3-7: 4 SDI/DATA In ST Connectors

The TelePort 3G/10G Transceiver has eight Fiber Channel SDI/DATA Input ST connectors on the front panel. All inputs operate identically and are multiplexed for transmission on the fiber output of the unit. The Fiber signals are demultiplexed in the receiving unit and appear on the corresponding ST outputs.

The Fiber connections can carry a digital optical signal with a data rate of 3 Gb/s or 10 Gb/s IP according to the TelePort 3G/10G model.

Each front panel Fiber input has an LED monitor that indicates the following:

- **Green:** fiber optic connection present with active SDI signal
- **Red:** no optical connection is detected or the active optical signal level is below -22 dBm for 3 Gb/s signals or -14 dBm for 10 Gb/s signals to signify signal loss

Area B – SDI/DATA OUT

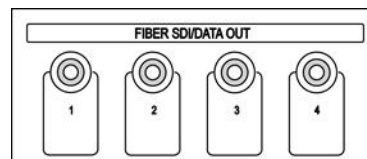

Fig. 3-8: 4 SDI/DATA Output ST Connectors

The TelePort 3G/10G Transceiver has eight Fiber Channel SDI/DATA Output ST connectors on the front panel. All Outputs operate identically and are demultiplexed from the signals received from the sending unit.

- The Fiber connections can carry a digital optical signal with a data rate of 3 Gb/s or 10 Gb/s IP according to the TelePort 3G/10G model. See also [Teleport 10G Technical](#)

[Information Display](#) on page 30.

- The Fiber outputs do not have associated LED indicators

TelePort 3G/10G Rear Panel Features

The TelePort 3G/10G illustration is repeated for ease of use of this guide. All TelePort 3G/10G units operate the same: the only difference is in whether the Fiber Optic ST connectors are inputs or outputs.



Fig. 3-9: TelePort 3G/10G Rear Panel

Area A - Rear Panel Power Connectors

The TelePort 3G/10G is designed to use redundant 12 to 18 Volts DC power supplies (MAIN and AUX). A battery backup option is not provided for the TelePort 3G/10G unit.

Power can be supplied to the unit by either a 4 pin XLR connector from an external power supply such as a ADAP-AC-04 or with direct wiring from a 12 to 18 Volt DC power supply connected to the provided terminal block.

Do not connect two power supplies through both the XLR connector and the terminal block at the same time for either the MAIN or AUX inputs (for example, do not connect two separate power supplies to inputs 1 and 2, or to inputs 3 and 4 in the figure below). However, the MAIN power supply can use one connector type (XLR or direct wire) while the AUX power supply can use the other connector type (for example, you can connect two separate power supplies to inputs 1 and 4, or to inputs 2 and 3 in the figure below).

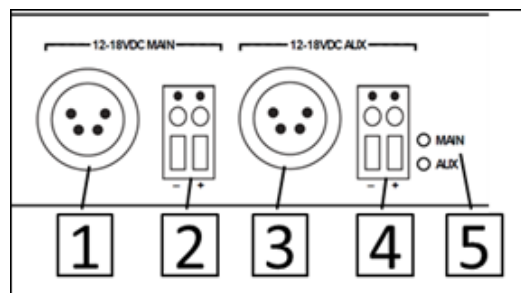

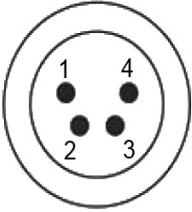

Fig. 3-10: Rear Panel Power Connectors

- **1 & 2 – Connectors for the MAIN 12 to 18 VDC power supply** (XLR and Direct wire terminal block)
- **3 & 4 – Connectors for the AUX 12 to 18 VDC power supply** (XLR and Direct wire terminal block)
- **5 – MAIN/AUX Indicator LEDs** – the LED for each power supply will be Green if power is being applied to the TelePort 3G/10G. If both MAIN and AUX are connected to a power source, both LEDs will be Green. A lit LED is not an indication of which power source is being used at the time: only that the power source is currently available.

Redundant Power Supply Usage

The TelePort 3G/10G power supply contains circuitry to detect which of the power sources (MAIN or AUX) is producing the highest voltage and then uses that source to power the unit. If the power sources are about the same voltage, then the TelePort 3G/10G uses power from both.

Power Connector Wiring

Figure	Pin	Function
	1	Ground
	2	Unused
	3	Unused
	4	+ Power 12 VDC
This matching connector is from either an ADAP-AC-04 power supply unit or a customer-supplied 12 to 18 VDC power supply		
	1	Minus Voltage Terminal
	2	Plus Voltage Terminal

Area B – CAN BUS Connector

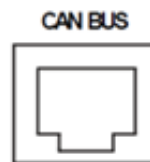

Fig. 3-11: CAN BUS connector

The CAN BUS connector is inactive in this version of the TelePort 3G/10G. It may be used for system monitoring in the future.

CAN is (Communication Area Network) is a protocol designed to support the monitoring of microcontrollers.

Area C – The ST Fiber Connectors

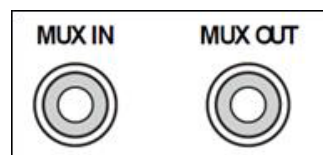

Fig. 3-12: MUX IN and OUT connectors

The MUX IN connector receives up to eight or 16 channels depending on whether the unit is a Transceiver or Receiver.

Conversely the Transceiver or Transmitter MUX OUT connector sends the up to eight or 16 channels to the opposite TelePort 3G/10G unit.

Fiber ADAP Power Supplies

The TelePort 3G/10G requires a power supply providing 12 to 18 volts at 1.5 Amps. The power supply recommended for this unit is the ADAP-AC-04-X (X: the specific geography required). You can use any power supply meeting the required specification and providing power through an XLR-4 Female connector. Please contact Grass Valley (see [Contact Us](#) on page 38) or your Grass Valley dealer for more information.

You can also use direct wire power connections from a customer provided power source with the Terminal Block power connections located on the back panel.



Fig. 3-13: Power Supply

The ADAP-AC-04 is supplied with a 4PIN XLR/A4F connector for the power plug on the TelePort 3G/10G unit.

4 TelePort 3G/10G Operation

This chapter describes the operation of the TelePort 3G/10G. Please keep in mind that once the system is properly set up and configured, there is very little to do during normal operation.

<i>Fiber Optical Channel Monitoring</i>	28
<i>Using the TelePort 3G/10G Optical Measurement Display</i>	29
<i>Best Practices</i>	32
<i>Troubleshooting</i>	32

Fiber Optical Channel Monitoring

The TelePort 3G/10G provides direct digital readout of the Fiber Optic Link signal strength for signals received at the unit's front panel. This readout is presented in units of dBm. It is useful to understand the difference between the dB or decibel and the dBm or decibel referenced to one milliwatt.

The decibel (dB) is a logarithmic unit of measurement that expresses the magnitude of a physical quantity (usually power or intensity) relative to a specified or implied reference level. Since it expresses a ratio of two quantities with the same unit, it is a dimensionless, relative unit. A decibel is one tenth of a bel, a seldom-used unit. Typically dB has been employed in Audio Measurement and Fiber Optics among many other uses.

Proper measurement of signal strength requires an absolute measurement and the dBm provides this measurement. Since it is referenced to the milliwatt, it is an absolute unit, used when measuring absolute power. By comparison, the decibel (dB) is used for quantifying the ratio between two values, such as signal-to-noise ratio.

The TelePort 3G/10G operates within a defined range of Fiber Optic Link signal strength. The minimum recommended input signal strength at the front panel is -20 dBm or better for 3Gb/s and -14 dBm or better for 10 Gb/s. Typically the system should operate at levels between -8 dBm and -20/-14 dBm. The standard laser output strength is -6 dBm. Cable length affects signal strength as does the number of connections between the two TelePort 3G/10G units. Any use of repeaters or cable bulkhead connector will produce a minimal signal loss through each connection.

The rear panel optical output from each transmitter is generated by an infrared laser diode that is coupled to a CWDM and onto the fiber. User connections on the TelePort 3G/10G are made at the bulkhead ST type connectors on the front and rear panels. Operation is intended for use on single mode fiber. Since the CWDM output of the Teleport is the aggregate output of all 8 or 16 optical transmitters inside the frame, the total optical power output on a single fiber optic cable will be in the +4 to +8 dBm range. Standard practice of NEVER looking directly into a fiber should be followed at all times.

Using the TelePort 3G/10G Optical Measurement Display

The optical measurement functionality is similar across all four types of TelePort 3G/10G. A transceiver, transmitter and receiver work identically with one exception. The system reports fiber optical strength only for fiber optic signals received at a unit's front panel. Transmission strength is not measured.

TelePort 3G/10G Optical Measurement Display

The TelePort 3G/10G optical signal strength display shows characteristics for the TelePort 3G/10G Transmitter, Receiver, and Transceiver.

The Channel Select switch is a dual function switch:

- Flicking to the right allows scrolling through the individual channels to provide basic status on the signal.
- Flicking to the left provides additional information about the current channel such as front panel input optical power signal strength.



Fig. 4-1: Flicking the CHAN SEL switch

Scroll through the signal channels by flicking the switch to the right. The system reports on the installed SDI channels and the installed fiber channels being transmitted by the unit.

In a 8 x8 Transceiver, the CHAN SEL switch will display the eight Transmit channels first followed by the eight Receive Channels.

After the last channel, the display will show the current ambient temperature within the unit chassis in degrees Celsius.

After each flick, the display will indicate the monitored channel such as TPx01 or TPx02. For each TX channel, you can flick the switch to the left to display Technical Information about the channel such as front panel input optical power signal strength in dBm.

TelePort 3G Technical Information Display

Flicking the CHAN SEL switch to the left provides additional technical information that identifies the specific physical channel that is being measured. This information is presented in scrolling format four characters wide.

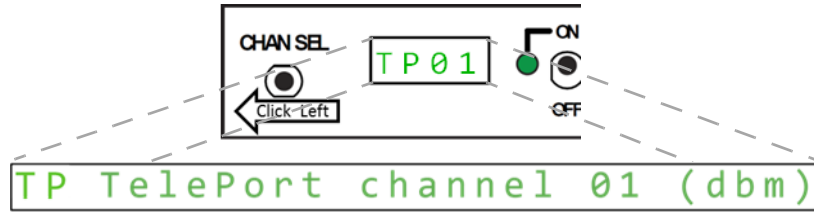

Fig. 4-2: TelePort 3G Technical Information display

Front panel Receive Channels are not monitored by the TelePort 3G unit.

Teleport 10G Technical Information Display

Flicking the CHAN SEL switch to the left provides additional technical information that identifies the specific physical channel that is being measured. This information is presented in scrolling format four characters wide. DISP in the figure below shows the reading on the unit's built-in display. LED is the color of the front panel LED for each input channel.

dBm	DISP	LED
>0	OVL!	Green
0	0	Green
-1	-1	Green
-2	-2	Green
-3	-3	Green
-4	-4	Green
-5	-5	Green
-6	-6	Green
-7	-7	Green
-8	-8	Green
-9	-9	Green
-10	-10	Green
-11	-11	Green
-12	-12	Green
-13	-13	Green
-14	-14	Green
-15	LOW	Green
-16	LOW	Green
-17	LOW	Green
-18	LOW	Green
-19	LOS	Red
-20	LOS	Red

OVL!: Overload

LOS: Loss Of Signal

Fig. 4-3: TelePort 10G Technical Information display

Front panel Receive Channels are not monitored by the TelePort 10G unit.

System Firmware Display

The TelePort 3G/10G display will display the current firmware version when the unit is powered on. This appears in the display as a scrolling series of alphanumeric character four characters wide.

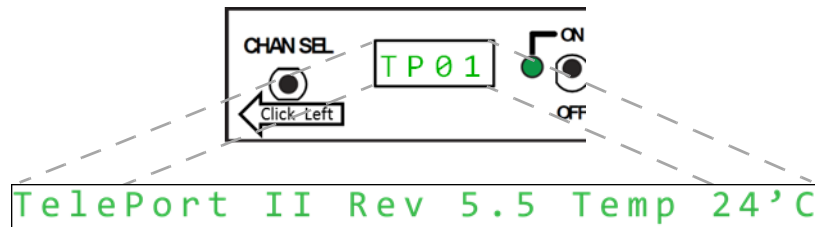

Fig. 4-4: Firmware display

Best Practices

- Take care around the laser equipment to avoid the possibility of eye damage
- Protect the Fiber Optic Cable and the Fiber Optic Connectors. **Always** keep these capped unless they are connected.
- Read the **Using Fiber Optics Guide** for information on how to manage and deploy your fiber optics cabling, safety precautions, tips & tricks, and recommendations for creating complex fiber optic networks. You can find a copy of this document on the Support portal (see [Contact Us](#) on page 38).
- Make sure that the TelePort 3G/10G unit is secure and cannot be inadvertently moved or kicked about. The units may usually be rack-mounted and therefore safe and secure but in instances where it must be used in “table top” operation ensure that the connectors on both the front and rear panes cannot be damaged by being inadvertently struck or pulled.
- Secure the power supplies and power connections to ensure power is continuous.
- Once the system is set up and running, do not ignore the system display monitor on the TelePort 3G/10G.
- The system is digital, so the Signal Strength will either meet or exceed the requirements. When it is no longer strong enough, the signal simply cuts off.
- Be as careful during System tear down as during System setup.

Troubleshooting

Troubleshooting any technical issues with the TelePort 3G/10G System is similar to any piece of television production gear with the obvious exception of the core Fiber Optic technology.

Here is a list of things to look out for:

- Check all your cables for any broken connections or bad connectors.
- Ensure that the Power Supply is working.
- If you cannot resolve the problem in the field, contact Grass Valley Support (see [Contact Us](#) on page 38).

5

TelePort 3G/10G Models and Part Numbers

This chapter explains how to decode the TelePort 3G/10G Part Number. Sample part numbers are decoded at the end of this section.

<i>Part Numbers</i>	34
<i>Example TelePort 3G/10G Models</i>	35

Part Numbers

The TelePort 3G/10G part number consists of three sections as described below:

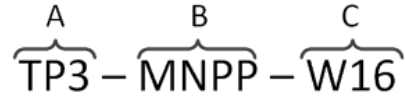

Fig. 5-1: TelePort 3G/10G part number

- **A - The product designation** – in this case TP3 stands for TelePort 3G/10G
- **B - Channel Card Options** – the four letters correspond to the four available slots. If a position has “0” than the slot is empty. The available card options are listed below.
- **C - Fiber I/O Options** – the number indicates the number of fiber optic channels. The I/O options are listed below.

Part Number Card Options

All cards have four channels.

Code Letter	Usage	Type	Wavelength
M	Transmit	CWDM	1310 Low Range: 1271, 1291, 1311, 1331 nm
N	Transmit	CWDM	1310 High Range: 1351, 1371, 1411, 1431 nm
Q	Transmit	CWDM	1550 Low Range: 1471, 1491, 1511, 1531 nm
U	Transmit	CWDM	1550 High Range: 1551, 1571, 1591, 1611 nm
B	Transmit	CWDM	1310 Low Range: 1271, 1291, 1311, 1331 nm
C	Transmit	CWDM	1310 High Range: 1351, 1371, 1411, 1431 nm
P	Receive	Demux Leads Only	Straight Through Connectors

Fiber I/O Cards

Desig.	Usage	Type	Wavelength
W8	Receive or Transmit	1 – Fiber I/O – 8 channels	CWDM
W16	Receive or Transmit	1 – Fiber I/O – 16 channels	CWDM

Example TelePort 3G/10G Models

Model TP3-MNPP-W8W8

Model TP3-MNPP-W8W8 Transceiver with eight Transmit Channels and eight Receive Channels with CWDM and 2 Fibers I/O		
Position	Item	Description
Card Slot #1	M	CWDM Multiplexer 1310 nm Low Range
Card Slot #2	N	CWDM Multiplexer 1310 nm High Range
Card Slot #3	P	Four Straight Through Connectors
Card Slot #4	P	Four Straight Through Connectors
I/O #1	W8	8 Channel Fiber I/O Card
I/O #2	W8	8 Channel Fiber I/O Card

Model TP3-MNQU-W16

Model TP3-MNQU-W16 Transmitter with 16 Channels equipped with CWDM and single Fiber I/O		
Position	Item	Description
Card Slot #1	M	CWDM Multiplexer 1310 nm Low Range
Card Slot #2	N	CWDM Multiplexer 1310 nm High Range
Card Slot #3	Q	CWDM Multiplexer 1550 nm Low Range
Card Slot #4	U	CWDM Multiplexer 1550 nm High Range
I/O #1	W16	16 Channel Fiber I/O Card
I/O #2		NA

Model TP3-PPPP-W16

Model TP3-PPPP-W16 – Receiver with 16 Channels equipped with CWDM and single Fiber I/O		
Position	Item	Description
Card Slot #1	P	Four Straight Through Connectors
Card Slot #2	P	Four Straight Through Connectors
Card Slot #3	P	Four Straight Through Connectors
Card Slot #4	P	Four Straight Through Connectors
I/O #1	W16	16 Channel Fiber I/O Card
I/O #2		NA

6 Specifications

Transmitter Inputs

Interface: Digital optical
Input wavelength range: 1250 to 1650 nm
Input optical power range:
 3Gb/s..... -2 to -22 dBm
 10Gb/s -2 to -14 dBm
Input optical connector: ST
Maximum data rate, per channel: 3 Gb/s or 10 Gb/s

Transmitter Output

Interface:..... Digital optical, CWDM
Output wavelengths:
 1300 nm range standard: 1271, 1291, 1311, 1331, 1351, 1371, 1411 and 1431 nm
 1500 nm range optional: 1471, 1491, 1511, 1531, 1551, 1571, 1591 and 1611 nm
Output power, per channel, typical: -3 dBm (± 3 dBm)

Receiver CWDM

Input wavelengths:
 1300 nm range standard: 1271, 1291, 1311, 1331, 1351, 1371, 1411 and 1431 nm
 1500 nm range optional: 1471, 1491, 1511, 1531, 1551, 1571, 1591 and 1611 nm

Fiber Link Distance

3Gb/s..... up to 15.5 miles (25 km)
10Gb/s up to 6.2 miles (10 km)

Mechanical/Environmental

Dimensions (LxWxH) 8" \times 17.5" \times 1.75" (203.2 \times 444.5 \times 44.45 mm)
Weight, each end..... 5 lbs (2.27 kg)
Connectors: Optical ST
Input voltage..... 12 to 18 VDC
Power consumption <25 W
Indicators..... Power ON, Signal Presence, Optical Power
Temperature Range -4° to 131° F (-20° to 55 °C)
Humidity Range 0 to 95 % non-condensing

Compliance

Laser Safety..... Class 1 Laser
EMI/RFI..... Complies with IEC/EN 60825-1
Certifications RoHS



Grass Valley Technical Support

For technical assistance, please contact the Grass Valley Technical Support center nearest you:

Americas

Office hours: 9:00 a.m. – 9:00 p.m. (EST)
Telephone: 1-800-224-7882
Fax: +1 514 335 1614
E-mail: support@miranda.com

Asia

Office hours: 9:00 a.m. – 6:00 p.m. (GMT+8)
Telephone: +852 2539 6987
Fax: +852 2539 0804
E-mail: asiotech@miranda.com

Europe, Middle East, Africa, UK

Office hours: 9:00 a.m. – 6:00 p.m. (GMT)
Telephone: +44 118 952 3444
Fax: +44 118 952 3401
E-mail: eurotech@miranda.com

China

Office hours: 9:00 a.m. – 6:00 p.m. (GMT+8)
Telephone: +86 10 5873 1814
E-mail: asiotech@miranda.com

France

Office hours: 9:00 a.m. – 5:00 p.m. (GMT+1)
Telephone: +33 1 55 86 87 88
Fax: +33 1 55 86 00 29
E-mail: eurotech@miranda.com

Malaysia

Telephone: +60 3 2247 1808

EMERGENCY After Hours (Global)

Toll Free: 1-800-224-7882 (US and Canada)
Telephone: +1 514 333 1772

Corporate Head Office

Grass Valley
3499 Douglas-B.-Floreni
St-Laurent, Quebec H4S 2C6
Canada
Telephone: +1 514 333 1772
Fax: +1 514 333 9828
Web: www.miranda.com