

# MCS Panel Configuration Editor

Configuration Tool for iMC Master Control Panels

## User's Guide

UG0066-01

7 Nov 2012



A **BELDEN** BRAND

---

## Copyright © 2012 by Miranda Technologies

All rights reserved. No part of this manual may be reproduced in any form by photocopy, microfilm, xerography or any other means, or incorporated into any information retrieval system, electronic or mechanical, without the written permission of Miranda Technologies, Inc..

- Document Revision: 1.1
- Document Part Number: UG0066-01
- Software Version: 7.2.9.0

### Change History

| Rev. | Date      | ECO   | Description  | Approved |
|------|-----------|-------|--|----------|
| 1.0  | 29 Nov 11 | 17941 | Conforms to software release 7.2.0. This document started as a copy of UG0008. | D.Cox    |
| 1.1  | 07 Nov 12 | 18617 | Conforms to software release 7.2.9. New features. Bugs fixed.                  | D.Cox    |

### Notice

Due to continued product development, the accuracy of the information in this document may change without notice. The information and intellectual property contained herein is confidential between Miranda and the client and remains the exclusive property of Miranda. If you find any problems in the documentation, please report them to us in writing. Miranda does not warrant that this document is error-free.

### **FC** FCC Statement

This equipment has been tested and found to comply with the limits for a Class A digital device, pursuant to part 15 of the FCC Rules. These limits are designed to provide reasonable protection against harmful interference when the equipment is operated in a commercial environment. This equipment generates, uses, and can radiate radio frequency energy and, if not installed and used in accordance with the instruction manual, may cause harmful interference to radio communications. Operation of this equipment in a residential area is likely to cause harmful interference in which case the user will be required to correct the interference at his own expense.

### **CE** Declaration of Conformance (CE)

All of the equipment described in this manual has been designed to conform with the required safety and emissions standards of the European Community. Products tested and verified to meet these standards are marked as required by law with the CE mark.

When shipped into member countries of the European Community, this equipment is accompanied by authentic copies of original Declarations of Conformance on file in Miranda USA offices in Grass Valley, California USA.

## Trademarks

Miranda is a registered trademark of Miranda Technologies, Inc.

Brand and product names mentioned in this manual may be trademarks, registered trademarks or copyrights of their respective holders. All brand and product names mentioned in this manual serve as comments or examples and are not to be understood as advertising for the products or their manufactures.

## Software License Agreement and Warranty Information

Contact Miranda for details on the software license agreement and product warranty.

## Important Safeguards and Notices

This section provides important safety guidelines for operators and service personnel. Specific warnings and cautions appear throughout the manual where they apply. Please read and follow this important information, especially those instructions related to the risk of electric shock or injury to persons.

---

### WARNING

Any instructions in this manual that require opening the equipment cover or enclosure are for use by qualified service personnel only. To reduce the risk of electric shock, do not perform any service other than that contained in the operating instructions unless you are qualified to do so.

---

## Restriction on Hazardous Substances (RoHs)

Miranda is in compliance with EU Directive RoHS 2002/95/EC governing the restricted use of certain hazardous substances and materials in products and in our manufacturing processes.

Miranda has a substantial program in place for RoHS compliance that includes significant investment in our manufacturing process, and a migration of Miranda product electronic components and structural materials to RoHS compliance.

It is our objective at Miranda GVD to maintain compliance with all relevant environmental and product regulatory requirements. Detailed information on specific products or on the RoHS program at Miranda is available from Miranda Customer Support at

1-800-719-1900 (toll-free) or  
1-530-265-1000 (outside the U.S.).

---

## Symbols and Their Meanings



The lightning flash with arrowhead symbol within an equilateral triangle alerts the user to the presence of dangerous voltages within the product's enclosure that may be of sufficient magnitude to constitute a risk of electric shock to persons.



The exclamation point within an equilateral triangle alerts the user to the presence of important operating and maintenance/service instructions.



The ground symbol represents a protective grounding terminal. Such a terminal must be connected to earth ground prior to making any other connections to the equipment.



The fuse symbol indicates that the fuse referenced in the text must be replaced with one having the ratings indicated.



The presence of this symbol in or on Miranda equipment means that it has been designed, tested and certified as complying with applicable Underwriter's Laboratory (USA) regulations and recommendations.



The presence of this symbol in or on Miranda equipment means that it has been designed, tested and certified as essentially complying with all applicable European Union (CE) regulations and recommendations.

## General Warnings

A warning indicates a possible hazard to personnel which may cause injury or death. Observe the following general warnings when using or working on this equipment:

- Heed all warnings on the unit and in the operating instructions.
- Do not use this equipment in or near water.
- This equipment is grounded through the grounding conductor of the power cord. To avoid electrical shock, plug the power cord into a properly wired receptacle before connecting the equipment inputs or outputs.
- Route power cords and other cables so they are not likely to be damaged.
- Disconnect power before cleaning the equipment. Do not use liquid or aerosol cleaners; use only a damp cloth.
- Dangerous voltages may exist at several points in this equipment. To avoid injury, do not touch exposed connections and components while power is on.
- Do not wear rings or wristwatches when troubleshooting high current circuits such as the power supplies.
- To avoid fire hazard, use only the specified fuse(s) with the correct type number, voltage and current ratings as referenced in the appropriate locations in the service instructions or on the equipment. Always refer fuse replacements to qualified service personnel.
- To avoid explosion, do not operate this equipment in an explosive atmosphere.
- Have qualified service personnel perform safety checks after any service.

## General Cautions

A caution indicates a possible hazard to equipment that could result in equipment damage. Observe the following cautions when operating or working on this equipment:

- When installing this equipment, do not attach the power cord to building surfaces.
- To prevent damage to equipment when replacing fuses, locate and correct the problem that caused the fuse to blow before re-applying power.
- Use only the specified replacement parts.
- Follow static precautions at all times when handling this equipment.
- This product should only be powered as described in the manual. To prevent equipment damage, select the proper line voltage on the power supply(ies) as described in the installation documentation.
- To prevent damage to the equipment, read the instructions in the equipment manual for proper input voltage range selection.
- Some products include a backup battery. There is a risk of explosion if the battery is replaced by a battery of an incorrect type. Dispose of batteries according to instructions.
- Products that have (1) no on/off switch and (2) use an external power supply must be installed in proximity to a main power output that is easily accessible.



# toc

## Table of Contents

|          |  |          |
|----------|--|----------|
| <b>1</b> | <b>Preface .....</b>                           | <b>1</b> |
|          | Chapter Structure .....                        | 1        |
|          | The PDF Document .....                         | 2        |
|          | Terms, Conventions and Abbreviations .....     | 2        |
|          | Prerequisites .....                            | 3        |
|          | Options .....                                  | 4        |
|          | How to Use This Manual .....                   | 4        |
| <br>     |  |          |
| <b>2</b> | <b>Introduction .....</b>                      | <b>7</b> |
|          | About the Editor .....                         | 7        |
|          | Master Control System Overview .....           | 7        |
|          | NV9000 Router Control System .....             | 8        |
|          | Control Panels .....                           | 9        |
|          | Transition Processors .....                    | 10       |
|          | MCPMs .....                                    | 10       |
|          | Imagestore 750 .....                           | 10       |
|          | Other Miranda Products .....                   | 11       |
|          | Tally Processor .....                          | 11       |
|          | DC21 .....                                     | 11       |
|          | EBCP .....                                     | 11       |
|          | Intuition XG .....                             | 11       |
|          | MCPM Overview .....                            | 12       |
|          | Video Effects and Audio Overs .....            | 13       |
|          | Intuition XG .....                             | 13       |
|          | Transition Types .....                         | 13       |
|          | MCPM Types .....                               | 14       |
|          | MCE Summary .....                              | 15       |
|          | Machine Control .....                          | 16       |
|          | Intuition XG .....                             | 16       |
|          | Imagestore 750 Summary .....                   | 17       |
|          | Conceptual Model .....                         | 18       |
|          | Use in the iMC Master Control System .....     | 18       |
|          | NV9000's IP Address .....                      | 19       |
|          | PGM and PST Destination .....                  | 19       |
|          | Aux Destination .....                          | 19       |
|          | Fill and Key .....                             | 20       |
|          | Source Groups .....                            | 20       |
|          | Monitor Wall .....                             | 20       |
|          | Traditional vs. PresStation Preset Tally ..... | 20       |
|          | Configuration Editor Overview .....            | 21       |

---

|  |           |
|--|-----------|
| <b>3 Control Panels.....</b>                   | <b>23</b> |
| Panel Comparison .....                         | 24        |
| iMC-Panel-200 Summary .....                    | 25        |
| iMC-Panel-200 Buttons .....                    | 28        |
| iMC-Panel-200 Knobs.....                       | 29        |
| iMC-Panel-200 Touchscreen .....                | 29        |
| MCE and MCPM .....                             | 29        |
| Imagestore 750.....                            | 30        |
| iMC-Panel-200 Connectors .....                 | 30        |
| Power .....                                    | 30        |
| Ethernet .....                                 | 30        |
| GPI/Alarm .....                                | 31        |
| Audio Metering Input .....                     | 31        |
| iMC-Panel-300 Summary .....                    | 31        |
| iMC-Panel-300 Buttons .....                    | 33        |
| iMC-Panel-300 Knobs.....                       | 33        |
| iMC-Panel-300 Touchscreen .....                | 33        |
| MCE and MCPM .....                             | 33        |
| Imagestore 750.....                            | 34        |
| Functional Sections of the iMC-Panel-300 ..... | 34        |
| iMC-Panel-300 Connectors .....                 | 37        |
| Power .....                                    | 37        |
| Ethernet .....                                 | 38        |
| GPI/Alarm .....                                | 38        |
| Audio Metering Input .....                     | 38        |
| iMC-Panel-100 Summary .....                    | 39        |
| iMC-Panel-100 Buttons .....                    | 42        |
| iMC-Panel-100 Knobs.....                       | 43        |
| iMC-Panel-100 Monitor.....                     | 43        |
| MCE and MCPM .....                             | 43        |
| Imagestore 750.....                            | 44        |
| For Either .....                               | 44        |
| iMC-Panel-100 Connectors .....                 | 44        |
| USB Ports .....                                | 44        |
| VGA Port .....                                 | 44        |
| Power .....                                    | 45        |
| Ethernet .....                                 | 45        |
| GPI/Alarm .....                                | 45        |
| iMC-Panel-GUI Summary .....                    | 45        |
| GUI Buttons .....                              | 47        |
| Knobs and Slider .....                         | 48        |
| Functional Sections of the GUI .....           | 48        |
| Other Features .....                           | 50        |
| CECP Summary .....                             | 50        |
| CECP Buttons .....                             | 53        |
| CECP Knobs.....                                | 54        |
| CECP Touchscreen .....                         | 54        |
| CECP Connectors.....                           | 54        |
| Power .....                                    | 55        |
| Ethernet .....                                 | 55        |
| GPI/Alarm .....                                | 55        |
| Audio Metering Input .....                     | 55        |



---

|                                       |    |
|---------------------------------------|----|
| FECP Summary.....                     | 56 |
| FECP Buttons .....                    | 57 |
| FECP Knobs .....                      | 58 |
| FECP Touchscreen.....                 | 58 |
| Functional Sections of the FECP.....  | 58 |
| FECP Connectors .....                 | 60 |
| Power .....                           | 60 |
| Ethernet .....                        | 60 |
| GPI/Alarm .....                       | 60 |
| Audio Metering Input .....            | 61 |
| CECP GUI Summary .....                | 61 |
| GUI Buttons .....                     | 62 |
| Knobs and Slider .....                | 63 |
| Functional Sections of the GUI .....  | 63 |
| Other Features .....                  | 64 |
| CFCP Summary .....                    | 64 |
| CFCP Buttons .....                    | 66 |
| CFCP Knobs .....                      | 66 |
| Functional Sections of the CFCP ..... | 66 |
| CFCP Connectors.....                  | 68 |
| Power .....                           | 68 |
| Ethernet .....                        | 68 |
| GPI/Alarm .....                       | 68 |
| CP Aux Connector .....                | 68 |
| Ground Lug .....                      | 68 |
| FFCP Summary.....                     | 69 |
| FFCP Buttons .....                    | 70 |
| FFCP Knobs .....                      | 70 |
| Functional Sections of the FFCP.....  | 70 |
| FFCP Connectors .....                 | 71 |
| Power.....                            | 71 |
| Ethernet .....                        | 71 |
| GPI/Alarm .....                       | 72 |
| 'CP Aux' Connector.....               | 72 |
| Ground Lug .....                      | 72 |
| PC GUI Summary.....                   | 72 |
| GUI Buttons .....                     | 73 |
| Absence of Knobs .....                | 74 |
| Functional Sections of the GUI.....   | 74 |
| Aux/Preview GUI Summary.....          | 75 |
| GUI Buttons .....                     | 76 |
| Knobs and Slider .....                | 77 |
| Functional Sections of the GUI.....   | 77 |
| SCP Summary.....                      | 78 |
| SCP Buttons .....                     | 80 |
| SCP Knobs .....                       | 80 |
| Connectors .....                      | 81 |
| Misc. Topics.....                     | 81 |
| Channel Selection.....                | 81 |
| IP Addresses .....                    | 81 |
| Flip-Flop Mode.....                   | 82 |
| Modifiable Buttons.....               | 82 |

**4 Editor Basics ..... 83**

Editor Overview ..... 83

GUIs— Special Treatment ..... 86

    Configuration Files ..... 86

        Hardware Control Panels ..... 86

        GUIs ..... 87

Menus ..... 87

    File Menu ..... 88

        New ..... 88

        Open ..... 89

        Save ..... 89

        Save As ..... 89

        Write Config to Panel ..... 89

        Read Config from Panel ..... 91

        Exit ..... 91

    Tools Menu ..... 92

        Search for Devices ..... 92

        Get Panel Software Versions ..... 94

        Read Log from Panel ..... 95

        Update Panel Software ..... 95

    Help Menu ..... 97

        About MCS Panel Configuration Editor ..... 97

        Obtaining Technical Help ..... 98

Guidelines ..... 98

    IP Addresses ..... 98

        Renaming or Deleting ..... 99

        Changing an IP Address ..... 100

        Configuration Files ..... 100

    Operational Overview ..... 101

        New Configuration ..... 101

        Modifying an Active Configuration ..... 101

        Modifying a Stored Configuration ..... 102

        Updating a Panel ..... 102

**5 Operation (for MCEs and MCPMs) ..... 103**

New Configurations ..... 103

General ..... 105

Channel Selection List ..... 106

    Automatic Gang Mode ..... 107

    Kaleido X Integration ..... 107

    Channel Thumbnails ..... 108

    Usage ..... 108

User Button Layout ..... 109

Bottom Row Layout ..... 110

Logging Settings ..... 111

NV9000 Settings ..... 112

Advanced ..... 113

    Enable Automatic Navigation to Menu ..... 117

    Kaleido-X Integration ..... 117

    Start in Flip-Flop Mode ..... 117

    Panel LCD Brightness ..... 118

    PGM Selected Source Color ..... 118

    PGM Unselected Source Color ..... 118

    PST Selected Source Color ..... 118

|                                     |     |
|-------------------------------------|-----|
| PST Unselected Source Color .....   | 118 |
| 'Automation Off' Button Color ..... | 119 |
| Hide Mouse Cursor .....             | 119 |
| Enable Global Source Groups .....   | 119 |
| Enable 'Always Show Source' .....   | 119 |
| Menu Password .....                 | 120 |
| Button Assignments .....            | 120 |
| Main Source Button Qty .....        | 121 |
| The Button Table .....              | 121 |
| User Menu Lists .....               | 122 |
| Menu Layouts .....                  | 124 |
| Aux Delegates .....                 | 125 |
| Audio Monitoring Layout .....       | 127 |
| Audio Macros .....                  | 129 |

## 6 Button Functions (for MCEs and MCPMs) ..... 131

|                                  |     |
|----------------------------------|-----|
| Summary .....                    | 131 |
| SCP .....                        | 133 |
| Newer Panels .....               | 133 |
| FECP and iMC-Panel-300 .....     | 134 |
| Audio Macros .....               | 134 |
| Definable Button Functions ..... | 134 |
| Not Assigned .....               | 134 |
| Channel .....                    | 135 |
| Channel Select .....             | 135 |
| No Channels .....                | 135 |
| Gang Channels .....              | 136 |
| Channel Status .....             | 136 |
| Channel Control .....            | 136 |
| Salvo .....                      | 137 |
| GPI .....                        | 137 |
| GPI Output .....                 | 138 |
| GPI Input .....                  | 138 |
| GPI Input and Output .....       | 139 |
| System Control .....             | 140 |
| Panel Lock .....                 | 140 |
| Automation Off .....             | 140 |
| Transition Hold .....            | 141 |
| Fade to Black .....              | 141 |
| Audio Lock .....                 | 141 |
| System Status .....              | 142 |
| Kaleido-X Layout .....           | 143 |
| Group Select .....               | 143 |
| Flip-Flop .....                  | 144 |
| Bank Select .....                | 144 |
| Emergency Bypass .....           | 144 |
| Emergency Bypass Status .....    | 145 |
| Emergency Bypass Control .....   | 145 |
| Transition Type .....            | 145 |
| Transition Rate .....            | 146 |
| Breakaway .....                  | 146 |
| 'Dim' Buttons .....              | 146 |
| Dolby E Backup Audio .....       | 147 |
| Dolby E Status .....             | 147 |
| Dolby E Control .....            | 147 |

---

|  |            |
|--|------------|
| Audio Macros .....                             | 148        |
| Live Levels .....                              | 148        |
| Audio .....                                    | 149        |
| Monitors A and B .....                         | 149        |
| Meters .....                                   | 149        |
| Audio Level and Ratio .....                    | 150        |
| Video Effects .....                            | 150        |
| Dynamic Source Buttons .....                   | 151        |
| Menu Buttons .....                             | 152        |
| Menu Selection Buttons .....                   | 152        |
| Menu Navigation Buttons for the SCP .....      | 153        |
| Machine Control .....                          | 153        |
| XG Keyer Control .....                         | 154        |
| Aux Delegates .....                            | 155        |
| <br>   |            |
| <b>7 Operation (for Imagestore 750s) .....</b> | <b>157</b> |
| New Configurations .....                       | 158        |
| General .....                                  | 159        |
| Channel Selection List .....                   | 160        |
| Automation Focussing .....                     | 160        |
| Kaleido X Integration .....                    | 161        |
| Channel Thumbnails .....                       | 162        |
| Usage .....                                    | 162        |
| User Button Layout .....                       | 163        |
| Bottom Row Layout .....                        | 164        |
| Logging Settings .....                         | 165        |
| Advanced .....                                 | 166        |
| Kaleido-X Integration .....                    | 167        |
| Source Groups .....                            | 168        |
| Panel LCD Brightness .....                     | 168        |
| Automation .....                               | 168        |
| Enable Automation Focussing .....              | 168        |
| Enable iTX Integration .....                   | 168        |
| Initially Arm as Fade .....                    | 169        |
| Always Show Source .....                       | 169        |
| Channel Acquisition .....                      | 169        |
| Enable Traditional PST Tally .....             | 170        |
| PGM Selected Source Color .....                | 170        |
| PGM Unselected Source Color .....              | 170        |
| PST Selected Source Color .....                | 170        |
| PGM Unselected Source Color .....              | 170        |
| 'Automation Off' Button Color .....            | 171        |
| NV9000 Settings .....                          | 171        |
| Button Assignments .....                       | 172        |
| Main Source Button Qty .....                   | 173        |
| The Button Table .....                         | 173        |
| Audio Monitoring Layout .....                  | 174        |
| Aux Row .....                                  | 175        |
| Preview/User Row .....                         | 176        |
| Monitor Wall .....                             | 177        |
| Destinations for Imagestore 750 Sources .....  | 177        |
| Destinations for Imagestore 750 Outputs .....  | 178        |
| Destinations for Imagestore 750 Sources .....  | 178        |
| About Router Connections .....                 | 178        |
| Aux Connections .....                          | 179        |

**8 Button Functions (for Imagestore 750s) ..... 181**

Summary ..... 181  
Definable Button Functions ..... 182  
    Channel Functions ..... 182  
        Channel ..... 182  
        No Channels ..... 183  
        Salvo ..... 183  
        Gang Channels ..... 184  
    GPI ..... 184  
        GPI Output ..... 184  
        GPI Input ..... 185  
        GPI Input and Output ..... 185  
    Utility Functions ..... 186  
        Panel Lock ..... 186  
        Auto Off ..... 186  
        Group Select ..... 186  
        Menu ..... 187  
        Macro Arm ..... 188  
        Fire Macro ..... 188  
        Fade to Black ..... 188  
        Fade to Silence ..... 189  
        PGM DVE Enable ..... 189  
        PST DVE Enable ..... 189  
        Kaleido-X Layout ..... 190  
    Take Functions ..... 190  
        Take Primary ..... 190  
        Take Secondary ..... 191  
    Audio Functions ..... 191  
        Audio Lock ..... 191  
    Transition Type Functions ..... 191  
    Transition Rate Functions ..... 192  
    Automation Assist ..... 192

**Appendix A: References ..... 193**

GPIs ..... 193  
    Panel GPI ..... 193  
    MCPM GPI Inputs ..... 193  
    MCPM GPI Outputs ..... 194  
    Imagestore 750 GPI Inputs and Outputs ..... 194  
    Imagestore 750 AES Connector ..... 196

**Glossary ..... 197**

**Index ..... 199**

**Contact Us ..... 211**

## Table of Contents

---

# 1

## Preface

Chapter 1 is an introduction to the MCS Panel Configuration Editor User's Guide.

### Topics

|  |   |
|--|---|
| <a href="#">Chapter Structure</a> .....                    | 1 |
| <a href="#">The PDF Document</a> .....                     | 2 |
| <a href="#">Terms, Conventions and Abbreviations</a> ..... | 2 |
| <a href="#">Prerequisites</a> .....                        | 3 |
| <a href="#">Options</a> .....                              | 4 |
| <a href="#">How to Use This Manual</a> .....               | 4 |

## Chapter Structure

This user's guide provides operating instructions for the MCS Panel Configuration Editor—software that configures control panels in a master control system.

This guide includes the following chapters:

- Chapter 1, [Preface](#), outlines effective ways to use this guide, provides a list of terms and conventions, and prerequisites for using the editor to configure a panel.
- Chapter 2, [Introduction](#), presents an overview of the master control system, review of panel features, and a summary of the configuration editor.
- Chapter 3, [Control Panels](#), briefly describes the control panels.
- Chapter 4, [Editor Basics](#), provides orientation, editing, and basic operating instructions.
- Chapter 5, [Operation \(for MCEs and MCPMs\)](#), provides more detailed operating instructions for panels that support MCEs and MCPMs.
- Chapter 6, [Button Functions \(for MCEs and MCPMs\)](#), describes how to assign functions to configurable buttons for use with MCEs and MCPMs.
- Chapter 7, [Operation \(for Imagestore 750s\)](#), provides more detailed operating instructions for panels that support the Imagestore 750.
- Chapter 8, [Button Functions \(for Imagestore 750s\)](#), describes how to assign functions to configurable buttons for use with the Imagestore 750.
- Appendix A, [References](#), provides useful reference sections.

An [Index](#) and [Glossary](#) are also provided for your reference.

## The PDF Document

This guide is provided in PDF format, allowing you to use Acrobat's "bookmarks" to navigate to any desired location. You can also easily print a hardcopy. Please note:

- Use the Table of Contents or the bookmarks page to jump to any desired section.
- Many hyperlinks are provided within the chapters.
- Use the Index to jump to specific topics within a chapter. Each entry in the index is a hyperlink.
- Use Acrobat's 'Go to Previous View' and 'Go to Next View' buttons to retrace your complete navigational path.
- Use the 'First Page', 'Previous Page', and 'Next Page', and 'Last Page' buttons to go to the first, previous, next, or last page within a PDF file.

---

### Note

To display the navigation buttons, right-click the Tool Bar area, and check 'Navigation'.

---

- Use Acrobat's extensive search capabilities, such as the 'Find' tool and 'Search' tool to perform comprehensive searches as required.

## Terms, Conventions and Abbreviations

The following conventions are used throughout this guide:

- The symbol ▲ denotes an example or a special message.
- Entries enclosed in single quotation marks or written in ***bold-face*** or Capital Letters denote menus and buttons, and on occasion, physical control panel buttons and knobs.

Click 'Apply' to . . .

The following terms and abbreviations are used throughout this guide:

- The terms "panel" and "control panel" refer to any master control panel. These include:

|                 |   |
|-----------------|---|
| FFCP            | full-function control panel.                        |
| CFCP            | compact full-function control panel.                |
| SCP             | simple control panel.                               |
| CECP GUI        | software control panel ( <i>modified</i> ).         |
| Aux/Preview GUI | software control panel (a variant of the CECP GUI). |
| PC GUI          | software control panel (old).                       |
| CECP            | compact enhanced control panel.                     |
| CECP M1         | compact enhanced control panel (modified).          |
| FECF            | full-size enhanced control panel.                   |
| iMC-Panel-300   | full-size control panel, based on the FECF.         |
| iMC-Panel-200   | compact control panel, based on the CECP.           |
| iMC-Panel-100   | rack-mount control panel, based on the SCP.         |
| iMC-Panel-GUI   | software control panel, based on the CECP GUI.      |
- "MCPM" stands for Master Control Processing Module—a "transition processor" that installs in the master control frame. One MCPM provides one master control channel.



- “MCE” stands for Master Control Engine. An MCE as a type of MCPM and provides one master control channel.
- MasterConfig is the software that configures MCPMs.
- MasterDiag is the software used to assign MCPMs network addresses and perform diagnostics.
- MasterLogo is the software that converts your graphic images into logos in the format required by an MCPM. It also uploads logos to MCPMs.
- The MCS Panel Configuration Editor is the software that configures control panels.
- “The editor” and “the configuration editor” are abbreviations for the name of this software.

Other terms, used occasionally, include the following:

- The Imagestore 750 is a transition processor. It is also called “channel branding processor.” An Imagestore 750 is a 1RU device that provides a single channel of master control (as do MCEs and MCPMs).
- Intuition XG is a single- or dual-channel graphics processor. The term “Intuition XG” can encompass all the hardware and software involved in the Intuition XG component of master control.
- XMedia is a term that includes different software applications that create and manage images, keyers, logos, etc. used by Intuition XG.
- Xplay and the XG Dashboard are software applications under XMedia. Both of these are used to configure the Intuition XG processor.
- Xbuilder and Xstudio are creative software applications under XMedia.
- Oxtel is a division of Miranda. Its name is used to identify certain ports of the Intuition XG hardware. The Oxtel protocol is used by the Imagestore 750 in the master control system.
- The term “DC21” identifies the master control device controller used for machine control. “DC21” is trademark of DNF Controls.

## Prerequisites

Please observe the following important prerequisites:

- At least one transition processor.

You will need:

- (1) Optionally, an NV5100MC MC frame with control cards, I/O cards, and one or more MCEs or MCPMs, properly installed.
  - (2) Optionally, one or more Imagestore 750s, properly installed.
- At least one PC (for configuration) is required.  
Configuration software is to be installed on this PC. The software is available on the master control software and documentation CD (SB0243).
  - At least one master control panel properly configured.  
For operation, the configuration PC, MCPMs, and master control panels must be connected on an Ethernet LAN.

- NV9000 requirements met.

If you are using a master control system in conjunction with an NV9000 router control system, ensure that the NV9000 is properly installed and that your NV5100MC frames and the NV9000 are communicating with each other.

A connection to the NV9000 is recommended during the configuration of router pre-select functions and salvo functions, although it not strictly necessary.

- User accounts for PCs used for master control set to 'Standard User' or better.

Master control software does not function properly when user accounts are set to 'Restricted User' or its equivalent.

Audio monitors and meters, video monitors, video sources, audio sources, and other peripherals are **not** required to test the basic operation of a master control system (and are therefore not required to test the editor).

The editor allows you to create panel configurations off-line. A connection to a panel is required only to upload the configuration to the panel. As already mentioned, however, connection to the NV9000 is recommended during the configuration of router pre-select functions.

## Options

The Master Control Tally Processor is an option. It provides 32 GPI inputs and 32 GPI outputs. It can monitor master control events and trigger master control events.

The Master Control (DC21) Device Controller is an option but is required if your master control system is to perform machine control. It also has 32 GPI inputs and 32 GPI outputs and has 4 serial ports.

Intuition XG is an option that can be enabled for specific MCEs. Intuition XG adds rich branding to master control because it includes sophisticated design tools and a powerful graphics processors. If Intuition XG is enabled for MCEs, at least one SWB input card (and backplane module) is required.

The Imagestore 750 transition processor is an option. An Intuition XG processor can provide signals for the Imagestore 750.

## How to Use This Manual

If you have already read the *Master Control Reference Manual*, you can skip much of the introductory material.

Chapter 3, [Control Panels](#) is a short review of control panel features and recommended reading.

Please do read Chapter 4, [Editor Basics](#). Many characteristics of the menus, buttons, and configuration pages in the editor are obvious, but some are not.

The editor is not very complex and the configuration pages are simple. We recommend that you first skim through all the operations sections. Then read carefully only the sections you need to read, one at a time.

If you intend to use the Intuition XG component of master control, please obtain Intuition documentation from Miranda.

If you incorporate Imagestore 750s in your system, please obtain the *Imagestore 750 User Manual* from Miranda. (The *Master Control Reference Manual* has a brief description of the Imagestore 750 if you need a quick tutorial.)



# 2 Introduction

Chapter 2 is an introduction to the MCS Panel Configuration Editor.

## Topics

|  |    |
|--|----|
| <a href="#">About the Editor</a> .....               | 7  |
| <a href="#">Master Control System Overview</a> ..... | 7  |
| <a href="#">MCPM Overview</a> .....                  | 12 |
| <a href="#">MCE Summary</a> .....                    | 15 |
| <a href="#">Imagestore 750 Summary</a> .....         | 17 |
| <a href="#">Configuration Editor Overview</a> .....  | 21 |

## About the Editor

The MCS Panel Configuration Editor configures these master control panels:

|               |               |                 |               |
|---------------|---------------|-----------------|---------------|
| iMC-Panel-200 | iMC-Panel-300 | iMC-Panel-GUI   | iMC-Panel-100 |
| CECP          | FECP          | CECP GUI        | SCP           |
| CFCP          | FFCP          | PC GUI          |               |
| CECP M1       |               | Aux/Preview GUI |               |

Chapter 3, [Control Panels](#), is a review of the panels that this configuration editor can configure.

▲ Panels other than the four iMC panels can be regarded as legacy panels.

The editor configures *any* panel to control MCEs and MCPMs. The editor configures certain panels also to control Imagestore 750s. The panels that can control Imagestore 750s are the iMC-Panel-100, iMC-Panel-200, iMC-Panel-300, and the iMC-Panel-GUI.

The Imagestore 750 requires controls that are quite different from the controls used for MCEs and MCPMs. Chapters 5 and 6 describe configuration for MCEs and MCPMs. Chapters 7 and 8 describe configuration for the Imagestore 750.

## Master Control System Overview

Miranda's master control system — a multi-channel switcher — might include one or more MCEs or MCPMs in NV5100MC frames and one or more Imagestore 750s. The frames are 8RU assemblies that have 16 I/O card slots that can operate in conjunction with other switchers, routers, an NV9000 router control system, and other products.

Each frame holds one or more MCEs or MCPMs and optionally a multi-format router. The MCEs and MCPMs are modules that actually perform the master control switching. Each MCE or MCPM is considered a *channel*.

The Imagestore is an independent 1RU transition processor. Like the MCE and MCPM, it is also considered a *channel*.

Transition processors (MCPMs, MCEs, and Imagestore 750s) and control panels communicate on an Ethernet LAN. When an operator presses control panel buttons (the 'Transition' button, for example), the control panel issues commands to a transition processor. The transition processor responds with status and (unless a problem exists) executes the command. When a command is successfully executed, the transition processor notifies the panel, which updates its displays and indicators accordingly.

Figure 2-1 shows the basic relationships in a master control system:

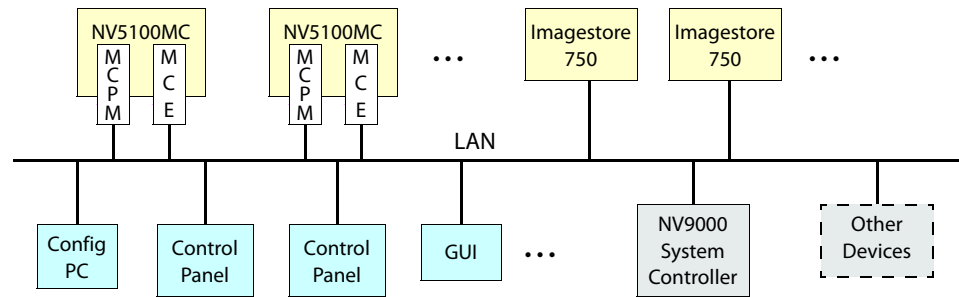

Fig. 2-1: Master Control Network

Master control can work in conjunction with the NV9000 router control system. In such a configuration, an MCE or MCPM (a channel) has access to the *entire* router input space, with the ability to assign any router source dynamically to control panel buttons.

Most control panels can control one or more channels at any time — but usually one at a time. Operators can select which channel(s) to control. When you change channels, control panel updates take about a second. We say that the panel *attaches* the newly selected channel, and the channel's own source layout, transition rates, and layer presets are available for use.

Each channel can also be operated under automation. An MCE, MCPM, or Imagestore 750 can be controlled by multiple control panels.

A panel can gang-control multiple MCEs and MCPMs or multiple Imagestore 750s.

Automation for MCEs and MCPMs uses *NVISION Serial Protocol for Master Control*; the Imagestore 750 uses Oxtel automation.

Master control operators can switch between control of MCEs, MCPMs, and Imagestore 750s without difficulty. The panel will adjust itself, particularly its display, according to the type of transition processor under control.

## NV9000 Router Control System

A master control system can be viewed as a part of an NV9000 system. Alternatively, the NV9000 can be regarded as a provider of inputs to the master control system.

In either case, master control allows router outputs as master control inputs and allows an operator (or automation) to take any router source to the master control output.

An MC system used in conjunction with an NV9000 system must be connected to the NV9000 (in the control section of the master control frame).

For MCEs and MCPMs, the panel controls router sources from the NV9000 (through various means). For the Imagestore 750, the panel configuration controls router destinations (from the NV9000) for monitor walls.

## Control Panels

Presently there are 2 hardware control panels and 1 software control panel (GUI):

|               |   |
|---------------|---|
| iMC-Panel-GUI | A software control panel. This panel also runs on a PC and has a graphical user interface. This GUI is a software emulation of the <i>iMC-Panel-200</i> . This GUI is designed to operate with (or without) a touch-sensitive screen. |
| iMC-Panel-100 | A 3RU rack-mounted panel with a separate rack-mountable touchscreen display. This panel has reduced size (less than 4" in depth) and reduced cost.  |
| iMC-Panel-200 | A compact hardware control panel that has a large LCD touchscreen, many function buttons, and a joystick. The iMC-Panel-200 mounts on a desktop or work surface. All buttons have LCD legends and color-coding.                       |
| iMC-Panel-300 | A "full-size" control panel that has a large LCD touchscreen, many function buttons, and a joystick. The iMC-Panel-300 mounts on a desktop or work surface. All but 2 buttons have LCD legends and color-coding.                      |

There are 6 *legacy* hardware control panels and 3 *legacy* software control panels:

|                  |   |
|------------------|---|
| NV5128-MC-FFCP   | FFCP, or "full-function" control panel. A fairly large console having push-buttons that support various fixed and configurable functions, an LCD touchscreen, and several audio control knobs. The FFCP can be mounted in a recess in a desktop or work surface.          |
| NV5128-MC-CFCP   | CFCP, or compact "full-function" control panel. A console similar to the FFCP, but smaller, with fewer buttons and more flexibility. The CFCP can be mounted in a 19" rack. It can also be mounted in a recess in a desktop or work surface.                              |
| NV5128-MC-GUI    | (Old) software control panel, also called the PC GUI. This panel runs on a PC and has a graphical user interface, hence the name "GUI." This GUI is a software emulation of the <i>FFCP</i> . This GUI is designed to operate with (or without) a touch-sensitive screen. |
| NV5100MC-GUI     | (New) software control panel, also called the "CECP GUI." This panel also runs on a PC and has a graphical user interface. This GUI is a software emulation of the <i>CECP</i> . This GUI is designed to operate with (or without) a touch-sensitive screen.              |
| Aux/Preview GUI  | The Aux/Preview GUI is not a separate product, but a configuration option for the <i>original</i> CECP GUI. The Aux/Preview GUI option does <b>not</b> support the Imagestore 750.  |
| NV5100MC-CECP    | CECP, or compact enhanced control panel. The CECP mounts on a desktop or work surface. It has a larger touchscreen, and additional features such as a metering input, preview and aux button sets, and a joystick. All buttons have LCD legends and color-coding.         |
| NV5100MC-CECP-M1 | The CECP M1 is a variant of the <i>original</i> CECP: It has two metering inputs, A and B, but does not have a joystick or a preview button row. In all other matters, it is the same as the original CECP.   |

|               |  |
|---------------|--|
| NV5100MC-FECP | FECP, or “full-size” enhanced control panel. The FECP mounts on a desktop or work surface. All but 2 buttons have LCD legends and color-coding.  |
| NV5100MC-SCP  | SCP, or simple control panel. The SCP is a 3RU rack-mount unit. Although it has function buttons and audio control knobs, it has no touchscreen: the menu items are encoded in the button legends. |

None of these legacy panels supports the Imagestore 750. Some of the legacy panels do not support all the newer features of the MCEs.

## Transition Processors

Transition processors include MCEs, MCPMs, and Imagestore 750s.

MCEs are a specific type of MCPM, although they have advanced features that other MCPMs do not have.

### MCPMs

MCPMs (master control processing module) are the devices that perform master control switching and mixing. There are several types of MCPMs:

|                      |   |
|----------------------|---|
| MCPM-SD              | 2-slot modules that process standard definition (SD) video. Provides 3 keyers, 2 logos, 1 squeezeback layer, 4 AES outputs, and 8 analog audio outputs in addition to program output.   |
| MCPM-HD,<br>MCPM-HD2 | 4-slot modules that process either high definition (HD) video. Provides 3 keyers, 2 logos, 1 squeezeback layer, 4 AES outputs, and 8 analog audio outputs in addition to program output. Two slots can be filled with router output cards.  |
| MCPM-SDHD            | 4-slot modules that process either HD or SD video, as a field-programmable option. Provides 3 keyers, 2 logos, 1 enhanced squeezeback layer, 4 AES outputs, and 8 analog audio outputs in addition to program output. One of the slots can be occupied by a router output card.           |
| MCPM-MK-SD           | 1-slot modules that process standard definition (SD) video. Provides 3 keyers, 1 logo, but no squeezeback. These modules are also named “mixer/keyers” or “branding engines.”   |
| MCPM-MK-HD           | 2-slot modules that process high definition (HD only) video. Provides 3 keyers, 1 logo, and no squeezeback. Unlike other MCPMs, this model accepts inputs (16) from its backplane, <b>not</b> the frame’s motherboard. These modules are also named “mixer/keyers” or “branding engines.” |
| MCE                  | A 1- to 3-slot module that processes either HD or SD video, as a field-programmable option. MCEs are considered “next generation” processors and have new architecture. See <a href="#">MCE Summary</a> , on page 15.   |

### Imagestore 750

The Imagestore 750 (called a “channel branding processor”) is an independent 1RU transition processor. It supports either HD or SD video input. It supports A/B mixing for program and preview, and provides 4 “downstream keyers” and optionally 2 DVEs for both program and preview. Refer to XREF and the Master Control Reference Manual for details.



The iMC master control system includes the LGK-3901, DSK-3901, and ISM-3901. These are transition processors that fit in a 3RU Densité frames. The Master Control system treats these as if they were Imagestore 750s. These units are configured using the Imagestore 750 Configurator and each of the units has a browser application that is similar to the one provided by the Imagestore 750.

## Other Miranda Products

Listed here are products that relate to master control.

### Tally Processor

Miranda offers a third-party “tally processor”—a 1RU device that provides 32 optically isolated inputs and 32 relay outputs, also optically isolated. Through Miranda’s NVISION Ethernet protocol (NVEP), the tally processor can sense master control events such as main source selections and transitions and trigger master control events.

Multiple tally processors can be added to a master control network.

### DC21

The DC21 is a 1RU device (from DNF)—very much like the Tally Processor—that (1) performs GPIO functions and (2) has 4 serial ports in support of machine control.

Each of the serial ports can be configured for one of 3 protocols: Sony, Odetics, or VDCP.

The GPOs can be configured, in adjacent pairs, to control up to 16 devices with 100 ms start and stop pulses. The odd member of the pair carries the start pulse and the even member carries the stop pulse. GPOs not used for master control may be programmed to respond to GPI and device control events.

### EBCP

The emergency bypass control panel (EBCP) is a simple one: it is a 1RU panel that has two large button switches. One says “Main” and the other says “Bypass.” Pressing the red “Bypass” button places an MCPM or MCE in bypass mode. Pressing the green “Main” button enables normal mode. (The panel controls only the MCPM to which it is connected.)

### Intuition XG

Intuition XG is a combination of the following:

- Intuition XG—a single- or dual-channel HD/SD graphics processor.

This processor stores video “key layers” and transmits the keys (fill and key) on demand. Fully In its maximum configuration, the processor can store up to 1.8 TB of video (about 360 hours at 10 Mbps).

The Intuition XG can “play out” video upon a signal from an MCE. The MCE treats the video as a key source and mixes the video from the with program or preset output.

The keys can also include CG and real-time or “live” data feeds.

The Intuition XG processor receives information regarding what to play and when to play it from an MCE over its Ethernet connection.

- XMedia software for configuration and for composing, rendering, and previewing graphics. Xmedia includes these applications among others:

*XG Dashboard.* An application that allows you to modify the settings and behavior of the Intuition XG and its software.

*XPlay*—“media event sequencer” used to configure the Intuition XG and to manage clips. Xplay must be running on the Intuition XG processor for correct operation under master control.

*Xbuilder*—“template population” and “promo timeline control.”

*Xstudio*—“template creation.” Xstudio can create video segments that, while executing in the Intuition XG processor, control an MCE’s squeeze effects and audio overs.

There is an ‘Int XG’ button and a ‘Preview Int XG’ button on the main menu of the iMC-Panel-100, iMC-Panel-200, CECP, CECP M1, iMC-Panel-300, FECF, iMC-Panel-GUI, and CECP GUI. Each causes a menu of Intuition XG key layers to be displayed. These control panels might also have ‘XG layer’ buttons on the preset and program buttons and an ‘XG keyer control’ among the configurable buttons.

## MCPM Overview

An MCPM (master control processing module) is also called a *transition processor*. It performs the bulk of what occurs in master control. A master control system has one or more MCPMs. MCEs are advanced MCPMs and offer additional capabilities. See [MCE Summary](#), on page 15.

Control panels govern the actions performed by MCPMs (and MCEs).

The MCPM transitions its output from one program source to another and to maintain a smooth transition as it does so. Transitions involve video effects and audio “overs.” A program source is called a *main* source in contrast to other sources, such as those for video keyers.

What the MCPM produces as output is called *program* and what is next to be on the program output is called *preset*. An operator at a control panel or an automation system presets a *main* source (video and audio) and zero or more video effects or audio overs. During a transition, the MCPM mixes the preset and program video and the preset and program audio. The video effects and audio overs fade in or out as required by the transition rate and transition type. At the end of the transition, what was on preset is now on program. The MCPM also has options to swap the preset and program settings and to clear effects from preset after the transition.

The MCPM adheres to the “audio follows video” paradigm: a main source in the MCPM is considered a video input with attached audio inputs.

The MCPM provides 8 channels of audio processing. Each main source (on both program and preset) can have 8 channels of audio. Each audio channel can be individually configured. MCEs provide 16 channels of audio processing.

The MCPM can process Dolby-E encoded audio input if the MCPM has a Dolby module installed.

An MCPM can switch from normal program output to emergency program output during periods of “emergency” or malfunction. MCPMs have an *emergency bypass* control that performs the switch.

All MCPMs provide audio metering outputs and audio monitoring outputs. All MCPMs have auxiliary functions (such as GPIs). Panel operators can control the program and preset audio levels and control audio monitor output. Panel operators can control MCPM GPIs and panel GPIs.

## Video Effects and Audio Overs

Video effects include:

keyer 1, logo A, squeezeback, keyer 2, keyer 3, logo B.

The MCPM applies video effects, layered cumulatively, to the selected main source (preset or program) in the order listed above.

A *key*<sup>1</sup> is a video overlay. A key can have two video sources: key (or mask) and fill. Some keys have only one source—fill—and the mask is derived from the luminance of the fill. These keys are called “self-keys.” A *keyer* is a key processor and is selectable at the control panel or by automation.

- ▲ For MCEs only, an external Intuition XG processor can provide video fill and key sources for 1 or 2 of the keyers. See [Intuition XG](#) on page 13.

A *logo* is a graphic overlay.

*Squeezeback* means that program output is either scaled or cropped to a specified portion of the video image. There are two forms of squeezeback—basic and enhanced.

An *over* is an audio overlay. The MCPM mixes audio over and program audio at some ratio that can be preconfigured and also adjusted at the control panel.

Not all MCPMs support all effects. Some control panels can be configured with a reduced set of effects.

### Intuition XG

MCEs can be connected to Intuition XG subsystems. The Intuition XG stores video keys and plays them out when directed by a signal from the MCE.

- ▲ An Intuition XG processor has either one or two channels. Each channel provides up to 4 layers. The layers are selected or deselected with XG layer buttons.

It is MasterConfig that defines the connections between the MCE and Intuition XG hardware. The MCS Panel Configuration Editor configures the control panel buttons that operate the Intuition key layers.

The Intuition XG can provide real-time or “live” character generation.

### Transition Types

A transition can be fast, medium, slow, or controlled by a transition lever arm (TLA). The exact duration of “fast,” “medium,” and “slow” is configurable. A transition controlled by a TLA is also called a “manual” transition.

Basic transition types include cut, V-fade (or fade-fade), cut-fade, cross-fade (or X-fade), and fade-cut. “Preset black” transitions include cut/cut, V-fade, cut-fade, and fade-cut, but not cross-fade.

The MCPM can also perform “fade-to-black” or FTB. An FTB fades the program video to a pre-defined matte (and program audio to silence). The matte can be any color, not just black.

The master control system allows “hot cuts” although they are not recommended.

---

1. A *keyer* is the firmware that mixes key signals with upstream video.

## MCPM Types

There are 7 MCPM types:

|          |                            |           |
|----------|----------------------------|-----------|
| MCPM-SD  | MCPM-MK-SD ("Mixer/Keyer") | MCPM-SDHD |
| MCPM-HD  | MCPM-MK-HD ("Mixer/Keyer") | MCE       |
| MCPM-HD2 |                            |           |

All MCPMs have common characteristics, such as audio meter outputs, GPIO, clean-feed outputs, and emergency bypass capability, but also have many differences.

The mixer/keyers do not have squeezeback and have one logo inserter (logo B). The MCPM-SDHD provides enhanced squeezeback.

The mixer/keyers do not have analog audio outputs and do not support Dolby E.

The MCE (master control engine) has new architecture and differs from other MCPMs. See [MCE Summary](#), on page 15.

Figure 2-2 shows the MCPM-SDHD, one of the several MCPM types:

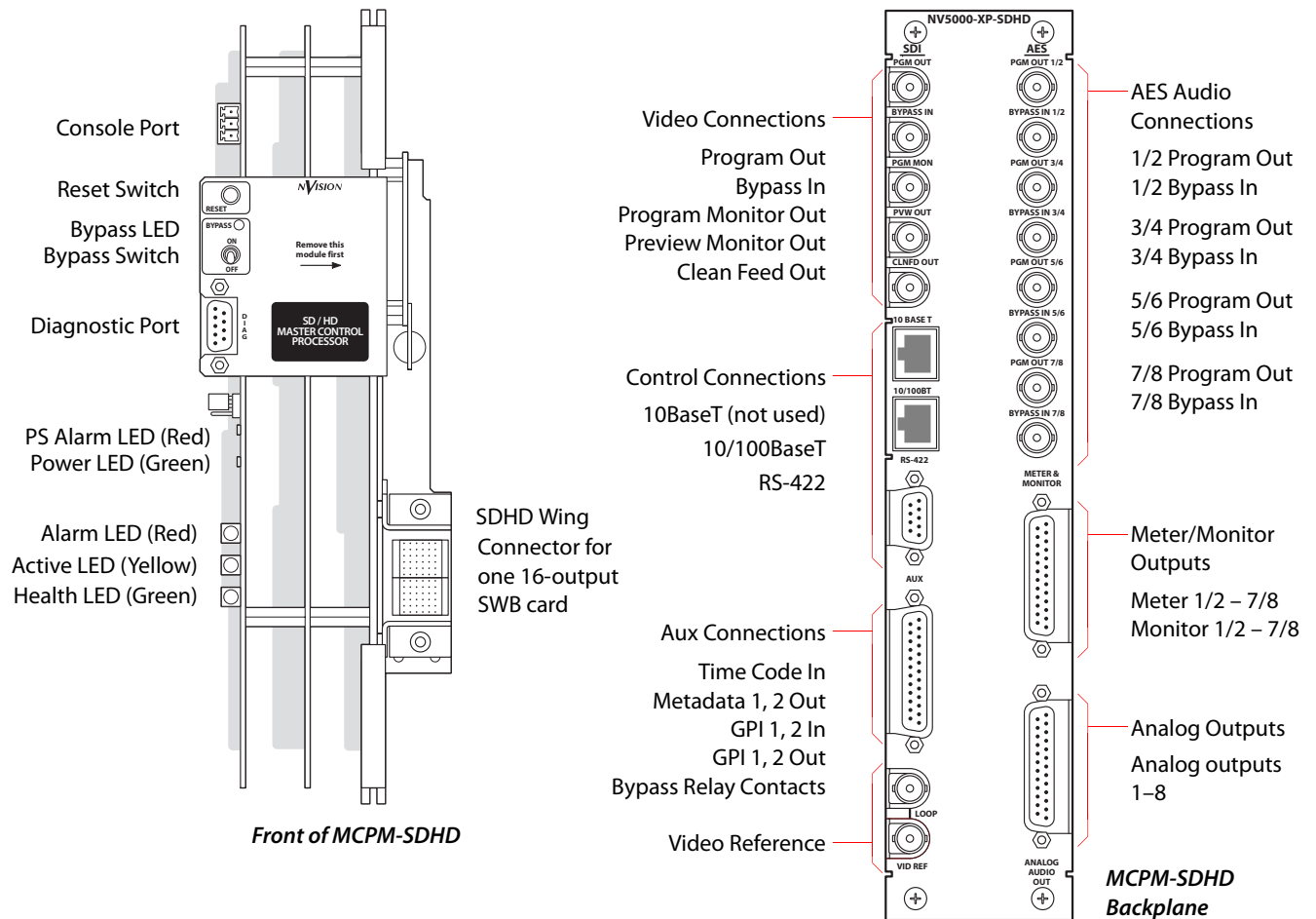

Fig. 2-2: MCPM-SDHD (Front, Backplane)

## MCE Summary

MCEs (master control engines) are the “next generation” of MCPMs — devices that perform master control switching and mixing.

▲ Not all features of the MCE product line are available yet.

The MCE is an extendable product, occupying up to 3 card slots, with a full set of features. There are 4 modules in the MCE card set:

- MCE-CORE. The minimum MCE comprises this single (full-size) card that performs *core* master control functions.
- MCE-PVW. The *preview* module supports a preview bus.
- MCE-AXM. The *audio expansion module* supports Dolby E and additional audio functions. The AXM provides Dolby E decoders for the program and preset buses and audio outputs at its backplane. The decoders are (optional) third-party daughter cards.
- MCE-DVE. The *digital video effect* cards are mezzanine (small) cards that can be added to the core and the preview cards for additional video effects and squeezeback.

MCEs have inputs and outputs similar to those for MCPMs, such as audio meter outputs, GPIO, clean-feed outputs, and emergency bypass capability. All MCEs have a reset switch, a bypass toggle (for the emergency bypass relay) and an diagnostic port at their front. The diagnostics port is a DE9, RS-232. The MCE can process either HD or SD signals as a field-programmable option.

Notable differences between the MCEs and older MCPMs include:

- The MCE has 16 audio channels.
- The MCE's audio output is embedded.
- MCE audio and video connectors are coaxial (1.0/2.3 DIN) connectors; MCPM audio and video connectors are BNCs.
- MCEs have 2 clean feed outputs and 2 aux outputs.
- The audio monitor outputs of MCEs are completely independent and have 16 audio channels each.
- MCEs that have AXM cards have more AES outputs and more Dolby metadata outputs than MCPMs have. Those outputs are configurable.
- All MCE logos are stored in non-volatile memory.
- MCEs can receive key inputs from Intuition XG processors.
- MCEs provide machine control and pre-roll functions.

There are other differences.

Figure 2-3 shows the front of one of 4 possible MCE assemblies and its associated backplanes:

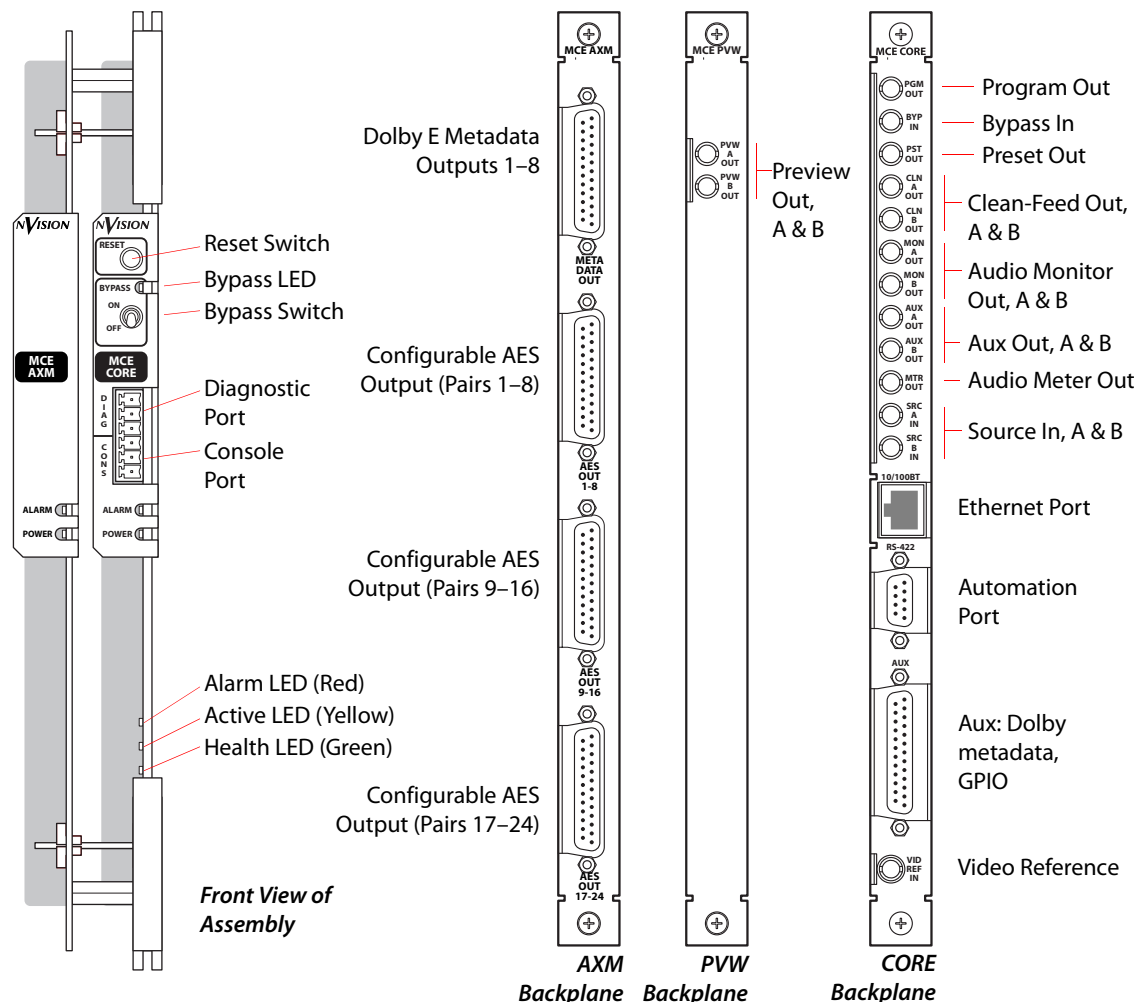

Fig. 2-3: MCE Assembly, Core, Preview, and AXM Backplane Modules

## Machine Control

MCEs have machine control functions and can initiate pre-roll in selected media.

It is in MasterConfig that machine control and pre-roll parameters are configured. It is in the MCS Panel Configuration Editor that buttons for machine control and pre-roll are defined.

Master control uses the DC21 device controller to carry out machine control operations. Please refer to the *DC21 Device Controller User's Guide* for information.

There are some methods and requirements for setting up machine control—in MasterConfig, in MCS Panel Configuration Editor, and in the DC21 itself.

## Intuition XG

MCEs can be configured to deliver video generated by an Intuition XG processor.

It is in MasterConfig that Intuition XG parameters are configured. It is in the MCS Panel Configuration Editor that buttons for Intuition XG control are defined.

## Imagestore 750 Summary

The Imagestore 750<sup>1</sup> is an independent transition processor (also called a “channel branding processor”) that can operate as a stand-alone unit with or without automation, or as part of Miranda’s iMC master control system. In the context of the combined master control system, it operates in conjunction with an NV9000 router control system that provides video and audio sources and one or more master control panels, such as the iMC-Panel-200, that provide commands. The Imagestore 750 issues switching instructions to the NV9000 when it receives commands from a master control panel.

This is a front view of the Imagestore 750:



The Imagestore 750 is essentially an A/B transition processor that inserts video effects (DVEs and DSKs) and voice-overs into its output. It has many configuration options. The software used is the “Imagestore 750 Configurator.”

This is a rear view showing the I/O, control, and network connectors:

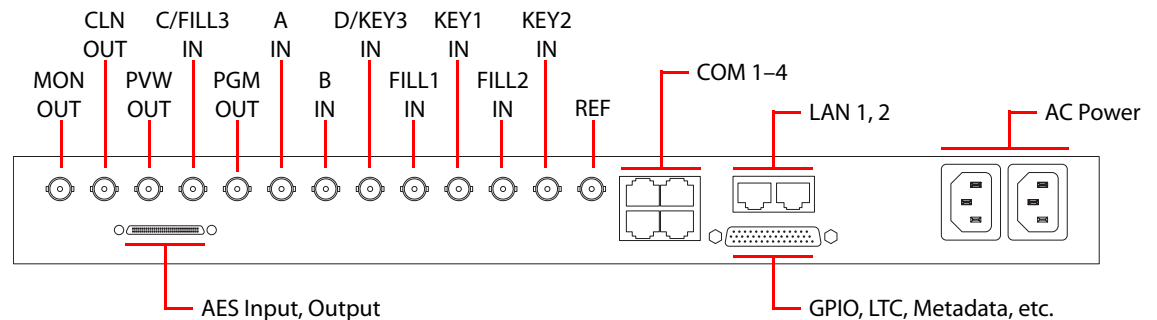

Inputs and outputs of the Imagestore 750 include:

Four SDI inputs, A–D.

Two external keyer pairs (fill and key). Inputs C and D can be used for a third keyer pair.

A GPIO connector that supports 16 GPIO ports (each configurable as an input or an output), LTC, and Dolby metadata.

16 AES inputs and 16 AES outputs.

Four SDI outputs (program, preview, clean-feed, and monitor).

There are also 4 COM ports (supporting automation) and 2 Ethernet ports.

1. The master control system can control LGK-3901s, DSK-3901s, and ISM-3901s. The master control system treats these transition processors as if they were Imagestore 750s with reduced functions.

## Conceptual Model

This diagram shows the Imagestore 750's native conceptual model:

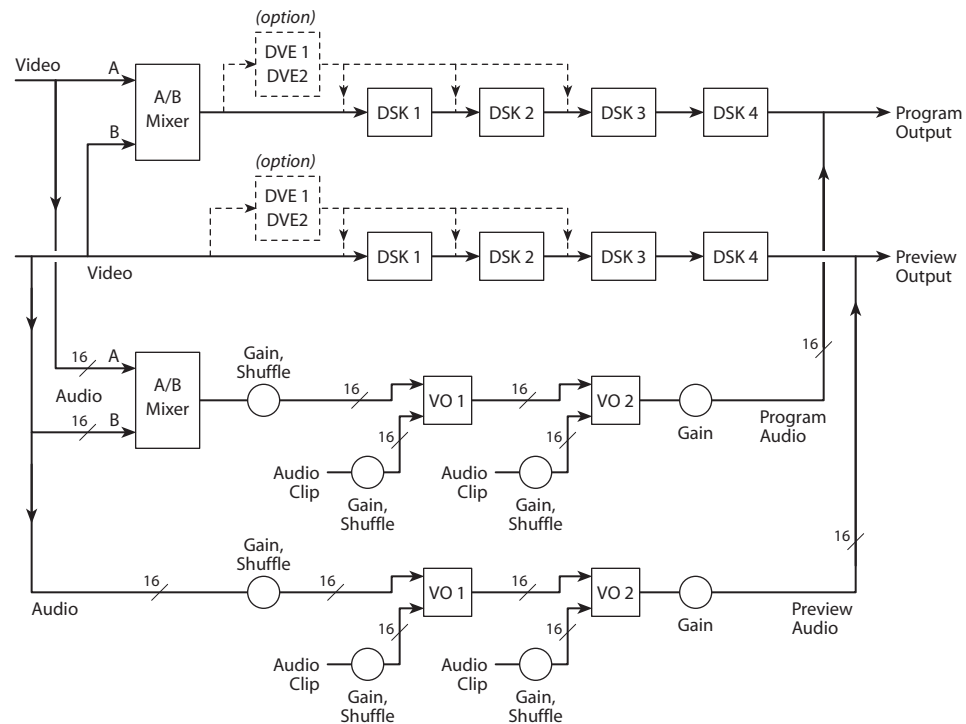

There are two video processing paths, program and preview. Each includes 4 downstream keyers (DSKs) and an optional DVE processor. (Preview, in the iMC master control system is generally called preset.)

After audio is disembodied, the audio processing path includes an A/B mixer for 16 audio channels and two voice-over processors, also for the 16 channels. Audio is re-embedded in program and preview audio after processing.

The Imagestore 750 also includes a clean-feed (video) output and a (video) monitor output. There are many selectable tap locations for these outputs.

- ▲ The LGK-3901 and ISM-3901 have 5 DSKs, but no DVE.
- ▲ The DSK-3901 has 2 DSKs, no DVE, and no internal storage for audio clips or DSKs.

Refer to the *Master Control Reference Manual* for more detail.

## Use in the iMC Master Control System

The master control system adds certain features to the Imagestore 750's software architecture. These features relate to the NV9000 router control system.

- NV9000's IP address.
- PGM bus destination.
- PST bus destination.
- Aux bus destination.
- (Optionally) monitor wall destinations.



A certain version of the Imagestore 750 configuration software is required to support these features. That version is v1.4 at present.

- ▲ Note that in the master control system, the “PGM bus” is the name of an element in an MCE or MCPM. The same holds for the PST bus. The aux bus is part of an MCE. There are no such buses in relation to the Imagestore 750.

These options in the Imagestore 750 configuration software refer to the PGM, PST, and aux **button rows** of panels, which are colloquially called the PGM, PST, and aux buses, respectively.

This diagram illustrates the required connections for Imagestore 750 operation:

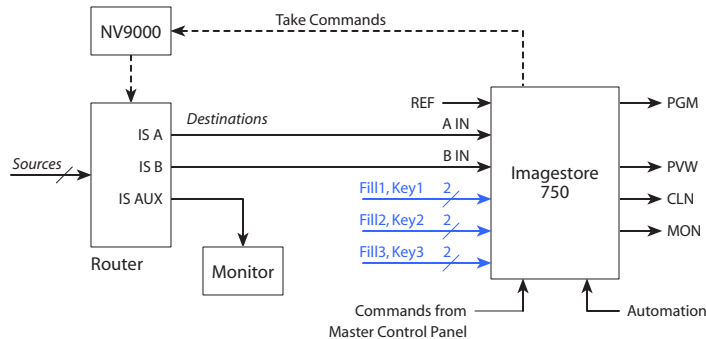

### NV9000's IP Address

The IP address of the NV9000 router control system is an essential part of the Imagestore 750 configuration. Without it, the software cannot configure video and audio sources and the Imagestore 750 cannot function in the master control system.

### PGM and PST Destination

The PGM destination is an NV9000 destination that corresponds to the Imagestore 750's A input. It is destination's video level (if it has more than one level) that is connected to the A input.

Similarly, the PST destination is an NV9000 destination that corresponds to the Imagestore 750's B input. It is destination's video level (if it has more than one level) that is connected to the B input.

Each of the video inputs may have up to 16 embedded audio channels.

### Aux Destination

The aux destination is an NV9000 destination that can be connected to a separate device (such as a video monitor). The aux destination does not connect to the Imagestore 750.

However, the Imagestore 750 can issue commands to the NV9000 to perform takes for main source buttons pressed on the aux button row of a master control panel to the designated “aux” destination.

In that way, the panel operator who is controlling an Imagestore 750 has an “extra” set of controls (i.e., the aux buttons) with which to view sources on a monitor or to route sources to some other device for some other purpose.

## Fill and Key

The Imagestore 750 has 4 downstream keyers (DSKs). Each DSK can apply stored keys or any of 3 external keys to the video signal upstream. Each key comprises a fill and key signal. They keys are governed by “CGT” (clip, gain, transparency) parameters. (The Fill3 and Key3 inputs are the same as the C and D inputs.)

It is possible to connect an external keyer input to an Intuition XG processor.

## Source Groups

The Imagestore 750 configurator allows the definition of source groups. A source group is a named set of sources. Master control operators can select different sets of sources using ‘Group Select’ buttons.

Each group maps NV9000 sources to consecutive integers starting at 1. The group can have “holes” — you need not assign a source to an integer.

When the master control operator selects a source group, the sources in the group are mapped to the preset, program, and aux buttons of the panel one-to-one. The button at the left corresponds to source 1, button 2 to source 2, and so on. The mapping is limited by the minimum of the number of main source buttons or the number of sources in the group. Where the group has holes, the main source buttons are disabled.

The source groups themselves are named and listed in the Imagestore 750 configurator. The source groups have an implicit numbering and ordering *starting at 0*. When the panel configurator defines a ‘Group Select’ button, the group selected by the button is identified by its number in the ordering within the Imagestore 750 configurator: 0, 1, 2, 3 and so on.

## Monitor Wall

A panel operator can select different groups of main sources. A channel change or an automation command can also cause a change in the current set of main sources. Your system’s monitor wall (if it has one) can display the sources available to the operator. The operator’s panel must be configured with the NV9000 destinations that correspond to individual monitors in the monitor wall.

When an operator selects a source group, or when a channel change occurs, or when automation changes the current sources, the Imagestore 750 issues a set of take commands routing the sources in the source group to the corresponding destinations driving the monitors.

Because the iMC-Panel-200 and iMC-Panel-GUI have potentially 16 source buttons and the iMC-Panel-300 has potentially 24 source buttons, up to 24 NV9000 destinations may be reserved for the monitor wall. The monitor wall of course can display hundreds of sources. Master control can use up to 24 of them and cause the sources displayed on those to change when the operator changes sources.

The monitor wall can also display the current Imagestore 750’s outputs (program, preset, etc.). These also can change dynamically.

## Traditional vs. PresStation Preset Tally

Some operators like “PresStation” method of arming DVEs, DSKs, and voice-overs on the preset bus. Other operators like the traditional method (which is used for MCEs and MCPMs).

In “PresStation mode,” the preset row’s DSK, DVE, and voice-over buttons light when they are armed (for the next transition) and are dimmed when they are disarmed.

In the “traditional mode,” the DSK, DVE, and voice-over buttons light when the actively contribute to the preset video output and are dimmed when they do not contribute, regardless of whether they are armed.

There is a checkbox option available under the [Advanced](#) configuration page (on page 166). If you check the ‘Enable Traditional PST Tally’ checkbox, the panel will operate using the traditional method. Otherwise, the panel will use the “PresStation” method.

If you check the ‘Enable Traditional PST Tally’ checkbox, it is imperative that the ‘Active Preview Keyers’ parameter of the Imagestore 750 configuration be set to true. In addition, if the panel you are configuring uses DVEs, set the ‘Active Preview DVE’ parameter of the Imagestore 750 configuration to true.

Refer to the *Imagestore 750 Reference Manual* for details.

## Configuration Editor Overview

The MCS Panel Configuration Editor is the tool with which you configure master control panels. You create and edit configurations on your PC and store them in your PC’s file system.

You read and write the configurations you created to and from control panels.

When you create a configuration, you designate the type of panel. Thereafter, the configuration is “locked” to that panel type.

Further, the configuration editor can configure certain panels (the iMC-Panel-100, iMC-Panel-200, iMC-Panel-300, and iMC-Panel-GUI) to control Imagestore 750s as well as MCEs and MCPMs. The Imagestore 750 controls are different from controls for MCEs and MCPMs.

The principal functions of a configuration are:

To enumerate the channels that the panel controls.

To assign functions to definable panel buttons.

To establish the router categories assigned to the panel’s router menu (for MCEs and MCPMs).

To establish the router destinations assigned to a monitor wall (for Imagestore 750s).

To specify panel default states.

To read configurations from, and write configurations to, control panels.

Optionally, to establish control over Kaleido-X multi-viewers.

Panels (of the same type) in a master control system can all have different configurations or they can have the same configuration. Generally, there will be some amount of configuration overlap — channel definitions, for example — and some differences.

Different panel types will necessarily have different configurations, but may all control the same channels and have button functions in common.



# 3 Control Panels

Chapter 3 provides a brief overview of the control panels that the MCS Panel Configuration Editor configures.

## Topics

|                                      |    |
|--------------------------------------|----|
| <i>Panel Comparison</i> .....        | 24 |
| <i>iMC-Panel-200 Summary</i> .....   | 25 |
| <i>iMC-Panel-300 Summary</i> .....   | 31 |
| <i>iMC-Panel-100 Summary</i> .....   | 39 |
| <i>iMC-Panel-GUI Summary</i> .....   | 45 |
| <i>CECP Summary</i> .....            | 50 |
| <i>FCEP Summary</i> .....            | 56 |
| <i>CECP GUI Summary</i> .....        | 61 |
| <i>CFCP Summary</i> .....            | 64 |
| <i>FFCP Summary</i> .....            | 69 |
| <i>PC GUI Summary</i> .....          | 72 |
| <i>Aux/Preview GUI Summary</i> ..... | 75 |
| <i>SCP Summary</i> .....             | 78 |
| <i>Misc. Topics</i> .....            | 81 |

(The CECP M1 is discussed in the CECP Summary.)

## Panel Comparison

The MCS Panel Configuration Editor configures these master control panels:

| Panel           | Button rows         | IS750 Support | MCE Support | Remarks   |
|-----------------|---------------------|---------------|-------------|---|
| iMC-Panel-300   | 4 rows × 24 buttons | Yes           | Full        | Full-size panel, joystick, large touchscreen, audio controls  |
| iMC-Panel-200   | 4 rows × 16 buttons | Yes           | Full        | Compact panel, joystick, large touchscreen, audio controls  |
| iMC-Panel-100   | 4 rows × 16 buttons | Yes           | Full        | Rack-mount panel, large touchscreen, audio controls   |
| iMC-Panel-GUI   | 4 rows × 16 buttons | Yes           | Full        | GUI, emulating the iMC-Panel-200, audio controls  |
| CECP            | 4 rows × 16 buttons | No            | Full        | Compact panel, joystick, large touchscreen, audio controls  |
| FECP            | 4 rows × 24 buttons | No            | Full        | Full-size panel, joystick, large touchscreen, audio controls  |
| CECP GUI        | 4 rows × 16 buttons | No            | Full        | GUI, emulating the CECP.  |
| CFCP            | 2 rows × 16 buttons | No            | Partial     | Compact panel, large touchscreen, audio controls  |
| FFCP            | 2 rows × 24 buttons | No            | Partial     | Full-size panel, large touchscreen, audio controls  |
| PC GUI          | 2 rows × 16 buttons | No            | Partial     | GUI, emulating the FFCP.  |
| CECP M1         | 3 rows × 16 buttons | No            | Partial     | Compact panel, large touchscreen. Without joystick or preview button row, audio controls. Has extra audio metering input. |
| SCP             | 2 rows × 16 buttons | No            | Partial     | 3RU rack-mounted panel, no LCD but buttons support hierarchical menu selection, audio controls                            |
| Aux/Preview GUI | 2 rows × 16 buttons | No            | Partial     | A variant of the CECP GUI that is without program and preset buttons.   |

The iMC-Panel-300 was derived from the FECP.

The iMC-Panel-200 was derived from the CECP.

The iMC-Panel-100 was derived from the SCP and has an added display.

The iMC-Panel-GUI was derived from the CECP GUI.

The iMC-Panel-200 and the CECP share configuration pages in the configuration editor.

The iMC-Panel-300 and the FECP share configuration pages in the configuration editor.

The iMC-Panel-GUI and the CECP GUI share configuration pages in the configuration editor.

The four iMC panels can be configured to control either an Imagestore 750 or an MCE or an MCPM. Although the CECP, FECP, and CECP GUI cannot control an Imagestore 750, their configuration pages have the Imagestore 750 option. You will have to remember that, although you can configure the Imagestore 750 options, the CECP, FECP, and CECP GUI *do not use them*.

The iMC-Panel-GUI, CECP GUI, and Aux/Preview GUI run on PCs under Windows XP or Windows 7. The PC GUI runs under Windows XP, but not under Windows 7.

The configuration files for the iMC-Panel-GUI, the CECP GUI, and the Aux/Preview GUI all use the same fixed name: `cecp_gui.ui.cfg`. These 3 GUIs must reside in different folders with distinct configuration files if they are to execute on the same PC.

The Aux/Preview GUI and the CECP GUI are actually the same product — with different configuration files.

## iMC-Panel-200 Summary

The iMC-Panel-200 is a configurable master control panel, 19.7" wide × 6.96" high × 20.21" deep. Rear connectors extend the depth 0.67". The iMC-Panel-200 requires at least 2–3" clearance at the rear for cables. The iMC-Panel-200 sits on a console or desktop.

Figure 3-1 shows the location of the iMC-Panel-200's touchscreen, function buttons, and controls.



Fig. 3-1: Sections of the iMC-Panel-200 (Shown Controlling an Imagestore 750)

### Sections of the iMC-Panel-200

|    |  |    |  |    |                                   |
|----|--|----|--|----|-----------------------------------|
| 1  | <a href="#">Program and preset buttons</a> | 2  | <a href="#">Preview/user buttons</a>   | 3  | <a href="#">Aux/user buttons</a>  |
| 4  | <a href="#">LCD touchscreen</a>            | 5  | <a href="#">Configurable buttons</a>   | 6  | <a href="#">Joystick</a>          |
| 7  | <a href="#">Touchscreen knobs</a>          | 8  | <a href="#">Audio monitor knobs</a>    | 9  | <a href="#">Audio level knobs</a> |
| 10 | <a href="#">Transition control buttons</a> | 11 | <a href="#">System control buttons</a> | 12 | <a href="#">Transition button</a> |

The iMC-Panel-200 can control Imagestore 750s, MCEs, and MCPMs. The appearance of the menus on the touchscreen and the meaning of the buttons on the panel change when the operator switches from an MCE or MCPM to an Imagestore 750 or vice versa.

Following are brief descriptions of each section:

#### 1 Program and preset buttons

The iMC-Panel-200 has 16 program buttons and 16 preset buttons. The functions of the buttons differ when the panel is controlling an MCE or MCPM or an Imagestore 750.

For MCEs and MCPMs:

The 16 *program* buttons includes main source buttons (at the left) and “layer” buttons (at the right). The layer buttons can be configured as video effects, audio overs, or XG keyer layers. Whatever main source, video effects, audio overs, or XG keyer layers are selected on the program bus form the *program* output of the MCPM that is currently controlled by the iMC-Panel-200.

The *preset* buttons allows you to set up the state of the program output that will exist after the next transition.

The preset bus, program bus, and preview bus all have the same button functions.

(See also [Bank Select](#) on page 144.)

*For Imagestore 750s:*

The 16 buttons of the program bus includes *up to* 16 main source buttons (at the left) and *up to* 16 “layer” buttons (at the right). The layer buttons can include up to 4 DVE, 2 voice-overs, 4 DSKs (downstream keyers), and 8 XG keyer layers.

Whatever main source, DVE, voice-overs, or DSKs are selected on the program bus form the *program* output of the Imagestore 750 that is currently controlled by the iMC-Panel-200.

The *preset* bus allows you to set up the state of the program output that will exist after the next transition.

The preset row and program row both have the same button functions. Note that the preset buttons correspond the Imagestore’s *preview* output.

(See also the [Group Select](#) buttons on page 144.)

## 2 Preview/user buttons

The iMC-Panel-200 has 16 preview/user buttons. The functions of the buttons differ when the panel is controlling an MCE or MCPM or an Imagestore 750.

*For MCPMs:*

The preview/user buttons are disabled.

*For MCEs:*

The preview/user buttons are enabled (active) only when the iMC-Panel-200 controls an MCE.

The preview/user buttons allow a master control operator to preview (i.e., experiment with) main sources and video effects without interfering with on-air programming or with automation.

The preview/user buttons are the same as the program and preset buttons.

*For Imagestore 750s:*

The preview/user buttons are always enabled and provide customer-configurable functions. See [Preview/User Row](#) on page 176.

## 3 Aux/user buttons

The iMC-Panel-200 has 16 aux/user buttons. The functions of the buttons differ when the panel is controlling an MCE or MCPM or an Imagestore 750.

This button row contains *aux* and *aux delegate* buttons when the panel is controlling an MCE and contains *aux* and customer-definable function buttons when the panel is controlling an Imagestore 750. The button row is disabled when the panel is controlling an MCPM.



For MCEs, the aux buttons consist of the same main sources that appear on the preset, program, and preview buses plus up to 6 “aux delegate” buttons. The different delegate buttons determine the function of the aux bus. The aux bus might or might not be related to the aux outputs of an MCE, depending on configuration. See [Aux Delegates](#) on page 125.

For Imagestore 750s, the aux buttons consist of the same main sources that appear on the preset and program, buses plus up to 6 customer-definable function buttons, among which are “menu” buttons. See [Aux Row](#) on page 175. (Menu buttons turn menus on and off.)

#### 4 LCD touchscreen

The content of the LCD touchscreen differs when the panel is controlling an MCE or MCPM or an Imagestore 750.

For an MCE or MCPM, you can control functions such as keyer settings, squeezeback settings and audio channels.

For an Imagestore 750, you can control functions such as downstream keyer (DSK) settings, DVE settings and audio channels.

Associated with the touchscreen are 8 rotary knobs for adjustment of parameters.

#### 5 Configurable buttons

The configurable button section includes 16 buttons with assignable legends. The content of the configurable button section differs when the panel is controlling an MCE or MCPM or an Imagestore 750.

For an MCE or MCPM, the configurable buttons may be programmed to perform functions such as channel selection, GPI triggers, or salvos. Some of these buttons can function as status indicators.

For an Imagestore 750, the configurable buttons may be programmed to perform functions such as channel selection, GPI macros, or menu selection.

Some of these buttons can function as status indicators.

#### 6 Joystick

The use of the joystick differs when the panel is controlling an MCE or MCPM or an Imagestore 750.

For an MCE or MCPM, the joystick allows fine visual adjustment of squeezeback images for the MCPM-SDHD and MCEs. It also allows the adjustment of other video effects and allows operators to scroll data displays, such as a panel log report.

For an Imagestore 750, the joystick allows the operator to adjust certain parameters, such as DSK position, visually.

The joystick has 2 buttons and a knurled cylinder that the operator turns to control a third axis.

#### 7 Touchscreen knobs

The 8 knobs under the touchscreen allow the operator to adjust menu parameters. Not all knobs are active all the time. When a knob is active, the touchscreen shows a colored indicator near the knob.

#### 8 Audio monitor knobs

The functions of the monitor knobs differ when the panel is controlling an MCE or MCPM or an Imagestore 750. The two knobs are labeled ‘Mon A/CLN Gain’ and ‘Mon B/MON gain’.

An MCE or MCPM has 2 audio monitor buses, A and B. When the panel is controlling an MCE or an MCPM, the knobs allow you to increase or decrease the levels of audio monitor A or B.

An Imagestore 750 has a *clean* (CLN) output and a *monitor* (MON) output. When the panel is controlling an Imagestore 750, the knobs allow you to increase or decrease the gain of its clean output or the monitor output.

#### 9 Audio level knobs

The functions of the audio level knobs differ when the panel is controlling an MCE or MCPM or an Imagestore 750. The two knobs are labeled 'Duck Level' and 'Gain/Voice-Over Preset'.

For an MCE or MCPM, the 'Duck Level' knob adjusts the audio output level of the source selected on the program bus and the 'Gain/Voice-Over Preset' knobs adjusts the ratio of the audio over to the main source audio for the program bus. (Operators use the menus to change the audio levels of the preset bus.)

For an Imagestore 750, the 'Duck Level' knob adjusts the "duck level" of the source selected on program output and the 'Gain/Voice-Over Preset' knobs adjusts the voice-over level of program output.

#### 10 Transition control buttons

The 8 buttons in this section are, by default, transition buttons, but they are also configurable.

The functions of these buttons differ when the panel is controlling an MCE or MCPM or an Imagestore 750. See [Bottom Row Layout](#) (page 110, for MCEs and MCPMs) and [Bottom Row Layout](#) (page 164, for Imagestore 750s).

#### 11 System control buttons

There are 3 buttons in the system control section of the iMC-Panel-200. Their functions differ when the panel is controlling an MCE or MCPM or an Imagestore 750. See [Bottom Row Layout](#) (page 110, for MCEs and MCPMs) and [Bottom Row Layout](#) (page 164, for Imagestore 750s).

For an MCE or MCPM, they are 'Panel Lock', 'Auto Off', and 'Fade to Black' by default. Each of these buttons can be configured to have another function, however, or no function at all.

For an Imagestore 750, they are configurable and have no defaults.

#### 12 Transition button

The transition button displays the transition type (as a graphic) and the transition rate (in text). It is almost always bright orange, but red during pre-roll transitions.

Pressing the transition button initiates a transition in the MCE, MCPM, or Imagestore 750, according to the iMC-Panel-200 setup. Operators can change the transition rate and type using the touchscreen menu.

## iMC-Panel-200 Buttons

Buttons appear in several colors and 3 brightness levels: off, low-tally, and high-tally.

Buttons allow the operator to choose sources and video effects and to make menu selections. Some buttons display status. Pressing a button usually selects something. However, nothing happens when the operator pushes a button that is disabled or off and nothing happens when the operator pushes a button that merely displays status.

Panel buttons are large and appear in several colors (green, amber, red, blue, white, violet, and aqua) and 3 brightness levels: off, low-tally, and high-tally. They are dynamically re-legendable, displaying 3 lines of text, 8 characters per line. (The text might be blank.)

In addition to these colors, a button can be dark (that is, off, or having no color). High-tally red and high-tally amber usually indicate warnings.

The following color scheme usually applies. Exceptions will be noted.

- Non-selected state: low tally — green, blue, violet, or orange.
- Selected state: high tally — green, blue, violet, orange, or red.
- Status: green, white, amber, red. (Status buttons do nothing when pressed.)
- When the panel is controlling an Imagestore 750, menu buttons are aqua when selected.

Some buttons are *toggles*. Pressing a deselected toggle button will cause it to become selected. Pressing a selected toggle button will make it deselected.

Some groups of buttons operate as a mutually exclusive set. Pressing a deselected button will cause it to become selected and all other buttons in the set to become deselected. There are two types of mutually exclusive buttons:

- 1 Pressing a selected button makes it deselected. (All other buttons in the set remain deselected.)
- 2 Pressing a selected button has no effect: the button remains selected.

## iMC-Panel-200 Knobs

Turning a knob clockwise increases the associated value until the maximum value is reached. Turning the knob counter-clockwise decreases the associated value until the minimum value is reached. Turning the knob beyond its value limits has no effect.

An indicator on the touchscreen illuminates just above any of the 8 touchscreen knobs when it is enabled.

## iMC-Panel-200 Touchscreen

The touchscreen and its 8 associated knobs provides a menu system. The use of the touchscreen differs when the panel is controlling an MCE or MCPM or an Imagestore 750.

### MCE and MCPM

For MCEs and MCPMs, the touchscreen lets operators do the following:

- Select a channel (i.e., an MCPM, MCE, or an Imagestore 750).
- Select a main source or an over source.
- Choose a router source.
- Select a video effect and alter its settings.
- Manipulate audio.
- Change transition rates.
- Perform panel maintenance and updates.
- View status and error messages.
- View “live levels” (MCEs only).

The touchscreen provides scroll bars for list selection.

## Imagestore 750

For Imagestore 750s, the touchscreen lets operators do the following:

- Select a channel (i.e., an MCPM, MCE, or an Imagestore 750).
- Select a main source.
- Select a downstream keyer (DSK) and alter its settings.
- Select a DVE and alter its settings.
- Manipulate audio.
- Change transition rates.
- Perform panel maintenance and updates.
- View status and error messages.
- Arm or “fire” macros.
- Load media into DSKs and XG keyer layers.

The touchscreen provide scroll bars for list selection.

## iMC-Panel-200 Connectors

At the rear of the iMC-Panel-200 are 2 power connectors, one Ethernet connector, a USB port, a fan, an aux port, a GPI/alarm connector, and an audio metering input:



Fig. 3-2: iMC-Panel-200 (rear view)

The USB port and the aux port are *reserved for future development*.

## Power

There are 2 AC connectors, PS1 and PS2, for redundancy. You need not use both if you are not concerned with redundancy.

## Ethernet

The iMC-Panel-200 has one RJ-45 Ethernet port. The iMC-Panel-200 connects to the Ethernet switch of the master control network.

It is on this network that the iMC-Panel-200 communicates with MCPMs and with the configuration software. You (or your system administrator) must provide a unique IP address for the iMC-Panel-200. Use the Panel ID menu under the Panel Menu to set the IP address, IP subnet mask, and gateway IP address. The default IP address is 192.168.7.100 and the subnet mask must always be 255.255.255.0.

## GPI/Alarm

The iMC-Panel-200 has a DB25 connector that supports GPI inputs, GPI outputs, and alarms:

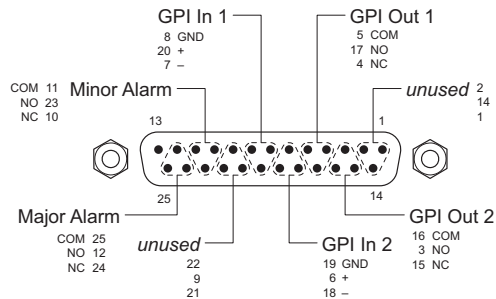

Refer to the GPI section in one of the two iMC-Panel-200 operator's guides for connection information. Also see [Panel GPI](#) on page 193.

## Audio Metering Input

The audio metering output of an MCE is a suitable source for this input.

In general, the panel's audio metering inputs are **not** related to the panel's audio metering controls. However, when the metering inputs are connected to the MCE under control, the metering controls **are** related.

The 'SD/HD Input' connector (BNC) is the panel's audio metering input. This input drives the panel's "live levels" display. As the label implies, the input can be either SD or HD video with up to 16 channels of audio embedded. The live levels display shows the audio levels of all 16 channels in real time.

## iMC-Panel-300 Summary

The iMC-Panel-300 is a configurable master control panel, 28.25" wide × 6.96" high × 20.14" deep. It has only one mounting option: it sits on a console or desk top.

Arrayed on the panel are 140 color-coded LCD buttons, a touchscreen menu (LCD) with 8 associated control knobs, 2 white toggle buttons, 4 audio knobs (a.k.a. rotary encoders), and a joystick. Each LCD button shows 3 lines of text, 8 characters per line. The LCD buttons are either green, amber, red, blue, white, or violet, —off, low-tally, or high-tally. Red is generally used to indicate an error condition. The surface of the iMC-Panel-300 is light gray and dark gray.

Figure 3-3 shows the location of the iMC-Panel-300's touchscreen, function buttons, and controls:



Fig. 3-3: Sections of the FECP (Shown Controlling an Imagestore 750)

#### Sections of the iMC-Panel-300

|   |   |    |  |
|---|---|----|--|
| 1 | <a href="#">Configurable buttons</a>        | 7  | <a href="#">Preview/user buttons</a>               |
| 2 | <a href="#">Touchscreen</a>                 | 8  | <a href="#">Aux/user buttons</a>                   |
| 3 | <a href="#">Joystick</a>                    | 9  | <a href="#">Program and preset "layer" buttons</a> |
| 4 | <a href="#">Audio monitor/meter control</a> | 10 | <a href="#">Transition control buttons</a>         |
| 5 | <a href="#">Program audio control</a>       | 11 | <a href="#">System control buttons</a>             |
| 6 | <a href="#">Program and preset sources</a>  | 12 | <a href="#">Transition button</a>                  |

At the rear of the panel are 2 power connections, an Ethernet port, a USB port, a 'CP Aux' connector (DB15) used for the optional TLA, and a GPI/alarm connector (DB25), and an audio metering input.

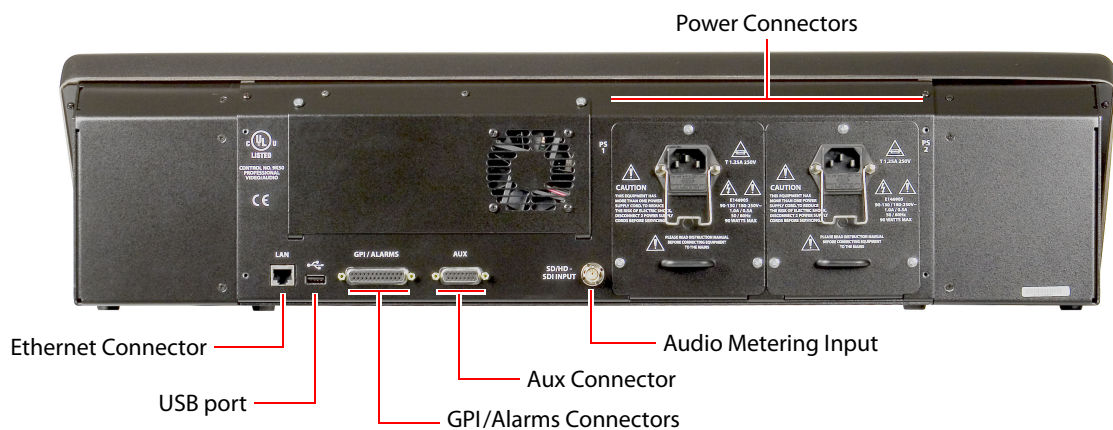

Fig. 3-4: iMC-Panel-300 (Rear)

## iMC-Panel-300 Buttons

Panel buttons are large and appear in several colors (green, amber, red, blue, white, violet, and aqua) and 3 brightness levels: off, low-tally, and high-tally. They are dynamically re-legendable, displaying 3 lines of text, 8 characters per line. (The text might be blank.)

In addition to these colors, a button can be dark (that is, off, or having no color). High-tally red and high-tally amber usually indicate warnings.

The following color scheme usually applies. Exceptions will be noted.

- Non-selected state: low tally — green, blue, violet, or orange.
- Selected state: high tally — green, blue, violet, orange, or red.
- Status: green, white, amber, red. (Status buttons do nothing when pressed.)
- When the panel is controlling an Imagestore 750, menu buttons are aqua when selected.

The buttons allow you to select channels, choose sources, options, video effects, and audio overs, and perform other functions. Some buttons can serve as status buttons.

Some buttons are *toggles*. Pressing a deselected toggle button will cause it to become selected. Pressing a selected toggle button will make it deselected.

Some groups of buttons operate as a mutually exclusive set. Pressing a deselected button will cause it to become selected and all other buttons in the set to become deselected. There are two types of mutually exclusive buttons:

- 1 Pressing a selected button makes it deselected. (All other buttons in the set remain deselected.)
- 2 Pressing a selected button leaves the button selected.

The iMC-Panel-300 has a menu system built into its LCD touchscreen. It is through the menu that you can adjust operating parameters such as audio levels and keyer settings.

The iMC-Panel-300's "Transition" button (orange) is large and obvious.

## iMC-Panel-300 Knobs

Turning a knob clockwise increases the associated value until the maximum value is reached. Turning the knob counter-clockwise decreases the associated value until the minimum value is reached. After you reach either extremity, turning the knob has no effect.

An indicator on the touchscreen illuminates just above any of the 8 touchscreen knobs when it is enabled.

## iMC-Panel-300 Touchscreen

The touchscreen and its 8 associated knobs provides a menu system. The use of the touchscreen differs when the panel is controlling an MCE or MCPM or an Imagestore 750.

### MCE and MCPM

For MCEs and MCPMs, the touchscreen lets operators do the following:

- Select a channel (i.e., an MCPM, MCE, or an Imagestore 750).
- Select a main source or an over source.
- Choose a router source.

- Select a video effect and alter its settings.
- Manipulate audio.
- Change transition rates.
- Perform panel maintenance and updates.
- View status and error messages.
- View “live levels” (MCEs only).

The touchscreen provides scroll bars for list selection.

### **Imagestore 750**

For Imagestore 750s, the touchscreen lets operators do the following:

- Select a channel (i.e., an MCPM, MCE, or an Imagestore 750).
- Select a main source.
- Select a downstream keyer (DSK) and alter its settings.
- Select a DVE and alter its settings.
- Manipulate audio.
- Change transition rates.
- Perform panel maintenance and updates.
- View status and error messages.

The touchscreen provide scroll bars for list selection.

### **Functional Sections of the iMC-Panel-300**

Following are brief descriptions of each section. Refer to Figure 3-3 on page 32.

#### 1 Configurable buttons

The configurable button section includes 16 buttons with assignable legends. The content of the configurable button section differs when the panel is controlling an MCE or MCPM or an Imagestore 750.

For an MCE or MCPM, the configurable buttons may be programmed to perform functions such as channel selection, GPI triggers, or salvos. Some of these buttons can function as status indicators.

For an Imagestore 750, the configurable buttons may be programmed to perform functions such as channel selection, GPI macros, or menu selection.

Some of these buttons can function as status indicators.

#### 2 Touchscreen

The content of the LCD touchscreen differs when the panel is controlling an MCE or MCPM or an Imagestore 750.

For an MCE or MCPM, you can control functions such as keyer settings, squeezeback settings and audio channels.

For an Imagestore 750, you can control functions such as downstream keyer (DSK) settings, DVE settings and audio channels.



Associated with the touchscreen are 8 rotary knobs for adjustment of parameters. Not all knobs are active all the time. When a knob is active, the touchscreen shows a colored indicator near the knob.

### 3 Joystick

The use of the joystick differs when the panel is controlling an MCE or MCPM or an Imagestore 750.

For an MCE or MCPM, the joystick allows fine visual adjustment of squeezeback images for the MCPM-SDHD and MCEs. It also allows the adjustment of other video effects and allows operators to scroll data displays, such as a panel log report.

For an Imagestore 750, the joystick allows you to control certain parameters, such as DSK positioning, more easily.

The joystick has 2 buttons and a knurled cylinder that the operator turns to control a third axis.

### 4 Audio monitor/meter control

The functions of the audio monitor/meter section differ when the panel is controlling an MCE or MCPM or an Imagestore 750.

An MCE or MCPM has 2 audio monitor buses, A and B, and a metering bus. When the panel is controlling an MCE or an MCPM, the controls allow you to

- Select the source for monitor A, monitor B, and the metering bus. (The source can be program audio, preset audio, preview audio, aux audio, or "off-air" audio.)
- Adjust the gain of the monitor A or monitor B output.
- Dim the monitor A or monitor B output by a configurable amount.

An Imagestore 750 has a *clean* (CLN) output and a *monitor* (MON) output. When the panel is controlling an Imagestore 750, the controls allow you to

- Adjust the gain of the clean output or the monitor output.
- Dim the clean output or the monitor output by a configurable amount.

For an Imagestore 750, the buttons in this section are customer-definable.

### 5 Program audio control

The functions of the audio level knobs differ when the panel is controlling an MCE or MCPM or an Imagestore 750. The two knobs are labeled 'Duck Level' and 'Gain/Voice-Over Preset'.

For an MCE or MCPM, the 'Duck Level' knob adjusts the audio output level of the source selected on the program bus and the 'Gain/Voice-Over Preset' knobs adjusts the ratio of the audio over to the main source audio for the program bus.

(Operators use the menus to change the audio levels of the preset bus.)

For an Imagestore 750, the 'Duck Level' knob adjusts the "duck level" of the source selected on program output and the 'Gain/Voice-Over Preset' knobs adjusts the voice-over level of program output.

#### 6 Program and preset sources

The iMC-Panel-300 has 24 program buttons and 24 preset buttons. The functions of the buttons differ when the panel is controlling an MCE or MCPM or an Imagestore 750.

*For MCEs and MCPMs:*

The 24 *program* buttons includes *up to* 16 main source buttons (at the left) and *up to* 12 “layer” buttons (at the right). The layer buttons can be configured as video effects, audio overs, or XG keyer layers.

Whatever main source, video effects, audio overs, or XG keyer layers are selected on the program bus form the *program* output of the MCPM that is currently controlled by the iMC-Panel-300.

The *preset* buttons allows you to set up the state of the program output that will exist after the next transition.

The preset bus and program bus have the same button functions.

*For Imagestore 750s:*

The 24 buttons of the program bus includes *up to* 24 main source buttons (at the left) and *up to* 18 “layer” buttons (at the right). The layer buttons can include up to 4 DVEs, 2 voice-overs, 4 DSKs (downstream keyers), and 8 XG keyer layers.

Whatever main source, DVEs, voice-overs, or DSKs are selected on the program bus form the *program* output of the Imagestore 750 that is currently controlled by the iMC-Panel-300.

The *preset* bus allows you to set up the state of the program output that will exist after the next transition.

The preset row and program row both have the same button functions. Note that the preset buttons correspond the Imagestore’s *preview* output.

#### 7 Preview/user buttons

The iMC-Panel-300 has 24 preview/user buttons. The functions of the buttons differ when the panel is controlling an MCE or MCPM or an Imagestore 750.

*For MCPMs:*

The preview/user row is disabled.

*For MCEs:*

The preview/user row allows a master control operator to *preview* (experiment with) main sources and video effects without interfering with on-air programming or with automation.

*For Imagestore 750s:*

The preview/user row provides customer-definable function buttons, among which are “menu” buttons. See [Preview/User Row](#) on page 176.

(See also the [Group Select](#) button on page 144.)

#### 8 Aux/user buttons

In addition to the program, preset, and preview/user buttons, the iMC-Panel-300 has 24 aux/user buttons. This button row contains *aux* and *aux delegate* buttons when the panel is controlling an MCE and contains *aux* and customer-definable function buttons when the panel is controlling an Imagestore 750. The button row is disabled when the panel is controlling an MCPM.

For MCPMS, the aux/user buttons are disabled.

For MCEs, the aux/user buttons consist of the same main sources that appear on the preset, program, and preview buses plus up to 6 “aux delegate” buttons. The different delegate buttons determine the function of the aux bus. The aux bus might or might not be related to the aux outputs of an MCE, depending on configuration. See [Aux Delegates](#) on page 125.

For Imagestore 750s, the aux buttons consist of the same main sources that appear on the preset and program, buses plus up to 6 customer-definable function buttons, among which are “menu” buttons. See [Aux Row](#) on page 175. (Menu buttons turn menus on and off.)

#### 9 Program and preset “layer” buttons

The layer section is a part of the program/preset bus that allows you to combine video effects, audio overs, and XG keyer layers with your main source selections.

For MCEs and MCPMs, video effects include keyers, logos, and a squeezeback generator. (Some MCPMs do not support all effects. Only MCEs support XG keyer layers.)

For Imagestore 750s, video effects include DVEs and DSKs.

#### 10 Transition control buttons

The 12 buttons in this section are, by default, transition buttons, but they are also configurable.

The functions of these buttons differ when the panel is controlling an MCE or MCPM or an Imagestore 750. See [Bottom Row Layout](#) (page 110, for MCEs and MCPMs) and [Bottom Row Layout](#) (page 164, for Imagestore 750s).

For an Imagestore 750, they are configurable and have no defaults.

#### 11 System control buttons

There are 3 buttons in the system control section of the iMC-Panel-300. Their functions differ when the panel is controlling an MCE or MCPM or an Imagestore 750. See [Bottom Row Layout](#) (page 110, for MCEs and MCPMs) and [Bottom Row Layout](#) (page 164, for Imagestore 750s).

For an MCE or MCPM, they are ‘Panel Lock’, ‘Auto Off’, and ‘Fade to Black’ by default. Each of these buttons can be configured to have another function, however, or no function at all.

For an Imagestore 750, they are configurable and have no defaults.

#### 12 Transition button

The transition button displays the transition type (as a graphic) and the transition rate (in text). It is usually bright orange, but red during pre-roll transitions.

Pressing the transition button initiates a transition in the MCE, MCPM, or Imagestore 750, according to the iMC-Panel-300 setup. Operators can change the transition rate and type using the touchscreen menu.

## iMC-Panel-300 Connectors

At the rear of the iMC-Panel-300 are 2 power connectors, one Ethernet connector, a USB port, an aux connector, a GPI/alarm connector, and an audio metering input. (See Figure 3-4 on page 32.) The USB port and the aux port are *reserved for future development*.

### Power

There are 2 AC connectors, PS1 and PS2, for redundancy. You need not use both if you are not concerned with redundancy.

## Ethernet

The iMC-Panel-300 has one RJ-45 Ethernet port. The iMC-Panel-300 connects to the Ethernet switch of the master control network.

It is on this network that the iMC-Panel-300 communicates with MCPMs and with the configuration software. You (or your system administrator) must provide a unique IP address for the iMC-Panel-300. Use the Panel ID menu under the Panel Menu to set the IP address, IP subnet mask, and gateway IP address. The default IP address is 192.168.7.100 and the subnet mask must always be 255.255.255.0.

## GPI/Alarm

The iMC-Panel-300 has a DB25 connector that supports GPI inputs, GPI outputs, and alarms:

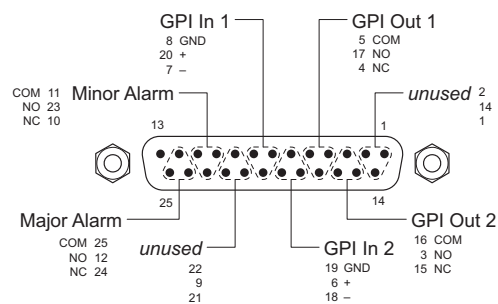

Refer to the GPI section in either of the *iMC-Panel-300 Operator's Guides* for connection information. Also see [Panel GPI](#) on page 193.

## Audio Metering Input

▲ The 'SD/HD Input' connector (BNC) is used only by panels when they are controlling MCEs. When the panel is controlling an MCE, the connector is the panel's audio metering input. This input drives the panel's "live levels" display. As the label implies, the input can be either SD or HD video with up to 16 channels of audio embedded. The live levels display shows the audio levels of all 16 channels in real time.

The audio metering output of an MCE is a suitable source for this input.

In general, the panel's audio metering inputs are **not** related to the panel's audio metering controls. However, when the metering inputs are connected to the MCE under control, the metering controls **are** related.

## iMC-Panel-100 Summary

The iMC-Panel-100 is a configurable master control panel, in two parts: (1) a 3RU button panel (19.0" wide × 5.22" high × 3.70" deep) and (2) a customer-supplied monitor. This is a front view of the button panel:



Miranda provides support for the Planar series of touchscreens. This is the Planar PT1945R:



It has a removable stand and can be wall-mounted. Other VGA monitors can be used. If your choice of a monitor is not a touchscreen, an operator can use a mouse to select items on the screen.

The button panel requires at least 2–3" clearance at the rear for cables. The button panel can be rack-mounted or it can sit on a console or desktop.

Figure 3-1 shows the location of the iMC-Panel-100's touchscreen, function buttons, and controls.

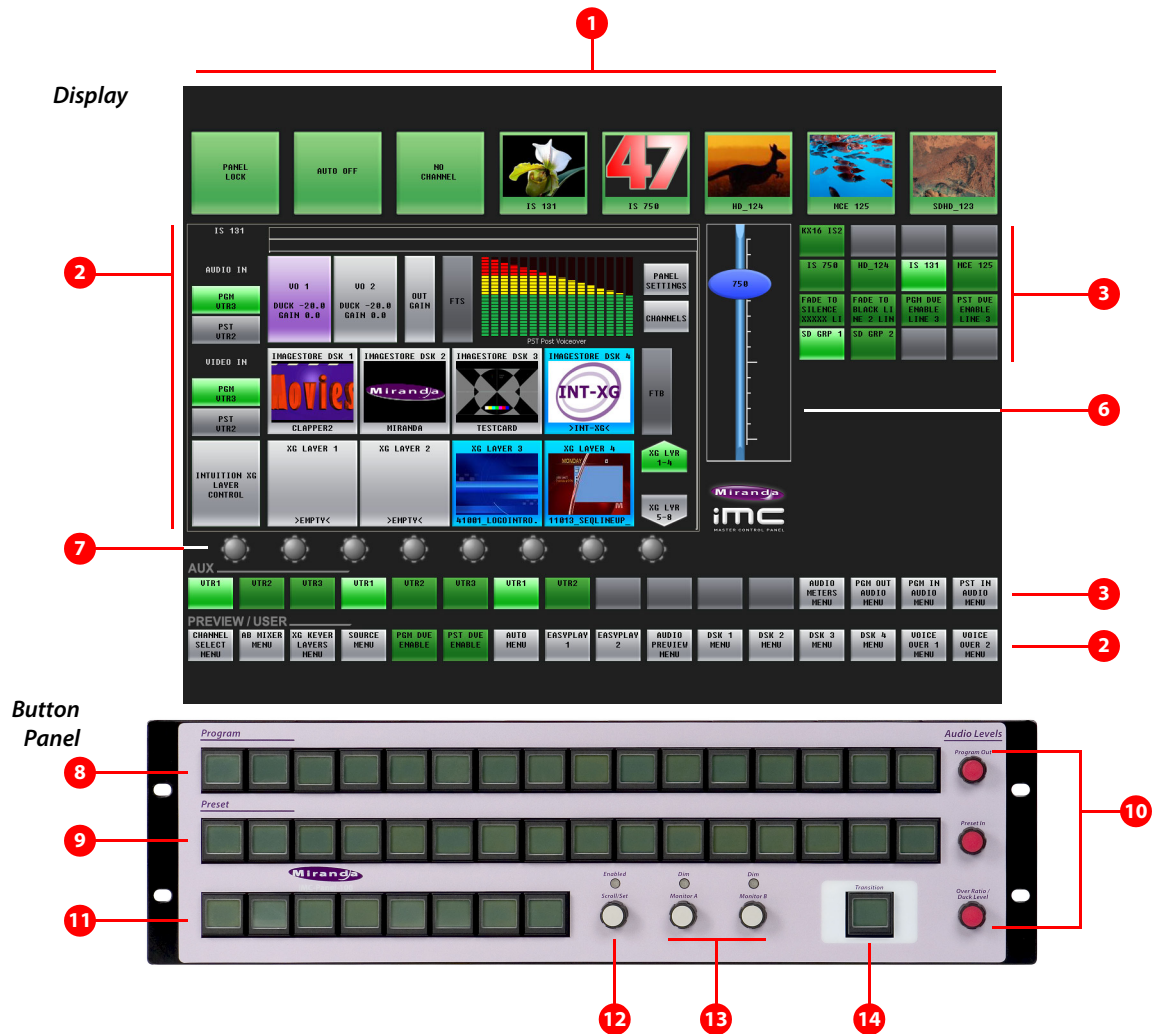

Fig. 3-5: Sections of the iMC-Panel-100 (Shown Controlling an Imagestore 750)

|   |                                      |    |                                      |    |  |
|---|--------------------------------------|----|--------------------------------------|----|--|
| 1 | <a href="#">Top row buttons</a>      | 3  | <a href="#">Aux/user buttons</a>     | 11 | <a href="#">Bottom row buttons</a>     |
| 2 | <a href="#">Menu area</a>            | 2  | <a href="#">Preview/user buttons</a> | 12 | <a href="#">'Scroll/Set' knob</a>      |
| 3 | <a href="#">Configurable buttons</a> | 8  | <a href="#">Program buttons</a>      | 13 | <a href="#">Audio monitoring knobs</a> |
| 6 | <a href="#">Joystick</a>             | 9  | <a href="#">Preset buttons</a>       | 14 | <a href="#">Transition button</a>      |
| 7 | <a href="#">Touchscreen knobs</a>    | 10 | <a href="#">Audio level knobs</a>    |    |  |

Following are brief descriptions of each section:

1 Top row buttons

The 8 large buttons in this row are all customer-configurable buttons. However, the row is designed to accommodate channel selection buttons that have thumbnail images representing the channels.

2 Menu area

Using the menus of the display, you can adjust parameters and control system functions. Associated with the menu are 8 knob "proxies" for adjustment of parameters.

3 Configurable buttons

The configurable button section includes 16 buttons, each of which may be programmed to perform functions such as channel selection, menu selection, or source group selection. Some of these buttons can function as status indicators.

Buttons in other sections of the panel are also configurable.

4 Slider

The slider helps you make certain parameter adjustments such as changes to the size or position of DSKs.

5 Knob "Proxies"

The 8 knob "proxies" under the menu area allow you to adjust menu parameters. Not all of these "knobs" are active all the time. When a knob is active, the menu shows a colored indicator near the knob.

6 Aux/user buttons

When the panel is controlling an Imagestore 750, this button row contains source buttons and customer-definable buttons.

The sources are the same sources as on the preset and program button rows. These buttons allow you to direct a main source to an auxiliary device such as a waveform monitor.

- ▲ If the Imagestore 750 is not configured for controlling an auxiliary device, the aux button row's source buttons are disabled (dark).

7 Preview/user buttons

This row of buttons is a set of "preview" buttons when the panel is controlling an MCE or MCPM and it is a set of customer-definable buttons when the panel is controlling an Imagestore 750. (Among the customer-definable buttons can be "menu" buttons.)

8 Program buttons

The 16 program buttons include main source buttons and "layer" buttons. The layer buttons can be configured as video effects or voice-overs. The number of main sources, video effects, and voice-overs varies according to the panel configuration.

Whatever main source, video effects, and voice-overs are selected on the program buttons form the *program* output of the Imagestore 750 that is currently controlled by the panel.

9 Preset buttons

The preset buttons allows you to set up the state of the program output that will exist after the next transition.

The preset buttons include main source buttons and “layer” buttons. In fact, the preset bus and program bus have the same button functions. The function assigned to a program button is also assigned to the preset button directly beneath it.

Whatever main source, video effects, and voice-overs are selected on the preset bus form the *preview* output of the Imagestore 750 that is currently controlled by the panel.

#### 10 Audio level knobs

The panel has 3 rotary knobs in this section, labeled:

- Program Out

This knob controls either the program output level as a whole or (when a voice-over is active on the program bus) the voice-over level.

- Preset In

This knob controls the preset input level (as a whole).

- Over Ratio / Duck Level

When the panel is controlling an Imagestore 750, this knob controls the audio level of the main source when a voice-over is mixed with program output. (That is called the “duck level.” The term “over ratio” applies only to MCEs and MCPMs.)

#### 11 Bottom row buttons

The buttons in this section are all configurable.

#### 12 ‘Scroll/Set’ knob

When you touch (or click) the knob proxy (under the menu) associated with some parameter (such as voice-over level), the slider appears on the display and the ‘Scroll/Set’ knob of the button panel becomes enabled. You can use either the ‘Scroll/Set’ knob or the slider to adjust the parameter.

#### 13 Audio monitoring knobs

The panel has two rotary knobs in this section, labeled:

- Monitor A

- Monitor B

The knobs apply when the panel is controlling an MCE or an MCPM. The knobs do not apply to Imagestore 750s.

#### 14 Transition button

The transition button displays the transition type (as a graphic) and the transition rate (in text).

‘Cut’ transitions involve no rate and for cut transitions, the button displays no rate text.

The button is bright orange.

Pressing the transition button initiates a transition in the Imagestore 750 according to the panel’s setup.

## iMC-Panel-100 Buttons

Buttons allow the operator to choose sources and video effects and to make menu selections. Some buttons display status. Pressing a button usually selects something. However, nothing happens when the operator pushes a button that is disabled or off and nothing happens when the operator pushes a button that merely displays status.



Panel buttons are large and appear in several colors (green, amber, red, blue, white, violet, and aqua) and 3 brightness levels: off, low-tally, and high-tally. They are dynamically re-legendable, displaying 3 lines of text, 8 characters per line. (The text might be blank.)

In addition to these colors, a button can be dark (that is, off, or having no color). High-tally red and high-tally amber usually indicate warnings.

The following color scheme usually applies. Exceptions will be noted.

- Non-selected state: low tally — green, blue, violet, or orange.
- Selected state: high tally — green, blue, violet, orange, or red.
- Status: green, white, amber, red. (Status buttons do nothing when pressed.)
- When the panel is controlling an Imagestore 750, menu buttons are aqua when selected.

Some buttons are *toggles*. Pressing a deselected toggle button will cause it to become selected. Pressing a selected toggle button will make it deselected.

Some groups of buttons operate as a mutually exclusive set. Pressing a deselected button will cause it to become selected and all other buttons in the set to become deselected. There are two types of mutually exclusive buttons:

- 1 Pressing a selected button makes it deselected. (All other buttons in the set remain deselected.)
- 2 Pressing a selected button has no effect: the button remains selected.

## **iMC-Panel-100 Knobs**

Turning a knob on the button panel clockwise increases the associated value until the maximum value is reached. Turning the knob counter-clockwise decreases the associated value until the minimum value is reached. Turning the knob beyond its value limits has no effect.

The monitor has knob “proxies” below the menu area and when the panel is controlling an MCE or MCPM, additional audio monitor knob proxies at the right. Indicators on the menu illuminate just above the menu knobs when the knobs are enabled. When an operator touches a knob proxy, a slider appears on the screen, and the ‘Scroll/Set’ knob of the button panel is enabled. The operator can then use the slider or the ‘Scroll/Set’ knob to adjust the applicable parameter.

## **iMC-Panel-100 Monitor**

The monitor provides a menu system, the aux/user and preview/user button rows, the “top row” of configurable buttons, and a 4×4 array of configurable buttons. When the panel is controlling an MCE or MCPM, it also provides a set of audio monitor buttons and knob proxies.

The use of the touchscreen differs when the panel is controlling an MCE or MCPM or an Imagestore 750.

### **MCE and MCPM**

For MCEs and MCPMs, the monitor lets operators do the following:

- Select a main source or an over source.
- Choose a router source.
- Select a video effect and alter its settings.
- View “live levels” (MCEs only).

The touchscreen provides scroll bars for list selection.

## Imagestore 750

For Imagestore 750s, the touchscreen lets operators do the following:

- Select a main source.
- Select a downstream keyer (DSK) and alter its settings.
- Select a DVE and alter its settings.
- Arm or “fire” macros.
- Load media into DSKs and XG keyer layers.

The touchscreen provide scroll bars for list selection.

## For Either

- Select a channel (i.e., an MCPM, MCE, or an Imagestore 750).
- Manipulate audio.
- View status and error messages.
- Change transition rates.
- Perform panel maintenance and updates.

## iMC-Panel-100 Connectors

At the rear of the iMC-Panel-100 are 2 power connectors, one Ethernet connector, two USB ports, a fan, an aux port, a GPI/alarm connector, and a VGA connector:

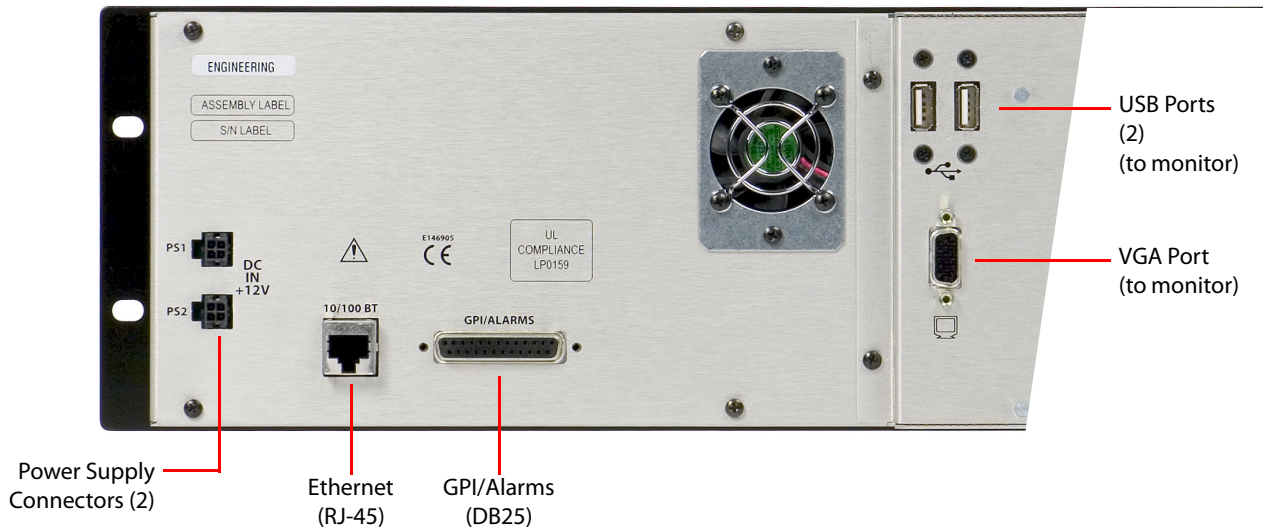

Fig. 3-6: iMC-Panel-100 (rear view)

## USB Ports

The USB ports are for connecting the button panel to the monitor. One USB port is for receiving touchscreen selections. The other port can be used to support a mouse.

## VGA Port

The VGA port connects to and provides the video signals for the monitor.

## Power

There are 2 DC connectors, PS1 and PS2, for redundancy. You need not use both if you are not concerned with redundancy. These connect to a PS0001 external power supply. See the *iMC-Panel-100 User's Guide* for details.

## Ethernet

The iMC-Panel-100 has one RJ-45 Ethernet port. The panel connects to the Ethernet switch of the master control network.

It is on this network that the iMC-Panel-100 communicates with MCPMs, MCEs, Imagestore 750s and with the configuration software. You (or your system administrator) must provide a unique IP address for the iMC-Panel-100. Use the IP settings submenu under the 'Panel' menu to set the IP address, IP subnet mask, and gateway IP address. The default IP address is 192.168.7.100 and the subnet mask must always be 255.255.255.0.

## GPI/Alarm

The iMC-Panel-100 has a DB25 connector that supports GPI inputs, GPI outputs, and alarms:

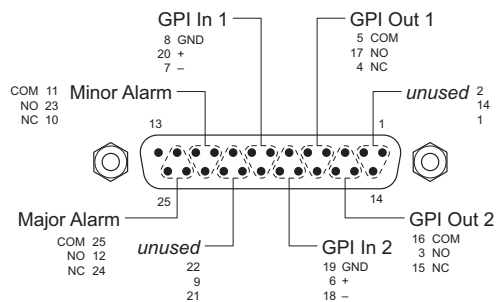

Refer to the GPI section in one of the two iMC-Panel-100 operator's guides for connection information. Also see [Panel GPI](#) on page 193.

## iMC-Panel-GUI Summary

The iMC-Panel-GUI is a software control panel that runs on a PC connected to the master control network. It emulates the functions of the iMC-Panel-200.

Its menu section emulates the touchscreen menu of the iMC-Panel-200. The GUI can be operated either with a mouse on any PC or by finger pressure on a touchscreen PC.

- ▲ The GUI window is 1280×966 pixels and requires a monitor at least that size to function. (Although the GUI window can be resized, doing so prevents access to parts of the GUI.)

Arrayed on this panel are 95 color-coded buttons and a menu with 8 associated menu "knobs." The knobs are graphical of course and emulate the 8 menu knobs of the iMC-Panel-200.

Each button has 3 lines of text, 8 characters per line. Active buttons, like those of the iMC-Panel-200, are either green, red, amber, white, blue, or violet and off, low-tally, or high-tally. Buttons that are unused are just grey. Red generally indicates an error condition. Buttons that are defined, but disabled momentarily, show dimmed text. High-tally buttons are brighter or lighter than buttons that are low-tally.

Figure 3-7 identifies the sections of an iMC-Panel-GUI that is controlling an MCE:

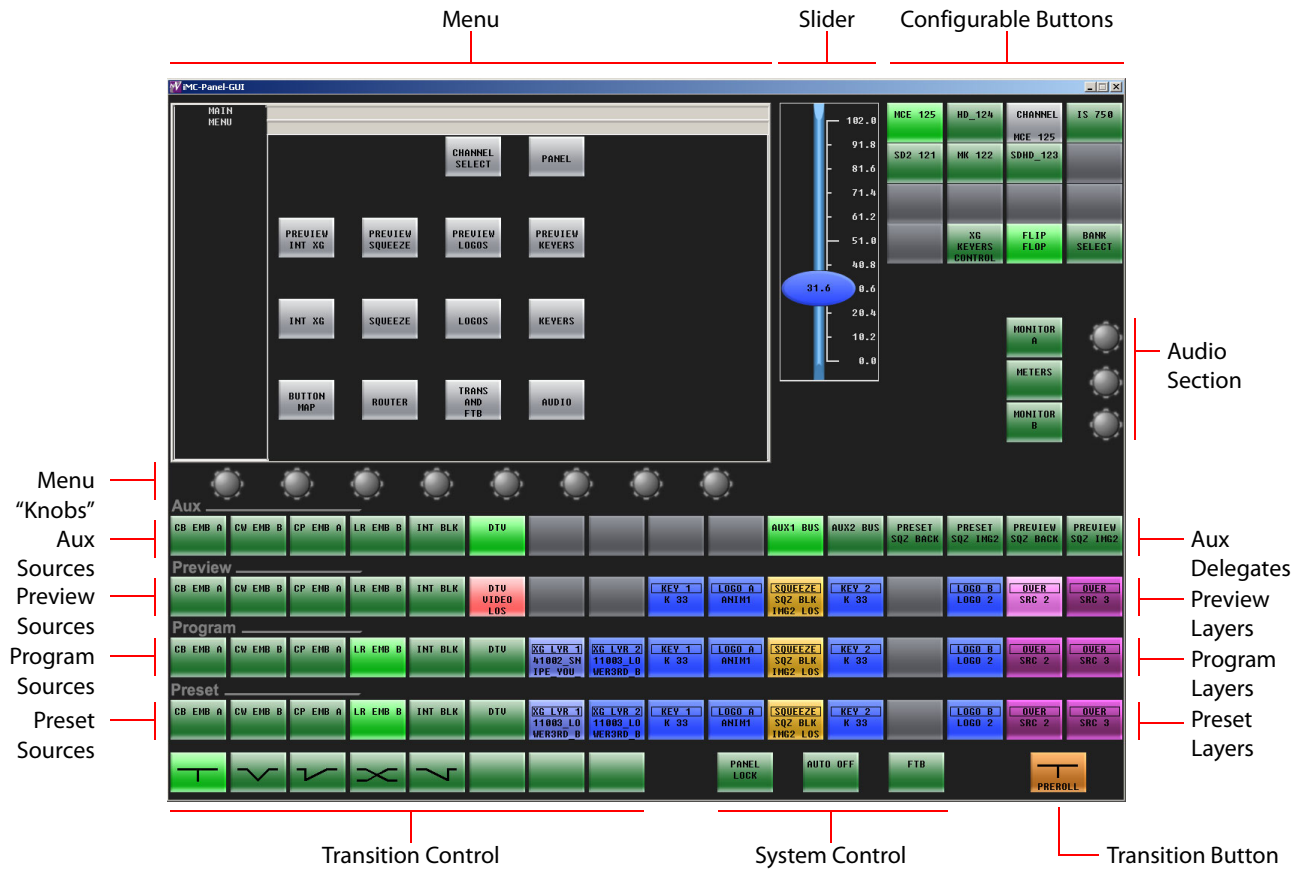

Fig. 3-7: Sections of the iMC-Panel-GUI (Shown Controlling an MCE)

Figure 3-8 identifies the sections of the iMC-Panel-GUI that is controlling an Imagestore 750:

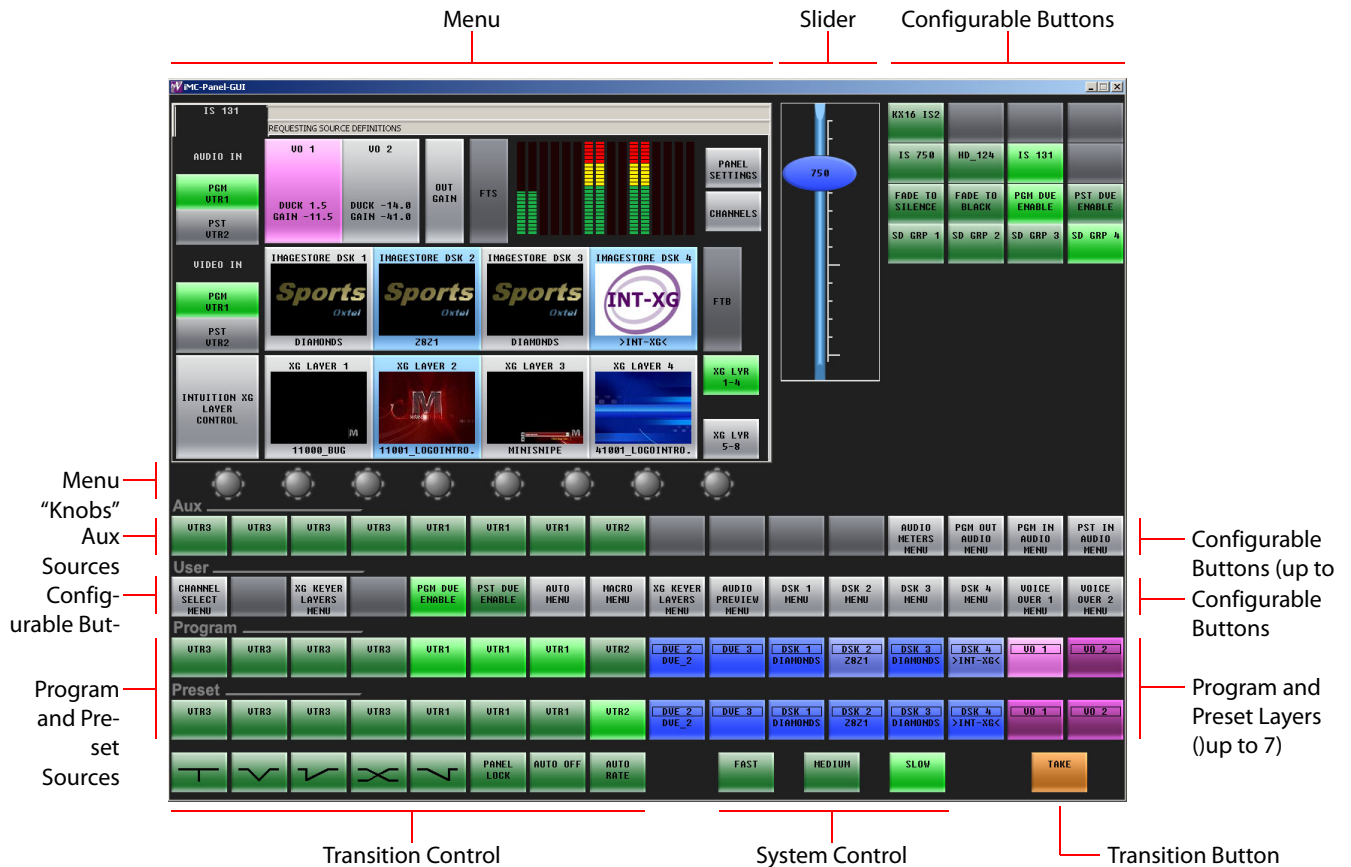

Fig. 3-8: Sections of the iMC-Panel-GUI (Shown Controlling an Imagestore 750)

▲ The PC on which the GUI runs must be set up to operate on the master control network.

## GUI Buttons

The buttons are moderately large and appear in several colors (grey, green, amber, red, blue, violet, white, and aqua) and 3 brightness levels: off, low-tally, and high-tally. They are dynamically re-legendable, displaying 3 lines of text, 8 characters each. (The text might be blank.)

The buttons allow you to choose sources, options, video effects, audio functions, transition effects, and other functions.

Some buttons are *toggles*. Pressing a deselected toggle button will cause it to become selected. Pressing a selected toggle button will make it deselected.

Some groups of buttons operate as a mutually exclusive set. Pressing a deselected button will cause it to become selected and all other buttons in the set to become deselected. There are two types of mutually exclusive buttons:

- 1 Pressing a selected button makes it deselected. (All other buttons in the set remain deselected.)
- 2 Pressing a selected button leaves the button selected.

The GUI also has a system of menu buttons. It is through the menu that you can adjust operating parameters such as audio levels and keyer settings.

This GUI's "Transition" button is at the lower right and it is usually orange. It is red during a pre-roll transition.

## Knobs and Slider

The GUI has knob "proxies" and a slider with which operators may change parameter values. The menu is associated with 8 knob proxies. The audio section has two knob proxies. The knob proxies do nothing by themselves. However, when you click a knob proxy, the slider appears. The slider is generally blue in color and allows coarse adjustments of a selected parameter.

An operator can perform fine adjustments of any parameter using the keypad buttons associated with a menu parameter.

## Functional Sections of the GUI

Following are brief descriptions of each section. Refer to Figure 3-7 on page 46.

### 1 Configurable buttons

The configurable button section includes 16 buttons with assignable legends. The content of the configurable button section differs when the panel is controlling an MCE or MCPM or an Imagestore 750.

For an MCE or MCPM, the configurable buttons may be programmed to perform functions such as channel selection, GPI triggers, or salvos. Some of these buttons can function as status indicators.

For an Imagestore 750, the configurable buttons may be programmed to perform functions such as channel selection, GPI macros, or menu selection. Some of these buttons can function as status indicators.

### 2 Menu

The content of the menu differs when the panel is controlling an MCE or MCPM or an Imagestore 750.

For an MCE or MCPM, you can control functions such as keyer settings, squeezeback settings and audio channels.

For an Imagestore 750, you can control functions such as downstream keyer (DSK) settings, DVE settings and audio channels.

Associated with the touchscreen are 8 knob "proxies" for adjustment of parameters.

### 3 Program and preset buttons

The iMC-Panel-GUI has 16 program buttons and 16 preset buttons. The functions of the buttons differ when the panel is controlling an MCE or MCPM or an Imagestore 750.

*For MCEs and MCPMs:*

The 16 *program* buttons includes *up to* 16 main source buttons (at the left) and *up to* 16 "layer" buttons (at the right). The layer buttons can be configured as DVEs, DSKs, Voice-overs, or XG keyer layers.

Whatever main source, DVEs, DSKs, Voice-overs, or XG keyer layers are selected on the program bus form the *program* output of the MCPM that is currently controlled by the iMC-Panel-GUI.

The *preset* buttons allows you to set up the state of the program output that will exist after the next transition.

The preset bus, program bus, and preview bus all have the same button functions.

(See [Bank Select](#) on page 144.)

*For Imagestore 750s:*

The 16 buttons of the program bus includes *up to* 16 main source buttons (at the left) and *up to* 10 “layer” buttons (at the right). The layer buttons can include 4 DVEs, 2 voice-overs, and 4 DSKs (downstream keyers).

Whatever main source, DVE, voice-overs, or DSKs are selected on the program bus form the *program* output of the Imagestore 750 that is currently controlled by the iMC-Panel-GUI.

The *preset* bus allows you to set up the state of the program output that will exist after the next transition.

The preset row and program row both have the same button functions. Note that the preset buttons correspond the Imagestore's *preview* output.

(See also the [Group Select](#) button on page 144.)

#### 4 Preview/user buttons

The iMC-Panel-GUI has 16 preview/user buttons. The functions of the buttons differ when the panel is controlling an MCE or MCPM or an Imagestore 750.

*For MCPMs:*

The preview/user buttons are disabled.

*For MCEs:*

The preview/user buttons are labeled “Preview” and allow a master control operator to preview (experiment with) main sources and video effects without interfering with on-air programming or with automation.

The preview/user buttons are the same as the program and preset buttons.

*For Imagestore 750s:*

The preview/user buttons are labeled “User” and provide customer-definable function buttons, among which are “menu” buttons. See [Preview/User Row](#) on page 176.

#### 5 Aux buttons

The iMC-Panel-GUI has 16 aux buttons. The functions of the buttons differ when the panel is controlling an MCE or MCPM or an Imagestore 750.

This button row contains *aux* and *aux delegate* buttons when the panel is controlling an MCE and contains *aux* and customer-definable function buttons when the panel is controlling an Imagestore 750. The button row is disabled when the panel is controlling an MCPM.

For MCEs, the aux buttons consist of the same main sources that appear on the preset, program, and preview buses plus up to 6 “aux delegate” buttons. The different delegate buttons determine the function of the aux bus. The aux bus might or might not be related to the aux outputs of an MCE, depending on configuration. See [Aux Delegates](#) on page 125.

For Imagestore 750s, the aux buttons consist of the same main sources that appear on the preset and program, buses plus up to 6 customer-definable function buttons, among which are “menu” buttons. See [Aux Row](#) on page 175. (Menu buttons turn menus on and off.)

#### 6 Transition control buttons

The 8 buttons in this section are, by default, transition buttons, but they are also configurable.

The functions of these buttons differ when the panel is controlling an MCE or MCPM or an Imagestore 750. See [Bottom Row Layout](#) (page 110, for MCEs and MCPMs) and [Bottom Row Layout](#) (page 164, for Imagestore 750s).

#### 7 System control buttons.

There are 3 buttons in the system control section of the iMC-Panel-GUI. Their functions differ when the panel is controlling an MCE or MCPM or an Imagestore 750. See [Bottom Row Layout](#) (page 110, for MCEs and MCPMs) and [Bottom Row Layout](#) (page 164, for Imagestore 750s).

For an MCE or MCPM, they are 'Panel Lock', 'Auto Off', and 'Fade to Black' by default. Each of these buttons can be configured to have another function, however, or no function at all.

#### 8 Transition button.

When the panel is controlling an MCE or MCPM, the transition button displays the transition type (as a graphic) and the transition rate (in text). It is almost always bright orange, but red during pre-roll transitions.

When the panel is controlling an Imagestore 750, the Transition shows the word 'Take'.

Pressing the transition button initiates a transition in the MCE, MCPM, or Imagestore 750, according to the GUI setup. Operators can change the transition rate and type using the touchscreen menu.

## Other Features

The aux buttons and preview/user buttons are disabled when the panel is controlling an MCPM.

When the panel is controlling an Imagestore 750, the preview buttons are customer-definable buttons. The aux buttons include customer-definable buttons.

## CECP Summary

The CECP is a configurable master control panel, 19.7" wide × 6.96" high × 20.21" deep. Rear connectors extend the depth 0.67". The CECP requires at least 2– 3" clearance at the rear for cables. The CECP sits on a console or desktop.

The CECP M1 (not shown) is a variant of the CECP. It has no joystick and no preview bus. It has two metering inputs at the rear, whereas the CECP has only one.



Figure 3-1 shows the location of the CECP's touchscreen, function buttons, and controls.

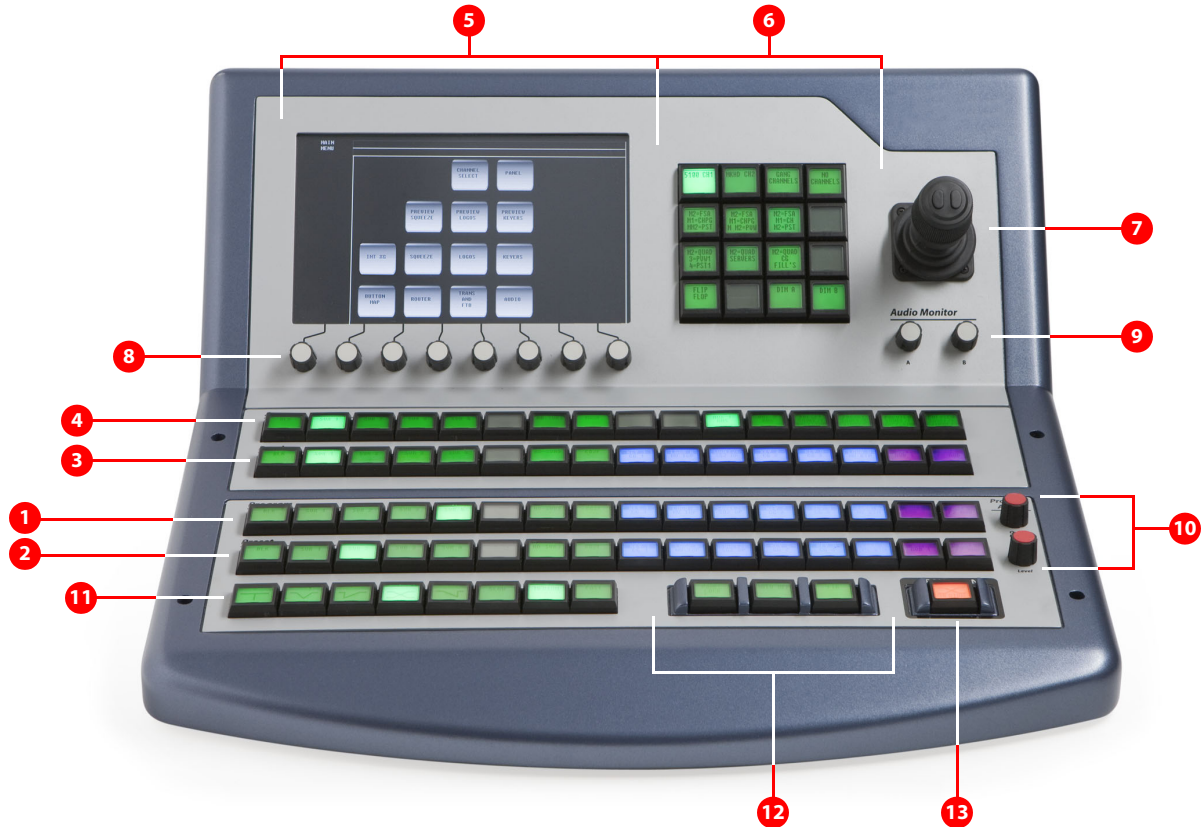

Fig. 3-9: Sections of the CECP

### Sections of the CECP

|    |                                   |    |  |    |  |
|----|-----------------------------------|----|--|----|--|
| 1  | <a href="#">Program buttons</a>   | 2  | <a href="#">Preset buttons</a>             | 3  | <a href="#">Preview buttons</a>        |
| 4  | <a href="#">Aux buttons</a>       | 5  | <a href="#">LCD touchscreen</a>            | 6  | <a href="#">Configurable buttons</a>   |
| 7  | <a href="#">Joystick</a>          | 8  | <a href="#">Touchscreen knobs</a>          | 9  | <a href="#">Audio monitor knobs</a>    |
| 10 | <a href="#">Audio level knobs</a> | 11 | <a href="#">Transition control buttons</a> | 12 | <a href="#">System control buttons</a> |
| 13 | <a href="#">Transition button</a> |    |  |    |  |

Following are brief descriptions of each section:

#### 1 Program buttons

The 16 buttons of the program bus include *up to* 16 main source buttons (at the left) and *up to* 12 “layer” buttons (at the right). The layer buttons can be configured as additional main sources, video effects, audio overs, or XG keyer layers.

Whatever main source, video effects, audio overs, and XG keyer layers are selected on the program bus form the *program* output of the MCPM that is currently controlled by the CECP. (See [Bank Select](#) on page 144.)

#### 2 Preset buttons

The preset bus allows you to set up the state of the program output that will exist after the next transition.

The preset bus has the same button definitions as the program bus.

#### 3 Preview buttons

The preview bus allows a master control operator to experiment with main sources and video effects without interfering with on-air programming or with automation. The preview bus has the same button definitions as the program and preset buses.

▲ The preview bus is enabled (active) only when the CECP controls an MCE.

▲ The CECP M1 has no preview bus.

#### 4 Aux buttons

The aux (auxiliary) bus consists of the same main sources that appear on the preset, program, and preview buses plus up to 6 “aux delegate” buttons. The different delegate buttons determine the function of the aux bus. The aux bus might or might not be related to the aux outputs of an MCE, depending on configuration. See [Aux Delegates](#) on page 125.

▲ The aux bus is enabled (active) only when the CECP controls an MCE.

#### 5 LCD touchscreen

Using the color LCD touchscreen, you can control system functions such as keyer settings, squeezeback settings and audio channels. Associated with the touchscreen are 4 rotary knobs for scrolling and for adjustment of parameters.

#### 6 Configurable buttons

The configurable button section includes 16 buttons with assignable legends, each of which may be programmed to perform functions such as channel selection, GPI triggers, or salvos. Some of these buttons can function as status indicators.

#### 7 Joystick

The joystick allows fine visual adjustment of squeezeback images for the MCPM-SDHD and MCEs. It also allows the adjustment of other video effects and allows operators to scroll data displays, such as a panel log report.

The joystick has 2 buttons and a knurled cylinder that the operator turns to control a third axis.

▲ The CECP M1 has no joystick.

#### 8 Touchscreen knobs

The 8 knobs under the touchscreen allow the operator to adjust menu parameters. Not all knobs are active all the time. When a knob is active, the touchscreen shows a colored indicator near the knob.

#### 9 Audio monitor knobs

An MCPM has 2 audio monitor buses, A and B. The 2 monitor knobs allow you to increase or decrease the audio monitor levels.

#### 10 Audio level knobs

There are 2 rotary knobs for adjusting the audio output level of the source selected on the program bus, and the ratio of the audio over to the main source audio for the program bus. (Operators use the menus to change the audio levels of the preset bus.)

### 11 Transition control buttons

The 8 buttons in this section are, by default, transition buttons, but they are also configurable.

### 12 System control buttons

There are 3 buttons in the system control section of the CECF. They are 'Panel Lock', 'Auto Off', and 'Fade to Black' by default. Each of these buttons can be configured to have another function, however, or no function at all.

- ▲ The configuration editor treats the 8 transition control buttons and 3 system control buttons as a single group—the "Bottom Row Buttons."

### 13 Transition button

The transition button displays the transition type (as a graphic) and the transition rate (in text). It is always bright orange.

Pressing the transition button initiates a transition in the MCPM according to the CECF setup. Operators can change the transition rate and type using the touchscreen menu.

## CECF Buttons

Buttons appear in several colors and 3 brightness levels: off, low-tally, and high-tally.

Buttons allow the operator to choose sources and video effects and to make menu selections. Some buttons display status. Pressing a button usually selects something. However, nothing happens when the operator pushes a button that is disabled or off and nothing happens when the operator pushes a button that merely displays status.

The buttons on the panel display the following colors:

|            |           |             |             |       |            |
|------------|-----------|-------------|-------------|-------|------------|
| Low Green  | Low Blue  | Low Violet  | Low Orange  | Gray  | High Red   |
| High Green | High Blue | High Violet | High Orange | White | High Amber |

In addition to these colors, a button can be dark (that is, off, or having no color). High-tally red and high-tally amber usually indicate warnings.

The following color scheme usually applies. Exceptions will be noted.

- Non-selected state: low tally—green, blue, violet, or orange.
- Selected state: high tally—green, blue, violet, orange, white, or red.  
Source buttons on the program bus can be configured to be high-tally green, white, or red when selected. (This does not affect the other buses.)
- Status: green, white, amber, red. (Status buttons generally do nothing when pressed—unless they also have a control function.)

Some buttons are *toggles*. Pressing a deselected toggle button will cause it to become selected. Pressing a selected toggle button will make it deselected.

Some groups of buttons operate as a mutually exclusive set. Pressing a deselected button will cause it to become selected and all other buttons in the set to become deselected. There are two types of mutually exclusive buttons:

- 1 Pressing a selected button makes it deselected. (All other buttons in the set remain deselected.)
- 2 Pressing a selected button has no effect: the button remains selected.

## CECP Knobs

Turning a knob clockwise increases the associated value until the maximum value is reached. Turning the knob counter-clockwise decreases the associated value until the minimum value is reached. Turning the knob beyond its value limits has no effect.

An indicator on the touchscreen illuminates just above any of the 8 touchscreen knobs when it is enabled.

## CECP Touchscreen

The touchscreen and its 8 associated knobs provides a menu system in which you can do the following:

- Select a channel (i.e., MCPM or MCE).
- Select a main source or an over source.
- Choose a router source.
- Select a video effect and alter its settings.
- Manipulate audio.
- Change transition rates.
- Perform panel maintenance and updates.
- View status and error messages.
- View “live levels” (MCEs only).

The touchscreen provide scroll bars for list selection.

## CECP Connectors

At the rear of the CECP are 2 power connectors, one Ethernet connector, a USB port, a fan, an aux connector, a GPI/alarm connector, and an audio metering input:



Fig. 3-10: CECP (rear view)

The USB port and the aux port are *reserved for future development*.

The CECP M1 has two metering inputs.

## Power

There are 2 AC connectors, PS1 and PS2, for redundancy. You need not use both if you are not concerned with redundancy.

## Ethernet

The CECP has one RJ-45 Ethernet port. The CECP connects to the Ethernet switch of the master control network.

It is on this network that the CECP communicates with MCPMs and with the configuration software. You (or your system administrator) must provide a unique IP address for the CECP. Use the Panel ID menu under the Panel Menu to set the IP address and IP subnet mask. The default IP address is 192.168.7.100 and the subnet mask must always be 255.255.255.0.

## GPI/Alarm

The CECP has a DB25 connector that supports GPI inputs, GPI outputs, and alarms:

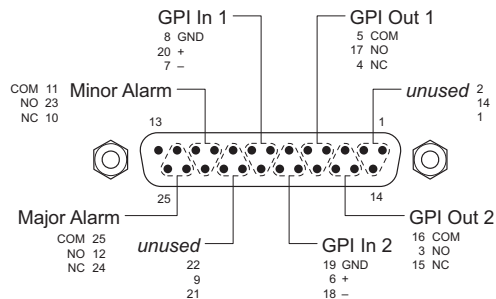

Refer to the GPI section in the *CECP Operator's Guide* for connection information. Also see [Panel GPI](#) on page 193.

## Audio Metering Input

The audio metering output of an MCE is a suitable source for this input.

In general, the panel's audio metering inputs are **not** related to the panel's audio metering controls. However, when the metering inputs are connected to the MCE under control, the metering controls **are** related.

## CECP

The 'SD/HD Input' connector (BNC) is the panel's audio metering input. This input drives the panel's "live levels" display. As the label implies, the input can be either SD or HD video with up to 16 channels of audio embedded. The live levels display shows the audio levels of all 16 channels in real time.

## CECP M1

The 'Metering Input' connectors (BNC) are labeled 'A' and 'B'. These inputs drive the panel's "live levels" display. The inputs can be either SD or HD video with up to 16 channels of audio embedded. The live levels display shows the audio levels of all 16 channels in real time.

There is a button function available that switches between metering inputs A and B.

## FECF Summary

The FECF is a configurable master control panel, 28.25" wide × 6.96" high × 20.14" deep. It has only one mounting option: it sits on a console or desk top.

Arrayed on the panel are 140 color-coded LCD buttons, a touchscreen menu (LCD) with 8 associated control knobs, 2 white toggle buttons, 4 audio knobs (a.k.a. rotary encoders), and a joystick. Each LCD button shows 3 lines of text, 8 characters per line. The LCD buttons are either green, amber, red, blue, white, or violet, — off, low-tally, or high-tally. Red is generally used to indicate an error condition. The surface of the FECF is light gray and dark blue-gray.



Fig. 3-11: FECF (front view)

## Sections of the FECP

|   |  |    |  |
|---|--|----|--|
| 1 | <a href="#">Customer-programmable buttons</a>        | 7  | <a href="#">Aux buttons</a>                                  |
| 2 | <a href="#">Touchscreen menu</a>                     | 8  | <a href="#">Program, preset, and preview "layer" buttons</a> |
| 3 | <a href="#">Joystick</a>                             | 9  | <a href="#">Transition control buttons</a>                   |
| 4 | <a href="#">Audio monitor/meter control</a>          | 10 | <a href="#">System control buttons</a>                       |
| 5 | <a href="#">Program audio control</a>                | 11 | <a href="#">Transition button</a>                            |
| 6 | <a href="#">Program, preset, and preview sources</a> |    |  |

At the rear of the panel are 2 power connections, an Ethernet port, a USB port, an aux port, and a GPI/alarm connector (DB25), and an audio metering input.

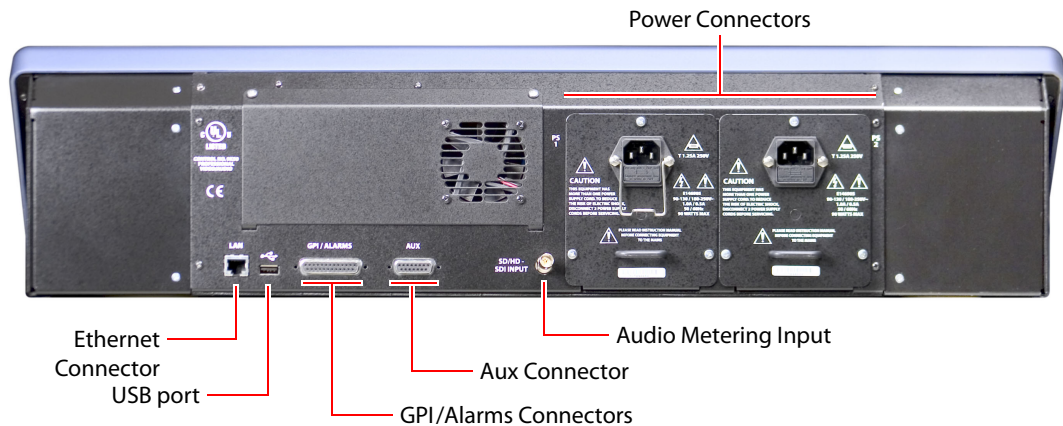

Fig. 3-12: FECP (rear)

## FECP Buttons

Panel buttons are large and appear in several colors (green, amber, red, blue, white, and violet) and 3 brightness levels: off, low-tally, and high-tally. They are dynamically re-legendable, displaying 3 lines of text, 8 characters per line. (The text might be blank.)

The buttons allow you to select channels, choose sources, options, video effects, and audio overs, and perform other functions. Some buttons can serve as status buttons.

The buttons on the panel display the following colors:

|            |           |             |             |       |            |
|------------|-----------|-------------|-------------|-------|------------|
| Low Green  | Low Blue  | Low Violet  | Low Orange  | Gray  | High Red   |
| High Green | High Blue | High Violet | High Orange | White | High Amber |

In addition to these 12 colors, a button can be dark (that is, off, or having no color). High-tally red and high-tally amber usually indicate warnings.

The following color scheme usually applies. Exceptions will be noted.

- Non-selected state: low tally—green, blue, violet, or orange.
- Selected state: high tally—green, blue, violet, orange, white, or red.  
Source buttons on the program bus can be configured to be high-tally green, white, or red when selected. (This does not affect the other buses.)
- Status: green, white, amber, red. (Status buttons generally do nothing when pressed—unless they also have a control function.)

Some buttons are *toggles*. Pressing a deselected toggle button will cause it to become selected. Pressing a selected toggle button will make it deselected.

Some groups of buttons operate as a mutually exclusive set. Pressing a deselected button will cause it to become selected and all other buttons in the set to become deselected. There are two types of mutually exclusive buttons:

- 1 Pressing a selected button makes it deselected. (All other buttons in the set remain deselected.)
- 2 Pressing a selected button leaves the button selected.

The FECP has a menu system built into its LCD touchscreen. It is through the menu that you can adjust operating parameters such as audio levels and keyer settings. If an MCPM configuration permits, the operator may also modify keyer settings.

The FECP's "Transition" button (orange) is large and obvious.

## FECP Knobs

Turning a knob clockwise increases the associated value until the maximum value is reached. Turning the knob counter-clockwise decreases the associated value until the minimum value is reached. After you reach either extremity, turning the knob has no effect.

## FECP Touchscreen

The touchscreen and its 8 associated knobs provides a menu system in which you can do the following:

- Select a channel (i.e., MCPM or MCE).
- Select a main source or an over source.
- Choose a router source.
- Select a video effect and alter its settings.
- Manipulate audio.
- Change transition rates.
- Perform panel maintenance and updates.
- View status and error messages.
- View "live levels" (MCEs only).

The touchscreen provide scroll bars for list selection.

## Functional Sections of the FECP

Following are brief descriptions of each section. Refer to Figure 3-3 on page 32.

### 1 Customer-programmable buttons

The customer-programmable section includes 16 function buttons, each of which may be programmed to perform functions such as channel selection, GPI triggers, or transition control.



## 2 Touchscreen menu

Using the color LCD touchscreen, you can access all secondary system functions such as key setups, squeezeback presets and audio settings. Associated with the touchscreen are 8 rotary knobs for selection and adjustment of parameters.

## 3 Joystick

The joystick allows fine visual adjustment of squeezeback images for the MCPM-SDHD and MCEs. It also allows the adjustment of other video effects and allows operators to scroll data displays, such as a panel log report.

The joystick has 2 buttons and a knurled cylinder that the operator turns to control a third axis.

## 4 Audio monitor/meter control

The audio monitoring section (of an MCPM or MCE) provides 2 independent audio monitoring buses and a bus for audio metering. Panel buttons include a choice of 4 sources — program audio, preset audio, preview audio (when it becomes available), aux audio, or “off-air” audio — and a dedicated “dim” button for each bus, and independent monitor level controls knobs. (There are no controls for the metering bus levels.)

The monitor/meter buttons are configurable within the scope of audio functions.

## 5 Program audio control

The audio level section includes 2 rotary knobs for adjusting the output level of the source selected on program, and the program over/main ratio.

## 6 Program, preset, and preview sources

The 24 buttons of the program bus includes *up to* 16 main source buttons (at the left) and *up to* 12 “layer” buttons (at the right). The layer buttons can be configured as video effects, audio overs, or XG keyer layers.

Whatever main source, video effects, audio overs, or XG keyer layers are selected on the program bus form the *program* output of the MCPM that is currently controlled by the FECP.

The preset bus allows you to set up the state of the program output that will exist after the next transition.

The preset bus, program bus, and preview bus all have the same button functions.

The preview bus allows a master control operator to experiment with main sources and video effects without interfering with on-air programming or with automation.

▲ The preview bus is enabled (active) only when the FECP controls an MCE.

## 7 Aux buttons

The aux (auxiliary) bus consists of the same main sources that appear on the preset, program, and preview buses plus up to 6 “aux delegate” buttons. The different delegate buttons determine the function of the aux bus. The aux bus might or might not be related to the aux outputs of an MCE, depending on configuration. See [Aux Delegates](#) on page 125.

▲ The aux bus is enabled (active) only when the FECP controls an MCE.

## 8 Program, preset, and preview “layer” buttons

The layer section is a part of the program/preset bus that allows you to combine video effects, audio overs, and XG keyer layers with your main source selections. Video effects include keyers, logos, and a squeezeback generator. (Some MCPMs do not support all effects. Only MCEs support XG keyer layers.)

- ▲ The preview bus is enabled (active) only when the FECP controls an MCE.

#### 9 Transition control buttons

The 12 transition control buttons include breakaway buttons, transition types, and transition rates, by default. (The actual rates are configured in the MCPM.) These buttons are configurable.

#### 10 System control buttons

The system control buttons include 3 buttons: 'Panel Lock', 'Automation Off', and master 'Fade to Black' by default. These buttons are configurable.

#### 11 Transition button

The transition button displays the transition type (as a graphic) and the transition rate (in text). It is always bright orange.

Pressing the transition button initiates a transition in the MCPM according to the FECP setup. Operators can change the transition rate and type using the touchscreen menu.

## FECP Connectors

At the rear of the FECP are 2 power connectors, one Ethernet connector, a USB port, a 'CP aux' connector, a GPI/alarm connector, and an audio metering input. (See Figure 3-12 on page 57.) The USB port and aux port are reserved for future development.

### Power

There are 2 AC connectors, PS1 and PS2, for redundancy. You need not use both if you are not concerned with redundancy.

### Ethernet

The FECP has one RJ-45 Ethernet port. The FECP connects to the Ethernet switch of the master control network.

It is on this network that the FECP communicates with MCPMs and with the configuration software. You (or your system administrator) must provide a unique IP address for the FECP. Use the Panel ID menu under the Panel Menu to set the IP address and IP subnet mask. The default IP address is 192.168.7.100 and the subnet mask must always be 255.255.255.0.

### GPI/Alarm

The FECP has a DB25 connector that supports GPI inputs, GPI outputs, and alarms:

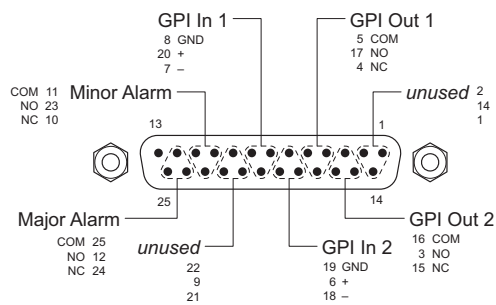

Refer to the GPI section in the *FECP Operator's Guide* for connection information. Also see [Panel GPI](#) on page 193.

### Audio Metering Input

The 'SD/HD Input' connector (BNC) is the panel's audio metering input. This input drives the panel's "live levels" display. As the label implies, the input can be either SD or HD video with up to 16 channels of audio embedded. The live levels display shows the audio levels of all 16 channels in real time.

The audio metering output of an MCE is a suitable source for this input.

In general, the panel's audio metering inputs are *not* related to the panel's audio metering controls. However, when the metering inputs are connected to the MCE under control, the metering controls *are* related.

## CECP GUI Summary

The CECP GUI is a software control panel that runs on a PC connected to the master control network. It emulates the functions of the CECP.

Its menu section emulates the touchscreen menu of the CECP. The GUI can be operated either with a mouse on any PC or by finger pressure on a touchscreen PC.

- ▲ The GUI window is 1280×966 pixels and requires a monitor at least that size to function. (Although the GUI window can be resized, doing so prevents access to parts of the GUI.)

Arrayed on this panel are 95 color-coded buttons and a menu with 8 associated menu "knobs." The knobs are graphical of course and emulate the 8 menu knobs of the CECP.

Each button has 3 lines of text, 8 characters per line. Active buttons, like those of the CECP, are either green, red, amber, white, blue, or violet and off, low-tally, or high-tally. Buttons that are unused are just grey. Red generally indicates an error condition. Buttons that are defined, but disabled momentarily, show dimmed text.

High-tally buttons are brighter or lighter than buttons that are low-tally.

Figure 3-18 identifies the sections of the CECP GUI:

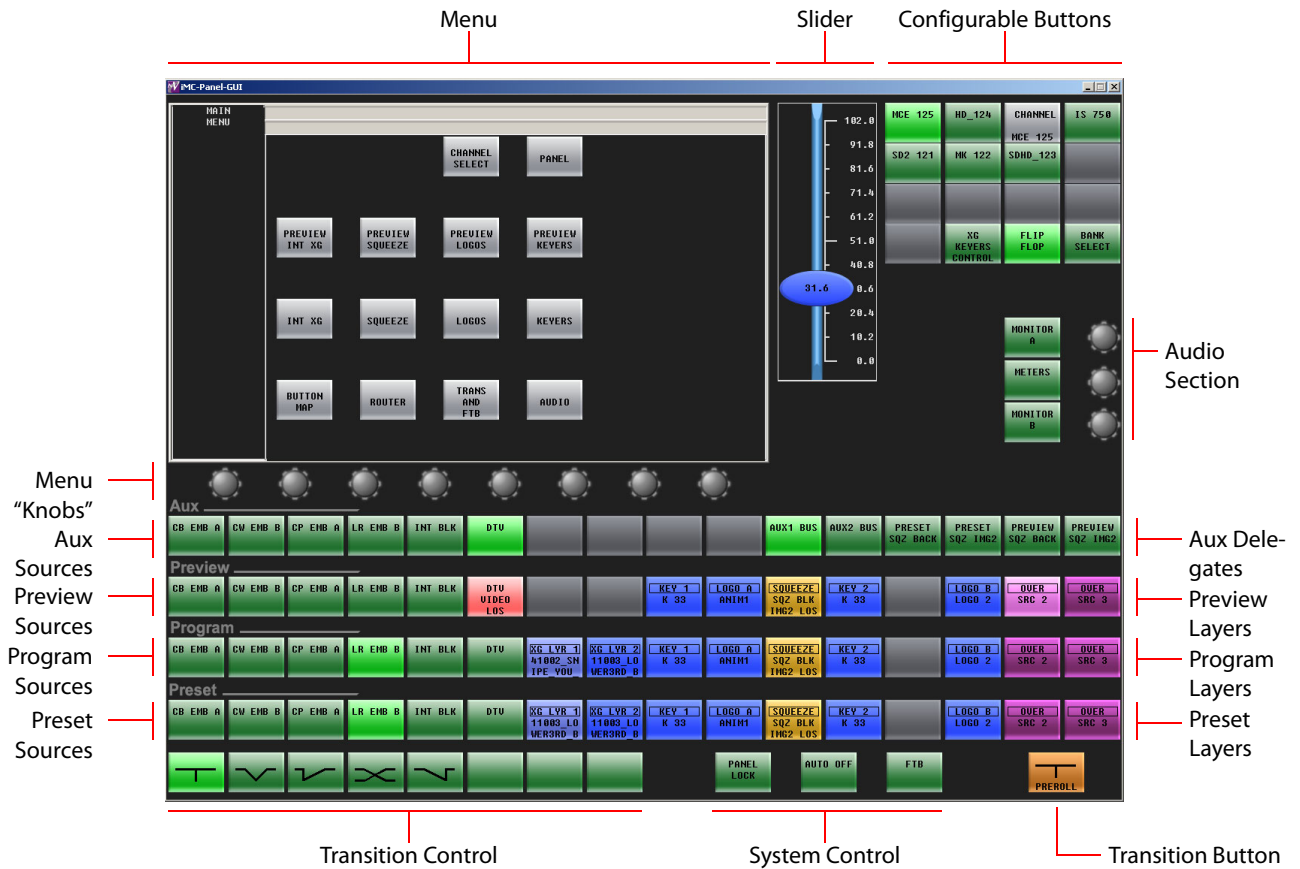

Fig. 3-13: CECP GUI

## GUI Buttons

The buttons are moderately large and appear in several colors (grey, green, amber, red, blue, violet, and white) and 3 brightness levels: off, low-tally, and high-tally. They are dynamically re-legendable, displaying 3 lines of text, 8 characters each. (The text might be blank.)

The buttons allow you to choose sources, options, video effects, audio functions, transition effects, and other functions.

In addition to these colors, a button can be dark (that is, off, or having no color). High-tally red and high-tally amber usually indicate warnings.

The following color scheme usually applies. Exceptions will be noted.

- Non-selected state: low tally — green, blue, violet, or orange.
- Selected state: high tally — green, blue, violet, orange, white, or red.

Source buttons on the program bus can be configured to be high-tally green, white, or red when selected. (This does not affect the other buses.)

- Status: green, white, amber, red. (Status buttons generally do nothing when pressed — unless they also have a control function.)

Some buttons are *toggles*. Pressing a deselected toggle button will cause it to become selected. Pressing a selected toggle button will make it deselected.

Some groups of buttons operate as a mutually exclusive set. Pressing a deselected button will cause it to become selected and all other buttons in the set to become deselected. There are two types of mutually exclusive buttons:

- 1 Pressing a selected button makes it deselected. (All other buttons in the set remain deselected.)
- 2 Pressing a selected button leaves the button selected.

The GUI also has a system of menu buttons. It is through the menu that you can adjust operating parameters such as audio levels and keyer settings. If an MCPM configuration permits, the operator may not only select keyer settings, but modify them.

This GUI's "Transition" button is orange and at the lower right.

## Knobs and Slider

The GUI has knob "proxies" and a slider with which operators may change parameter values. The menu is associated with 8 knob proxies. The audio section has two knob proxies. The knob proxies do nothing by themselves. However, when you click a knob proxy, the slider appears. The slider is generally blue in color and allows coarse adjustments of a selected parameter.

An operator can perform fine adjustments of any parameter using the keypad buttons associated with a menu parameter.

## Functional Sections of the GUI

Following are brief descriptions of each section. Refer to Figure 3-7 on page 46.

### 1 Configurable buttons

At the top right, the configurable button section includes 16 function buttons, each of which may be programmed to perform functions such as channel selection, GPI triggers, or transition control.

### 2 Menu

Using the menu, an operator can access all secondary system functions such as keyer settings, squeezeback presets and audio settings. Associated with the menu are 8 menu knobs for selection and adjustment of parameters.

### 3 Audio section

The audio monitoring section (of an MCPM) provides 2 independent audio monitoring buses and a bus for audio metering. The GUI's audio menus allow the choice 4 sources—program audio, preset audio, preview audio (when it becomes available), aux audio, or "off-air" audio—and a dedicated "dim" button for each bus, and independent monitor level controls. The audio menus also allow control of the audio output levels. You can adjust any level with the arrow buttons next to the menu.

The GUI's *audio section* (middle right) provides shortcuts for accessing the audio menus. Associated with the two monitor buttons are two knob proxies with which operators may directly adjust monitor levels.

### 4 Program bus

The 16 buttons of the program bus include *up to* 16 main source buttons and *up to* 12 "layer" buttons. The layer buttons can be configured as additional main sources, video effects, audio overs, or XG keyer layers.

▲ Some MCPMs do not support all video effects. Only MCEs support XG keyer layers. Whatever main source, video effects, audio overs, and XG keyer layers are selected on the program bus form the *program* output of the MCPM that is currently controlled by the GUI. (See [Bank Select](#) on page 144.)

#### 5 Preset bus

The preset bus allows you to set up the state of the program output that will exist after the next transition.

The preset bus has the same button definitions as the program bus.

#### 6 Preview bus

The preview bus allows a master control operator to experiment with main sources and video effects without interfering with on-air programming or with automation. The preview bus has the same button definitions as the program and preset buses.

▲ The preview bus is enabled (active) only when the GUI controls an MCE.

#### 7 Aux bus

The aux (auxiliary) bus consists of the same main sources that appear on the preset, program, and preview buses plus up to 6 “aux delegate” buttons. The different delegate buttons determine the function of the aux bus. The aux bus might or might not be related to the aux outputs of an MCE, depending on configuration. See [Aux Delegates](#) on page 125.

▲ The aux bus is enabled (active) only when the GUI controls an MCE.

#### 8 Transition control buttons

The transition control buttons are all configurable. By default, they include 5 transition type (cut, V-fade, cross-fade, cut-fade, and fade-cut) buttons and 3 transition rate buttons. (The actual rates are configured in the current MCPM.)

#### 9 System control buttons.

By default, the system control buttons include 3 buttons: ‘Panel Lock’, ‘Automation Off’, and master ‘Fade to Black. You can redefine them.

#### 10 Transition button.

Operators press the transition button to start a transition of preset content to the program bus. A transition can involve “pre-roll” or machine control. The large orange transition button at the lower right displays the current transition type and transition rate. It turns red when a machine control transition is pending.

## Other Features

The aux bus and preview bus are for use with MCEs.

## CFCP Summary

The CFCP is a console-mounted or rack-mounted master control panel. It can simply rest on a desktop or flat surface, or it can be recessed into the desktop. It is 19” wide and about 15” deep. The entire top panel swings open for service. (You can access certain DIP switches and the rack-mounting rails.)

Arrayed on the front of the panel are 48 color-coded LCD buttons, a touchscreen LCD with 4 associated control knobs, 27 white toggle buttons, and 5 audio knobs (a.k.a. rotary encoders). Each LCD button shows 2 lines of text, 4 characters per line. The LCD buttons are either “green,” “amber,” or “red,” — off, low-tally, or high-tally. Red generally indicates an error condition.

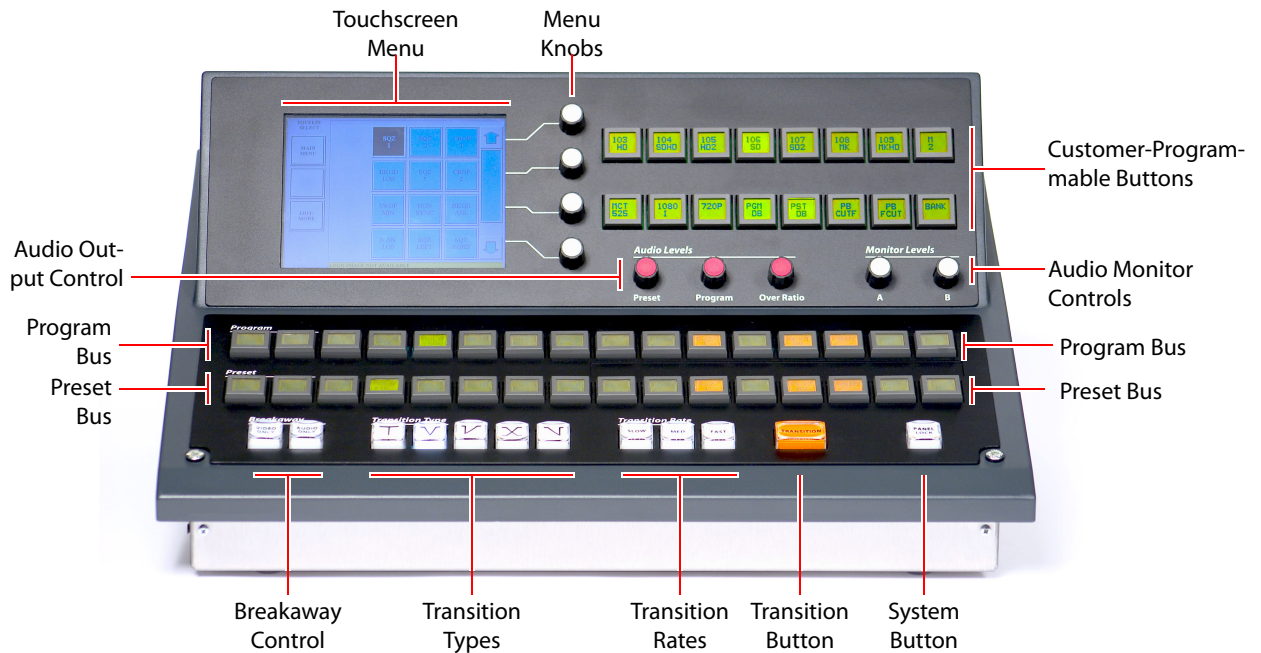

Fig. 3-14: CFCP (front view)

The CFCP has 16 program and preset button pairs. Both the program bus and the preset bus are configurable. The rightmost 8 button pairs can be configured as main sources, video effects, or audio overs. All 16 button pairs could be main sources. Up to 6 button pairs can be video effects. Up to 2 buttons can be audio overs.

With a “bank select” button in the customer-programmable button section, the operator can switch between two banks of main sources. The button mnemonics change when the sources are switched. The bank selection button itself turns green or amber depending on which bank is selected.

The CFCP has 2 audio monitor knobs and 3 audio level knobs.

The CFCP has 1 system control button; it is configurable.

The surface of the CFCP is charcoal gray and black.

At the rear of the panel are 2 power connections, 2 Ethernet ports, a 'CP Aux' connector (DB15) used for the optional TLA, and a GPI/alarm connector (DB25).

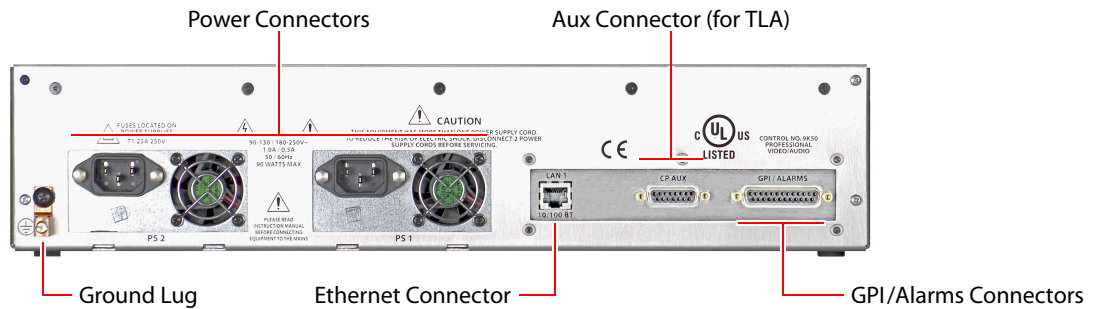

Fig. 3-15: CFCP (rear panel)

## CFCP Buttons

LCD buttons are large and appear in 3 colors (green, amber, and red) and 3 brightness levels: off, low-tally, and high-tally. They are dynamically re-legendable, displaying 2 lines of text, 4 characters each. (The text might be blank.)

LCD buttons allow you to choose sources, options, video effects, and audio overs.

In addition to the LCD buttons, there several white (low- and high-tally) *toggle* buttons that, for example, select a transition type, enable breakaway, or perhaps, fade program output to matte and silence.

Pressing a deselected toggle button will cause it to become selected. Pressing a selected toggle button will make it deselected.

Some groups of buttons operate as a mutually exclusive set. Pressing a deselected button will cause it to become selected and all other buttons in the set to become deselected. There are two types of mutually exclusive buttons:

- 1 Pressing a selected button makes it deselected. (All other buttons in the set remain deselected.)
- 2 Pressing a selected button leaves the button selected.

The CFCP has a menu system built into its LCD touchscreen. It is through the menu that you can adjust operating parameters such as audio levels and keyer settings. If an MCPM configuration permits, the operator may not only select keyer settings, but modify them.

The CFCP's "Transition" button (orange) is large and obvious.

## CFCP Knobs

Turning a knob clockwise increases the associated value until the maximum value is reached. Turning the knob counter-clockwise decreases the associated value until the minimum value is reached. After you reach either extremity, turning the knob has no effect.

## Functional Sections of the CFCP

Following are brief descriptions of each section. Refer to Figure 3-14 on page 65.



## 1 Customer-programmable buttons

The customer-programmable section includes 16 function buttons. Each may be programmed to perform functions such as channel selection, GPIO, or transition control.

Because the CFCP has fewer physical buttons than the FFCP, it has these extra functions:

- Bank select. Choose bank 1 or bank 2 of the main sources.
- Dim A, Dim B. Mute the output level of monitor A or B.

## 2 Touchscreen menu

Using the color LCD touchscreen, you can access all secondary system functions such as key setups, squeezeback presets and audio settings. Associated with the touchscreen are 4 rotary knobs for selection and adjustment of parameters.

## 3 Audio monitor controls

The audio monitoring section (of an MCPM or MCE) provides 2 independent audio monitoring buses and a bus for audio metering. The panel has two monitor level knobs.

There are no dedicated panel buttons for these buses. An operator uses the menu to choose which source to monitor or meter: program audio, preset audio, aux, or "off-air" audio. A "Dim" function for monitor A and for monitor B can be configured as customer-programmable buttons.

## 4 Audio output control

The audio output section includes 3 rotary knobs for adjusting the output level of the source selected on preset or program, and the over/main ratio for preset or program.

## 5 Program/preset buttons

The program bus corresponds to what is on program output at present. The preset bus allows you to premix a source with video effects and audio overs in preparation for a transition to the program bus.

The program and preset "buses" include two rows of 16 buttons used for audio and video source selections, video effects, and audio overs. Each button is dynamically "re-legendable." The purpose of each of the 16 button pairs is configurable.

The leftmost 8 buttons are main source buttons. Using a bank select button and 2 banks, A and B, you can have up to 16 "virtual" buttons.

The rightmost 8 buttons can be configured as main sources, video effects, or audio overs. Main sources, video effects (and audio overs) can be assigned to the buttons in any order and in almost any combination. (Video effects cannot be duplicated.)

- ▲ It is the MCPM or MCE that performs the effects and overs, and the order in which it applies them does not change.

Up to 6 buttons are for video effects: 3 keyers, 2 logos, and a squeezeback function. The panel can have up to 2 audio "over" buttons.

- ▲ Some MCPMs do not support all video effects.

## 6 Breakaway buttons.

Two buttons at the left allow operators to perform video breakaway or audio breakaway.

## 7 Transition buttons

The transition buttons include 2 groups: transition type, transition rate, and a larger orange button that initiates transitions. There are 5 transition types: cut, V-fade, cross-fade, cut-fade,

and fade-cut. There are 3 transition rates: slow, medium, and fast. (The actual rates are configured in the current MCPM or MCE.)

#### 8 System control button.

The system control button is 'Panel Lock' by default, but it can be configured for some other function.

## CFCP Connectors

At the rear of the CFCP are 2 power connectors, one Ethernet connector, a 'CP aux' connector, a GPI/alarm connector, and a ground lug. (See Figure 3-15 on page 66.)

### Power

There are 2 AC connectors, PS1 and PS2, for the sake of redundancy. You need not use both if you are not concerned with redundancy. The internal power supply modules include fans.

### Ethernet

The CFCP has one RJ-45 Ethernet port. The CFCP connects to the Ethernet switch on the master control network.

It is on this network that the CFCP communicates with MCPMs and with the configuration software. You (or your system administrator) must provide a unique IP address for the CFCP.

Without the IP address, the CFCP cannot communicate with either the MCPMs or the configuration software. Use the Panel ID menu under the Panel Menu to set the IP address and IP subnet mask.

The default IP address is 192.168.7.100 and the subnet mask must always be 255.255.255.0.

### GPI/Alarm

The CFCP has a DB25 connector that supports GPI inputs, GPI outputs, and alarms:

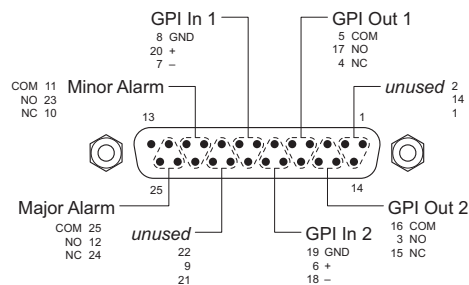

Refer to the GPI section in the *CFCP Operator's Guide* for connection information. Also see [Panel GPI](#) on page 193.

### CP Aux Connector

The CFCP has a DB15 connector to which you connect the optional TLA.

### Ground Lug

Connect the ground lug, using 8–14 AWG copper wire to earth ground. (This is a safety measure and is not required for the control panel to operate.)

## FFCP Summary

The FFCP is a console-mounted master control panel. It can simply rest on a desktop or flat surface, or it can be recessed into the desktop. It is 29" wide and about 15" deep.

▲ The FFCP does **not** support Imagestore 750 transition processors.

The entire top panel swings open for service. (You can access certain DIP switches.)

Arrayed on the front of the panel are 48 color-coded LCD buttons, a touchscreen menu (LCD) with 4 associated control knobs, 27 white toggle buttons, and 5 audio knobs (a.k.a. rotary encoders). Each LCD button shows 2 lines of text, 4 characters per line. The LCD buttons are either "green," "amber," or "red," —off, low-tally, or high-tally. Red generally indicates an error condition.

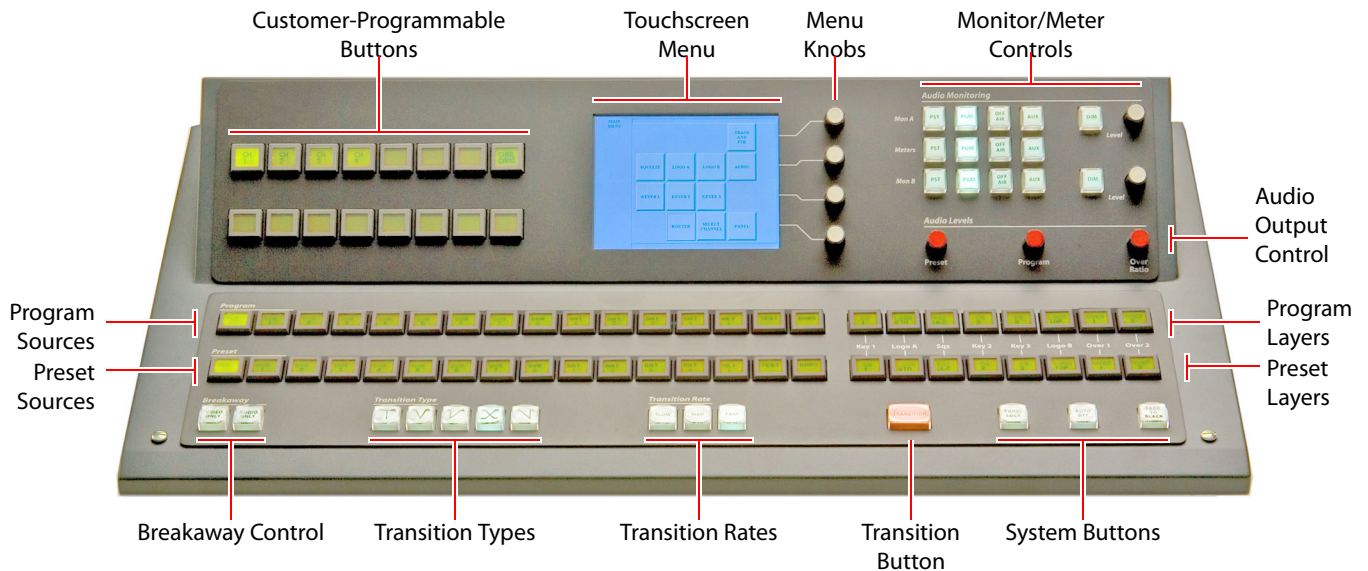

Fig. 3-16: FFCP (front view)

The surface of the FFCP is charcoal gray and black.

At the rear of the panel are 2 power connections, 2 Ethernet ports, a 'CP Aux' connector (DB15) used for the optional TLA, and a GPI/alarm connector (DB25).

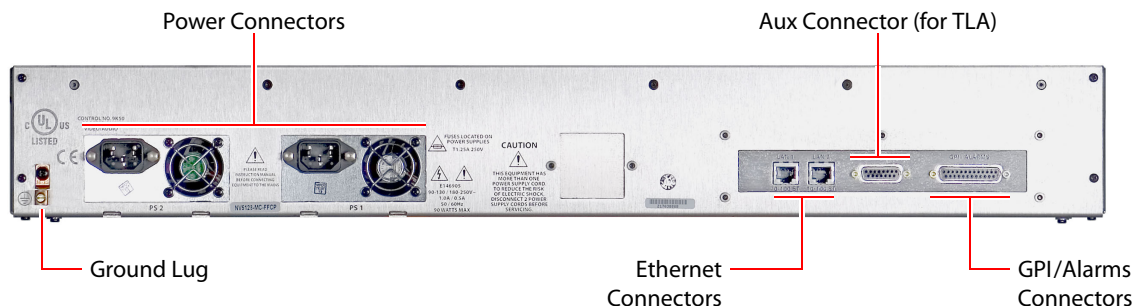

Fig. 3-17: FFCP (rear panel)

(The Ethernet port marked LAN2 is not used.)

## FFCP Buttons

LCD buttons are large and appear in 3 colors (green, amber, and red) and 3 brightness levels: off, low-tally, and high-tally. They are dynamically re-legendable, displaying 2 lines of text, 4 characters each. (The text might be blank.)

LCD buttons allow you to choose sources, options, video effects, and audio overs.

In addition to the LCD buttons, there many white (low- and high-tally) *toggle* buttons that, for example, select a transition type, mute an audio monitor output, or fade program output to matte/silence.

Pressing a deselected *toggle* button will cause it to become selected. Pressing a selected toggle button will make it deselected.

Some groups of buttons operate as a mutually exclusive set. Pressing a deselected button will cause it to become selected and all other buttons in the set to become deselected. There are two types of mutually exclusive buttons:

- 1 Pressing a selected button makes it deselected. (All other buttons in the set remain deselected.)
- 2 Pressing a selected button leaves the button selected.

The FFCP has a menu system built into its LCD touchscreen. It is through the menu that you can adjust operating parameters such as audio levels and keyer settings. If an MCPM configuration permits, the operator may not only select keyer settings, but modify them.

The FFCP's "Transition" button (orange) is large and obvious.

## FFCP Knobs

Turning a knob clockwise increases the associated value until the maximum value is reached. Turning the knob counter-clockwise decreases the associated value until the minimum value is reached. After you reach either extremity, turning the knob has no effect.

## Functional Sections of the FFCP

Following are brief descriptions of each section. Refer to Figure 3-16.

### 1 Customer-programmable buttons

The customer-programmable section includes 16 function buttons, each of which may be programmed to perform functions such as channel selection, GPI triggers, or transition control.

### 2 Touchscreen menu

Using the color LCD touchscreen, you can access all secondary system functions such as key setups, squeezeback presets and audio settings. Associated with the touchscreen are 4 rotary knobs for selection and adjustment of parameters.

### 3 Audio monitor control

The audio monitoring section (of an MCPM or MCE) provides 2 independent audio monitoring buses and a bus for audio metering. Panel buttons include a choice of 4 sources — program audio, preset audio, aux, or "off-air" audio — and a dedicated "dim" button for each bus, and independent monitor level controls knobs.

### 4 Audio level control

The audio level section includes 3 rotary knobs for adjusting the output level of the source selected on preset or program, and the over/main ratio for preset or program.

#### 5 Program/preset buttons

The program and preset "buses" include two rows of 16 buttons used for audio and video source selections and two rows of 8 "layer" buttons that select video effects and audio overs. Each button is dynamically "re-legendable."

The program bus corresponds to what is on program output at present. The preset bus allows you to premix a source with video effects and audio overs in preparation for a transition to the program bus.

#### 6 Breakaway buttons.

Two buttons at the left allow operators to perform video breakaway or audio breakaway.

#### 7 Transition buttons

The transition buttons include 2 groups: transition type, transition rate, and a larger orange button that initiates transitions. There are 5 transition types: cut, V-fade, cross-fade, cut-fade, and fade-cut. There are 3 transition rates: slow, medium, and fast. (The actual rates are configured in the current MCPM.)

#### 8 System buttons.

The system buttons include 3 buttons: 'Panel Lock', 'Automation Off', and master 'Fade to Black' by default. The configurer can redefine them.

#### 9 "Layer" buttons

The layer section is a part of the program/preset bus that allows you to combine video effects and audio overs with your main source selections. The layer section includes keyers, logos, a squeezeback generator, and audio "overs." (Some MCPMs do not support all effects.)

## FFCP Connectors

At the rear of the FFCP are 2 power connectors, one usable Ethernet connector, a 'CP Aux' connector, and a GPI/alarm connector. (See Figure 3-17 on page 69.)

### Power

There are 2 AC connectors, PS1 and PS2, for the sake of redundancy. You need not use both if you are not concerned with redundancy. The internal power supply modules include fans.

### Ethernet

The FCP has one usable RJ-45 Ethernet port. The FFCP connects to the Ethernet switch on the master control network. (The other RJ-45 port is not used.)

It is on this network that the FCP communicates with MCPMs and with the configuration software. You (or your system administrator) must provide a unique IP address for the FFCP.

Without the IP address, the FFCP cannot communicate with either the MCPMs or the configuration software. Use the Panel ID menu under the Panel Menu to set the IP address and IP subnet mask.

The default IP address is 192.168.7.100 and the subnet mask must always be 255.255.255.0.

## GPI/Alarm

The FFCP has a DB25 connector that supports GPI inputs, GPI outputs, and alarms:

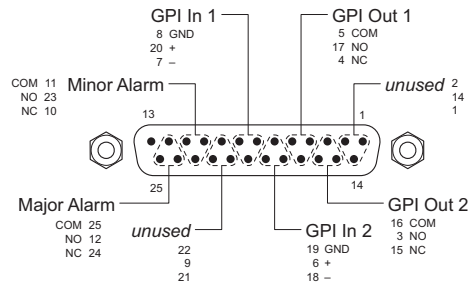

Refer to the GPI section in the *FFCP Operator's Guide* for connection information. See [Panel GPI](#) on page 193 for more information.

## 'CP Aux' Connector

The FFCP has a DB15 connector to which you connect the optional TLA.

## Ground Lug

Connect the ground lug, using 8–14 AWG copper wire to earth ground. (This is a safety measure and is not required for the control panel to operate.)

## PC GUI Summary

The PC GUI is a software control panel that runs on a PC connected to the master control network. It emulates the functions of the FFCP. Its menu section emulates the touchscreen menu of the FFCP. The GUI can be operated either with a mouse on any PC or by finger pressure on a touchscreen PC.

- ▲ The PC GUI does not support Imagestore 750 transition processors. It does not support some of the advanced features of MCEs or the MCPM-SDHD (e.g., aux/preview buses, dual-squeeze).
- ▲ The GUI window is 1244×931 pixels and requires a monitor at least that size to function. (The GUI window cannot be resized.)

Arrayed on this panel are 83 color-coded buttons and a menu with 4 associated up/down arrow pairs. The arrow pairs emulate the 4 menu knobs of the FFCP. Each button has 2 lines of text, 4 characters per line. Active buttons are either "light green," "green," "amber," or "red" and off, low-tally, or high-tally. Buttons that are unused are just grey. Red generally indicates an error condition. Buttons that are defined, but disabled momentarily, show dimmed text.

Figure 3-18 identifies the sections of the PC GUI:

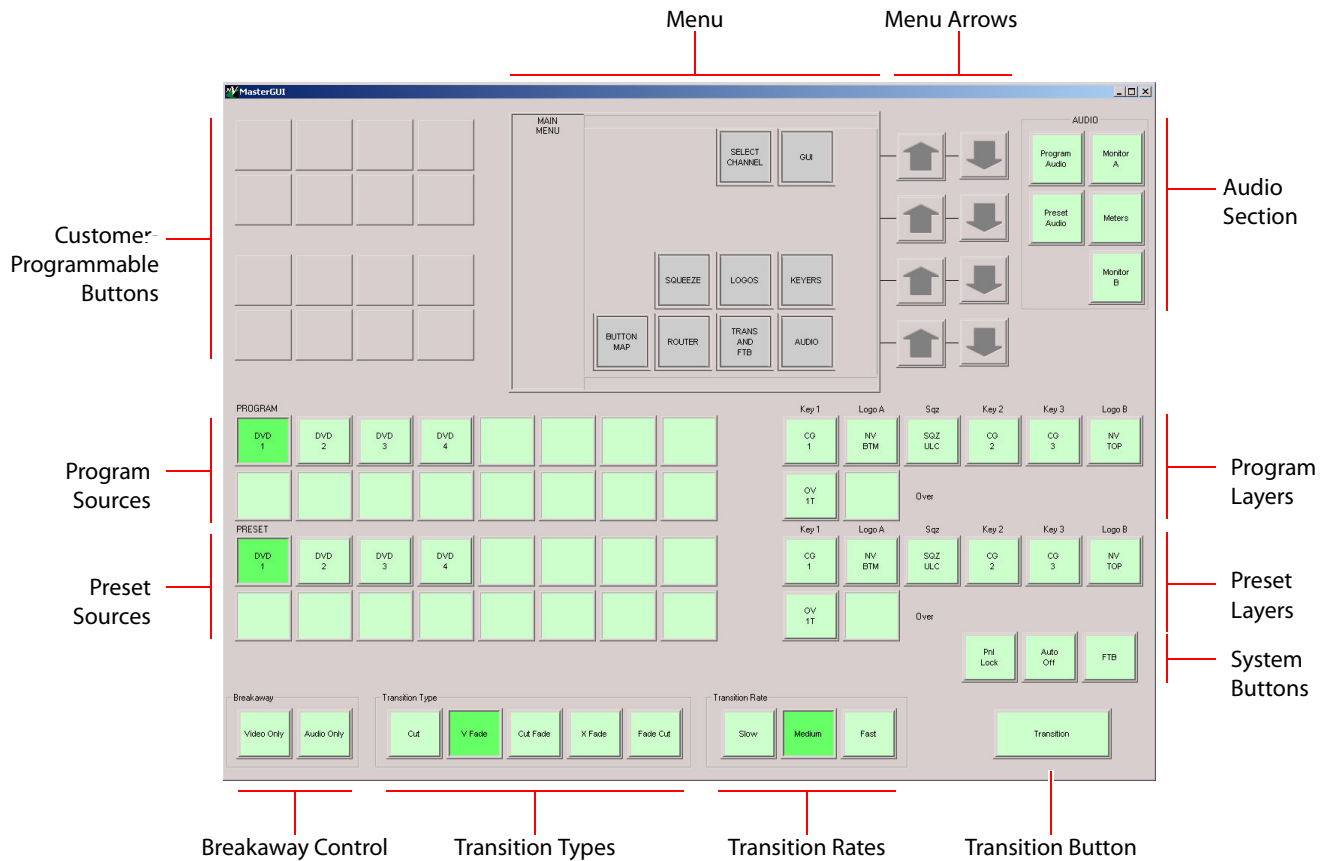

Fig. 3-18: PC GUI

- ▲ The PC on which the GUI runs must be set up to operate on the master control network.

## GUI Buttons

The buttons are large and appear in 4 colors (grey, light-green, green, amber, and red) and 3 brightness levels: off, low-tally, and high-tally. They are dynamically re-legendable, displaying 2 lines of text, 4 characters each. (The text might be blank.)

The buttons allow you to choose sources, options, video effects, audio functions, transition effects, and other functions.

Some buttons are *toggles*. Pressing a deselected toggle button will cause it to become selected. Pressing a selected toggle button will make it deselected.

Some groups of buttons operate as a mutually exclusive set. Pressing a deselected button will cause it to become selected and all other buttons in the set to become deselected. There are two types of mutually exclusive buttons:

- 1 Pressing a selected button makes it deselected. (All other buttons in the set remain deselected.)
- 2 Pressing a selected button leaves the button selected.

The GUI has a central system of menu buttons. It is through the menu that you can adjust operating parameters such as audio levels and keyer settings. If an MCPM configuration permits, the operator may not only select keyer settings, but modify them.

The GUI's "Transition" button is large and at the lower right.

## Absence of Knobs

The GUI has no knobs and no knob proxies. Values in the menu are either set or selected using the up/down arrow buttons next to the menu. (Arrows that are enabled are bright green.)

Audio monitor and audio output level functions are available in the menu. (Pressing a button in the audio section at the top right causes an audio menu to be displayed.)

## Functional Sections of the GUI

Following are brief descriptions of each section. Refer to Figure 3-18 on page 73.

### 1 Customer-programmable buttons

At the top left, the customer-programmable section includes 16 function buttons, each of which may be programmed to perform functions such as channel selection, GPI triggers, or transition control.

### 2 Menu

Using the menu, an operator can access all secondary system functions such as keyer settings, squeezeback presets and audio settings. Associated with the menu are 4 up/down arrow pairs for selection and adjustment of parameters.

### 3 Audio section

The audio monitoring section (of an MCPM or MCE) provides 2 independent audio monitoring buses and a bus for audio metering. The GUI's audio menus allow the choice 4 sources—program audio, preset audio, aux, or "off-air" audio—and a dedicated "dim" button for each bus, and independent monitor level controls. The audio menus also allow control of the audio output levels. You can adjust any level with the arrow buttons next to the menu.

The GUI's audio section (top right) provides shortcuts for accessing the audio menus.

### 4 Program/preset buttons

The program and preset "buses" include two groups of 16 buttons used for audio and video source selections, two rows of 6 video effect buttons, and two rows of 2 audio over buttons. Each button is dynamically "re-legendable."

The program bus corresponds to what is on program output at present. The preset bus allows you to premix a source with video effects and audio overs in preparation for a transition to the program bus.

The program and preset "layer" sections are a part of the program/preset bus that allows you to combine video effects and audio overs with your main source selections. The layers provide keyers, logos, a squeezeback generator, and audio "overs."

▲ Some MCPMs do not support all video effects.

### 5 Breakaway buttons.

Two buttons at the lower left allow operators to perform video breakaway or audio breakaway.



#### 6 Transition buttons

The transition buttons include 2 groups: transition type and transition rate, and a larger orange button that initiates transitions. There are 5 transition types. By default, they are cut, V-fade, cross-fade, cut-fade, and fade-cut. There are 3 transition rates. By default, they are slow, medium, and fast. (The actual rates are configured in the current MCPM.)

#### 7 System buttons.

The system buttons include 3 buttons: 'Panel Lock', 'Automation Off', and master 'Fade to Black' by default. The configurer can redefine them.

## Aux/Preview GUI Summary

The Aux/Preview GUI (a variant of the CECP GUI) is a software control panel that runs on a PC connected to the master control network. Its functions are a subset of the functions of the CECP GUI. Except for the disabled functions, it operates exactly the same as the CECP GUI.

The Aux/Preview GUI is intended to allow access to the aux and preview buses of an MCE, but disallow any changes to its program and preset buses.

- ▲ The Aux/Preview GUI window is also 1280×966 pixels and requires a monitor at least that size to function. (Although the GUI window can be resized, doing so prevents access to parts of the GUI.)

Arrayed on this panel are 95 color-coded buttons and a menu with 8 associated menu "knobs." The knobs are graphical of course and emulate the 8 menu knobs of the CECP.

Each button has 3 lines of text, 8 characters per line. Active buttons, like those of the CECP, are either green, red, amber, white, blue, or violet and off, low-tally, or high-tally. Buttons that are unused are just grey. Red generally indicates an error condition. Buttons that are defined, but disabled momentarily, show dimmed text.

High-tally buttons are brighter or lighter than buttons that are low-tally.

Figure 3-18 identifies the sections of the Aux/Preview GUI:

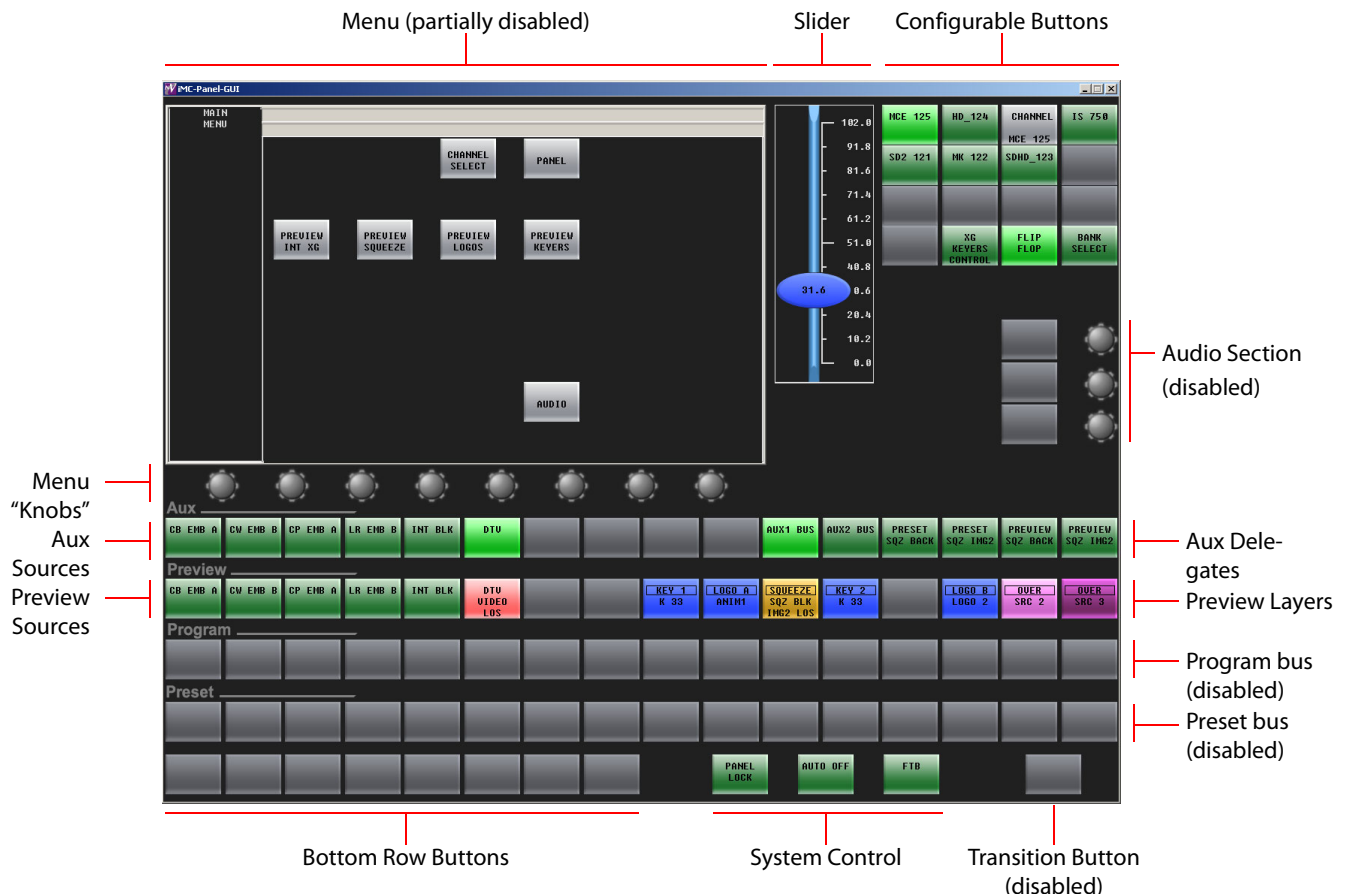

Fig. 3-19: CECP GUI

## GUI Buttons

The buttons are moderately large and appear in several colors (grey, green, amber, red, blue, violet, and white) and 3 brightness levels: off, low-tally, and high-tally. They are dynamically re-legendable, displaying 3 lines of text, 8 characters each. (The text might be blank.)

The buttons allow you to choose sources, options, video effects, audio functions, and other functions.

Some buttons are *toggles*. Pressing a deselected toggle button will cause it to become selected. Pressing a selected toggle button will make it deselected.

Some groups of buttons operate as a mutually exclusive set. Pressing a deselected button will cause it to become selected and all other buttons in the set to become deselected. There are two types of mutually exclusive buttons:

- 1 Pressing a selected button makes it deselected. (All other buttons in the set remain deselected.)
- 2 Pressing a selected button leaves the button selected.

The GUI also has a system of menu buttons. It is through the menu that you can adjust operating parameters such as audio levels and keyer settings. If an MCPM or MCE configuration permits, the operator may not only select keyer settings, but modify them.

The Aux/Preview GUI's preset bus and program bus are disabled. (Their buttons are dark gray). The audio section is also disabled.

The menu of the Aux/Preview GUI has fewer buttons than the menu of the CECG GUI.

The Aux/Preview GUI's "Transition" button is disabled (dark gray).

## Knobs and Slider

The GUI has knob "proxies" and a slider with which operators may change parameter values. The menu is associated with 8 knob proxies. The audio section has two knob proxies. The knob proxies do nothing by themselves. However, when you click a knob proxy, the slider appears. The slider is generally blue in color and allows coarse adjustments of a selected parameter.

An operator can perform fine adjustments of any parameter using the keypad buttons associated with a menu parameter.

## Functional Sections of the GUI

Following are brief descriptions of each section. Refer to Figure 3-7 on page 46.

### 1 Configurable buttons

At the top right, the configurable button section includes 16 function buttons, each of which may be programmed to perform functions such as channel selection, GPI triggers, or transition control.

### 2 Menu

Using the menu, an operator can access all secondary system functions such as keyer settings, squeezeback presets and audio settings. Associated with the menu are 8 menu knobs for selection and adjustment of parameters.

### 3 Audio section

Although the Aux/Preview GUI displays an audio section (at the middle right), its buttons and knobs are disabled (dark gray).

### 4 Program bus

The 16 buttons of the program bus are disabled.

### 5 Preset bus

The 16 buttons of the preset bus are disabled.

### 6 Preview bus

The preview bus allows a master control operator to experiment with main sources and video effects without interfering with on-air programming or with automation.

▲ The preview bus is enabled (active) only when the GUI controls an MCE.

### 7 Aux bus

The aux (auxiliary) bus consists of the same main sources that appear on the preview bus plus up to 4 "aux delegate" buttons. The different delegate buttons determine the function of the aux bus. The aux bus might or might not be related to the aux outputs of an MCE, depending on configuration. See [Aux Delegates](#) on page 125.

▲ The aux bus is enabled (active) only when the GUI controls an MCE.

## 8 Bottom row buttons

The bottom row buttons are an additional set of configurable buttons like those at the top right.

## 9 System control buttons.

By default, the system control buttons include 3 buttons: 'Panel Lock', 'Automation Off', and master 'Fade to Black. These are also configurable.

## 10 Transition button.

The transition button is disabled.

## SCP Summary

The SCP is a 3RU rack-mountable master control panel. It is 3.17" deep overall. At the front of the panel are 41 color-coded LCD buttons and 6 knobs (a.k.a. rotary encoders). Each LCD button includes a 64x32 graphic display that usually shows 3 lines of text, 8 characters per line. Sometimes a button can show graphics, as does the 'Transition' button at the lower right.

▲ The SCP does **not** support Imagestore 750 transition processors.

Figure 3-20 shows the location of the SCP's function buttons and knobs.

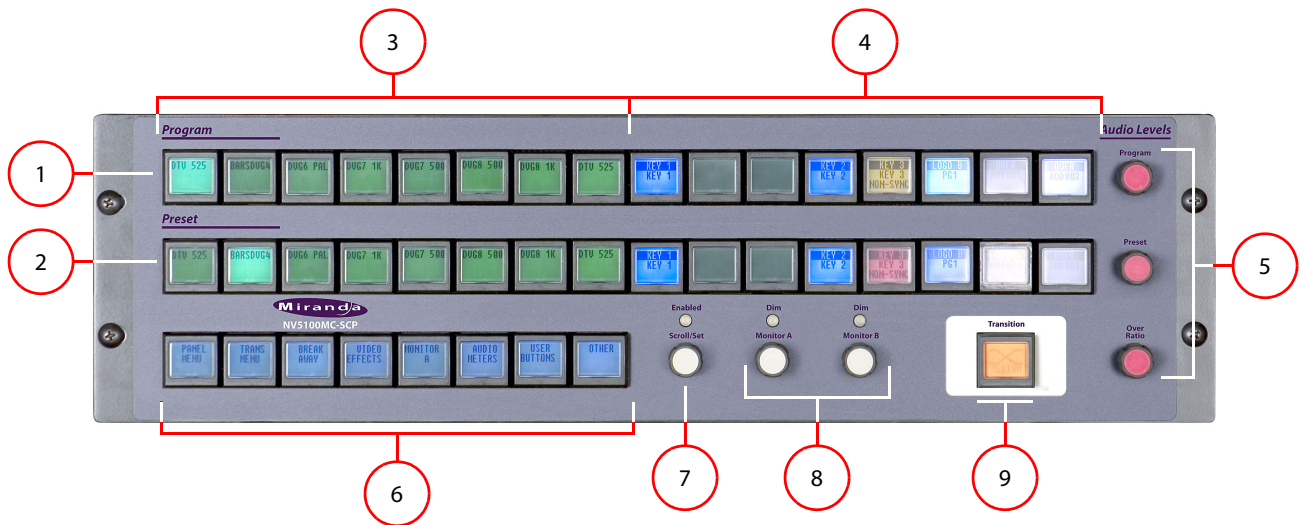

Fig. 3-20: Sections of the SCP

|                                       |                                     |                                      |
|---------------------------------------|-------------------------------------|--------------------------------------|
| 1 <a href="#">Program bus</a>         | 4 <a href="#">Layer buttons</a>     | 7 <a href="#">scroll/select knob</a> |
| 2 <a href="#">Preset bus</a>          | 5 <a href="#">Audio level knobs</a> | 8 <a href="#">Monitor knobs</a>      |
| 3 <a href="#">Main source buttons</a> | 6 <a href="#">Menu buttons</a>      | 9 <a href="#">Transition button</a>  |

Following are brief descriptions of each section:

## 1 Program bus

The 16 buttons of the program bus include *up to* 8 main source buttons and *up to* 12 "layer" buttons. The layer buttons can be configured as additional main sources, video effects, audio overs, or XG keyer layers.

Whatever main source, video effects, audio overs, and XG keyer layers are selected on the program bus form the *program* output of the MCPM that is currently controlled by the SCP.

## 2 Preset bus

The preset bus allows you to set up the state of the program output that will exist after the next transition.

The preset bus has the same button definitions as the program bus.

Whatever main source, video effects, audio overs, and XG keyer layers are selected on the preset bus form the *preset* output of the MCPM that is currently controlled by the SCP.

## 3 Main source buttons

The leftmost buttons (on program and preset) represent main sources only. Button mapping and router pre-select functions allow an operator to select sources from a large pool of sources.

A bank select button allows the operator to switch between two banks of “virtual” main source buttons. Each of the layer button pairs at the right can be configured as a main source. The number of virtual buttons is limited (by the architecture of the MCPM or MCE) to 16.

Source buttons are usually green, high or low tally, except when a source is used as an audio breakaway. Then, it is violet. If a main source has a problem (e.g., LOS), it is bright amber when unselected and red when selected.

## 4 Layer buttons

The rightmost buttons (on program and preset) can be configured to represent additional main sources, video effects audio overs, and XG keyer layers. Video effects include keyers, logos, and squeezeback.

Although it is possible to order the layer buttons in any way, the ordering of video effects and audio overs is fixed in the MCPM where they are actually executed. Video effects are downstream of *all* main sources. Audio overs are also downstream of all main sources.

Video effect buttons are blue, and high-tally when selected. Audio over buttons are violet. If a problem exists (e.g., LOS), the button is bright amber when unselected and red when selected.

## 5 Audio level knobs

There are 3 rotary knobs for adjusting the audio output level of the source selected on preset or program, and the audio “over/main” ratio for either preset or program.

## 6 Menu buttons

The 8 menu buttons allow the operator to view the state of MCPM parameters and SCP parameters and to select sources, effects, and overs. The menu structure is hierarchical (or tree-structured). There are two kinds of menus: system-defined and customer-defined.

The menu provides functions such as system status, audio status, channel selection, triggering GPI events, and panel lock.

(It is in the menu that operators set the transition type and transition rate. Other control panels have dedicated physical buttons for these functions.)

## 7 Scroll/select knob

The scroll/select knob allows you to scroll through lists of options, sources, and other items as you make menu selections. The LED above the knob lights when scrolling is enabled.

### 8 Monitor knobs

An MCPM has 2 audio monitor buses, A and B. The 2 monitor knobs allow you to increase or decrease the audio monitor levels. You can “dim” (attenuate) the monitor level using an audio menu. When the monitor is dimmed, the LED above the monitor knob lights.

(Menu functions exist for MCPM meter outputs, but there are no meter knobs.)

### 9 Transition button

The transition button displays the transition type (as a graphic) and the transition rate (in text). It is always bright orange.

Pressing the transition button initiates a transition in the MCPM according to the SCP setup. An operator can change the transition rate and type using the menu.

## SCP Buttons

Buttons appear in several colors and 3 brightness levels: off, low-tally, and high-tally.

Buttons allow you to choose sources and video effects and to make menu selections. Some buttons display status. Pressing a button usually selects something. However, nothing happens when you push a button that is disabled or off and nothing happens when you push a button that merely displays status.

The buttons on the panel display the following colors:

|            |           |             |             |       |            |
|------------|-----------|-------------|-------------|-------|------------|
| Low Green  | Low Blue  | Low Violet  | Low Orange  | Gray  | High Red   |
| High Green | High Blue | High Violet | High Orange | White | High Amber |

In addition to these 12 colors, a button can be dark (that is, off, or having no color). High-tally red and high-tally amber usually indicate warnings.

The following color scheme usually applies. Exceptions will be noted.

- Non-selected state: low tally — green, blue, violet, or orange.
- Selected state: high tally — green, blue, violet, orange, or red.
- Navigation: gray.
  - ▲ A gray button is always safe to press because it will never impact the MCPM behavior.
- Status: white with black letters. (Status buttons do nothing when pressed.)

Some buttons are *toggles*. Pressing a deselected toggle button will cause it to become selected. Pressing a selected toggle button will make it deselected.

Some groups of buttons operate as a mutually exclusive set. Pressing a deselected button will cause it to become selected and all other buttons in the set to become deselected. There are two types of mutually exclusive buttons:

- 1 Pressing a selected button makes it deselected. (All other buttons in the set remain deselected.)
- 2 Pressing a selected button has no effect: the button remains selected.

## SCP Knobs

Turning a knob clockwise increases the associated value until the maximum value is reached. After that, turning the knob clockwise has no effect.

Turning the knob counter-clockwise decreases the associated value until the minimum value is reached. After that, turning the knob counter-clockwise has no effect.

The function assigned to a knob might be disabled. In that case, turning the knob does nothing. For instance, when a list contains 7 or fewer items, scrolling through the list is disabled, and the knob is also disabled. The LED above the scroll knob illuminates when scrolling is enabled.

## Connectors

At the rear of the panel are two power connections, an Ethernet port, a fan, and a GPI/alarm connector. See [Panel GPI](#) on page 193 for more information.

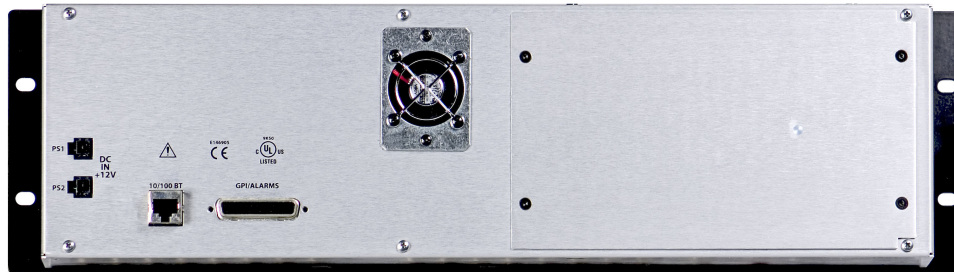

Fig. 3-21: SCP (rear view)

## Misc. Topics

### Channel Selection

A master control system can include one or more MCEs, MCPMs, and Imagestore750s. Each MCE, MCPM, and Imagestore 750 is considered a channel. A control panel can be configured with buttons that select channels.

A panel can also be configured with (one) default channel. This is the channel to which the panel connects when it resets. If the default channel is the only channel, there is no need to configure any channel selection buttons.

The default channel can be an MCE, an MCPM, or an Imagestore 750.

- ▲ There are two places in the configuration editor to designate the default channel: in the channel select table for MCEs and MCPMs, and in the channel table for Imagestore 750s. Setting the default channel in either table clears the entry from the other table because there can be only one default channel.

A panel can gang-control up to 4 channels (either MCEs and MCPMs or Imagestore 750s). The channels must either be Imagestore 750s or a mix of MCEs and MCPMs).

If the default channel is the main channel of an automatic channel gang, all channels of the channel gang are selected when the default channel is selected.

### IP Addresses

MCPMs are identified by their IP addresses on the master control network. Control panels are likewise identified by their IP addresses. To read or write a panel during configuration, you must know its IP address.

The configuration editor (and MasterDiag) can be used to search the master control network for MCPMs (including MCEs), control panels, and NV9000 systems. The search tool displays the IP addresses of devices it finds. The search tool is useful if you cannot remember an IP address.

During operation, a panel can control up to 4 channels. (The channels are said to be “ganged.” Channels can be ganged by default. See [Automatic Gang Mode](#) on page 107.)

During operation, up to 4 panels can control a single channel. The potential for interference exists.

## Flip-Flop Mode

A control panel can be configured to start in either flip-flop or flip-only mode. The default mode is “flip-only.” In flip-only mode, when an operator presses the Transition button, the preset bus selections transition to program and *remain* on preset. Both buses are *identical* at this point.

The alternative is called “flip-flop” mode, where the program and preset bus selections swap after the transition.)

You can configure a panel button to toggle the panel between flip-only mode and flip-flop mode.

- ▲ You should note that flip-flop and flip-only modes are transition properties and belong to the MCPM or MCE executing a transition. However, we say the panel is in flip-flop mode when it issues flip-flop transition commands to the MCPM or MCE prior to every transition. We say the panel is in flip-only mode when it issues flip-only transition commands to the MCPM or MCE.
- ▲ Flip-flop mode and flip-only mode do not apply to Imagestore 750s.
- ▲ Certain video effects can be configured to be removed from the preset bus after a transition. This option is overridden by flip-flop transitions.
- ▲ The Aux/Preview GUI does not support flip-flop mode because it does not support transitions of any kind.

## Modifiable Buttons

When a panel is controlling an MCE or MCPM, any of the main source buttons<sup>1</sup> can be a “router pre-select” button. When a button is so designated, the operator can assign a router source to the button. The button’s legend will show the new source mnemonic, and audio and video from that router source will be available for use.

- ▲ Router pre-select buttons require the presence of an NV9000 router control system.

Any source button can be configured as a “user-modifiable” button or “system-modifiable” button, or both, where the operator or automation, respectively, can assign any source defined in the MCPM configuration to the button.<sup>2</sup> The source’s name then appears on the button and the source can be selected.

Both main source buttons and over source buttons can be reassigned in these ways.

- ▲ The Aux/Preview GUI does not support router pre-select.
- ▲ Router pre-select does not apply to Imagestore 750s.

---

1. Strictly speaking, any of the 16 *virtual* main source buttons can be a router pre-select button. That is because such a designation is defined in the main source button configuration of the MCPM or MCE.  
2. Similarly, any of the *virtual* buttons can be operator- or system-modifiable.



# 4 Editor Basics

Chapter 4 describes the menus and structure of the MCS Panel Configuration Editor and provides some orientation.

## Topics

|  |    |
|--|----|
| <a href="#">Editor Overview</a> .....          | 83 |
| <a href="#">GUIs — Special Treatment</a> ..... | 86 |
| <a href="#">Menus</a> .....                    | 87 |
| <a href="#">Guidelines</a> .....               | 98 |

## Editor Overview

The configuration editor application is for generating, storing, editing, and uploading the configuration files used by master control panels. Each control panel can have a unique configuration file, or several control panels can share common settings.

When you first launch the configuration editor, it displays a welcome page and a panel list:

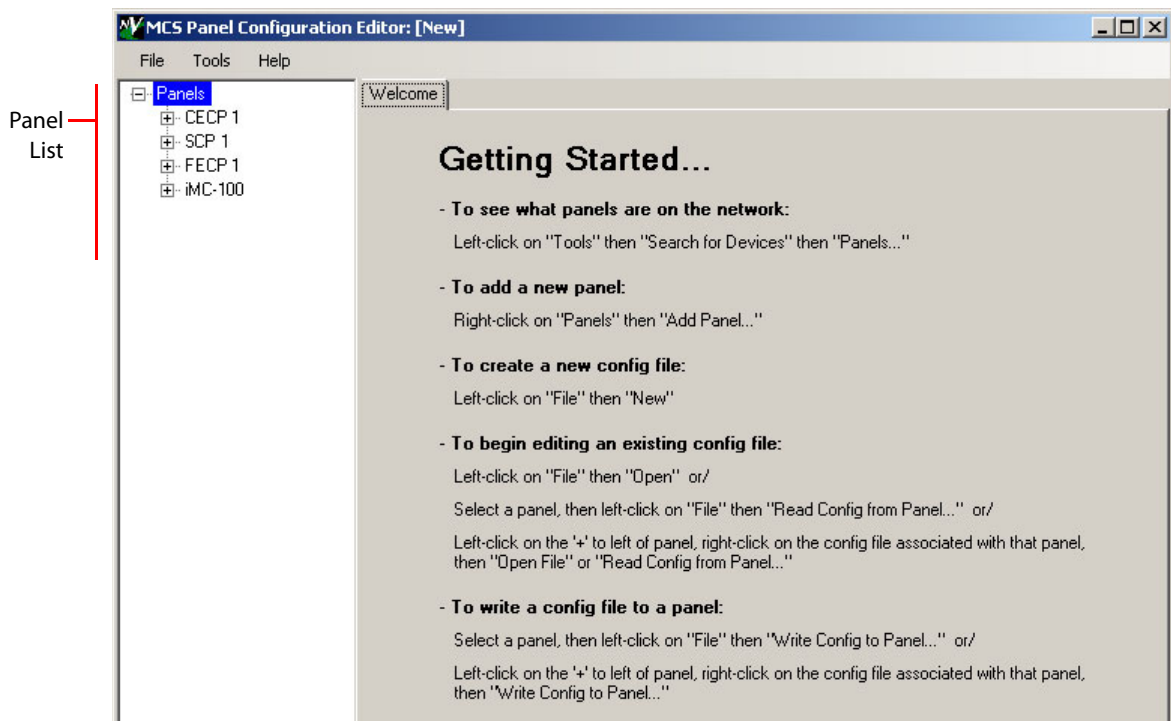

The welcome page gives a synopsis of what you can do and where to start. The welcome page disappears when you exercise the 'File' menu (to create, open, or read a configuration).

This is the configuration editor window with the 'General Settings' page active, which appears when you create a new configuration (in Figure 4-1, for an iMC-Panel-300):

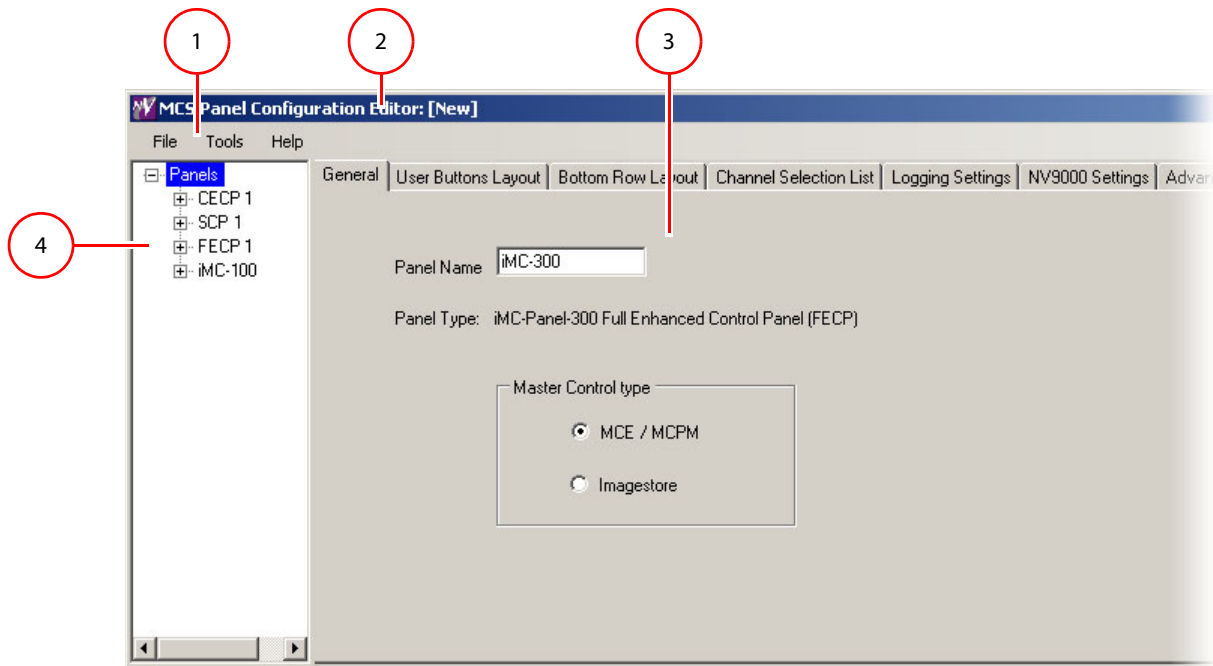

Fig. 4-1: MCS Panel Configuration Editor — General Settings (iMC-Panel-300 Sample)

- 1 [Menu bar](#)      2 [Title bar](#)      3 [Tabbed work area.](#)      4 [Panel list area](#)

Following are descriptions of each main window feature.

1 Menu bar

The menu bar provides access to configuration functions. See [Menus](#) on page 87 for details.

2 Title bar

If you have a file open, the title bar shows the name of the configuration file that you are currently editing. It displays “[New]” if you have a new configuration that you have not saved.

3 Tabbed work area.

The work area contains several tabbed configuration pages in which you can enter data. The pages presented vary according to the type of control panel you have chosen to configure.

For certain panels (the iMC-Panel-100, iMC-Panel-200, iMC-Panel-GUI, and iMC-Panel-300) the configuration pages are divided into two sets, one set for when the panel is controlling an MCE or MCPM, and another set for when the panel is controlling an Imagestore750. You can choose the set with which to work at any time in the ‘General’ page, as shown in Figure 4-1.

Configuration pages applicable to MCEs and MCPMs, shared by most panels types, include:

- |  |                                    |                                   |
|--|------------------------------------|-----------------------------------|
| <a href="#">General</a>                | <a href="#">User Button Layout</a> | <a href="#">Bottom Row Layout</a> |
| <a href="#">Channel Selection List</a> | <a href="#">Logging Settings</a>   | <a href="#">NV9000 Settings</a>   |
| <a href="#">Advanced</a>               | <a href="#">Button Assignments</a> | <a href="#">Aux Delegates</a>     |

Configuration pages applicable to the Imagestore 750 include:

|  |                                    |   |
|--|------------------------------------|---|
| <a href="#">General</a>                | <a href="#">User Button Layout</a> | <a href="#">Bottom Row Layout</a>       |
| <a href="#">Channel Selection List</a> | <a href="#">Logging Settings</a>   | <a href="#">NV9000 Settings</a>         |
| <a href="#">Advanced</a>               | <a href="#">Button Assignments</a> | <a href="#">Audio Monitoring Layout</a> |
| <a href="#">Aux Row</a>                | <a href="#">Preview/User Row</a>   | <a href="#">Monitor Wall</a>            |

(The 'Audio Monitoring Layout' page is available only for FECPs and iMC-Panel-300s.)

The configuration pages for MCEs and MCPMs are described in chapter 5 and the configuration pages for Imagestore 750s are described in chapter 7.

Most panels (the CFCP, SCP, CECP, CECP M1, iMC-Panel-100, iMC-Panel-200, and iMC-Panel-GUI) allow "virtual button bank selection," and arbitrary ordering of video effect and over buttons. These panels have a [Button Assignments](#) page in addition to other configuration pages. The button assignments page for Imagestore 750s differs from the button assignments page for MCEs and MCPMs.

The FECP and iMC-Panel-300 do not allow "bank selection," but do allow arbitrary ordering of video effect and over buttons (in the [Button Assignments](#) page).

The SCP is unique because its menu is implemented on buttons. Instead of 'User Button Layout' and 'Bottom Row Layout' configuration pages, it has [User Menu Lists](#) and [Menu Layouts](#) configuration pages.

The CECP, CECP M1, CECP GUI, Aux/Preview GUI, FECP, iMC-Panel-100, iMC-Panel-200, iMC-Panel-GUI, and iMC-Panel-300 have an aux/user button row. The use of aux/user buttons for Imagestore 750s differs from the use of aux/user buttons for MCEs, so the configuration page for Imagestore 750s differs from the configuration page for MCEs.

For MCEs, the configuration editor provides an [Aux Delegates](#) configuration page for these panels. (See page 125.)

For Imagestore 750s, the configuration editor provides an [Aux Row](#) configuration page for these panels. (See page 175.)

The CECP, CECP GUI, Aux/Preview GUI, FECP, iMC-Panel-100, iMC-Panel-200, iMC-Panel-GUI, and iMC-Panel-300 have a preview/user button row. The use of preview/user buttons for Imagestore 750s differs from the use of preview/user buttons for MCEs, so the configuration page for Imagestore 750s differs from the configuration page for MCEs.

For MCEs, the configuration editor has no additional page for the preview/user buttons.

For Imagestore 750s, the configuration editor provides a [Preview/User Row](#) configuration page for these panels. (See page 176.)

The iMC-Panel-300 has a configurable monitor/meter section. The button assignments page for Imagestore 750s differs from the button assignments page for MCEs and MCPMs. See the [Audio Monitoring Layout](#) page for MCEs and MCPMs on page 127. See the [Audio Monitoring Layout](#) page for Imagestore 750s on page 174.

Most panels provide an [Audio Macros](#) page. Audio macros exist for MCEs and MCPMs only.

▲ Audio macros must not be confused with GPI macros of the Imagestore 750.

#### 4 Panel list area

The panel list area displays a list of names and IP addresses for hardware control panels in the master control network. The list is expandable and collapsible as if it were tree-structured. (Sometimes the panel list is called a *panel tree*.) The list includes IP addresses and names for the panels.

- ▲ Be aware that the panel list contains IP addresses by which the configuration editor *attempts* to communicate with the panels. The list can include entries for panels that do not exist or that have been taken out of service.
- ▲ When you launch the configuration editor for the first time, the list will be empty unless someone else populated it.

If you highlight an IP address in the list, or the name of a panel, it becomes the “current” or “default” address. If the IP address corresponds to an actual panel, you can read from and write to the panel.

You can adjust the width of the list area by dragging its right-hand border. You can add, rename, and delete entries in the list area. You can change their IP addresses.

- ▲ The list does **not** include GUIs.

When you first launch the configuration editor, the list might be empty. You can add panels to the tree and delete panels from the tree.

If you read a file from a control panel or write a file to a control panel, the file’s pathname appears under the IP address in the tree.

- ▲ You can create and save configuration files off-line, that is, without control panels connected.

## GUIs—Special Treatment

By default, the CECF GUI, the Aux/Preview GUI, and the iMC-Panel-GUI are all named `cecp_gui.exe`. Immediately after installation of the GUI (from the SB0244 CD), there is exactly one such file in the bin folder. Furthermore, these GUIs all use the same configuration file: `cecp_gui.uicfg`.

The GUI executable file and its configuration file must be in the same folder.

If you intend to operate more than one of these GUIs on the same PC, it is necessary to create a separate instance of the executable file and the configuration file in separate folders for each copy of the GUI you want to run. You can name the executables anything you like. The configuration files must be named `cecp_gui.uicfg` to be recognized.

## Configuration Files

The handling of configuration files is very different for GUIs and hardware control panels.

### Hardware Control Panels

To transfer configuration files to and from hardware control panels, use the ‘Read Config from Panel...’ and ‘Write Config to Panel...’ commands from the File menu.

After reading a configuration file from a control panel, you may open it for editing.

After writing a configuration file to a control panel, the configuration editor prompts you to restart the panel with the new configuration.<sup>1</sup> Normally you would say ‘Yes’ to this prompt. If you say ‘No’, you can restart the panel later with its new configuration by pressing the ‘Update Config’ button under the ‘Panel’ menu at the panel. An ‘Update Config’ takes about 1 second.

---

1. The CFCF and FFCF, legacy panels, do not support restart after the write of the configuration. For these panels, you must go to the panel and press ‘Update Config’ to restart the panel

The 'Restart Panel' command under the 'Panel' menu causes a complete restart and takes much longer.)

Whatever configuration is loaded in the panel starts automatically whenever the panel starts.

## GUIs

Because the GUIs run on a PC, they read their configurations from specific files in their own folder. To reconfigure a GUI, copy a valid GUI configuration file into the GUI's folder.

You can distribute configuration files to any PC using ordinary methods (copy and paste). You can transport the file(s) on a USB memory device if your PCs do not share a common file system.

▲ Be careful about where you store working copies of configuration files. If you overwrite a GUI's configuration file, the GUI might not work. Please maintain a backup copy of these files.

## PC GUI

The PC GUI is *old* software. Its default pathname is:

```
C:\ProgramFiles\Miranda\MasterControl\bin\MasterGUI.exe
```

Its configuration file must be named `MasterGUI.uicfg`.

## iMC-Panel-GUI, CECP GUI, Aux/Preview GUI

These three GUIs are newer software. They share the same default pathname:

```
C:\ProgramFiles\Miranda\MasterControl\bin\cecp_gui.exe
```

Their configuration file *must be* named `cecp_gui.uicfg`.

If you have more than one instance of the GUI, the instances must reside in separate folders.

The Aux/Preview GUI is actually just a configuration option of the CECP GUI.

## Menus

This is the Menu Bar:

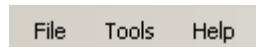

Each menu is described in detail in the following sections.

- [File Menu](#)
- [Tools Menu](#)
- [Help Menu](#)

## File Menu

This is the 'File' menu:

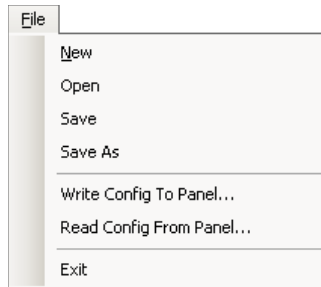

## New

Click 'New' to create a completely new configuration file. If you have not saved changes to current configuration data, you will be asked whether you want to save changes. You will also be asked for a control panel type:

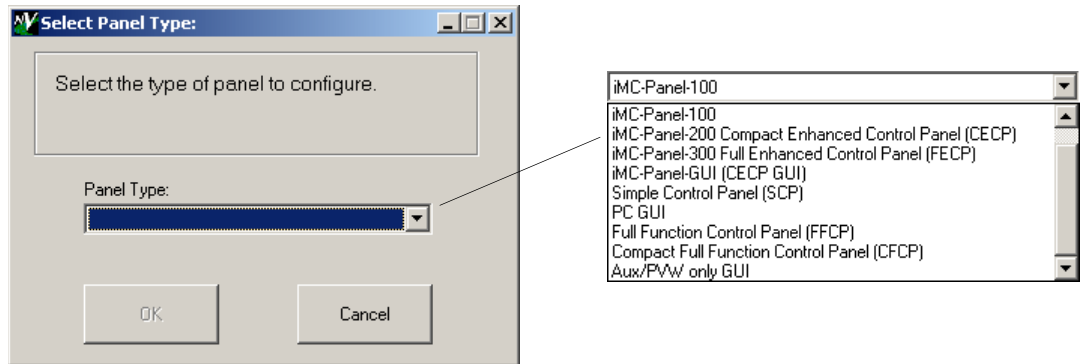

You can select one of 9 panel classes from the drop-down list. (Three of the classes include more than one panel type.) After you make the choice, the new configuration is locked to that panel class. If you inadvertently make the wrong choice, simply create another panel configuration.

The configuration pages that appear subsequently depend on which panel class you choose.

These are the classes and the panel types for each class:

| Class   | Panel Types                  |
|---|------------------------------|
| Simple Control Panel (SCP)                          | SCP                          |
| iMC-Panel-100 Rack-Mount Control Panel              | iMC-Panel-100                |
| iMC-Panel-200 Compact Enhanced Control Panel (CECP) | iMC-Panel-200, CECP, CECP M1 |
| iMC-Panel-300 Full Enhanced Control Panel (FECP)    | iMC-Panel-300, FECP          |
| iMC-Panel-GUI (CECP GUI)                            | iMC-Panel-GUI, CECP GUI      |
| PC GUI  | PC GUI                       |
| Full-function control panel (FFCP)                  | FFCP                         |
| Compact full-function control panel (CFCP)          | CFCP                         |
| Aux/PVW only GUI                                    | Aux/Preview GUI              |

The four iMC panels can control Imagestore 750s; other panels cannot. All the panels in the same class share configurations.

- ▲ If your system has older panels (e.g., CECP or FECP) their firmware should have been updated to conform to the current software release (of which the configuration editor is part).

If you choose 'iMC-Panel-200 Compact Enhanced Control Panel (CECP)'; a dialog with a drop-down menu appears so that you choose either a CECP (or an iMC-Panel-200) or a CECP M1:

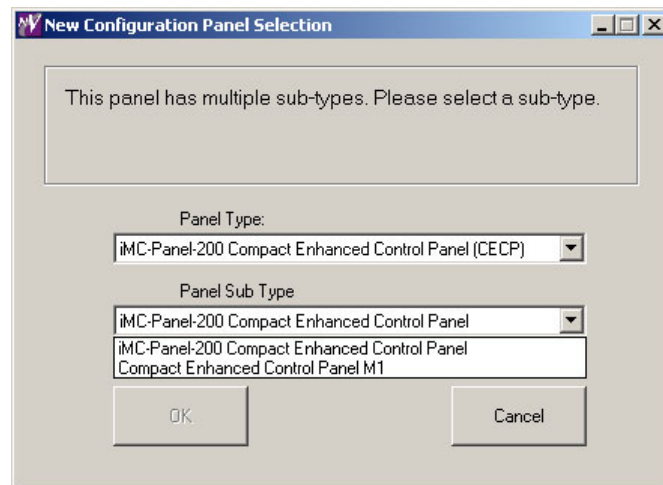

The CECP M1 is distinguished by having two metering inputs, no joystick, and no preview buttons. It does not control Imagestore 750s.

## Open

Click 'Open' to display the standard Open dialog, which allows you to open an existing configuration file for editing. If you have not saved changes to current configuration data, you will be asked whether you want save changes.

## Save

Click 'Save' to save the current configuration as a file in your PC's file system.

## Save As

Click 'Save As' to save the current configuration to a file with another name.

## Write Config to Panel

Click 'Write Config to Panel...' to write a configuration to a hardware control panel. A 'Write Configuration to Panel' dialog appears:

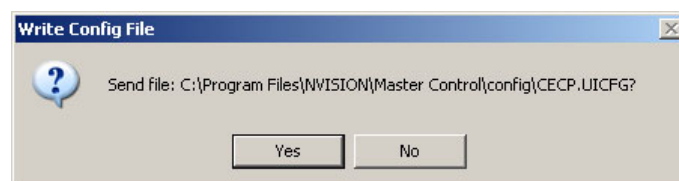

This dialog allows you to confirm that you have the correct configuration file selected.

The command transfers the configuration data from the file to the control panel. Click 'Yes' to start the transfer. Click 'No' if you do not want to perform the transfer.

After the transfer completes (it takes about a second) the configuration editor asks you whether you want the control panel to reset using the new configuration:

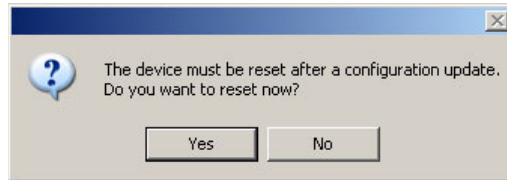

Click 'Yes' to initiate the reset. Click 'No' if you do not want to perform the reset at this time.

Note that if you have not selected a panel to configure, the editor will ask you to select one:



Note that if the panel does not exist, or if there is a network problem, the editor displays an error message:

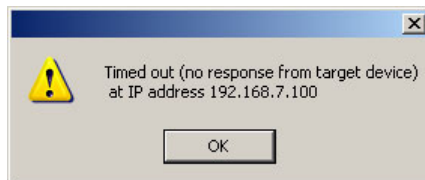

- ▲ 'Write Config to Panel...' does **not** write configuration files to GUIs. See [GUIs — Special Treatment](#) on page 86 for information.



## Read Config from Panel

Click 'Read Config from Panel...' to read a configuration from a hardware control panel. A 'Select config file name to save to' dialog appears:

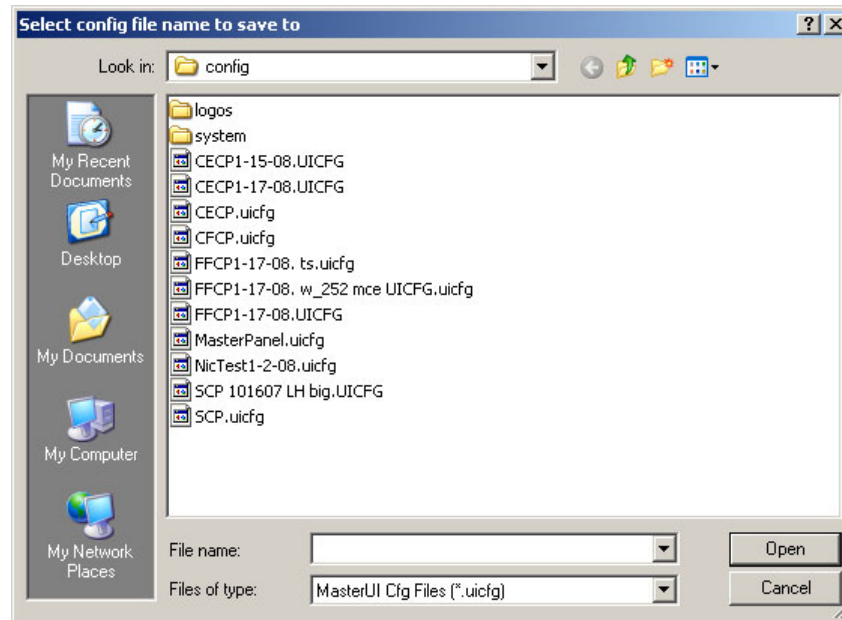

This is a standard save dialog. You can browse to create a configuration file or to select a configuration file. File extensions for panel configuration files are either **.cfg** or **.uicfg**.

The command transfers the configuration data from the control panel to the file. Click 'OK' to start the transfer. Click 'Cancel' if you do not want to perform the transfer.

After the transfer takes place, the configuration editor tells you whether the transfer was successful. If it was, the editor asks you whether you want to open the file for editing:

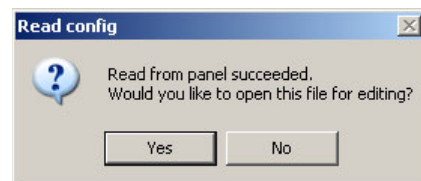

Click 'Yes' to open the file. Click 'No' if you do not want to open the file.

▲ 'Read Config from Panel...' does **not** read configuration files from GUIs. See [GUIs — Special Treatment](#) on page 86 for information.

## Exit

Click 'Exit' to quit the configuration editor. If you have not saved changes to current configuration data, you will be asked whether you want save changes.

## Tools Menu

This is the 'Tools' menu:

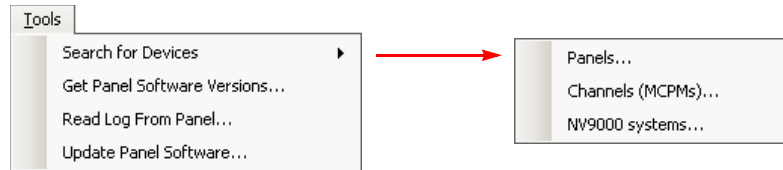

## Search for Devices

The 'Search for Devices' command displays a submenu of 3 search commands.

- Panels

The configuration editor searches the master control network for hardware control panels (but not software control panels). It produces a report such as this:

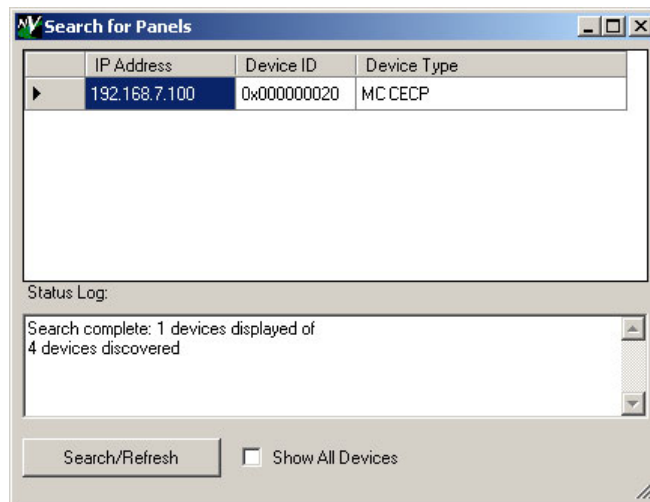

If you check the 'Show All Devices' box, the configuration editor produces a list of all Miranda devices on the master control network.

- Channels (MCPMs)

The configuration editor searches the master control network for MCPMs and MCEs. It produces a report such as this:

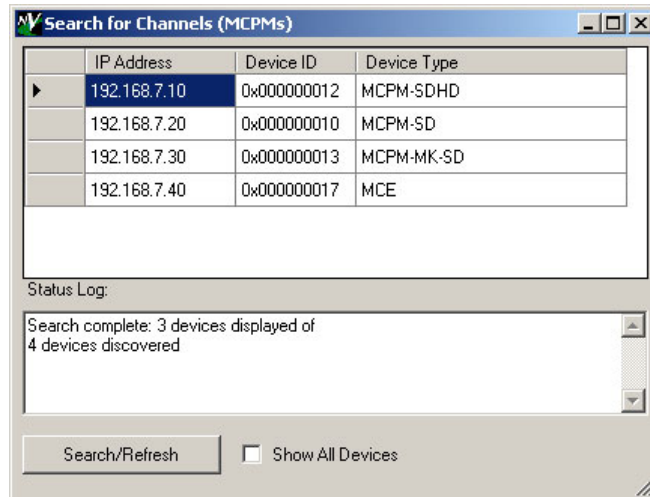

▲ The search method *does not* detect Imagestore 750s.

- NV9000 systems

The configuration editor searches the master control network for NV9000 system controllers. It produces a report such as this:

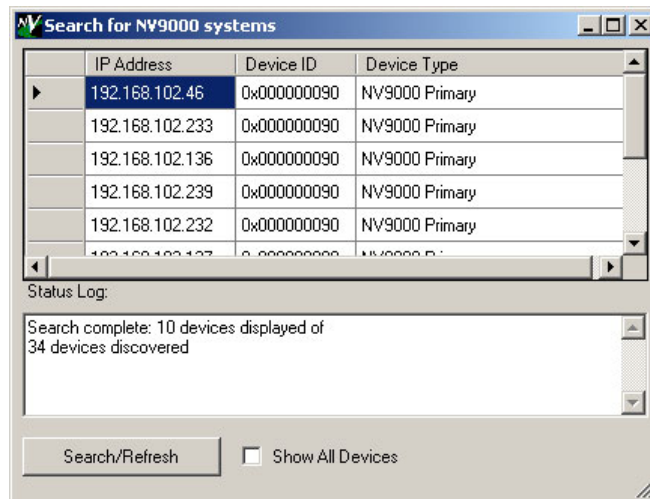

If there are no NV9000 system controllers present, the list will be empty.

## Get Panel Software Versions

Click 'Get Panel Software Versions...' displays a list of software modules within the panel. The software differs depending on the panel type. This is a sample of a report for the iMC-Panel-200:

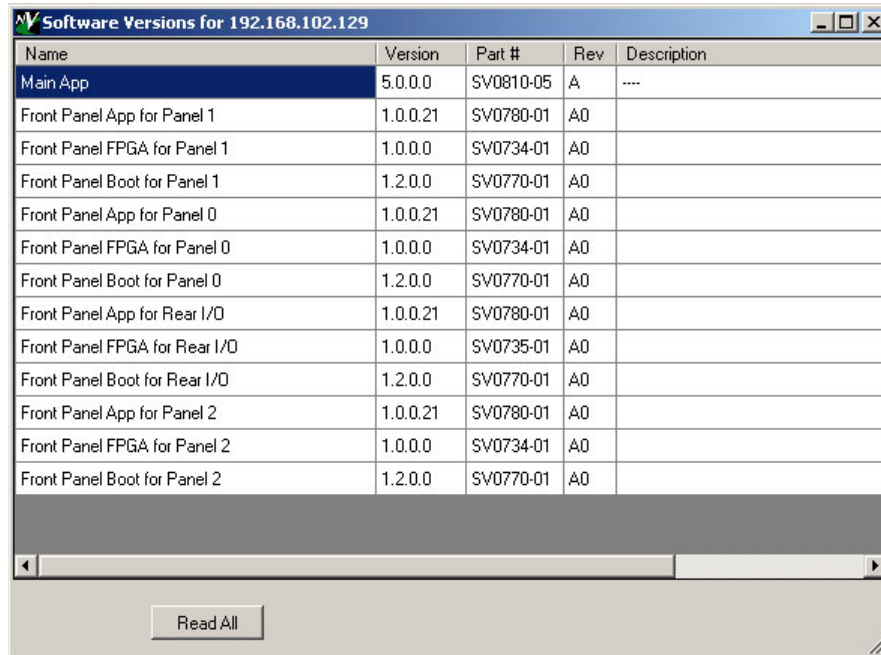

| Name                          | Version  | Part #    | Rev | Description |
|-------------------------------|----------|-----------|-----|-------------|
| Main App                      | 5.0.0.0  | SV0810-05 | A   | ----        |
| Front Panel App for Panel 1   | 1.0.0.21 | SV0780-01 | A0  |             |
| Front Panel FPGA for Panel 1  | 1.0.0.0  | SV0734-01 | A0  |             |
| Front Panel Boot for Panel 1  | 1.2.0.0  | SV0770-01 | A0  |             |
| Front Panel App for Panel 0   | 1.0.0.21 | SV0780-01 | A0  |             |
| Front Panel FPGA for Panel 0  | 1.0.0.0  | SV0734-01 | A0  |             |
| Front Panel Boot for Panel 0  | 1.2.0.0  | SV0770-01 | A0  |             |
| Front Panel App for Rear I/O  | 1.0.0.21 | SV0780-01 | A0  |             |
| Front Panel FPGA for Rear I/O | 1.0.0.0  | SV0735-01 | A0  |             |
| Front Panel Boot for Rear I/O | 1.2.0.0  | SV0770-01 | A0  |             |
| Front Panel App for Panel 2   | 1.0.0.21 | SV0780-01 | A0  |             |
| Front Panel FPGA for Panel 2  | 1.0.0.0  | SV0734-01 | A0  |             |
| Front Panel Boot for Panel 2  | 1.2.0.0  | SV0770-01 | A0  |             |

This is a sample of a report for the SCP:



| Name             | Version  | Part #    | Rev | Description |
|------------------|----------|-----------|-----|-------------|
| Main App         | 4.9.0.0  | SV0718-04 | C   | ----        |
| Front Panel App  | 1.1.2.11 | SV0771-01 | B0  |             |
| Front Panel FPGA | 1.0.0.0  | SV0682-02 | A0  |             |
| Front Panel Boot | 1.1.0.99 | SV0739-01 | A0  |             |

Software and firmware that are out-of-date, but not critically so, are indicated by yellow highlighting.

Software and firmware that are critically out-of-date are indicated by red highlighting.

## Read Log from Panel

Click 'Read Log from Panel...' to read an event log file from a hardware control panel. A dialog appears in which you can choose the location in your file system in which to save the file:

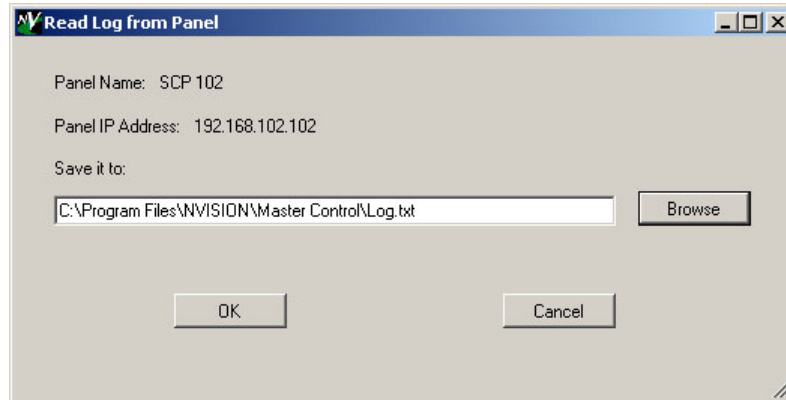

The GUI handles log files differently. The GUI keeps its log in a hidden temporary file. When an operator issues a 'Save Log' command from the GUI, the GUI writes the log to C:\log.txt. It will overwrite that file every time the operator issues the 'Save Log' command.

The log file includes event determined by the logging levels selected in the 'Logging Settings' configuration page.

- ▲ For "legacy" panels (FCFP, FFCP), we recommend that you issue a 'Save Log' command prior to reading the log from the panel. The save is automatic on the SCP, iMC-Panel-100, iMC-Panel-200, iMC-Panel-300.

Reading the log from the panel does not clear the log.

- ▲ 'Read Config from Panel...' does **not** read configuration files from GUIs.

## Update Panel Software

Click 'Update Panel Software...' to update the application software within a hardware control panel. An 'Update Panel Software' dialog appears. The dialog differs among the panel types.

### FFCP, CFCP, SCP

For certain panel types — FFCP, CFCP, SCP — the configuration editor allows you to update the panel's application only. This illustration shows the dialog for an FFCP:

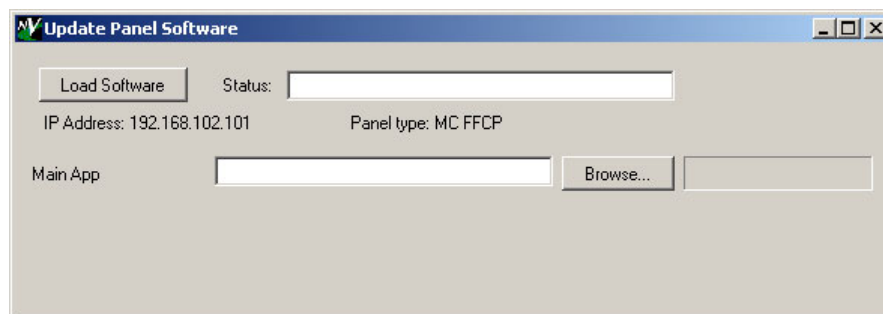

When you have selected the software or firmware, click 'Load Software' and wait for the configuration editor to indicate successful completion. This might take several minutes. Be patient. A

progress bar gives you some indication of progress, but do not consider the update finished until you get a successful completion message.

At the least, the update dialogs shows the control panel's IP address, making it evident which panel is being updated. You must browse to find the appropriate software or firmware to upload.

### iMC-Panel-100, iMC-Panel-200, iMC-Panel-300, CECP, CECP M1, FECP

For these panels, the configuration editor allows you to update the entire panel using a single ".nvz" file. This is the 'Update Panel Software' dialog for a CECP, for example:

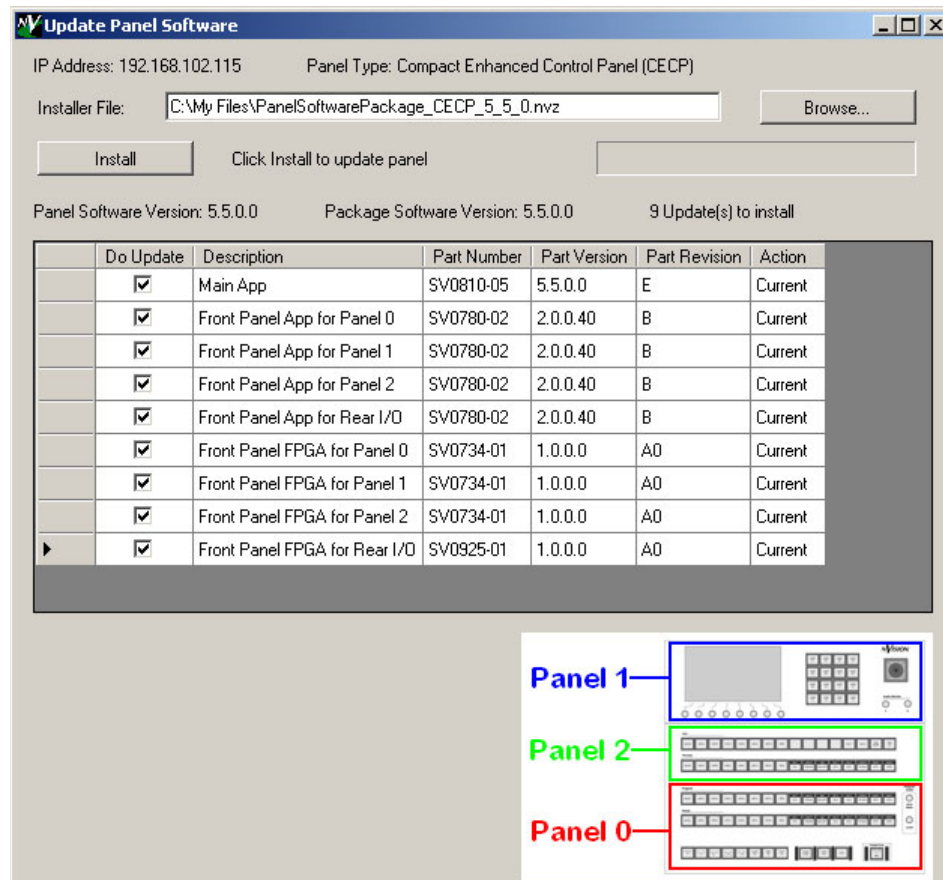

Here also, the update dialogs shows the control panel's IP address, making it evident which panel is being updated. You must browse to find the appropriate .nvz file to upload.

The dialog displays a list of the panel's software and firmware. Each entry in the list has a checkbox specifies whether the software or firmware is to be updated. The list also shows the versions of the software and firmware that would be loaded. The 'Action' column in the list tells you whether the software or firmware needs an update. In that column, the term 'Current' indicates that the software or firmware does not need an update. The term 'Update' indicates that the software or firmware does need an update.

▲ Software and firmware that require updating are also indicated by red highlighting.

When you have selected the software or firmware, click 'Install' and wait for the configuration editor to indicate successful completion. This might take several minutes. Be patient. A progress

bar gives you some indication of progress, but do not consider the update finished until you get a successful completion message.

(This dialog gives you an estimate of the time the update requires.)

### All Cases

When an update completes successfully, the configuration software asks whether you want to restart the panel immediately.

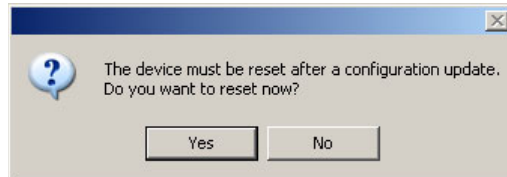

Answer 'Yes' or 'No'. You can also issue an 'Update Config' command later from the control panel's menu system to restart the control panel with the new software. It takes about one second to restart.

### Help Menu

This is the 'Help' menu:

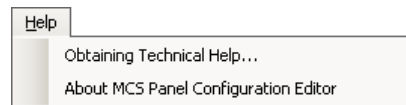

### About MCS Panel Configuration Editor

Click 'About MCS Panel Configuration Editor...' to display the "About MCS Panel Configuration Editor" message:



This window tells you the configuration editor's present version number.

## Obtaining Technical Help

Click 'Obtaining Technical Help...' to display the "Technical Support" window.



## Guidelines

Following are general guidelines for making configuration changes.

### IP Addresses

Hardware control panels are identified by their IP addresses. To add an IP address to the list area, right-click "Panels" at the "root" of the list.



The 'Add Panel' dialog appears:

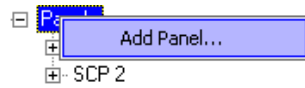

Click 'Add Panel...' The name dialog appears:

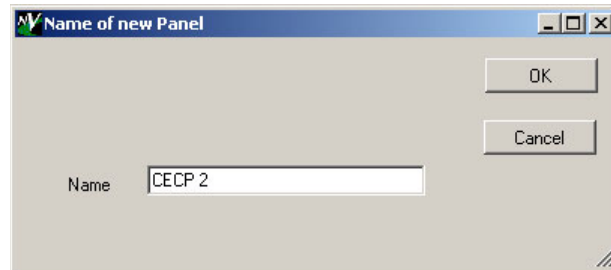

In this dialog, you give the panel a name for use in the list. The name is arbitrary but it is required. Click 'Cancel' if you do not want to continue.

If you click 'OK', the IP address dialog appears:

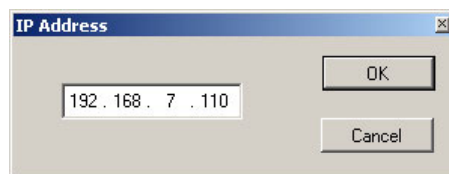

Enter the IP address in the 4 octet fields and click 'OK' or click 'Cancel' if you change your mind.

## Renaming or Deleting

To rename a list entry or delete the entry, right-click the *name* of the entry:

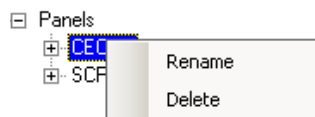

If you choose 'Rename', the rename dialog appears:

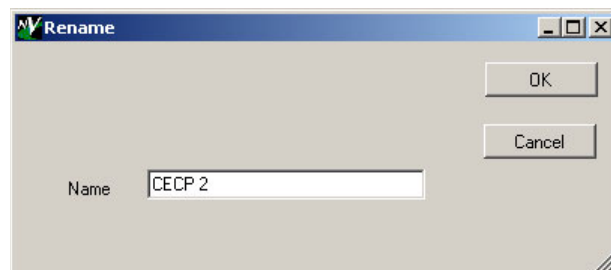

If you choose 'Delete', the configuration editor deletes the entry, with no further dialog.

## Changing an IP Address

To change an IP address in the list, right-click the address: The 'Change' dialog appears:

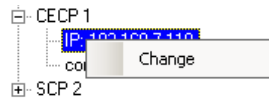

Click the 'Change' command. The IP address dialog appears:

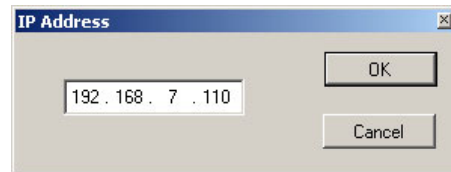

Enter the IP address in the 4 octet fields and click 'OK' or click 'Cancel' if you do not want to change the address.

▲ Changing the IP address in the list **does not** change the IP address of the actual panel. To change the actual IP address requires changing settings at the panel itself.

You cannot of course read from or write to a panel that does not exist. The configuration editor will report an Ethernet error if you attempt it.

List entry names can have up to 255 characters. The names can be what you like. The names have no significance other than to be helpful. Only the IP addresses are significant.

If you need to obtain a hardware control panel's IP address, choose the 'Panel' menu (of the control panel). The menu displayed will tell you the panel's IP address.

You can also use the 'Search for Panels' command from the Tools menu to view a list of panels and their IP addresses.

A hardware control panel has a factory-defined IP address (192.168.7.100 or something similar). For systems with more than one hardware control panel, it is essential to assign a unique IP address to the panel before it is connected to the master control network. Do that at the panel itself using the 'IP Setup' command in its 'Panel' menu.

## Configuration Files

To change the configuration file associated with a panel in the list, right-click the configuration file line for the panel. Choose 'Change File' command:

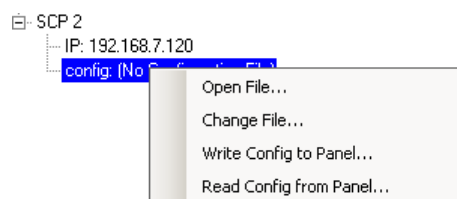

To change *and open* a configuration file, choose 'Open File...'. An Open dialog follows.

The Write Config... and Read Config commands are the same as the File menu commands.

The configuration file named in the panel list is not necessarily the configuration in the panel. The named file is simply the default for that particular panel.

A GUI's IP address is that of the PC on which it runs. You should not enter a GUI's IP address in the panel "tree."

## Operational Overview

The following three points represent typical scenarios for using the configuration editor:

- [New Configuration](#)

- New
- Edit
- Save to file
- Write to panel

- [Modifying an Active Configuration](#)

- Read from panel
- Edit
- Save to file
- Write to panel

- [Modifying a Stored Configuration](#)

- Open file
- Edit
- Save to file
- Write to panel (optionally)

- ▲ Note: A control panel always has a configuration. Initially it is an empty configuration. (If it does not have a configuration, it is probably inoperable.)

## New Configuration

Although you can create new configuration files, we recommend that you always read a configuration from a control panel first before making a new configuration for that panel.

To create a new configuration file and write it to a control panel:

- 1 Click 'File > New' to start a new configuration.
- 2 Go through all the tabbed pages in the work area, making parameter settings as you require.
- 3 When you have finished making all your intended settings, save the configuration file by clicking 'File > Save' or 'File > Save As'.

For a new configuration, a "Save As" dialog appears:

In the dialog, name the file and click 'OK'. Browse if you need to select a folder for the file. The default configuration file folder is:

```
C:\Program Files\Miranda\Master Control\config\
```

- 4 Optionally, write the configuration to the panel or panels.

## Modifying an Active Configuration

Follow these basic steps to modify an *active* configuration file and write it to a control panel:

- 1 Select the IP address of the panel you want to modify. Click 'File > Read Config from Panel..' to obtain the current configuration from the selected control panel. The "Read Config from Panel" dialog will ask for a configuration file name. Select a folder and enter the file name. Double-check that you have the right IP address. The default folder is:

```
C:\Program Files\Miranda\Master Control\config\
```

Click 'OK' to read the configuration data from the control panel to the file.

- 2 Go through the tabbed pages in the work area, making parameter changes as you require.
- 3 When you have finished changing all your intended settings, save the configuration file by clicking 'File>Save' or 'File>Save As'.
- 4 Optionally, write the configuration to the panel or panels.

### Modifying a Stored Configuration

Follow these basic steps to modify an *existing* configuration file and, optionally, write it to a control panel:

- 1 Right-click the pathname of a panel in the panel list. Choose 'Open File' to open the file.  
Or, click 'File>Open'. In the "Open" dialog, select a folder and choose a configuration file. The default folder is:  
C:\Program Files\Miranda\Master Control\config\  
Click 'OK' to read the file.
- 2 Go through the tabbed pages in the work area, making parameter changes as you require.
- 3 When you have finished changing all your intended settings, save the configuration file by clicking 'File>Save' or 'File>Save As'.
- 4 Optionally, write the configuration to the panel or panels.

### Updating a Panel

- 1 If you want to update a hardware panel with the modified configuration...  
Send the configuration file to the panel by clicking 'File>Write Config to Panel...!' or by right-clicking the configuration file's pathname in the panel list and choosing 'Write Config to Panel...!'  
In the 'Write Config to Panel' dialog, be sure that the IP address identifies the control panel you want to update. Double-check that the configuration file name displayed is the correct file.
- 2 Click 'OK' to transfer the file to the control panel. The configuration editor will ask you whether you want to restart the panel. If you do, click 'Yes'. If you say 'No', you can also restart the panel later, at the panel itself.  
If you are configuring a GUI, copy the configuration file to the folder in which the GUI program (MasterGUI.exe) resides and restart the GUI. It will launch with the new configuration. The configuration file must be named "MasterGUI.uicfg" to be recognized.

# 5 Operation (for MCEs and MCPMs)

Chapter 5 provides information about using the tabbed configuration pages—for panels when they are controlling MCEs and MCPMs—in the configuration editor’s work area.

## Topics

|   |     |
|---|-----|
| <a href="#">New Configurations</a> .....      | 103 |
| <a href="#">General</a> .....                 | 105 |
| <a href="#">Channel Selection List</a> .....  | 106 |
| <a href="#">User Button Layout</a> .....      | 109 |
| <a href="#">Bottom Row Layout</a> .....       | 110 |
| <a href="#">Logging Settings</a> .....        | 111 |
| <a href="#">NV9000 Settings</a> .....         | 112 |
| <a href="#">Advanced</a> .....                | 113 |
| <a href="#">Button Assignments</a> .....      | 120 |
| <a href="#">User Menu Lists</a> .....         | 122 |
| <a href="#">Menu Layouts</a> .....            | 124 |
| <a href="#">Aux Delegates</a> .....           | 125 |
| <a href="#">Audio Monitoring Layout</a> ..... | 127 |
| <a href="#">Audio Macros</a> .....            | 129 |

(See chapter 7 on page 157 for information about configuring panels for use with Imagestore 750s.)

## New Configurations

When you create a new configuration, the configuration editor asks you for a control panel type:

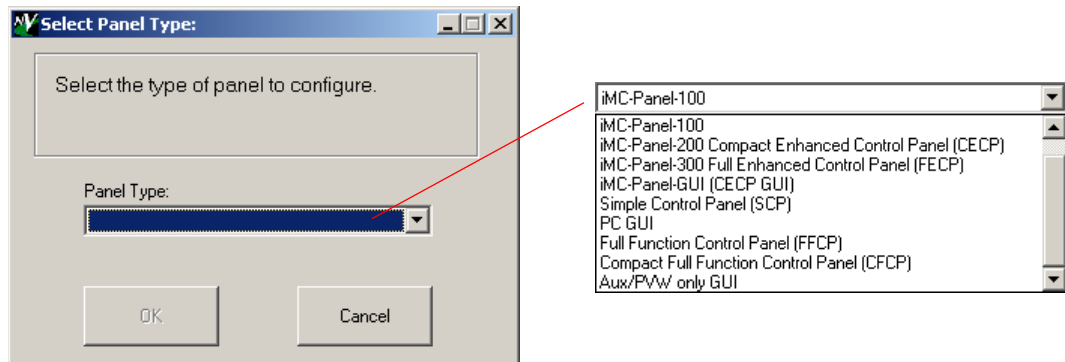

There are 8 choices in the drop-down menu. After you choose a control panel class, the configuration is locked to that control panel class. (Some classes include more than one panel type. All the panels in a class can share configuration files.)

These are the classes and the panel types for each class:

| Class   | Panel Types                  |
|---|------------------------------|
| Simple Control Panel (SCP) <sup>a</sup>                 | SCP                          |
| iMC-Panel-100   | iMC-Panel-100                |
| iMC-Panel-200 Compact Enhanced Control Panel (CECP)     | iMC-Panel-200, CECP, CECP M1 |
| iMC-Panel-300 Full Enhanced Control Panel (FECF)        | iMC-Panel-300, FECF          |
| iMC-Panel-GUI (CECP GUI)                                | iMC-Panel-GUI, CECP GUI      |
| PC GUI <sup>a</sup>                                     | PC GUI                       |
| Full-function control panel (FFCP) <sup>a</sup>         | FFCP                         |
| Compact full-function control panel (CFCP) <sup>a</sup> | CFCP                         |
| Aux/PVW only GUI  | Aux/Preview GUI              |

a. These are obsolete panels.

You will see a different set of configuration pages depending on the type of control panel you want to configure. Configuration pages applicable to MCEs and MCPMs, shared by most panels types, include:

- |  |                                    |                                   |
|--|------------------------------------|-----------------------------------|
| <a href="#">General</a>                | <a href="#">User Button Layout</a> | <a href="#">Bottom Row Layout</a> |
| <a href="#">Channel Selection List</a> | <a href="#">Logging Settings</a>   | <a href="#">NV9000 Settings</a>   |
| <a href="#">Advanced</a>               | <a href="#">Button Assignments</a> | <a href="#">Aux Delegates</a>     |

Configuration pages applicable to the Imagestore 750 include:

- |  |                                    |   |
|--|------------------------------------|---|
| <a href="#">General</a>                | <a href="#">User Button Layout</a> | <a href="#">Bottom Row Layout</a>       |
| <a href="#">Channel Selection List</a> | <a href="#">Logging Settings</a>   | <a href="#">NV9000 Settings</a>         |
| <a href="#">Advanced</a>               | <a href="#">Button Assignments</a> | <a href="#">Audio Monitoring Layout</a> |
| <a href="#">Aux Row</a>                | <a href="#">Preview/User Row</a>   | <a href="#">Monitor Wall</a>            |

The CFCP, SCP, CECP, CECP M1, CECP GUI, FECF, iMC-Panel-100, iMC-Panel-200, iMC-Panel-GUI, iMC-Panel-300, and Aux/Preview GUI allow “virtual button bank selection,” and reordering of video effect and audio over buttons. These panels have a [Button Assignments](#) page in addition to other configuration pages.

The FECF and iMC-Panel-300 do not allow “bank selection,” but do allow reordering of video effect and audio over buttons (in the [Button Assignments](#) page). The FFCF does not allow bank selection and does not allow reordering of video effect and audio over buttons.

The SCP is unique because its menu is implemented on buttons. Instead of ‘User Button Layout’ and ‘Bottom Row Layout’ configuration pages, it has [User Menu Lists](#) and [Menu Layouts](#) configuration pages.

The CECP, CECP M1, CECP GUI, iMC-Panel-100, iMC-Panel-200, iMC-Panel-300, iMC-Panel-GUI, and Aux/Preview GUI have aux buttons, so the configuration editor provides an [Aux Delegates](#) page for these panels. (See page 125.)

The CECP, CECP M1, CECP GUI, FECF, iMC-Panel-100, iMC-Panel-200, iMC-Panel-300, iMC-Panel-GUI, and Aux/Preview GUI support audio macros, so the configuration editor provides an [Audio Macros](#) page for these panels. (See page 129.)

The FECF and the iMC-Panel-300 have a configurable monitor/meter section, so the configuration editor provides an [Audio Monitoring Layout](#) page. (See page 127.)

The content of a configuration page varies for different panels. For instance, the layout of the “bottom row” of an iMC-Panel-300 is different from the “bottom row” of an iMC-Panel-200. Certain panels (iMC-Panel-100, iMC-Panel-200, iMC-Panel-GUI, and iMC-Panel-300) can control Imagestore 750s as well as MCEs and MCPMs. The configuration pages for these panels are divided into two sets. You can select the set with which to work in the ‘General’ page. The configuration pages are different in each set. Sometimes the difference is subtle and sometimes the difference is great.

This chapter addresses the pages for panels that control MCEs and MCPMs. Chapter 7 addresses the pages for Imagestore 750s.

## General

The ‘General’ page allows you to enter (or change) the control panel’s name:

The image shows a screenshot of the 'General' configuration page in the MCS Panel Configuration Editor. The page has a tab labeled 'General' at the top left. Below the tab, there is a text input field for 'Panel Name' containing the text 'iMC-300'. Below that, the 'Panel Type' is displayed as 'iMC-Panel-300 Full Enhanced Control Panel (FECP)'. At the bottom, there is a section titled 'Master Control type' with two radio button options: 'MCE / MCPM' (which is selected) and 'Imagestore'.

Fig. 5-1: General Page (Sample)

We recommend that you use the default name, but it is possible for you to enter a name of your choosing. Do not use a space in the panel name. The configuration editor will accept it, but the space might cause problems on your master control network.

For certain panels (iMC-Panel-100, iMC-Panel-200, iMC-Panel-GUI, and iMC-Panel-300), you can select the set of configuration pages with which you wish to work. Select either ‘MCE/MCPM’ or ‘Imagestore’. If the panel is to control MCEs, MCPMs, *and* Imagestore 750s, do not neglect one or the other set of configuration pages.

When you choose ‘New’ in the ‘File’ menu, you are asked for a panel type. After you have chosen a panel type, the configuration is “locked” to that panel type. The ‘General’ page reports the panel type you have chosen.

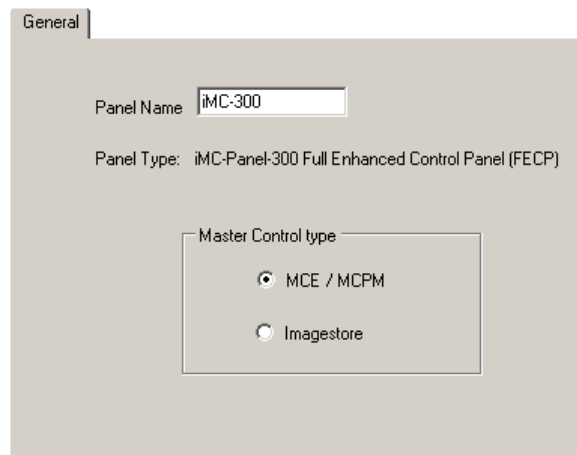
The ‘General’ page appears when you start a new configuration, open an existing configuration, read a configuration from a panel, and, of course, when you click the ‘General’ tab itself.

## Channel Selection List

Use the 'Channel Selection List' page to specify what channels (MCPMs or MCEs) the control panel may access:

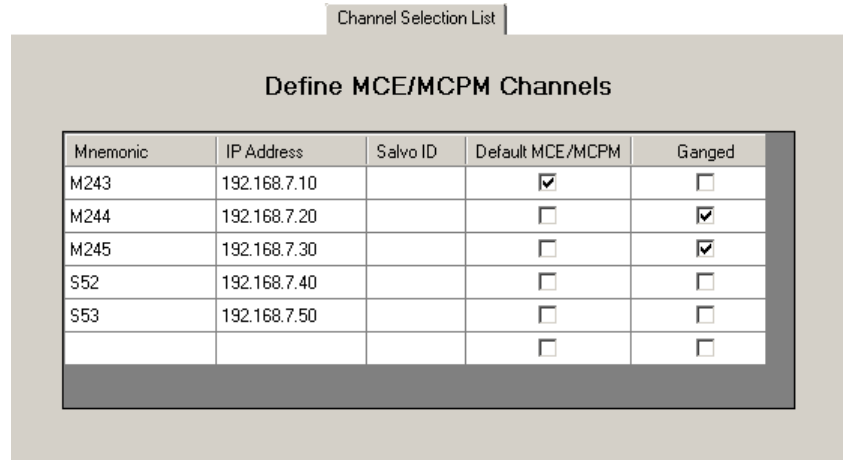

The page for the CECP M1 has an extra field that specifies whether to switch its live levels display to metering input A or metering input B, when the channel is selected:

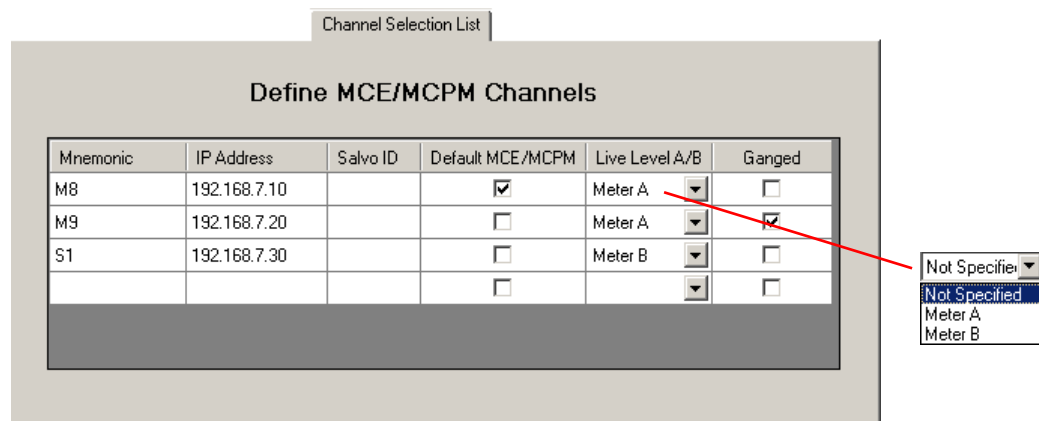

Fig. 5-2: Channel Select List Page (Sample)

The page contains a table of channels. The table uses one row to represent each MCPM or MCE. Each row includes a channel name, the IP address of the channel, and checkbox to indicated whether the table entry is the default channel. The default channel is the one that is selected when the panel restarts.

Note that, if your panel (e.g., a iMC-Panel-200) can control an Imagestore 750, there is a *different* 'Channel Selection List' page for Imagestore 750s. Keep in mind these points:

- 1 IP addresses for *all* of your channels, regardless of type, must be unique.
- 2 A panel may have at most one default channel. If you designate a channel as the default in the MCE/MCPM pages, any default you selected in the Imagestore pages will be cleared. Similarly, if you designate a channel as the default in the Imagestore pages, any default you selected in the MCE/MCPM pages will be cleared.



## Automatic Gang Mode

Each row also includes, at the right, a checkbox that indicates whether the channel is “ganged” with the default channel at startup. These check boxes control what is called *automatic gang mode*. Automatic gang mode is where a set of channels (up to 4) is ganged whenever the default channel is selected. That can occur when the panel starts up, when the operator selects that channel through a panel menu or using a configurable button, when the operator presses a ‘Channel Control’ button, or when automation selects the channel.

Using a ‘Gang Channels’ button, the panel operator can “un-gang” a set of channels at any time or create new and different “gangs” at any time.

When channels are ganged (grouped), one channel is the “main” channel, and other channels in the group are “followers.” What an operator does for the main channel also occurs for the followers.

In the context of the ‘Channel Selection List’ page, if channels are ganged, the “main” channel of the gang is the one checked in the ‘Default MCPM’ column. The followers are those checked in the ‘Ganged’ column.

You can check only one entry in the ‘Default MCPM’ column. You may check up to 3 entries in the ‘Ganged’ column. A channel cannot be checked in both columns. (MCEs are considered MCPMs.)

- ▲ Automatic gang mode is not available for the FFCP, CFCP, or PC GUI. You will not see a ‘Ganged’ column when you are creating configurations for those panels.
- ▲ If channels are ganged, they must all be MCEs and MCPMs. Imagestore 750s cannot be ganged.

## Kaleido X Integration

Kaleido-X integration is enabled or disabled in the [Advanced](#) configuration page. When it is enabled, a channel change can trigger a *re-layout* of the Kaleido-X multi-viewer. Two additional fields appear in the channel list: ‘Kaleido-X Room’ and ‘Kaleido-X layout’:

Channel Selection List

**Define MCE/MCPM Channels**

| Mnemonic | IP Address   | Salvo ID | Default MCE/MCPM                    | Ganged                              | KaleidoX Room | KaleidoX Layout |
|----------|--------------|----------|-------------------------------------|-------------------------------------|---------------|-----------------|
| M243     | 192.168.7.10 |          | <input checked="" type="checkbox"/> | <input type="checkbox"/>            | ROOMX16 ▾     | Layout 02.kg2 ▾ |
| M244     | 192.168.7.20 |          | <input type="checkbox"/>            | <input checked="" type="checkbox"/> | ▾             | ▾               |
| M245     | 192.168.7.30 |          | <input type="checkbox"/>            | <input checked="" type="checkbox"/> | ▾             | ▾               |
| S52      | 192.168.7.40 |          | <input type="checkbox"/>            | <input type="checkbox"/>            | ROOMX16 ▾     | Layout 04.kg2 ▾ |
| S53      | 192.168.7.50 |          | <input type="checkbox"/>            | <input type="checkbox"/>            | ROOMX16 ▾     | Layout 09.kg2 ▾ |
|          |              |          | <input type="checkbox"/>            | <input type="checkbox"/>            |               |                 |

These fields are drop-down lists (unless you are working off-line) in which you may select a “room” and a layout for that room. You can do this for each channel that is to trigger a re-layout when an operator selects it.

## Channel Thumbnails

▲ Thumbnails are available only for the iMC-Panel-100.

If you are editing an iMC-Panel-100 configuration, the 'Channel Selection List' page has an extra column—a 'Bitmap' column:

Channel Selection List

**Define MCE/MCPM Channels**

| Mnemonic ▲ | IP Address      | Salvo ID | Default MCE/MCPM         | Ganged                   | Bitmap                                      |
|------------|-----------------|----------|--------------------------|--------------------------|---|
| MCE 124    | 192.168.102.124 |          | <input type="checkbox"/> | <input type="checkbox"/> | C:\Program Files\Miranda\M...\Jellyfish.bmp |
| MCE 125    | 192.168.102.125 |          | <input type="checkbox"/> | <input type="checkbox"/> | C:\Program Files\Miranda\Mast...\Koala.bmp  |
| MCE 144    | 192.168.102.144 |          | <input type="checkbox"/> | <input type="checkbox"/> | C:\Program Files\Miranda\Master...\lab.bmp  |
| MCE 145    | 192.168.102.145 |          | <input type="checkbox"/> | <input type="checkbox"/> | C:\Program Files\Miranda...Lighthouse.bmp   |
| MCE 146    | 192.168.102.146 |          | <input type="checkbox"/> | <input type="checkbox"/> | C:\Program Files\Miranda\Mas...\Tulips.bmp  |
| MCE 168    | 192.168.102.168 |          | <input type="checkbox"/> | <input type="checkbox"/> | C:\Program Files\Mirand...\Hydrangeas.bmp   |
| SD 121     | 192.168.102.121 |          | <input type="checkbox"/> | <input type="checkbox"/> | C:\Program Files\Mirand...\Pat_the_cat.bmp  |
|            |                 |          | <input type="checkbox"/> | <input type="checkbox"/> |   |

Channel buttons in the top row of the display of an iMC-Panel-100 can show thumbnail images representing the channels. (Channel buttons in positions other than the top row do not show thumbnail images.)

In the 'Bitmap' column, you can specify the pathname of a bitmap (.bmp) file for the channel button. Click the field for a channel to change its pathname. A navigation dialog appears in which you can select a bitmap file.

▲ Although you can select a different file at any time, it is not possible to clear the field once you have entered a pathname.

Channel thumbnails are arbitrary graphics. The graphics files must be 128 × 96 pixels in size, with 24-bit color. The panel editor accepts only .bmp files. It does not accept .jpg, .tif, or .png, or any other format.

(There are 8 buttons in the top row of the display.)

## Usage

You can tab through the entries in the table or click directly on an entry to edit or clear the entry. Entering data in any field of the *bottom* row has the side effect of creating a new empty row.

It is permissible to have entries in this table that do not correspond to actual channels.

Follow these steps to add a channel to this list:

- 1 Enter the IP address of the MCPM or MCE in the IP address column.
- 2 Enter a channel name in the 'Mnemonic' column. That name will appear in the channel selection menu and on buttons of the panel. (Mnemonics are limited to 8 characters.)

3 If you wish to associate an NV9000 salvo with the channel, select it in the Salvo ID column. The selected salvo will execute when the operator selects the channel.

To be able to select a salvo, you must have an NV9000 router control system connected to your master control network. (Refer to the NV9000 documentation for information on salvos.) You must also have checked 'Attach to NV9000' in the [NV9000 Settings](#) page.

If you do not have an NV9000 connected (and attached), you may enter a salvo ID manually in the 'Salvo ID' field. It will help to have a list of salvos and their IDs handy.

After making all the entries you want, take these additional steps:

- 1 Mark one of the channels as the default channel.
- 2 If your panel has the option, and you want to create an automatic channel gang, designate up to 3 of your channels as followers by checking the boxes in the 'Gang' column.

The channels appear in the control panel's channel list—in the 'Channel Select' menu—in the order you enter them here.

If you make a configurable button a 'Channel' button, the configuration editor presents the channel list you define here as choices for the button you are defining. You cannot create a 'channel' button unless the channel is defined on this configuration page.

For the SCP, you create channel buttons as part of the menu system. For other panels, you assign channel buttons to configurable buttons.

## User Button Layout

This is the 'User Button Layout' page:

| Button | Type    | Mnemonic | Channel Selection |
|--------|---------|----------|-------------------|
| 2      | Channel | MCE 125  | 192.168.102.125   |

Fig. 5-3: User Button Layout Page (Sample, iMC-Panel-200)

Select the 'User Button Layout' page to assign functions to the 16 buttons in the configurable button section of the panel. By default, no buttons are assigned.

▲ This configuration page does not apply to the SCP. The configuration editor does not display this page for SCP configurations.

To assign a function to a button, first click the button proxy of your choice, then select a button type in the list on the right.

When you have chosen a button type, assign values to the button fields of the table row at the bottom of the page. The button fields in the table row vary with the button type.

In most cases, you can override the button's default mnemonic.

In the example above, a channel selection button is being configured. The button detail required is the channel's IP address. The mnemonic is automatically obtained from the entries you made in the [Channel Selection List](#) page.

Refer to Chapter 6, [Button Functions \(for MCEs and MCPMs\)](#), for a description of the button types and their associated fields.

▲ You can assign audio macros to buttons if you have defined them in the [Audio Macros](#) page. When macros have been defined, an additional category, 'Audio Macros' appears in the list of button types.

## Bottom Row Layout

This is the 'Bottom Row Layout' page:

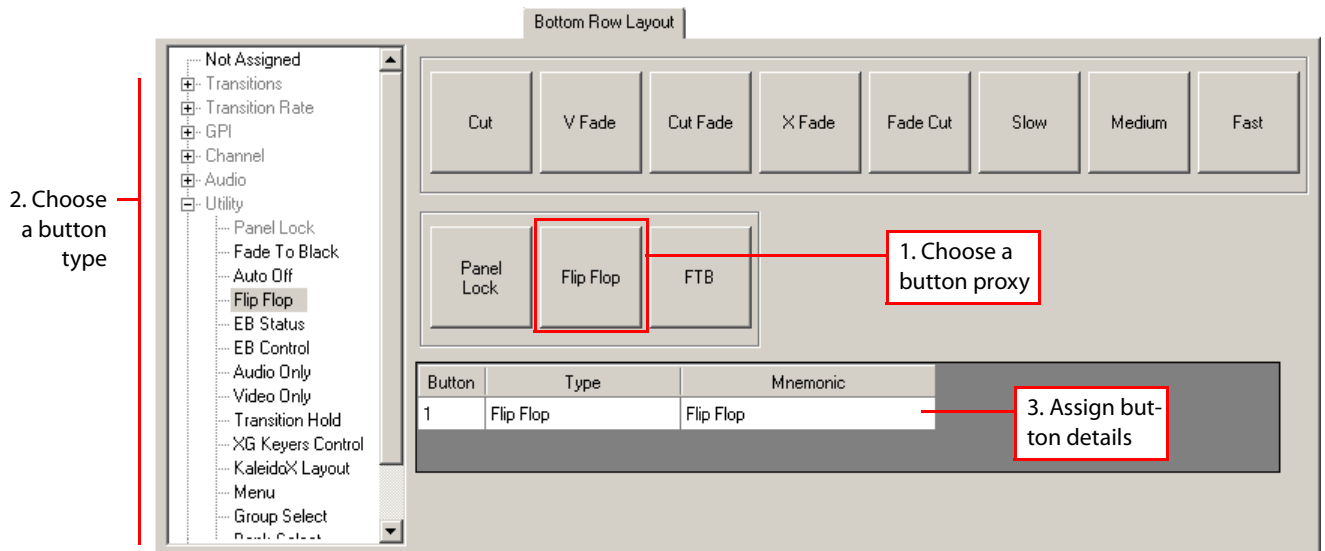

Fig. 5-4: Bottom Row Layout Page (Sample, iMC-Panel-200)

All panels have some number of configurable buttons at the front and left of the panel (or at the bottom and left, in the case of GUIs and the iMC-Panel-100). These are assigned transition control functions and system control functions by convention. The 'Bottom Row' configuration page lets you assign functions to these buttons. The number of buttons in the row differ for different panel models.

To assign a function to a button, first click the button proxy of your choice, then select a button type in the list at the bottom of the page.

When you have chosen a button type, assign values to the button fields of the table row in the middle of the page. The button fields in the table row vary with the button type.

In most cases, you can override the button's default mnemonic.

In the example above, a flip-flop mode button is being configured. This particular button type requires no further detail. Its mnemonic can be whatever you want (up to 24 characters). It should make sense to the panel operator.

Refer to Chapter 6, [Button Functions \(for MCEs and MCPMs\)](#), for a description of the button types and their associated fields.

- ▲ You can assign audio macros to buttons if you have defined them in the [Audio Macros](#) page. When macros have been defined, an additional category, 'Audio Macros' appears in the list of button types.

## Logging Settings

This is the 'Logging Settings' page:

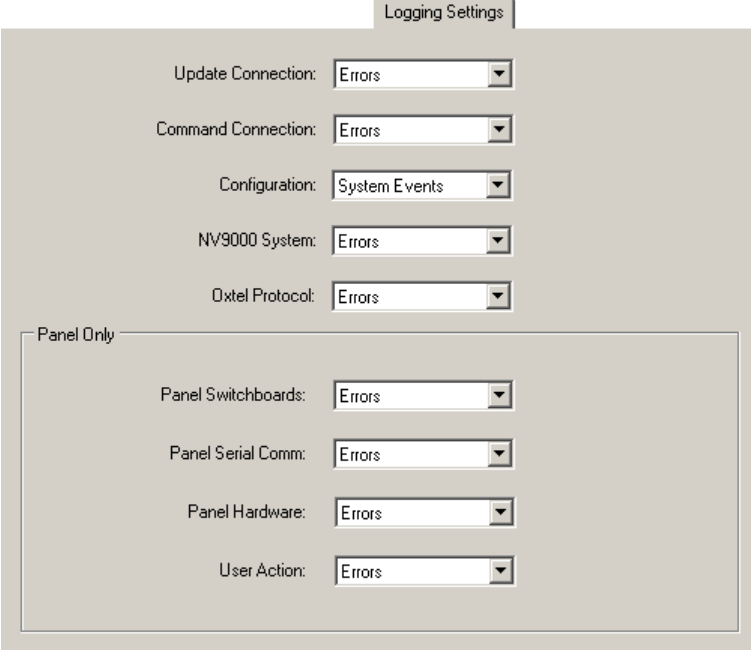

The screenshot shows the 'Logging Settings' page with a title bar. Below the title bar, there are several rows of settings, each with a label and a pull-down menu. The settings are:

- Update Connection: Errors
- Command Connection: Errors
- Configuration: System Events
- NV9000 System: Errors
- Oxtel Protocol: Errors

Below these settings is a section titled 'Panel Only' which contains four more rows of settings, each with a label and a pull-down menu:

- Panel Switchboards: Errors
- Panel Serial Comm: Errors
- Panel Hardware: Errors
- User Action: Errors

*Fig. 5-5: Logging Settings Page (Sample)*

Use this page to set the level of event reporting for several event classes. The levels for each class are the same and are selectable through pull-down lists.

There are 7 levels of reporting:

|               |   |
|---------------|---|
| None          | No error logging is performed.  |
| Errors        | Only critical system errors are logged.   |
| Warnings      | Only warnings and errors are logged.  |
| System events | The activities in the 2 previous levels, plus system events.  |
| Transactions  | The activities in the 3 previous levels, plus a record of all messages between all system components. |
| All events    | All system activity.  |
| Debug         | Information about errors. (Use this option under Miranda direction.)                                  |

The event log is kept within the panel. To examine the log, choose 'Read Log from Panel...' from the 'Tools' menu. In the dialog that follows, save the log in your PC's file system. The log is a text file that you can open in Windows NotePad or a similar program.

For the GUI, the log is kept in a hidden temporary file. To retrieve the log, first save the log from the GUI. The resulting file is always C:\log.txt. Copy that file to some other location and open it with NotePad, Word, or a similar application.

## NV9000 Settings

This is the 'NV9000 Settings' page:

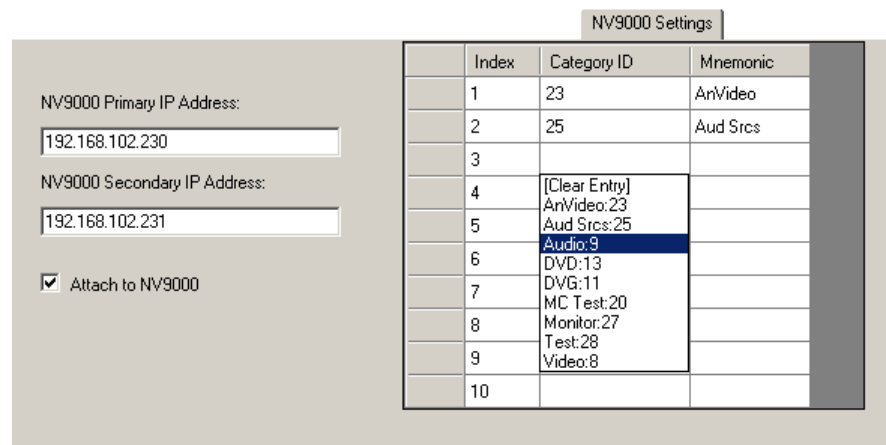

Fig. 5-6: NV9000 Settings Page (Sample)

- ▲ This page is easier to use if you have an NV9000 control system connected to your master control system at the time of configuration.

The purpose of this page is to allow you to specify the router categories a panel operator may choose when performing "router pre-select." It also creates the ordering of those categories.

Generally, a panel operator is presented with a 10-key pad on the touchscreen or menu area:

CFCP, FFCP, PC GUI

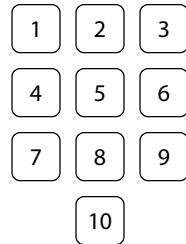

iMC-Panel-100, iMC-Panel-200, iMC-Panel-300, iMC-Panel-GUI, and others

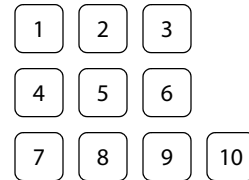

Any of the 10 keys can represent a router category. The operator presses one of the keys to select a category and then presses keys on a numeric keypad to enter a device index within the category.

An *SCP* operator is presented, in the *SCP*'s menu system, with a scrollable list (of up to 10 router categories). The operator chooses one of the categories after which a device list appears. The operator scrolls through that list to select a device within the category.

Follow these guidelines to specify the router categories:

- 1 If you have a redundant NV9000 system, enter the IP address of its primary controller and its secondary controller. If you have a stand-alone system, specify just the IP address of its primary system controller.

If your NV9000 system supports virtual IP addresses, we recommend that you enter the virtual IP address in the primary controller field.

- 2 Check the 'Attach to NV9000' checkbox. If you do not, or if your NV9000 system is unavailable, the configuration editor cannot recognize the NV9000's categories and you must enter category IDs numerically.

Having the NV9000 connected allows you to see the category mnemonics and the database IDs for the categories.

- ▲ You must check this option if you want to view NV9000 mnemonics when you are configuring salvo buttons or channels that execute a salvo when the channel becomes active.

- 3 Click one of the 'Category ID' fields in the table to the right. If the NV9000 is attached, a drop-down menu appears. Entries in the drop-down menu include category names and category IDs. Choose one of the entries. Note that '[Clear Entry]' allows you to remove a category from the table.

After you choose an entry, the category's database ID appears in the 'Category ID' column and the category's mnemonic appears in the 'Mnemonic' column. (The mnemonic appears only if the NV9000 is attached.)

- 4 Repeat step 3 for other categories. The configuration editor allows up to 10 categories.

Please note: the configuration editor does **not** have any knowledge of the devices in the categories. Those devices are discovered dynamically during master control operation.

- ▲ Note that the 'NV9000 Settings' page for Imagestore 750s is different. The Imagestore 750 does not perform router preselect and does not use NV9000 categories.

## Advanced

The 'Advanced' page configures some of the more obscure panel features.

(The 'Advanced' pages for different panels are different, but have common elements. These elements are described, starting on page 117.)

This is an example of the 'Advanced' page (for the SCP, a legacy panel):

The screenshot shows the 'Advanced' configuration page for the SCP panel. At the top, there is a tab labeled 'Advanced'. Below it, there is a section titled 'Kaleido-X integration' with the following text: 'The panel can be integrated with a Kaleido-X. User buttons on the panel can recall monitor wall layouts, or the layout recall can be associated with a channel change.' Below this text is a text box for 'Kaleido-X IP address' containing '192 . 168 . 102 . 54' and a checkbox labeled 'Attach to Kaleido-X' which is unchecked. To the left of the Kaleido-X section, there is a checkbox labeled 'Start in Flip-Flop Mode' which is unchecked. Below these are several color selection dropdown menus: 'PGM selected source color' (Normal), 'PGM unselected source color' (Normal), 'PST selected source color' (Normal), 'PST unselected source color' (Normal), and 'Automation Off button color' (Normal).

This is the 'Advanced' page for the CECP, FECP, iMC-Panel-200, and iMC-Panel-300:

The screenshot shows the 'Advanced' configuration page for CECP, FECP, iMC-Panel-200, and iMC-Panel-300 panels. At the top, there is a tab labeled 'Advanced'. Below it, there are two main sections. The left section is titled 'Enable Automatic Navigation to Menus' and contains a list of checkboxes: 'Key 1', 'Logo A', 'Squeeze', 'Key 2', 'Key 3', 'Logo B', and 'XG Keyer Layers'. Below this list are checkboxes for 'Enable global Source Groups' (unchecked) and 'Start in Flip-Flop Mode' (unchecked). The right section is titled 'Kaleido-X integration' and contains the same text as the first screenshot: 'The panel can be integrated with a Kaleido-X. User buttons on the panel can recall monitor wall layouts, or the layout recall can be associated with a channel change.' Below this text is a text box for 'Kaleido-X IP address' containing '192 . 168 . 102 . 54' and a checkbox labeled 'Attach to Kaleido-X' which is unchecked. Below the Kaleido-X section, there is a section titled 'Always Show Source' with a dropdown menu for 'Always Show Source Number' set to '1' and another dropdown menu for 'Always Follow Bus' set to 'Program'. Below these are several color selection dropdown menus: 'PGM selected source color' (Normal), 'PGM unselected source color' (Normal), 'PST selected source color' (Normal), 'PST unselected source color' (Normal), and 'Automation Off button color' (Normal). Additionally, there is a 'Panel LCD Brightness' slider set to '155' and a 'Menu password' text box.

Because these panels have a large LCD for menus, there is a control to set the LCD brightness.



The Aux/Preview GUI, CECP GUI, iMC-Panel-GUI, and iMC-Panel-100 are similar but **do not** have an LCD field and **do** have a 'Hide Mouse Cursor' field.

Advanced

Enable Automatic Navigation to Menus

- Key 1
- Logo A
- Squeeze
- Key 2
- Key 3
- Logo B
- XG Keyer Layers

Kaleido-X integration

The panel can be integrated with a Kaleido-X. User buttons on the panel can recall monitor wall layouts, or the layout recall can be associated with a channel change.

Kaleido-X IP address: 192 . 168 . 102 . 54

Attach to Kaleido-X

Enable global Source Groups

Start in Flip-Flop Mode

Enable Always Show Source

Always Show Source

Always Show Source Number 1

Always Follow Bus Program

Hide mouse cursor

Menu password

PGM selected source color Normal

PGM unselected source color Normal

PST selected source color Normal

PST unselected source color Normal

Automation Off button color Normal

The mouse cursor is disabled by default for the iMC-Panel-100, but enabled by default for the GUIs.

The Aux/Preview GUI has no flip-flop mode and therefore the page has no flip-flop mode check box.

The CECP M1 is like the CECP and the iMC-Panel-200, but has additional metering options:

The CECP M1 has two metering inputs, A and B. In this page, you can specify whether switching to metering input A triggers GPI output 1 and whether metering input B GPI output 2. If you leave the options unchecked, the metering inputs do not trigger any GPI output.

Metering input can be switched by a channel change or by a function button.

This is the 'Advanced Settings' page for older hardware control panels (FFCP, CFCP, PC GUI):

(The page for the PC GUI does not have the panel brightness field.)

## Enable Automatic Navigation to Menus

All panels except the SCP can be configured so that when the operator presses a video effect or XG keyer layer button on the preset bus or the program bus, the associated effect settings menu appears on the panel's touchscreen.

Check any of the check boxes to enable automatic navigation for that effect. Clear the check box to disable automatic navigation.

- ▲ The XG keyer layer check box is always present in the panel configuration editor for iMC-Panel-300s, iMC-Panel-200s, iMC-Panel-100s, and iMC-Panel-GUIs. However, actual XG keyer layers are available only when one of these panels is controlling an MCE with Intuition XG enabled.
- ▲ The XG keyer layer check box applies to all XG layer buttons.

## Kaleido-X Integration

Master control can be integrated with a Kaleido-X multi-viewer (or monitor wall) in such a way that master control can trigger a Kaleido-X *re-layout*. The Kaleido system defines rooms (in which a multi-viewer exists) and layouts (the organization of views on the multi-viewer) for each room.

Panel operators can have available buttons that trigger multi-viewer re-layout. A channel change can also trigger a multi-viewer re-layout.

The option in the Advanced configuration page (1) enables Kaleido-X integration and (2) specifies the IP address of the Kaleido-X multi-viewer.

When Kaleido-X integration is enabled, the 'Channel Selection List' page shows two additional fields: 'Kaleido-X Room' and 'Kaleido-X Layout'. You can specify the Kaleido-X room and layout for the that will take effect when the panel switches to that channel. See [Channel Selection List](#) on page 106.

When Kaleido-X integration is enabled, a 'Kaleido-X Layout' button shows drop-down lists for its 'Kaleido-X Room' and 'Kaleido-X Layout' fields. See [Kaleido-X Layout](#) on page 143.

## Start in Flip-Flop Mode

In flip-flop mode, the content of the preset and program buses swap after a transition. In flip-only mode, the preset bus remains the way it was — except for video effects that were configured (in the MCPM configuration) to clear the preset bus after a transition.

Check the check box to select flip-flop mode as the default; clear the box to select flip-only mode as the default. If you also configure a panel button to toggle flip-flop modes, the operator can switch modes. Otherwise the panel remains in the mode in which it powered up.

- ▲ The Aux/Preview GUI does not support flip-flop mode because it does not support transitions of any kind.

## Panel LCD Brightness

Enter a value from 0 to 255 in the brightness field. A value of 255 results in full brightness.

This of course applies only to the panels with LCDs: the iMC-Panel-100, iMC-Panel-200, iMC-Panel-300, CFCP, or FFCP. An operator can change the brightness value from 40 to 255. For the SCP and GUIs, the LCD brightness field is absent.

## PGM Selected Source Color

With this option, you can designate the color displayed on *selected* (high-tally) source buttons of the *program* bus. These are your choices:

- 'Normal' (green).
- 'Alternate White'.
- 'Alternate Red'.
- 'Alternate Yellow'.

▲ Be aware that red is also the color used to indicate *errors* such as LOS or a non-synchronous source.

## PGM Unselected Source Color

With this option, you can designate the color displayed on *unselected* (low-tally) source buttons of the *program* bus. These are your choices:

- 'Normal' (green).
- 'Alternate White'.
- 'Alternate Red'.
- 'Alternate Yellow'.

## PST Selected Source Color

With this option, you can designate the color displayed on *selected* (high-tally) source buttons of the *preset* bus. These are your choices:

- 'Normal' (green).
- 'Alternate White'.
- 'Alternate Red'.
- 'Alternate Yellow'.

## PST Unselected Source Color

With this option, you can designate the color displayed on *unselected* (low-tally) source buttons of the *preset* bus. These are your choices:

- 'Normal' (green).
- 'Alternate White'.
- 'Alternate Red'.
- 'Alternate Yellow'.

## 'Automation Off' Button Color

With this option, you can designate how the 'Automation Off' button functions. These are your choices:

- 'Normal' (low-tally green when automation is on, high-tally red when automation is off).
- 'Reverse' (high-tally red when automation is on, low-tally green when automation is off).

The 'Reverse' option is essentially a warning that automation is on and operators must exercise caution **not** to use the panel.

## Hide Mouse Cursor

This option is available for GUIs and for the iMC-Panel-100.

A GUI can be installed on a PC that has a touchscreen. The iMC-Panel-100 can be used with a touchscreen or with an ordinary VGA monitor.

If your panel has a touchscreen, a cursor driven by a mouse is superfluous. You will probably want to disable the display of the cursor on such displays. For those panels, check the 'Hide Mouse Cursor' option. If your display is an ordinary monitor, leave the option unchecked.

## Enable Global Source Groups

If you check the 'Enable Global Source Groups' option, when the panel operator selects a source group, all panels controlling the same MCE switch to that source group.

If you leave the option unchecked, the switch stays local to the panel at which the group selection was made.

For more information, see the [Group Select](#) button on page 143.

Source groups for MCEs are defined in MasterConfig.

## Enable 'Always Show Source'

If you enable this option by checking the checkbox, additional options appear:

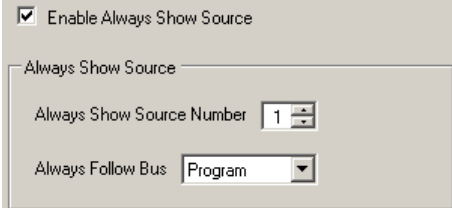

The image shows a configuration window with a checked checkbox labeled "Enable Always Show Source". Below this checkbox is a sub-section titled "Always Show Source" which contains two controls: a spinner box for "Always Show Source Number" set to the value "1", and a dropdown menu for "Always Follow Bus" with "Program" selected.

When this option is enabled, automation when selecting a source that is not present on one of the panel's main source buttons will use one of the buttons to "show the source."

You can specify the button to use for this by scrolling through the numbers in the 'Always Show Source Number' list.

Specify either 'Program' or 'Preset' in the 'Always Follow Bus' drop-down menu. A typical configuration would have 'Preset' selected.

## Menu Password

If you enter a numerical value in this field, operators must enter a this number as password before they can enter and use menus on the panel.

Note that the value must be numerical. Only digits are accepted in the field.

## Button Assignments

▲ The configuration editor does not display this page for PC GUI or FFCP configurations.

▲ The 'Button Assignments' pages for panels controlling Imagestore 750s are different.

This is the 'Button Assignments' page as it might appear for a iMC-Panel-200:

| Button    | Function         | Bank A Source | Bank B Source |
|-----------|------------------|---------------|---------------|
| Button 1  | Main Source      | 1             | 5             |
| Button 2  | Main Source      | 2             | 6             |
| Button 3  | Main Source      | 3             | 7             |
| Button 4  | Main Source      | 4             | 8             |
| Button 5  | XG keyer layer 1 |               |               |
| Button 6  | XG keyer layer 2 |               |               |
| Button 7  | XG keyer layer 3 |               |               |
| Button 8  | XG keyer layer 4 |               |               |
| Button 9  | Key 1            |               |               |
| Button 10 | Logo A           |               |               |
| Button 11 | Sqz              |               |               |
| Button 12 | Key 2            |               |               |
| Button 13 | Key 3            |               |               |
| Button 14 | Logo B           |               |               |
| Button 15 | Over 1           |               |               |
| Button 16 | Over 2           |               |               |

Fig. 5-7: Button Assignments Page (Sample, iMC-Panel-200)

Most panels allow a variable number of main source buttons, video effect buttons, and audio over buttons. This is the page in which to specify the number of such buttons and to distribute those button functions on the program bus, preset bus, and the preview bus (if present on the panel).

The number of main source buttons allowed varies with the panel:

|               |      |               |      |                 |      |
|---------------|------|---------------|------|-----------------|------|
| CFCP          | 8–16 | FFCP          | 16   | PC GUI          | 16   |
| CECP, CECP M1 | 0–16 | FECP          | 0–24 | CECP GUI        | 0–16 |
| iMC-Panel-200 | 0–16 | iMC-Panel-300 | 0–24 | iMC-Panel-GUI   | 0–16 |
| iMC-Panel-100 | 0–16 | SCP           | 0–16 | Aux/Preview GUI | 0–16 |

On the CFCP, the leftmost 8 preset/program buttons are always main source buttons. The 8 layer buttons to the right may vary. The FFCP has 16 fixed main source buttons and 8 fixed layer buttons.

Up to 6 video effects and 2 audio overs can be defined, subject to the number of main source buttons. The newer panels also allow up to 4 XG keyer layer buttons in addition to the other video effects and audio overs. (XG keyer layer buttons are disabled during operation unless the panel is controlling an MCE that has been configured for integration with an Intuition XG processor.)

Layer buttons that are not used for video effects, XG keyer layers, or audio overs may be used as main source buttons. However, all main sources must be contiguous on the left side of the button rows. All layers are to the right of the main sources but they need not be contiguous and they need not be in any particular order.

However, the effects always execute in the order defined by the MCPM or MCE:

Keyer 1, Logo A, Squeeze, Keyer 2, Keyer 3, Logo B

Keyer 1, Keyer 2, Keyer 3, Logo [for Mixer/Keyers]

Audio overs are mutually exclusive and not ordered.

XG keys are handled by the MCE's keyers. If the Intuition XG processor has two key channels then the MCE is constrained to use keyers 2 and 3. If the Intuition XG processor has one key channel then it may be assigned to any of the 3 keyers.

▲ An Intuition XG processor has one or two channels. Each channel provides up to 4 layers. The layers are selected or deselected with XG layer buttons.

Your panel need not have any video effect, audio over, or XG layer buttons. The default setting, however, includes all video effects and overs, and no XG layers. You might want to remove an effect or over from the button rows if you do not use it.

## Main Source Button Qty

The FFCP and PC GUI have 16 fixed main source buttons and for these, the concept of "virtual main source buttons" does not apply.

All other panels support up to 16 "virtual" main source buttons. Some panels might have fewer than 16 *physical* main source buttons. Except for the iMC-Panel-300 and FFCP, the virtual buttons belong to 2 banks, A and B, that can be assigned to physical main source buttons when the operator presses a bank select button. The iMC-Panel-300 and FFCP do not have a bank select function.

To change the number of physical main source buttons, check the 'Enable' box in the 'Main Source Button Qty' section. Then enter the number of main sources in the scroll box in that section. You can use the tiny scroll arrows to select the number desired or you can type it directly.

When you have chosen the number of main sources, you can uncheck the 'Enable' box to prevent accidentally changes.

## The Button Table

The button table has 16 or 24 rows representing the 16 or 24 buttons of the preset bus, program bus, and preview bus (if present on the panel). The aux bus (if present on the panel) has the same source buttons as the other buses, but has no video effect, audio over, or XG keyer layer buttons.

Follow these guidelines to define the button table.

- 1 Before changing the button definitions in the button table, choose the number of physical main sources you will be using in this configuration.
- 2 Double-click entries in the Bank B or the Bank A column and re-enter the values there so that the physical buttons get the virtual buttons of your choice when the operator selects the bank.

▲ The iMC-Panel-300 does not support bank selection. The 'Button Assignments' page for iMC-Panel-300s does not have columns labeled Bank A or Bank B.

You can change any entry in the columns labeled 'Bank A Src' or 'Bank B Src'. The entries in either column may be blank. The only stipulation is that you cannot duplicate entries in a single column.

Column B is allowed to duplicate some of the virtual main source buttons in column A. This allows you to keep the same source (perhaps a router pre-select source) always present on the same physical button.

- 3 Assign or unassign any of the video effects, audio overs, and XG keyer layers (if available), on the buttons below the main sources in the button table.

Double-click the 'Function' column field for the effect's table row. A drop-down list appears. The first item in the pull-down list is blank. Choose that blank or choose '[Clear Entry]' to remove an effect assigned to that particular physical button. Choose any of the other entries to assign that effect or over to the physical button.

There can be no duplication. If you want to assign an effect to a button and it is already assigned to another button, you must first remove the assignment from the other button.

## User Menu Lists

- ▲ This configuration page applies *only* to the SCP. The configuration editor does not display this page for other panel types.

This is the 'User Menu Lists' configuration page:

|   | Menu ID | Menu Name          | Menu Mnemonic |
|---|---------|--------------------|---------------|
|   | 4001    | Trans Menu         | Trans Menu    |
|   | 4002    | Break Away         | Break Away    |
|   | 4003    | Video Effects      | Video Effects |
|   | 4004    | User Buttons       | User Buttons  |
|   | 4005    | Other              | Other         |
|   | 4006    | Source Select Menu | Source Select |
|   | 4007    | Audio              | Audio         |
|   | 4008    | Audio Levels Menu  | Audio Levels  |
| * |         |                    |               |

Fig. 5-8: User Menu Lists Page (Sample, SCP)

This configuration page is used in conjunction with the 'Menu Layouts' configuration page. To define a menu layout, you must first create an entry for the menu on this page.



The page illustrated in Figure 5-8 is from the default SCP configuration that ships with the master control software. If you start with a new configuration, the menu list on this page will be empty:

|   | Menu ID | Menu Name | Menu Mnemonic |
|---|---------|-----------|---------------|
| * |         |           |               |

The SCP provides a hierarchical (tree-structured) menu system that is, for the most part, customer-definable. The menu area of the SCP has 8 buttons. The leftmost button in the SCP's menu area is a special-purpose button. It either (1) takes the operator back to the main menu or (2) at the main menu level, takes the operator to the built-in (non-configurable) 'Panel' menu. Each of the rightmost 7 buttons can be assigned one of many functions. Some buttons can be navigation buttons that take the operator to other menus.

In addition to the menus you can define, there is always a configurable "top level" (or "main") menu. There are several built-in menus (such as the 'Panel' menu) but these are not configurable.

The process of creating or defining a tree of menus for the SCP warrants careful thought—with particular attention to how the operator will navigate to different functions. The default SCP configuration—available on the software and documentation CD (SB0243)—shows how the menu hierarchy can be put to use.

To add a menu to the menu list, click on an empty 'Menu Name' or 'Menu Mnemonic' field and type a name or a mnemonic. Each entry must have both a name and a mnemonic. The mnemonic is what the user sees on a menu button. The menu name can be the same as or different from the mnemonic.

When you type anything in the last row of the table, the configuration editor creates a new blank row beneath the last row.

You can change menu names and mnemonics at any time.

To delete a menu entry from the table, clear both the name field and the mnemonic field. To verify that the entry has been deleted, you can momentarily switch to another configuration page and return to the 'User Menu List' page. The entry will have been removed.

If you delete a menu that is referenced by another menu, the referencing button is converted to a "not assigned" button.

You cannot modify menu IDs. The IDs are automatically assigned.

## Menu Layouts

▲ This configuration page applies *only* to the SCP. The configuration editor does not display this page for other panel types.

This is the 'Menu Layouts' configuration page:

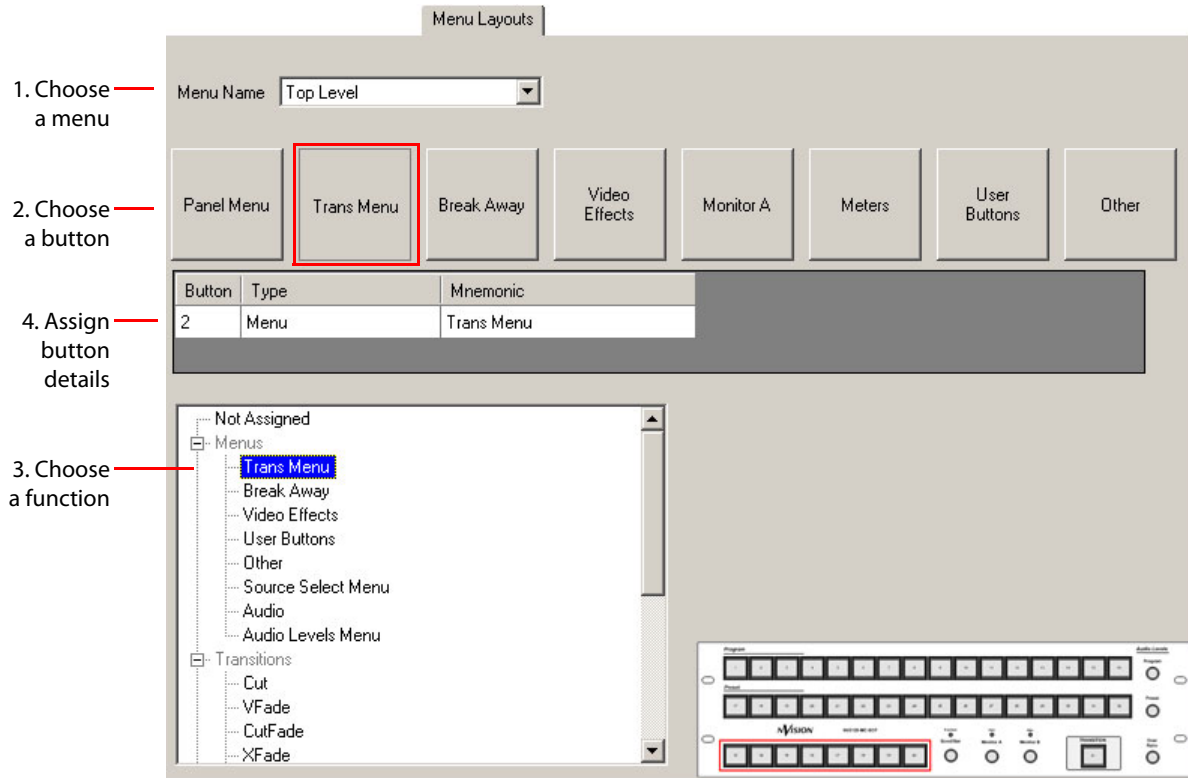

Fig. 5-9: Menu Layouts Page (Sample, SCP)

The page illustrated in Figure 5-9 is the top level menu in the default SCP configuration that ships with the master control configuration software.

The SCP provides a hierarchical (tree-structured) menu system. This is the configuration page in which to construct the menus for your menu hierarchy.

The menu area of the SCP has 8 buttons. The leftmost menu button is always reserved. It either (1) takes the operator "home" or back to the main menu or (2) at the main menu level, takes the operator to the built-in (non-configurable) 'Panel' menu.

Each of the rightmost 7 buttons can be assigned one of many functions. There are several broad classes of buttons:

- Navigation buttons take the operator to other menus.
- Functional buttons perform a task.
- List buttons cause the menu system to display a scrollable list of items from which you can select one of the items.
- System functions are built-in (not configurable) functions usually accessed through the panel menu.

Refer to Chapter 6, [Button Functions \(for MCEs and MCPMs\)](#), for a description of the button types and their associated fields.

Follow these guidelines to define a menu:

- 1 Choose a menu in the drop-down list at the top of the page. The entries in this list (besides "Top Level" which always exists) are the menus you entered on the 'User Menu List' configuration page.
- 2 Choose one of the 8 button proxies. (You can choose the left-most button, but you cannot redefine it. That button is reserved on any menu.)
- 3 Select a button function from the button type list at the bottom of the page. You can expand or collapse the list as you require. Click a "+" to expand an entry; click "-" to collapse the entry.
- 4 Complete the button details in the table in the middle of the page. The button fields in the table row vary with the button type.

In the example of Figure 5-9, a menu selection button is being configured. The only button detail is the button's mnemonic which is the menu's mnemonic (which was defined in the 'User Menu List' page). Therefore, no further detail is required for this button.

## Aux Delegates

▲ This configuration page does not apply to the FFCP, CFCP, PC GUI, or SCP.

This is a representative 'Aux Delegates' configuration page for all panels **but** the Aux/Preview GUI:

1. Choose a button

2. Choose a function

3. Assign button legend

| Button | Type      | Mnemonic  |
|--------|-----------|-----------|
| 2      | Aux Bus B | AUX B BUS |

This is a representative 'Aux Delegates' configuration page for the Aux/Preview GUI:

1. Choose a button

2. Choose a function

3. Assign button legend

| Button | Type      | Mnemonic  |
|--------|-----------|-----------|
| 2      | Aux Bus B | AUX B BUS |

This configuration page assigns “delegate” buttons to the panel’s aux bus. A delegate button determines the function of the aux bus.

- ▲ The aux buttons are active (enabled) only when the panel controls an MCE.

Depending on the number of main sources chosen for a CECP, CECP-GUI, iMC-Panel-100, iMC-Panel-200, iMC-Panel-GUI, or Aux/Preview GUI, there might be room for fewer than 6 delegate buttons. Aux delegate positions assigned to main sources are noted in this configuration page:



- ▲ You can also assign aux delegate functions to any of panel’s configurable buttons (user buttons or bottom row buttons).

The FECP and the iMC-Panel-300 always have 6 buttons available for delegates. A delegate button can be blank if you specify ‘Not Assigned’ as the button function.

To assign a function to a button, first click the button proxy of your choice, then select a button type in the list at the bottom of the page.

When you have chosen a button type, you can change the button legend as you want. Its mnemonic can be whatever you want (up to 24 characters). It should make sense to the panel operator.

The example above, shows an ‘Aux B Bus’ button is being configured.

The delegates determine the function of the aux bus. These are the 6 aux delegate types:

- Aux Bus A  
The main source selected on the aux bus appears at the MCE’s aux A output.
- Aux Bus B  
The main source selected on the aux bus appears at the MCE’s aux B output.
- Preset Squeeze Background  
The main source selected on the aux bus becomes the preset squeeze background image.
  - ▲ This delegate type is not available in the Aux/Preview GUI.
- Preset Squeeze Image2  
The main source selected on the aux bus becomes the preset squeeze image 2.
  - ▲ This delegate type is not available in the Aux/Preview GUI.
- Preview Squeeze Background  
The main source selected on the aux bus becomes the preview squeeze background image.
- Preview Squeeze Image2  
The main source selected on the aux bus becomes the preview squeeze image 2.

## Audio Monitoring Layout

- ▲ This configuration page applies *only* to the FECP and the iMC-Panel-300. The configuration editor does not display this page for configurations of other panel types.
- ▲ The 'Audio Monitoring Layout' page for panels controlling an Imagestore 750 are different. This is the 'Audio Monitoring Layout' configuration page:

1. Choose a button

2. Choose a function

3. Assign button legend

| Button | Type          | Mnemonic  |
|--------|---------------|-----------|
| 1      | Monitor A Pgm | Pgm Mon A |

Fig. 5-10: Audio Monitoring Layout Page (Sample, iMC-Panel-300)

This configuration page assigns audio functions to buttons in the panel's audio monitor/metering section. There are 5 audio sources that can be assigned to each of the section's outputs (monitor A, metering, and monitor B):

Program audio      Off-air audio  
Preset audio      Aux in audio  
Preview audio

(The meaning of "aux in" here is a set of up to 16 audio inputs at the master control frame's backplane. It is nothing to do with the aux buttons of the panel, the aux outputs of an MCE, or the 'AUX' input at the back of the panel. These aux inputs are configurable in MasterConfig.)

(The meaning of "off-air" here is the same: a set of up to 16 audio inputs at the master control frame's backplane.)

To assign a function to a button, first click the button proxy of your choice, then select a button type in the list at the bottom of the page.

When you have chosen a button type, you can change the button legend as you want. Its mnemonic can be whatever you want (up to 24 characters). It should make sense to the panel operator.

## Operation (for MCEs and MCPMs)

### Operation (for MCEs and MCPMs)

---

The example above, shows the defaults. In this example, the first button is being configured to send program audio to monitor A.

You can configure any of these buttons as 'Not Assigned' in which case the button has no function and will remain dark.

If you configure all the buttons in any row as 'Not Assigned', the operator cannot change the monitor or meter's source and the monitor will output what was configured for the MCPM or MCE under control.

▲ Important: the legends on the iMC-Panel-300's audio monitor/meter section are by row:

Row 1 is labeled "Monitor A"

Row 2 is labeled "Meter"

Row 3 is labeled "Monitor B"

Furthermore, the monitor A gain and dim buttons are at the right of the row labeled "Monitor A" and the monitor B gain and dim buttons are at the right of the row labeled "Monitor B."

Contrary to this layout, the configurable audio buttons are all absolutely independent. Thus, for example, the 'Meter Preview' button function places the preview audio on the meter output regardless of in which row you place it.

The upper gain and dim controls affect only monitor A output and the lower gain and dim controls affect only monitor B output. The panel operator must be cautioned that if there are meter or monitor B functions on the top row, say, the gain and dim controls do not affect meter output or monitor B output.

## Audio Macros

- ▲ This configuration page does not apply to the FFCP, CFCP, PC GUI, or SCP.
- ▲ Audio macros apply only when the panel is controlling an MCE.

This is the 'Audio Macro' configuration page:

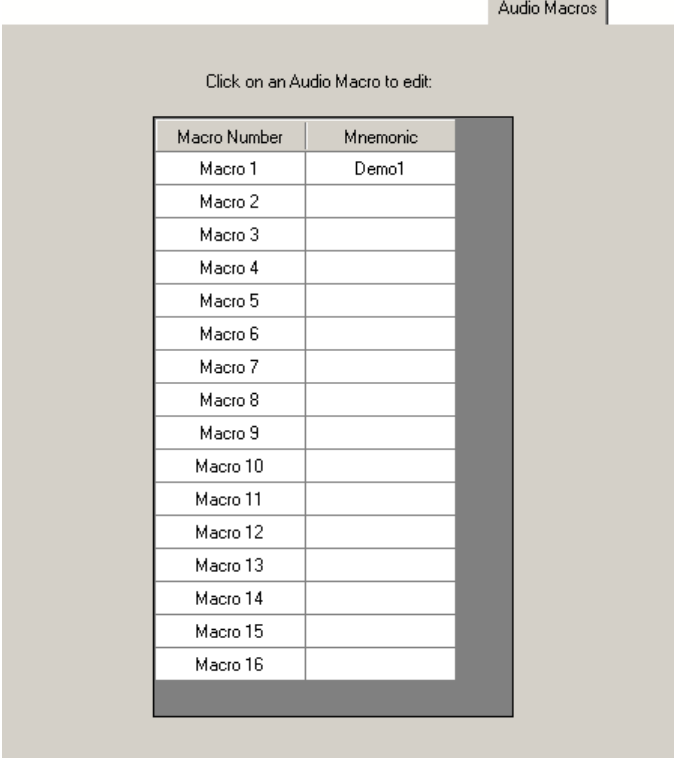

| Macro Number | Mnemonic |
|--------------|----------|
| Macro 1      | Demo1    |
| Macro 2      |          |
| Macro 3      |          |
| Macro 4      |          |
| Macro 5      |          |
| Macro 6      |          |
| Macro 7      |          |
| Macro 8      |          |
| Macro 9      |          |
| Macro 10     |          |
| Macro 11     |          |
| Macro 12     |          |
| Macro 13     |          |
| Macro 14     |          |
| Macro 15     |          |
| Macro 16     |          |

Fig. 5-11: Audio Macro Page (Sample, iMC-Panel-300)

This configuration page allows you to define up to 16 audio macros.

*What is an audio macro?* An audio macro is a predefined 16×16 mapping for the audio cross-point of an MCE. Each entry in the mapping also specifies the gain for the audio output channel.

You must give every macro you define a mnemonic name.

Macros must be defined in this page before you can assign them to buttons in the [User Button Layout](#) page or the [Bottom Row Layout](#) page. After you define at least one macro, an additional entry appears in the button categories list: 'Audio Macros'. If you expand that category (by clicking the plus sign) you will see the mnemonics for the macros you defined.

## Operation (for MCEs and MCPMs)

Operation (for MCEs and MCPMs)

---

This particular sample shows a reverse diagonal mapping:

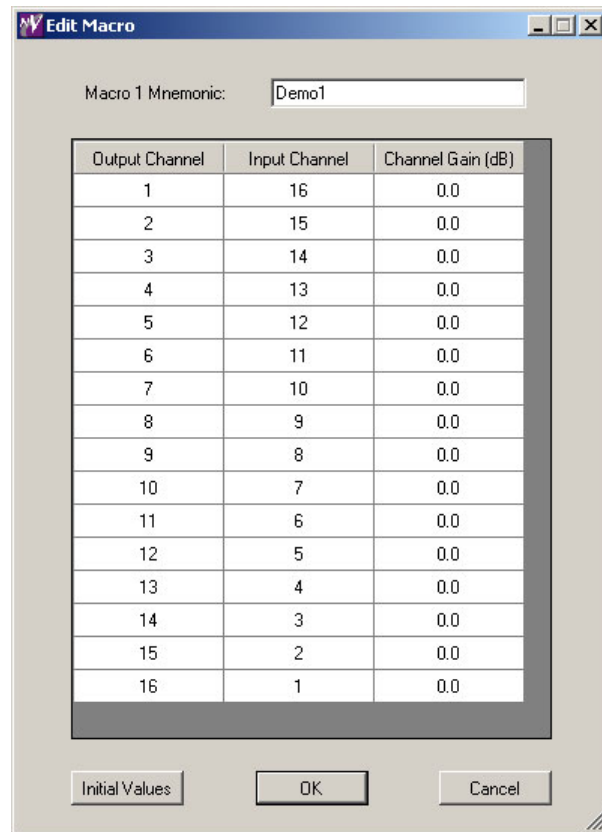

Blank entries mean the (output) channel is not used.

Click the 'Initial Value' button to populate the audio crosspoint with a diagonal mapping having unity gain. (Note that 0.0 dB means unity gain.)



# 6

## Button Functions (for MCEs and MCPMs)

Chapter 6 describes the configurable button types for panels when they are controlling MCEs and MCPMs.

### Topics

|   |     |
|---|-----|
| <i>Summary</i> .....                    | 131 |
| <i>Definable Button Functions</i> ..... | 134 |

(See chapter 8 on page 181 for information about button types for use with Imagestore 750s.)

### Summary

The MCS Panel Configuration Editor configures these control panels:

|               |               |                 |               |
|---------------|---------------|-----------------|---------------|
| iMC-Panel-300 | iMC-Panel-200 | iMC-Panel-GUI   | iMC-Panel-100 |
| FCEP          | CECP          | CECP GUI        | SCP           |
| FFCP          | CFCP          | PC GUI          |               |
|               | CECP M1       | Aux/Preview GUI |               |

The panels have a common “core” set of button functions, but of course, each panel is different. Table , next page, lists the core functions. There are 42 core functions plus groups of other functions that differ from panel to panel.

The SCP is different from the other panels because its menu system is implemented on buttons. Therefore it has additional button functions. Also, because its menu is hierarchical (tree-structured) it can have menu-selection buttons defined by the customer and which cannot be described here.

All panels but the SCP have two or more sets of customer-configurable buttons. The configuration editor calls these, as applicable:

- User buttons.
- Bottom row buttons.
- Top row buttons.
- Preview/user buttons.
- Aux/user buttons.

For older panels, the buttons belonging to the ‘user’ set differ from the buttons belonging to the ‘bottom row’ set. The columns labeled ‘User’ and ‘Bot.’ in the following table represent these two sets of buttons.

## Button Functions (for MCEs and MCPMs)

### Button Functions (for MCEs and MCPMs)

#### Core Button Set for Panels Controlling MCEs and MCPMs

| Function               | iMC-Panel-100 | CECP, iMC-Panel-200 | FECP, iMC-Panel-300 | CECP GUI, iMC-Panel-GUI | Aux/Pvw GUI | FFCP |      | CFCP |      | PC GUI |      | SCP |   |
|------------------------|---------------|---------------------|---------------------|-------------------------|-------------|------|------|------|------|--------|------|-----|---|
|                        |               |                     |                     |                         |             | User | Bot. | User | Bot. | User   | Bot. |     |   |
| <b>Transition type</b> |               |                     |                     |                         |             |      |      |      |      |        |      |     |   |
| Cut                    | ✓             | ✓                   | ✓                   | ✓                       | No          | ✓    | ✓    | ✓    | ✓    | ✓      | ✓    | ✓   |   |
| V-fade                 | ✓             | ✓                   | ✓                   | ✓                       |             | ✓    | ✓    | ✓    | ✓    | ✓      | ✓    | ✓   | ✓ |
| Cut fade               | ✓             | ✓                   | ✓                   | ✓                       |             | ✓    | ✓    | ✓    | ✓    | ✓      | ✓    | ✓   | ✓ |
| X-fade                 | ✓             | ✓                   | ✓                   | ✓                       |             | ✓    | ✓    | ✓    | ✓    | ✓      | ✓    | ✓   | ✓ |
| Fade cut               | ✓             | ✓                   | ✓                   | ✓                       |             | ✓    | ✓    | ✓    | ✓    | ✓      | ✓    | ✓   | ✓ |
| PB cut                 | ✓             | ✓                   | ✓                   | ✓                       |             | ✓    | ✓    | ✓    | ✓    | ✓      | ✓    | ✓   | ✓ |
| PB V-fade              | ✓             | ✓                   | ✓                   | ✓                       |             | ✓    | ✓    | ✓    | ✓    | ✓      | ✓    | ✓   | ✓ |
| PB cut fade            | ✓             | ✓                   | ✓                   | ✓                       |             | ✓    | ✓    | ✓    | ✓    | ✓      | ✓    | ✓   | ✓ |
| PB fade cut            | ✓             | ✓                   | ✓                   | ✓                       |             | ✓    | ✓    | ✓    | ✓    | ✓      | ✓    | ✓   | ✓ |
| <b>Transition rate</b> |               |                     |                     |                         |             |      |      |      |      |        |      |     |   |
| Slow                   | ✓             | ✓                   | ✓                   | ✓                       | No          | ✓    | ✓    | ✓    | ✓    | ✓      | ✓    | ✓   |   |
| Medium                 | ✓             | ✓                   | ✓                   | ✓                       |             | ✓    | ✓    | ✓    | ✓    | ✓      | ✓    | ✓   | ✓ |
| Fast                   | ✓             | ✓                   | ✓                   | ✓                       |             | ✓    | ✓    | ✓    | ✓    | ✓      | ✓    | ✓   | ✓ |
| <b>GPI</b>             |               |                     |                     |                         |             |      |      |      |      |        |      |     |   |
| GPI MCPM [out]         | ✓             | ✓                   | ✓                   | ✓                       | ✓           | ✓    | ✓    | ✓    | ✓    | ✓      | ✓    | ✓   |   |
| GPI MCPM in            | ✓             | ✓                   | ✓                   | ✓                       | ✓           | ✓    | ✓    | ✓    | ✓    | ✓      | ✓    | ✓   |   |
| GPI Panel [out]        | ✓             | ✓                   | ✓                   | No                      | No          | ✓    | ✓    | ✓    | ✓    | No     |      | ✓   |   |
| GPI Panel in           | ✓             | ✓                   | ✓                   | ✓                       | ✓           | ✓    | ✓    | ✓    | ✓    | ✓      | ✓    | ✓   |   |
| GPI in/out             | ✓             | ✓                   | ✓                   | ✓                       | ✓           | ✓    | ✓    | ✓    | ✓    | ✓      | ✓    | ✓   |   |
| <b>Channel</b>         |               |                     |                     |                         |             |      |      |      |      |        |      |     |   |
| Channel (select)       | ✓             | ✓                   | ✓                   | ✓                       | ✓           | ✓    | No   | ✓    | No   | ✓      | No   | ✓   |   |
| Salvo                  | ✓             | ✓                   | ✓                   | ✓                       | ✓           | ✓    |      | ✓    |      | ✓      |      | ✓   | ✓ |
| Gang channels          | ✓             | ✓                   | ✓                   | ✓                       | ✓           | ✓    |      | ✓    |      | ✓      |      | ✓   | ✓ |
| No channels            | ✓             | ✓                   | ✓                   | ✓                       | ✓           | ✓    | ✓    | ✓    | ✓    | ✓      | ✓    | ✓   |   |
| Channel status         | ✓             | ✓                   | ✓                   | ✓                       | ✓           | No   | No   | No   | No   | No     | No   | ✓   |   |
| Channel control        | ✓             | ✓                   | ✓                   | ✓                       | ✓           | No   | No   | No   | No   | No     | No   | ✓   |   |
| <b>Audio</b>           |               |                     |                     |                         |             |      |      |      |      |        |      |     |   |
| Dim A                  | ✓             | ✓                   | ✓                   | ✓                       | ✓           | ✓    | No   | ✓    | No   | ✓      | No   | ✓   |   |
| Dim B                  | ✓             | ✓                   | ✓                   | ✓                       | ✓           | ✓    |      | ✓    |      | ✓      |      | ✓   | ✓ |
| Pgm FBA status         | ✓             | ✓                   | ✓                   | ✓                       | ✓           | ✓    |      | ✓    |      | ✓      |      | ✓   | ✓ |
| Pgm FBA control        | ✓             | ✓                   | ✓                   | ✓                       | No          | ✓    | ✓    | ✓    | ✓    | ✓      | ✓    | ✓   |   |
| Pst FBA status         | ✓             | ✓                   | ✓                   | ✓                       |             | ✓    | ✓    | ✓    | ✓    | ✓      | ✓    | ✓   | ✓ |
| Pst FBA control        | ✓             | ✓                   | ✓                   | ✓                       | ✓           | ✓    | ✓    | ✓    | ✓    | ✓      | ✓    | ✓   |   |
| Pvw FBA status         | ✓             | ✓                   | ✓                   | ✓                       | ✓           | No   | No   | No   | No   | No     | No   | No  |   |
| Pvw FBA control        | ✓             | ✓                   | ✓                   | ✓                       | ✓           | No   | No   | No   | No   | No     | No   | No  |   |
| Audio Lock             | ✓             | ✓                   | ✓                   | No                      | No          | No   | No   | No   | No   | No     | No   | ✓   |   |

### Core Button Set for Panels Controlling MCEs and MCPMs

| Function         | iMC-Panel-100 | CECP, iMC-Panel-200 | FECP, iMC-Panel-300 | CECP GUI, iMC-Panel-GUI | Aux/Pvw GUI | FFCP |      | CFCP |      | PC GUI |      | SCP |
|------------------|---------------|---------------------|---------------------|-------------------------|-------------|------|------|------|------|--------|------|-----|
|                  |               |                     |                     |                         |             | User | Bot. | User | Bot. | User   | Bot. |     |
| <b>Utility</b>   |               |                     |                     |                         |             |      |      |      |      |        |      |     |
| Panel lock       | ✓             | ✓                   | ✓                   | ✓                       | ✓           | ✓    | ✓    | ✓    | ✓    | ✓      | ✓    | ✓   |
| Fade to black    | ✓             | ✓                   | ✓                   | ✓                       | ✓           | ✓    | ✓    | ✓    | ✓    | ✓      | ✓    | ✓   |
| Auto[mation] off | ✓             | ✓                   | ✓                   | ✓                       | ✓           | ✓    | ✓    | ✓    | ✓    | ✓      | ✓    | ✓   |
| Audio only       | ✓             | ✓                   | ✓                   | ✓                       | No          | ✓    | ✓    | ✓    | ✓    | ✓      | ✓    | ✓   |
| Video only       | ✓             | ✓                   | ✓                   | ✓                       |             | ✓    | ✓    | ✓    | ✓    | ✓      | ✓    | ✓   |
| Flip flop [mode] | ✓             | ✓                   | ✓                   | ✓                       |             | ✓    | ✓    | ✓    | ✓    | ✓      | ✓    | ✓   |
| EB status        | ✓             | ✓                   | ✓                   | ✓                       | ✓           | ✓    | ✓    | ✓    | ✓    | ✓      | ✓    | ✓   |
| EB control       | ✓             | ✓                   | ✓                   | ✓                       | ✓           | ✓    | ✓    | ✓    | ✓    | ✓      | ✓    | ✓   |
| KaleidoX layout  | ✓             | ✓                   | ✓                   | ✓                       | ✓           | No   | No   | No   | No   | No     |      | ✓   |
| Bank select      | ✓             | ✓                   | No                  | ✓                       | ✓           | No   | No   | ✓    | ✓    |        |      | ✓   |
| Transition hold  | ✓             | ✓                   | ✓                   | ✓                       | No          | ✓    | ✓    | ✓    | ✓    |        |      | ✓   |
| Menu             | ✓             | ✓                   | ✓                   | ✓                       | ✓           | No   | No   | No   | No   | No     |      | No  |
| Group Select     | ✓             | ✓                   | ✓                   | ✓                       | ✓           | No   | No   | No   | No   |        |      | No  |

## SCP

These are the additional buttons the SCP provides:

| Audio (9)            | Utility (4)            | Effects (7)      | Machine Control (10) |
|----------------------|------------------------|------------------|----------------------|
| Monitor A            | System status          | Squeeze select   | Play                 |
| Monitor B            | Preset main button map | Keyer 1 select   | Stop                 |
| Meters               | Preset over button map | Keyer 2 select   | Fast Forward         |
| Pst main audio level | Preset main router     | Keyer 2 select   | Rewind               |
| Pst over audio ratio |                        | Logo A select    | Cue                  |
| Pst over audio level |                        | Logo B select    | Pause                |
| Pgm main audio level |                        |                  | Preroll              |
| Pgm over audio ratio |                        | XG Keyer Control | Abort                |
| Pgm over audio level |                        |                  | Ready                |
|                      |                        |                  | Mark                 |

With these additions, the SCP has a total of 71 button functions.

## Newer Panels

These are additional buttons the CECP, CECP M1, CECP GUI, FECP, iMC-Panel-100, iMC-Panel-200, iMC-Panel-GUI, iMC-Panel-300, and Aux/Preview GUI provide:

| Aux Delegates (6)                      | Machine Control (10) | Intuition XG (1) |
|--|----------------------|------------------|
| Aux bus A                              | Play                 | XG Keyer Control |
| Aux bus B                              | Stop                 |                  |
| Preset squeeze background <sup>a</sup> | Fast Forward         |                  |
| Preset squeeze image 2 <sup>a</sup>    | Rewind               |                  |
| Preview squeeze background             | Cue                  |                  |
| Preview squeeze image 2                | Pause                |                  |
|  | Preroll              |                  |
|  | Abort                |                  |
|  | Ready                |                  |
|  | Mark                 |                  |

a. The Aux/Preview GUI does not have these 2 buttons.

## Button Functions (for MCEs and MCPMs)

Button Functions (for MCEs and MCPMs)

---

See [Aux Delegates](#) on page 125.

The CECP M1 has two additional button types: Live Levels A and Live Levels B. (These switch the live levels display to metering input A and B, respectively.)

## FECF and iMC-Panel-300

These are additional buttons the FECF and iMC-Panel-300 provide. They exist because of its physical layout:

| Monitor A (5) | Meter (5) | Monitor B (5) |
|---------------|-----------|---------------|
| Program       | Program   | Program       |
| Preset        | Preset    | Preset        |
| Preview       | Preview   | Preview       |
| Off-Air       | Off-Air   | Off-Air       |
| Aux           | Aux       | Aux           |

See [Audio Monitoring Layout](#) on page 127.

## Audio Macros

For the CECP, CECP M1, CECP GUI, iMC-Panel-100, iMC-Panel-200, iMC-Panel-300, iMC-Panel-GUI, and Aux/Preview GUI, configurers may create up to 16 audio macros and assign them to buttons. See [Audio Macros](#) on page 129.

## Definable Button Functions

This table lists the button function classes:

|                                |                                  |                                      |  |
|--------------------------------|----------------------------------|--------------------------------------|--|
| <a href="#">Channel</a>        | <a href="#">Flip-Flop</a>        | <a href="#">Transition Rate</a>      | <a href="#">Dynamic Source Buttons</a> |
| <a href="#">Salvo</a>          | <a href="#">Bank Select</a>      | <a href="#">Breakaway</a>            | <a href="#">Video Effects</a>          |
| <a href="#">GPI</a>            | <a href="#">Emergency Bypass</a> | <a href="#">‘Dim’ Buttons</a>        | <a href="#">Menu Buttons</a>           |
| <a href="#">System Control</a> | <a href="#">Transition Type</a>  | <a href="#">Dolby E Backup Audio</a> | <a href="#">Audio</a>                  |
| <a href="#">Audio Macros</a>   | <a href="#">Machine Control</a>  | <a href="#">XG Keyer Control</a>     | <a href="#">Aux Delegates</a>          |

Following are descriptions of the functions that can be assigned to buttons during configuration. If you are viewing this document on a computer, you can use the table to jump to the various topics.

For the SCP, these buttons are configured on the [Menu Layouts](#) page. For other panels, these buttons are configured on the [User Button Layout](#) page or the [Bottom Row Layout](#) page.

In the following definitions, a button “proxy” is a square figure on the configuration page that represents a button and its current assignment. A blank proxy is an unassigned button.

- ▲ Several button types (such as ‘Panel Lock’) become unavailable (and are displayed in gray) if they have already been assigned to a button.
- ▲ Status buttons do nothing when pressed.

## Not Assigned

This kind of button has no function. On the panel, the button’s legend is blank and the button light is off. (The panel can never enable or disable this kind of button.)

## Channel

An MCPM or an MCE is called a *channel*. A typical panel configuration provides a set of channel selection buttons. A channel can be configured to invoke an NV9000 salvo when selected.

- ▲ Salvos assigned to channels are inhibited for ganged channels.

There are 5 channels functions:

- 'Channel' selection.
- 'No Channels'.
- 'Gang Channels'.
- 'Channel Status'.
- 'Channel Control'.

## Channel Select

To configure a 'Channel Select' button:

- 1 Click a button proxy.
- 2 Find and choose 'Channel' in the button type list.
- 3 Choose one of the defined channels in the 'Channel Selection' drop-down list.  
The channels must have been defined in the [Channel Selection List](#) page.
- 4 The 'Mnemonic' field displays the channel name. You cannot modify this field. (However, you can change the channel name in the 'Channel Selection List' configuration page.)

This is an example:

| Button | Type    | Mnemonic | Channel Selection |
|--------|---------|----------|-------------------|
| 1      | Channel | CH1      | 192.168.7.10      |

192.168.7.10  
192.168.7.20  
192.168.7.30

- ▲ Only one channel selection button may be assigned to a channel.

(On the CECP M1 only, A channel selection might be configured to switch the live levels display to metering input A or to metering input B.)

When a channel selection button applies to the default channel (designated in the [Channel Selection List](#) page) and [automatic gang mode](#) applies, the channel selection button selects the default channel and each of its followers as well. (The default channel is the main channel and its button appears green. Buttons for its follower channels appear amber.)

## No Channels

A 'No Channels' button quickly disconnects the panel from all MCPMs. (To restore operation, the operator selects any channel.)

To configure a 'No Channels' button:

- 1 Click a button proxy.
- 2 Choose 'No Channel' in the button type list.
- 3 Optionally, change the button caption in the 'Mnemonic' field.

## Button Functions (for MCEs and MCPMs)

### Button Functions (for MCEs and MCPMs)

---

This is an example:

| Button | Type        | Mnemonic    |
|--------|-------------|-------------|
| 2      | No Channels | No Channels |

- ▲ A panel configuration can have only one 'No Channel' button.

### Gang Channels

A 'Gang Channels' button lets an operator couple two or more channels. It is a toggle that enables or disables ganged operation. When channels are ganged, any action performed on the "main" channel is also performed on all selected "follower" channels.

In [automatic gang mode](#), the channel designated as the default channel can be ganged (with its followers) automatically when the channel is selected. The 'Gang Channels' button has the effect of "un-ganging" an automatically created channel gang.

To configure a 'Gang Channels' button:

- 1 Click a button proxy.
- 2 Choose 'Gang Channels' in the button type list.
- 3 Optionally, change the button caption in the 'Mnemonic' field.

This is an example:

| Button | Type          | Mnemonic      |
|--------|---------------|---------------|
| 2      | Gang Channels | Gang Channels |

- ▲ A panel operator can gang at most 4 channels.
- ▲ When gang selection is enabled, salvos assigned to channels are inhibited.
- ▲ Ganged channels must be either all Imagestore 750s or all MCEs and MCPMs.

### Channel Status

A 'Channel Status' button displays the name of the currently selected channel. It is normally white, indicating that it is status-only, but it will turn red if the channel has a problem.

To configure a 'Channel Status' button:

- 1 Click a button proxy.
- 2 Choose 'Channel Status' in the button type list.
- 3 Optionally, change the button caption in the 'Mnemonic' field.

This is an example:

| Button | Type           | Mnemonic       |
|--------|----------------|----------------|
| 2      | Channel Status | Channel Status |

### Channel Control

A 'Channel Control' button is primarily for testing, but might have some use in your facility. A channel control button reacquires the currently selected channel. A channel control button is white, displaying the channel name, but it is also an active button. (A channel control button turns red briefly while the panel reacquires the channel.)

If the active channel is the default channel and [automatic gang mode](#) is in effect, pressing the 'Channel Control' button reselects the automatic channel gang.

To configure a 'Channel Control' button:

- 1 Click a button proxy.
- 2 Choose 'Channel Control' in the button type list.
- 3 Optionally, change the button caption in the 'Mnemonic' field.

This is an example:

| Button | Type            | Mnemonic        |
|--------|-----------------|-----------------|
| 2      | Channel Control | Channel Control |

## Salvo

A salvo button causes an NV9000 salvo to execute. (Configuring this button requires a connected NV9000 router control system.)

- ▲ A channel change can also execute a salvo.
- ▲ When channel gang selection is enabled, salvos are inhibited.
- ▲ If [automatic gang mode](#) is in effect, salvos are also inhibited.

To configure a 'Salvo' button:

- 1 Click a button proxy.
- 2 Choose 'Salvo' in the 'Type' field.
- 3 Choose one of the defined salvos in the 'Salvo ID' drop-down list.

The name of the selected salvo (defined in the NV9000 configuration) appears in the 'Mnemonic' field as a provisional button caption. You can use the salvo name or enter a button caption of your own. The salvo ID appears in the 'Salvo ID' field.

This is an example:

| Button | Type  | Mnemonic | Salvo ID  |
|--------|-------|----------|---|
| 1      | Salvo | MCT 1080 | 5   |
|        |       |          | [Clear Entry]<br>DevName:3<br>MCT 1080:5<br>MCT 525:6<br>MCT 720p:4<br>Salvo2:2 |

If you do not have an NV9000 system attached, the configuration editor cannot obtain salvo information. In that situation, you will enter the salvo ID numerically. The 'Attach to NV9000' command is in the [NV9000 Settings](#) page.

## GPI

A hardware panel has a connector that provides 2 relay outputs and 2 optically isolated TTL-level inputs. These are GPI ports. The relays can control external devices. The inputs can sense external events in your system.

## Button Functions (for MCEs and MCPMs)

### Button Functions (for MCEs and MCPMs)

---

MCPMs also have 2 GPI inputs and 2 GPI outputs. Combined, there are a total of 8 usable GPI ports. There are 5 GPI button types that can be present on a panel:

---

|                               |   |
|-------------------------------|---|
| Panel GPI input               | Displays status of one of the 2 inputs on the panel.  |
| Panel GPI output              | Controls one of the 2 relays on the panel.  |
| Combined GPI input and output | Displays status of one input (panel or MCPM) and controls one output (panel or MCPM).               |
| MCPM GPI input                | Displays status of one of the 2 inputs on the currently selected MCPM.                              |
| MCPM GPI output               | Controls one of the 2 relays on the currently selected MCPM (if the MCPM configuration permits it). |

---

- ▲ A panel configuration does not allow any GPI port to be represented by more than one button.

### GPI Output

A GPI output button (panel or MCPM) is a toggle: when it is deselected, the associated relay's "normally open" circuit is open. When it is selected, the relay's "normally open" circuit is closed.

To configure a panel GPI output button:

- 1 Click a button proxy.
- 2 Choose 'GPI-Panel' in the button type list.
- 3 Select a GPI output number in the 'GPI Number' drop-down list.
- 4 Enter a button caption in the 'Mnemonic' field.

This is an example:

| Button | Type      | Mnemonic  | GPI Number  |
|--------|-----------|-----------|---|
| 2      | GPI Panel | GPI Panel | GPI 1  |

To configure an MCPM GPI output button:

- 1 Click a button proxy.
- 2 Choose 'GPI-MCPM' in the button type list.
- 3 Select a GPI output number in the 'GPI Number' drop-down list.
- 4 Enter a button caption in the 'Mnemonic' field.

This is an example:

| Button | Type     | Mnemonic | GPI Number  |
|--------|----------|----------|---|
| 2      | GPI MCPM | GPI MCPM | GPI 1  |

### GPI Input

A GPI input button displays the state of a GPI input. There are 2 options:

- 1 The button is high-tally when the GPI input is inactive (no current or "open" circuit).
- 2 The button is high-tally when the GPI input is active (current flowing or "closed" circuit).

To configure a panel GPI input button:

- 1 Click a button proxy.
- 2 Choose 'GPI Panel In' in the button type list.



- 3 Select a GPI input number in the 'GPI Number' drop-down list.
  - 4 Enter a button caption in the 'Mnemonic' field.
  - 5 Choose either 'Open is Selected' or 'Closed is Selected' in the 'Sense' drop-down list.
- The word 'Selected' means the button is high-tally. "Open is selected" corresponds to option 1 (mentioned above); "Closed is selected" corresponds to option 2.

This is an example:

| Button | Type         | Mnemonic     | GPI Number | Sense         |
|--------|--------------|--------------|------------|---------------|
| 2      | GPI Panel In | GPI Panel In | GPI 2      | Not Specified |

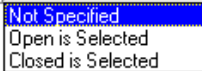

To configure an MCPM GPI input button:

- 1 Click a button proxy.
  - 2 Choose 'GPI MCPM In' in the button type list.
  - 3 Select a GPI input number in the 'GPI Number' drop-down list.
  - 4 Enter a button caption in the 'Mnemonic' field.
  - 5 Choose either 'Open is Selected' or 'Closed is Selected' in the 'Sense' drop-down list.
- The word 'Selected' means the button is high-tally. "Open is selected" corresponds to option 1; "Closed is selected" corresponds to option 2.

This is an example:

| Button | Type        | Mnemonic    | GPI Number | Sense         |
|--------|-------------|-------------|------------|---------------|
| 2      | GPI MCPM In | GPI MCPM In | GPI 2      | Not Specified |

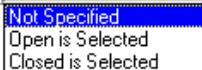

## GPI Input and Output

A combined GPI input and output button performs 2 functions.

- The illumination of the button represents the state of a GPI input as for GPI input buttons.
- Pressing the button toggles the state of a relay, as for GPI output buttons. The button displays the state of the designated input (and not the designated output).

The input can be either a panel or MCPM input; the output can be either a panel or MCPM output.

To configure a GPI input/output button:

- 1 Click a button proxy.
  - 2 Choose 'GPI In/Out' in the button type list.
  - 3 Enter a button caption in the 'Mnemonic' field.
  - 4 Select a GPI input number in the 'GPI In' drop-down list.
  - 5 Choose either 'Open is Selected' or 'Closed is Selected' in the 'Sense' drop-down list.
- This applies to the GPI input. "Open is selected" means the button is high-tally when the input circuit is open; "Closed is selected" means the button is high-tally when the circuit is closed.
- 6 Select a GPI output number in the 'GPI Out' drop-down list.

## Button Functions (for MCEs and MCPMs)

### Button Functions (for MCEs and MCPMs)

---

This is an example:

| Button | Type       | Mnemonic   | GPI In          | Sense           | GPI Out  |
|--------|------------|------------|-----------------|-----------------|--|
| 2      | GPI In/Out | GPI In/Out | Not Specified ▼ | Not Specified ▼ | Not Specified ▼<br>Not Specified<br>Panel 1<br>Panel 2<br>MCPM 1<br>MCPM 2 |

- ▲ Refer to the *Master Control Reference Manual* or the *MasterConfig User's Guide* for information about using MCPM GPI inputs and outputs.

## System Control

There are several system control button *types* that can be present on a panel. System control functions include:

|                 |              |                          |
|-----------------|--------------|--------------------------|
| Panel Lock      | Auto Off     | Fade-to-Black            |
| Transition Hold | Audio Lock   | System Status (SCP only) |
| KaleidoX Layout | Group Select |                          |

Not all of these are available on all panels. See Table on page 132 for a comparison.

### Panel Lock

The panel lock button prevents anyone from accidentally making changes at the panel.

A panel lock button is a toggle that locks or unlocks the panel.

To configure a 'Panel Lock' button:

- 1 Click a button proxy.
- 2 Choose 'Panel Lock' in the button type list.
- 3 Optionally, change the button caption in the 'Mnemonic' field.

This is an example:

| Button | Type       | Mnemonic   |
|--------|------------|------------|
| 9      | Panel Lock | Panel Lock |

- ▲ A panel configuration can have only one 'Panel Lock' button.

### Automation Off

The 'Automation Off' button is a toggle that enables or disables control of the MCPM by automation. If the currently selected MCPM does not allow the operator to turn automation off and on, the button is disabled (dark). An MCPM can exhibit one of 3 behaviors when automation is turned off:

- Do not reply to automation commands.
- Reply to commands but do not execute the commands.
- Reply to commands with 'error' or 'disabled' messages.

An MCPM has other automation options.

To configure an 'Automation Off' button:

- 1 Click a button proxy.
- 2 Choose 'Auto Off' in button type list.
- 3 Optionally, change the button caption in the 'Mnemonic' field.

This is an example:

| Button | Type     | Mnemonic |
|--------|----------|----------|
| 10     | Auto Off | Auto Off |

### Transition Hold

A 'Transition Hold' button is a button with unique behavior that applies when automation is on. When automation is off or suspended, the button has no noticeable effect.

While the operator holds the button down, an automated transition is suspended. When the operator releases the button, the transition continues. This is a special-purpose button that lets an operator synchronize a transition with a video feed that might be delayed unpredictably.

To configure a 'Transition Hold' button:

- 1 Click a button proxy.
- 2 Choose 'Transition Hold' in the button type list.
- 3 Optionally, change the button caption in the 'Mnemonic' field.

This is an example:

| Button | Type            | Mnemonic  |
|--------|-----------------|-----------|
| 11     | Transition Hold | Tran Hold |

- ▲ A panel configuration can have only one 'Transition Hold' button.

### Fade to Black

A 'Fade To Black' (FTB) button is a toggle that fades the MCPM's program output to, or from, matte/silence. (The matte color is defined in the MCPM configuration.)

To configure a 'Fade to Black' button:

- 1 Click a button proxy.
- 2 Choose 'Fade to Black' in the button type list.
- 3 Optionally, change the button caption in the 'Mnemonic' field.

This is an example:

| Button | Type          | Mnemonic |
|--------|---------------|----------|
| 11     | Fade To Black | FTB      |

### Audio Lock

An 'Audio Lock' button is a toggle that enables or disables the audio level knobs on the iMC-Panel-100, iMC-Panel-200, iMC-Panel-300, CECP, FECP, and SCP. (This feature is designed to prevent accidental changes to the audio levels.)

To configure an 'Audio Lock' button:

- 1 Click a button proxy.
- 2 Choose 'Audio Lock' in the button type list.

## Button Functions (for MCEs and MCPMs)

### Button Functions (for MCEs and MCPMs)

---

3 Optionally, change the button caption in the 'Mnemonic' field.

- This is an example:

| Button | Type       | Mnemonic   |
|--------|------------|------------|
| 4      | Audio Lock | Audio Lock |

## System Status

- ▲ System status buttons are available only on the SCP. (Other panels display status messages on the touchscreen.)

The 'System Status' button displays general error and warning messages. The SCP's panel menu has a 'System Status' button. Your configuration can have more than one.

Table , following, lists the messages, with the higher priority messages at the top of the list. If there are no error or status messages to display, this button displays "OK"—the last message in the table. *Dynamic* (i.e., temporary, as opposed to *static*) messages are displayed for five seconds.

## System Status Messages

| Button Text               | Button Color | Static or Dynamic | Comments   |
|---------------------------|--------------|-------------------|--|
| No Panel Connect          | Red          | Static            |  |
| No Update Connect         | Red          | Static            |  |
| MCPM SW Load Problem      | Red          | Static            |  |
| MCPM Config Problem       | Red          | Static            |  |
| Emergency Bypass Mode     | Red          | Static            |  |
| MCPM in Debug Mode        | Red          | Static            |  |
| No Video Reference        | Red          | Static            |  |
| No Audio Clock            | Red          | Static            |  |
| In Black & Silence        | Red          | Static            |  |
| Panel Major Alarm         | Red          | Static            |  |
| Panel Config Problem      | Red          | Static            |  |
| No Panel Config           | Red          | Static            |  |
| Panel SW Load Problem     | Red          | Static            |  |
| In Trans                  | Amber        | Dynamic           | This message appears when a request fails because the MCPM is currently in a transition. |
| Send Cmd to MCPM Problem  | Amber        | Dynamic           |  |
| Receive from MCPM Problem | Amber        | Dynamic           |  |
| Minor Panel Alarm         | Amber        | Static            |  |
| NV9000 Data Problem       | Amber        | Dynamic           |  |
| Ethernet Problem          | Amber        | Dynamic           |  |
| Internal Panel SW Problem | Amber        | Dynamic           |  |
| OK                        | White        | Static            |  |

Pressing a 'System Status' button has no effect.

To configure a 'System Status' button:

- 1 Click a button proxy.
- 2 Choose 'System Status' in the button type list.
- 3 Optionally, change the button caption in the 'Mnemonic' field.

This is an example:

| Button | Type          | Mnemonic      |
|--------|---------------|---------------|
| 2      | System Status | System Status |

### Kaleido-X Layout

You can enable or disable Kaleido-X integration in the [Advanced](#) configuration page. When it is enabled, a Kaleido-X button can be used to trigger a *re-layout* of the Kaleido-X multi-viewer. The two fields 'Kaleido-X Room' and 'Kaleido-X layout' are drop-down lists (unless you are working off-line) in which you may select a "room" and a layout for that room.

To configure a 'Kaleido-X Layout' button:

- 1 Click a button proxy.
- 2 Choose 'KaleidoX Layout' in the button type list.
- 3 Choose a "room" and then choose a layout for the room.
- 4 Optionally, change the button caption in the 'Mnemonic' field.

This is an example:

| Button | Type            | Mnemonic    | KaleidoX Room            | KaleidoX Layout   |
|--------|-----------------|-------------|--------------------------|---|
| 13     | KaleidoX Layout | Kx Layout 1 | ROOMX16                  | Layout 01.kg2   |
|        |                 |             | [Clear Entry]<br>ROOMX16 | [Clear Entry]<br>Layout 04.kg2<br>Layout 02.kg2<br>Layout 01.kg2<br>Layout 12.kg2<br>Layout 09.kg2<br>Layout 06.kg2<br>Layout 18.kg2<br>Layout 10.kg2 |

### Group Select

A 'Group Select' button places the sources of the source group associated with the button on the main source buttons. If a panel has more than one 'Group Select' button, they are mutually exclusive: The currently selected source group excludes other source groups from the panel buttons.

To configure a 'Group Select' button:

- 1 Click a button proxy.
- 2 Choose 'Group Select' in the button type list.

This is an example:

| Button | Type         | Mnemonic     | Group Number |
|--------|--------------|--------------|--------------|
| 4      | Group Select | GROUP SELECT | 1            |

You cannot change the button mnemonic. It is generated automatically. (Source groups are defined in MasterConfig.)

- ▲ Note that a 'Group Select' button becomes disabled (and dark) when a panel is **not** controlling an MCE configured with source groups.

## Flip-Flop

The 'Flip-Flop' button is a toggle that switches the panel between flip-flop mode and flip-only mode.

To configure a 'Flip-Flop' button:

- 1 Click a button proxy.
- 2 Choose 'FlipFlop' in the button type list.
- 3 Optionally, change the button caption in the 'Mnemonic' field.

This is an example:

| Button | Type      | Mnemonic  |
|--------|-----------|-----------|
| 4      | Flip Flop | Flip Flop |

- ▲ A panel configuration can have only one 'Flip-Flop' button.

## Bank Select

The MCPM architecture dictates that a control panel must have 16 main source buttons.

The SCP, iMC-Panel-100, iMC-Panel-200, CECP, CECP M1, CECP GUI, and the CFCP have 16 "virtual" main source buttons and up to 16 physical main source buttons. A bank select button allows the operator to switch between two subsets of the virtual buttons.

A bank select button is a toggle: pressed once, bank A sources appear on the physical main source buttons. Pressed again, bank B sources appear on the physical main source buttons.

Refer to [Button Assignments](#) on page 120 for information about defining the banks.

- ▲ Note that a 'Bank Select' button becomes disabled (and dark) when a panel is controlling an MCE configured with source groups.

To configure a 'Bank Select' button:

- 1 Click a button proxy.
- 2 Choose 'Bank Select' in the button type list.
- 3 Optionally, change the button caption in the 'Mnemonic' field.

This is an example:

| Button | Type        | Mnemonic    |
|--------|-------------|-------------|
| 4      | Bank Select | Bank Select |

## Emergency Bypass

MCPMs have an emergency bypass function controlled by a bypass relay. There are 2 emergency bypass (EB) button types that can be present on your panel.

## Emergency Bypass Status

An EB status button indicates the state of the emergency bypass relay of the currently selected MCPM.

To configure an 'EB Status' button:

- 1 Click a button proxy.
- 2 Choose 'EB Status' in the button type list.
- 3 Optionally, change the button caption in the 'Mnemonic' field.

This is an example:

| Button | Type      | Mnemonic  |
|--------|-----------|-----------|
| 1      | EB Status | EB Status |

## Emergency Bypass Control

An EB control button is a toggle that switches the EB relay of the currently selected MCPM.

To configure an 'EB Control' button:

- 1 Click a button proxy.
- 2 Choose 'EB Control' in the button type list.
- 3 Optionally, change the button caption in the 'Mnemonic' field.

This is an example:

| Button | Type       | Mnemonic   |
|--------|------------|------------|
| 2      | EB Control | EB Control |

## Transition Type

There are 9 'Transition Type' button functions:

|                        |                     |
|------------------------|---------------------|
| <b>Normal</b>          | <b>Preset black</b> |
| Cut                    | PB Cut (or cut/cut) |
| V-Fade (or fade-fade)  | PB Fade             |
| Fade-Cut               | PB Fade-Cut         |
| Cut-Fade               | PB Cut-Fade         |
| X-Fade (or cross fade) |                     |

Transition type buttons are mutually exclusive.

To configure a 'Transition Type' button:

- 1 Click a button proxy.
- 2 Choose one of the 9 transition types in the button type list.

For the SCP, iMC-Panel-100, iMC-Panel-200, iMC-Panel-300, CECP, CECP M1, and CECP GUI, you cannot change the 'Mnemonic' field because a transition button displays graphics, not text.

For the CFCP and FFCP, these buttons display text and you can edit the 'Mnemonic' field.

This is an example:

| Button | Type       | Mnemonic   |
|--------|------------|------------|
| 5      | PB CutFade | PB CutFade |

- ▲ The Aux/Preview GUI does not have transition type buttons.

## Transition Rate

There are 3 'Transition Rate' button types:

- 1 Slow.
- 2 Medium.
- 3 Fast.

Transition rate buttons are mutually exclusive.

To configure a 'Transition Rate' button:

- 1 Click a button proxy.
- 2 Choose one of the 3 transition rates in the button type list.
- 3 Optionally, change the button caption in the 'Mnemonic' field.

This is an example:

| Button | Type   | Mnemonic |
|--------|--------|----------|
| 7      | Medium | Medium   |

- ▲ The Aux/Preview GUI does not have transition rate buttons.

## Breakaway

The two types of breakaway buttons are:

- 1 Video Only.
- 2 Audio Only.

To configure a breakaway button:

- 1 Click a button proxy.
- 2 Choose either 'Video Only' or 'Audio Only' in the button type list.
- 3 Optionally, change the button caption in the 'Mnemonic' field.

This is an example:

| Button | Type       | Mnemonic   |
|--------|------------|------------|
| 7      | Video Only | Video Only |

- ▲ A panel configuration can have only one of each of the breakaway buttons.
- ▲ The Aux/Preview GUI does not have breakaway buttons.

## 'Dim' Buttons

Each of an MCPM's audio monitors, A and B, have a "dim" function associated with its audio level. Two "dim" buttons are available: 'Dim A' for monitor A and 'Dim B' for monitor B.

A "dim" button is a toggle that reduces or restores the audio level by an amount configured in the MCPM, typically 20 dB.

To configure a 'Dim' button:



- 1 Click a button proxy.
- 2 Choose either 'Dim A' or 'Dim B', as you require, in the button type list.
- 3 Optionally, change the button caption in the 'Mnemonic' field.

This is an example:

| Button | Type  | Mnemonic |
|--------|-------|----------|
| 1      | Dim A | DIM A    |

## Dolby E Backup Audio

Most MCPMs support Dolby E decoding as an option. An MCPM that has a Dolby E main source can also have a backup audio source.

Pressing a Dolby E *control* button switches a Dolby E main source to its backup source. (This is called "forced backup audio.") A Dolby E *status* button indicates when a Dolby source is switched to backup (forced or not). Pressing a Dolby E status button has no effect.

- ▲ Forced backup is useful in a situation where, because the Dolby E signal is good, the MCPM does not failover to backup audio, but the Dolby E contains silence and the operator wants to force a failover to backup audio.

In general, there are 6 Dolby E button types, covering status and control, for main sources on the program bus and on the preset bus:

|                     |                    |                     |
|---------------------|--------------------|---------------------|
| Program FBA Status  | Preset FBA Status  | Preview FBA Status  |
| Program FBA Control | Preset FBA Control | Preview FBA Control |

However, the Aux/Preview GUI has only 2: preview FBA status and preview FBA control.

- ▲ Preview is enabled only when a panel is controlling an MCE.
- ▲ The SCP, FFCP, and CFCP do not have preview functions.

## Dolby E Status

A Dolby E *status* button indicates whether a Dolby E main source is switched to backup.

To configure a Dolby E status button:

- 1 Click a button proxy.
- 2 Choose either 'Pgm FBA Status', 'Pst FBA Status', or 'Pvw FBA Status' in the button type list.
- 3 Optionally, change the button caption in the 'Mnemonic' field.

This is an example:

| Button | Type           | Mnemonic       |
|--------|----------------|----------------|
| 14     | Pvw FBA Status | PVW FBA Status |

## Dolby E Control

This button is a toggle that either forces the main source to its backup audio or reverts the main source to its Dolby E audio.

The Dolby E control button *also* displays status. A separate status button would not be required if you have a control button.

To configure a Dolby E control button:

## Button Functions (for MCEs and MCPMs)

### Button Functions (for MCEs and MCPMs)

---

- 1 Click a button proxy.
- 2 Choose either 'Pgm FBA Control', 'Pst FBA Control', or 'Pvw FBA Control' in the button type list.
- 3 Optionally, change the button caption in the 'Mnemonic' field.

This is an example:

| Button | Type            | Mnemonic        |
|--------|-----------------|-----------------|
| 16     | Pst FBA Control | PST FBA Control |

- ▲ These Dolby E functions are supported by MCPM software versions 4.5.0 and later.
- ▲ Presently, Dolby E buttons are not supported for the audio overs.

## Audio Macros

An audio macro button (available for CECP, CECP M1, CECP GUI, FECP, iMC-Panel-100, iMC-Panel-200, iMC-Panel-300, iMC-Panel-GUI, and Aux/Preview GUI configurations) changes the "mix" in the audio crosspoint matrix. You may define up to 16 macros.

You must define a macro before assigning to a button. See [Audio Macros](#) on page 129.

To configure an audio macro button:

- 1 Click a button proxy.
- 2 Choose one of the macros under 'Audio Macros' in the button type list.
- 3 Optionally, change the button caption in the 'Mnemonic' field.

This is an example:

| Button | Type        | Mnemonic |
|--------|-------------|----------|
| 3      | Audio Macro | Demo1    |

## Live Levels

A Live Level button (available only for CECP M1 configurations) directs either metering input A or metering input B to the Live Levels display.

To configure a Dolby E status button:

- 1 Click a button proxy.
- 2 Choose 'Live Levels A/B' in the button type list.
- 3 Optionally, change the button caption in the 'Mnemonic' field.
- 4 Select 'Input A' or 'Input B' in the drop-down list.

This is an example:

| Button | Type            | Mnemonic     | Live Levels A/B |
|--------|-----------------|--------------|-----------------|
| 1      | Live Levels A/B | Live Level A | Meter A         |

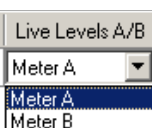

## Audio

These audio buttons apply only to the SCP. Other panels use the touchscreen and knobs (or GUI equivalents) to perform these audio functions.

An MCPM has two audio monitor outputs, A and B, and a metering output. The SCP has menu buttons that affect those outputs.

An MCPM mixes main source audio with over audio at a certain ratio. The audio can be controlled on the preset bus and the program bus. The SCP has menu buttons that allow an operator to control the audio levels and the mixing ratio.

There are 9 audio functions:

|                      |                      |                 |
|----------------------|----------------------|-----------------|
| Monitor A            | Monitor B            | Meters          |
| PST Main Audio Level | PST Over Audio Level | PST Audio Ratio |
| PGM Main Audio Level | PGM Over Audio Level | PGM Audio Ratio |

## Monitors A and B

When the operator presses a monitor button, a monitor menu appears. That menu contains PST, PGM, off-air, and aux buttons, a 'Dim' button, and a button that displays the monitor's audio gain (level). The monitor level adjustment knob is enabled. This is an example of the monitor A menu:



▲ The level button is **not** a meter.

To configure a monitor button:

- 1 Click a button proxy.
- 2 Find and choose 'Monitor A' or 'Monitor B' in the button type list.
- 3 Optionally, change the button caption in the 'Mnemonic' field.

This is an example:

| Button | Type      | Mnemonic  |
|--------|-----------|-----------|
| 2      | Monitor A | Monitor A |

## Meters

When the operator presses a meters button, a meter menu appears. That menu contains PST, PGM, off-air, and aux buttons, like the monitor menus, but does not have a dim or level button.

To configure a 'Meters' button:

- 1 Click a button proxy.
- 2 Find and choose 'Meters' in the button type list.
- 3 Optionally, change the button caption in the 'Mnemonic' field.

This is an example:

| Button | Type   | Mnemonic |
|--------|--------|----------|
| 2      | Meters | Meters   |

## Audio Level and Ratio

▲ These buttons are available for the SCP only.

Audio level (gain) and over-to-main ratio are miniature displays, not control buttons. Pressing them does nothing. There are 6 such buttons:

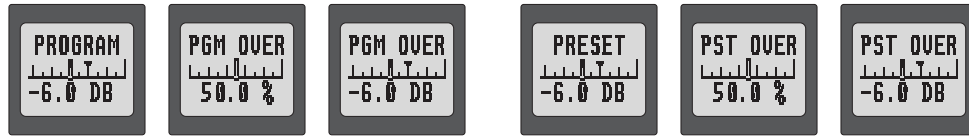

From left to right, above, they are

PGM Main Audio Level      PGM Over Audio Ratio      PGM Over Audio Level  
 PST Main Audio Level      PST Over Audio Ratio      PST Over Audio Level

Operators adjust audio gain and ratio using the 3 red audio level knobs at the right of the SCP.

▲ These buttons are **not** meters.

Audio gain adjusts from -108 to +12 dB in 0.5 dB steps generally. (Below -100 dB, the step is 1.0 dB.) Over-to-main ratio adjusts from 0 to 100% in steps of 0.5%. The over-to-main ratio is non-linear. A ratio of 50% means 100% main and 100% over. A value of 100% means 100% over source and 0% main source.

The buttons do not show the complete range.

▲ An operator can distinguish a ratio button because it is graduated in percent values.

▲ There are up to 8 channels of audio for a main source and for an over source. An audio level button shows only the level of channel 1.

To configure an audio level button:

- 1 Click a button proxy.
- 2 Choose one of the 6 audio adjustment buttons in the button type list.
- 3 Optionally, change the button caption in the 'Mnemonic' field. (Because the lower 2/3 of the button display graphics, the button caption is restricted to 8 characters.)

This is an example:

| Button | Type                 | Mnemonic |
|--------|----------------------|----------|
| 2      | Pst Main Audio Level | Preset   |

## Video Effects

Video effect buttons apply only to the SCP. Other panels use the touchscreen and knobs (or GUI equivalents) to perform video effect functions.

An MCPM can perform up to 6 layered video effects, in this order:

Key<sup>1</sup> 1, Logo A, Squeezeback, Keyer 2, Keyer 3, Logo B

Some MCPMs do not provide squeezeback or logo A. The MCPM-SDHD can perform enhanced squeezeback.

The SCP has 6 video effect selection buttons:

1. A "key" is a video effect comprising a video "fill" source and a "key" source. A "keyer" is a module within the MCPM that mixes the key sources into the program or preset output.

|                |                |                |
|----------------|----------------|----------------|
| Squeeze Select | Logo A Select  | Logo B Select  |
| Keyer 1 Select | Keyer 2 Select | Keyer 3 Select |

When the operator presses a 'Squeeze Select' button, the SCP presents a scrollable list of squeeze effects on the menu. The operator selects the effect by pressing the button displaying its name.

When the operator presses any of the keyer selection buttons, the SCP presents a scrollable list of keyer effects on the menu. Keyer effects are shared by all 3 keyers.

When the operator presses either of the logo selection buttons, the SCP presents a scrollable list of logo effects on the menu. Logo effects are shared by both logo inserters.

- ▲ If the SCP is controlling an MCPM that does not support squeezeback or logo A, those selection buttons, if present, are disabled (dark).
- ▲ Using an SCP, an operator can select, but cannot modify, a video effect. Using other panels, an operator can change all video effect parameters (e.g., logo opacity).

To configure a video effect button:

- 1 Click a button proxy.
- 2 Find and choose one of the 6 video effect buttons in the button type list.
- 3 Optionally, change the button caption in the 'Mnemonic' field.

This is an example:

| Button | Type           | Mnemonic       |
|--------|----------------|----------------|
| 2      | Squeeze Select | Squeeze Select |

## Dynamic Source Buttons

The MCPM supports source-to-button mapping, where an operator (or automation) can assign any of up to 128 main sources to a main source button during operation. Similarly, an operator (or automation) can assign any of up to 4 over sources to an over button.

Miranda's master control system also supports router pre-select, where an operator (or automation) can assign any of the router sources identified in a panel configuration to a main source button or to an over button.

Dynamic source buttons apply only to the SCP. Other panels use the touchscreen and knobs (or GUI equivalents) to perform dynamic button assignments.

There are 3 dynamic button types:

- Preset Main Button Map
 

When the operator presses this button, the SCP presents a scrollable main source list on the menu. The operator picks a source which is then assigned to the source button selected on the preset bus.
- Preset Over Button Map
 

When the operator presses this button, the SCP presents an over source list on the menu. The operator picks a source which is then assigned to the over button selected on the preset bus.

(If no over button is selected, this button is disabled.)
- Preset Main Router

## Button Functions (for MCEs and MCPMs)

### Button Functions (for MCEs and MCPMs)

---

When the operator presses this button, the SCP presents a scrollable *router category list* on the menu. The operator picks a category after which the SCP presents a scrollable *device list* for the category selected. The operator then picks a device which is then assigned to the main source button selected on the preset bus.

▲ 'Preset Over Router' is not implemented.

To configure a dynamic source button:

- 1 Click a button proxy.
- 2 Find and choose one of the 3 video effect buttons in the 'Utility' section of the button type list:
- 3 Preset Main Button MapPreset Over Button MapPreset Main Router
- 4 Optionally, change the button caption in the 'Mnemonic' field.

This is an example:

| Button | Type                   | Mnemonic         |
|--------|------------------------|------------------|
| 2      | Preset Over Button Map | Pst Over Btn Map |

## Menu Buttons

There are two distinct kinds of menu buttons:

- Menu navigation buttons for the SCP (only).
- Menu selection buttons for the iMC panels.

### Menu Selection Buttons

(These buttons apply to the iMC-Panel-100, iMC-Panel-200, iMC-Panel-300, and iMC-Panel-GUI.)

Menu selection buttons cause the menu associated with the button to appear on the panel's screen. There are 19 buttons in the set of menu buttons:

|                        |                                 |                        |
|------------------------|---------------------------------|------------------------|
| Main Menu              | Channel Select Menu             | Channel Edit/More Menu |
| PGM Audio Main Menu    | PST Audio Main Menu             | PVW Audio Main Menu    |
| PGM Audio Main Details | PST Audio Main Details          | PVW Audio Main Details |
| PGM Audio Over Details | PST Audio Over Details          | PVW Audio Over Details |
| PGM Audio Swap Menu    | PST Audio Swap Menu             | PVW Audio Swap Menu    |
| Source Groups Menu     | Video Effects Menu <sup>1</sup> | View Log Menu          |
| Live Audio Levels Menu |                                 |                        |

The 'Password Unlock' menu is an unusual case and *there is no button that invokes this menu*. If your panel is password-protected, this menu appears when the panel starts up. The menu expects an operator to press the numeric buttons on the screen to enter the password. If the operator does that successfully, the panel becomes usable.

The panel operator must press a 'Panel Lock' button to reinstate password protection. The panel lock button thus has two functions: to lock the panel entirely, requiring a press of the panel lock button to unlock it, and also to lock the menus.

---

1. This menu presents audio over controls as well.

When the panel resumes after being locked, the 'Panel Unlock' menu is presented again. However, the menu lock does not prevent access to all menus. The 'Live Levels' menu and the channel selection menu are two menus that can be used even when the menus are locked.

### Menu Navigation Buttons for the SCP

Menu navigation buttons apply only to the SCP. Other panels do not need this kind of navigation button. Other than the top level menu and panel menu, all menus are customer-defined. To configure a menu navigation button:

- 1 Click a button proxy.
- 2 Find and choose one of the menus named in 'Menus' section of the button type list.
- 3 Optionally, change the button caption in the 'Mnemonic' field.

This is an example:

| Button | Type | Mnemonic |
|--------|------|----------|
| 2      | Menu | DEMO     |

The menu's name is listed in the button type list. The menu's mnemonic (defined in the [User Menu Lists](#) configuration page) appears on the actual button.

▲ These buttons (and the [User Menu Lists](#) page) are not present only in a SCP configuration.

### Machine Control

Machine control buttons are available only on the CECP, CECP M1, CECP GUI, FECP, iMC-Panel-100, iMC-Panel-200, iMC-Panel-300, iMC-Panel-GUI, and SCP. The FFCP and CFCP do not support machine control.

There are 10 machine control button functions.

Play    Fast Forward    Cue    Preroll    Ready  
Stop    Rewind            Pause    Abort    Mark

- Play  
The 'Play' button starts normal-speed forward motion of the device represented by the (video) main source on the preset bus.
- Stop  
The 'Stop' button stops any motion of the tape and might have one or more side effects such as placing the VTR either in a ready or in a not-ready state or producing a still video frame. The side effects vary from device to device.
- Fast Forward  
The 'Fast Forward' button starts fast-speed forward motion of the tape.
- Rewind  
The 'Rewind' button starts reverse motion of the tape.
- Cue  
The 'Cue' button positions the tape either at its "pre-roll point" or at its "mark point." Whether it uses the pre-roll point or the mark point is configured in MasterConfig.

## Button Functions (for MCEs and MCPMs)

### Button Functions (for MCEs and MCPMs)

---

- **Pause**  
The 'Pause' button stops any motion of the tape and might have one or more side effects such as placing the VTR either in a ready or in a not-ready state or producing a still video frame. The side effects vary from device to device.
- **Preroll**  
The 'Preroll' button starts a transition with pre-roll.
- **Abort**  
The 'Abort' button cancels a transition started with pre-roll.
- **Ready**  
The 'Ready' button causes the device represented by the (video) main source selected on the preset bus to enter or re-enter the ready state.
- **Mark**  
The 'Mark' button causes the MCE to identify the current position of the device represented by the (video) main source selected on the preset bus as its "mark point" or "in point." The cue button positions the device relative to the mark point.

To configure any machine control button:

- 1 Click a button proxy.
- 2 Find and choose a function in the 'Machine Control' section of the button type list:
- 3 Optionally, change the button caption in the 'Mnemonic' field.

This is an example:

| Button | Type    | Mnemonic |
|--------|---------|----------|
| 1      | Preroll | PREROLL  |

The menu's name is listed in the button type list. The menu's mnemonic (defined in the [User Menu Lists](#) configuration page) appears on the actual button.

## XG Keyer Control

There is just one XG keyer control button. It is available only on the CECF, CECF M1, CECF GUI, FECF, iMC-Panel-100, iMC-Panel-200, iMC-Panel-300, and iMC-Panel-GUI. Its function is to remove an XG key from a transition immediately. (The XG key continues to play; it is just no longer visible.)

To configure an XG keyer control button:

- 1 Click a button proxy.
- 2 Find and choose the 'XG Keyers Control' buttons in the 'Utility' section of the button type list:
- 3 Optionally, change the button caption in the 'Mnemonic' field.

This is an example:

| Button | Type              | Mnemonic          |
|--------|-------------------|-------------------|
| 2      | XG Keyers Control | XG Keyers Control |

Normally the operator would use the 'XG Layer' buttons to turn layers on or off individually. The 'XG Keyer Control' button provides a way to turn all the keyer inputs from the Intuition XG on or off, regardless of which keyer layers are on. In practice, this should not be necessary. It is



intended only to provide the operator full control over the master control keyers which have been assigned to the Intuition XG. In an emergency, for example, if a network cable becomes disconnected and it is not possible to turn off the Intuition XG keyer layers, this button would allow the operator to hide all the keyer layers manually.

## Aux Delegates

Pressing a delegate button changes the function of the aux source buttons.

Normally aux delegate functions are placed on the aux bus. They can also be placed among the configurable buttons.

Aux delegates apply to the CECP, CECP M1, CECP GUI, FECP, iMC-Panel-100, iMC-Panel-200, iMC-Panel-300, iMC-Panel-GUI, and the Aux/Preview GUI.

In the Aux/Preview GUI, you can define up to 4 aux delegate buttons:

|           |                            |
|-----------|----------------------------|
| Aux A bus | Preview squeeze background |
| Aux B bus | Preview squeeze image 2    |

In the other panels, you can define up to 6 aux delegate buttons:

|           |                           |                            |
|-----------|---------------------------|----------------------------|
| Aux A bus | Preset squeeze background | Preview squeeze background |
| Aux B bus | Preset squeeze image 2    | Preview squeeze image 2    |

To configure an aux delegate button:

- 1 Click a button proxy.
- 2 Find and choose an aux delegate button in the 'Aux Delegate' section of the button type list:
- 3 Optionally, change the button caption in the 'Mnemonic' field.

This is an example:

| Button | Type                 | Mnemonic     |
|--------|----------------------|--------------|
| 2      | Preview Squeeze Bkgd | PVW SQZ BKGD |



# Operation (for Imagestore 750s)



Chapter 7 provides information about using the tabbed configuration pages—for panels when they are controlling Imagestore 750s—in the configuration editor’s work area.

## Topics

|                                      |     |
|--------------------------------------|-----|
| <i>New Configurations</i> .....      | 158 |
| <i>General</i> .....                 | 159 |
| <i>Channel Selection List</i> .....  | 160 |
| <i>User Button Layout</i> .....      | 163 |
| <i>Bottom Row Layout</i> .....       | 164 |
| <i>Logging Settings</i> .....        | 165 |
| <i>Advanced</i> .....                | 166 |
| <i>NV9000 Settings</i> .....         | 171 |
| <i>Button Assignments</i> .....      | 172 |
| <i>Audio Monitoring Layout</i> ..... | 174 |
| <i>Aux Row</i> .....                 | 175 |
| <i>Preview/User Row</i> .....        | 176 |
| <i>Monitor Wall</i> .....            | 177 |

(See chapter 5 on page 103 for information about configuring panels for use with MCEs and MCPMs.)

The panels that support Imagestore 750s are the iMC-Panel-100, iMC-Panel-200, iMC-Panel-GUI, and the iMC-Panel-300. This chapter does not discuss other panel types.

The iMC master control system includes the LGK-3901, DSK-3901, and ISM-3901. These are transition processors that fit in a 3RU Densité frames. The Master Control system treats these as if they were Imagestore 750s. These units are configured using the Imagestore 750 Configurator and each of the units has a browser application that is similar to the one provided by the Imagestore 750.

Some button functions and some Imagestore 750 functions might not be available to panels controlling these units because they offer a subset of the Imagestore 750’s functions.

## New Configurations

When you create a new configuration, the configuration editor asks you for a control panel type:

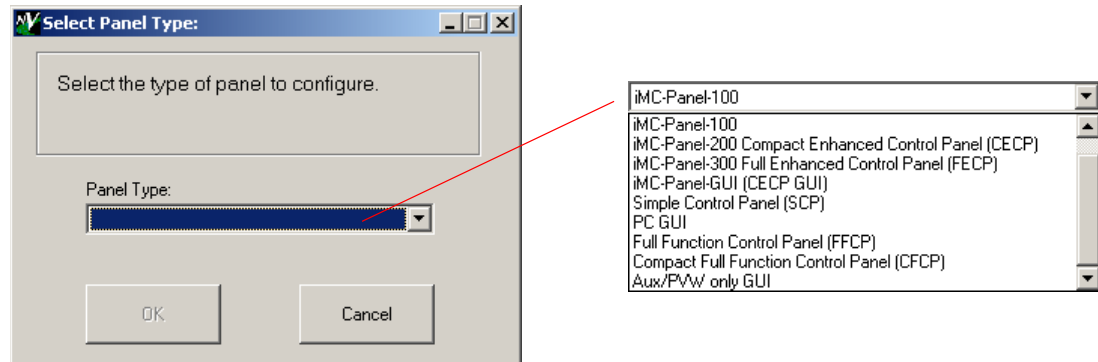

There are 8 choices in the drop-down menu. After you choose a control panel class, the configuration is locked to that control panel class. (There might be more than one panel type in the class.)

There are 4 panels that can control Imagestore 750s: the iMC-Panel-100, iMC-Panel-200, the iMC-Panel-300, and the iMC-Panel-GUI. Therefore your choices from this list should be:

- iMC-Panel-200 Compact Enhanced Control Panel (CECP)
- iMC-Panel-300 Full Enhanced Control Panel (FECP)
- iMC-Panel-GUI (CECP GUI)
- iMC-Panel-100 Rack-Mount Control Panel

(If you choose 'iMC-Panel-200 Compact Enhanced Control Panel (CECP)', there is an additional option that lets you configure an CECP M1. The CECP M1 cannot control an Imagestore 750.)

You will see a different set of configuration pages depending on the type of control panel you want to configure.

The panels that support Imagestore 750s allow a variable number of main source buttons and arbitrary ordering of DVE, DSK, and voice-over buttons. See the [Button Assignments](#) page.

The panels that support Imagestore 750s have aux buttons, so the configuration editor provides an [Aux Row](#) page for these panels. (See page 175.)

The preview/user buttons of panels when they are controlling Imagestore 750s are customer-configurable buttons, so the configuration editor provides an [Preview/User Row](#) page for these panels. (See page 176.)

The iMC-Panel-300 has a configurable monitor/meter section, so the configuration editor provides an [Audio Monitoring Layout](#) page for the iMC-Panel-300. (See page 174.) Note that this section is primarily a set of configurable buttons and has little to do with audio monitoring.

The content of a configuration page might vary slightly for different panels. For instance, the layout of the "bottom row" of an iMC-Panel-300 is different from the "bottom row" of a iMC-Panel-200.

## General

The 'General' page allows you to enter (or change) the control panel's name:

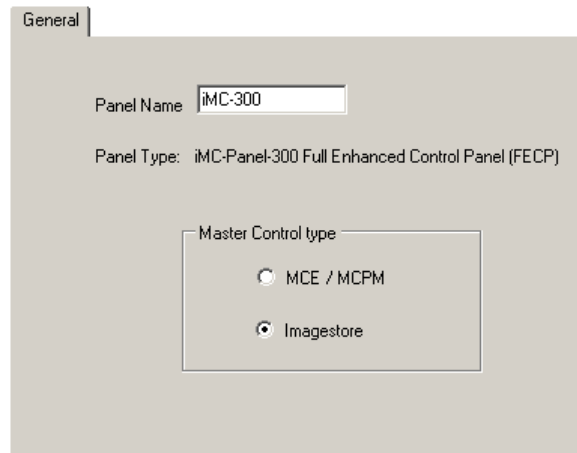

The screenshot shows a configuration window with a 'General' tab. It contains the following fields and options:

- Panel Name:** A text input field containing the value 'iMC-300'.
- Panel Type:** A text label showing 'iMC-Panel-300 Full Enhanced Control Panel (FECP)'.
- Master Control type:** A section containing two radio button options:
  - MCE / MCPM
  - Imagestore

Fig. 7-1: General Page (Sample)

We recommend that you use the default name, but it is possible for you to enter a name of your choosing. Do not use a space in the panel name. The configuration editor will accept it, but the space might cause problems on your master control network.

For the panels that support Imagestore 750s, you can select the set of configuration pages with which you wish to work. Select either 'MCE/MCPM' or 'Imagestore' at any time. If the panel is to control MCEs, MCPMs, and Imagestore 750s, do not neglect one or the other set of configuration pages.

When you choose 'New' in the 'File' menu, you are asked for a panel type. After you have chosen a panel type, the configuration is "locked" to that panel type. The 'General' page reports the panel type.

The 'General' page appears when you start a new configuration, open an existing configuration, read a configuration from a panel, and, of course, when you click the 'General' tab itself.

## Channel Selection List

Use the 'Channel Selection List' page to specify what channels (i.e., Imagestore 750s) the control panel may access:

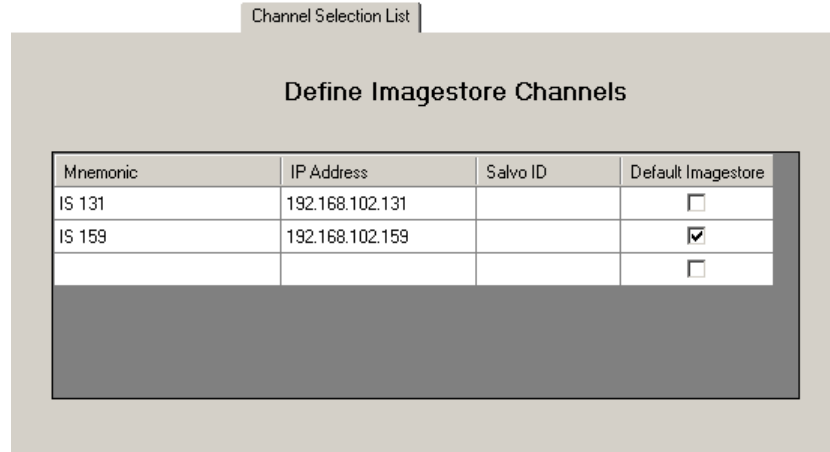

The page contains a table of channels. The table uses one row to represent each MCPM or MCE. Each row includes a channel name, the IP address of the channel, and checkbox to indicated whether the table entry is the default channel. The default channel is the one that is selected when the panel restarts.

Note that there is a *different* 'Channel Selection List' page for MCEs and MCPMs. Keep in mind these points:

- 1 IP addresses for *all* of your channels, regardless of type, must be unique.
- 2 A panel may have at most one default channel. If you designate a channel as the default in the Imagestore pages, any default you selected in the MCE/MCPM pages will be cleared. Similarly, if you designate a channel as the default in the MCE/MCPM pages, any default you selected in the Imagestore pages will be cleared.

## Automation Focussing

Automation Focussing is where the automation system can select a channel.

When 'Enable Automation Focussing' is checked in the [Advanced](#) configuration page, an additional column —'ShotBox ID'— appears in the channel selection table:

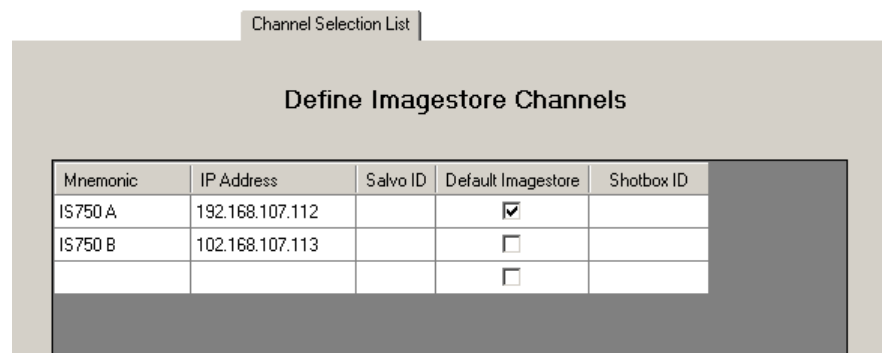

Automation identifies channels by "shotbox ID." When automation selects a channel, it sends a "shotbox" ID to the control panel(s) in the master control system. If a control panel has automation focussing enabled, it looks up the channel by its "shotbox ID" and attaches that channel. If your system uses shotbox IDs, you, the configurer, must obtain the IDs and enter them in the 'Shotbox ID' column.

## Kaleido X Integration

Kaleido-X integration is enabled or disabled in the [Advanced](#) configuration page. When it is enabled, a channel change can trigger a *re-layout* of the Kaleido-X multi-viewer, and two additional fields appear in the channel list: 'Kaleido-X Room' and 'Kaleido-X layout':

Channel Selection List

**Define Imagestore Channels**

| Mnemonic | IP Address      | Salvo ID | Default Imagestore                  | KaleidoX Room | KaleidoX Layout |
|----------|-----------------|----------|-------------------------------------|---------------|-----------------|
| IS750 A  | 192.168.107.112 |          | <input checked="" type="checkbox"/> | ROOMX16       | Layout 02.kg2   |
| IS750 B  | 102.168.107.113 |          | <input type="checkbox"/>            | ROOMX16       | Layout 04.kg2   |
|          |                 |          | <input type="checkbox"/>            | ROOMX16       | Layout 09.kg2   |

These fields are drop-down lists (unless you are working off-line) in which you may select a "room" and a layout for that room. You can do this for each channel that is to trigger a re-layout when an operator selects the channel.

## Channel Thumbnails

▲ Thumbnails are available only for the iMC-Panel-100.

If you are editing an iMC-Panel-100 configuration, the 'Channel Selection List' page has an extra column—a 'Bitmap' column:

Channel Selection List

**Define Imagestore Channels**

| Mnemonic ▲ | IP Address      | Salvo ID | Default Imagestore                  | Bitmap                                      |
|------------|-----------------|----------|-------------------------------------|---|
| IS 131     | 192.168.102.131 |          | <input checked="" type="checkbox"/> | C:\Program Files\Miranda\M...\Jellyfish.bmp |
| IS 159     | 192.168.102.159 |          | <input type="checkbox"/>            | C:\Program Files\Mir...\Chrysanthemum.bmp   |
| TST 9      | 10.96.196.9     |          | <input type="checkbox"/>            | C:\Program Files\Miranda\Ma...\Desert.bmp   |
| UK 30      | 10.96.188.30    |          | <input type="checkbox"/>            | C:\Program Files\Mir...\GUI_screenshot.bmp  |
| UK 31      | 10.96.188.31    |          | <input type="checkbox"/>            | C:\Program Files\Mirand...\Hydrangeas.bmp   |
| UK 32      | 10.96.188.32    |          | <input type="checkbox"/>            | C:\Program Files\Mirand...\Pat_the_cat.bmp  |
| UK 33      | 10.96.188.33    |          | <input type="checkbox"/>            | C:\Program Files\Miranda\M...\Jellyfish.bmp |
| UK 34      | 10.96.188.34    |          | <input type="checkbox"/>            | C:\Program Files\Miranda\...\Penguins.bmp   |
| UK 35      | 10.96.188.35    |          | <input type="checkbox"/>            |   |
|            |                 |          | <input type="checkbox"/>            |   |

Channel buttons in the top row of the display of an iMC-Panel-100 can show thumbnail images representing the channels. (Channel buttons in positions other than the top row do not show thumbnail images.)

In the 'Bitmap' column, you can specify the pathname of a bitmap (.bmp) file for the channel button. Click the field for a channel to change its pathname. A navigation dialog appears in which you can select a bitmap file.

▲ Although you can select a different file at any time, it is not possible to clear the field once you have entered a pathname.

Channel thumbnails are arbitrary graphics. The graphics files must be 128 × 96 pixels in size, with 24-bit color. The panel editor accepts only .bmp files. It does not accept .jpg, .tif, or .png, or any other format.

(There are 8 buttons in the top row of the display.)

## Usage

You can tab through the entries in the table or click directly on an entry to edit or clear the entry. Entering data in any field of the *bottom* row has the side effect of creating a new empty row.

It is permissible to have entries in this table that do not correspond to actual channels.

Follow these steps to add a channel to this list:

- 1 Enter the IP address of the Imagestore 750 in the IP address column.
- 2 Enter a channel name in the 'Mnemonic' column. That name will appear in the channel selection menu and on buttons of the panel. (Mnemonics are limited to 8 characters.)



3 If you wish to associate an NV9000 salvo with the channel, select it in the Salvo ID column. The selected salvo will execute when the operator selects the channel.

To be able to select a salvo, you must have an NV9000 router control system connected to your master control network. (Refer to the NV9000 documentation for information on salvos.) You must also have checked 'Attach to NV9000' in the [NV9000 Settings](#) page.

If you do not have an NV9000 connected (and attached), you may enter a salvo ID manually in the 'Salvo ID' field. It will help to have a list of salvos and their IDs handy.

After making all the entries you want, take this additional step: mark one of the channels as the default channel.

The channels appear in the control panel's channel list—in the 'Channel Select' menu—in the order you enter them here.

If you make a configurable button a 'Channel' button, the configuration editor presents the channel list you define here as choices for the button you are defining. You cannot create a 'channel' button unless the channel is defined on this configuration page.

## User Button Layout

This is the 'User Button Layout' page:

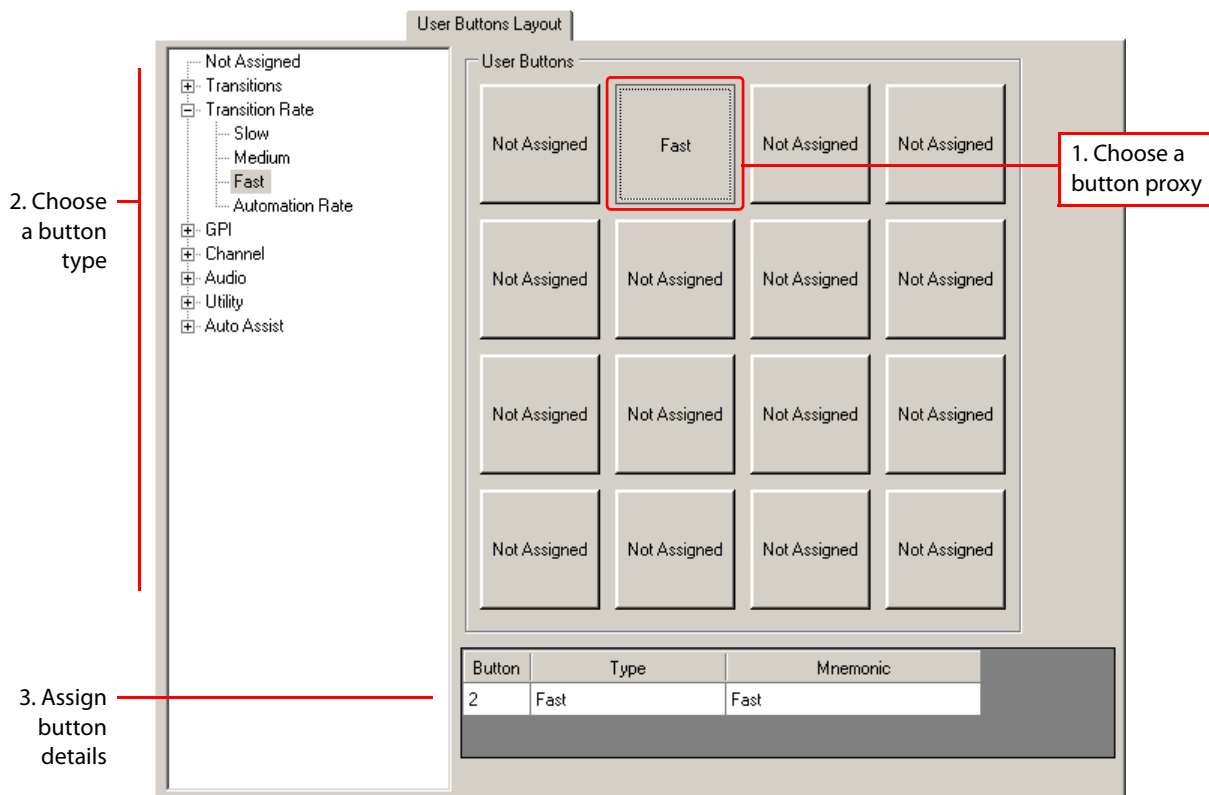

Fig. 7-2: User Button Layout Page (Sample, iMC-Panel-GUI)

Select the 'User Button Layout' page to assign functions to the 16 buttons in the configurable button section of the panel. By default, no buttons are assigned.

To assign a function to a button, first click the button proxy of your choice, then select a button type in the list on the right.

When you have chosen a button type, assign values to the button fields of the table row at the bottom of the page. The button fields in the table row vary with the button type.

In most cases, you can override the button's default mnemonic.

Refer to Chapter 8, [Button Functions \(for Imagestore 750s\)](#), for a description of the button types and their associated fields.

## Bottom Row Layout

This is the 'Bottom Row Layout' page:

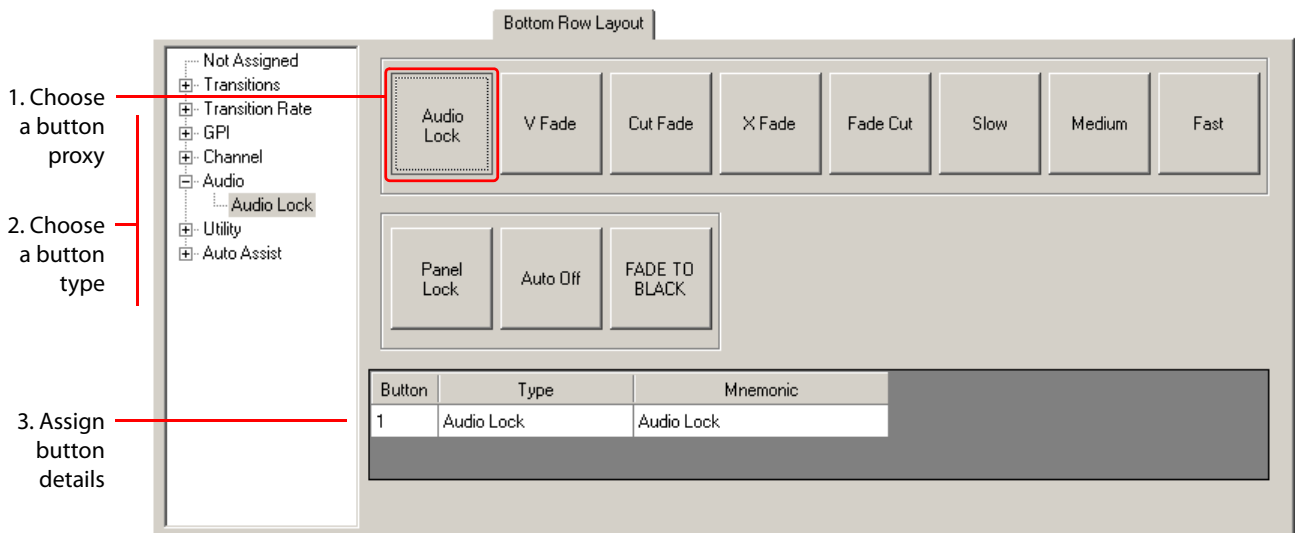

Fig. 7-3: Bottom Row Layout Page (Sample, iMC-Panel-GUI)

All panels have some number of configurable buttons at the front and left of the panel (or at the bottom and left, in the case of GUI and the iMC-Panel-100). These are assigned transition control functions and system control functions by convention. The 'Bottom Row' configuration page lets you assign functions to these buttons. The number of buttons in the row differ for different panel models.

To assign a function to a button, first click the button proxy of your choice, then select a button type in the list at the bottom of the page.

When you have chosen a button type, assign values to the button fields of the table row in the middle of the page. The button fields in the table row vary with the button type.

In most cases, you can override the button's default mnemonic.

Refer to Chapter 8, [Button Functions \(for Imagestore 750s\)](#), for a description of the button types and their associated fields.

## Logging Settings

This is the 'Logging Settings' page:

The screenshot shows the 'Logging Settings' page with the following configuration:

- Update Connection: Errors
- Command Connection: Errors
- Configuration: System Events
- NV9000 System: Errors
- Oxtel Protocol: Errors
- Panel Only:
  - Panel Switchboards: Errors
  - Panel Serial Comm: Errors
  - Panel Hardware: Errors
  - User Action: Errors

Fig. 7-4: Logging Settings Page (Sample)

Use this page to set the level of event reporting for several event classes. The levels for each class are the same and are selectable through pull-down lists. There are 7 levels of reporting:

|               |   |
|---------------|---|
| None          | No error logging is performed.  |
| Errors        | Only critical system errors are logged.   |
| Warnings      | Only warnings and errors are logged.  |
| System events | The activities in the 2 previous levels, plus system events.  |
| Transactions  | The activities in the 3 previous levels, plus a record of all messages between all system components. |
| All events    | All system activity.  |
| Debug         | Information about errors. (Use this option under Miranda direction.)                                  |

The event log is kept within the panel. To examine the log, choose 'Read Log from Panel...' from the 'Tools' menu. In the dialog that follows, save the log in your PC's file system. The log is a text file that you can open in Windows NotePad or a similar program.

For the GUI, the log is kept in a hidden temporary file. To retrieve the log, first save the log from the GUI. The resulting file is always C:\log.txt. Copy that file to some other location and open it with NotePad, Word, or a similar application.

## Advanced

The 'Advanced' page configures some of the more obscure panel features.

The 'Advanced' pages for different panels are slightly different. The fields for the 'Advanced' page are described, starting on page 167.

This is an example of the 'Advanced' page for iMC-Panel-200s and iMC-Panel-300s:

Fig. 7-5: Advanced Settings Page (iMC-Panel-200, iMC-Panel-300)

The page for iMC-Panel-200s and iMC-Panel-300s provides a panel brightness setting. (These panels have a built-in LCD.)

The page for iMC-Panel-100s and iMC-Panel-GUIs provides a 'Hide Mouse Cursor' option. (The default for iMC-Panel-100s, which is presumed to have a touchscreen, is to hide the mouse cursor. The default for the iMC-Panel-GUI is to show the mouse cursor. The GUI is presumed to run on a PC.)

Figure 7-6, next page, shows the page for iMC-Panel-100s and iMC-Panel-GUIs.

This is the 'Advanced' page as it might be for iMC-Panel-100s and iMC-Panel-GUIs:

Fig. 7-6: Advanced Settings Page (iMC-Panel-100, iMC-Panel-GUI)

## Kaleido-X Integration

Master control can be integrated with a Kaleido-X multi-viewer (or monitor wall) in such a way that master control can trigger a Kaleido-X *re-layout*. The Kaleido system defines *rooms* (in which a multi-viewer exists) and *layouts* (the organization of views on the multi-viewer) for each room. Panel operators can have available buttons that trigger multi-viewer re-layout. A channel change can also trigger a multi-viewer re-layout.

The option in the Advanced configuration page (1) enables Kaleido-X integration and (2) specifies the IP address of the Kaleido-X multi-viewer.

When Kaleido-X integration is enabled, the 'Channel Selection List' page shows two additional fields: 'Kaleido-X Room' and 'Kaleido-X Layout'. You can specify the Kaleido-X room and layout for the that will take effect when the panel switches to that channel. See [Channel Selection List](#) on page 160.

When Kaleido-X integration is enabled, a 'Kaleido-X Layout' button shows drop-down lists for its 'Kaleido-X Room' and 'Kaleido-X Layout' fields. See [Kaleido-X Layout](#) on page 190.

## Source Groups

The Imagestore 750 configuration allows the definition of different groups of sources (which in the master control system are taken from the NV9000 configuration). The master control system allows panel operators to select different source groups.

If you check the 'Enable Global Source Groups' option, when the panel operator selects a source group, all panels controlling the same Imagestore 750 switch to that source group.

If you leave the option unchecked, the change in source group affects only the panel at which it was made.

For more information, see the [Group Select](#) button on page 186.

## Panel LCD Brightness

Enter a value from 0 to 255 in the brightness field. A value of 255 results in full brightness. An operator can change the brightness value from 40 to 255.

(A GUI configuration does not have an LCD brightness option.)

## Automation

### Enable Automation Focussing

Automation focussing (for Oxtel automation) is where the automation system can select a channel. If you enable it by placing a check in the check box, your automation system can select channels.

When this option is checked, an additional column — 'Shotbox ID' — appears in the table on the [Channel Selection List](#) configuration page. You must enter those IDs.

Thus, when automation selects a channel, it sends the "shotbox ID" to the panel. The panel looks up the channel by its "shotbox ID" and switches the channel accordingly.

### Enable iTX Integration

This option allows the panel to perform automation focussing under an iTX system.

When you place a check in the check box for this option, and additional field appears in the 'Advanced' page:

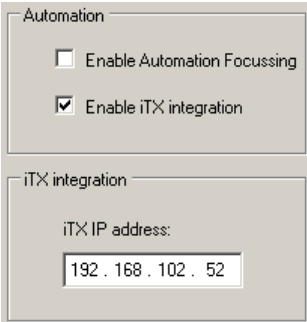

The image shows a configuration window with two sections. The top section is titled 'Automation' and contains two checkboxes: 'Enable Automation Focussing' (unchecked) and 'Enable iTX integration' (checked). The bottom section is titled 'iTX integration' and contains a label 'iTX IP address:' followed by a text input field containing the IP address '192 . 168 . 102 . 52'.

Enter the IP address of the iTX system in that field. Automation focussing for the specified iTX is enabled.

▲ Note that the two check box options are mutually exclusive.

## Initially Arm as Fade

DSK buttons and voice-over buttons on the panel have 3 states: cut, fade, and off. Operators can select one of those 3 states by repeatedly pressing the button.

When you check this option, the buttons' state order is (1) fade, (2) cut, (3) off.

When you leave this option unchecked, the order is (1) cut, (2) fade, (3) off.

## Always Show Source

If you enable this option by checking the checkbox, additional options appear:

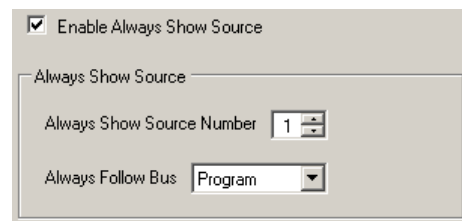

When this option is enabled, automation when selecting a source that is not present on one of the panel's main source buttons will use one of the buttons to "show the source."

You can specify the button to use for this by scrolling through the numbers in the 'Always Show Source Number' list.

Specify either 'Program' or 'Preset' in the 'Always Follow Bus' drop-down menu. A typical configuration would have 'Preset' selected.

## Channel Acquisition

You can specify whether the panel you are configuring can share a channel with other panels.

If you want your panel to share, check the 'Allow Sharing' checkbox.

If your panel must not share, do not check the 'Allow Sharing' checkbox.

You can further how your panel behaves when it does not share. "Kicking" means preemption.

The 'Allow Kicking' option specifies how this panel reacts to preemption by another panel:

- Never—this panel will never be preempted.
- By panels of higher priority.
- By panels of the same or higher priority.
- Always—this panel will always be preempted.

Finally, you can specify the priority of this panel. The priority value range is from 1 (the lowest priority) to 255 (the highest).

If the operator attempts to kick (preempt) another panel, he or she will get an alert message asking for confirmation of the intention to do so.

## Enable Traditional PST Tally

Some operators like “PresStation” method of arming DVEs, DSKs, and voice-overs on the preset bus. Other operators like the traditional method (which is used for MCEs and MCPMs).

If you check the ‘Enable Traditional PST Tally’ checkbox, the panel will operate using the traditional method. Otherwise, the panel will use the “PresStation” method.

If you check the ‘Enable Traditional PST Tally’ checkbox, it is imperative that the ‘Active Preview Keyers’ parameter of the Imagestore 750 configuration be set to true. In addition, if the panel you are configuring uses DVEs, set the ‘Active Preview DVE’ parameter of the Imagestore 750 configuration to true. Refer to the *Imagestore 750 Reference Manual* for details.

## PGM Selected Source Color

You can specify the color for *selected* main sources on the program bus. Your choices in the drop-down list are:

- ‘Normal’—selected sources are high-tally green (unless they are LOS or non-sync).
- ‘Alternate White’—selected sources are white (unless they are LOS or non-sync)
- ‘Alternate Red’—selected sources are red (unless they are LOS or non-sync)
- ‘Alternate Yellow’—selected sources are yellow (unless they are LOS or non-sync)

## PGM Unselected Source Color

You can specify the color for *unselected* main sources on the program bus. Your choices in the drop-down list are:

- ‘Normal’—selected sources are high-tally green (unless they are LOS or non-sync).
- ‘Alternate White’—selected sources are white (unless they are LOS or non-sync)
- ‘Alternate Red’—selected sources are red (unless they are LOS or non-sync)
- ‘Alternate Yellow’—selected sources are yellow (unless they are LOS or non-sync)

## PST Selected Source Color

You can specify the color for *selected* main sources on the preset bus. Your choices in the drop-down list are:

- ‘Normal’—selected sources are high-tally green (unless they are LOS or non-sync).
- ‘Alternate White’—selected sources are white (unless they are LOS or non-sync)
- ‘Alternate Red’—selected sources are red (unless they are LOS or non-sync)
- ‘Alternate Yellow’—selected sources are yellow (unless they are LOS or non-sync)

## PGM Unselected Source Color

You can specify the color for *unselected* main sources on the preset bus. Your choices in the drop-down list are:

- ‘Normal’—selected sources are high-tally green (unless they are LOS or non-sync).
- ‘Alternate White’—selected sources are white (unless they are LOS or non-sync)
- ‘Alternate Red’—selected sources are red (unless they are LOS or non-sync)
- ‘Alternate Yellow’—selected sources are yellow (unless they are LOS or non-sync)



## 'Automation Off' Button Color

With this option, you can designate how the 'Automation Off' button functions. These are your choices:

- 'Normal' (low-tally green when automation is on, high-tally red when automation is off).
- 'Reverse' (high-tally red when automation is on, low-tally green when automation is off).

The 'Reverse' option is essentially a warning that automation is on and operators must exercise caution **not** to use the panel.

## NV9000 Settings

This is the 'NV9000 Settings' page:

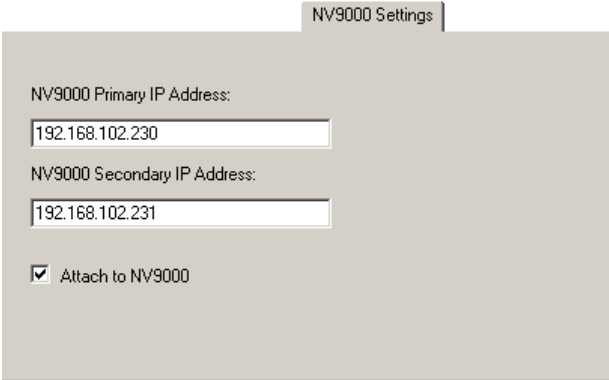

The screenshot shows a web interface for 'NV9000 Settings'. It contains two text input fields for IP addresses. The first field is labeled 'NV9000 Primary IP Address:' and contains the value '192.168.102.230'. The second field is labeled 'NV9000 Secondary IP Address:' and contains the value '192.168.102.231'. Below these fields is a checked checkbox labeled 'Attach to NV9000'.

Fig. 7-7: NV9000 Settings Page (Sample)

If your master control system is connected to an NV9000 router control system, you should designate its IP address(es) here. You should also check the 'Attach to NV9000' check box. Doing this makes it easier to use other configuration pages, such as the 'Monitor Wall' page.

## Button Assignments

This is the 'Button Assignments' page as it might appear for a iMC-Panel-200:

| Button    | Function    | Bank A Source |
|-----------|-------------|---------------|
| Button 1  | Main Source | 1             |
| Button 2  | Main Source | 2             |
| Button 3  | Main Source | 3             |
| Button 4  | Main Source | 4             |
| Button 5  | Main Source | 5             |
| Button 6  | Main Source | 6             |
| Button 7  | Main Source | 7             |
| Button 8  | Main Source | 8             |
| Button 9  | Main Source | 9             |
| Button 10 | DVE 1       | ▼             |
| Button 11 | DSK 1       | ▼             |
| Button 12 | DSK 2       | ▼             |
| Button 13 | DSK 3       | ▼             |
| Button 14 | DSK 4       | ▼             |
| Button 15 | VO 1        | ▼             |
| Button 16 | VO 2        | ▼             |

Fig. 7-8: Button Assignments Page (Sample, iMC-Panel-200)

Each panel that supports Imagestore 750s has a variable number of main source buttons, DVE buttons, DSK buttons, and voice-over buttons. This is the page in which to specify the number of such buttons and to distribute those button functions on the program, preset, and aux buttons of the panel.

The number of main source buttons can vary from 0 to 16.

Up to 4 DVE buttons, 4 DSK buttons, 2 voice-over buttons, and 8 XG keyer layer buttons can be defined, subject to the number of main source buttons and the number of buttons in the row. (The Imagestore 750 must include the DVE option if the DVE button is to function properly.)

If the IS750 does not have a DVE unit, DVE buttons are disabled.

All main sources must be contiguous on the left side of the button rows. All effects buttons are to the right of the main sources but they need not be contiguous and they need not be in any particular order.

However, the effects always execute in the order defined by the Imagestore 750 configuration.

Your panel need not have any effects buttons. The default setting, however, includes all DSKs and both voice-overs, and no DVE. You might want to remove an effect from the button rows if you do not use it.

## Main Source Button Qty

To change the number of main source buttons, check the 'Enable—Changes..' box in the 'Main Source Button Qty' section. Then enter the number of main sources in the scroll box in that section. You can use the tiny scroll arrows to select the number desired or you can type it directly.

When you have chosen the number of main sources, you can uncheck the 'Enable' box to prevent accidentally changes.

## The Button Table

The button table has 16 or 24 rows representing the 16 or 24 buttons of the panel. (The aux buttons include the same source buttons as the other button rows, but include no effects buttons.)

Follow these guidelines to define the button table.

- 1 Before changing the button definitions in the button table, choose the number of physical main sources you will be using in this configuration.
- 2 Double-click entries in the 'Bank A Source' column and re-enter the values there so that the physical buttons get the source numbers of your choice.

▲ The term "Bank A" has no meaning for Imagestore 750s.

The sources are selected as "channel sources" in the Imagestore 750 Configurator. What you enter in the 'Bank A Source' column are the source IDs that form the indices of the various source groups.

If for example, the Imagestore 750 configuration has 3 source groups having 8, 10, and 12 sources, respectively, and your panel has 10 main source buttons, you would enter the numbers 1–10, typically in numerical order.

When the operator chooses the 8-entry source group, the last two main source buttons are unused.

When the operator chooses the 12-entry source group, the last two sources in the group do not appear on buttons (and are unusable).

It is possible to permute the ordering of sources if you have a reason to do so.

The sources that actually appear on the physical main source buttons belong to the currently selected source group. Source groups are defined in the Imagestore 750 configuration and are selectable with [Group Select](#) buttons.

▲ For related information, see the global source group option under the [Advanced](#) configuration page.

The entries in the 'Bank A Source' column may be blank. The only stipulation is that you cannot duplicate entries.

- 3 Assign or unassign any of the effects on the buttons below the main sources in the button table.

Double-click the 'Function' column field in the effect's table row. A drop-down list appears:

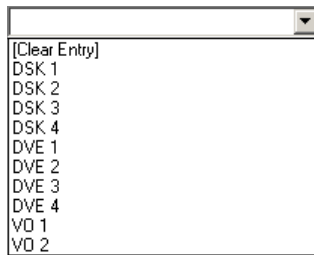

Effects that have already been assigned do not appear in the list. If all effects have been assigned, the list is empty.

Choose '[Clear Entry]' to remove an effect assigned to that particular physical button. Choose any of the other entries to assign that effect or over to the physical button.

There can be no duplication. If you want to assign an effect to a button and it is already assigned to another button, you must first remove the assignment from the other button.

## Audio Monitoring Layout

- ▲ This configuration page applies only to the iMC-Panel-300. The configuration editor does not display this page for configurations of other panel types.

This is the 'Audio Monitoring Layout' configuration page:

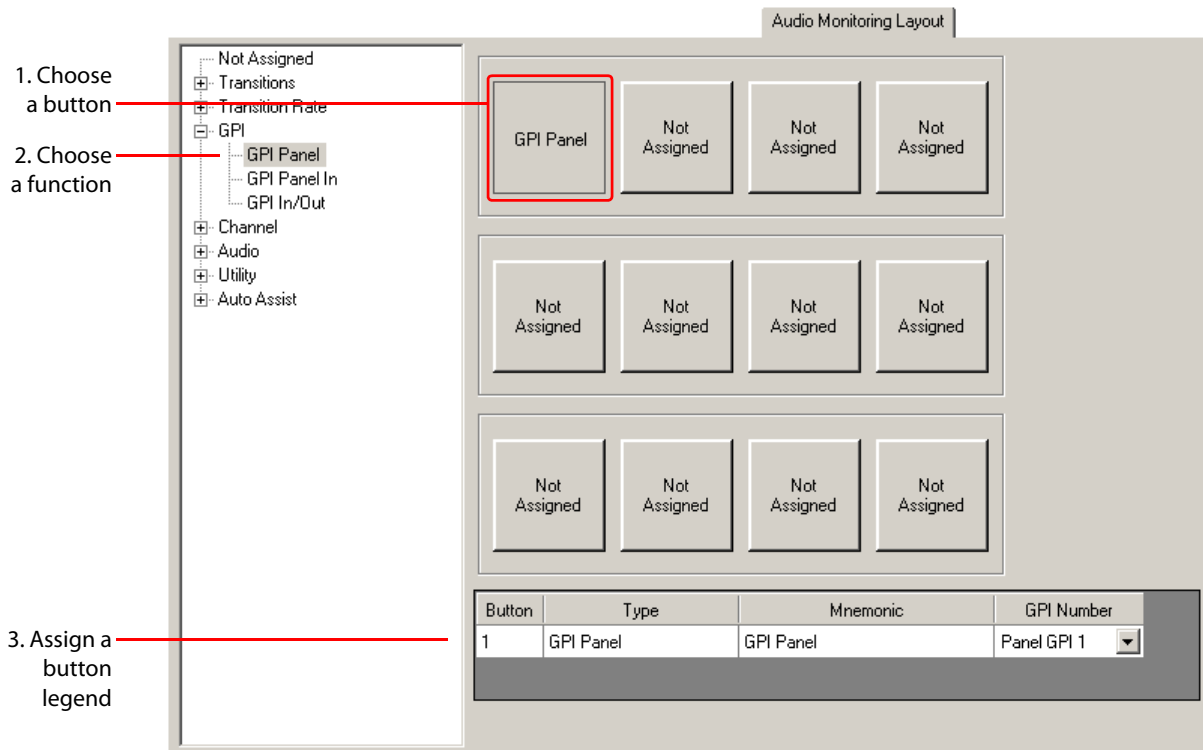

Fig. 7-9: Audio Monitoring Layout Page (Default, iMC-Panel-300)

The name 'Audio Monitoring Layout' page is potentially confusing. The buttons have nothing in particular to do with audio monitoring—they are simply configurable buttons. The name of this page stems from the fact that the buttons are in the "Audio Monitoring" section of the iMC-Panel-300.

To assign a function to a button, first click the button proxy of your choice, then select a button type in the list at the bottom of the page.

When you have chosen a button type, you can change the button legend as you want. Its mnemonic can be whatever you want (up to 24 characters). It should make sense to the panel operator.

You can configure any of these buttons as 'Not Assigned' in which case the button has no function and will remain dark.

Refer to Chapter 8, [Button Functions \(for Imagestore 750s\)](#), for a description of the button types and their associated fields.

## Aux Row

This is the 'Aux Row' configuration page:

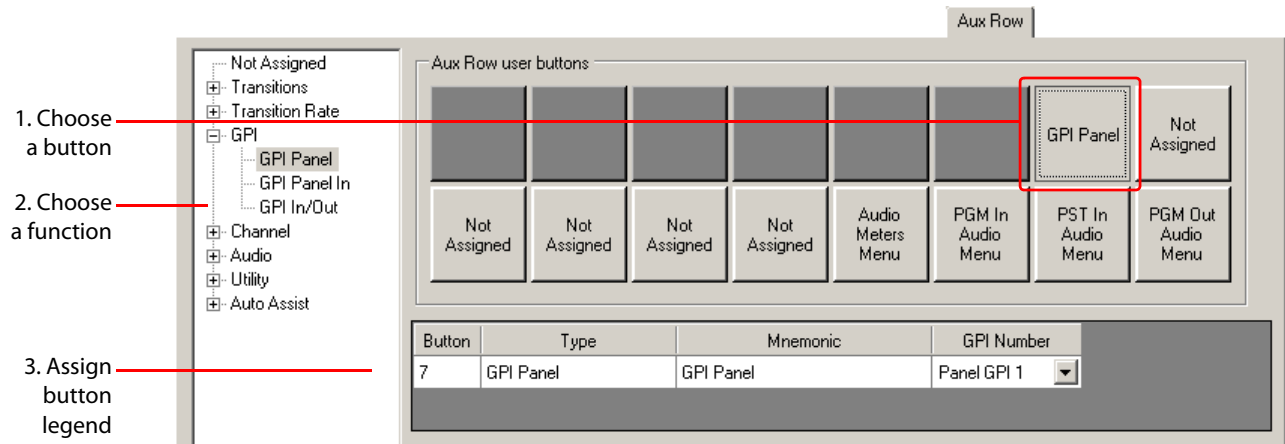

Fig. 7-10: Aux Row Page (iMC-Panel-200)

The aux/user button row contains main sources and customer-definable buttons. The main sources are identical to the main sources of the program and preset buttons rows. Main source buttons are allocated and defined in the [Button Assignments](#) configuration page.

The 'Aux Row' page lets you assign functions to the customer-definable buttons.

The number of configurable buttons available in the aux row depends on the number of source buttons you have chosen (in the Button Assignments page). Aux button positions assigned to sources are represented in this configuration page as dark rectangles:



To assign a function to a button, first click the button proxy of your choice, then select a button type in the list at the bottom of the page.

When you have chosen a button type, you can change the button legend as you want. Its mnemonic can be whatever you want (up to 24 characters). It should make sense to the panel operator.

Figure 7-10 shows the default buttons for this page. (Other than 'Not Assigned', they are customer-configurable buttons.)

Refer to Chapter 8, [Button Functions \(for Imagestore 750s\)](#), for a description of the button types and their associated fields.

- ▲ The main sources that appear on the preset, program, and aux button rows are (1) selected from NV9000 sources in the Imagestore 750 Configurator (software) as “channel sources” and (2) entered in the [Button Assignments](#) page of the MCS Panel Configuration Editor.

Panel operators may select source groups using ‘Group Select’ buttons. When a source group is selected, the names of the main sources belonging to the group appear on the main source buttons.

## Preview/User Row

This is the ‘Preview/User Row’ configuration page:

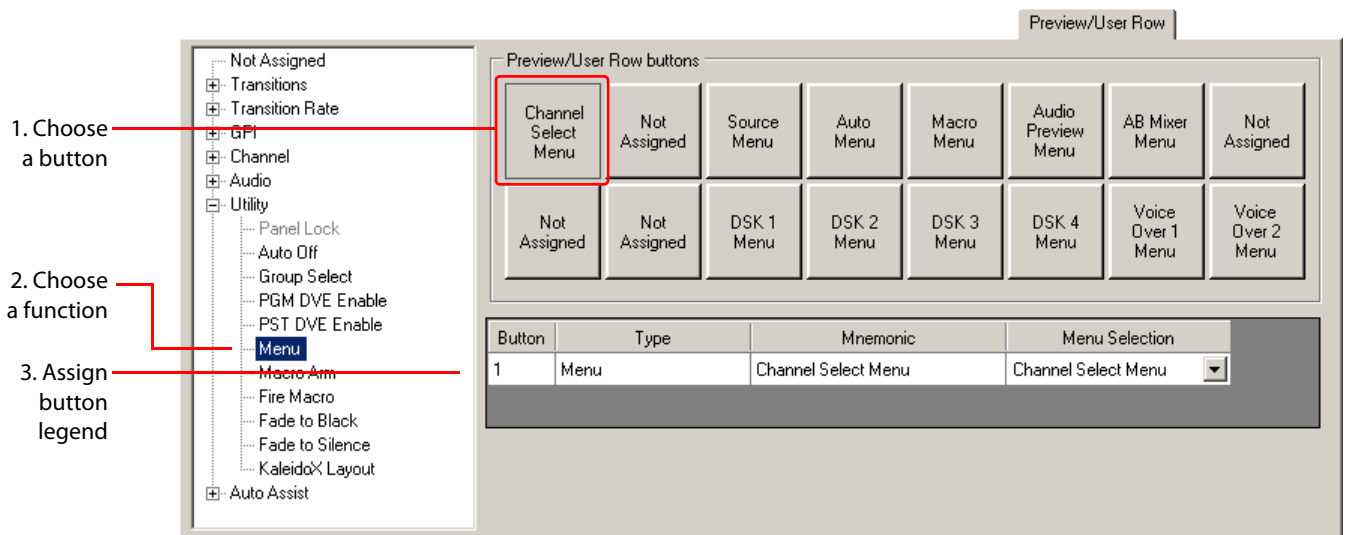

Fig. 7-11: Preview/User Row Page (Default, iMC-Panel-200)

Each of the buttons in the ‘Preview/User’ button row is configurable. It is in this configuration page that you can assign button functions to this button row.

To assign a function to a button, first click the button proxy of your choice, then select a button type in the list at the bottom of the page.

When you have chosen a button type, you can change the button legend as you want. Its mnemonic can be whatever you want (up to 24 characters). It should make sense to the panel operator.

Figure 7-11 shows the default buttons for this page. (Other than ‘Not Assigned’, they are customer-configurable buttons.)

Refer to Chapter 8, [Button Functions \(for Imagestore 750s\)](#), for a description of the button types and their associated fields.

## Monitor Wall

This is the 'Monitor Wall' configuration page:

Monitor Wall

For each Master Control channel, this panel can control router destinations on a monitor wall. The panel will automatically update the monitor wall with the channel's PGM/PST/CLN/AUX outputs, whenever that channel is acquired by this panel. In this table, enter the NV9000 Destination IDs of the monitor wall channel outputs. It is recommended to first attach to the NV9000 in the NV9000 Settings tab, in order to see the actual mnemonics of the NV9000 destination IDs.

For each main source xpt button, this panel can control a router destination on a monitor wall. The panel will automatically update the monitor wall with the main sources, whenever the source mapping of those xpt buttons is changed. In this table, enter the NV9000 Destination IDs of the monitor wall sources.

| Channel Output | NV9000 Dest ID   | Mnemonic |
|----------------|--|----------|
| Program        | 1148   | MONITR13 |
| Preset         | 1149   | MONITR14 |
| Cleanfeed      | 1150   | MONITR15 |
| Monitor        | MON 3:1074   | MON 3    |
| Aux            | MON 2:1073<br>MON 2:1115<br>MON 3:1074<br>MON 3:1116<br>MON 4:1075<br>MON 4:1117<br>MON1:51<br>MON2:52 | MONITR16 |

| Xpt Button | NV9000 Dest ID   | Mnemonic |
|------------|--|----------|
| 1          | 1136   | MONITOR1 |
| 2          | 1137   | MONITOR2 |
| 3          | 1138   | MONITOR3 |
| 4          | 1139   | MONITOR4 |
| 5          | 1140   | MONITOR5 |
| 6          | 1141   | MONITOR6 |
| 7          | 1142   | MONITOR7 |
| 8          | 1143   | MONITOR8 |
| 9          | 1144   | MONITOR9 |
| 10         | 1145   | MONITR10 |
| 11         | 1146   | MONITR11 |
| 12         | MONITR12:1147  | MONITR12 |
| 13         | MONITOR9:1144<br>MONITR10:1145<br>MONITR11:1146<br>MONITR12:1147 |          |
| 14         | MONITR13:1148  |          |
| 15         | MONITR14:1149  |          |
| 16         | MONITR15:1150<br>MONITR16:1151                                   |          |

Fig. 7-12: Monitor Wall Page (Default, iMC-Panel-200)

### Destinations for Imagestore 750 Sources

The panel can cause the NV9000 system to display the currently selected main sources on a Kaleido-X monitor wall.

The sources currently selected at the panel can change through an operator's button press, through a channel change, or through automation.

When the operator selects a source group (using a 'Group Select' button), the panel sends a request to Imagestore 750, which in turn sends a request to the NV9000 system to perform a take of the appropriate sources to the destinations that drive the monitor wall. The appropriate sources are those that are mapped to the main source buttons.

## Destinations for Imagestore 750 Outputs

The panel can also cause the NV9000 system to display the outputs (program, preset, clean-feed, etc.) of the currently selected Imagestore 750 on a Kaleido-X monitor wall.

It is in this page of the configuration editor that you specify the destinations that drive the monitor wall.

You can specify up to 5 NV9000 destinations in this table for Imagestore 750 *outputs*. Follow these steps:

- 1 In the column labeled 'NV9000 Dest ID', click the field next to the output you want to configure. A drop-down menu appears.
- 2 Scroll through the drop-down menu to find the destination that drives the intended Kaleido-X input. Click that destination.
- 3 The NV9000-SE Utilities destination ID appears in the 'NV9000 Dest ID' field and its mnemonic appears in the 'Mnemonic' field.

## Destinations for Imagestore 750 Sources

You can specify up to 24 NV9000 destinations in this table for Imagestore 750 *sources*. Entry 1 corresponds to the panel's first, or left-most, main source button. Entry 2 corresponds to the panel's next main source button, and so on.

- ▲ Because the panel accesses different source groups, the button can correspond to different sources. This configuration page maps *buttons* to monitor wall destinations.
- ▲ The 'Monitor Wall' page for iMC-Panel-300s has 24 entries in the table whereas the table for iMC-Panel-200s and iMC-Panel-GUIs have 16 entries.
- ▲ The default is an empty table.

Follow these steps:

- 1 In the column labeled 'NV9000 Dest ID', click the field next to the source button you want to configure. A drop-down menu appears.
- 2 Scroll through the drop-down menu to find the destination that drives the intended Kaleido-X input. Click that destination.
- 3 The NV9000-SE Utilities destination ID appears in the 'NV9000 Dest ID' field and its mnemonic appears in the 'Mnemonic' field.

## About Router Connections

For the monitor wall switching to work, the outputs of multiple Imagestore 750s are connected to router inputs. The router switches the inputs of the currently selected Imagestore 750 to the router destinations that you specified in this configuration page.

The router destinations you specify in this page are physically connected to the Kaleido-X multi-viewer.

The router inputs to which the Imagestore 750s connected are specified in the Imagestore 750 Configurator, for each Imagestore 750.

The sources used by the various Imagestore 750s are router sources. You also specify those sources in the Imagestore 750 Configurator.



This is a typical monitor wall connection for multiple Imagestore 750s. (The sources and outputs for the selected Imagestore 750 appear on the monitor wall:

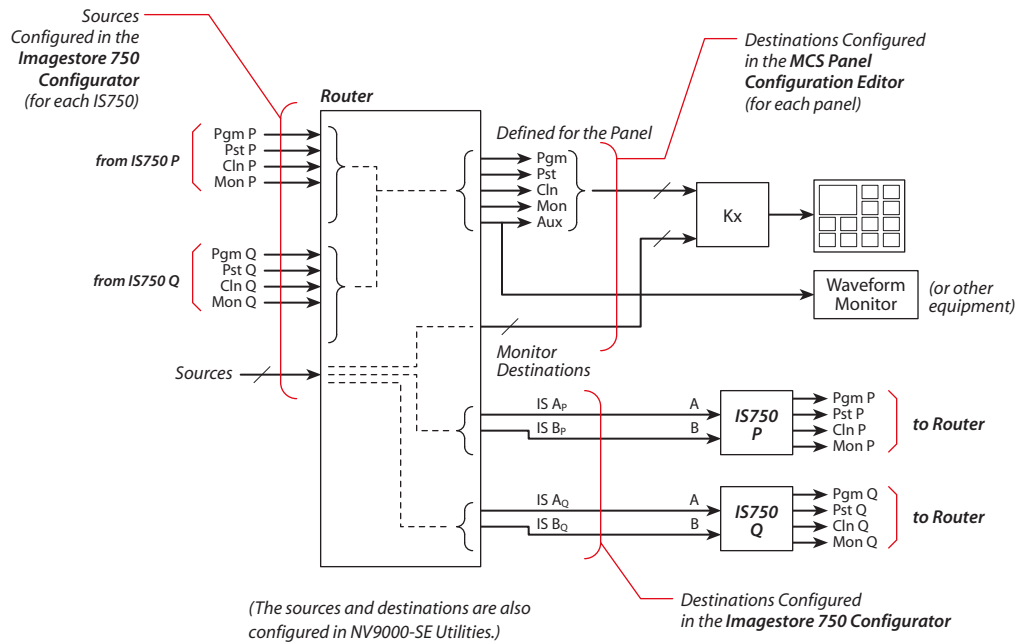

This is a typical monitor wall connection for a single Imagestore 750, where sharing is not at issue:

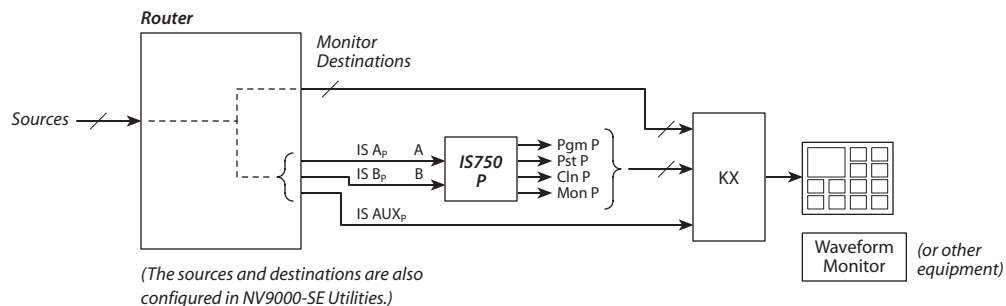

## Aux Connections

The aux output associated with an Imagestore 750 is a special case. First, it is not a part of the Imagestore 750, it is actually a router destination that is controlled by the Imagestore 750.

(The device connected to the aux destination “displays” whatever source the operator selected on the aux button row.)

Second, if you specify a monitor wall destination for aux output in the ‘Monitor Wall’ configuration page, that destination is used instead of the aux output defined for an individual Imagestore 750. That is to say, the Imagestore 750 switches aux outputs to that destination and all Imagestore 750s can share the monitor wall and the auxiliary device.

If you do not specify a monitor wall destination for aux output in the ‘Monitor Wall’ configuration page, the aux outputs for individual Imagestore 750s, if defined, are use. That is to say, the Imagestore 750 switches the aux outputs to its own destination.



# 8

## Button Functions (for Imagestore 750s)

Chapter 8 describes the configurable button types for panels when they are controlling Imagestore 750s.

### Topics

|  |     |
|--|-----|
| <a href="#">Summary</a> .....                    | 181 |
| <a href="#">Definable Button Functions</a> ..... | 182 |

The iMC master control system includes the LGK-3901, DSK-3901, and ISM-3901. These are transition processors that fit in a 3RU Densité frames. The Master Control system treats these as if they were Imagestore 750s. These units are configured using the Imagestore 750 Configurator and each of the units has a browser application that is similar to the one provided by the Imagestore 750.

Some button functions and some Imagestore 750 functions might not be available to panels controlling these units because they offer a subset of the Imagestore 750's functions.

(See chapter 6 on page 131 for information about button types for use with MCEs and MCPMs.)

### Summary

The MCS Panel Configuration Editor configures several control panels that can control Imagestore 750s: the iMC-Panel-100, iMC-Panel-200, iMC-Panel-300, and iMC-Panel-GUI.

When these panels are controlling Imagestore 750s, there is a set of button functions that applies to all configurable buttons. There are 33 functions. The functions are the same for each of the hardware panels. The iMC-Panel-GUI does not have GPI buttons or an 'Audio Lock' button.

All of these panels has several sets of configurable buttons. The configuration editor calls these:

- User buttons.
- Bottom row buttons.
- Top row buttons (for the iMC-Panel-100 only).
- Aux row buttons.
- Preview/user row buttons.
- Audio monitoring layout buttons (for the iMC-Panel-300 only).

## Definable Button Functions

These are the button types:

| Utility          | Channel                    | Transition type | Transition rate      |
|------------------|----------------------------|-----------------|----------------------|
| Panel Lock       | Channel [Select]           | Cut             | Slow                 |
| Auto[mation] Off | Salvo                      | V-fade          | Medium               |
| Group Select     | No Channels                | Cut fade        | Fast                 |
| Menu             | Gang Channels              | X-fade          | Automation rate      |
| Macro Arm        |                            | Fade cut        |                      |
| Fire Macro       | <b>Auto[mation] Assist</b> | U-fade          | <b>Audio</b>         |
| Fade to Black    | Cue Next                   | V-fade preset 1 | Audio Lock           |
| Fade to Silence  | Skip Next                  | V-fade preset 2 |                      |
| PGM DVE Enable   | Hold Next                  |                 | <b>GPI</b>           |
| PST DVE Enable   | Take Next                  | <b>Take</b>     | GPI Input            |
| Kaleido-X Layout |                            | Take Primary    | GPI Output           |
|                  |                            | Take Secondary  | GPI Input and Output |

Following are descriptions of the functions that can be assigned to buttons during configuration. In the following definitions, the term “proxy” means a square figure on the configuration page that represents a button and its current assignment. A blank proxy is an unassigned button.

A button that is designated ‘Not Assigned’ has no function. On the panel, the button’s legend is blank and the button light is off. (The panel can never enable or disable this kind of button.)

- ▲ Some button types (such as ‘Panel Lock’) become unavailable (and are displayed in gray) if they have already been assigned to a button (somewhere on the panel).
- ▲ Status buttons usually do nothing when pressed.

## Channel Functions

An Imagestore 750 is called a *channel*. A typical panel configuration provides a set of channel selection buttons. A channel can be configured to invoke an NV9000 salvo when selected.

There are 6 channels functions:

- Channel.
- Salvo.
- ‘No Channels’.
- ‘Gang Channels’.

### Channel

A ‘Channel’ button selects a channel. To configure a ‘Channel’ button:

- 1 Click a button proxy.
- 2 Find and choose ‘Channel’ in the button type list.
- 3 Choose one of the defined channels in the ‘Channel Selection’ drop-down list.  
The channels must have been defined in the [Channel Selection List](#) page.

- 4 The 'Mnemonic' field displays the channel name. You cannot modify this field. (However, you can change the channel name in the 'Channel Selection List' configuration page.)

This is an example:

| Button | Type    | Mnemonic | Channel Selection |
|--------|---------|----------|-------------------|
| 9      | Channel | IS750a   | 192.168.107.12    |
|        |         |          | 192.168.107.12    |
|        |         |          | 192.168.107.13    |

- ▲ Only one channel selection button may be assigned to a channel.

(On the CECP M1 only, a channel selection might be configured to switch the live levels display to metering input A or to metering input B.)

### No Channels

A 'No Channels' button quickly disconnects the panel from all MCPMs. (To restore operation, the operator selects any channel.)

To configure a 'No Channels' button:

- 1 Click a button proxy.
- 2 Choose 'No Channel' in the button type list.
- 3 Optionally, change the button caption in the 'Mnemonic' field.

This is an example:

| Button | Type        | Mnemonic    |
|--------|-------------|-------------|
| 9      | No Channels | No Channels |

### Salvo

A salvo button causes an Imagestore 750 salvo to execute, which in turn fires an NV9000 salvo.

- ▲ A channel change can execute an NV9000 salvo.

To configure a 'Salvo' button:

- 1 Click a button proxy.
- 2 Choose 'Salvo' in the 'Type' field.
- 3 Enter an Imagestore 750 salvo number (0, 1, 2 . . .).

This is an example:

| Button | Type  | Mnemonic | Salvo ID  |
|--------|-------|----------|---|
| 1      | Salvo | MCT 1080 | 5   |
|        |       |          | [Clear Entry]<br>DevName:3<br>MCT 1080:5<br>MCT 525:6<br>MCT 720p:4<br>Salvo2:2 |

Note that the salvo ID is defined in the Imagestore 750 and can change from one Imagestore 750 to another.

- ▲ It is in the salvo definition in the Imagestore 750 Configurator that you can specify an NV9000 salvo.

### Gang Channels

A 'Gang Channels' button lets an operator couple two or more channels. It is a toggle that enables or disables ganged operation. When channels are ganged, any action performed on the "main" channel is also performed on all selected "follower" channels.

To configure a 'Gang Channels' button:

- 1 Click a button proxy.
- 2 Choose 'Gang Channels' in the button type list.
- 3 Optionally, change the button caption in the 'Mnemonic' field.

This is an example:

| Button | Type          | Mnemonic      |
|--------|---------------|---------------|
| 2      | Gang Channels | Gang Channels |

- ▲ A panel operator can gang at most 4 channels.
- ▲ When gang selection is enabled, salvos assigned to channels are inhibited.
- ▲ Ganged channels must be either all Imagestore 750s or all MCEs and MCPMs.

### GPI

A hardware panel has a connector that provides 2 relay outputs and 2 optically isolated TTL-level inputs. These are called GPI (general-purpose interface) ports. The relays can control external devices. The inputs can sense external events in your system.

There are 3 GPI button types that can be present on a panel that is controlling an Imagestore 750:

---

|                               |   |
|-------------------------------|---|
| GPI panel input               | Displays status of one of the 2 inputs on the panel.  |
| GPI panel output              | Controls one of the 2 relays on the panel.            |
| Combined GPI input and output | Displays status of one input and controls one output. |

---

- ▲ A panel configuration does not allow any GPI port to be represented by more than one button.

### GPI Output

A GPI output button is a toggle: when it is deselected, the associated relay's "normally open" circuit is open. When it is selected, the button is high-tally and the relay's "normally open" circuit is closed.

To configure a panel GPI output button:

- 1 Click a button proxy.
- 2 Choose 'GPI-Panel' in the button type list.
- 3 Select a GPI output number in the 'GPI Number' drop-down list.
- 4 Enter a button caption in the 'Mnemonic' field.

This is an example:

| Button | Type      | Mnemonic  | GPI Number  |
|--------|-----------|-----------|---|
| 1      | GPI Panel | GPI Panel | Panel GPI 1  |

## GPI Input

A GPI input button displays the state of a GPI input. There are 2 options:



- 1 The button is high-tally when the GPI input is inactive (no current or “open” circuit).
- 2 The button is high-tally when the GPI input is active (current flowing or “closed” circuit).

To configure a panel GPI input button:

- 1 Click a button proxy.
- 2 Choose ‘GPI Panel In’ in the button type list.
- 3 Select a GPI input number in the ‘GPI Number’ drop-down list.
- 4 Enter a button caption in the ‘Mnemonic’ field.
- 5 Choose either ‘Open is Selected’ or ‘Closed is Selected’ in the ‘Sense’ drop-down list.

Here, the word “selected” means the button is high-tally. “Open is selected” corresponds to option 1 (mentioned above); “Closed is selected” corresponds to option 2.

This is an example:

| Button | Type         | Mnemonic     | GPI Number  | Sense  |
|--------|--------------|--------------|---|--|
| 1      | GPI Panel In | GPI Panel In | Panel GPI 1  | Open is Selected  |
|        |              |              |   | Not Specified  |
|        |              |              |   | Open is Selected   |
|        |              |              |   | Closed is Selected   |

## GPI Input and Output

A combined GPI input and output button performs 2 functions:

- The illumination of the button represents the state of a GPI input as for GPI input buttons.
- Pressing the button toggles the state of a relay, as for GPI output buttons. The button displays the state of the designated input (and not the designated output).

To configure a GPI input/output button:

- 1 Click a button proxy.
- 2 Choose ‘GPI In/Out’ in the button type list.
- 3 Enter a button caption in the ‘Mnemonic’ field.
- 4 Select a GPI input number in the ‘GPI In’ drop-down list.
- 5 Choose either ‘Open is Selected’ or ‘Closed is Selected’ in the ‘Sense’ drop-down list.

This applies to the GPI input. “Open is selected” means the button is high-tally when the input circuit is open; “Closed is selected” means the button is high-tally when the circuit is closed.

- 6 Select a GPI output number in the ‘GPI Out’ drop-down list.

## Button Functions (for Imagestore 750s)

### Definable Button Functions

This is an example:

| Button | Type       | Mnemonic   | GPI In      | Sense            | GPI Out     |
|--------|------------|------------|-------------|------------------|-------------|
| 1      | GPI In/Out | GPI In/Out | Panel GPI 1 | Open is Selected | Panel GPI 1 |

Dropdown menu for Sense:

- Not Specified
- Open is Selected
- Closed is Selected

## Utility Functions

There are 11 utility button *types* that can be present on a panel:

Panel Lock    Auto Off    Fade to Black    Macro Arm    PGM DVE Enable  
Menu    Group Select    Fade to Silence    Fire Macro    PST DVE Enable  
Kaleido-X Layout

### Panel Lock

The panel lock button prevents anyone from accidentally making changes at the panel.

A panel lock button is a toggle that locks or unlocks the panel.

To configure a 'Panel Lock' button:

- 1 Click a button proxy.
- 2 Choose 'Panel Lock' in the button type list.
- 3 Optionally, change the button caption in the 'Mnemonic' field.

This is an example:

| Button | Type       | Mnemonic   |
|--------|------------|------------|
| 10     | Panel Lock | Panel Lock |

### Auto Off

The 'Auto Off' button is a toggle that enables or disables control of the Imagestore 750 by automation.

To configure an 'Automation Off' button:

- 1 Click a button proxy.
- 2 Choose 'Auto Off' in button type list.
- 3 Optionally, change the button caption in the 'Mnemonic' field.

This is an example:

| Button | Type     | Mnemonic |
|--------|----------|----------|
| 9      | Auto Off | Auto Off |

### Group Select

A 'Group Select' button selects an Imagestore 750 source group.

A source group is a set of channel sources defined in the Imagestore 750 configuration. When the panel operator selects a source group, the names of the sources appear on the main source buttons of the preset, program, and aux button rows of the panel. Optionally, the selected



sources are displayed on a monitor wall. See the [Monitor Wall](#) configuration page for more information.

To configure a 'Group Select' button:

- 1 Click a button proxy.
- 2 Choose 'Group Select' in the button type list.
- 3 Optionally, change the button caption in the 'Mnemonic' field.
- 4 Specify the source group number. Obtain the group number from the Imagestore 750's configuration.

This is an example:

| Button | Type         | Mnemonic     | Group Number |
|--------|--------------|--------------|--------------|
| 9      | Group Select | GROUP SELECT | 4            |

## Menu

A 'Menu' button places a menu on the panel's touchscreen (or in the case of the GUI, on the menu area). A 'Menu' button toggles between the selected menu and the main menu.

To configure a 'Menu' button:

- 1 Click a button proxy.
- 2 Choose 'Menu' in the button type list.
- 3 Optionally, change the button caption in the 'Mnemonic' field.
- 4 Choose one of the 18 menus in the drop-down menu.

This is an example:

| Button | Type | Mnemonic  | Menu Selection  |
|--------|------|-----------|---|
| 13     | Menu | Main Menu | <div style="border: 1px solid black; padding: 2px;"> <div style="background-color: #e0e0e0; padding: 2px;">Main Menu ▾</div> <div style="padding: 2px;">Main Menu ▲</div> <div style="padding: 2px;">Source Menu</div> <div style="padding: 2px;">Auto Menu</div> <div style="padding: 2px;">A/B Mixer Menu</div> <div style="padding: 2px;">Macro Menu</div> <div style="padding: 2px;">XG Keyer Layers Menu</div> <div style="padding: 2px;">Channel Select Menu</div> <div style="padding: 2px;">PGM Out Audio Menu ▾</div> </div> |

These are the menus that you can select:

- Main menu.
- Source menu — allows the operator to choose a source group and to add, delete, or change sources in the group. (The selected source group becomes the active source group.)
- Auto[mation] — presents automation assist buttons ('Cue Next', 'Skip Next', 'Hold Next', 'Take Next', and 'Take'). See [Automation Assist](#) on page 192.
- A/B mixer menu — displays the down-time, mid-time, and up-time of the transition types and allows the operator to view and change the slow, medium, and fast transition rates.
- Macro menu — allows the operator either to arm a macro for execution at the next transition or to execute (fire) the macro immediately.
- XG keyer layer menu — allows the operator to select and control XG media and keyer layers.
- Channel select menu — allows the operator to select a channel.
- PGM out audio menu — controls for the Imagestore 750's program audio output.

## Button Functions (for Imagestore 750s)

### Definable Button Functions

---

- PGM in audio menu — controls for the Imagestore 750's program audio input.
- PST out audio menu — controls for the Imagestore 750's preset audio output.
- Audio meters menu — displays audio meters and allows the selection of metering input.
- Audio preview menu.
- DSK 1–4 menus — controls for the Imagestore 750's downstream keyers.
- Voice-over 1, 2 menus — controls for the Imagestore 750's voice-over audio.
- EasyPlay 1, 2 menus — allow the operator to select EasyPlay clips for voice-overs.

### Macro Arm

A 'Macro Arm' button arms a macro. This means that the macro will execute when the operator next presses the transition (take) button. There are certain macro functions that must not execute during a transition. If the macro contains such a function, it will execute immediately after the transition completes.

See Miranda's Imagestore 750 documentation regarding macros and how to define a macro.

To configure a 'Macro Arm' button:

- 1 Click a button proxy.
- 2 Choose 'Macro Arm' in the button type list.
- 3 Optionally, change the button caption in the 'Mnemonic' field.
- 4 Specify a macro number.

This is an example:

| Button | Type      | Mnemonic  | Macro Number |
|--------|-----------|-----------|--------------|
| 1      | Macro Arm | MACRO ARM | 0            |

### Fire Macro

A 'Fire Macro' button is a button that executes an Imagestore 750 macro immediately.

To configure a 'Fire Macro' button:

- 1 Click a button proxy.
- 2 Choose 'Fire Macro' in the button type list.
- 3 Optionally, change the button caption in the 'Mnemonic' field.
- 4 Specify a macro number.

This is an example:

| Button | Type       | Mnemonic   | Macro Number |
|--------|------------|------------|--------------|
| 1      | Fire Macro | FIRE MACRO | 0            |

See Miranda's Imagestore 750 documentation regarding macros and how to define a macro.

### Fade to Black

A 'Fade To Black' button is a toggle that fades the Imagestore 750's program output to, or from, both black and silence. To configure a 'Fade to Black' button:

- 1 Click a button proxy.
- 2 Choose 'Fade to Black' in the button type list.

3 Optionally, change the button caption in the 'Mnemonic' field.

This is an example:

| Button | Type          | Mnemonic      |
|--------|---------------|---------------|
| 9      | Fade to Black | FADE TO BLACK |

### Fade to Silence

A 'Fade To Silence' button is a toggle that fades the Imagestore 750's program output to, or from, silence. To configure a 'Fade to Silence' button:

- 1 Click a button proxy.
- 2 Choose 'Fade to Silence' in the button type list.
- 3 Optionally, change the button caption in the 'Mnemonic' field.

This is an example:

| Button | Type            | Mnemonic        |
|--------|-----------------|-----------------|
| 10     | Fade to Silence | FADE TO SILENCE |

### PGM DVE Enable

A 'PGM DVE Enable' button enables or disables DVE buttons on the program button row.

To configure a 'PGM DVE Enable' button:

- 1 Click a button proxy.
- 2 Choose 'PGM DVE Enable' in the button type list.
- 3 Optionally, change the button caption in the 'Mnemonic' field.

This is an example:

| Button | Type           | Mnemonic       |
|--------|----------------|----------------|
| 1      | PGM DVE Enable | PGM DVE ENABLE |

### PST DVE Enable

A 'PST DVE Enable' button enables or disables DVE buttons on the preset button row.

To configure a 'PST DVE Enable' button:

- 1 Click a button proxy.
- 2 Choose 'PST DVE Enable' in the button type list.
- 3 Optionally, change the button caption in the 'Mnemonic' field.

This is an example:

| Button | Type           | Mnemonic       |
|--------|----------------|----------------|
| 1      | PST DVE Enable | PST DVE ENABLE |

### Kaleido-X Layout

The 'Kaleido-X layout' button triggers a change to a Kaleido-X layout.

Kaleido-X integration is enabled or disabled in the [Advanced](#) configuration page. When it is enabled, a Kaleido-X button can be used to trigger a *re-layout* of the Kaleido-X multi-viewer. The two fields 'Kaleido-X Room' and 'Kaleido-X layout' are drop-down lists (unless you are working off-line) in which you may select a "room" and a layout for that room.

To configure a 'Kaleido-X Layout' button:

- 1 Click a button proxy.
- 2 Choose 'Kaleido-X Layout' in the button type list.
- 3 Choose a "room" and then choose a layout for the room.
- 4 Optionally, change the button caption in the 'Mnemonic' field.

This is an example:

| Button | Type            | Mnemonic    | KaleidoX Room            | KaleidoX Layout   |
|--------|-----------------|-------------|--------------------------|---|
| 13     | KaleidoX Layout | Kx Layout 1 | ROOMX16                  | Layout 01.kg2   |
|        |                 |             | [Clear Entry]<br>ROOMX16 | [Clear Entry]<br>Layout 04.kg2<br>Layout 02.kg2<br>Layout 01.kg2<br>Layout 12.kg2<br>Layout 09.kg2<br>Layout 06.kg2<br>Layout 18.kg2<br>Layout 10.kg2 |

### Take Functions

There are 2 take button *types* that can be present on a panel:

- Take Primary
- Take Secondary

Each of these requires what is taken to program output to be armed beforehand. Each of these buttons takes a subset of what is armed to program output. An example of a primary function is the A/B mixer. An example of a secondary function is a DSK.

For more information, refer to the *Imagestore 750 User's Guide*.

#### Take Primary

A 'Take Primary' button transitions the *primary* subset of the panel's armed functions to program output.

To configure a 'Take Primary' button:

- 1 Click a button proxy.
- 2 Choose 'Take Primary' in the button type list (under 'Utilities').
- 3 Optionally, change the button caption in the 'Mnemonic' field.

This is an example:

| Button | Type         | Mnemonic |
|--------|--------------|----------|
| 1      | Take Primary | TAKE PRI |

## Take Secondary

A 'Take Secondary' button transitions the *secondary* subset of the panel's armed functions to program output.

To configure a 'Take Secondary' button:

- 1 Click a button proxy.
- 2 Choose 'Take Secondary' in the button type list (under 'Utilities').
- 3 Optionally, change the button caption in the 'Mnemonic' field.

This is an example:

| Button | Type           | Mnemonic |
|--------|----------------|----------|
| 1      | Take Secondary | TAKE SEC |

## Audio Functions

### Audio Lock

An 'Audio Lock' button is a toggle that enables or disables the audio level knobs on the iMC-Panel-200 and iMC-Panel-300. (This feature is designed to prevent accidental changes to the audio levels.)

To configure an 'Audio Lock' button:

- 1 Click a button proxy.
- 2 Choose 'Audio Lock' in the button type list.
- 3 Optionally, change the button caption in the 'Mnemonic' field.

This is an example:

| Button | Type       | Mnemonic   |
|--------|------------|------------|
| 4      | Audio Lock | Audio Lock |

## Transition Type Functions

There are 8 'Transition Type' button functions:

|                        |                       |                 |
|------------------------|-----------------------|-----------------|
| Cut                    | V-Fade (or fade-fade) | V-fade preset 1 |
| Fade-Cut               | Cut-Fade              | V-fade preset 2 |
| X-Fade (or cross fade) | U-fade                |                 |

Transition type buttons are mutually exclusive.

To configure a 'Transition Type' button:

- 1 Click a button proxy.
- 2 Choose one of the 5 transition types in the button type list.  
You cannot change the 'Mnemonic' field because a transition button displays graphics, not text.

This is an example:

| Button | Type     | Mnemonic |
|--------|----------|----------|
| 9      | Cut Fade | Cut Fade |

## Button Functions (for Imagestore 750s)

### Definable Button Functions

---

The parameters of the transition types are defined in the Imagestore 750's configuration. For example, a V-fade can be asymmetric and have a dwell period in the middle:

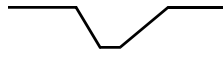

The characteristics of the transition types are defined in the Imagestore 750 configuration.

- ▲ When a transition involves a fade, the fade either goes to black/silence or fades up from black/silence.

## Transition Rate Functions

There are 4 'Transition Rate' button types:

- Slow
- Fast
- Medium
- Automation rate

Transition rate buttons are mutually exclusive. (A button that selects the automation rate selects the rate that was set by the automation system.)

To configure a 'Transition Rate' button:

- 1 Click a button proxy.
- 2 Choose one of the 4 transition rates in the button type list.
- 3 Optionally, change the button caption in the 'Mnemonic' field.

This is an example:

| Button | Type   | Mnemonic |
|--------|--------|----------|
| 9      | Medium | Medium   |

## Automation Assist

There are 4 automation button functions that affect the operation of the automation system's play list:

- 'Cue Next'
- 'Skip Next'
- 'Hold Next'
- 'Take Next'

To configure an automation button:

- 1 Click a button proxy.
- 2 Choose one of the 4 automation buttons in the button type list.
- 3 Optionally, change the button caption in the 'Mnemonic' field.

This is an example:

| Button | Type     | Mnemonic |
|--------|----------|----------|
| 9      | Cue Next | CUE NEXT |

# A

## References

### GPIs

#### Panel GPI

Hardware control panels have 2 GPI inputs and 2 GPI outputs on the GPI/Alarms connector at the rear of the panel. (The GUI, of course, does not.)

GPI inputs are optically isolated, level-sensitive TTL. GPI outputs are SPDT relays, with 3 terminals (COM, NC, and NO) present on the connector.

Power applied to the inputs can be from 5 to 24 VDC, and less than 30 mA. Typically, 5V at 1 mA. Loads for the outputs can be larger:

- Max current: 1 A
- Max voltage: 125 VAC, 110 VDC.
- Max capacity: 62.5 VA, 33 W.
- Rated loads: 1 A at 30 VDC; 0.3 A at 110 VDC; 0.5 A at 125 VAC.

This is a pinout diagram of the GPI/Alarm connector. The pinout is the same for all hardware control panels:

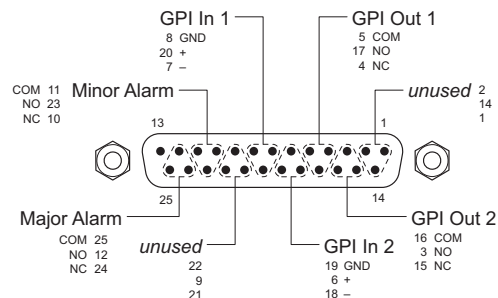

#### MCPM GPI Inputs

The MCPM has two GPI inputs. The MCPM configuration software lets you select a GPI input and specify one of 5 behaviors for the input:

- Toggle control of the emergency bypass relay.
- Level control of the emergency bypass relay.
- Set the EBR to “bypass.”
- Set the EBR to “normal.”
- Disabled. The MCPM ignores the GPI input.

These two inputs relate to the two GPI-MCPM In button functions.

## MCPM GPI Outputs

The MCPM's two GPI outputs are SPDT relays. Connections to the relay terminals are present on the MCPM's aux connector. The MCPM can be configured so that when certain conditions are met, the MCPM activates the output relay — triggering a device that you have connected to the outputs.

(Activation means that the NO-COM circuit closes and the NC-COM circuit opens.)

There are 7 ways an MCPM's GPI output can be activated:

- 1 Disabled. (It does not activate.)
- 2 Controlled from a control panel button press.  
This option relates to the two GPI-MCPM (out) button functions.
- 3 A selected video effect on the program or preset bus.
- 4 For the duration of any transition.
- 5 A selected main source is on the program or preset bus.
- 6 A selected over source is on the program or preset bus.
- 7 The Dolby decoder is in use by any main source on the preset or program bus.

## Imagestore 750 GPI Inputs and Outputs

The GPIO connector is an HD 44-pin connector:

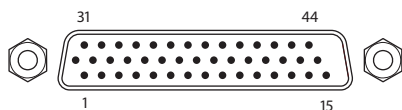

This is its pinout:

| Pin | Signal        | Pin | Signal                 | Pin | Signal        |
|-----|---------------|-----|------------------------|-----|---------------|
| 1   | LTC-          | 16  | RS485/1+               | 31  | LTC+          |
| 2   | LTC_GND       | 17  | RS485/1-               | 32  | GP_GND        |
| 3   | TOTAL_DC_FAIL | 18  | RS485/2+               | 33  | GPIO_16       |
| 4   | GPIO_15       | 19  | RS485/2-               | 34  | GPIO_14       |
| 5   | GPIO_13       | 20  | RS485/3+               | 35  | GPIO_12       |
| 6   | GPIO_11       | 21  | RS485/3-               | 36  | GPIO_10       |
| 7   | GP_+5V        | 22  | RS485/4+               | 37  | TOTAL_DC_FAIL |
| 8   | GP_+12V       | 23  | RS485/4-               | 38  | GPIO_9        |
| 9   | GPIO_8        | 24  | GND                    | 39  | GPIO_7        |
| 10  | GPIO_6        | 25  | GND                    | 40  | GPIO_5        |
| 11  | GPIO_4        | 26  | GND                    | 41  | GPIO_3        |
| 12  | GPIO_2        | 27  | RS232A_TX <sup>a</sup> | 42  | GPIO_1        |
| 13  | GP_GND        | 28  | RS232A_CTS             | 43  | RS232A_RX     |
| 14  | RS232B_TX     | 29  | RS232A_RTS             | 44  | RS232B_RX     |
| 15  | RS232B_RTS    | 30  | RS232B_CTS             |     |               |

a. The RS-232 pins are reserved for future development.



There is a GPIO adapter for this connector. The part number is IS-44-TBA. It is a small circuit board (assembly) that provides Phoenix screw connectors for the inputs and outputs.

There are 16 GPIO pins. Any of these can be an input or an output. There are two GPIO grounds and a +5V and +12V input for GPIO.

Each GPIO terminal can be configured in one of 4 ways:

- GPI Input On — a positive voltage level triggers the GPI input, relative to the GPI ground pin(s).
- GPI Input Off — a (nominally) zero voltage level triggers the GPI input, relative to the GPI ground pin(s).
- GPI Output On — a zero voltage level, relative to the GPI ground pin(s), drives an output circuit.
- GPI Output Off — a positive voltage level, relative to the GPI ground pin(s), drives an output circuit.

GPI inputs can be configured to execute “macros.” (A macro is a sequence of commands, up to 2048 bytes, about 200 commands, such as ‘DSK 1 Fade Up’. A macro can also include GPI output commands.)

A GPI output can be associated with one (of several) internal conditions, such as ‘EAS Running’. The outputs can be configured to turn on or off when its associated condition arises.

## Imagestore 750 AES Connector

The AES connector is a SCSI VHDCI-68 connector with 0.8 mm pin spacing:

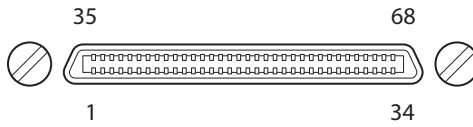

This is its pinout:

| Pin | Signal        | Pin | Signal        | Pin | Signal         | Pin | Signal         |
|-----|---------------|-----|---------------|-----|----------------|-----|----------------|
| 1   | AES_IN_1 (+)  | 35  | AES_IN_1 (-)  | 18  | AES_OUT_1 (+)  | 52  | AES_OUT_1 (-)  |
| 2   | AES_IN_2 (+)  | 36  | AES_IN_2 (-)  | 19  | AES_OUT_2 (+)  | 53  | AES_OUT_2 (-)  |
| 3   | AES_IN_3 (+)  | 37  | AES_IN_3 (-)  | 20  | AES_OUT_3 (+)  | 54  | AES_OUT_3 (-)  |
| 4   | AES_IN_4 (+)  | 38  | AES_IN_4 (-)  | 21  | AES_OUT_4 (+)  | 55  | AES_OUT_4 (-)  |
| 5   | AES_IN_5 (+)  | 39  | AES_IN_5 (-)  | 22  | AES_OUT_5 (+)  | 56  | AES_OUT_5 (-)  |
| 6   | GND           | 40  | GND           | 23  | AES_OUT_6 (+)  | 57  | AES_OUT_6 (-)  |
| 7   | AES_IN_6 (+)  | 41  | AES_IN_6 (-)  | 24  | AES_OUT_7 (+)  | 58  | AES_OUT_7 (-)  |
| 8   | AES_IN_7 (+)  | 42  | AES_IN_7 (-)  | 25  | AES_OUT_8 (+)  | 59  | AES_OUT_8 (-)  |
| 9   | AES_IN_8 (+)  | 43  | AES_IN_8 (-)  | 26  | AES_OUT_9 (+)  | 60  | AES_OUT_9 (-)  |
| 10  | AES_IN_9 (+)  | 44  | AES_IN_9 (-)  | 27  | AES_OUT_10 (+) | 61  | AES_OUT_10 (-) |
| 11  | AES_IN_10 (+) | 45  | AES_IN_10 (-) | 28  | AES_OUT_11 (+) | 62  | AES_OUT_11 (-) |
| 12  | AES_IN_11 (+) | 46  | AES_IN_11 (-) | 29  | AES_OUT_12 (+) | 63  | AES_OUT_12 (-) |
| 13  | AES_IN_12 (+) | 47  | AES_IN_12 (-) | 30  | GND            | 64  | GND            |
| 14  | AES_IN_13 (+) | 48  | AES_IN_13 (-) | 31  | AES_OUT_13 (+) | 65  | AES_OUT_13 (-) |
| 15  | AES_IN_14 (+) | 49  | AES_IN_14 (-) | 32  | AES_OUT_14 (+) | 66  | AES_OUT_14 (-) |
| 16  | AES_IN_15 (+) | 50  | AES_IN_15 (-) | 33  | AES_OUT_15 (+) | 67  | AES_OUT_15 (-) |
| 17  | AES_IN_16 (+) | 51  | AES_IN_16 (-) | 34  | AES_OUT_16 (+) | 68  | AES_OUT_16 (-) |

The inputs and outputs are balanced differential pairs.

Breakout boxes are available for 110Ω and 75Ω BNCs. The part numbers are ABT-32-32-D110 and ABT-32-32-D75 respectively. Connect the breakout box to the AES port using a SCSI VHDCI-68 male/male cable. The cable must have connectors with 0.8 mm pin spacing.

# G

## Glossary

|                             |   |
|-----------------------------|---|
| <b>Aux/Preview GUI</b>      | A variant of the CECP GUI having no preset or program buttons, no audio meter/monitor section, no transition button, fewer button functions, and fewer menus. The Aux/Preview GUI is a legacy GUI.  |
| <b>Breakaway</b>            | A transition that takes audio from one source and video from another source.  |
| <b>Control panel</b>        | A console (hardware or software) at which an operator initiates and controls program transitions.   |
| <b>CECP</b>                 | Compact Enhanced Control Panel. The NV5100MC-CECP hardware control panel.   |
| <b>CECP GUI</b>             | Software Control Panel. The NV5100MC-GUI control panel.   |
| <b>CFCP</b>                 | Compact Full-Function Control Panel. A legacy hardware control panel (NV5128-MC-CFCP).  |
| <b>Flip-flop, flip-only</b> | In “flip-flop” mode, the contents of the preset and program buses swap. In flip-only mode, the buses are identical after the transition.  |
| <b>FECP</b>                 | Full-Sized Enhanced Control Panel. The NV5100MC-FECP hardware control panel.  |
| <b>FFCP</b>                 | Full-Function Control Panel. A legacy hardware control panel (NV5128-MC-FFCP).  |
| <b>GPI</b>                  | General-Purpose Interface. An MCPM has 2 GPI inputs and 2 GPI outputs. A hardware control panel has 2 GPI inputs and 2 GPI outputs. See <a href="#">GPIs</a> on page 193 for more detail. A software control panel has no GPIs of its own, but it can control and provide status for MCPM GPIs. |
| <b>GUI</b>                  | Graphical User Interface. The NV5128-MC-GUI is the oldest. The <i>original</i> NV5100MC-GUI software is newer. The <i>modified</i> NV5100MC-GUI software is the newest and can control Imagestore 750s. (The Aux/Preview GUI is a configuration option of the <i>original</i> NV5100MC-GUI.)    |
| <b>Imagestore 750</b>       | The Imagestore 750 is a 1RU transition processor, also called a “channel branding processor.” It has several purchase options, including a master control option that allows it to function in the context of the combined Imagestore 750/NV5100MC master control system.                       |
| <b>iMC-Panel-100</b>        | 3RU rack-mounted control panel with separate rack-mountable touchscreen display. This panel, physically derived from the SCP, but architecturally similar to the iMC-Panel-200, can control Imagestore 750s.  |
| <b>iMC-Panel-200</b>        | Compact control panel. This panel, based on the CECP, can control Imagestore 750s.  |
| <b>iMC-Panel-300</b>        | Full-Sized control panel. This panel, based on the FECP, can control Imagestore 750s.   |
| <b>iMC-Panel-GUI</b>        | Software Control Panel. This panel, based on the CECP GUI, can control Imagestore 750s.   |
| <b>Intuition XG</b>         | Intuition XG is a combination of a Intuition XG graphics processor and Xmedia software.   |
| <b>IP address</b>           | A 32-bit number that identifies a device on a network. The address is usually expressed as four 8-bit values, in decimal notation, joined by periods (e.g., 192.168.7.20). (Although IP means “internet protocol,” here we just mean network address.)  |

## Glossary

---

|                      |   |
|----------------------|---|
| <b>MCE</b>           | <i>Master Control Engine.</i> A “next generation” transition processor or “channel” located in the master control frame. Master control supports both SD and HD MCEs.         |
| <b>MCPM</b>          | <i>Master Control Processing Module.</i> A transition processor or “channel” located in the frame. Master control supports both SD and HD MCPMs.                              |
| <b>SCP</b>           | Simple control panel. The NV5128-MC-SCP hardware control panel.   |
| <b>Transition</b>    | The process by which the MCPM moves the content of the preset bus (source and layers) to the program bus. Transitions are governed by transition type and transition rate.    |
| <b>Vertigo XG</b>    | A single- or dual-channel HD/SD graphics processor.   |
| <b>XG Dash-board</b> | Configuration tool for Vertigo XG.  |
| <b>XMedia</b>        | A collection of configuration and creative software used with Intuition XG.   |
| <b>Xbuilder</b>      | “Template population” and “promo timeline control” software for Intuition XG.   |
| <b>XPlay</b>         | A “media event sequencer” used to configure the Vertigo XG and to manage clips. Xplay must be running on the Vertigo XG processor for correct operation under master control. |
| <b>Xstudio</b>       | “Template creation” software for Intuition XG.  |

# Index

## A

- A, bank ..... 144
- A, monitor ..... 28, 35, 52, 146
- Abbreviations ..... 2
- Abort (button) ..... 153–154
- About MCS panel configuration editor (command) ... 97
- Acrobat usage ..... 2
  - bookmarks ..... 2
  - hyperlinks ..... 2
  - navigating and searching ..... 2
- Active configuration files ..... 101
- Add panel (command) ..... 99
- Address, IP ..... 30, 38, 45, 55, 60, 68, 71, 81, 85, 96,  
..... 100–102, 106, 113, 160
- Adjusting effect settings . 33, 47, 58, 63, 66, 70, 74, 76–77
- Advanced settings (page) ..... 114, 116, 166–167
- AES output ..... 10
- Africa, contact ..... 211
- agreement, license ..... iii
- Alarm
  - connector ..... 81, 193
  - connectors ..... 30–32, 37–38, 44–45, 54–55, 57, 60,  
..... 66, 68–69, 71–72
- All events (logging level) ..... 112, 165
- Americas, contact ..... 211
- Analog audio output ..... 10, 14
- Applications
  - MasterConfig ..... 3
  - MasterDiag ..... 3
  - MasterLogo ..... 3
  - MCS panel configuration editor ..... 4, 21, 23, 83
- Arrows, up/down ..... 72, 74
- Asia, contact ..... 211
- Attach to NV9000 (option) ..... 113, 137
- Audio
  - aux inputs ..... 67
  - backup ..... 147
  - channels ..... 12, 27, 34, 48, 52
  - crosspoint matrix ..... 148
  - level ..... 33, 35, 47, 58–59, 63, 66–67, 70, 74, 76
  - level buttons ..... 150
  - level control ..... 28–30, 34, 42, 44, 52, 54, 58, 146
  - levels ..... 79–80, 150
  - macro buttons ..... 148
  - metering ..... 12, 14–15, 59, 63, 67, 70, 74
  - metering connectors ..... 31, 38, 55, 61
  - meters ..... 12, 80
  - monitoring ..... 35, 59, 63, 65, 67, 70, 74
  - monitors ..... 12, 28, 35, 52, 80, 146
  - off-air inputs ..... 67
  - output, analog ..... 14
  - over buttons ..... 26, 36, 41–42, 48, 51, 59, 63, 82, 120
  - over ratio ..... 59, 67, 71, 79
  - overs ..... 12–13, 33, 37, 57, 59, 65–67, 70–71, 74,  
..... 78–79, 121, 172
  - processing section, internal ..... 63, 67, 74
  - section, GUI ..... 63, 74, 77
  - settings ..... 63, 74, 77
  - sources ..... 67
- Audio follows video (paradigm) ..... 12
- Audio levels (section) ..... 28, 52
- Audio lock (button) ..... 140–141, 191
- Audio macros ..... 129, 148, 177
- Audio monitoring layout (page) ..... 127, 129, 174
- Audio only (button) ..... 146
- Auto off (button) ..... 60, 64, 71, 75, 78
- Automatic gang mode ..... 82, 107, 136–137
- Automatic navigation to menus ..... 117
- Automation ..... 8, 12–13, 140–141, 151, 186
- Automation off
  - color ..... 119, 171
- Automation off (button) ..... 119, 140, 171, 186
- Automation rate (button) ..... 192
- Aux
  - bus ..... 27, 37, 49–50, 52, 59, 64, 77, 121, 126, 133, 173
  - buttons ..... 9, 85, 104, 127, 158
  - inputs ..... 67
  - outputs ..... 27, 37, 49, 52, 127
- Aux delegate (buttons) . 27, 37, 49, 52, 59, 64, 77, 125, 133
- Aux delegates (page) ..... 125
- Aux row (page) ..... 175
- Aux/preview GUI ..... 76
- Aux/user buttons ..... 26, 36, 49

## B

- B, bank ..... 144
- B, monitor ..... 28, 35, 52, 146
- Backup audio ..... 147
- Bank select (button) ..... 144
- Bank selection ..... 65, 67, 79, 144
- Banks A and B ..... 121–122, 144, 173
- Black/silence ..... 13, 60, 64, 66, 70–71, 75, 78
- BNC connectors ..... 31, 38, 55, 61

- 
- Bold-face or capital letters, usage ..... 2
  - Bookmarks, Acrobat ..... 2
  - Bottom row layout (page) ..... 110, 134, 164
  - Branding engines ..... 10
  - Breakaway ..... 66–67, 71, 74, 79, 146, 197
    - buttons ..... 146
  - Brightness, panel LCD ..... 118, 168
  - Bus
    - aux ... 27, 37, 49–50, 52, 59, 64, 77, 121, 126, 133, 173
    - monitor ..... 80
    - preset ..... 12, 36–37, 59, 65, 67, 71, 74, 79
    - preview ..... 26–27, 36–37, 49–50, 52, 59, 63–64,
      - ..... 77, 120–121, 126
    - program ..... 26, 36–37, 42, 49, 59, 65, 67, 71, 74,
      - ..... 78–79, 194
  - Button
    - abort ..... 153–154
    - audio lock ..... 140–141, 191
    - audio only ..... 146
    - auto off ..... 60, 64, 71, 75, 78
    - automation off ..... 119, 140, 171, 186
    - automation rate ..... 192
    - bank select ..... 144
    - channel control ..... 136
    - channel select ..... 135, 182
    - channel status ..... 136
    - color ..... 29, 31, 33, 43, 45, 47, 56–57, 61–62, 65–66,
      - ..... 69–70, 72–73, 75–76
    - cue ..... 153
    - cue next ..... 192
    - cut ..... 145, 191
    - cut-fade ..... 145, 191
    - dim A ..... 146
    - dim B ..... 146
    - emergency bypass control ..... 145
    - emergency bypass status ..... 145
    - fade to black ... 60, 64, 71, 75, 78, 140–141, 186, 188
    - fade to silence ..... 186, 189
    - fade-cut ..... 145, 191
    - fast ..... 146, 192
    - fast forward ..... 153
    - fire macro ..... 186, 188
    - flip-flop ..... 144
    - FTB ..... 141–142
    - gang channels ..... 135–136, 182, 184
    - GPI panel in ..... 184
    - group select ..... 140, 143, 186
    - hold next ..... 192
    - install ..... 96
    - Int XG ..... 12
    - Kaleido-X layout ..... 117, 140, 143, 190
    - legends 29, 33, 43, 47, 57, 62, 65–67, 70–71, 73–74, 76
    - live levels ..... 134, 148
    - load software ..... 95
    - macro arm ..... 186, 188
    - mapping ..... 79
    - mark ..... 153–154
    - MCPM GPI input ..... 138
    - MCPM GPI output ..... 138
    - medium ..... 146, 192
    - menu ..... 186–187
    - meters ..... 149
    - monitor A ..... 149
    - monitor B ..... 149
    - no channels ..... 135, 182–183
    - panel GPI input ..... 138
    - panel GPI input/output ..... 138, 184
    - panel GPI output ..... 138, 184
    - panel lock ..... 28, 37, 50, 53, 60, 64, 68, 71, 75, 78,
      - ..... 140, 186
    - pause ..... 153–154
    - PB cut ..... 145
    - PB cut-fade ..... 145
    - PB fade-cut ..... 145
    - PB v-fade ..... 145
    - PGM DVE enable ..... 186, 189
    - play ..... 153
    - pre-roll ..... 153–154
    - preset Dolby-E control ..... 147
    - preset Dolby-E status ..... 147
    - preset main audio level ..... 150
    - preset main button map ..... 151
    - preset main router ..... 151
    - preset over audio level ..... 150
    - preset over audio ratio ..... 150
    - preset over button map ..... 151
    - preview Int XG ..... 12
    - program Dolby-E control ..... 147
    - program Dolby-E status ..... 147
    - program main audio level ..... 150
    - PST DVE enable ..... 186, 189
    - ready ..... 153–154
    - rewind ..... 153
    - salvo ..... 137, 183
    - skip next ..... 192
    - slow ..... 146, 192
    - stop ..... 153
    - system status ..... 140, 142–143
    - take next ..... 192
    - Take primary ..... 190
    - Take secondary ..... 191
    - text ..... 29, 33, 43, 45, 57, 61, 65–66, 70, 72, 75, 142
    - transition ... 28, 33, 37, 42, 48, 50, 53, 58, 60, 63–64,
      - ..... 66, 70, 74, 77–78, 80
    - transition hold ..... 140–141
    - update config ..... 86
    - v-fade ..... 145, 191
    - video only ..... 146
    - XG keyer control ..... 12, 133, 154
    - XG layer ..... 12, 121–122
  - Button assignments (page) ..... 120, 172
  - Button color ..... 118–119, 171

Button functions ..... 186, 190  
 Button proxy ..... 135–141, 143–155, 182–192  
 Button table ..... 121, 173  
 Buttons  
   audio level ..... 150  
   audio macro ..... 148  
   audio over ..... 26, 36, 41–42, 48, 51, 59, 63, 82, 120  
   aux ..... 9, 85, 104, 127, 158  
   aux delegate ..... 27, 37, 49, 52, 59, 64, 77, 125, 133  
   aux/user ..... 26, 36, 49  
   breakaway ..... 146  
   channel ..... 109  
   color ..... 28, 53, 57, 80, 134, 136, 142, 182  
   control panel ..... 2  
   definable ..... 110, 134, 163, 182  
   Dolby E control ..... 147  
   Dolby E status ..... 147  
   function ..... 63, 74, 77  
   functions ..... 21, 25, 40, 51, 78–79, 110–111, 124,  
     ..... 134, 164, 175–176, 182  
   gang channels ..... 107  
   GPI input ..... 138, 185  
   GPI input/output ..... 139, 185  
   GPI output ..... 138, 184  
   layer ..... 26, 36–37, 41–42, 48–49, 51, 59, 63, 71, 74,  
     ..... 78–79, 120  
   LCD ..... 31, 56, 65–66, 69–70, 78  
   legends ..... 27, 34, 48, 52, 134, 182  
   list ..... 124  
   machine control ..... 153  
   main source ..... 26, 36, 41–42, 48–49, 51, 59, 63,  
     ..... 82, 120, 172  
   menu ..... 79, 152–154  
   modifiable ..... 82  
   mutually exclusive ..... 29, 33, 43, 47, 53, 58, 63, 66,  
     ..... 70, 73, 76, 80  
   navigation ..... 80, 124, 152–153  
   over ratio ..... 150  
   panel ..... 67  
   physical ..... 28, 42, 53, 80  
   preset ..... 120  
   preview ..... 9, 49, 89, 147  
   preview/user ..... 26, 36, 49, 85  
   program ..... 120  
   programmable ..... 34, 48, 58, 63, 67, 70, 74, 77  
   status ..... 29, 33, 43, 53, 57, 62, 79–80  
   system ..... 37, 50, 60, 64, 68, 71, 75, 78  
   toggle ..... 29, 33, 43, 53, 70, 80, 138, 140–141,  
     ..... 144–147, 184, 186, 188–189, 191  
   transition ..... 67  
   transition rate ..... 146, 192  
   transition type ..... 145, 191  
   video effect ..... 26, 36, 41–42, 51, 59, 63, 120  
   virtual ..... 67  
   virtual main source ..... 79, 144

  voice-over ..... 26, 36, 49, 172  
 XG keyer control ..... 154  
 Bypass  
   emergency ..... 12, 14–15, 144  
   mode ..... 11  
   relay, emergency ..... 144, 193

## C

Categories, router ..... 113  
 Category IDs ..... 113  
 Cautions ..... v  
 CD, master control software and documentation .. 3, 123  
 CE ..... ii  
 CECP (compact enhanced control panel) ..... 2, 9, 51, 61  
   dimensions ..... 50  
   sections ..... 51  
 CECP GUI ..... 75, 95, 197  
 CECP M1 ..... 2, 106, 133–134, 148  
 CFCP (compact full-function control panel) 2, 9, 64–66, 68  
   dimensions ..... 31, 56  
 Change (command) ..... 100  
 Change file (command) ..... 100  
 change history ..... ii  
 Changing channels ..... 8, 137, 183  
 Channel  
   buttons ..... 109  
   default ..... 81, 106, 160  
   selection ..... 27, 29–30, 33–34, 44, 48, 52, 54, 58, 63,  
     ..... 67, 74, 77, 79, 81, 135, 182  
 Channel control (button) ..... 136  
 Channel select (button) ..... 135, 182  
 Channel selection list (page) ..... 106–107, 160  
 Channel status (button) ..... 136  
 Channel thumbnails ..... 108  
 Channels ..... 7–8, 21, 81, 135, 182  
   audio ..... 12, 27, 34, 48, 52  
   changing ..... 8, 137, 183  
   ganged ..... 82, 135, 137  
 Channels (command) ..... 93  
 Chapter structure ..... 1  
 Chapters  
   1, Preface ..... 1  
   2, Introduction ..... 7  
   3, Control Panels ..... 23  
   4, Editor Basics ..... 83  
   5, Operation (for MCEs and MCPMs) ..... 103  
   6, Button Functions (for MCEs and MCPMs) ..... 131  
   7, Operation (for Imagestore 750) ..... 157  
   8, Button Functions (for Imagestore 750) ..... 181  
 China, contact ..... 211  
 Clean feed output ..... 14–15  
 Clear preset after transition (mode) ..... 12  
 Closed is selected (option) ..... 139, 185

- 
- Color, button ..... 29, 31, 33, 43, 45, 47, 56–57, 61–62, 65–66, 69–70, 72–73, 75–76
  - Color, buttons ..... 28, 53, 57, 80, 118–119, 134, 136, 142, 171, 182
  - Commands
    - about MCS panel configuration editor ..... 97
    - add panel ..... 99
    - change ..... 100
    - change file ..... 100
    - channels ..... 93
    - delete ..... 99
    - exit ..... 91
    - get panel software versions ..... 94
    - new ..... 88, 101, 105, 159
    - NV9000 systems ..... 93
    - obtaining technical support ..... 98
    - open ..... 89, 102
    - open file ..... 100, 102
    - panels ..... 92
    - read config from panel ..... 91, 95, 101
    - read log from panel ..... 112, 165
    - rename ..... 99
    - save ..... 89, 101–102
    - save as ..... 89, 101–102
    - search for devices ..... 92
    - set all to defaults ..... 94
    - update panel software ..... 95
    - write config to panel ..... 89, 102
  - Compact enhanced control panel
    - see CECP
    - see CECP M1
  - Compact enhanced control panel (CECP) ..... 2, 9, 50–51
  - Compact full-function control panel
    - see CFCP
  - Configurable button section ..... 27, 34, 41, 48, 52, 110, 146, 163
  - Configuration
    - active files ..... 101
    - files ..... 83, 86–87, 89, 102
    - MCPM ..... 148
    - new files ..... 101
    - pages ..... 103, 157
    - PC ..... 3
    - stored files ..... 102
  - Configuration files ..... 86, 101
  - Configuration guidelines ..... 98
  - Configuration pages ..... 84, 104, 158
  - Configurations
    - hardware control panel ..... 102
    - new ..... 103, 158
    - updating ..... 102
  - Connectors ..... 54
    - audio metering ..... 31, 38, 55, 61
    - BNC ..... 31, 38, 55, 61
    - CFCP ..... 68
    - CP aux ..... 32, 60, 66, 68–69, 71–72
    - DB15 ..... 32, 60, 66, 68–69, 72
    - DB25 ..... 30–32, 37–38, 44–45, 54–55, 57, 60, 66, 68–69, 72
    - Ethernet ..... 30, 32, 37–38, 44–45, 54–55, 57, 60, 66, 68–69, 71
    - FECF ..... 60
    - FFCP ..... 71
    - GPI/alarm ..... 30–32, 37–38, 44–45, 54–55, 57, 60, 66, 68–69, 71–72, 81, 193
    - iMC-Panel-300 ..... 37
    - power ..... 30, 32, 37, 44–45, 54–55, 57, 60, 66, 68–69, 71, 81
    - RJ-45 ..... 30, 32, 37–38, 44–45, 54–55, 57, 60, 66, 68–69, 71
  - contact Miranda ..... 211
  - Control panel
    - buttons ..... 2
    - mounting ..... 9–10
    - reading configuration data ..... 91, 95
    - type ..... 103–105, 158–159
    - writing application ..... 95
    - writing configuration data ..... 89
  - Control panels ..... 3, 8, 83, 197
    - and channels ..... 8
  - Controlled from UI, GPI output ..... 194
  - Controller, device (DC21) ..... 3–4, 11
  - Conventions ..... 2
  - corporate office, contact ..... 211
  - CP aux connectors ..... 32, 60, 66, 68–69, 71–72
  - Creating a new configuration file ..... 101
  - Cross fade ..... 13, 64, 67, 71, 75
  - Cue (button) ..... 153
  - Cue next (button) ..... 192
  - Cursor, hiding ..... 119
  - customer support ..... 211
  - Customer-definable buttons ..... 34, 48, 58, 63, 67, 70, 74, 77
  - Cut ..... 13, 64, 67, 71, 75
  - Cut (button) ..... 145, 191
  - Cut, hot ..... 13
  - Cut-fade ..... 13, 64, 67, 71, 75
  - Cut-fade (button) ..... 145, 191
- ## D
- Dashboard ..... 3, 12, 198
  - DB15 connectors ..... 32, 60, 66, 68–69, 72
  - DB25 connectors ..... 30–31, 37–38, 44–45, 54–55, 60, 66, 68, 72
  - DC21 device controller ..... 3–4, 11
  - Debug (logging level) ..... 112, 165
  - Declaration of Conformance ..... ii
  - Decoders, Dolby E ..... 14, 147–148, 194
  - Default channel ..... 81, 106–107, 136, 160
  - Default configuration (SCP) ..... 123–124
  - Default IP address, MCPM ..... 108, 162



Default IP address, panel ..... 100  
 Default MCPM ..... 107  
 Definable buttons ..... 110, 134, 163, 182  
 Delete (command) ..... 99  
 Deleting menus ..... 123  
 Device controller (DC21) ..... 3–4, 11  
 Dim A (button) ..... 146  
 Dim B (button) ..... 146  
 Dim function ..... 63, 67, 74, 146  
 Disabled, GPI output ..... 194  
 DNF Controls ..... 3  
 document  
   notice of use ..... ii  
   part number ..... ii  
   revision ..... ii  
 Documentation  
   abbreviations ..... 2  
   conventions ..... 2  
   symbols ..... 2  
   terms ..... 2  
 Dolby E ..... 12  
   buttons ..... 147  
   control buttons ..... 147  
   decoders ..... 14, 147–148, 194  
   modules (optional) ..... 12  
   status buttons ..... 147  
 Downstream keyer ..... 20, 26, 36, 49, 172  
 DSK ..... 20  
   see downstream keyer  
 DSK selection ..... 30, 34, 44  
 DVE ..... 172  
   digital video effect  
 DVE selection ..... 26, 30, 34, 36, 44, 49, 172

**E**

EBCP (emergency bypass control panel) ..... 11  
 Edit (menu) ..... 92  
 Effects, video ..... 12–13, 26, 28, 33, 36–37, 42, 47, 49, 51,  
   ..... 53, 57, 59, 62, 64–67, 70–71, 73–74, 76,  
   ..... 78–80, 82, 121, 172, 194  
 e-mail address ..... 211  
 Emergency bypass ..... 11–12, 14–15, 144  
   relay ..... 144, 193  
 Emergency bypass control (button) ..... 145  
 Emergency bypass control panel (EBCP) ..... 11  
 Emergency bypass status (button) ..... 145  
 Enable automatic navigation to menus ..... 117  
 Enable global source groups ..... 119  
 Error messages ..... 29–30, 34, 44, 54, 58  
 Errors (logging level) ..... 112, 165  
 Ethernet ..... 8  
   connectors ..... 30, 32, 37–38, 44–45, 54–55, 57, 60,  
   ..... 66, 68–69, 71  
   port ..... 81

Europe, contact ..... 211  
 Examples, symbol for ..... 2  
 Exit (command) ..... 91  
 Extensions, file name ..... 91

**F**

Fade to black (button) ..... 60, 64, 71, 75, 78, 140–141,  
   ..... 186, 188  
 Fade to black/silence (FTB) ..... 13, 60, 64, 66, 70–71,  
   ..... 75, 78, 141–142  
 Fade to silence (button) ..... 186, 189  
 Fade/cut ..... 64, 68, 71, 75  
 Fade-cut ..... 13  
 Fade-cut (button) ..... 145, 191  
 Fade-fade ..... 13  
 Fan ..... 81  
 Fast (button) ..... 146, 192  
 Fast forward (button) ..... 153  
 Fast transition ..... 13, 68, 71, 75  
 fax number ..... 211  
 FCC statement ..... ii  
 FECP ..... 59, 127  
 FECP (full-size enhanced control panel) ..... 2, 10, 58, 60  
 FFCP ..... 2, 9, 95  
 FFCP (full-function control panel) ..... 33, 57, 69–72  
   connectors ..... 71  
 File (menu) ..... 87–88  
 File name extensions ..... 91  
 Files, configuration ..... 83, 86–87, 89, 102  
 Find, Acrobat ..... 2  
 Fire macro (button) ..... 186, 188  
 First Page, Acrobat ..... 2  
 Flip-flop (button) ..... 144  
 Flip-flop mode ..... 82, 117, 144, 197  
 Flip-only mode ..... 82, 117, 144, 197  
 Follower (ganged) channels ..... 136, 184  
 Forced backup audio (FBA) ..... 147  
 Frame  
   NV5100MC ..... 3, 7  
 France, contact ..... 211  
 FTB (button) ..... 141–142  
 FTB (fade to black/silence) ... 13, 60, 64, 66, 70–71, 75, 78  
   matte ..... 13, 141  
   transitions ..... 13  
 Full-function control panel ..... 2, 9  
   see FFCP  
 Full-size enhanced control panel (FECP) ..... 2, 10  
 Full-sized enhanced control panel  
   see FECP  
 Function buttons ..... 25, 40, 51, 63, 74, 77–79, 124  
 Functions, button ..... 21, 110–111, 124, 134, 164,  
   ..... 175–176, 182  
 Functions, system ..... 124

## G

Gang channels (button) ..... 107, 135–136, 182, 184  
 Ganged channels ..... 82, 135, 137  
 General settings (page) ..... 105, 159  
 General-purpose interface  
   see GPI  
 Get panel software versions (command) ..... 94  
 Global source groups ..... 119  
 Go to Next View, Acrobat ..... 2  
 Go to Previous View, Acrobat ..... 2  
 GPI ..... 12, 27, 34, 48, 52, 137, 184, 193, 197  
   closed is selected (option) ..... 139, 185  
   events ..... 79  
   input ..... 138, 185, 193  
   input buttons ..... 138, 185  
   input/output ..... 139, 185  
   input/output buttons ..... 139, 185  
   inputs ..... 31, 38, 45, 55, 60, 68, 72  
   MCPM ..... 193–194  
   open is selected (option) ..... 139, 185  
   output ..... 138, 184, 194  
   output buttons ..... 138, 184  
   output, and main source ..... 194  
   output, and transition status ..... 194  
   output, and video effect type ..... 194  
   output, controlled from UI ..... 194  
   output, disabled ..... 194  
   outputs ..... 31, 38, 45, 55, 60, 68, 72  
   panel ..... 193  
 GPI panel in (button) ..... 184  
 GPI/alarm connectors ..... 30–32, 37–38, 44–45, 54–55, 57,  
   ..... 60, 66, 68–69, 71–72, 81, 193  
 GPIO ..... 14–15, 67, 137, 184  
 Graphical user interface  
   see GUI ..... 9  
 Graphical user interface (GUI) ..... 8–9  
 Ground lug ..... 68, 72  
 Group select (button) ..... 140, 143, 186  
 Groups, source ..... 119  
 GUI ..... 197  
 GUI (software control panel) ..... 8–9, 61–62, 64, 72–73,  
   ..... 75, 77, 87, 102  
   logs ..... 112, 165  
   window ..... 45, 61, 72, 75  
 GUI, aux/preview ..... 76  
 GUI, CECP ..... 75, 95  
 GUI, modified  
 GUI, new  
 GUI, old  
 GUI, PC ..... 9  
 Guidelines, configuration ..... 98

## H

hardware symbols ..... iv  
 hazardous substance ..... iii  
 HD video ..... 10  
 Help (menu) ..... 87, 97  
 Hide mouse cursor (option) ..... 119  
 High-tally ..... 28–29, 33, 43, 45, 47, 53, 57, 61–62, 66, 70,  
   ..... 72–73, 75–76, 79–80  
 Hold next (button) ..... 192  
 Hold, transition ..... 141  
 Hot cuts ..... 13  
 hours of operation ..... 211  
 How to  
   assign functions to configurable buttons ..... 131, 181  
   create a new configuration file ..... 101  
   modify a stored configuration file ..... 102  
   modify an active configuration file ..... 101  
   update a panel configuration ..... 102  
   use the configuration editor ..... 83  
   use the configuration pages ..... 103, 157  
   use this guide ..... 2  
 Hyperlinks, Acrobat ..... 2

I

IDs, salvo ..... 109, 137, 163  
 Iimagestore 750 ..... 20, 197  
 iMC-Panel-100  
   USB ports ..... 44  
   VGA port ..... 44  
 iMC-Panel-100 (rack-mount control panel) ..... 2, 108  
 iMC-Panel-100 monitor ..... 43  
 iMC-Panel-100 rack-mount control panel) ..... 197  
 iMC-Panel-200 (compact control panel) ..... 2, 9, 26, 45, 48,  
   ..... 94, 133–134, 148, 191, 197  
   dimensions ..... 25, 39  
   sections ..... 25, 40  
 iMC-Panel-300 (full-size control panel) ..... 2, 9, 26, 33–34,  
   ..... 36–37, 127, 134, 148, 174, 197  
 iMC-Panel-GUI (software control panel) ..... 2, 8–9, 46–47, 49  
 Input, GPI ..... 138–139, 185, 193  
 Inputs  
   aux ..... 67  
   GPI ..... 31, 38, 45, 55, 60, 68, 72  
   off-air ..... 67  
 Install (button) ..... 96  
 Int XG (button) ..... 12  
 Intuition XG 3–4, 11, 13, 15–16, 20, 117, 121, 133, 154, 197  
 IP address .. 30, 38, 45, 55, 60, 68, 71, 81, 85, 96, 100–102,  
   ..... 106, 113, 160, 197  
   default MCPM ..... 108, 162  
   GUI ..... 100  
   right-click to change ..... 100

IP subnet mask ..... 30, 38, 45, 55, 60, 68, 71

## J

Joystick .....9, 27, 31, 35, 50, 52, 56, 59, 89

## K

Kaleido-X integration ..... 107, 117, 143  
     and channel selection ..... 117  
 kaleido-X integration ..... 117, 167  
 Kaleido-X layout (button) ..... 117, 140, 143, 190  
 Kaleido-X multi-viewer ..... 21, 107, 117, 143  
 Keyer settings .....27, 33–34, 47–48, 52, 58, 63, 66, 70, 74,  
     ..... 76–77  
 Keyers ..... 10, 12–13, 37, 59, 67, 71, 74, 79  
 Keyers, downstream ..... 20  
 Knob proxies ..... 48  
 Knobs .....25, 27–29, 33, 35, 40–43, 51–52, 54, 58, 78–80  
 Knobs, panel ..31, 33, 48, 56, 58, 63, 65–67, 69–70, 74, 77

## L

Last Page, Acrobat ..... 2  
 Layer buttons 26, 36–37, 41–42, 48–49, 51, 59, 63, 71, 74,  
     78- ..... 79, 120  
 Layer section ..... 42  
 LCD  
     brightness ..... 118, 168  
     buttons ..... 31, 56, 65–66, 69–70, 78  
     touchscreen .....9, 25, 27, 29, 31, 33, 40, 51–52, 54,  
         ..... 56, 58, 65–67, 69–70  
 Legends, button ..... 27, 29, 33–34, 43, 47–48, 52, 57, 62,  
     ..... 65–67, 70–71, 73–74, 76, 134, 182  
 Level, audio ..... 28–30, 33–35, 44, 47, 52, 54, 58–59, 63,  
     .....66–67, 70, 74, 76, 79–80, 146, 150  
 Levels  
     audio ..... 42  
 license ..... iii  
 Linear keyers .....10, 12–13, 37, 59, 67, 71, 74  
 List area, panel ..... 83, 85, 100  
 List buttons ..... 124  
 Lists ..... 79  
 Live levels (button) ..... 134, 148  
 Load software (button) ..... 95  
 Lock, audio ..... 141, 191  
 Lock, panel .....79, 140, 186  
 Log files ..... 112, 165  
 Logging levels ..... 111, 165  
 Logging settings (page) ..... 111, 165  
 Logos ..... 10, 13–14, 37, 59, 67, 71, 74, 79  
 LOS ..... 79

Low-tally .....28–29, 33, 43, 45, 47, 53, 57, 61–62, 66, 70,  
     .....72–73, 75–76, 79–80  
 Lug, ground ..... 68, 72  
 Luminance .....13

## M

Machine control .....3–4, 11, 15–16, 133, 153–154  
 Machine control buttons ..... 153  
 Macro arm (button) .....186, 188  
 Macros, audio ..... 129, 148, 177  
 Main (ganged) channel .....136, 184  
 Main (menu) ..... 123  
 Main source .....33, 37, 47, 57, 59, 62, 65–67, 70–71,  
     ..... 73–74, 76  
 Main source button qty .....121, 173  
 Main source buttons .....26, 36, 41–42, 48–49, 51, 59,  
     .....63, 82, 120, 172  
 Main source buttons, physical ..... 121  
 Main source buttons, virtual ..... 121  
 Main sources ..... 12, 26, 28–30, 33–34, 36, 42–44, 48–49,  
     ..... 51, 53–54, 58–59, 64, 78–80, 150, 194  
 Main window .....84  
 Maintenance, panel ..... 29–30, 34, 44, 54, 58  
 Manual transitions .....13  
 Mapping sources to buttons ..... 79, 151  
 Mark (button) ..... 153–154  
 Mark point ..... 153  
 Mask, subnet ..... 30, 38, 45, 55, 60, 68, 71  
 Master control  
     application pathnames .....87  
     network .....30, 38, 45, 47, 55, 60–61, 68, 71–73, 75  
     processing module ..... 2–3  
     tree .....98  
 Master control engine  
     see MCE  
 Master control in conjunction with NV9000 .....4  
 Master control processing module  
     see MCPM  
 Master control software and documentation CD .. 3, 123  
 Master fade to black ..... 141–142  
 MasterConfig ..... 153  
 MasterConfig (application) .....3  
 MasterDiag (application) .....3  
 MasterGUI.uicfg ..... 102  
 MasterLogo (application) .....3  
 Matte, FTB ..... 13, 141  
 MCE .....10, 198  
     audio expansion module .....15  
     core module .....15  
     digital video effects module .....15  
     preview module .....15  
     summary .....15  
 MCE-AXM .....15  
 MCE-CORE .....15

- 
- MCE-DVE ..... 15
  - MCE-PVW ..... 15
  - MCPM ... 2–3, 10, 12, 26, 36, 48–49, 51, 59, 64, 78–80, 198
    - configuration ..... 148
    - GPI ..... 12, 193–194
    - GPI inputs and outputs ..... 138
    - IP address ..... 81, 106, 160
    - type ..... 10
  - MCPM (master control processing module) ..... 7–8
  - MCPM GPI input (button) ..... 138
  - MCPM GPI output (button) ..... 138
  - MCPM-HD ..... 10, 14
  - MCPM-HD2 ..... 10, 14
  - MCPM-MK-HD ..... 10, 14
  - MCPM-MK-SD ..... 10, 14
  - MCPM-SD ..... 10, 14
  - MCPM-SDHD ..... 10, 14
  - MCS panel configuration editor (application) 4, 21, 23, 97
    - overview ..... 83
  - Medium (button) ..... 146, 192
  - Medium transition ..... 13, 68, 71, 75
  - Menu
    - bar ..... 84, 87
    - edit ..... 92
    - file ..... 87–88
    - help ..... 87, 97
    - knob proxies ..... 48
    - knobs ..... 27, 29, 33, 35, 41, 52, 54, 58
    - main ..... 123
    - panel ..... 123
    - panel ID ..... 71
    - system ..... 29, 33, 43, 54, 58
    - tools ..... 87
  - Menu (button) ..... 186–187
  - Menu buttons ..... 79, 152–154
  - Menu layouts (page) ..... 122, 124
  - Menu password, Password, menu ..... 120
  - Menu selections ..... 28, 42, 53, 79–80
  - Menus ..... 33, 45, 47–48, 58, 61, 63, 66–67, 70, 72, 74,
    - ..... 76–77, 87, 123–124
    - automatic navigation to ..... 117
    - customer-defined ..... 79
    - deleting ..... 123
    - system-defined ..... 79
    - XG select ..... 12
  - Messages
    - error ..... 29–30, 34, 44, 54, 58
    - status ..... 29–30, 34, 44, 54, 58
    - system status ..... 142
  - Meter output ..... 12, 14–15, 63, 74
  - Metering input ..... 106, 134
  - Meters (button) ..... 149
  - Meters, audio ..... 12, 59, 63, 67, 70, 74, 80
  - Middle East, contact ..... 211
  - Miranda
    - technical support ..... 98
  - Miranda, contact ..... 211
  - Mixer/keyers ..... 10, 14
  - Mode
    - bypass ..... 11
    - clear preset after transition ..... 12
    - flip-flop ..... 82, 144, 197
    - flip-only ..... 82, 117, 144, 197
  - Modifiable buttons ..... 82
  - Modified compact enhanced control panel
    - see CECP M1
  - Modified GUI
  - Modifying a configuration file
    - active ..... 101
    - stored ..... 102
  - Modifying a stored configuration ..... 101–102
  - Modifying an active configuration ..... 101
  - Modules, Dolby E, optional ..... 12
  - Monitor
    - output ..... 35, 59, 63, 65, 67, 70, 74
    - section ..... 42
  - Monitor A (button) ..... 149
  - Monitor B (button) ..... 149
  - Monitor section ..... 27, 52
  - Monitor wall (page) ..... 177
  - Monitor, iMC-Panel-100 ..... 43
  - Monitors
    - A ..... 28, 35, 52, 146
    - audio ..... 12, 28, 35, 52, 59, 63, 67, 70, 74, 80, 146
    - B ..... 28, 35, 52, 146
    - buses ..... 80
  - Mounting, control panel ..... 9–10
  - Multi-format router (MFR) ..... 7
  - Multi-viewer ..... 21, 107, 117, 143
  - Mutually exclusive button set .. 29, 33, 43, 47, 53, 58, 63,
    - ..... 66, 70, 73, 76, 80
- ## N
- Navigation buttons ..... 80, 124, 152–153
  - Network, master control ..... 30, 38, 45, 47, 55, 60–61, 68,
    - ..... 71–73, 75
  - New (command) ..... 88, 101, 105, 159
  - New configuration files ..... 101
  - New configurations ..... 101, 103, 158
  - New GUI
  - Next Page, Acrobat ..... 2
  - No channels (button) ..... 135, 182–183
  - None (logging level) ..... 112, 165
  - Not assigned (a button configuration option) ..... 134
  - NotePad ..... 112, 165
  - notice, use ..... ii
  - Number of main source buttons ..... 121, 173
  - NV5100MC, frame ..... 3, 7
  - NV5100MC-CECP ..... 9, 51, 61, 197
  - NV5100MC-CECP-M1 ..... 9

|                                |  |
|--------------------------------|--|
| NV5100MC-FECP .....            | 10, 58, 60, 197                          |
| NV5100MC-GUI .....             | 9, 62                                    |
| NV5100MC-SCP .....             | 10, 78, 198                              |
| NV5128-MC-CFCP .....           | 9, 64–66, 68, 197                        |
| NV5128-MC-FFCP .....           | 9, 33, 57, 69–72, 197                    |
| NV5128-MC-GUI .....            | 9, 61, 72–73, 75, 197                    |
| NV9000                         |  |
| router control system .....    | 4, 8, 82, 109, 135, 137, 163,<br>182–183 |
| salvo .....                    | 109, 137, 163, 183                       |
| system controller .....        | 112                                      |
| NV9000 settings (page) .....   | 112–113, 137, 171                        |
| NV9000 systems (command) ..... | 93                                       |

## O

|   |   |
|---|---|
| Obtaining technical support (command) ..... | 98  |
| Off-air                                     |   |
| inputs .....                                | 67  |
| office hours .....                          | 211   |
| Off-line work .....                         | 86  |
| Old GUI                                     |   |
| Open (command) .....                        | 89, 102   |
| Open file (command) .....                   | 100, 102  |
| Open is selected (option) .....             | 139, 185  |
| Output                                      |   |
| AES .....                                   | 10  |
| analog audio .....                          | 10, 14  |
| aux .....                                   | 27, 37, 49, 52, 127   |
| clean feed .....                            | 14–15   |
| GPI .....                                   | 138–139, 184–185, 194                                       |
| meter .....                                 | 12, 14–15   |
| relay .....                                 | 137–139, 184–185  |
| router .....                                | 10  |
| Outputs                                     |   |
| GPI .....                                   | 31, 38, 45, 55, 60, 68, 72                                  |
| meter .....                                 | 63, 74  |
| monitor .....                               | 35, 59, 63, 65, 67, 70, 74                                  |
| Over  |   |
| ratio .....                                 | 59, 67, 71, 79  |
| source .....                                | 70  |
| sources .....                               | 29, 33, 43, 54, 58, 150, 194                                |
| Over ratio buttons .....                    | 150   |
| Overs, audio .....                          | 12–13, 33, 37, 57, 59, 65–67, 70–71, 74,<br>78–79, 121, 172 |
| Overview                                    |   |
| MCS panel configuration editor .....        | 83  |
| system .....                                | 7   |
| Oxtel .....                                 | 3   |

## P

|                                       |  |
|---------------------------------------|--|
| Page                                  |  |
| advanced settings .....               | 114, 116, 166–167                            |
| audio monitoring layout .....         | 127, 129, 174                                |
| aux delegates .....                   | 125  |
| aux row .....                         | 175  |
| bottom row layout .....               | 110, 134, 164                                |
| button assignments .....              | 120, 172                                     |
| channel selection list .....          | 106, 160                                     |
| general settings .....                | 105, 159                                     |
| logging settings .....                | 111, 165                                     |
| menu layouts .....                    | 122, 124                                     |
| monitor wall .....                    | 177  |
| NV9000 settings .....                 | 112–113, 137, 171                            |
| preview/user .....                    | 176  |
| preview/user row .....                | 176  |
| user button layout .....              | 109–110, 134, 163                            |
| user menu lists .....                 | 122, 125, 153–154                            |
| welcome .....                         | 83   |
| Pages                                 |  |
| channel selection list .....          | 107  |
| Pages, configuration .....            | 84, 103–104, 157–158                         |
| Panel                                 |  |
| buttons .....                         | 67   |
| GPI .....                             | 12, 193                                      |
| IP address .....                      | 85, 96, 100–102                              |
| knobs .....                           | 31, 33, 48, 56, 58, 63, 65–67, 69–70, 74, 77 |
| LCD brightness .....                  | 118, 168                                     |
| lock .....                            | 79   |
| lock (button) .....                   | 60, 71                                       |
| maintenance .....                     | 29–30, 34, 44, 54, 58                        |
| right-click to add panel .....        | 98   |
| type .....                            | 21   |
| Panel (menu) .....                    | 123  |
| Panel GPI input (button) .....        | 138  |
| Panel GPI input/output (button) ..... | 138, 184                                     |
| Panel GPI output (button) .....       | 138, 184                                     |
| Panel ID (menu) .....                 | 71   |
| Panel list .....                      | 83, 85, 100                                  |
| Panel lock (button) .....             | 28, 37, 50, 53, 64, 68, 75, 78, 140, 186     |
| Panel menu, of control panel .....    | 100  |
| Panel restart .....                   | 86, 97, 102                                  |
| Panel sections                        |  |
| audio levels .....                    | 28, 42, 52                                   |
| configurable button .....             | 27, 34, 48, 52, 110, 146, 163                |
| configurable buttons .....            | 41   |
| label recess .....                    | 42   |
| monitors .....                        | 27, 42, 52                                   |
| system control .....                  | 28, 37, 50, 53, 140                          |
| transition .....                      | 28, 37, 50, 53                               |
| Panel tree .....                      | 83, 85, 100                                  |
| Panels (command) .....                | 92   |
| Panels, control .....                 | 3, 8, 83, 197                                |
| Parameters, adjusting .....           | 27, 35, 41, 48, 52                           |
| part number, document .....           | ii   |

Pathnames, Master Control applications ..... 87  
 Pause (button) ..... 153–154  
 PB cut (button) ..... 145  
 PB cut-fade (button) ..... 145  
 PB fade-cut (button) ..... 145  
 PB v-fade (button) ..... 145  
 PC GUI ..... 9  
 PC, configuration ..... 3  
 PDF documents  
   navigating and searching ..... 2  
 PDF file, usage ..... 2  
 PGM DVE enable (button) ..... 186, 189  
 PGM selected source color ..... 118  
 phone numbers ..... 211  
 Physical main source buttons ..... 121  
 Play (button) ..... 153  
 Port  
   Ethernet ..... 81  
   USB ..... 30, 37, 44, 54, 60  
 Power connectors ..... 30, 32, 37, 44–45, 54–55, 57, 60,  
   ..... 66, 68–69, 71, 81  
 Pre-roll ..... 15, 153–154  
 Pre-roll (button) ..... 153–154  
 Pre-roll point ..... 153  
 Pre-select, router ..... 8, 21, 82, 151  
 Preset  
   bus ..... 12, 36–37, 59, 65, 67, 71, 74, 79  
   buttons ..... 120  
 Preset Dolby-E control (button) ..... 147  
 Preset Dolby-E status (button) ..... 147  
 Preset main audio level (button) ..... 150  
 Preset main button map (button) ..... 151  
 Preset main router (button) ..... 151  
 Preset over audio level (button) ..... 150  
 Preset over audio ratio (button) ..... 150  
 Preset over button map (button) ..... 151  
 Preset squeeze background ..... 126  
 Preset squeeze image2 ..... 126  
 Preset tally ..... 20  
 Preview bus ..... 26–27, 36–37, 49–50, 52, 59, 63–64,  
   ..... 77, 120–121, 126  
 Preview buttons ..... 9, 49, 89, 147  
 Preview cards ..... 15  
 Preview Int XG (button) ..... 12  
 Preview squeeze background ..... 126  
 Preview squeeze image2 ..... 126  
 Preview/user buttons ..... 26, 36, 49, 85  
 Preview/user row (page) ..... 176  
 Previous Page, Acrobat ..... 2  
 Processing module, master control ..... 2–3  
 Processor, tally ..... 4, 11  
 Program  
   bus ... 12, 26, 36–37, 49, 59, 65, 67, 71, 74, 78–79, 194  
   buttons ..... 120  
 Program bus ..... 42  
 Program Dolby-E control (button) ..... 147

Program Dolby-E status (button) ..... 147  
 Program main audio level (button) ..... 150  
 Proxy, button ..... 135–141, 143–155, 182–192  
 PS1, FFCP ..... 71  
 PS2, FFCP ..... 71  
 PST DVE enable (button) ..... 186, 189  
 PST selected source color ..... 118

## R

Rate, transition ..... 28–30, 34, 37, 42, 44, 50, 53–54, 58,  
   ..... 60, 64, 67, 71, 75, 79–80, 146, 192  
 Ratio, over ..... 59, 67, 71, 79  
 Read config from panel (command) ..... 86, 91, 95, 101  
 Read configuration file from panel (dialog) ..... 91  
 Read log from panel (command) ..... 112, 165  
 Ready (button) ..... 153–154  
 Redundant  
   power supplies ..... 71  
 Relay  
   emergency bypass ..... 144, 193  
   GPI ..... 194  
   output ..... 137–139, 184–185  
 Rename (command) ..... 99  
 Restarting the panel ..... 86, 97, 102  
 restrictions ..... iii  
 Retrieving logs from a GUI ..... 112, 165  
 revision, document ..... ii  
 Rewind (button) ..... 153  
 Right-click  
   to add panel ..... 98  
   to change IP address ..... 100  
 RJ-45 connectors ..... 30, 32, 37–38, 44–45, 54–55, 57,  
   ..... 60, 66, 68–69, 71  
 RoHS ..... iii  
 Rotary encoders (knobs) ..... 78  
 Router  
   categories ..... 113  
   control system ..... 8, 82, 109, 135, 137, 163, 182–183  
   control system, NV9000 ..... 8  
   multi-format ..... 7  
   output cards ..... 10  
   pre-select ..... 8, 21, 82, 151  
   sources ..... 29, 33, 43, 54, 58

## S

safeguards ..... iii  
 safety notices ..... iii  
 Salvo (button) ..... 137, 183  
 Salvo IDs ..... 109, 137, 163  
 Salvos ..... 27, 34, 48, 52, 109, 135, 137, 163, 182–183  
 Save (command) ..... 89, 101–102  
 Save as (command) ..... 89, 101–102

SB0075 .....123

SCP (simple control panel) .... 2, 10, 78–79, 94, 109, 114,  
.....122, 124, 142, 149–151, 153, 198  
    dimensions ..... 78

Scroll bar ..... 52

Scrolling .....79, 81

SD video ..... 10

Search for devices (command) ..... 92

Search, Acrobat ..... 2

Secondary  
    system functions .....59, 63, 67, 70, 74, 77

Section  
    audio monitor ..... 59, 63, 67, 70, 74

Selection ..... 79  
    bank .....144  
    channel .....27, 29–30, 33–34, 44, 48, 52, 54, 58, 63,  
    .....67, 74, 77, 79, 81, 135, 182  
    menu ..... 28, 42, 53, 79–80

Selection, DSK ..... 30, 34, 44

Selection, DVE ..... 26, 30, 34, 36, 44, 49, 172

Set all to defaults (command) ..... 94

Settings  
    audio ..... 63, 74, 77  
    keyer .. 27, 33–34, 47–48, 52, 58, 63, 66, 70, 74, 76–77  
    NV9000 ..... 112–113, 171  
    squeezeback ..... 27, 34, 48, 52, 63, 74, 77  
    video effect ..... 29, 34, 43, 54, 58

Show all devices (option) ..... 92

Simple control panel  
    see SCP

Skip next (button) .....192

Slow (button) ..... 146, 192

Slow transition .....13, 68, 71, 75

Software and documentation CD (SB0075) .....3, 123

Software control panel  
    see GUI

software license .....iii

Software version ..... 97

Source  
    audio ..... 67  
    main .. 33, 37, 47, 57, 59, 62, 65–67, 70–71, 73–74, 76  
    over ..... 70

Source groups .....119

Source to button mapping ..... 79, 151

Sources  
    main ..... 12, 26, 28–30, 33–34, 36, 42–44, 48–49, 51,  
    ..... 53–54, 58–59, 64, 78–80, 150, 194  
    over .....29, 33, 43, 54, 58, 150, 194  
    router ..... 29, 33, 43, 54, 58

Special messages, symbol for ..... 2

Squeeze .....126

Squeezeback ..... 10, 13–14, 37, 59, 67, 71, 74, 79  
    settings ..... 27, 34, 48, 52, 63, 74, 77

Start in flip-flop mode (option) .....117

Status  
    buttons ..... 29, 33, 43, 53, 57, 62, 79–80  
    messages ..... 29–30, 34, 44, 54, 58

Stop (button) ..... 153

Stored configuration files ..... 102

Subnet mask ..... 30, 38, 45, 55, 60, 68, 71

Summary, MCE .....15

support, contact ..... 211

SWB .....4

Symbols .....2  
    example .....2  
    special message .....2

symbols, meaning ..... iv

System  
    buttons ..... 37, 50, 60, 64, 68, 71, 75, 78

System control (section) .....28, 37, 50, 53, 140

System controller, NV9000 ..... 112

System events (logging level) .....112, 165

System functions ..... 124

System overview .....7

System status (button) ..... 140, 142–143

System status messages ..... 142

## T

Tabbed work area ..... 84, 101–103, 157

Table of buttons .....121, 173

Take next (button) ..... 192

Take primary (button) ..... 190

Take secondary (button) ..... 191

Tally processor ..... 4, 11

Tally, high, low ..... 29, 33, 43, 45, 47, 57, 61–62, 66, 70,  
    .....72–73, 75–76

Tally, preset .....20

Technical support .....98

technical support ..... 211

Text, button . 29, 33, 43, 45, 57, 61, 65–66, 70, 72, 75, 142

Thumbnails ..... 108

Title bar .....84

TLA (transition lever arm) .....13, 32, 66, 68–69

Toggle buttons ..... 29, 33, 43, 53, 80, 138, 140–141,  
    ..... 144–147, 184, 186, 188–189, 191

Toggles ..... 33, 47, 58, 62, 66, 70, 73, 76

Tools (menu) .....87

Touchscreen .....9, 25, 27, 29, 31, 33, 40, 45, 51–52, 54,  
    ..... 56, 58, 61, 65–67, 69–70, 72

Touchscreen, PC .....9

trademarks ..... iii

Transactions (logging level) .....112, 165

Transition ..... 198  
    button ..... 33, 48, 58, 63, 66, 70, 74, 77  
    buttons .....67  
    clear preset after .....12  
    control .....67  
    fast ..... 13, 68, 71, 75

manual ..... 13  
 medium ..... 13, 68, 71, 75  
 processor, see MCE  
 processor, see MCPM  
 rate ..... 28–30, 34, 37, 42, 44, 50, 53–54, 58, 60, 64,  
     ..... 67, 71, 75, 79–80, 146, 192  
 rate buttons ..... 146, 192  
 slow ..... 13, 68, 71, 75  
 type ..... 13, 28, 37, 42, 50, 53, 60, 64, 66–67, 70–71,  
     ..... 75, 79–80, 145, 191  
 type, buttons ..... 145, 191  
 Transition (button) ..... 28, 37, 50, 53, 60, 64, 78, 80  
 Transition (section) ..... 28, 37, 50, 53  
 Transition button ..... 42  
 Transition hold (button) ..... 140–141  
 Transition lever arm (TLA) ..... 13, 32, 66, 68–69  
 Transitions ..... 79, 194  
     FTB ..... 13  
 Tree area ..... 84  
 Tree, master control ..... 98  
 Tree, panel ..... 83, 85, 100  
 Type  
     GPI buttons ..... 138, 184  
     MCPM ..... 10  
     panel ..... 21, 103–105, 158–159  
     transition ..... 13, 28, 37, 50, 53, 60, 64, 66–67, 70–71,  
         ..... 75, 79–80, 145, 191  
 Type, transition ..... 42

## U

United Kingdom, contact ..... 211  
 Up/down arrows ..... 72, 74  
 Update config (button) ..... 86  
 Update panel software (command) ..... 95  
 Updating a GUI configuration ..... 102  
 Updating a hardware panel configuration ..... 102  
 USB port ..... 30, 37, 44, 54, 60  
 USB ports, iMC-Panel-100 ..... 44  
 User button layout (page) ..... 109–110, 134, 163  
 User menu lists (page) ..... 122, 125, 153–154  
 User's guide, chapter structure ..... 1  
 Utility button functions ..... 186, 190

## V

Version, software ..... 97  
 Vertigo XG ..... 11, 198  
 V-fade ..... 13, 64, 67, 71, 75  
 V-fade (button) ..... 145, 191  
 VGA port, iMC-Panel-100 ..... 44  
 Video  
     effects ..... 12–13, 26, 28, 33, 36–37, 42, 47, 49, 51, 53,  
         ..... 57, 59, 62, 64–67, 70–71, 73–74, 76, 78–80,  
             ..... 121, 172, 194  
     HD ..... 10  
     SD ..... 10  
 Video effect buttons ..... 26, 36, 41–42, 51, 59, 63, 120  
 Video effect settings ..... 29, 34, 43, 54, 58  
 Video effects ..... 82, 117  
 Video only (button) ..... 146  
 Virtual buttons ..... 67  
 Virtual main source buttons ..... 79, 121, 144  
 Voice-over buttons ..... 26, 36, 49, 172

## W

Warnings (logging level) ..... 112, 165  
 warnings, hardware ..... iv  
 warranty ..... iii  
 web site ..... 211  
 Welcome page ..... 83  
 Work area ..... 84, 101–103, 157  
 Working off-line ..... 86  
 Write config to panel (command) ..... 86, 89, 102  
 Write configuration to panel (dialog) ..... 89

## X

Xbuilder ..... 3, 12, 198  
 X-fade ..... 13  
 XG Keyer Control (button) ..... 12, 133, 154  
 XG keyer control buttons ..... 154  
 XG keyer layer ..... 51, 117  
 XG keyer layers ..... 26, 36, 48–49, 59, 64, 78–79  
 XG layer (button) ..... 12, 121–122  
 XG select menu ..... 12  
 XMedia ..... 3, 12, 198  
 XPlay ..... 12, 198  
 Xplay ..... 3  
 Xstudio ..... 3, 12, 198





## Miranda Technical Support

For technical assistance, please contact the Miranda Technical Support center nearest you:

### Americas

Office hours: 9:00 a.m. – 9:00 p.m. (EST)  
Telephone: +1-800-224-7882  
Fax: +1-514-335-1614  
E-mail: techsupp@miranda.com

### Asia

Office hours: 9:00 a.m. – 5:00 p.m. (GMT+8)  
Telephone: +852-2539-6987  
Fax: +852-2539-0804  
E-mail: asiotech@miranda.com

### Europe, Middle East, Africa, UK

Office hours: 9:00 a.m. – 6:00 p.m. (GMT)  
Telephone: +44 118 952 3444  
Fax: +44 118 952 3401  
E-mail: eurotech@miranda.com

### China

Telephone: +86-10-5873-1814  
E-mail: asiotech@miranda.com

### France

Office hours: 9:00 a.m. – 5:00 p.m. (GMT+1)  
Telephone: +33 1 55 86 87 88  
Fax: +33 1 55 86 00 29  
E-mail: eurotech@miranda.com

## Corporate Head Office

Miranda Technologies Inc.

3499 Douglas-B.-Floreani, St-Laurent, Quebec, Canada H4S 2C6

Telephone: 514-333-1772  
Fax: 514-333-9828  
Web: [www.miranda.com](http://www.miranda.com)



---

A **BELDEN** BRAND