

Gecko Frames

8900 SIGNAL PROCESSING SYSTEM

Instruction Manual



071063605
NOVEMBER 2008



Affiliate with the N.V. KEMA in The Netherlands

CERTIFICATE

Certificate Number: 510040.001

The Quality System of:

Grass Valley, Inc.

400 Providence Mine Road
Nevada City, CA 95945
United States

15655 SW Greystone Ct.
Beaverton, OR 97006
United States

10 Presidential Way
3rd Floor, Suite 300
Woburn, MA 01801
United States

Nederland B.V.
4800 RP BREDA
The Netherlands

Weierstadt, Germany
Brunnenweg 9
D-64331 Weierstadt
Germany

Rennes, France
Rue du Clos Courtel
Cesson-Sevigne, Cedex
France

Technopole Brest Iroise
CS 73808
29238 Brest Cedex 3
France

17 rue du Petit Albi-BP 8244
95801 Cergy Pontoise
Cergy, France

2300 South Decker Lake Blvd.
Salt Lake City, UT 84119
United States

7140 Baymeadows Way
Suite 101
Jacksonville, FL 32256
United States

Including its implementation, meets the requirements of the standard:

ISO 9001:2000

Scope:

The design, manufacture and support of video hardware and software products and related systems.

This Certificate is valid until: June 14, 2009
This Certificate is valid as of: August 30, 2006
Certified for the first time: June 14, 2000

H. Pierre Sallé
President
KEMA-Registered Quality

The method of operation for quality certification is defined in the KEMA General Terms And Conditions For Quality And Environmental Management Systems Certifications. Integral publication of this certificate is allowed.

KEMA-Registered Quality, Inc.
4377 County Line Road
Chalfont, PA 18914
Ph: (215)997-4519
Fax: (215)997-3809

CRT 001 073004

Accredited By:
ANAB



Gecko Frames

8900 SIGNAL PROCESSING SYSTEM

Instruction Manual

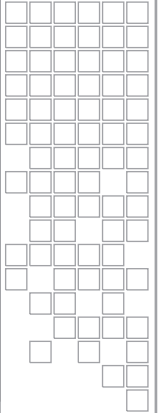
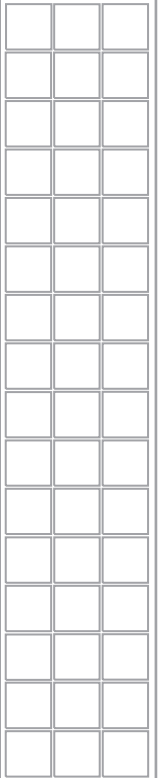
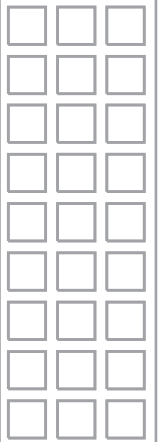

071063605
NOVEMBER 2008

Contacting Grass Valley

International Support Centers	France 24 x 7	+800 8080 2020 or +33 1 48 25 20 20 +800 8080 2020 or +33 1 48 25 20 20	United States/Canada 24 x 7	+1 800 547 8949 or +1 530 478 4148
Local Support Centers (available during normal business hours)	Asia	Hong Kong, Taiwan, Korea, Macau: +852 2531 3058 Indian Subcontinent: +91 22 24933476 Southeast Asia/Malaysia: +603 7805 3884 Southeast Asia/Singapore: +65 6379 1313 China: +861 0660 159 450 Japan: +81 3 5484 6868		
		Australia and New Zealand: +61 1300 721 495	Central/South America: +55 11 5509 3443	
		Middle East: +971 4 299 64 40 Near East and Africa: +800 8080 2020 or +33 1 48 25 20 20		
	Europe	Belarus, Russia, Tadzikistan, Ukraine, Uzbekistan: +7 095 2580924 225 Switzerland: +41 1 487 80 02 S. Europe/Italy-Roma: +39 06 87 20 35 28 -Milan: +39 02 48 41 46 58 S. Europe/Spain: +34 91 512 03 50 Benelux/Belgium: +32 (0) 2 334 90 30 Benelux/Netherlands: +31 (0) 35 62 38 42 1 N. Europe: +45 45 96 88 70 Germany, Austria, Eastern Europe: +49 6150 104 444 UK, Ireland, Israel: +44 118 923 0499		

Copyright © Thomson. All rights reserved.

This product may be covered by one or more U.S. and foreign patents.

Grass Valley Web Site

The www.thomsongrassvalley.com web site offers the following:

Online User Documentation — Current versions of product catalogs, brochures, data sheets, ordering guides, planning guides, manuals, and release notes in .pdf format can be downloaded.

FAQ Database — Solutions to problems and troubleshooting efforts can be found by searching our Frequently Asked Questions (FAQ) database.

Software Downloads — Download software updates, drivers, and patches.



END-OF-LIFE PRODUCT RECYCLING NOTICE

Grass Valley's innovation and excellence in product design also extends to the programs we've established to manage the recycling of our products. Grass Valley has developed a comprehensive end-of-life product take back program for recycle or disposal of end-of-life products. Our program meets the requirements of the European Union's WEEE Directive, the United States Environmental Protection Agency, and U.S. state and local agencies.

Grass Valley's end-of-life product take back program assures proper disposal by use of Best Available Technology. This program accepts any Grass Valley branded equipment. Upon request, a Certificate of Recycling or a Certificate of Destruction, depending on the ultimate disposition of the product, can be sent to the requester.

Grass Valley will be responsible for all costs associated with recycling and disposal, including freight. However, you are responsible for the removal of the equipment from your facility and packing the equipment to make it ready for pickup.



For further information on the Grass Valley product take back system please contact Grass Valley at + 800 80 80 20 20 or +33 1 48 25 20 20 from most other countries. In the U.S. and Canada please call 800-547-8949 or 530-478-4148, and ask to be connected to the EH&S Department. Additional information concerning the program can be found at: www.thomsongrassvalley.com/environment



Contents

Preface	7
About This Manual.....	7
Safety Terms and Symbols.....	9
Terms in This Manual.....	9
Terms on the Product.....	9
Symbols on the Product.....	10
Warnings.....	10
Cautions.....	11
Certifications and Compliances.....	21
FCC Emission Control.....	21
Canadian EMC Notice of Compliance.....	21
EN55022 Class A Warning.....	21
Canadian Certified Power Cords.....	22
Canadian Certified AC Adapter.....	22
Laser Compliance.....	22
Laser Safety Requirements.....	22
Laser Safety.....	22
FCC Emission Limits.....	23
Certification.....	23
Section 1 — Gecko 8900 Series Frames	25
Introduction.....	25
Frame Options and Upgrades.....	26
8900TX Convection System.....	27
8900TF Forced-air System.....	28
8900TFN Networked System.....	28
Frame Connections.....	29
Network Configuration Storage.....	31
Frame Cooling.....	31
Calculating Frame Power.....	32
Frame Monitor and Network Interface Modules.....	33
Section 2 — Installation	35
Introduction.....	35
Rack Mounting the Frame.....	35
Module and Power Supply Installation.....	36
Module Installation.....	36
Power Supply Installation.....	37
Rear Connectors.....	38
Loop-through Input Connectors.....	39
Direct Input/Output Connectors.....	39
Frame Alarm Connector.....	41
Frame Alarm Conditions.....	42

Frame Alarm Example	43
Section 3 — Power Up	45
Introduction.....	45
Power Connections	46
120 VAC	46
240 VAC	46
Line Cord Retainer	47
Applying Power	48
Section 4 — Monitoring and Control	49
Introduction.....	49
Frame Monitor Module	50
Enabling Alarms and Fan Speed Control Option	51
Frame Monitor Module Indicator LEDs	51
Section 5 — Specifications	53
Introduction.....	53
Frame Specifications	53
Power Supply	55
Appendix — 8900 Frames Archive	57
Introduction.....	57
Identifying Frame Types.....	57
Network Configuration Storage.....	57
Video Frame	58
SMPTE Alarm Connector	58
Audio Frame.....	61
Index	63

Preface

About This Manual

This manual provides installation and safety and regulatory information for the Gecko 8900 Series Video and Audio frames for housing Grass Valley 8900 Series modules.

An Appendix to this manual provides summary archive information on previously released 8900 frames.

Safety Summary

Read and follow the important safety information below, noting especially those instructions related to risk of fire, electric shock or injury to persons. Additional specific warnings not listed here may be found throughout the manual.

WARNING Any instructions in this manual that require opening the equipment cover or enclosure are for use by qualified service personnel only. To reduce the risk of electric shock, do not perform any servicing other than that contained in the operating instructions unless you are qualified to do so.

Safety Terms and Symbols

Terms in This Manual

Safety-related statements may appear in this manual in the following form:

WARNING Warning statements identify conditions or practices that may result in personal injury or loss of life.

CAUTION Caution statements identify conditions or practices that may result in damage to equipment or other property, or which may cause equipment crucial to your business environment to become temporarily non-operational.

Terms on the Product

The following terms may appear on the product:

DANGER — A personal injury hazard is immediately accessible as you read the marking.

WARNING — A personal injury hazard exists but is not immediately accessible as you read the marking.

CAUTION — A hazard to property, product, and other equipment is present.

Symbols on the Product

The following symbols may appear on the product:



Indicates that dangerous high voltage is present within the equipment enclosure that may be of sufficient magnitude to constitute a risk of electric shock.



Indicates that user, operator or service technician should refer to product manual(s) for important operating, maintenance, or service instructions.



This is a prompt to note fuse rating when replacing fuse(s). The fuse referenced in the text must be replaced with one having the ratings indicated.



Identifies a protective grounding terminal which must be connected to earth ground prior to making any other equipment connections.



Identifies an external protective grounding terminal which may be connected to earth ground as a supplement to an internal grounding terminal.



Indicates that static sensitive components are present which may be damaged by electrostatic discharge. Use anti-static procedures, equipment and surfaces during servicing.

Warnings

The following warning statements identify conditions or practices that can result in personal injury or loss of life.

Dangerous voltage or current may be present — Disconnect power and remove battery (if applicable) before removing protective panels, soldering, or replacing components.

Do not service alone — Do not internally service this product unless another person capable of rendering first aid and resuscitation is present.

Remove jewelry — Prior to servicing, remove jewelry such as rings, watches, and other metallic objects.

Avoid exposed circuitry — Do not touch exposed connections, components or circuitry when power is present.

Use proper power cord — Use only the power cord supplied or specified for this product.

Ground product — Connect the grounding conductor of the power cord to earth ground.

Operate only with covers and enclosure panels in place — Do not operate this product when covers or enclosure panels are removed.

Use correct fuse — Use only the fuse type and rating specified for this product.

Use only in dry environment — Do not operate in wet or damp conditions.

Use only in non-explosive environment — Do not operate this product in an explosive atmosphere.

High leakage current may be present — Earth connection of product is essential before connecting power.

Dual power supplies may be present — Be certain to plug each power supply cord into a separate branch circuit employing a separate service ground. Disconnect both power supply cords prior to servicing.

Double pole neutral fusing — Disconnect mains power prior to servicing.

Use proper lift points — Do not use door latches to lift or move equipment.

Avoid mechanical hazards — Allow all rotating devices to come to a stop before servicing.

Cautions

The following caution statements identify conditions or practices that can result in damage to equipment or other property

Use correct power source — Do not operate this product from a power source that applies more than the voltage specified for the product.

Use correct voltage setting — If this product lacks auto-ranging power supplies, before applying power ensure that the each power supply is set to match the power source.

Provide proper ventilation — To prevent product overheating, provide equipment ventilation in accordance with installation instructions.

Use anti-static procedures — Static sensitive components are present which may be damaged by electrostatic discharge. Use anti-static procedures, equipment and surfaces during servicing.

Do not operate with suspected equipment failure — If you suspect product damage or equipment failure, have the equipment inspected by qualified service personnel.

Ensure mains disconnect — If mains switch is not provided, the power cord(s) of this equipment provide the means of disconnection. The socket outlet must be installed near the equipment and must be easily accessible. Verify that all mains power is disconnected before installing or removing power supplies and/or options.

Route cable properly — Route power cords and other cables so that they are not likely to be damaged. Properly support heavy cable bundles to avoid connector damage.

Use correct power supply cords — Power cords for this equipment, if provided, meet all North American electrical codes. Operation of this equipment at voltages exceeding 130 VAC requires power supply cords which comply with NEMA configurations. International power cords, if provided, have the approval of the country of use.

Use correct replacement battery — This product may contain batteries. To reduce the risk of explosion, check polarity and replace only with the same or equivalent type recommended by manufacturer. Dispose of used batteries according to the manufacturer's instructions.

Troubleshoot only to board level — Circuit boards in this product are densely populated with surface mount technology (SMT) components and application specific integrated circuits (ASICs). As a result, circuit board repair at the component level is very difficult in the field, if not impossible. For warranty compliance, do not troubleshoot systems beyond the board level.

Sicherheit – Überblick

Lesen und befolgen Sie die wichtigen Sicherheitsinformationen dieses Abschnitts. Beachten Sie insbesondere die Anweisungen bezüglich Brand-, Stromschlag- und Verletzungsgefahren. Weitere spezifische, hier nicht aufgeführte Warnungen finden Sie im gesamten Handbuch.

WARNUNG Alle Anweisungen in diesem Handbuch, die das Abnehmen der Geräteabdeckung oder des Gerätegehäuses erfordern, dürfen nur von qualifiziertem Servicepersonal ausgeführt werden. Um die Stromschlaggefahr zu verringern, führen Sie keine Wartungsarbeiten außer den in den Bedienungsanleitungen genannten Arbeiten aus, es sei denn, Sie besitzen die entsprechende Qualifikationen für diese Arbeiten.

Sicherheit – Begriffe und Symbole

In diesem Handbuch verwendete Begriffe

Sicherheitsrelevante Hinweise können in diesem Handbuch in der folgenden Form auftauchen:

WARNUNG Warnungen weisen auf Situationen oder Vorgehensweisen hin, die Verletzungs- oder Lebensgefahr bergen.

VORSICHT Vorsichtshinweise weisen auf Situationen oder Vorgehensweisen hin, die zu Schäden an Ausrüstungskomponenten oder anderen Gegenständen oder zum zeitweisen Ausfall wichtiger Komponenten in der Arbeitsumgebung führen können.

Hinweise am Produkt

Die folgenden Hinweise können sich am Produkt befinden:

GEFAHR – Wenn Sie diesen Begriff lesen, besteht ein unmittelbares Verletzungsrisiko.

WARNUNG – Wenn Sie diesen Begriff lesen, besteht ein mittelbares Verletzungsrisiko.

VORSICHT – Es besteht ein Risiko für Objekte in der Umgebung, den Mixer selbst oder andere Ausrüstungskomponenten.

Symbole am Produkt

Die folgenden Symbole können sich am Produkt befinden:



Weist auf eine gefährliche Hochspannung im Gerätegehäuse hin, die stark genug sein kann, um eine Stromschlaggefahr darzustellen.



Weist darauf hin, dass der Benutzer, Bediener oder Servicetechniker wichtige Bedienungs-, Wartungs- oder Serviceanweisungen in den Produkthandbüchern lesen sollte.



Dies ist eine Aufforderung, beim Wechsel von Sicherungen auf deren Nennwert zu achten. Die im Text angegebene Sicherung muss durch eine Sicherung ersetzt werden, die die angegebenen Nennwerte besitzt.



Weist auf eine Schutzerdungsklemme hin, die mit dem Erdungskontakt verbunden werden muss, bevor weitere Ausrüstungskomponenten angeschlossen werden.



Weist auf eine externe Schutzerdungsklemme hin, die als Ergänzung zu einem internen Erdungskontakt an die Erde angeschlossen werden kann.



Weist darauf hin, dass es statisch empfindliche Komponenten gibt, die durch eine elektrostatische Entladung beschädigt werden können. Verwenden Sie antistatische Prozeduren, Ausrüstung und Oberflächen während der Wartung.

Warnungen

Die folgenden Warnungen weisen auf Bedingungen oder Vorgehensweisen hin, die Verletzungs- oder Lebensgefahr bergen.

Gefährliche Spannungen oder Ströme – Schalten Sie den Strom ab, und entfernen Sie ggf. die Batterie, bevor sie Schutzabdeckungen abnehmen, löten oder Komponenten austauschen.

Servicearbeiten nicht alleine ausführen – Führen Sie interne Servicearbeiten nur aus, wenn eine weitere Person anwesend ist, die erste Hilfe leisten und Wiederbelebungsmaßnahmen einleiten kann.

Schmuck abnehmen – Legen Sie vor Servicearbeiten Schmuck wie Ringe, Uhren und andere metallische Objekte ab.

Keine offen liegenden Leiter berühren – Berühren Sie bei eingeschalteter Stromzufuhr keine offen liegenden Leitungen, Komponenten oder Schaltungen.

Richtiges Netzkabel verwenden – Verwenden Sie nur das mitgelieferte Netzkabel oder ein Netzkabel, das den Spezifikationen für dieses Produkt entspricht.

Gerät erden – Schließen Sie den Erdleiter des Netzkabels an den Erdungskontakt an.

Gerät nur mit angebrachten Abdeckungen und Gehäuseseiten betreiben – Schalten Sie dieses Gerät nicht ein, wenn die Abdeckungen oder Gehäuseseiten entfernt wurden.

Richtige Sicherung verwenden – Verwenden Sie nur Sicherungen, deren Typ und Nennwert den Spezifikationen für dieses Produkt entsprechen.

Gerät nur in trockener Umgebung verwenden – Betreiben Sie das Gerät nicht in nassen oder feuchten Umgebungen.

Gerät nur verwenden, wenn keine Explosionsgefahr besteht – Verwenden Sie dieses Produkt nur in Umgebungen, in denen keinerlei Explosionsgefahr besteht.

Hohe Kriechströme – Das Gerät muss vor dem Einschalten unbedingt geerdet werden.

Doppelte Spannungsversorgung kann vorhanden sein - Schließen Sie die beiden Anschlußkabel an getrennte Stromkreise an. Vor Servicearbeiten sind beide Anschlußkabel vom Netz zu trennen.

Zweipolige, neutrale Sicherung – Schalten Sie den Netzstrom ab, bevor Sie mit den Servicearbeiten beginnen.

Fassen Sie das Gerät beim Transport richtig an - Halten Sie das Gerät beim Transport nicht an Türen oder anderen beweglichen Teilen fest.

Gefahr durch mechanische Teile – Warten Sie, bis der Lüfter vollständig zum Halt gekommen ist, bevor Sie mit den Servicearbeiten beginnen.

Vorsicht

Die folgenden Vorsichtshinweise weisen auf Bedingungen oder Vorgehensweisen hin, die zu Schäden an Ausrüstungskomponenten oder anderen Gegenständen führen können.

Gerät nicht öffnen – Durch das unbefugte Öffnen wird die Garantie ungültig.

Richtige Spannungsquelle verwenden – Betreiben Sie das Gerät nicht an einer Spannungsquelle, die eine höhere Spannung liefert als in den Spezifikationen für dieses Produkt angegeben.

Gerät ausreichend belüften – Um eine Überhitzung des Geräts zu vermeiden, müssen die Ausrüstungskomponenten entsprechend den Installationsanweisungen belüftet werden. Legen Sie kein Papier unter das Gerät. Es könnte die Belüftung behindern. Platzieren Sie das Gerät auf einer ebenen Oberfläche.

Antistatische Vorkehrungen treffen – Es gibt statisch empfindliche Komponenten, die durch eine elektrostatische Entladung beschädigt werden können. Verwenden Sie antistatische Prozeduren, Ausrüstung und Oberflächen während der Wartung.

CF-Karte nicht mit einem PC verwenden – Die CF-Karte ist speziell formatiert. Die auf der CF-Karte gespeicherte Software könnte gelöscht werden.

Gerät nicht bei eventuellem Ausrüstungsfehler betreiben – Wenn Sie einen Produktschaden oder Ausrüstungsfehler vermuten, lassen Sie die Komponente von einem qualifizierten Servicetechniker untersuchen.

Kabel richtig verlegen – Verlegen Sie Netzkabel und andere Kabel so, dass Sie nicht beschädigt werden. Stützen Sie schwere Kabelbündel ordnungsgemäß ab, damit die Anschlüsse nicht beschädigt werden.

Richtige Netzkabel verwenden – Wenn Netzkabel mitgeliefert wurden, erfüllen diese alle nationalen elektrischen Normen. Der Betrieb dieses Geräts mit Spannungen über 130 V AC erfordert Netzkabel, die NEMA-Konfigurationen entsprechen. Wenn internationale Netzkabel mitgeliefert wurden, sind diese für das Verwendungsland zugelassen.

Richtige Ersatzbatterie verwenden – Dieses Gerät enthält eine Batterie. Um die Explosionsgefahr zu verringern, prüfen Sie die Polarität und tauschen die Batterie nur gegen eine Batterie desselben Typs oder eines gleichwertigen, vom Hersteller empfohlenen Typs aus. Entsorgen Sie gebrauchte Batterien entsprechend den Anweisungen des Batterieherstellers.

Das Gerät enthält keine Teile, die vom Benutzer gewartet werden können. Wenden Sie sich bei Problemen bitte an den nächsten Händler.

Consignes de sécurité

Il est recommandé de lire, de bien comprendre et surtout de respecter les informations relatives à la sécurité qui sont exposées ci-après, notamment les consignes destinées à prévenir les risques d'incendie, les décharges électriques et les blessures aux personnes. Les avertissements complémentaires, qui ne sont pas nécessairement repris ci-dessous, mais présents dans toutes les sections du manuel, sont également à prendre en considération.

AVERTISSEMENT Toutes les instructions présentes dans ce manuel qui concernent l'ouverture des capots ou des logements de cet équipement sont destinées exclusivement à des membres qualifiés du personnel de maintenance. Afin de diminuer les risques de décharges électriques, ne procédez à aucune intervention d'entretien autre que celles contenues dans le manuel de l'utilisateur, à moins que vous ne soyez habilité pour le faire.

Consignes et symboles de sécurité

Termes utilisés dans ce manuel

Les consignes de sécurité présentées dans ce manuel peuvent apparaître sous les formes suivantes :

AVERTISSEMENT Les avertissements signalent des conditions ou des pratiques susceptibles d'occasionner des blessures graves, voire même fatales.

ATTENTION Les mises en garde signalent des conditions ou des pratiques susceptibles d'occasionner un endommagement à l'équipement ou aux installations, ou de rendre l'équipement temporairement non opérationnel, ce qui peut porter préjudice à vos activités.

Signalétique apposée sur le produit

La signalétique suivante peut être apposée sur le produit :

DANGER — risque de danger imminent pour l'utilisateur.

AVERTISSEMENT — Risque de danger non imminent pour l'utilisateur.

MISE EN GARDE — Risque d'endommagement du produit, des installations ou des autres équipements.

Symboles apposés sur le produit

Les symboles suivants peut être apposés sur le produit :



Signale la présence d'une tension élevée et dangereuse dans le boîtier de l'équipement ; cette tension peut être suffisante pour constituer un risque de décharge électrique.



Signale que l'utilisateur, l'opérateur ou le technicien de maintenance doit faire référence au(x) manuel(s) pour prendre connaissance des instructions d'utilisation, de maintenance ou d'entretien.



Il s'agit d'une invite à prendre note du calibre du fusible lors du remplacement de ce dernier. Le fusible auquel il est fait référence dans le texte doit être remplacé par un fusible du même calibre.



Identifie une borne de protection de mise à la masse qui doit être raccordée correctement avant de procéder au raccordement des autres équipements.



Identifie une borne de protection de mise à la masse qui peut être connectée en tant que borne de mise à la masse supplémentaire.



Signale la présence de composants sensibles à l'électricité statique et qui sont susceptibles d'être endommagés par une décharge électrostatique. Utilisez des procédures, des équipements et des surfaces antistatiques durant les interventions d'entretien.

Avertissements

Les avertissements suivants signalent des conditions ou des pratiques susceptibles d'occasionner des blessures graves, voire même fatales.

Présence possible de tensions ou de courants dangereux — Mettez hors tension, débranchez et retirez la pile (le cas échéant) avant de déposer les couvercles de protection, de défaire une soudure ou de remplacer des composants.

Ne procédez pas seul à une intervention d'entretien — Ne réalisez pas une intervention d'entretien interne sur ce produit si une personne n'est pas présente pour fournir les premiers soins en cas d'accident.

Retirez tous vos bijoux — Avant de procéder à une intervention d'entretien, retirez tous vos bijoux, notamment les bagues, la montre ou tout autre objet métallique.

Évitez tout contact avec les circuits exposés — Évitez tout contact avec les connexions, les composants ou les circuits exposés s'ils sont sous tension.

Utilisez le cordon d'alimentation approprié — Utilisez exclusivement le cordon d'alimentation fourni avec ce produit ou spécifié pour ce produit.

Raccordez le produit à la masse — Raccordez le conducteur de masse du cordon d'alimentation à la borne de masse de la prise secteur.

Utilisez le produit lorsque les couvercles et les capots sont en place — N'utilisez pas ce produit si les couvercles et les capots sont déposés.

Utilisez le bon fusible — Utilisez exclusivement un fusible du type et du calibre spécifiés pour ce produit.

Utilisez ce produit exclusivement dans un environnement sec — N'utilisez pas ce produit dans un environnement humide.

Utilisez ce produit exclusivement dans un environnement non explosible — N'utilisez pas ce produit dans un environnement dont l'atmosphère est explosible.

Présence possible de courants de fuite — Un raccordement à la masse est indispensable avant la mise sous tension.

Deux alimentations peuvent être présentes dans l'équipement — Assurez vous que chaque cordon d'alimentation est raccordé à des circuits de terre séparés. Débranchez les deux cordons d'alimentation avant toute intervention.

Fusion neutre bipolaire — Débranchez l'alimentation principale avant de procéder à une intervention d'entretien.

Utilisez les points de levage appropriés — Ne pas utiliser les verrous de la porte pour lever ou déplacer l'équipement.

Évitez les dangers mécaniques — Laissez le ventilateur s'arrêter avant de procéder à une intervention d'entretien.

Mises en garde

Les mises en garde suivantes signalent les conditions et les pratiques susceptibles d'occasionner des endommagements à l'équipement et aux installations.

N'ouvrez pas l'appareil — Toute ouverture prohibée de l'appareil aura pour effet d'annuler la garantie.

Utilisez la source d'alimentation adéquate — Ne branchez pas ce produit à une source d'alimentation qui utilise une tension supérieure à la tension nominale spécifiée pour ce produit.

Assurez une ventilation adéquate — Pour éviter toute surchauffe du produit, assurez une ventilation de l'équipement conformément aux instructions d'installation. Ne déposez aucun document sous l'appareil – ils peuvent gêner la ventilation. Placez l'appareil sur une surface plane.

Utilisez des procédures antistatiques - Les composants sensibles à l'électricité statique présents dans l'équipement sont susceptibles d'être endommagés par une décharge électrostatique. Utilisez des procédures, des équipements et des surfaces antistatiques durant les interventions d'entretien.

N'utilisez pas la carte CF avec un PC — La carte CF a été spécialement formatée. Le logiciel enregistré sur la carte CF risque d'être effacé.

N'utilisez pas l'équipement si un dysfonctionnement est suspecté — Si vous suspectez un dysfonctionnement du produit, faites inspecter celui-ci par un membre qualifié du personnel d'entretien.

Acheminez les câbles correctement — Acheminez les câbles d'alimentation et les autres câbles de manière à ce qu'ils ne risquent pas d'être endommagés. Supportez correctement les enroulements de câbles afin de ne pas endommager les connecteurs.

Utilisez les cordons d'alimentation adéquats — Les cordons d'alimentation de cet équipement, s'ils sont fournis, satisfont aux exigences de toutes les réglementations régionales. L'utilisation de cet équipement à des tensions dépassant les 130 V en c.a. requiert des cordons d'alimentation qui satisfont aux exigences des configurations NEMA. Les cordons internationaux, s'ils sont fournis, ont reçu l'approbation du pays dans lequel l'équipement est utilisé.

Utilisez une pile de remplacement adéquate — Ce produit renferme une pile. Pour réduire le risque d'explosion, vérifiez la polarité et ne remplacez la pile que par une pile du même type, recommandée par le fabricant. Mettez les piles usagées au rebut conformément aux instructions du fabricant des piles.

Cette unité ne contient aucune partie qui peut faire l'objet d'un entretien par l'utilisateur. Si un problème survient, veuillez contacter votre distributeur local.

Regulatory Notices

Certifications and Compliances

FCC Emission Control

This equipment has been tested and found to comply with the limits for a Class A digital device, pursuant to Part 15 of the FCC Rules. These limits are designed to provide reasonable protection against harmful interference when the equipment is operated in a commercial environment. This equipment generates, uses, and can radiate radio frequency energy and, if not installed and used in accordance with the instruction manual, may cause harmful interference to radio communications. Operation of this equipment in a residential area is likely to cause harmful interference in which case the user will be required to correct the interference at his own expense. Changes or modifications not expressly approved by Grass Valley Group can affect emission compliance and could void the user's authority to operate this equipment.

Canadian EMC Notice of Compliance

This digital apparatus does not exceed the Class A limits for radio noise emissions from digital apparatus set out in the Radio Interference Regulations of the Canadian Department of Communications.

Le présent appareil numérique n'émet pas de bruits radioélectriques dépassant les limites applicables aux appareils numériques de la classe A prescrites dans le Règlement sur le brouillage radioélectrique édicte par le ministère des Communications du Canada.

EN55022 Class A Warning

In a domestic environment, products that comply with Class A may cause radio interference in which case the user may be required to take adequate measures.

Canadian Certified Power Cords

Canadian approval includes the products and power cords appropriate for use in the North America power network. All other power cords supplied are approved for the country of use.

Canadian Certified AC Adapter

Canadian approval includes the AC adapters appropriate for use in the North America power network. All other AC adapters supplied are approved for the country of use.

Laser Compliance

Laser Safety Requirements

The device used in this product is a Class 1 certified laser product. Operating this product outside specifications or altering from its original design may result in hazardous radiation exposure, and may be considered an act of modifying or new manufacturing of a laser product under U.S. regulations contained in 21CFR Chapter 1, subchapter J or CENELEC regulations in HD 482 S1. People performing such an act are required by law to recertify and reidentify this product in accordance with provisions of 21CFR subchapter J for distribution within the U.S.A., and in accordance with CENELEC HD 482 S1 for distribution within countries using the IEC 825 standard.

Laser Safety

Laser safety in the United States is regulated by the Center for Devices and Radiological Health (CDRH). The laser safety regulations are published in the "Laser Product Performance Standard," Code of Federal Regulation (CFR), Title 21, Subchapter J.

The International Electrotechnical Commission (IEC) Standard 825, "Radiation of Laser Products, Equipment Classification, Requirements and User's Guide," governs laser products outside the United States. Europe and member nations of the European Free Trade Association fall under the jurisdiction of the Comité Européen de Normalization Electrotechnique (CENELEC).

For the CDRH: The radiant power is detected through a 7 mm aperture at a distance of 200 mm from the source focused through a lens with a focal length of 100 mm.

For IEC compliance: The radiant power is detected through a 7 mm aperture at a distance of 100 mm from the source focused through a lens with a focal length of 100 mm.

FCC Emission Limits

This device complies with Part 15 of the FCC Rules. Operation is subject to the following two conditions: (1) This device may not cause harmful interference, and (2) this device must accept any interference received, including interference that may cause undesirable operation. This device has been tested and found to comply with FCC Part 15 Class B limits for a digital device when tested with a representative laser-based fiber optical system that complies with ANSI X3T11 Fiber Channel Standard.

Certification

Category	Standard	Designed/tested for compliance with:
Safety	ANSI/UL60950	Safety of Information Technology Equipment, including Electrical Business Equipment (Third edition, 2000).
	IEC 60950	Safety of Information Technology Equipment, including Electrical Business Equipment (Third edition, 1999).
	CAN/CSA C22.2, No. 60950-00	Safety of Information Technology Equipment, including Electrical Business Equipment.
	BSEN60950	Safety of Information Technology Equipment, including Electrical Business Equipment.

Gecko 8900 Series Frames

Introduction

The Grass Valley Gecko™ 8900 Signal Processing System is a family of conversion, distribution, timing, and processing modules which provides support for a wide variety of signal processing applications.

Two Gecko 8900 Series frame types are available to support these modules:

- 8900 BNC/Video – providing BNC input/output connectors for video modules, and
- 8900 Balanced Audio – providing four BNC connectors and 10 three terminal audio connectors for balanced input/output connections for audio modules.

Note Refer to the documentation for each 8900 module for frame compatibility information.

Key features of the Gecko 8900 Series frames include:

- Support of all Grass Valley 8900 Series modules,
- Wide range of analog and digital functions,
- 10 module slots in each 2 RU frame,
- Analog/digital passive loop-through inputs,
- 100 W power supplies, each with independent AC main inputs and integrated cord retention,
- LEDs on front cover for fault and power supply status,
- Self-contained variable speed cooling,
- Ethernet control and monitoring,
- Serial interface for IP Address configuration and Frame Alarm output, and
- IP network identity stored in non-volatile frame memory.

The power usage of 8900 modules varies greatly from less complex analog to higher complexity digital modules. To handle these power requirements

and offer more control and monitoring flexibility, both frame types are offered in 8900TX, TF, and TFN models.

These models provide:

- 8900TX-V/TX-A – Vented cover for passive cooling and single 100 W power supply for modules outputting up to 30 W power,
- 8900TF-V/TF-A – Fan front cover with a variable fan speed mode and a single 100 W power supply, and
- 8900TFN-V/TFN-A – Fan front cover, 100W power supply, and Ethernet capability for remote control and monitoring using a web-based GUI (Graphical User Interface) with the 8900NET Network Interface Module.

An 8900 Video frame can house 8900 Series video modules and Grass Valley 8500 or 8800 analog distribution amplifiers (except the 8510R). The frame can house from one to ten 8900 video modules depending upon power requirements.

The 8900 Audio frame offers the same power, cooling, and control options as the 8900 Video frame while providing a backplane with three-terminal connectors for balanced audio inputs and outputs. Each audio module slot provides 10 three-terminal connectors and four BNC connectors for functions determined by the specific audio module installed.

Frame Options and Upgrades

Table 1 shows the Gecko 8900 Series frame models available. Table 2 provides the upgrade options available to extend the frame capabilities.

Table 1. Frame Models and Features

Model #	Cover type/power max.	Controller	Active Comm. Ports
8900TX-V/TX-A	Convection/30 Watts	None	None
8900TF-V/TF-A	Fan Front Cover/100 Watts	Frame Monitor Module	Frame Alarm
8900TFN-V/TFN-A	Fan Front Cover/100 Watts	8900NET Network Interface Module	Frame Alarm, RS-232, Ethernet

Table 2. Frame Upgrade Options and Features for Both Video and Audio Frames

Model #	Upgrade	Cover type/power max.	Controller	Active Comm. Ports
8900FAN	8900TX to 8900TF	Fan/100 Watts	Frame Monitor Module	Frame Alarm
8900FN	8900TX to 8900TFN	Fan/100 Watts	8900NET Network Interface Module	Frame Alarm, RS-232, Ethernet
8900NET	8900TF to 8900TFN	Fan/100 Watts	8900NET Network Interface Module	Frame Alarm, RS-232, Ethernet

8900TX Convection System

The convection system consists of the following:

- 8900TX-V/TX-A, convection frame, and one power supply
- 8900PSX, redundant power supply (optional)

The convection frame has a vented front cover and filter for convective air flow. This frame is used primarily for analog and a limited quantity of digital modules with a total power requirement less than 30 watts. Refer to [Frame Cooling on page 31](#).

The convection frame is illustrated in [Figure 1](#).

Figure 1. Convection Frame

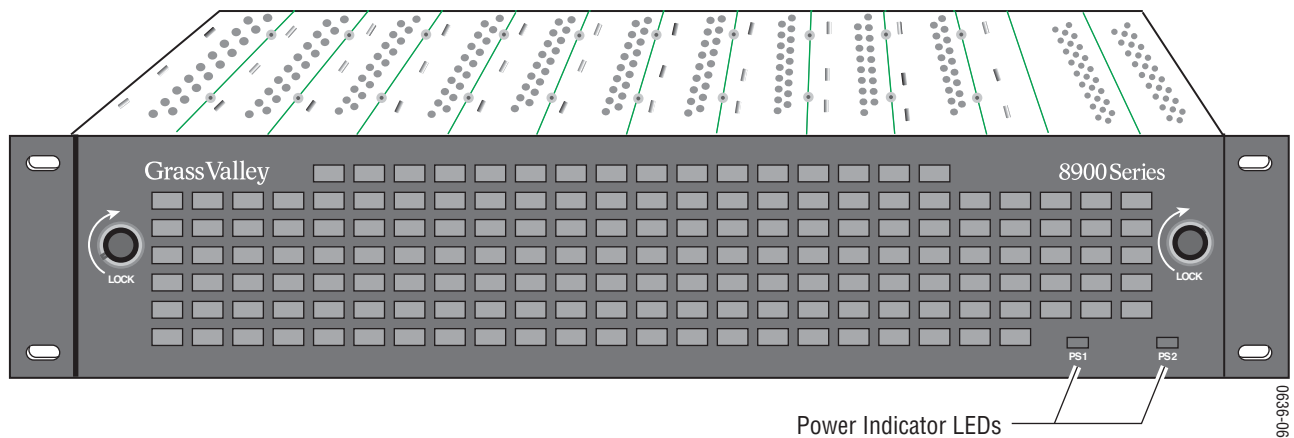

Note A convection frame can be upgraded to a forced-air or a networked frame. This requires the use of model 8900FAN retrofit kit which provides fans and the Fault indication window in the cover (see [Figure 2 on page 14](#)) and the 8900NET for networking capability.

8900TF Forced-air System

The forced-air system (Figure 2) consists of the following:

- 8900TF-V/TF-A, forced-air frame, Frame Monitor module, and one power supply
- 8900PSX, 100 W redundant power supply (optional)

The forced-air system has a front cover that is equipped with three fans for air circulation. The fan speed varies with the ambient frame temperature to extend fan life and reduce noise when the frame is used in cooler configurations and environments. The fan speed control voltage is generated on the Frame Monitor module and can be disabled so that the fan runs at maximum speed only. This frame is recommended for power requirements greater than 30 watts or when Frame alarm reporting (via the Frame Monitor module) is required. Refer to [Frame Cooling](#) on page 31.

Note A forced-air TF-V or TF-A frame can be converted to a networked TFN-V or TFN-A frame with the 8900NET option.

Figure 2. Forced-air or Networked Frame

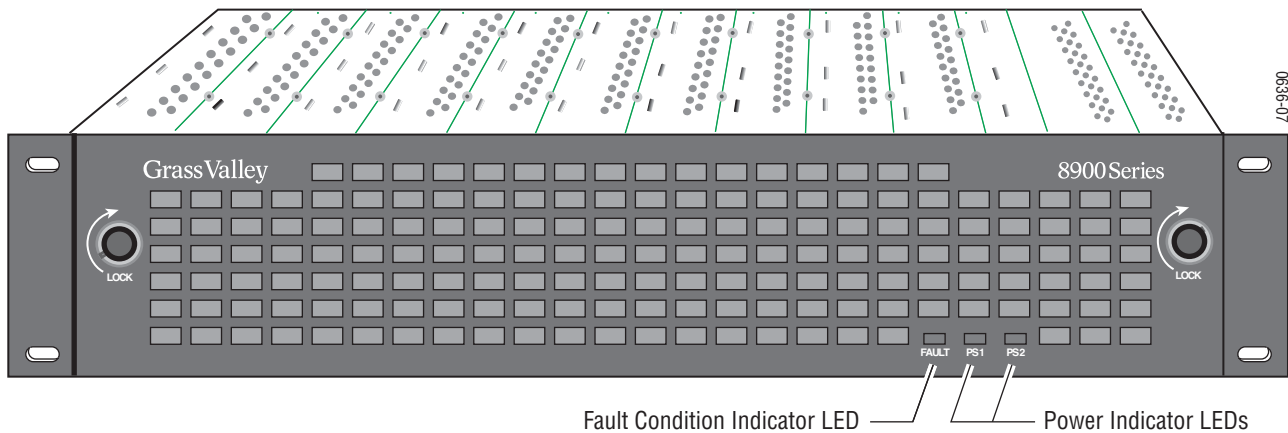

8900TFN Networked System

The networked system consists of the following:

- 8900TFN-V/TFN-A, forced-air frame, 8900NET Network Interface Module, and one power supply
- 8900PSX, 100 W redundant power supply (optional)

The networked system has the same features as the forced-air system including the fan cover (Figure 2) and fault and power indicators. Also included is the 8900NET Network Interface module allowing the frame to communicate over an Ethernet LAN to the web browser GUI interface for remote control of 8900 modules.

Frame Connections

Two types of connector backplanes are available in the Gecko 8900 Series frames. The 8900 BNC / Video frame provides ten module slots, each with a loop-through input and up to eight connectors for input/output functions as needed for a specific module type (Figure 3).

Figure 3. 8900 Video Frame Module I/O Connectors

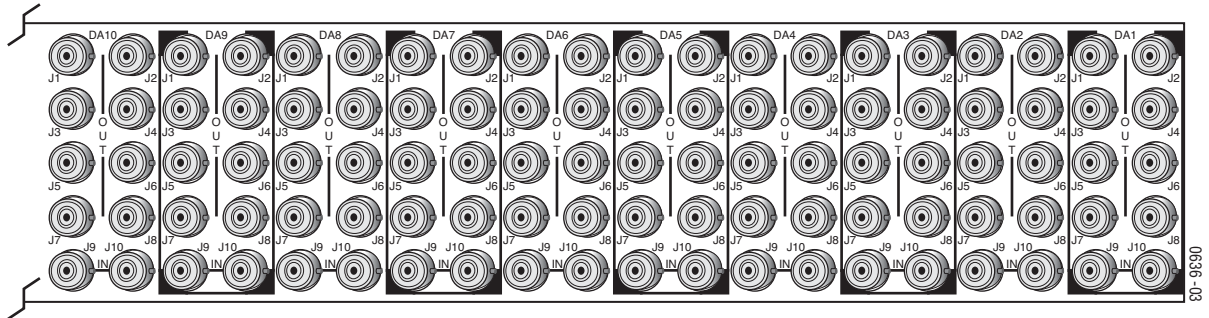

The 8900 Balanced Audio frame provides 10 three-terminal connectors and 4 BNC connectors (Figure 4). As in the Video frame, two of the BNCs are for loop-through connection.

Figure 4. 8900 Audio Frame Module I/O Connectors

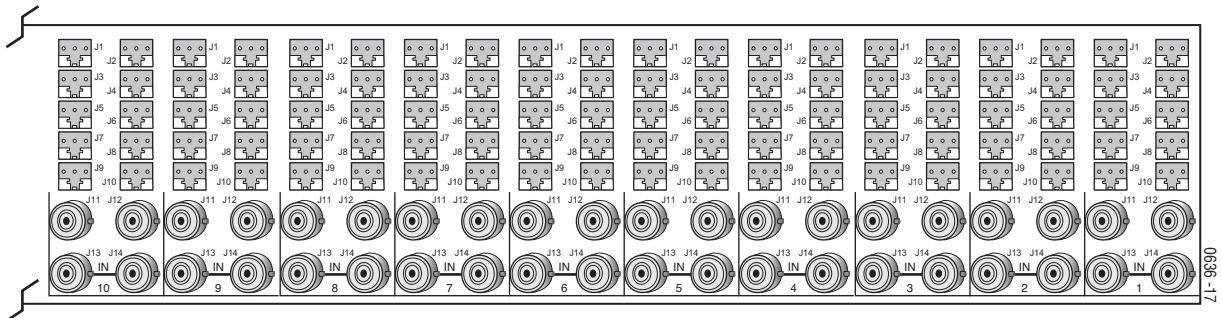

The power/communication backplane section of the frame (Figure 5 and Figure 6) provides:

- AC power plug connections
- DB-9 connector labeled RS-232 (requires the 8900NET module) with Frame Alarm connections (pins 8 and 9 of RS-232 connector)
- Ethernet RJ-45 connector (requires the 8900NET module)

The RS-232 port provides connection to a PC used for initial network configuration. Pins 8 and 9 of the RS-232 port can be used for Frame Alarm reporting. The RJ-45 Ethernet connector provides a 10Base-T Ethernet network connection with the 8900NET Network Interface module.

Figure 5. Power/Communication Connectors on 8900 Video/BNC Frames

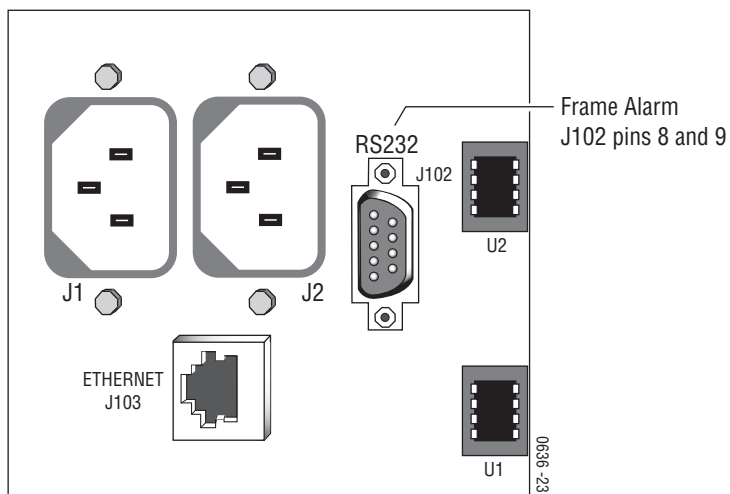
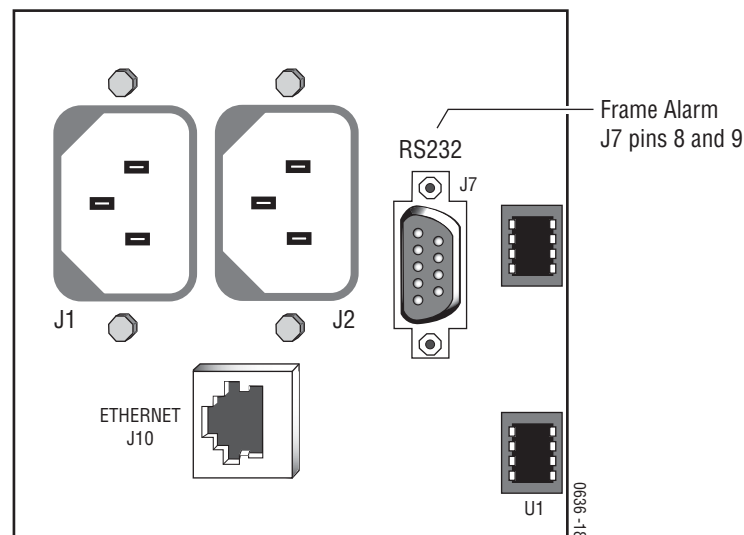

Figure 6. Power/Communication Connectors on 8900 Balanced Audio Frames



Network Configuration Storage

Both the 8900 BNC/Video and Balanced Audio frames are equipped with IP address storage capability on the rear backplane. When an 8900NET module is installed (with version 3.0 software or later), the IP address assignments made on the 8900NET module for network configuration are stored on the frame. The current network configuration information will then stay with the frame if the 8900NET module is moved.

Note Older version 8900 frames do not have IP address storage capability. IP address information is stored only on the 8900NET module. Refer to [Video Frame on page 58](#) for more information.

Frame Cooling

The convection frame and the forced-air frame provide a great deal of flexibility in the type of modules that can be installed. Conventional low power analog DAs can be used alongside higher power serial digital modules with all modules performing to their full specifications.

For installations that require only low power modules or modules that have a combined total dissipation of less than 30 watts, the convection frame will provide adequate cooling.

Note The 30 watt TX-A/-V frame is best used for modules with less than 5.5 watts power dissipation. When total power dissipation approaches maximum, provide as much space as possible between the modules.

For installations where the modules dissipate greater than 30 watts, a forced air frame must be used.

CAUTION Do not leave a fan front cover off of an air-cooled frame for extended periods. For reliable operation, the forced-air cover should not be removed for longer than five minutes when cooling more than 30 watts.

Calculating Frame Power

To calculate the power required for your frame, you must total all the power dissipated for each individual module.

Table 3 provides the power dissipation for many of the modules compatible with the 8900 Video and Audio frames. For newer modules not listed, refer to the Specifications table in the specific module instruction manual.

Table 3. Module Power Dissipation

Module	Power Dissipation	Module	Power Dissipation
All 8500 Modules	2 Watts	8920Mux	7 Watts
All 8800 Modules	2 Watts	8931	2 Watts
8910ADA-M/ST	3 Watts	8936	3 Watts
8910ADA-SR	5 Watts	8941	6 Watts
8911	3 Watts	8942	5 Watts
8912RDA/-D	4 Watts	8950ADC	7.2 Watts
8914	3.5 Watts	8950DAC	7.5 Watts
8916	6 Watts	8960DEC	6.5 Watts, 8.5 Watts with Frame Sync option
8920ADC	4.2 Watts	8960ENC	6.5 Watts, 8.5 Watts with Frame Sync option
8920ADT	6 Watts	8981FS	4.5 Watts
8920DAC	3.1 Watts	8990ARC	6.5 Watts
8920DMX	7 Watts		

Two examples of power calculations are shown in Table 4 and Table 5.

Table 4. Module Power Dissipation, example 1

Module	Quantity	Power Per Module	Total Power
8800	5	2 Watts	10 Watts
8960DEC without Frame Sync	2	6.5 Watts	13 Watts
8936	2	3 Watts	6 Watts
Total Frame Power			29 Watts

The total frame power required is less than 30 watts; therefore, the convection frame may be used.

Table 5. Module Power Dissipation, example 2

Module	Quantity	Power Per Module	Total Power
8836	1	3 Watts	3 Watts
8916	2	6 Watts	12 Watts
8960DEC without Frame Sync	3	6.5	19.5

Table 5. Module Power Dissipation, example 2

Module	Quantity	Power Per Module	Total Power
8941	4	6 Watts	24 Watts
Total Frame Power			58.5 Watts

With ten modules, the total frame power required is greater than 30 watts and an 8900TF or 8900TFN forced-air frame must be used.

Frame Monitor and Network Interface Modules

8900 frame configuration supports the use of either the Frame Monitor or the 8900NET Network Interface module. The Frame Monitor module provides alarm reporting for the Frame Alarm only. The 8900NET Network Interface module provides full functionality of the frame communication buses including:

- Frame Alarm,
- RS-232 Configuration, and
- 10Base-T Ethernet.

Refer to the *8900NET Network Interface Module Instruction Manual*.

Installation

Introduction

This section contains information about:

- Rack mounting the frame,
- Module and Power Supply installation,
- Rear connectors, and
- Frame Alarm.

Rack Mounting the Frame

After carefully unpacking this equipment, check the box for a power cords and other hardware, and examine the equipment for damage. Any damage should be promptly reported to the carrier.

The frame is designed to mount in a standard 19-inch equipment rack. Mounting space of 3.5 inches (89 mm) vertically and mounting depth of 14 inches (356 mm) are required. Mount the frame in a standard 19-inch rack using customer-supplied rack mounting screws.

CAUTION Before lifting the frame, verify that the power supplies are fully seated in their slots. Front ejector tabs should click into place when snapped on the locking pin on the module (see [Figure 7](#)).

Figure 7. Power Supply Ejector Tab Locking Pin

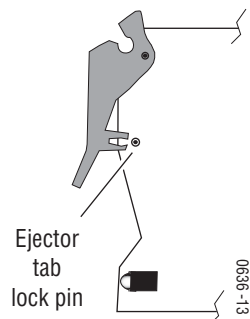

Module and Power Supply Installation

Module Installation

There are ten cell locations in each frame to accommodate either video or audio modules (module types cannot be mixed in a frame). These are the ten cells located on the left side of the frame. Refer to [Figure 8](#).

Modules can be configured for up to eight outputs. The 8500 modules have six outputs. The 8800 and 8900 modules have eight outputs. Refer to individual module manuals for input/output configuration information.

The two cells on the right are allocated for the power supplies only. The third cell from the right, is allocated only for the Frame Monitor or 8900NET Network Interface module. This module provides the interface for the forced-air cover, as well as the Frame Alarm reporting. For additional information concerning the Frame Monitor and Network Interface modules, refer to [Section 4-Monitoring and Control](#).

Figure 8. Gecko 8900 Series Frame

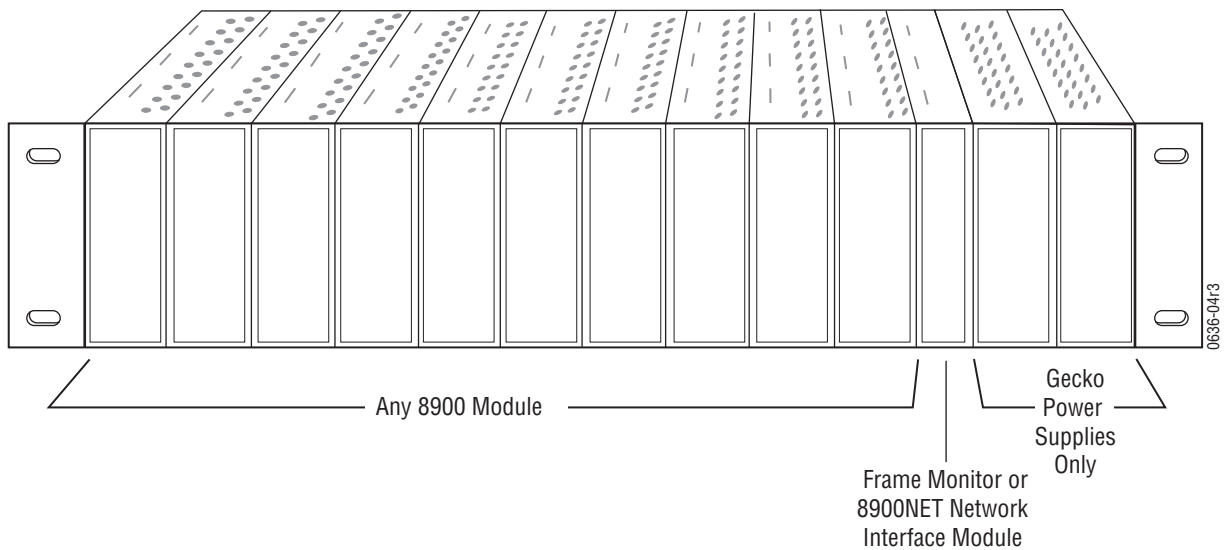

To install a module into the frame, follow these steps:

1. Insert the module into the frame, connector-end first, with component side of the module facing to the right with the ejector tab at the top. The Frame Monitor and the 8900NET module have a connector tab with a circular finger-hole for pulling the module rather than an ejector tab. The connector tab should be oriented in the top half of the frame.
2. Verify that the module connector seats properly against the backplane.
3. Press the ejector tab or connector tab in to seat the module in place.

Power Supply Installation

The frame will come with a single Gecko 100 Watt power supply installed in one of the slots on the far right. The currently shipping 100W Gecko Frame power supply with a protective front cover is similar to the one shown in [Figure 9](#).

If you have ordered a redundant power supply, install it in the empty cell on the far right of the frame (see the location drawing in [Figure 8 on page 36](#)), making sure the ejector tab locks into place.

Note Power supplies used in the 8900 Gecko frames (8900TF/TFN-A/-V) and the ones used in the GeckoFlex frames cannot be swapped. They are different lengths.

Figure 9. Power Supply Installation

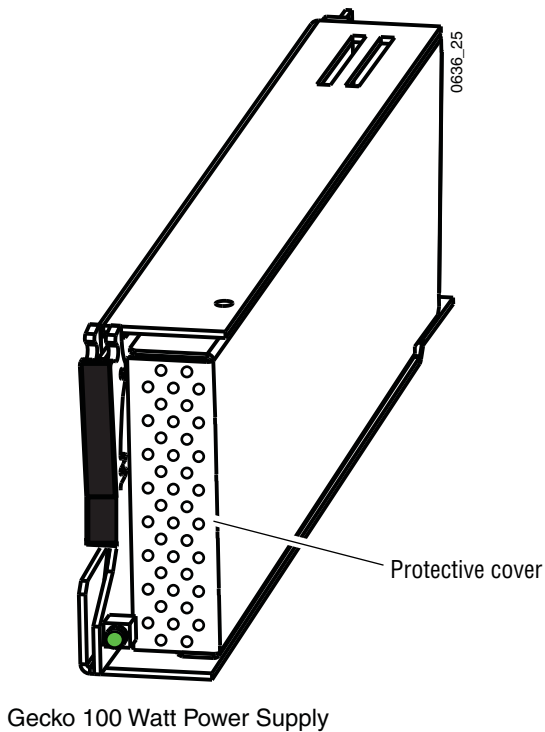

Rear Connectors

Modules may be configured for a variety of inputs and outputs. The 8500 modules have six outputs. The 8800 and 8900 modules have up to eight outputs. Refer to individual module manuals for specific configuration information.

Note Connector configuration overlays are available for many 8900 modules that do not use the standard DA configuration (one looping input and eight BNC outputs). These overlays are found at the back of the module Instruction Manual.

Figure 10 illustrates the rear backplane of the 8900 BNC/Video frame.

Figure 10. 8900 Series Rear Connector Plate

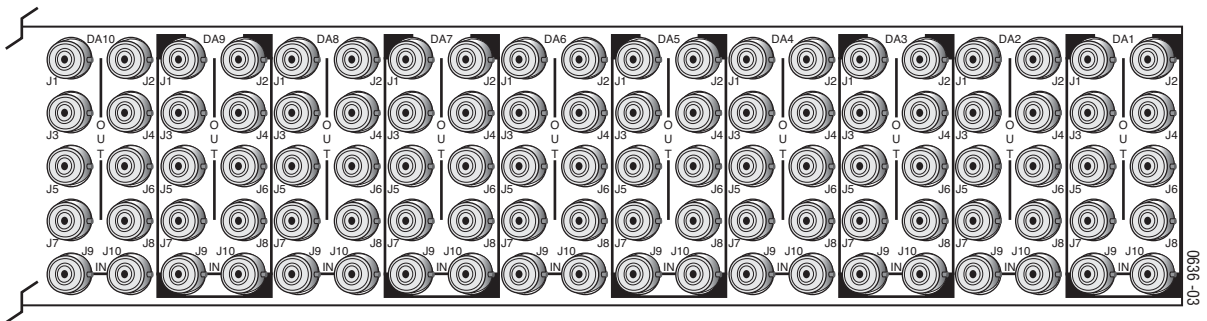
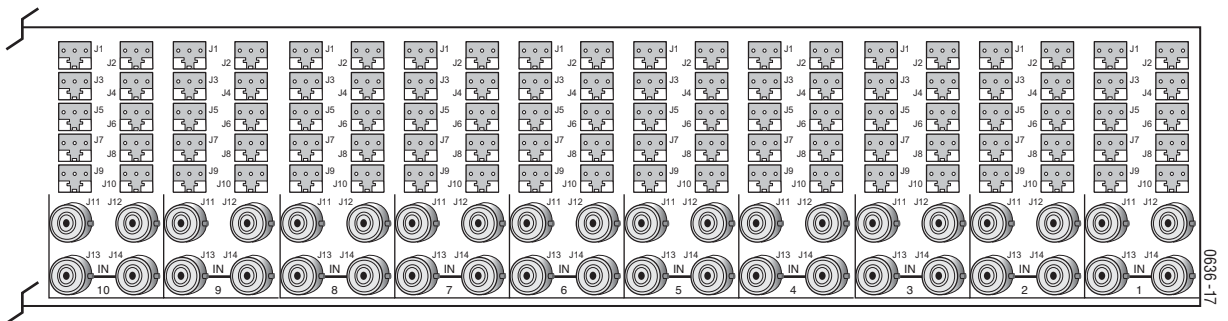

Figure 11 illustrates the 8900 Balanced Audio Frame three-terminal and BNC connectors on the rear backplane.

Figure 11. 8900 Series Audio Frame Rear Connector Plate



The rear connector backplane will be discussed in the following order:

- Loop-through Input
- Direct Input/Output Connectors
- Frame Alarm Connection

Loop-through Input Connectors

Input signals are routed through the rear of the frame. There is one loop-through input for each module cell refer to [Figure 10](#) and [Figure 11](#) on [page 38](#).

Note No more than five **digital** modules should be looped. Use cables less than two meters in length, and an input cable of less than 200 meters of Belden 8281 (or equivalent).

If not used for looping, the unused loop-through connector must be externally terminated. The recommended termination for serial digital signals is CONARE BCP-TA (or equivalent).

Performance of looping inputs to equipment other than 8900 modules has not been verified; monitor signal quality carefully when configuring such a system.

Serial digital video is a wideband RF signal. Be sure to protect the data from environmental noise. The serial digital signal is attenuated by as much as 30 dB after traveling through 1000 feet of 8281 cable. An equalizer must be used to restore the signal so data can be recovered. The equalizer boosts the serial digital video signal and any environmental noise on the line. Data corruption takes place if the environmental noise is large enough to cause pick-off errors in the equalizer.

When connecting serial digital video signals to and from the 8900 Series frame:

- Use high quality BNC connectors to ensure continuous shield connections.
- Use high quality cable (8281 or 1694A).
- Use one continuous cable for long cable runs. Avoid using patch panels or BNC barrel connectors.

Note These recommendations become even more important in noisy environments (subject to radio frequencies and static) with long cable runs.

Direct Input/Output Connectors

In the video frame (refer to [Figure 12](#)) there are eight direct (not looping) input/output BNC connectors provided for each module slot (J1 – J8). Refer to the Instruction Manual for the specific module for input/output connector information.

Note If 8500 modules are used in the frame, there are six outputs provided for each module, J1 through J6.

Figure 12. Video Frame Rear Input and Output Connector Labeling

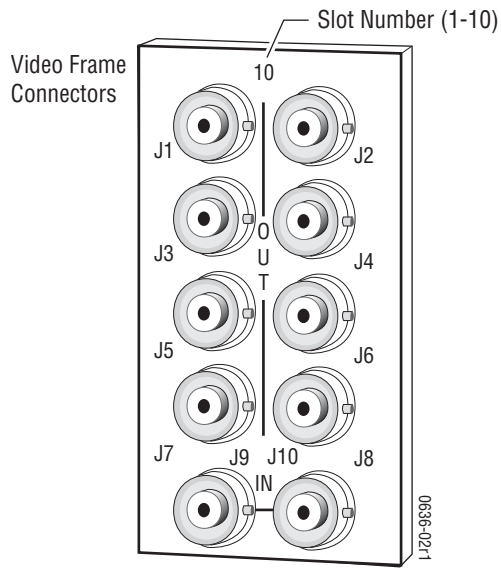

The audio frame provides two direct input/output BNCs (J11 and J12), two looping BNCs (J13 and J14), and ten three-terminal input/output connectors (J1 – J10) shown in Figure 13. A pack of 100 audio connectors is provided with the frame for connecting audio cable to the rear connectors. Refer to the specific audio module Instruction Manual for cabling information. Pinout information for each module may also be silkscreened on the module circuit board.

Figure 13. Audio Frame Rear Input and Output Connector Labeling

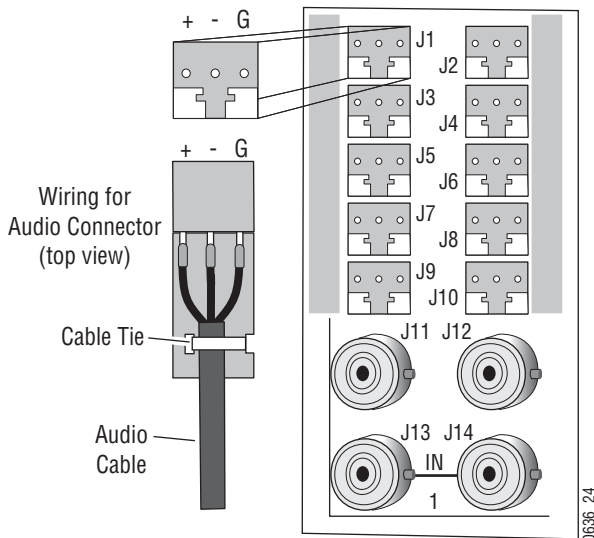

Frame Alarm Connector

Use of the Frame Alarm requires the presence of either the Frame Monitor or 8900NET Network Interface module in the frame. Frame Monitor module features are discussed in [Section 4-Monitoring and Control](#) in this manual. For information on the 8900NET module see the *8900 Network Interface Module Instruction Manual*.

The Frame Alarm is accessed through pins 8 and 9 of the RS-232 DB-9 connector (Video Frame – J102, Audio Frame – J7) as shown in [Figure 14](#). Refer to [Frame Alarm Example on page 43](#) for using the port in an alarm circuit.

Note Earlier model 8900 frames had a SMPTE ALARM BNC for accessing the Frame Alarm output. Refer to [SMPTE Alarm Connector on page 58](#) for cabling information on older frames.

Figure 14. Frame Alarm Connector Location

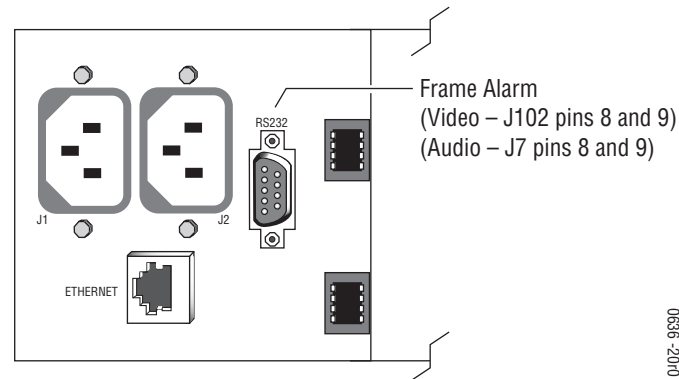

The pinout for the RS-232 DB-9F connector is given in [Table 6](#).

Table 6. RS-232 Connector Pinouts

Frame RS-232 Port	Pin	Video Frame – J102 Audio Frame – J7
	1	N/C
	2	TX
	3	RX
	4	N/C
	5	Gnd
	6	N/C
	7	N/C
	8	Frame Alarm
	9	Frame Alarm

Frame Alarm Conditions

The conditions monitored by Frame Alarm reporting are:

- Frame Health
 - Power supply 1 voltage
 - Power supply 2 voltage
 - Fan rotation
 - Frame temperature
- Module Health Bus (8900 Video Frames only)
 - Power supply voltage
 - Signal present at input
 - EQ warning

The Module Health bus provides a means for older (legacy) or less capable modules (such as DAs with no microprocessor) that cannot communicate over the Frame serial bus to report alarm conditions to the Frame Monitor or 8900NET module. The reporting is done using a voltage level sent by the module to the Frame Alarm connector. When a problem exists on the module, the Module Health bus will indicate that a problem exists on the module but will not indicate what the problem is.

Alarm conditions are enabled or disabled by using the Alarm Reporting DIP switch(es) on either the Frame Monitor or 8900NET modules. Refer to [Enabling Alarms and Fan Speed Control Option on page 51](#) for the Frame Monitor module. For information on setting the 8900NET switches, refer to the *8900 Network Interface Module Instruction Manual*.

In addition to fault reporting through the Frame Alarm connector, there is a red Fault LED on the 8900TF/TFN front cover. This LED is off when no fault conditions are detected and on when either an internal fault or a signal error is detected.

Frame Alarm Example

Refer to [Figure 15](#) for an example of a typical alarm schematic using pins 8 and 9 of the RS-232 port.

Figure 15. Typical Alarm Schematic for Frame Alarm

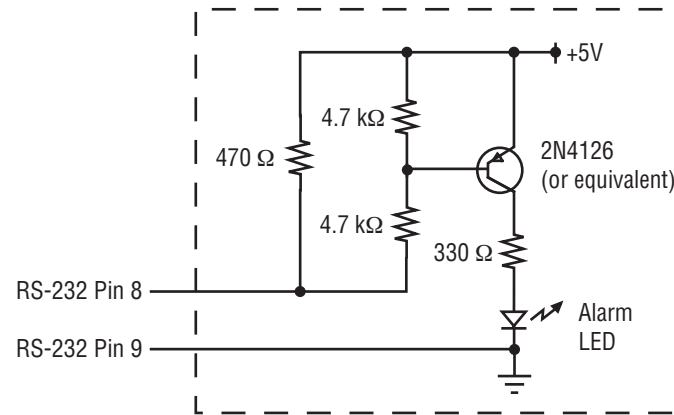

The impedance between the pins 8 and 9 of the RS-232 connector can be in one of two states:

- Open – less than 100 μA of current will flow with 5 volts across the pins, and
- Closed – less than 0.2 V will appear from pin 8 to pin 9 with 20 mA of current flowing.

There are three operational conditions (capability is module dependent, refer to specific module instruction manual):

- Open – no faults,
- Closed – there is an internal fault, and
- Pulsing – there is a missing or invalid signal on one or more of the modules.

Power Up

Introduction

This section contains information about:

- Power Connections
- Applying Power

CAUTION Verify that the power supplies are fully seated in their slots. Ejector tabs should click into place when snapped on the locking pin on the module (see [Figure 16](#)).

Figure 16. Power Supply Ejector Tab Locking Pin

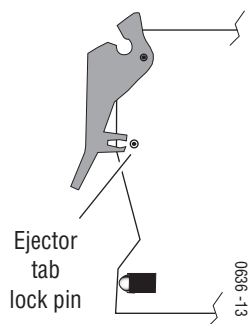

Power Connections

There are two types of power cords supplied with the 8900 Series frames for 120 V and 240 V operation. Line voltage selection is not required for this power supply. Optional redundant power supplies are also shipped with both types of power cord.

120 VAC

This cord has a molded grounding plug at one end and a molded grounded receptacle at the other end. Conductors are color-coded white (neutral), black (line), and green or green/yellow (ground).

240 VAC

This cord has a molded grounding receptacle at one end and stripped conductors at the other end. Conductors are color-coded light blue (neutral), brown (line), and green/yellow (ground).

For each power supply installed, AC power is fed through a line cord to a socket (J1 and J2) on the rear of the frame ([Figure 17](#)).

Figure 17. AC Power Connectors

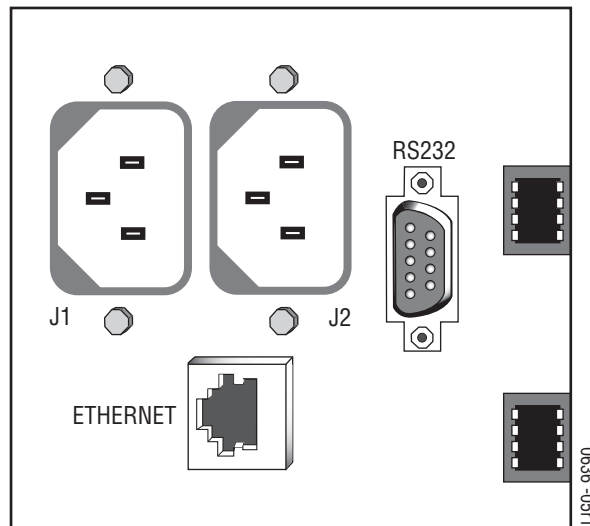

Note To maintain maximum redundant power, ensure that each power supply cord is plugged into a separate branch circuit.

Line Cord Retainer

To help prevent accidental loss of power, the AC line cord is held in place by a retainer clip (Figure 18).

Figure 18. Cable Retainer Clip

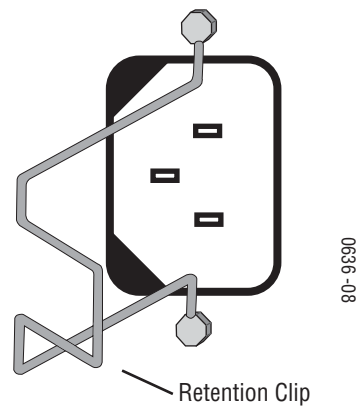

To properly install the line cord, follow these steps:

1. Ensure that the retainer clip is inserted properly into the holes of the screw caps.
2. Rotate the retainer clip sideways, and plug the power cord into the receptacle.
3. Rotate the retainer clip back onto the plug body to hold the power cord in place.

Applying Power

Upon applying power to the frame, verify that the green power LED for each power supply (assuming a redundant supply is present) PS1 and PS2 is illuminated (Figure 19). If the frame is a TF or TFN model (with fans), check the red FAULT LED. It should be off if the fans are operating correctly.

Figure 19. Power Indicator LEDs (TF frame shown)

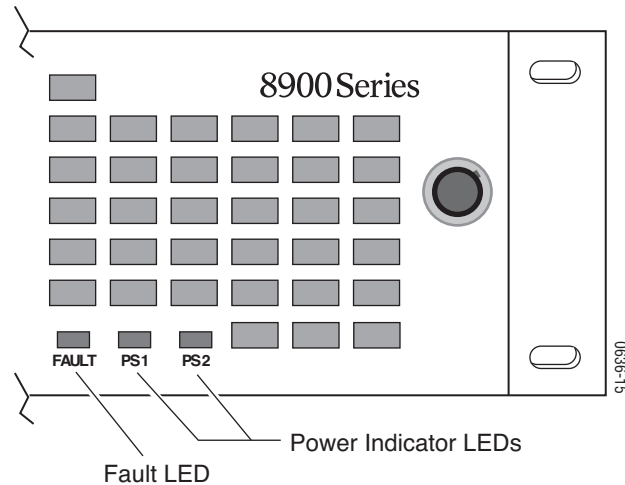

Other indicator LEDs can be viewed on the controller module (Frame Monitor or 8900NET module) with the front cover removed. Frame Monitor module indicators are discussed in [Section 4-Monitoring and Control](#). If you have a 8900NET module installed in the frame, see the *8900NET Network Interface Module Instruction Manual* for indicator details.

Monitoring and Control

Introduction

The Gecko 8900TF/8900TFN frames offer monitoring and remote control capability by providing two types of frame communication modules that can reside in the controller cell of the frame:

- Frame Monitor module (8900TF Frame), or
- 8900NET Network Interface module (8900TFN Frame).

The 8900NET Network Interface module supports all the functionality of the Frame Monitor module plus the 10 Base-T Ethernet bus for web-based GUI control and monitoring. For information on the 8900NET module and GUI refer to the *8900NET Network Interface Module Instruction Manual*.

The Frame Monitor module is described in this manual. The Frame Monitor module is an interface for the forced-air cover and Frame Alarm fault reporting.

The Frame Monitor module provides:

- Variable power to the fan front cover to regulate fan speed
- Analog module presence indication
- LED display for quick diagnostics of alarm conditions
- DIP switch for enabling and disabling alarms and the variable fan speed option

Frame Monitor Module

The Frame Monitor module comes installed in the 8900TF frame. It provides indicator LEDs on the front of the module (visible when fan front cover is removed) that report alarm conditions and module power status.

When on, the LEDs indicate:

- TEMP — Over-temperature problem
- PS2 — Power supply position 2 health problem
- PS1 — Power supply position 1 health problem
- FAN — Cooling fan is not rotating
- MOD — Module health bus error
- INHIB — Disabled module health bus
- FAULT — Reports that one or more of the above alarm conditions is present and the other Fault LEDs on the module should be checked. This LED is visible through the fan front cover Fault window.

Note When an analog module is installed, the module health alarm bus is inhibited.

The front edge of the Frame Monitor module is shown in [Figure 20](#).

Figure 20. Frame Monitor Module Front View

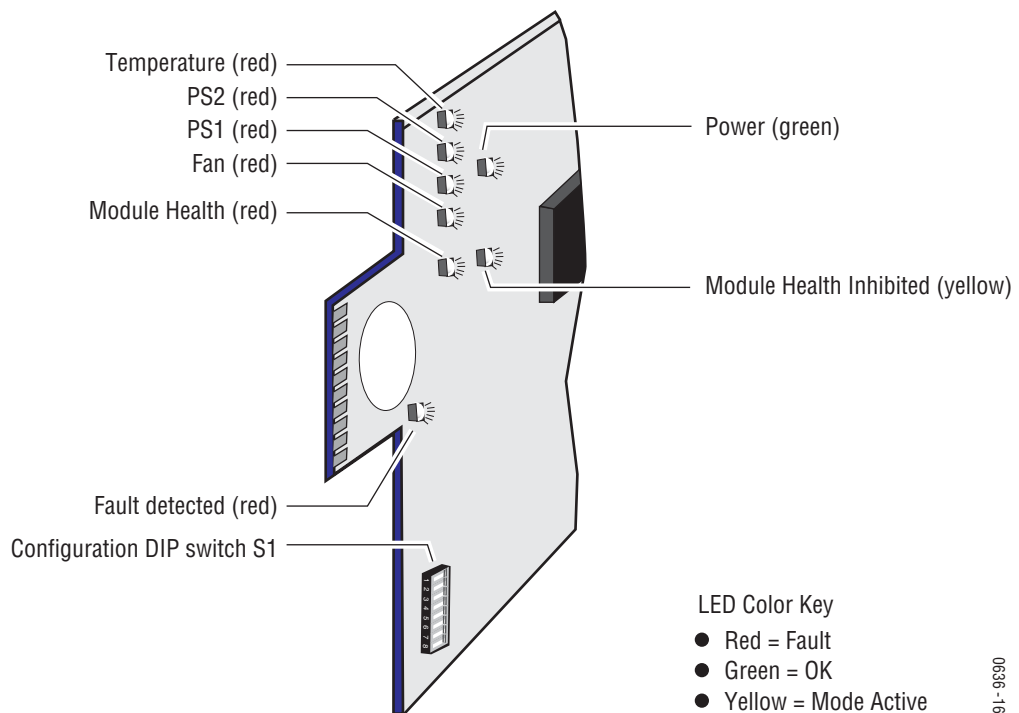

0636 -16

Enabling Alarms and Fan Speed Control Option

The Frame Monitor module has an eight position DIP switch (S1) that enables or disables the alarm functions and the variable fan speed function.

Refer to [Figure 20 on page 50](#) for the location of S1 and [Table 7](#) for the possible settings. A settings table is also silkscreened on the module.

Table 7. Configuration DIP Switch Settings

Segment	Left Position (open)	Right Position (closed)
1	PS1 Fault Reporting Enabled	PS1 Fault Reporting Disabled
2	PS2 Fault Reporting Enabled	PS2 Fault Reporting Disabled
3	Overtemp Fault Reporting Enabled	Overtemp Fault Reporting Disabled
4	Fan Fault Reporting Enabled	Fan Fault Reporting Disabled
5	Module Fault Reporting Enabled	Module Fault Reporting Disabled
6	Fan Speed Controlled by Temperature	Fan Speed Fixed at Maximum
7	Not Used	
8	Not Used	

Frame Monitor Module Indicator LEDs

The possible LED status and conditions indicated are shown in [Table 8](#).

Table 8. Indicator LEDs and Conditions Indicated

LED	LED State	Condition
Power (green)	Off	Power is off or onboard regulator has failed
	On continuously	Module is powered
PS2 (red)	Off	Normal operation or alarm disabled
	On continuously	Power supply 2 is present and reporting an alarm condition
PS1 (red)	Off	Normal operation or alarm disabled
	On continuously	Power supply 1 is present and reporting an alarm condition
FAN (red)	Off	Normal operation or alarm disabled
	On continuously	One or more fans in the front cover assembly is not rotating
MOD (red)	Off	Normal operation or alarm disabled
	On continuously	Module health bus is not disabled and one or more modules is reporting an internal fault
	Flashing	One or more modules is reporting a data error
INHIB (yellow)	Off	Normal operation or alarm disabled
	On continuously	A non-compliant module in the frame has disabled the module health bus
FAULT (red)	Off	Normal operation
	On continuously	One or more of the onboard fault LEDs is illuminated or flashing

Specifications

Introduction

This section discusses specifications for the Gecko 8900 frames and the 8900PSX 100 W power supply. Refer to the module instruction manual for the specifications for a particular audio/video module.

Frame Specifications

See [Table 9](#) for a list of the 8900 Series frame specifications. Specifications are subject to change without prior notice.

Table 9. 8900 Series Frame Specifications

Parameter	Value
Module Cells	
Input Type	75 Ω loop through BNCs (shield-isolated from ground)
Termination (Serial Digital)	CONARE BCP-TA (or equivalent, customer-supplied)
Output Type	Eight 75 Ω BNCs
Frame Fault Reporting	
Connector Type	DB-9F pins 8 and 9 of RS-232 connector
Maximum Current — Alarm OFF	100 μ A when voltage < 24 V is applied
Maximum Voltage — Alarm ON	2 V with current < 20 mA
Maximum allowable voltage — center conductor to shield	24 V
Maximum allowable current	20 mA
Front Panel Indicators	
PS 1 & PS 2	Green LED — ON indicates operating correctly
Fault (TF/TFN front covers only)	Red LED — ON indicates an error or failure

Table 9. 8900 Series Frame Specifications - (continued)

Parameter	Value
Operating Conditions	
Input voltage range	100 V to 240 VAC, 47 Hz to 63 Hz
Maximum input current	1.5 A
Operating temperature range	0 to 45 degrees C
Non-operating temperature range	-10 to +70 degrees C
Humidity	Up to 95% non-condensing
Mechanical	
Height	2 RU, 3.5 inches (89 mm)
Width	19 inches (483 mm)
Depth	13.25 inches (337 mm)
Weight with no modules, 1 power supply	TX frame: 18.55 lbs (8.4 kg) TF frame: 19.2 lbs (8.7 kg) TFN frame: 20.2 lbs (9.16 kg)
Weight with no modules, 2 power supplies	TX frame: 19.75 lbs (8.96 kg) TF frame: 20.4 lbs (9.2 kg) TFN frame: 21.4 lbs (9.7 kg)
Power	
Inputs	Two independent AC inputs
Connector Type	IEC with cord retention
AC voltage	100 V to 240 V, 50/60 Hz
Maximum power dissipation	TX frame: 30 W TF- and TFN frames: 100 W
Environmental	
Operating temperature	0 to 45 degrees C
Non-operating temperature	-10 to +70 degrees C
Humidity	< 90% non-condensing

Power Supply

See [Table 10](#) for a list of power supply specifications. Specifications are subject to change without prior notice.

Table 10. Power Supply Specifications

Parameter	Value
Inputs	
Voltage Range	100 V to 240 V, continuous range
Frequency	47 Hz to 63 Hz
Outputs	
Voltage/Current	+12.4 V @ 8 A and -12.4 V @ 1.5 A, common ground (total not to exceed 100 W)
Load/Line Regulation	± 3% for loads from 100 mA to 5 A + 7%, - 3% for loads from 0 to 100 mA
Current Limit	+12 V < 10 A under short circuit conditions -12 V < 7 A under short circuit conditions
Status Range (healthy)	+12 V + 8% - 4%; -12 V + 8% - 4%
Test Points	Three: +12 V, -12 V, and ground
Power Factor Correction	Complies with EN61000-3-2 Class D

Appendix – 8900 Frames Archive

Introduction

This appendix provides reference information for previously released 8900 frames. Use this archive to access a summary of cabling and configuration information for earlier versions of the 8900 frames.

Identifying Frame Types

There are a number of ways to determine what type of frame you have. [Table 11](#) lists all available frame types and how they can be identified. The assembly number of the frame is printed on a label located inside the frame on the front of the chassis.

Network Configuration Storage

One of the important differences between current and earlier version 8900 frames is the location of network configuration storage. 8900NET software version 3.0.0 and later enabled storage of the IP addresses (network configuration) on the frame backplane on frames that are equipped with storage capability. In earlier versions of software and frame types with no storage capacity, the IP addresses are stored on the 8900NET module and stay with the module when it is moved to another frame.

Table 11. 8900 Frames Types IP Storage Capability

Model Number	Backplane	Assembly Number	Network Config Storage
8900TFN-A	Audio backplane with 1 IC	610-0960-00	8900NET module
8900TFN	Video backplane with 1 IC	630-0063-00	8900NET module
8900TFN-A	Audio backplane with 2 ICs	610-0960-01	Frame backplane
8900TFN-V	Video backplane with 2 ICs	610-0984-00	Frame backplane

To determine what frame model you have and where IP addresses are stored, you may also access the Frame Status page with the web browser.

All frames with 8900NET cards with software version 3.0.0 and later will report a **Network Config** status message on the Frame Status page as one of the following:

- Network configuration stored on 8900NET module, or
- Network configuration stored on frame.

Video Frame

Earlier versions of the 8900 BNC/Video TX/TF/TFN frames have a backplane configuration as shown in [Figure 21](#). The earlier frames differ from the current frames in two main areas:

- The Frame Alarm Port on earlier modules is accessed by an external BNC connector on the backplane labeled SMPTE ALARM J101.
- There is no network configuration (IP address) storage capability on these frames.

SMPTE Alarm Connector

Use of the SMPTE Alarm bus requires the Frame Monitor or 8900NET Network Interface module be installed in the frame. For more information on the 8900NET module, see the *8900NET Network Interface Module Instruction Manual*.

The SMPTE Alarm reporting is accessed through J101 shown in [Figure 21](#).

Figure 21. 8900 Video Frame Backplane With SMPTE Alarm BNC

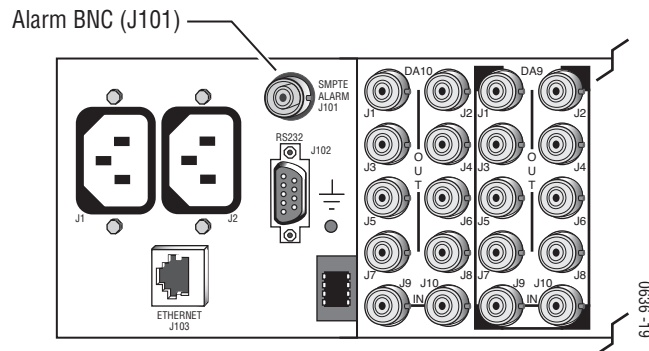

The conditions monitored by SMPTE Alarm reporting are:

- Frame Health
 - Power supply 1 voltage
 - Power supply 2 voltage
 - Fan rotation
 - Frame temperature
- Module Health (capability module dependent, refer to specific module instruction manual).
 - Power supply voltage
 - Signal present at input
 - EQ warning
- EDH Monitoring (capability module dependent, refer to specific module instruction manual).
 - EDH error detected

The impedance between the center conductor and shield of J101 can be in one of two states:

- Open – less than 100 μ A of current will flow, and
- Closed – less than 2 V will appear from center conductor to shield with less than 20 mA of current flowing.

There are three operational conditions (capability is module dependent, refer to specific module instruction manual):

- Open – no faults,
- Closed – there is an internal fault, and
- Pulsing – there has been a signal error detected in one of the modules.

In addition to fault reporting through the SMPTE Alarm connector, there is a RED Fault LED on the Frame Monitor and 8900NET Network Interface modules that is visible through the Fault window of the 8900TF/TFN front cover. This LED is OFF when no fault conditions are detected and ON when either an internal fault or a signal error is detected.

A number of frames can be coupled together as one alarm circuit by using a T-connector. Refer to [Figure 22 on page 60](#) for a typical alarm circuit interconnect diagram.

Figure 22. SMPTE Alarm Fault Reporting Connections

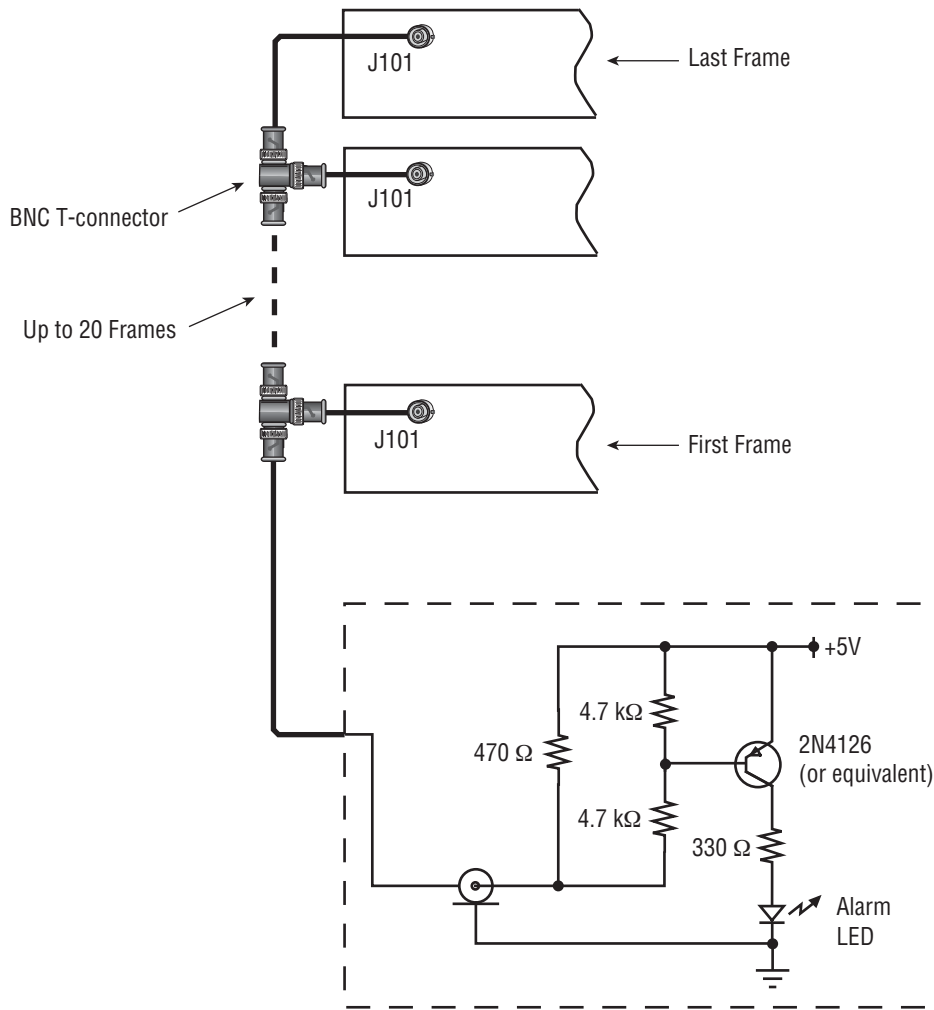

Note Refer to “SMPTE Fault Reporting in Television System” standard for further details.

Audio Frame

Earlier versions of the 8900 Audio TX/TF/TFN frames have a backplane configuration as shown in [Figure 23](#). The earlier frames differ from the current frames in one main area:

- There is no network configuration (IP address) storage capability on these frames.

The Frame Alarm connection is on pins 8 and 9 of the RS-232 connector as discussed in [Frame Alarm Connector](#) on page 41.

Figure 23. 8900 Audio Frames Backplane

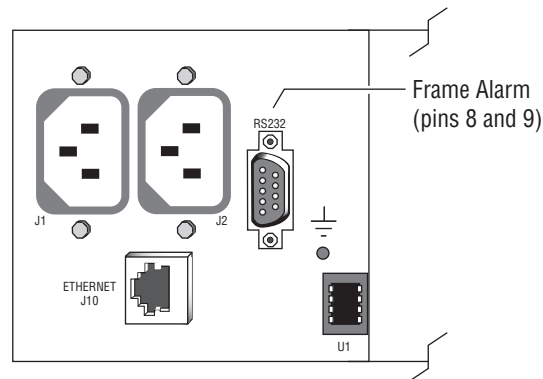

Index

Numerics

- 120V line cord [46](#)
- 240V line cord [46](#)
- 8900 models
 - FAN [26](#)
 - FN [26](#)
 - TF [26](#)
 - TFN [26](#)
 - TX [26](#)
- 8900TF frame
 - description [28](#)
 - overview [26](#)
 - upgrading [28](#)
- 8900TFN frame
 - description [28](#)
 - overview [26](#)
- 8900TX frame
 - description [27](#)
 - overview [26](#)
 - upgrading [27](#)

A

- alarms
 - conditions [42](#)
 - example [43](#)
 - Frame Alarm (RS-232 connector) [41](#)
 - SMPTE Alarm BNC [59](#)
- analog module presence [49](#)
- applying power [48](#)
- audio frames
 - earlier versions [61](#)

B

- branch circuit [46](#)

C

- communication ports [26](#)
- conditions indicated [51](#)

- connector configurations [38](#)
- controller cell [49](#)
- controller modules [36](#)
- cord retainer [47](#)

D

- direct input/output connectors [38, 39](#)
- disables [51](#)
- disabling alarms [49](#)
- documentation online [4](#)

E

- enables [51](#)
- equipment rack [35](#)
- Ethernet [49](#)
 - capability [28](#)
 - connection [30](#)

F

- FAQ database [4](#)
- Fault LED [50](#)
- features [25](#)
- Frame alarm [30](#)
- frame connections [29](#)
- Frame Monitor Module [36, 41, 49, 58](#)
- frame options [26](#)
- frame types [57](#)
 - identifying [57](#)
- frames [37](#)
- frequently asked questions [4](#)
- front covers [26](#)

G

- GeckoFlex frame
 - power supplies [37](#)
- Grass Valley web site [4](#)

I

- indicator LEDs [50](#)
- input/output configuration [36](#)
- input/output connectors [39](#)
- installation
 - power supply [37](#)
- IP Address
 - storage [57](#)

L

- line voltage [46](#)
- loop-through input [39](#)

M

- maximum power [26](#)
- module health [42, 59](#)
- module health alarm [50](#)
- Module Health Bus [42](#)
- monitoring [49](#)

N

- network configuration storage [31, 57](#)
- Network Interface Module [36, 41, 49, 58](#)

O

- online documentation [4](#)
- options [26](#)
- output connectors [38](#)
- over-temperature [50](#)

P

- power [54](#)
- power calculations [32](#)
- power cords [46](#)
- power supplies
 - installation [37](#)
- power supply cells [36](#)

R

- redundant power [46](#)
- remote control [49](#)
- retainer clip [47](#)
- RS-232 Connector [41](#)
 - impedance [43](#)

S

- SMPTE alarm [41, 58](#)
 - impedance [59](#)
- software download from web [4](#)
- specifications
 - frame [53](#)
 - power supply [55](#)

T

- termination [39](#)
- typical alarm circuit [59](#)

U

- upgrade options [26](#)

V

- variable fan speed [51](#)

W

- web site
 - documentation [4](#)
 - FAQ database [4](#)
 - Grass Valley [4](#)
 - software download [4](#)