

# VEA-1023

## Description

The VEA-1023 is an analog video distribution amplifier with 8 outputs providing differential input, clamping, automatic equalization and gain adjustments. Equalizing up to 300 m (1000') of Belden 8281 cable, the gain and equalization can be controlled from the frame control panel, the remote control system (with menu type adjustments) or automatically (using a test signal at the input). A multi-colored LED, visible with the door closed, reports the card status. The differential input provides rejection of hum and other artifacts on incoming signals. The VEA-1023 is housed in a Densité frame and a single or double width rear connector panel is required.

## Features

- Analog video differential input with passive loop-through
- Eight 75 Ω outputs
- Signal presence and 525/625 detection and reporting
- Supports NTSC and PAL video signal formats
- Handles AES-3id audio signal format
- 50 MHz analog video bandwidth
- Equalization up to 300m (1000')
- Status LED and remote reporting

## FUNCTIONAL BLOCK DIAGRAM

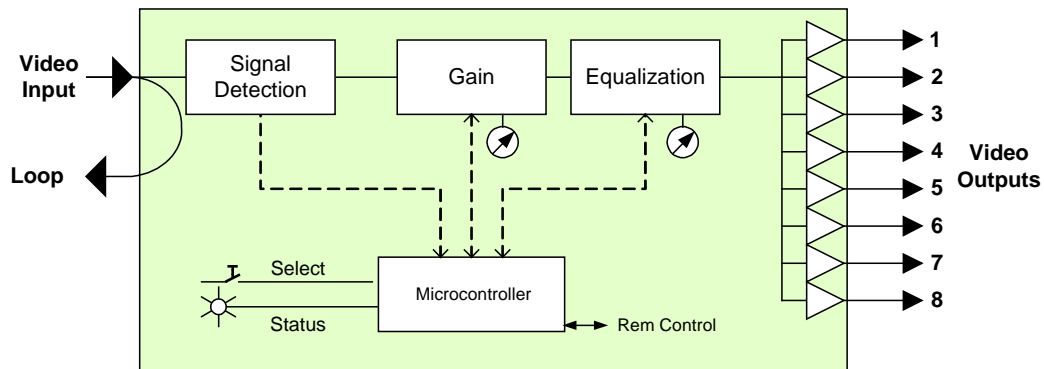

## SPECIFICATIONS

### INPUT

Video signal: ..... Any 1 Vpp nominal signal  
Return loss: ..... > 40 dB up to 5 MHz  
Coupling: ..... DC or AC with Clamping  
(Hard/Soft/None)  
Level: ..... 0.3 to 1.5 Vpp  
Impedance: ..... 75 Ω bridging  
Max. Common mode signal: ..... 28 Vpp  
Common mode rejection: ..... > 65 dB to 10 kHz

### OUTPUTS (8)

Video signal: ..... 1 Vpp nominal, adjustable  
Return loss: ..... > 50 dB up to 10 MHz  
Impedance: ..... 75 Ω  
Phase match between outputs: ..... < 0.1° @ 4.43 MHz  
Output isolation signal: ..... > 40 dB @ 10 MHz  
Response variation (1-8 loads): < 0.1 dB, 20 MHz

## PROCESSING PERFORMANCE

Gain range: ± 3 dB  
Freq. response: <±0.02dB up to 5MHz,  
±0.05dB up to 10MHz  
EQ range: 0-300 m Belden 8281,  
0-200 m Nokia 0.6/2.8  
EQ response: <±0.05dB up to 5MHz,  
±0.15dB up to 10MHz,  
Diff. gain: < 0.15%  
Diff. phase: < 0.15° (8 loads),  
< 0.1°, (2 loads)  
Horizontal tilt: < 0.25%, DC coupling  
Vertical tilt: < 0.25%, DC coupling  
Signal to noise ratio: > 70 dB rms/0.714V, flat 15 MHz  
Chroma/luma delay error: < ±1 ns  
Chroma/luma gain error: < ±0.02 dB  
Hum: < 1 mV  
Processing delay: 15 ns  
Power: single 2 W, dual 2.5 W

# VEA-1023 Analog Video Auto Equalizing DA Guide to Installation and Operation

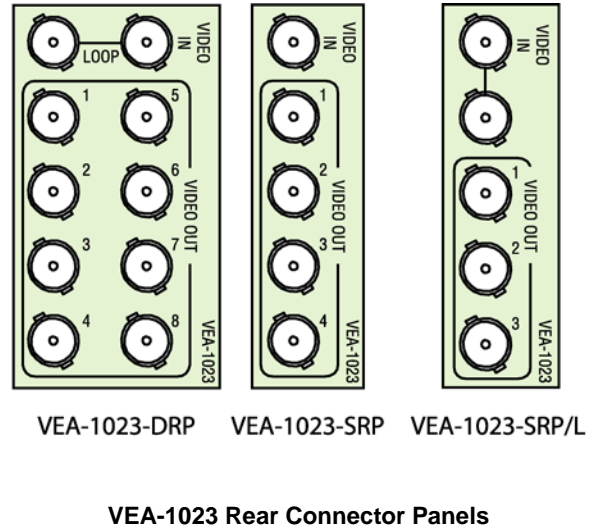
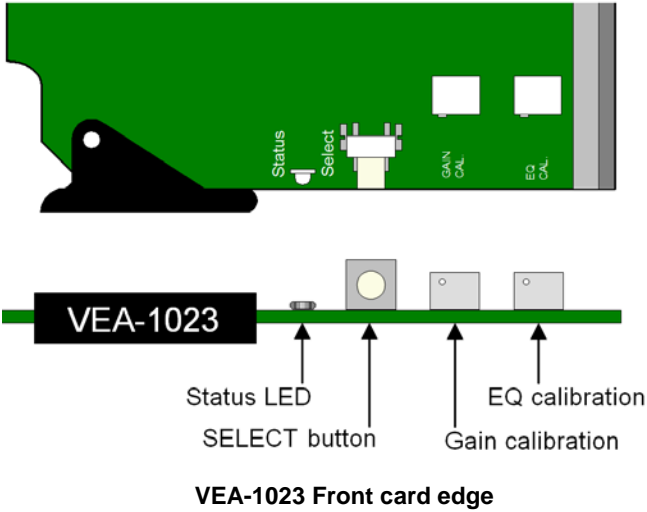

## INSTALLATION

Make sure the following items have been shipped with your VEA-1023. If any of the following items are missing, contact your distributor or Grass Valley.

- \* VEA-1023 Analog Audio Auto Equalizing DA
- \* VEA-1023-DRP, VEA-1023-SRP or VEA-1023-SRP/L rear panel

The VEA-1023 and its associated rear connector panel must be mounted in a DENSITÉ frame. It is not necessary to switch off the frame's power when installing or removing the VEA-1023. See the DENSITÉ Frame manual for detailed instructions for installing cards and their associated rear panels.

The VEA-1023 has multiple inputs and outputs, and making space for all the necessary connectors at the rear of the frame requires a double-width rear panel.

When a double-width rear panel has been installed, the VEA-1023 must be installed in the right-most of the two slots covered by the panel in order to mate with the panel's connectors. If it is placed in the wrong slot, the front panel LED will flash red. Move the card to other slot for correct operation. No damage will result to the card should this occur.

It is also possible to use the VEA-1023 with a single-width rear panel if fewer outputs are required. This will free up slots in the Densité frame. Choose the SRP rear panel to get 4 outputs but no loop-through, or the SRP/L panel to get three outputs plus the loop-through.

## Overview

The DENSITÉ frame incorporates a central controller card, located in the center of the frame, which is equipped with an LCD display and a control panel. The controller handles error reporting and local and remote control for all cards installed in the frame. The display and control panel are assigned to the card in the frame whose SELECT button has been pushed.

### Status Monitor LED

The status monitor LED is located on the front card-edge of the VEA-1023 module, and is visible through the front access door of the DENSITÉ frame. This multi-color LED indicates module status by color, and by flashing/steady illumination, according to the following chart (which also indicates fault reporting for this card on the DENSITÉ frame's serial and GPI interfaces).

	REPORT		COLOR (F=flashing)			
	N.R.M.*	GPI	G	Y	R	FR
No errors			⊕			
No signal In	⊕				⊕	
Auto Calibrate	⊕			⊕		

⊕ : Factory default.     User configurable

\* = Non-Requested Messages

A "Flashing Yellow" Status LED indicates that the SELECT button on the front panel has been pushed, and the controller display and control panel are now assigned to this card.

The LED color assignments for some error conditions can be reconfigured by the user (see the menu for details).

### User Interface

Pushing the SELECT button will cause the on-card STATUS LED to flash yellow, and the card identification

# VEA-1023 Analog Video Auto Equalizing DA Guide to Installation and Operation

and the current status will be shown on the controller card's display. The STATUS LED will revert to its normal state upon a second push of the button, or after a short delay. The messages which may appear are shown in the top line of the menu chart below.

**Example :**

V	E	A	-	1	0	2	3								
N	O	S	I	G	N	A	L								

Use the local control panel to access the detailed status report shown in the STATUS menu on page 3.

**Operating Parameter Adjustment**

The VEA-1023 has operating parameters which may be adjusted at the controller card interface. After pressing the SELECT button on the VEA-1023 card, use the keys on the local control panel (described in the Controller card manual) to step through the displayed menu and adjust the parameters. The menus are shown below.

**VEA-1023 Menus**

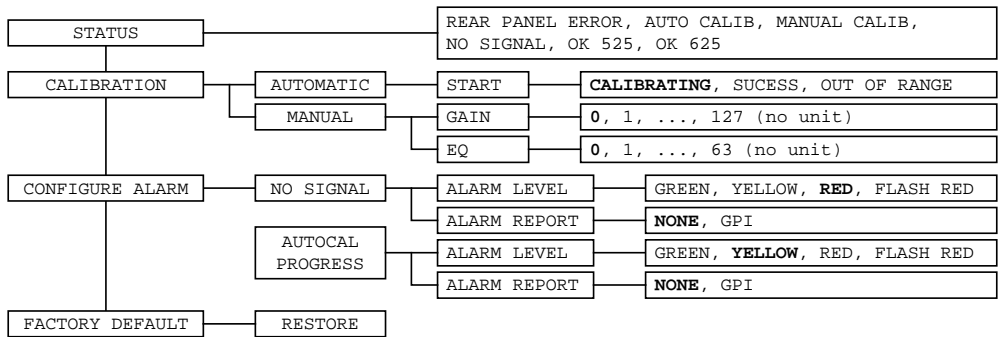

**USER PRESET menu**

Displays status of the different board alarms. The higher-level alarm is displayed, even if not configured to activate the STATUS led.

**REAR PANEL ERROR** Indicates an absence of the rear panel or an incompatibility between the module and the rear panel. The STATUS led turns on flashing red.

**AUTO CALIB** Indicates automatic calibration is set, jumper LK2 position 3-4.

**MANUAL CALIB** Indicates manual calibration is set, jumper LK2 position 1-2.

**OK 525** Indicates a valid 525-line incoming signal

**OK 625** Indicates a valid 625-line incoming signal

**NO SIGNAL** Indicates an absence of input signal

**CALIBRATION menu**

Enables the automatic or manual Gain/Equalization calibration

**AUTOMATIC** Enables automatic calibration

**START** Press [SELECT] to activate automatic calibration. **CALIBRATING** is displayed, the last character appears as a

rotating dash |, /, —, \. Calibration starts, **SUCCESS** is displayed in case of success and **OUT OF RANGE** in case of failure. Press [ESC] to exit the menu without saving.

**MANUAL**

Enables manual calibration

**GAIN**

Gain can be set within a range of 0 to 127. These values have no units. 0 is the default value.

**EQ**

Equalization can be set within a range of 0 to 63. These values have no units. 0 is the default value.

**CONFIGURE ALARM menu**

Set the Level (STATUS LED color) and/or Report (GPI relay activation) that will occur when the ADC-1721 detects the listed error:

- NO SIGNAL
- AUTOCAL PROGRESS

Note: Alarm relay activation can only occur if the parameter GPI REPORT is enabled in the menu of the Densité frame's controller card

**ALARM LEVEL**

Associates a STATUS LED color (GREEN, YELLOW, RED or FLASH RED) with each error.

# VEA-1023 Analog Video Auto Equalizing DA Guide to Installation and Operation

This selection has no influence on the {STATUS} menu display.

**ALARM REPORT** Select *GPI* to activate an alarm relay when an error is detected (but see note above) The default value is NONE.

## FACTORY DEFAULT menu

Select *RESTORE* to reset all of the menu-adjustable parameters to a factory-preset state (indicated in the menu by **Bold type** in the list of available choices).

## CALIBRATION

### First-time calibration

To ensure proper operation of the VEA-1023's auto-calibration feature, a one-time calibration procedure must be done. This calibration sets the card to unity gain and equalisation. Make sure that all VEA-1023 outputs are correctly terminated.

#### NEEDED:

- Signal generator: full-field colour bars with 100% luma, 75% chroma;
- Accurate measuring equipment for luma and chroma levels;
- Small flat head screwdriver for potentiometer adjustment.

**IMPORTANT:** The cable between the signal generator and the VEA-1023 must have a length of nearly 100 m. The First-time Calibration adjusts the performance of the card for short cable lengths.

The location of jumpers and trim pots mentioned in these procedures is shown in this diagram:

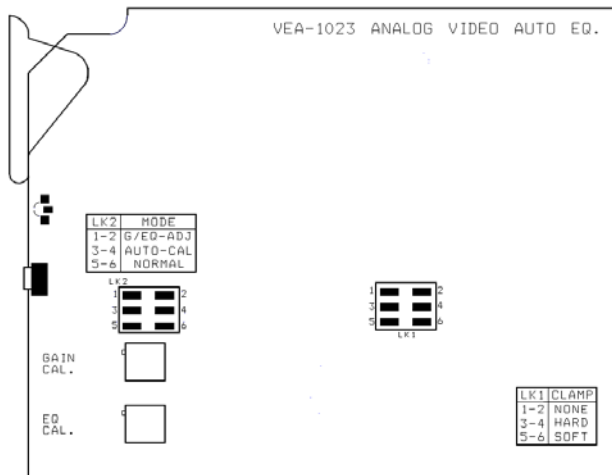

### 1. 100% luma level adjustment

- Connect the 100/75 colour bars signal to the VEA-1023's input connector situated at the back of the DENSITÉ frame, through the 100 m cable.
- Connect an output to the measuring equipment.
- Before inserting the VEA-1023 into its slot, place a jumper over pins 1-2 "G/EQ ADJ" of header LK2.

- Insert card. Wait approximately 10 seconds for the output to stabilize to the current gain and EQ adjustments.

The LED is yellow.

Using the measuring equipment to observe the result, slowly turn the "GAIN CAL" potentiometer (P3) situated on the card edge to adjust the white level to 100%.

Format	100% white level
NTSC with setup	714 mV or 100 IRE
NTSC no setup	714 mV or 100 IRE
PAL	700 mV

**NOTE:** The output reacts slowly when the potentiometer is turned and it is constantly fluctuating even when the potentiometer is not being turned. This is normal. The card is continually comparing the input signal to the potentiometer value.

### 2. Equalisation adjustment

- Keep the card in the slot.
- Using the measuring equipment to observe the result, slowly turn the 'EQ CAL' potentiometer to adjust the peak-to-peak level of the red bar in the 100/75 colour bars signal at the output of the VEA-1023.

Another method is to use a vectorscope and make all colour vectors converge upon the center of their respective tight tolerance boxes.

Format	75% p-p red level
NTSC with setup	626 mV or 87.7 IRE
NTSC no setup	677 mV or 94.9 IRE
PAL	664 mV

**NOTE:** Again, the output reacts slowly when the potentiometer is turned and it is constantly fluctuating even when the potentiometer is not being turned. This is normal. The card is continually comparing the input signal to the potentiometer value.

When the desired result is attained, remove the VEA-1023 from the slot. **The following auto-calibration is necessary to save these gain and EQ adjustments.**

### Auto-calibration

This calibration adapts the VEA-1023 to the system. Send the full-field 100/75 colour bars signal through the system to correct the attenuation caused by cable length.

After removing the VEA-1023 from the slot, there are three ways to perform an auto-calibration. First, remove the jumper over pins 1-2 of LK2. Then,

# VEA-1023 Analog Video Auto Equalizing DA Guide to Installation and Operation

**Without (DENSITÉ) controller:** place the jumper over pins 3-4 "AUTO-CAL" of LK2. Insert the card. The LED is yellow. The calibration starts after 2 s, wait approximately 20 seconds for the LED to return green.

Remove the card and place the jumper over pins 5-6 "NORMAL" of LK2 and insert the card.

**With (DENSITÉ) controller:** place the jumper over pins 5-6 "NORMAL" of LK2. Insert the card. Wait for the LED to become green. Enter the VEA-1023's menu by pressing the Select button on the card edge. With the chassis controller, from "STATUS" press [-], from "CALIBRATION" press [SELECT], from "AUTOCALIBRATION" press [SELECT], from "START" press [SELECT], then "AUTOCALIBRATING" will appear. The auto-calibration ends with either "SUCCESS" or "OUT OF RANGE". If out of range, there is no input signal or the correction needed is out of the VEA-1023's range. Check the input signal.

**With iControl:** Select auto-calibration and wait for the result. If the result is "OUT OF RANGE", there is no input signal or the correction needed is out of the VEA-1023's range. Check the input signal.

The VEA-1023 is now calibrated and ready for use.

*NOTE: The "GAIN ADJ" and "EQ ADJ" potentiometers are used to set the reference gain and equalization levels. These levels are used during the auto-calibration process. Hence, turning the potentiometers while in normal mode (jumper on pins 5-6 "NORMAL" of LK2) will have no immediate effect. The effect will be seen only after the next auto-calibration. If this happens, the First-time Calibration and Auto-calibration procedures described above must be redone.*

*NOTE: if you push on the Select button during the calibration, until the led returns green, the final value will replace the factory default value. According to the video input signal, NTSC or PAL, the card will store two different factory default values: one for NTSC and one for PAL.*

## Clamp Settings

The degree of clamping applied to the input signal can be adjusted using the jumper LK1 (see the figure on page 4 for its location)

<u>Jumper position</u>	<u>Degree of clamping</u>
1 – 2	None
3 – 4	Hard
5 – 6	Soft

## COMPLIANCE

### Radio Frequency Interference and Immunity

This unit generates, uses, and can radiate radio frequency energy. If the unit is not properly installed and used in accordance with this guide, it may cause interference with radio communications. Operation with non-certified peripheral devices is likely to result in interference with radio and television reception. This equipment has been tested and complies with the limits in accordance with the specifications in:

FCC Part 15, Subpart B; CE EN50081-1:1992; CE EN50082-1:1992.

### Grass Valley Technical Support

For technical assistance, contact our international support center, at:  
1-800-547-8949 (US and Canada) or +1 530 478 4148.

To obtain a local phone number for the support center nearest you, please consult the *Contact Us* section of Grass Valley's website ([www.grassvalley.com](http://www.grassvalley.com)).

An online form for e-mail contact is also available from the website.

### Corporate Head Office

Grass Valley  
3499 Douglas-B.-Floreani  
St-Laurent, Quebec H4S 2C6  
Canada

Telephone: +1 514 333 1772  
Fax: +1 514 333 9828  
[www.grassvalley.com](http://www.grassvalley.com)