

DENSITÉ series

HDA-1911/1931 Single/Dual 3Gbps HD-SDI Distribution Amplifiers Guide to Installation and Operation

M873-9900-102

14 Mar 2011



Miranda

Technologies Inc.

3499 Douglas-B.-Floreani

St-Laurent, Québec, Canada H4S 2C6

Tel. 514-333-1772

Fax. 514-333-9828

www.miranda.com

© 2011 Miranda Technologies Inc.

Electromagnetic Compatibility



This equipment has been tested for verification of compliance with FCC Part 15, Subpart B requirements for Class A digital devices.

NOTE: This equipment has been tested and found to comply with the limits for a Class A digital device, pursuant to part 15 of the FCC Rules. These limits are designed to provide reasonable protection against harmful interference when the equipment is operated in a commercial environment. This equipment generates, uses, and can radiate radio frequency energy and, if not installed and used in accordance with the instruction manual, may cause harmful interference to radio communications. Operation of this equipment in a residential area is likely to cause harmful interference in which case the user will be required to correct the interference at his own expense.



This equipment has been tested and found to comply with the requirements of the EMC directive 2004/108/CE:

- EN 55022 Class A radiated and conducted emissions
- EN 55024 Immunity of Information Technology Equipment
- EN 61000-3-2 Harmonic current injection
- EN 61000-3-3 Limitation of voltage changes, voltage fluctuations and flicker
- EN 61000-4-2 Electrostatic discharge immunity
- EN 61000-4-5 Surge immunity
- EN 61000-4-11 Voltage dips, short interruptions and voltage variations immunity

How to contact us:

For technical assistance, please contact the Miranda Technical support centre nearest you:

Americas

Telephone:

+1-800-224-7882

e-mail:

techsupp@miranda.com

Asia

Telephone:

+852-2539-6987

e-mail:

asiatech@miranda.com

Europe, Middle East, Africa, UK

Telephone:

+44 (0) 1491 820222

e-mail:

eurotech@miranda.com

China

Telephone:

+86-10-5873-1814

e-mail:

asiatech@miranda.com

France (only)

Telephone:

+33 (0) 1 55 86 87 88

e-mail:

eurotech@miranda.com

Visit our web site at www.miranda.com

Table of Contents

1	HDA Single/Dual 3 Gbps HD-SDI Distribution Amplifiers	1
1.1	Introduction	1
1.2	Features	1
1.3	Block Diagrams	1
1.4	Front Card-edge Interface.....	2
2	Installation	3
2.1	Installation of Rear Connector Panels	3
2.2	Card Installation	4
2.3	Installing Densité-2 Cards and Rear Modules in a Densité-3 Frame	4
2.4	Signal Connections on Rear Connector Panels	6
2.5	Rear Panel Configurations	7
3	Operation	10
3.1	Control Options	10
3.2	Card-Edge Status LED	10
3.3	Local control using the Densité frame control panel.....	11
3.3.1	Overview	11
3.3.2	Menu for local control.....	11
3.4	Remote control using iControl.....	12
3.4.1	The iControl graphic interface window.....	12
3.4.2	The <i>Input</i> panel	14
3.4.3	The <i>Rear</i> panel	15
3.4.4	The <i>Status</i> panel.....	15
3.4.5	The <i>Output</i> panel	16
3.4.6	The <i>Alarms</i> panel.....	16
3.4.7	The <i>Info</i> panel	19
3.4.8	The <i>Presets</i> panel.....	20
4	Specifications.....	21
	ANNEX 1 – HDA-1911/1931 Local User Interface	22
	ANNEX 2 – Installing the Optical Interface	24

GUIDE TO INSTALLATION AND OPERATION

1 HDA Single/Dual 3 Gbps HD-SDI Distribution Amplifiers

1.1 Introduction

The HDA-1911/1931 is a 3Gbps HD-SDI video DA supporting a variety of compressed and uncompressed serial digital video signals. The HDA-1911/1931 provides 9 reclocked outputs with automatic equalization for up to 140 meters of cable (Belden 1694A) at 1.485 Gbps and up to 90 meters at 2.97 Gbps. The HDA-1931 also offers the added benefit of implementing a dual 1x4 amplifier instead of a single 1x9.

When longer cable lengths are required, the HDA-1911/1931 are ideal since they can natively offer fiber connectivity.

Additional protection for critical applications is provided by an optional protection bypass relay available on selected rears.

The HDA-1911/1931 will also support DVB-ASI on selected outputs.

1.2 Features

- One or two inputs
- Up to 9 3Gbps HD-SDI outputs
- Supports bit-rates all the way up to 2.97 Gbps
- Maximum flexibility offered by three operation modes: single 1x9, single 1x4, and dual 1x4 (HDA-1931) within Densite-2
- Automatic format detection and cable equalization
- Optional fiber I/O
- Optional bypass relay protection
- DVB-ASI format is also supported (not on all outputs – see rear panel drawings in Fig. 2.1 for details)
- MSB support

1.3 Block Diagrams

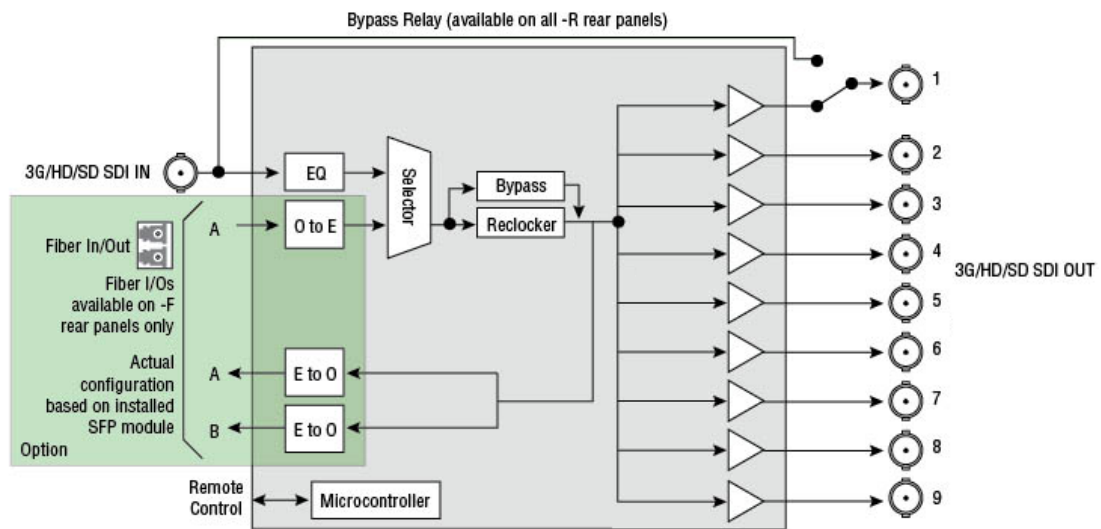

Figure 1.1(a) HDA-1911 Functional Block Diagram

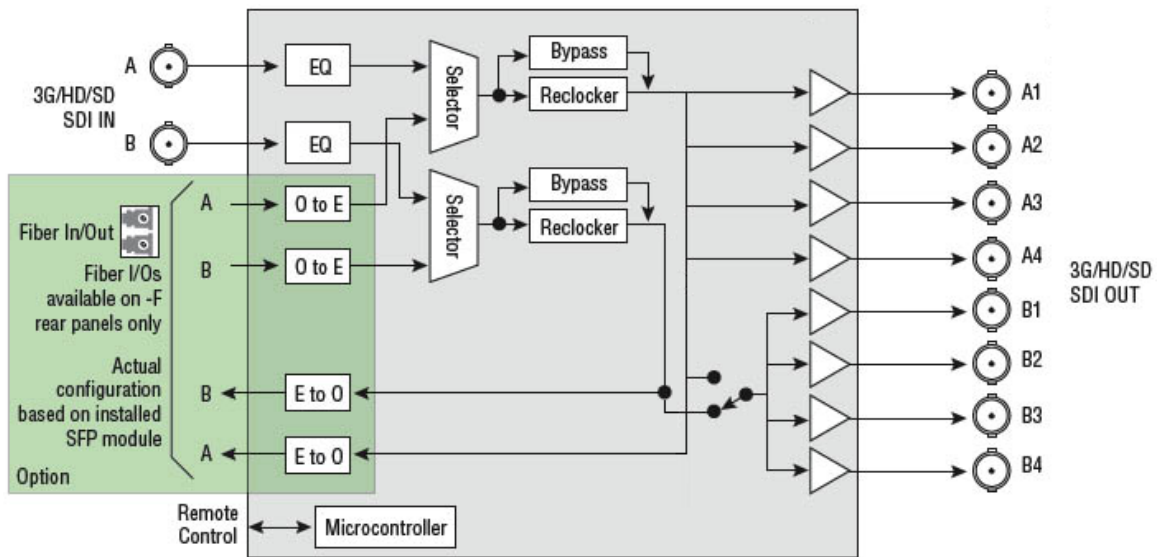

Figure 1.1(b) HDA-1931 Functional Block Diagram

1.4 Front Card-edge Interface

The front card-edge of the HDA-19x1 incorporates two elements:

- Status LED (see section 3.2)
- Select Button (see section 3.3)

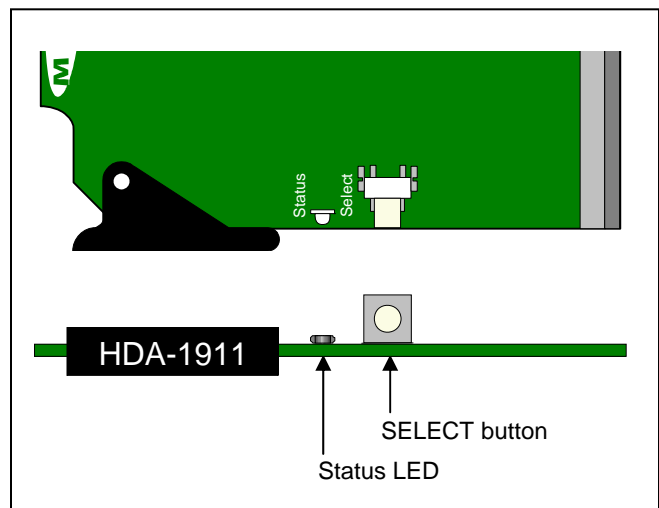

Figure 1.2 Front card-edge layout

2 Installation

2.1 Installation of Rear Connector Panels

Miranda Densité-series cards are each associated with a rear connector panel, which must be installed in the Densité frame before the card can be inserted.

The HDA-19x1 card is sized to fit into Miranda's Densité-2 frame. Eight different rear connector panels are available to fit the Densité 2 frame:

- HDA-19NN-SRP Single rear for 1x4 operating mode.
- HDA-19NN-SRP-R Single rear for 1x4 operating mode with bypass protection relay.
- HDA-19NN-SRP-F Single rear for 1x2 operating mode with fiber option support.
- HDA-19NN-DRP Double rear for 1x9 operating mode.
- HDA-19NN-DRP-R Double rear for 1x9 operating mode with bypass protection relay.
- HDA-19NN-DRP-F Double rear for 1x8 operating mode with fiber option support.
- HDA-193N-DRP Double rear for dual 1x4 operating mode (HDA-1931 only).
- HDA-193N-DRP-F Double rear for dual 1x3 operating mode with fiber option support (HDA-1931 only).

With the use of an available adapter (Densité 3 – EXT B), the HDA-19x1 can also be installed in a Densité-3 frame (see section 2.3 below). Two rear connector panels for this frame are available for the HDA-19x1:

- HDA-191N-3SRP Single rear for 1x7 operating mode.
- HDA-193N-3SRP Single rear for dual 1x3 operating mode (HDA-1931 only).

The eight Densité-2 rear panels can also be used in a Densité-3 frame, with the addition of available adapters:

- HDA-19NN-SRP + DENSITE-SRP-3RU Single rear for 1x4 operating mode.
- HDA-19NN-SRP-R + DENSITE-SRP-3RU Single rear for 1x4 operating mode with bypass protection relay.
- HDA-19NN-SRP-F + DENSITE-SRP-3RU Single rear for 1x2 operating mode with fiber option support.
- HDA-19NN-DRP + DENSITE-DRP-3RU Double rear for 1x9 operating mode.
- HDA-19NN-DRP-R + DENSITE-DRP-3RU Double rear for 1x9 operating mode with bypass protection relay.
- HDA-19NN-DRP-F + DENSITE-DRP-3RU Double rear for 1x8 operating mode with fiber option support.
- HDA-193N-DRP + DENSITE-DRP-3RU Double rear for dual 1x4 operating mode (HDA-1931 only).
- HDA-193N-DRP-F + DENSITE-DRP-3RU Double rear for dual 1x3 operating mode with fiber option support (HDA-1931 only).

All cards and rear panels can be installed with the frame power on. The card has connectors which plug into a mid-frame mother board for distribution of power and for connection to the controller card, and a second connector which plugs directly into the rear connector panel for input and output.

The rear connector panel must be installed with the card out of the frame.

- To remove an existing card from the slot, tilt up the swivel handle on the front of the card to lever the connectors apart, then use the handle to pull the card straight out of the slot.

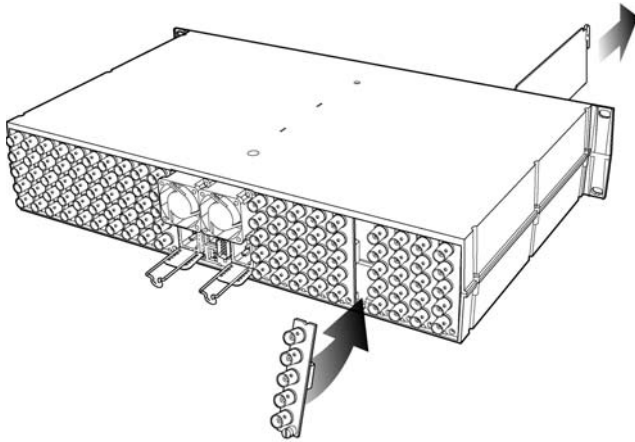

Densité-2 frame – rear panel installation

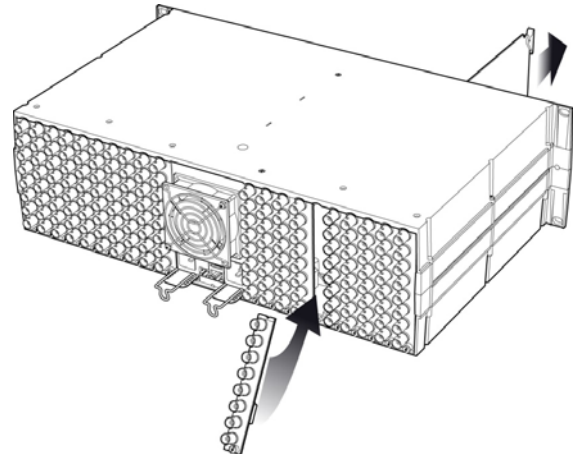

Densité-3 frame – rear panel installation

To install the connector panel:

(NOTE - if you are installing a Densité-2 rear panel plus adapter in a Densité-3 frame, please go to section 2.3)

1. If a card is installed in the slot whose rear panel is being changed, remove it as described above.
2. Remove the existing panel (either blank or belonging to an existing card that is being changed) by releasing the captive screw(s) at the bottom.
3. Position the new panel and secure it in place with the captive screw(s) at the bottom.

2.2 Card Installation

Once a matching rear connector panel has been installed, install the HDA-19x1 card as follows:

1. Open the front panel of the frame.
2. Slide the HDA-19x1 card into the slot and push gently on the handle to seat the connectors.

If the card is used with a double-width rear panel (DRP), it should be inserted into the right-hand slot. Inserting the card into the wrong slot will not damage the card, and will be flagged by the on-card status LED flashing red to indicate that there is no connection to the rear panel.

3. Close the front panel of the frame.

2.3 Installing Densité-2 Cards and Rear Modules in a Densité-3 Frame

The Densité-3 frame supports many Miranda Densité-2 series cards, including the HDA-19x1. Should you wish to install the HDA-19x1 card in your Densité-3 frame, you will need an adapter for the card. You may use one of the two 3 RU rear panels that are available for the HDA-19x1 (3SRP), or you may use one of the eight 2 RU rear panels. In

the latter case, an adapter will also be required for the rear panel, as described above. These adapters extend the height of the Densité-2 devices so that they will fit into the slots of the 3 RU Densité-3 frame.

Card adapters:

There are 3 different types of adapters available, depending on the Densité 2 card geometry, so be sure to order the adapter designed to fit the HDA-19x1 card.

Densité 3 – EXT B

Install the adapter on the HDA-19x1 as follows:

1. Fit the top edge of the card into the holding slot along the bottom edge of the adapter.
2. Align the holes in the top of the card with the holes on the adapter, and secure them together with the two provided screws and lock washers, as shown in the figure.

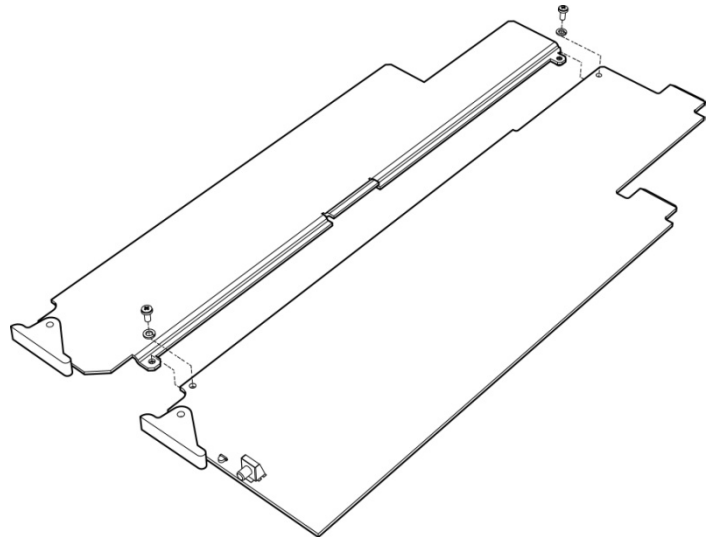

Rear adapters:

3-RU rear module adapters are available for Densité-2 rear panels:

- o DENSITE-SRP-3RU for single-slot-width rear panels
- o DENSITE-DRP-3RU for double-slot-width rear panels

Install these as follows:

1. Position the adapter at the top of the empty slot(s) on the rear of the frame.
2. Use the captive screw in the adapter to fasten it securely in position.

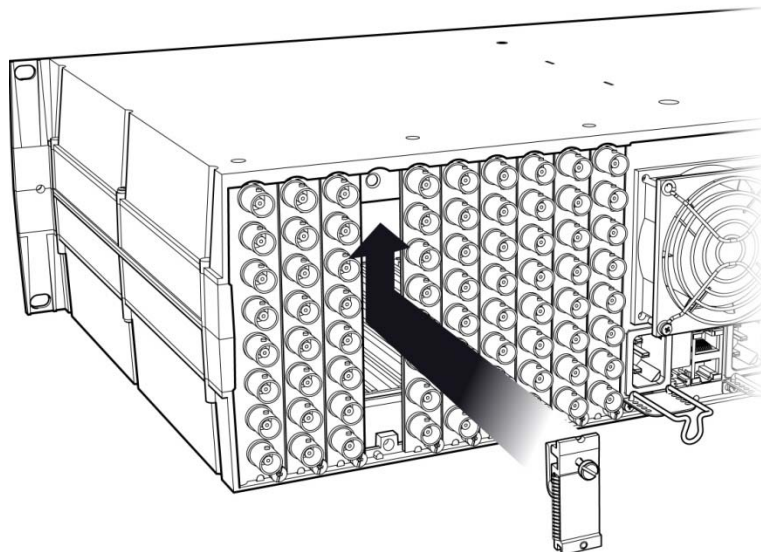

3. Slip the top of the 2RU rear panel into the slot at the bottom of the adapter, and secure it to the frame using the captive screw at the bottom of the panel.

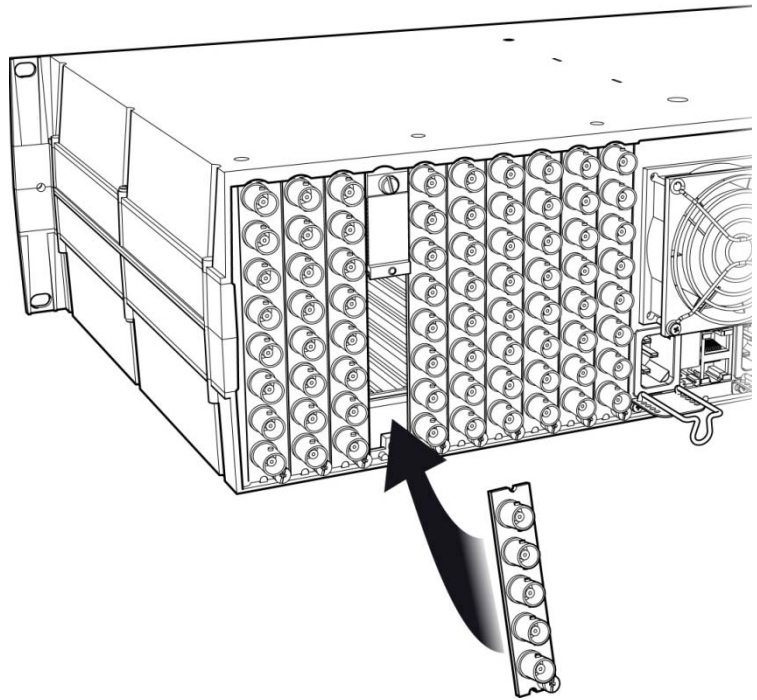

2.4 Signal Connections on Rear Connector Panels

Ten rear panels are available for the HDA-19x1. Panels are available for the Densité 2RU frame, and also for the Densité 3RU frame. The 3RU versions are identified by the number 3 in the size designator portion of the part number, e.g.

- HDA-19x1-SRP is a 2RU version
- HDA-19x1-3SRP is a 3RU version

The panel layouts and connectors are illustrated in section 2.5.

The connectors and signal types are the same for all rear types, and are as follows:

HD SDI IN – serial digital HD/SD input

Connect a serial digital video signal, conforming to the SMPTE 292M standard for HD input signals or SMPTE 259M standard for SD input signals, to the BNC labeled **HD SDI IN**. DVB-ASI is also supported. The HDA-19x1 will automatically switch to the detected video line format.

HD SDI OUT – serial digital video outputs

The HDA-19x1 provides multiple HD/SD SDI video outputs on BNC connectors, labeled **HD SDI OUT 1, 2**, etc. The SDI video signal conforms to the SMPTE 292M and SMPTE 259M-C standard. Not all outputs support DVB-ASI – see the note on page 9.

Fiber I/O connector

SFP optical modules are small, hot-pluggable cartridges which provide fiber connectivity to the HDA-1911/1931 distribution amplifiers. By using fiber instead of coaxial cable, these interfaces can be used over much longer distances without impacting signal quality.

SFP Modules can be installed into HDA-1911/1931 rear panels that offer SFP video connectivity, easily identifiable by an -F extension in the Miranda Rear part number. A single SFP optical module offers either 1 or 2 fiber connections, available as single Tx or Rx, dual Rx or Tx or as a bidirectional Rx/Tx. Dual Rx or Dual Tx on single fiber can be achieved with the WDM SFP modules.

The fiber I/O connector accepts any of the available SFP cartridges. At the time of publication of this document, the following cartridges were available:

- SFP-R-LC Single fiber Rx (input) cartridge with LC/PC connector
- SFP-RR-LC Dual fiber Rx (input) cartridge with LC/PC connector
- SFP-T-S13-LC Single fiber Tx (output) cartridge at 1310 nm with LC/PC connector
- SFP-TT-S13S13-LC Dual fiber Tx (output) cartridge at 1310 nm with LC/PC connector
- SFP-RT-S13-LC Dual fiber Rx/Tx (input/output) cartridge at 1310 nm with LC/PC connector
- SFP-RR-W-LC Single fiber dual Rx (2 inputs) cartridge with WDM - LC/PC connector
- SFP-TT-W13W15-LC Single fiber dual Tx (2 outputs) cartridge at 1310 and 1550 nm with WDM - LC/PC
- SFP-TT-CxxCyy-LC Dual optical CWDM Tx cartridge, xx/yy nm with LC/PC connector
- SFP-THTH-CxxCyy-LC Dual optical hi-power CWDM Tx cartridge, xx/yy nm with LC/PC connector

Note – for CWDM cartridges, xx and yy are the wavelengths of the two lasers.

Insert the appropriate cartridge for your application into the Fiber I/O connector, and then connect the fibers to the cartridge via the LC connectors.

- See **ANNEX 2 on page 24 for a detailed description of the installation & removal procedure.**

2.5 Rear Panel Configurations

The following diagrams illustrate the layout and connectors on the available HDA-19x1 rear panels. Note that the HDA-19x1's functionality is determined by the rear panel that is installed

- **HDA-19NN-SRP** Single rear for 1x4 operating mode.

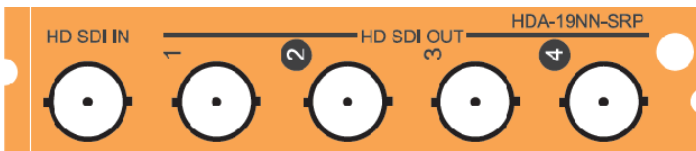

- **HDA-19NN-SRP-R** Single rear for 1x4 operating mode with bypass protection relay.



- **HDA-19NN-SRP-F** Single rear for 1x2 operating mode with fiber option support.

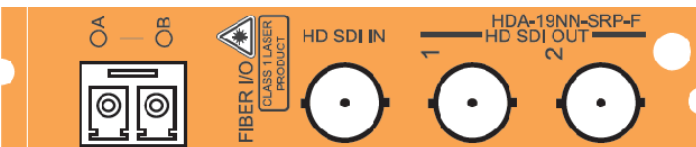

- **HDA-19NN-DRP** Double rear for 1x9 operating mode.

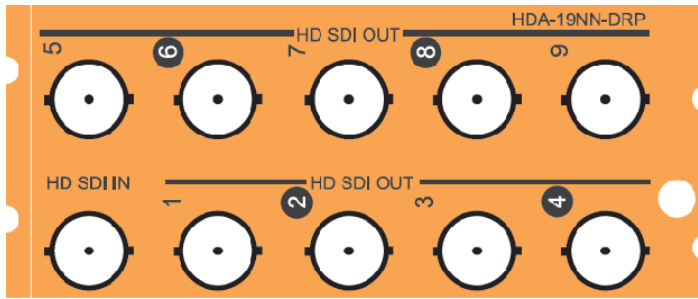

- **HDA-19NN-DRP-R** Double rear for 1x9 operating mode with bypass protection relay.

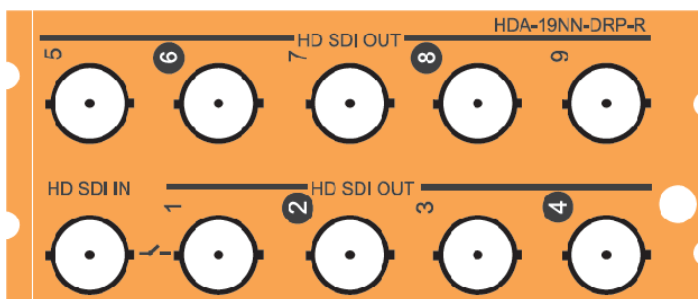

- **HDA-19NN-DRP-F** Double rear for 1x8 operating mode with fiber option support.

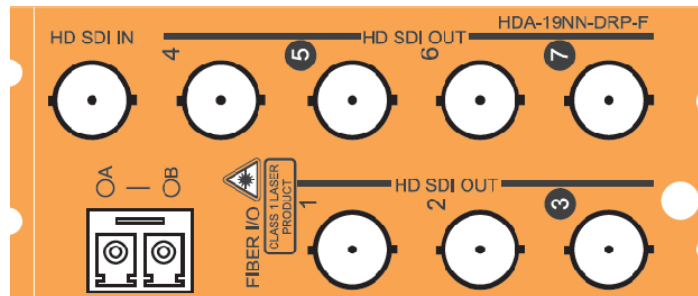

- **HDA-193N-DRP** Double rear for dual 1x4 operating mode (HDA-1931 only).

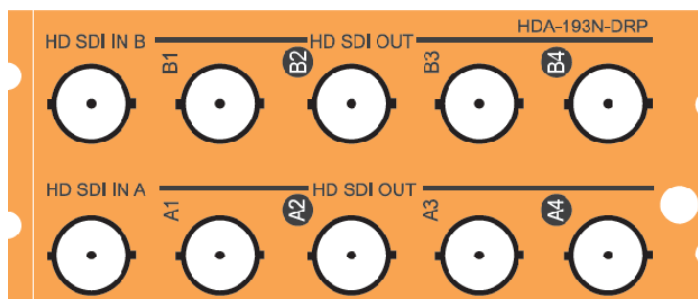

- **HDA-193N-DRP-F** Double rear for dual 1x3 operating mode with fiber option support (HDA-1931 only).

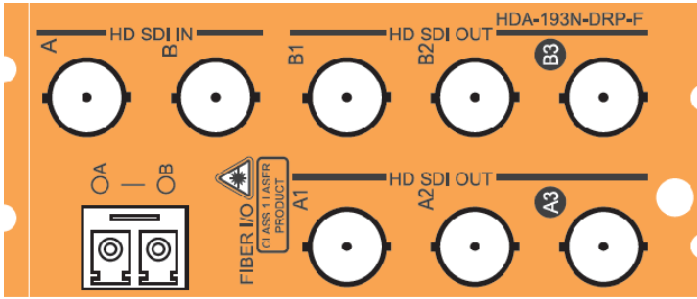

- **HDA-191N-3SRP** Single rear for 1x7 operating mode.

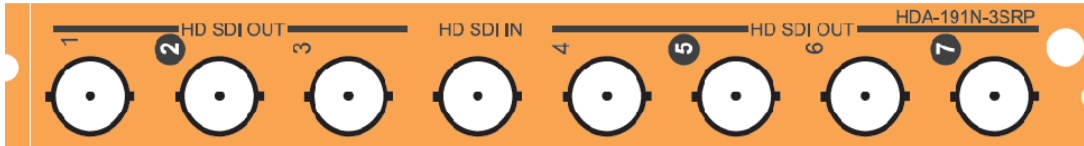

- **HDA-193N-3SRP** Single rear for dual 1x3 operating mode (HDA-1931 only).

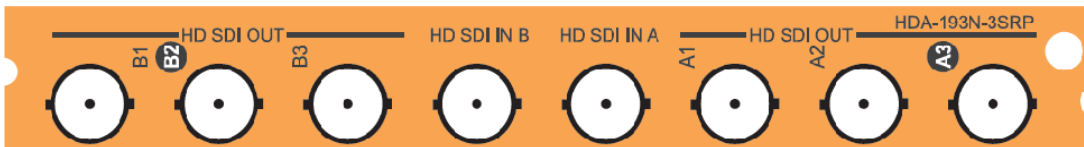

NOTE - The outputs labeled with white letters on a black circle DO NOT support ASI output

This table summarizes the input/output connections on the various rear panels shown above:

Rear panel type	I/O Connections			Bypass	Use with	
	HD-SDI IN	HD-SDI OUT	FIBER I/O		HDA-1911	HDA-1931
Densité-2 panels						
HDA-19NN-SRP	1	4			✓	✓
HDA-19NN-SRP-R	1	4		✓	✓	✓
HDA-19NN-SRP-F	1	2	✓		✓	✓
HDA-19NN-DRP	1	9			✓	✓
HDA-19NN-DRP-R	1	9		✓	✓	✓
HDA-19NN-DRP-F	1	7	✓		✓	✓
HDA-193N-DRP	2	2 x 4				✓
HDA-193N-DRP-F	2	2 x 3	✓			✓
Densité-3 panels						
HDA-191N-3SRP	1	7			✓	✓
HDA-193N-3SRP	2	2 x 3				✓

3 Operation

3.1 Control Options

The HDA-19x1 can be controlled in two different ways:

- The local control panel and its push-buttons can be used to move through a menu of parameters and to adjust parameter values (see section 3.3).
- Miranda’s iControl system can be used to access the card’s operating parameters from a remote computer, using a convenient graphical user interface (GUI). (see section 3.4)

3.2 Card-Edge Status LED

The status monitor LED is located on the front card-edge of the HDA-19x1, and is visible through the front access door of the DENSITÉ frame. This multi-color LED indicates the status of the HDA-19x1 by color, and by flashing/steady illumination.

The chart shows how the various error conditions that can be flagged on the HDA-19x1 affect the LED status.

- If a cell is gray, the error condition cannot cause the LED to assume that status
- If more than one LED status is possible for a particular error condition, the status is configurable. See Section 3.4.6 for details.
- The factory default status is shown by a ⚙

The LED will always show the most severe detected error status that it is configured to display, and in the chart error severity increases from left to right, with green representing no error/disabled, and flashing red the most severe error.

Error Condition	LED Status			
	Green	Yellow	Red	Flashing Red
No input signal presence			⚙	
No lock on input signal		⚙		
No fiber present when needed	⚙			
No rear				⚙

⚙ : Factory default.

If the LED is Flashing Yellow, it means that the card is selected for local control using the Densité frame’s control panel. See Section 3.3 for details.

The LED will be Yellow when the card is in the “Firmware Update” mode.

3.3 Local control using the Densité frame control panel

3.3.1 Overview

Push the SELECT button on the HDA-19x1 card edge (see Section 1.4) to assign the local control panel to operate the HDA-19x1. Use the control panel buttons to navigate through the menu, as described below.

All of the cards installed in a Densité frame are connected to the frame's controller card, which handles all interaction between the cards and the outside world. There are no operating controls located on the cards themselves. The controller supports remote operation via its Ethernet ports, and local operation using its integrated control panel.

The local control panel is fastened to the controller card by a hinged connector, and when installed is located in the front center of the frame, positioned in front of the power supplies. The panel consists of a display unit capable of displaying two lines of text, each 16 characters in length, and five pushbuttons.

The panel is assigned to operate any card in the frame by pushing the SELECT button on the front edge of that card.

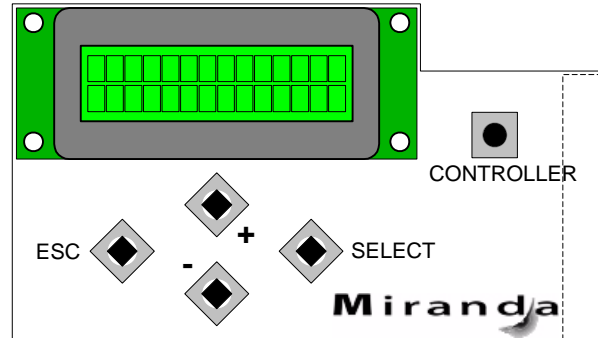

Figure 3.1 Densité Frame local control panel

- Pushing the CONTROLLER button on the control panel selects the Controller card itself.
- The STATUS LED on the selected card flashes yellow.

The local control panel displays a menu that can be navigated using the four pushbuttons located beneath the display. The functionality of the pushbuttons is as follows:

[+] [-] Used for menu navigation and value modification

[SELECT] Gives access to the next menu level. When a parameter value is shown, pushing this button once enables modification of the value using the [+] and [-] buttons; a second push confirms the new value

[ESC] Cancels the effect of parameter value changes that have not been confirmed; pushing [ESC] causes the parameter to revert to its former value.

Pushing [ESC] moves the user back up to the previous menu level. At the main menu, [ESC] does *not* exit the menu system. To exit, re-push the [SELECT] button for the card being controlled.

If no controls are operated for 30 seconds, the controller reverts to its normal standby status, and the selected card's STATUS LED reverts to its normal operating mode.

3.3.2 Menu for local control

The HDA-19x1 has operating parameters which may be adjusted locally at the controller card interface.

- Press the SELECT button on the HDA-19x1 front card edge to assign the Densité frame's local control panel to the HDA-19x1
- Use the keys on the local control panel to step through the displayed menu to configure and adjust the HDA-19x1.

The complete menu structure is shown in Annex 1 to this document, beginning on page 22.

3.4 Remote control using iControl

The operation of the HDA-19x1 may be controlled using Miranda's iControl system.

- This manual describes the control panels associated with the HDA-19x1 and their use.
- Please consult the iControl User's Guide for information about setting up and operating iControl.
- *Exception:* At the time of printing, the HDA-19x1 was not supported by iControl Solo

In iControl Navigator or iControl Websites, double-click on the HDA-19x1 icon to open the control panel.

3.4.1 The iControl graphic interface window

The basic window structure for the HDA-19x1 is shown in figure 3.2. The window identification line gives the card type (HDA-1911 or HDA-1931) and the slot number where the card is installed in its Densité frame.

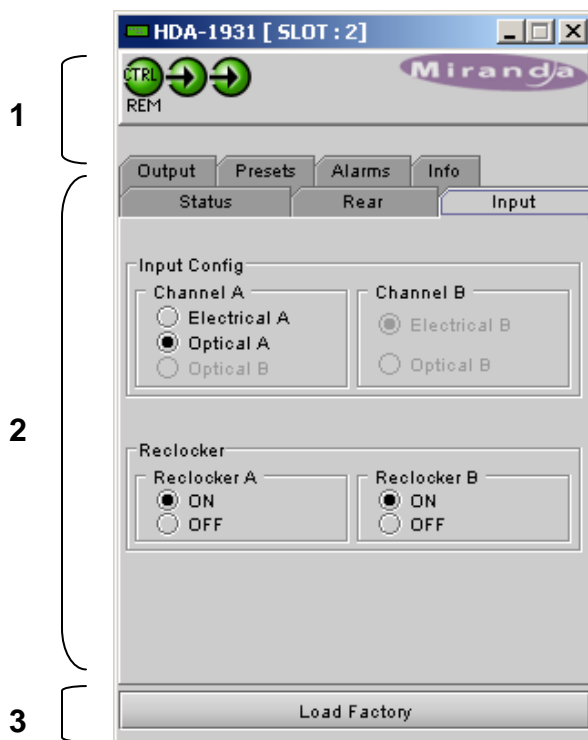

Figure 3.2 HDA-1931 iControl graphic interface window:

There are three main sections in the window itself, shown in Figure 3.2:

1. The top section displays icons on the left. These icons report the status of some parameters associated with this HDA-19x1. Figure 3.3 shows the three icons that appear.

Move the mouse over an icon and a status message appears below the icon providing additional information.

If there is an error, the error status message appears in the message area without mouse-over.

- If there are multiple errors, the error messages cycle
- The icon whose status or error message is shown is highlighted with a mauve background

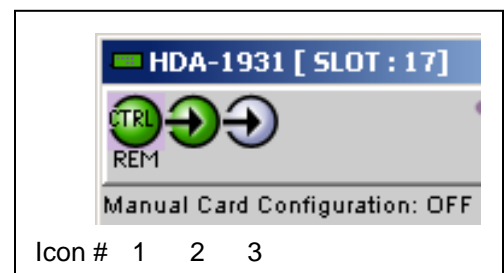









Figure 3.3 iControl Status Icons

The table below lists the various status icons that can appear, and how they are to be interpreted.

- In cases where there is more than one possible interpretation, read the error message in the iControl window to see which applies.

Table – iControl Status Icon interpretation

Icon #1 – Manual Card Configuration	
 <p>(green)</p>	Remote card control activated. The iControl interface can be used to operate the card
 <p>(yellow)</p>	Local card control active, The card is being controlled using the Densité frame control panel, as described in section 3.3. Any changes made using the iControl interface will have no effect on the card.
Icon #2 – Input A status	
 <p>(green)</p>	Signal detected and valid. <ul style="list-style-type: none"> • Beneath the icon, the format will be indicated as HD or SD, and the specific format details will be listed if the cursor is moved over the icon.
 <p>(red)</p>	Input signal error No rear
 <p>(grey)</p>	No electrical input
Icon #3 – Input B status	
 <p>(green)</p>	Signal detected and valid. <ul style="list-style-type: none"> • Beneath the icon, the format will be indicated as HD or SD, and the specific format details will be listed if the cursor is moved over the icon.
 <p>(red)</p>	Input signal error No rear
 <p>(grey)</p>	No electrical input

2. The center portion of the iControl graphic interface window contains a series of control and information panels, selected by tabs.

- Click on a tab to display the associated panel.
- Each of these panels is described individually in the following sections.

3. The Load Factory button is always visible at the bottom of the panel. Click the **Load Factory** button to reset all parameters on this HDA-19x1 card to factory default values.
 - The factory default values are shown underlined in the menus found in the Annex to this document, beginning on page 22.

3.4.2 The *Input* panel

This panel allows the user to select the input that will be processed through the available channels in the HDA-19x1.

HDA-1911: Only one channel is available, so channel B does not appear in the panel

HDA-1931: Two channels are available. The rear panel may have one or two electrical inputs, and may have two optical inputs. Channel B will be greyed out if no signal is available for it.

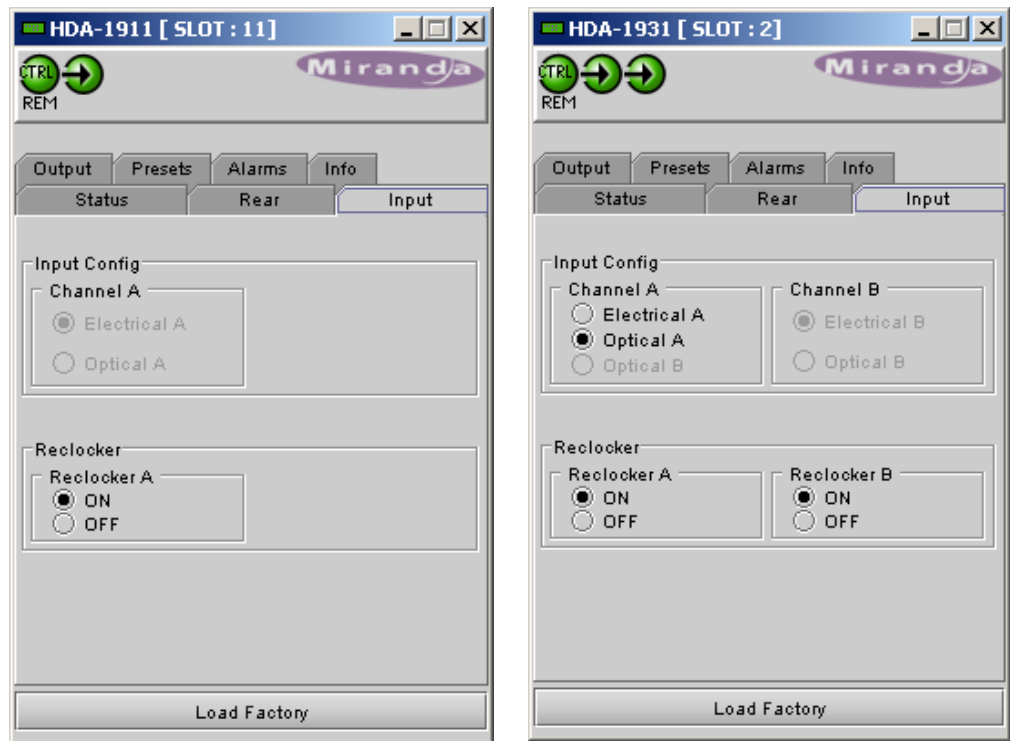

Figure 3.4 *Input panel – HDA-1911 (left) and HDA-1931 (right)*

Input Config

Select the input for Channel A and Channel B, using the radio buttons.

- Electrical Input A and Optical Input A can only go to Channel A
- Electrical Input B can only go to Channel B
- Optical Input B can go to either Channel A or Channel B

Reclocker

Use the radio buttons to independently turn the reclockers for Channels A and B ON or OFF

3.4.3 The Rear panel

This panel identifies the type of rear panel installed with this HDA-19x1.

The name of the installed rear panel appears in the data box.

- If no rear is installed, “No Rear” appears in the data box.

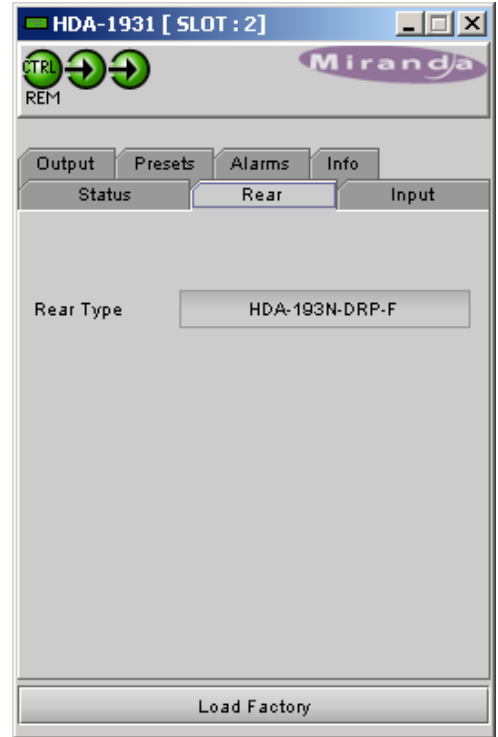

Figure 3.5 Rear panel

3.4.4 The Status panel

This panel shows the status of the various inputs to this HDA-19x1. For HDA-1911, only IN A is shown, because there is no IN B,

Electrical inputs (A and B)

Data rate (270 Mbps / 1.5 Gbps / 3 Gbps) – the detected input data rate is indicated by a green status icon

No Lock / No Signal – either of these conditions is indicated by a red status icon

Fiber

Module type: the type of fiber module installed in the rear panel will be shown in the text box:

- None
- Single RX
- Single TX
- Dual RX
- Dual TX
- Bidirectional

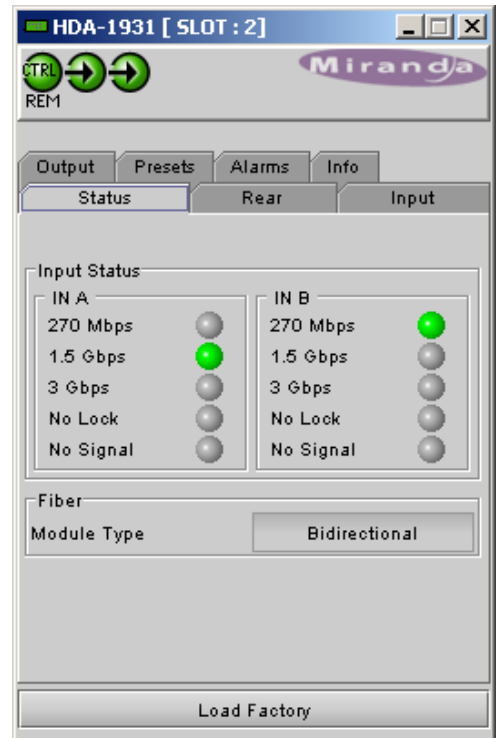

Figure 3.6 Status panel

3.4.5 The Output panel

This panel has two functions related the HDA-19x1 output:

Output Config

If an optical output is available, use the radio buttons to independently turn the two optical outputs OFF or ON

- Optical output is only available for rear panels with a Fiber I/O connector and an installed output (TX) cartridge
- Optical output A, if available, can only carry channel A
- Optical output B, if available, can carry either Channel A or Channel B on an HDA-1931, and the choice is made here. On an HDA-1911, only channel A is available, because there is no channel B.

MSB Output

Use the radio buttons to select which of the two channels in the HDA-1931 will be sent to the Monitoring Switching Bridge (if present) in the Densité frame.

This does not appear on the HDA-1911 because there is only one channel and no choice is necessary.

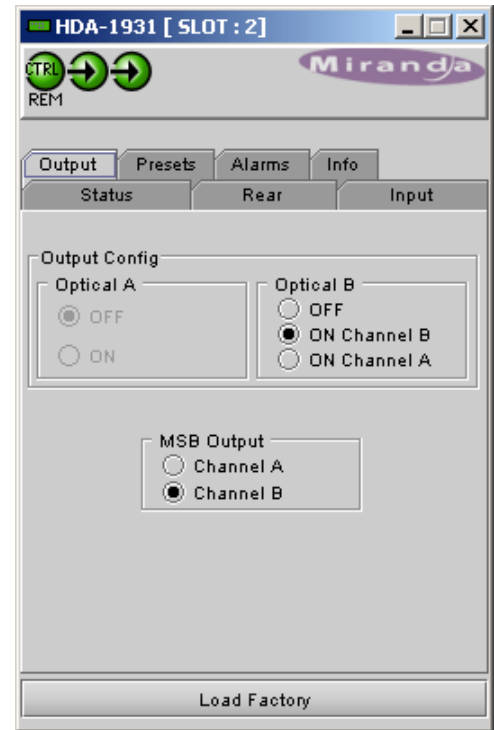

Figure 3.7 Output panel

3.4.6 The Alarms panel

This panel allows the alarm reporting of the HDA-19x1 to be configured.

Click on the Alarm Config button to open the Alarm Configuration window. The Alarm Configuration window is organized in columns

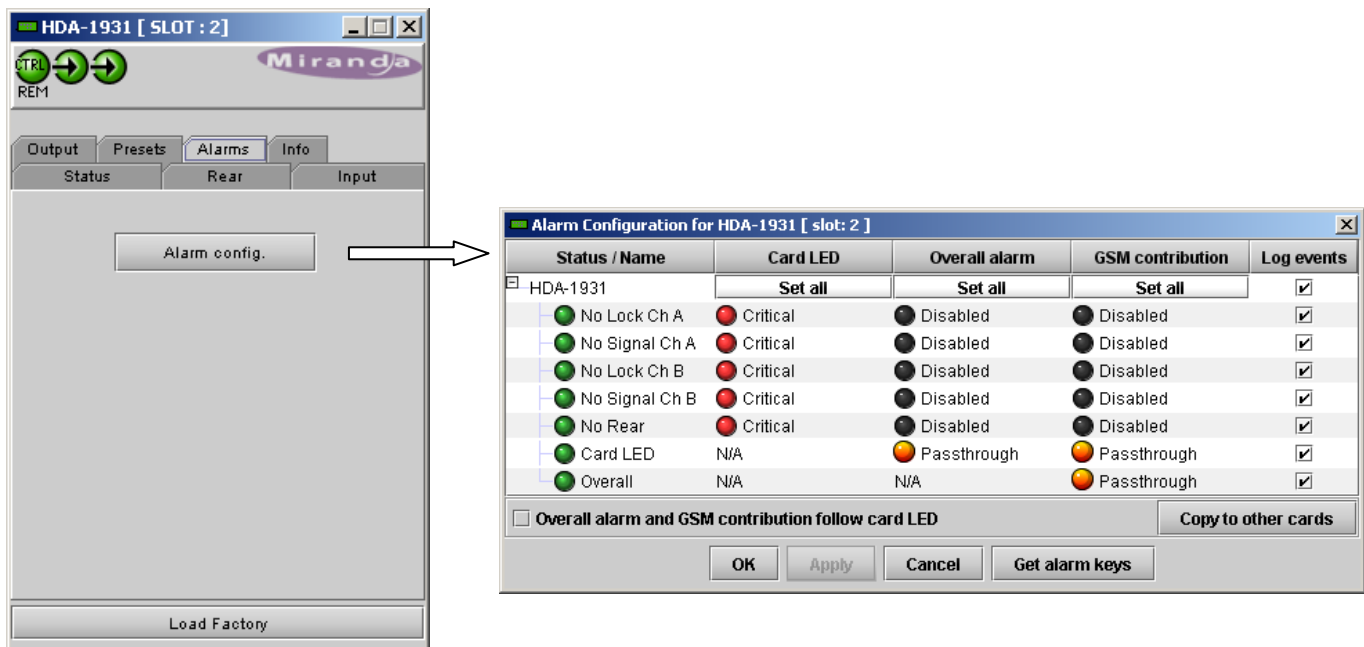

Figure 3.8 Alarms panel and Alarm Configuration window

Status/Name

This contains an expandable tree listing all the alarms reported by this HDA-19x1 card.

- Each alarm name includes an icon that shows its current status

The **Card LED**, **Overall alarm** and **GSM contribution** columns contain pulldown lists that allow the level of contribution of each individual alarm to the alarm named in the column heading to be set.

- If there is no arrowhead in the box, there is no pulldown and the alarm is not user-configurable

Card LED

This column allows configuration of the contribution of each individual alarm to the status reported by the Status LED on the front edge of the HDA-19x1 card, visible through the front door of the Densité frame.

Overall Alarm

This column allows configuration of the contribution of each individual alarm to the Overall Alarm associated with this card. The Overall Alarm is shown in the upper left corner of the iControl panel, and also appears at the bottom of the Status/Name column.





GSM Contribution

This column allows configuration of the contribution of each individual alarm to the GSM Alarm Status associated with this card. GSM is a dynamic register of all iControl system alarms, and is also an alarm provider for external applications. The possible values for this contribution are related to the Overall alarm contribution:

- If the Overall alarm contribution is selected as Disabled, the GSM alarm contribution can be set to any available value
- If the Overall alarm contribution is selected as any level other than disabled, the GSM contribution is forced to follow the Overall Alarm.

Levels associated with these alarms:

The pulldown lists may contain some or all of the following options:

 Disabled	The alarm makes no contribution (black icon)
 Minor	The alarm is of minor importance (yellow icon)
 Major	The alarm is of major importance (orange icon)
 Critical	The alarm is of critical importance (red icon)
 Passthrough	The alarm exists but has no effect (used for text and composite alarms)

Shortcut: if you click on one of the “Set All” boxes in the Card LED, Overall Alarm or GSM Contribution columns, you will open a pulldown that lets you assign a level to all alarms in that section of the column simultaneously.

Log Events

iControl maintains a log of alarm events associated with the card. The log is useful for troubleshooting and identifying event sequences. Click in the checkbox to enable logging of alarm events for each individual alarm.

At the bottom of the window are several other controls.

Copy to other cards

Click this button to open a panel that allows the alarm configuration set for this card to be copied into another HDA-19x1 card.

- Select one or more destination cards from the list in the window by clicking in the checkboxes, or all of them by clicking in the *All* checkbox

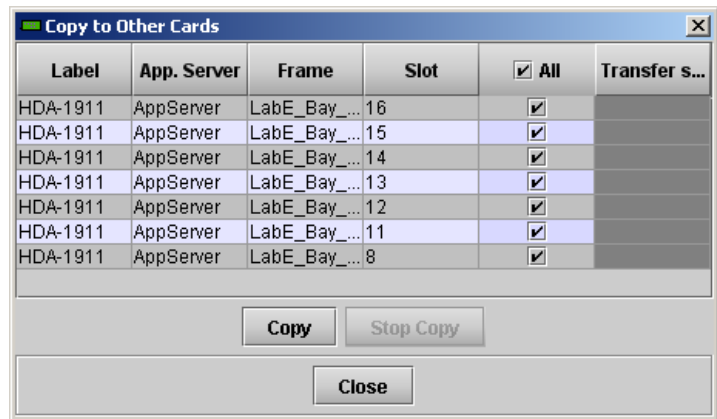

Figure 3.9 Copy to Other Cards

Get alarm keys

Click this button to open a save dialog where you can save a file containing a list of all alarms on this card and their current values, along with an Alarm Key for each. The alarm keys are useful for system integration and troubleshooting.

- The file is saved in .csv format

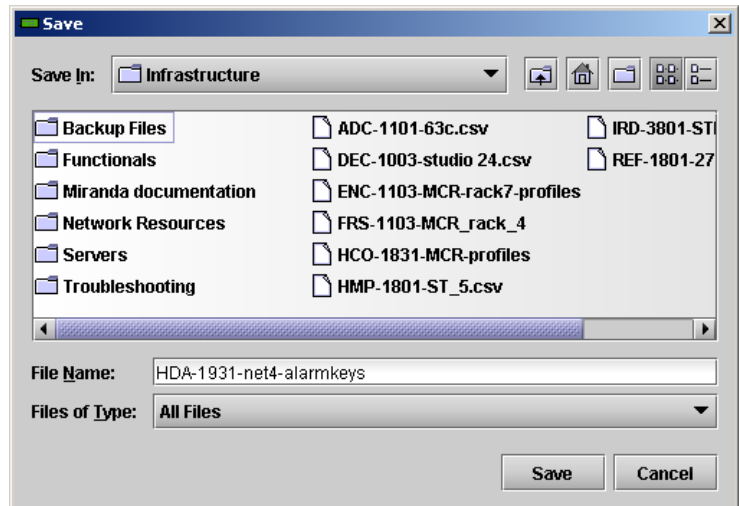

Figure 3.10 Save dialog for Get Alarm

OK, Apply, Cancel

- **OK** accepts the settings and closes the window once the card confirms that there are no errors.
- **Apply** accepts the settings, but leaves the window open
- **Cancel** closes the window without applying any changes, and leaves the previous settings intact.

3.4.7 The *Info* panel

When the HDA-19x1 is included in an iControl environment, certain information about the card should be available to the iControl system. The user can enter labels and comments that will make this card easy to identify in a complex setup. This information is entered into data boxes in the Info control panel.

- Label: type the label that is shown for this HDA-19x1 when it appears in iControl applications
- Short Label type the short-form label that iControl uses in some cases (8 characters)
- Source ID type a descriptive name for this HDA-19x1
- Comments: type any desired text

The remaining data boxes show manufacturing information about this card.

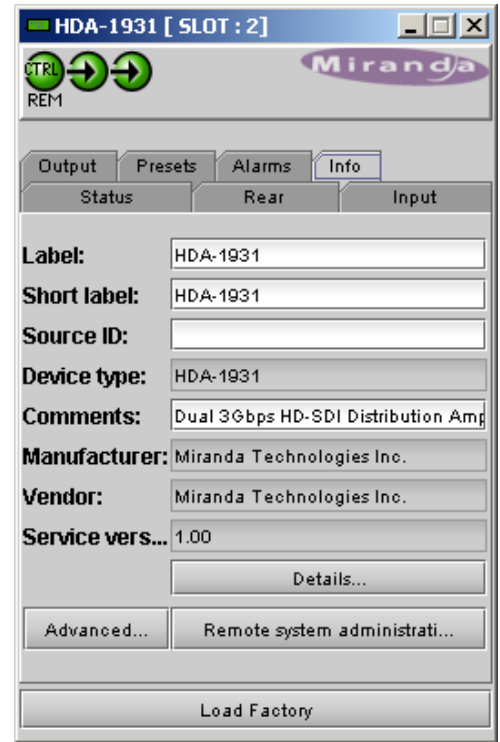

Figure 3.11 Info panel

Three buttons in the panel give access to other information.

- **Details...:** Reports the Firmware version, service version, and panel version for this card

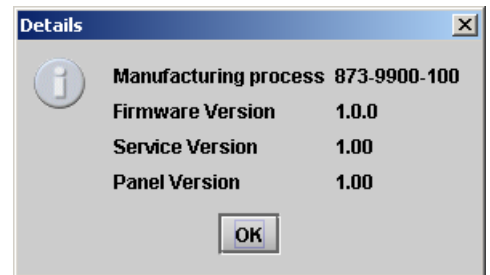

Figure 3.12 Details window

- **Advanced...:** Shows the Miranda LongID for this card. The Miranda LongID is the address of this HDA-19x1 in the iControl network.

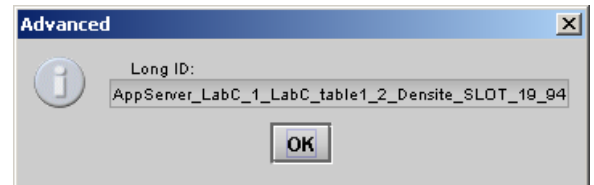

Figure 3.13 Advanced window

- **Remote System Administration:** opens the Joining Locators data box, which lists remote lookup services to which this HDA-19x1 is registered.

Add: Force the iControl service for this HDA-19x1 to register itself on a user-specified Jini lookup service, using the following syntax in the Input data box:

jini://<ip_address>

where <ip_address> is the ip address of the server running the lookup service

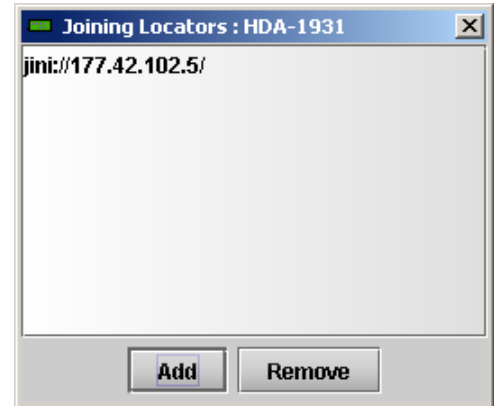
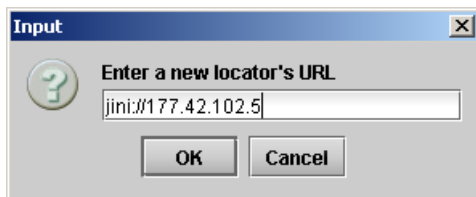

Figure 3.14 Joining Locators window

Remove: select one of the services listed in the Joining Locators window by clicking on it, and click *Remove* to delete it from the window. You will be asked to confirm the removal in a Query box.



3.4.8 The Presets panel

User Presets

The HDA-19x1 has memory registers which can hold up to 5 user-defined parameter settings.

Select any one of the five presets using the pull-down list. The name of the currently-selected User Preset is shown on the name bar.

Click **Load** to load the contents of the selected User Preset into the HDA-19x1. All parameter settings and values will be replaced by the contents of the selected User Preset.

Click **Save** to store the current parameter settings and values from the HDA-19x1 into the selected User Preset. The existing contents of the preset will be overwritten without asking for confirmation.

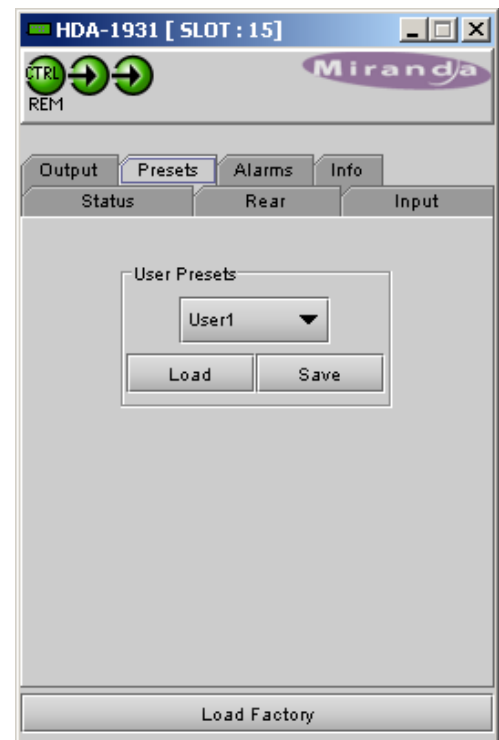

Figure 3.15 Presets panel

4 Specifications

ELECTRICAL INPUTS (2)

Signal:	HD/SD-SDI SMPTE 424M, 292M, and 259M-C compliant <ul style="list-style-type: none"> ➤ Supports data rates of 270, 1483.5, 1485, 2967, 2970Mb/s EN50 83-9 DVI-ASI 270 Mbps
Cable length:	90 m (180') @ 3 Gbps for Belden 1694A 140 m (360') @ 1.5 Gbps for Belden 1694A 300 m (1000') @ 270 Mbps for Belden 1694A
Return loss:	> 15 dB for up to 1.5GHz, > 10 dB from 1.5GHz to 3GHz

OPTICAL INPUTS (2)

Signal:	SMPTE 297M-2006 compliant HD/SD-SDI SMPTE 424M, 292M, and 259M-C compliant <ul style="list-style-type: none"> ➤ Supports data rates of 270, 1483.5, 1485, 2967, 2970Mb/s EN50 83-9 DVI-ASI 270 Mbps
Cable length:	15km of SMF fiber (9/125) at wavelengths between 1260nm and 1600nm.

ELECTRICAL OUTPUTS (9)

Signal:	HD/SD-SDI SMPTE 424M, 292M, and 259M-C compliant <ul style="list-style-type: none"> ➤ Supports data rates of 270, 1483.5, 1485, 2967, 2970Mb/s EN50 83-9 DVI-ASI 270 Mbps (5 outputs only)
Return loss:	> 15 dB for up to 1.5GHz, > 10 dB from 1.5GHz to 3GHz
Jitter (wideband):	< 0.2 UI p-p
Rise / Fall time	135 ps max., 20% to 80%, for HD 400 – 800 ps, 20% to 80%, for SD

OPTICAL OUTPUTS (2)

Signal:	HD/SD-SDI SMPTE 424M, 292M, and 259M-C compliant <ul style="list-style-type: none"> ➤ Supports data rates of 270, 1483.5, 1485, 2967, 2970Mb/s EN50 83-9 DVI-ASI 270 Mbps (AFV only)
Wavelength	1310 nm
Optical output power	-6 dBm typical

HD / SD INTRA-FRAME OUTPUT

Signal (1):	HD/SD-SDI SMPTE 424M, 292M, and 259M-C compliant <ul style="list-style-type: none"> ➤ Supports data rates of 270, 1483.5, 1485, 2967, 2970Mb/s EN50 83-9 DVI-ASI
Jitter (wideband):	< 0.2 UI p-p

PROCESSING PERFORMANCE

Signal path:	10 bits
Processing delay:	< 6 ns
Power:	< 5 W

ANNEX 1 – HDA-1911/1931 Local User Interface

HDA-1911

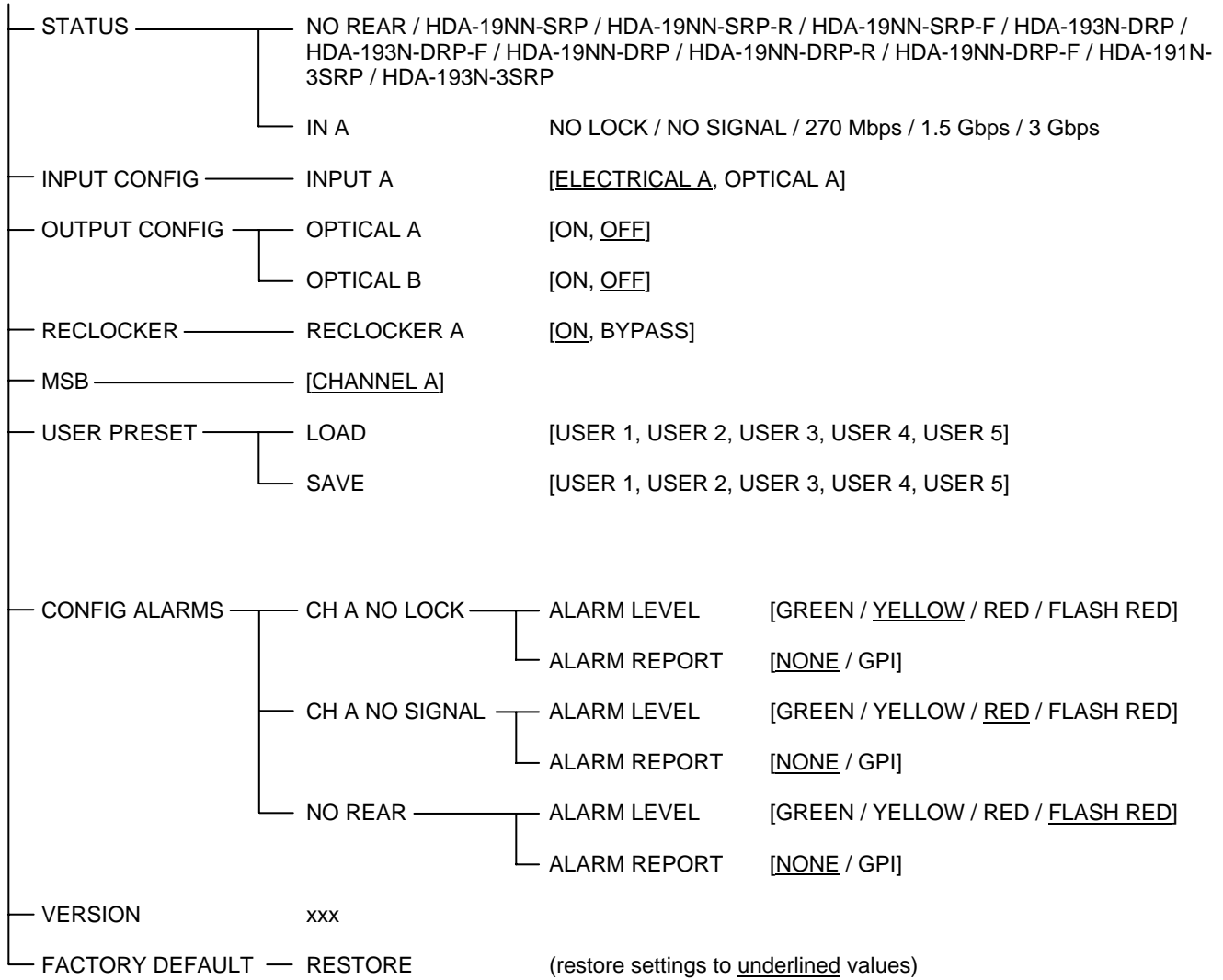

HDA-1931

STATUS	NO REAR / HDA-19NN-SRP / HDA-19NN-SRP-R / HDA-19NN-SRP-F / HDA-193N-DRP / HDA-193N-DRP-F / HDA-19NN-DRP / HDA-19NN-DRP-R / HDA-19NN-DRP-F / HDA-191N-3SRP / HDA-193N-3SRP		
	IN A	NO LOCK / NO SIGNAL / 270 Mbps / 1.5 Gbps / 3 Gbps	
	IN B	NO LOCK / NO SIGNAL / 270 Mbps / 1.5 Gbps / 3 Gbps	
	NO FIBER MODULE / RX FIBER PRESENT / TX FIBER PRESENT		
INPUT CONFIG	INPUT A	[<u>ELECTRICAL A</u> , OPTICAL A, OPTICAL B]	
	INPUT B	[<u>ELECTRICAL B</u> , OPTICAL B]	
OUTPUT CONFIG	OPTICAL A	[<u>OFF</u> , ON]	
	OPTICAL B	[<u>OFF</u> , ON]	
RECLOCKER	RECLOCKER A	[<u>ON</u> , BYPASS]	
	RECLOCKER B	[<u>ON</u> , BYPASS]	
OPERATING MODE	[<u>DUAL CHANNEL</u> , SINGLE CHANNEL]		
MSB	[<u>CHANNEL A</u> , CHANNEL B]		
USER PRESET	LOAD	[USER 1, USER 2, USER 3, USER 4, USER 5]	
	SAVE	[USER 1, USER 2, USER 3, USER 4, USER 5]	
CONFIG ALARMS	CH A NO LOCK	ALARM LEVEL	[GREEN / <u>YELLOW</u> / RED / FLASH RED]
		ALARM REPORT	[<u>NONE</u> / GPI]
	CH A NO SIGNAL	ALARM LEVEL	[GREEN / YELLOW / <u>RED</u> / FLASH RED]
		ALARM REPORT	[<u>NONE</u> / GPI]
	CH B NO LOCK	ALARM LEVEL	[GREEN / <u>YELLOW</u> / RED / FLASH RED]
		ALARM REPORT	[<u>NONE</u> / GPI]
	CH B NO SIGNAL	ALARM LEVEL	[GREEN / YELLOW / <u>RED</u> / FLASH RED]
		ALARM REPORT	[<u>NONE</u> / GPI]
	NO REAR	ALARM LEVEL	[GREEN / YELLOW / RED / <u>FLASH RED</u>]
		ALARM REPORT	[<u>NONE</u> / GPI]
VERSION	xxx		
FACTORY DEFAULT	RESTORE	(restore settings to <u>underlined</u> values)	

ANNEX 2 – Installing the Optical Interface

Installing and removing the Fiber I/O interface cartridge requires special care. This annex describes the process.

Some rear panels used with the HDA-19x1 incorporate a fiber optic interface. The interface consists of two parts:

- A socket on the rear panel into which an interface module is plugged
- An SFP (Small Form-factor Pluggable) module into which the optical fibers are plugged, and which incorporates the optical/electrical interface

Cautions and Warnings



SFP Transmitter modules contain a class 1 laser, which emits invisible radiation whenever the module is powered up. Because the SFP is hot-swappable, the module may be powered up as soon as it is installed.

DO NOT LOOK INTO AN OPERATING SFP MODULE'S CONNECTORS, AS EYE DAMAGE MAY RESULT.



The SFP module is sensitive to electrostatic discharge (ESD). It is recommended that you use an ESD-preventive wrist strap grounded to the Densité chassis while handling the SFP module.



SFP modules are subject to wear, and their useful lifetime is reduced each time they are inserted or removed. Do not remove them more often than is absolutely necessary.



Never remove or install an SFP module with the fiber optic cables connected. Damage to the cables could result.



The presence of dust and debris can seriously degrade the performance of an optical interface. It is recommended that you insert a dust plug into the SFP module whenever a fiber optic cable is not connected.

Installing an SFP module

1. Make sure that the bale clasp lever is in the closed position

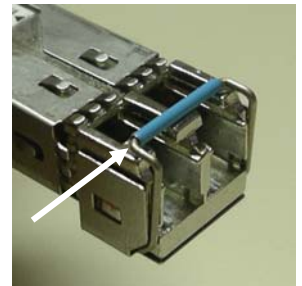

2. Position the SFP module so that the recessed slot is lined up with the tab side of the socket.

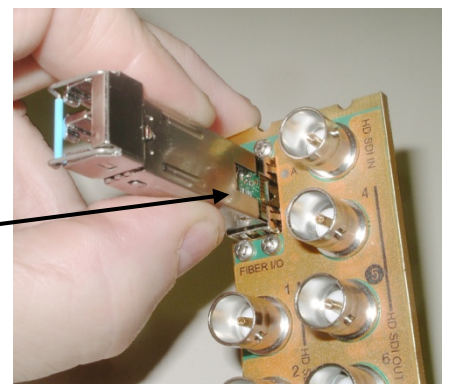
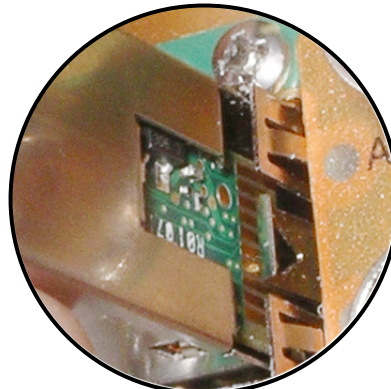

- Slide the module straight into the socket, and push gently until it clicks into position.

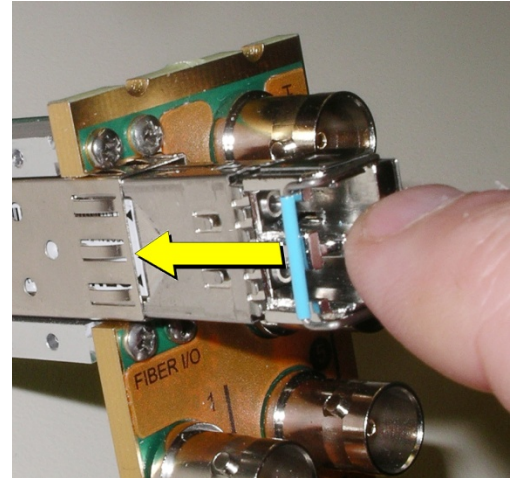

Connecting the fiber optic cables

- Remove the dust plug from the SFP module if present
- Verify that the exposed end of the optical fiber in the LC connector is clean
 - Carefully remove any debris if necessary.
- Plug the LC-terminated fiber optic cable into the SFP module

Removing the fiber optic cables

- Grasp the LC fiber optic connector that is plugged into the SFP module, and pull it straight out to disengage the optical fiber from the SFP.
 - Never pull the fiber optic cable itself, as catastrophic damage may occur.
- Insert a dust plug into the SFP module.

Removing the SFP module

- Move the bale clasp lever to the open position.

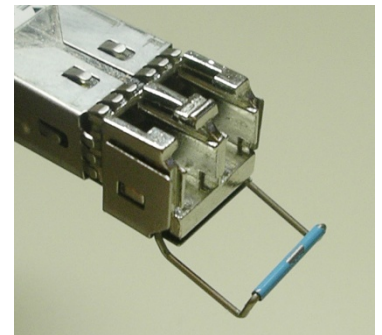

- Grasp the SFP module between your thumb and forefinger, and pull it straight out of the slot.
 - Do NOT pull on the bale clasp lever to remove the module, as it is easily damaged
 - You may find that you need to wiggle the module, or perhaps push it into the slot a bit, before it will release and slide out.

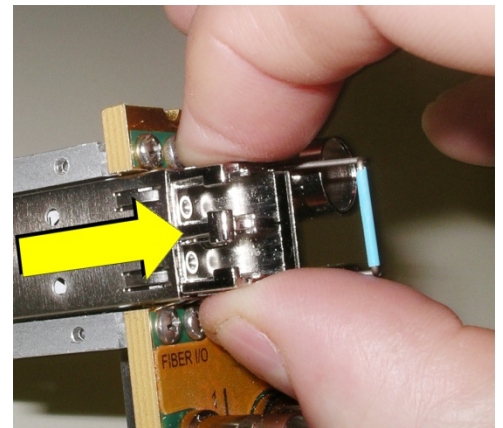

- Insert a dust plug into the SFP module.