



grass valley

A **BELDEN** BRAND

AMX-3981

3G/HD/SD 8 AES AUDIO & METADATA EMBEDDER

Guide to Installation and Operation

M922-9900-312

2018-12-05 (supersedes version dated 2016-05-02)

www.grassvalley.com

Copyright and Trademark Notice

Copyright © 2010-2018, Grass Valley Canada. All rights reserved.

Belden, Belden Sending All The Right Signals, and the Belden logo are trademarks or registered trademarks of Belden Inc. or its affiliated companies in the United States and other jurisdictions. Grass Valley, Miranda, AMX-3981, iControl, and Densité are trademarks or registered trademarks of Grass Valley Canada. Belden Inc., Grass Valley USA, LLC, and other parties may also have trademark rights in other terms used herein.

Product Patents

This product may be protected by one or more patents. For further information, please visit:

www.grassvalley.com/patents/

Terms and Conditions

Please read the following terms and conditions carefully. By using AMX-3981 documentation, you agree to the following terms and conditions.

Grass Valley hereby grants permission and license to owners of AMX-3981 to use their product manuals for their own internal business use. Manuals for Grass Valley products may not be reproduced or transmitted in any form or by any means, electronic or mechanical, including photocopying and recording, for any purpose unless specifically authorized in writing by Grass Valley.

A Grass Valley manual may have been revised to reflect changes made to the product during its manufacturing life. Thus, different versions of a manual may exist for any given product. Care should be taken to ensure that one obtains the proper manual version for a specific product serial number.

Information in this document is subject to change without notice and does not represent a commitment on the part of Grass Valley.

Warranty information is available in the Support section of the Grass Valley Web site (www.grassvalley.com).

Electromagnetic Compatibility



This equipment has been tested for verification of compliance with FCC Part 15, Subpart B requirements for Class A digital devices.

NOTE: This equipment has been tested and found to comply with the limits for a Class A digital device, pursuant to part 15 of the FCC Rules. These limits are designed to provide reasonable protection against harmful interference when the equipment is operated in a commercial environment. This equipment generates, uses, and can radiate radio frequency energy and, if not installed and used in accordance with the instruction manual, may cause harmful interference to radio communications. Operation of this equipment in a residential area is likely to cause harmful interference in which case the user will be required to correct the interference at his own expense.



This equipment has been tested and found to comply with the requirements of the EMC directive 2004/108/CE:

- EN 55022 Class A radiated and conducted emissions
- EN 55024 Immunity of Information Technology Equipment
- EN 61000-3-2 Harmonic current injection
- EN 61000-3-3 Limitation of voltage changes, voltage fluctuations and flicker
- EN 61000-4-2 Electrostatic discharge immunity
- EN 61000-4-3 Radiated electromagnetic field immunity – radio frequencies
- EN 61000-4-4 Electrical fast transient immunity
- EN 61000-4-5 Surge immunity
- EN 61000-4-11 Voltage dips, short interruptions and voltage variations immunity

Manufactured under license from Dolby Laboratories. Dolby and the Double-D symbol are trademarks of Dolby Laboratories.

Table of Contents

1 AMX-3981 3G/HD/SD 8 AES Audio & Metadata Embedder 7

1.1 Introduction 7

1.2 Features..... 8

1.3 Functional Block Diagram..... 9

1.4 Front Card-edge Interface 9

2 Installation 10

2.1 Installation of Rear Connector Panels 10

2.2 AMX-3981 Card Installation..... 11

2.3 Installation of the Optical Interface (option)..... 11

2.4 Rear Panels and Connectors 11

2.4.1 Images of Rear Panel Connectors 11

2.4.2 Summary of rear panel connections..... 12

2.4.3 Details of rear panel connections 12

3 User Interface 16

3.1 Control options 16

3.2 Card-Edge Status LED 16

4 Local control using the Densité frame control panel 17

5 Remote control using iControl 18

5.1 The iControl graphic interface window 18

5.2 Video Input/Output panel..... 21

5.2.1 Fiber Input/Output tab..... 21

5.2.2 Deglitcher tab 22

5.2.3 Freeze tab 24

5.2.4 Timing tab..... 25

5.2.5 SFP Info tab..... 26

5.3 Metadata panel..... 26

5.3.1 LTC tab..... 27

5.3.2 GPI tab 27

5.3.3 AFD tab 29

5.4 Audio Processing panel..... 31

5.4.1 Audio Proc – Levels tab 32

5.4.2 Audio Proc – Fixed Delay tab..... 33

5.4.3 Audio Proc – Silence tab 34

5.4.4 Downmix..... 34

5.4.5 AES Inputs tab..... 37

5.4.6 Status tab 37

5.5 Miranda ALC panel..... 38

5.5.1 Config tab 38

5.5.2 PGM1-8 tabs 39

5.6 Dynamic Processing panel..... 41

5.7 Audio Modules panel..... 43

5.8	Dolby Metadata panel	44
5.8.1	Config tab	44
5.8.2	Input/Output tab	52
5.9	Audio Output panel	53
5.9.1	CH 1-2, CH 3-4, ... CH 15-16 tabs	53
5.9.2	Config tab	54
5.10	Loudness Panel	55
5.10.1	Loudness Config panel	55
5.10.2	Loudness PGM panel	57
5.10.3	Loudness Logging Panel	59
5.11	Fingerprint panel	60
5.12	Reference panel	61
5.13	Monitoring panel	61
5.13.1	Thumbnails tab	61
5.13.2	RALM tab	62
5.14	Test panel	63
5.15	Factory/Presets panel	64
5.15.1	<i>Factory/Presets tab</i>	64
5.15.2	<i>Automatic Preset Recall tab</i>	68
5.16	Options panel	72
5.16.1	Dynamic Processing option:	72
5.16.2	ALC option	73
5.17	Alarm Config panel	74
5.18	Info panel	77
6	Audio Modules	79
6.1	Dolby E and Dolby Digital decoder	79
6.1.1	Control tab	79
6.1.2	Dolby E tab	80
6.1.3	Dolby Digital tab	81
6.1.4	PCM tab	81
6.2	Dolby Digital and Dolby Digital Plus encoder	82
6.2.1	Shuffler Inputs	82
6.2.2	Configuration	82
6.2.3	Status:	83
6.3	Dolby E encoder	84
6.3.1	Input and Output channel selection	84
6.3.2	Configuration	84
6.3.3	Status:	85
6.4	Upmixing using Linear Acoustic Technology upMAX™	85
6.5	N-channel ALC and upmix licensed by Linear Acoustic	87
6.5.1	Config tab	89
6.5.2	Basic tab	90
6.5.3	Advanced Configuration – ALC PGM 1 & 2	90
6.5.4	Upmix using Linear Acoustic UpMAX™	96

7 Specifications	97
8 Contact Us	99
Grass Valley Technical Support	99
Corporate Head Office.....	99
ANNEX 1 – AMX-3981 Local User Interface.....	100
ANNEX 2 – Installing the Optical Interface.....	101
ANNEX 3 – Installing the Audio Modules	104
ANNEX 4 – Dolby Digital Main Channel Output Functions	107
ANNEX 5 – AFD Flags	108
ANNEX 6 – Loudness Logging and the Audio Loudness Analyzer	110

1 AMX-3981 3G/HD/SD 8 AES Audio & Metadata Embedder

1.1 Introduction

The AMX-3981 is an advanced, high quality audio processor which embeds up to eight (8) AES signals into a 3G/HD/SD video signal. Each AES input can accept different sample rates, or even asynchronous audio, and will be resampled at 48 kHz by a sample rate converter, which can be manually or automatically disabled in the presence of non-PCM audio.

The AMX-3981 can simultaneously process up to 32 channels of audio (16 channels from the discrete AES inputs, and 16 channels of embedded audio). Functions include down-mixing, Proc Amp, channel shuffling, mixing and loudness measurement. Options include Automatic Loudness Control and dynamic processing (limiter, compressor, and expander). The AMX-3981 generates audio/video fingerprints (via an iControl option) to detect and measure lip-sync errors in a broadcast facility.

The loudness measurement feature allows the measurement and logging of up to 4 audio programs with iControl Loudness Monitoring software to analyze and report compliance with respect to various loudness legislations around the world (See iControl Loudness Monitoring).

The AMX-3981 has one on-board socket for optional modules, including Dolby E and Dolby Digital decoding, upmixing using Linear Acoustic upMAX™ technology, Dolby E encoding, Dolby Digital and Dolby Digital Plus encoding. In addition to Grass Valley's own automatic loudness control (ALC) solution for up to eight programs, the AMX-3981 offers ALC using the AEROMAX™ technology by Linear Acoustic, implemented using optional modules.

The card will pass and delay automatically all 32 internal audio channels to preserve lip-sync between the channels. Each channel can be delayed independently to correct any lip-sync issues. All audio channels can be mixed and shuffled to provide 16 channels for embedding in the video output.

An Automatic Preset Recall feature provides basic automation to select user preset based on the status of the incoming audio.

When genlocked to the frame reference using the internal URS signal, the AMX-3981 can handle video hot switches at the input without losing sync at the output. In the absence of a video input, the card can still output synchronous video and embed the discrete AES audio.

The card has a frame buffer (not a frame sync) which allows an increase in the video delay of up to 15 frames to compensate for the long audio processing delay required by some modules. For applications which require a small processing delay, the frame buffer can be bypassed to reduce the delay to a few micro-seconds.

The AMX-3981 can embed Linear Time Code (LTC) as ancillary Time Code (ATC) in 3G/HD and DVITC in SD. Up to 3 GPIO can be used as input, or output, to embed or extract GPI events to/from the Time Code user bits in transport applications. They can also be used simultaneously to trigger the card's user presets.

Dolby Metadata insertion in the VANC is possible from multiple sources, such as a Dolby E decoder module, an embedded VANC stream, an external RS-422 link, or from the integrated Metadata generator. All parameters in the Metadata stream can be probed and monitored. Dolby Metadata can be used to steer the behavior of the audio downmix and upmix modules.

A fiber input/output cartridge is offered as an option on some rear modules. Once the cartridge is installed, the inputs or outputs are selectable through the control interface. The input of the card allows you to select between fiber and copper inputs. The outputs are via copper and fiber simultaneously (with appropriate fiber cartridge).



1.2 Features

Video

- 3G/HD/SD input
- Supports 3G level A (mapping 1) and level B
- Audio/Video deglitcher to handle video hot switch at the input
- Automatic detection of input video loss and switchover to local black for continuity of embedded audio
- Flexible HD/SD reference using the internal URS frame reference
- Minimum processing delay of 7.5 μ s (HD), but additional delay can be added up to 15 frames
- Optional optical fiber module
- Compatible with iControl end-to-end A/V fingerprint analyzer for lip sync error detection and measurement

Audio

- 8 AES inputs
- Sample rate conversion for asynchronous AES inputs
- Full audio shuffling and mixing on a channel basis
- 32 channels internal audio processing
- Audio 5.1 surround down-mix to Lt/Rt or Lo/Ro
- Audio dynamic processor option (compressor/limiter/expander)
- Optional on-board Automatic Loudness Control with Grass Valley Wideband processing
- Loudness measurement of up to 4 audio programs and logging with iControl
 - Loudness compliant to EBU R128, ATSC A/85 and ARIB TR-B32 (ITU-R BS.1770-3)
- Audio delay adjustments of up to 2 seconds to compensate for lip-sync issues
- A/V fingerprint generation (an iControl option) for lip-sync measurement
- On-board socket for 1 optional expansion module:
 - Dolby E and Dolby Digital decoder module
 - Dolby E encoder module
 - Dolby Digital and Dolby Digital Plus encoder module
 - Linear Acoustic upMAX™ audio stereo to 5.1 upmixing
 - Linear Acoustic AEROMAX™ Automatic Loudness Control

Metadata

- AFD (SMPTE-2016), VLI (RP-186) and WSS insertion
- Linear Time Code (LTC) embedding into DVITC (SD) or ATC (HD)
- Dolby Metadata insertion and extraction (SMPTE 2020)
- RS-422 serial data input & output to carry audio metadata
- GPI inputs & outputs that can be inserted or extracted from the embedded timecode user bits. They can also be used for automation, user preset recall and loudness reset.

1.3 Functional Block Diagram

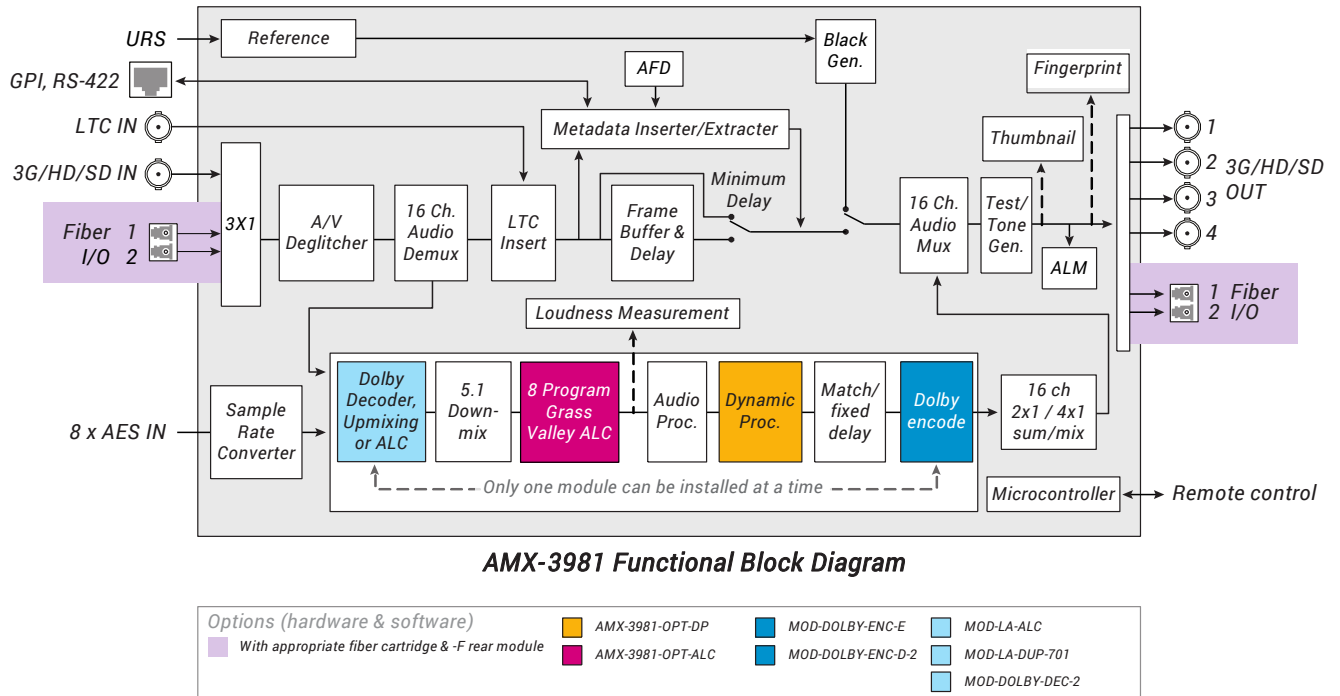

Figure 1.1 AMX-3981 Functional Block Diagram

1.4 Front Card-edge Interface

The front card-edge of the AMX-3981 incorporates two elements:

- Status LED (see section 3.2)
- Select Button (see section 4)

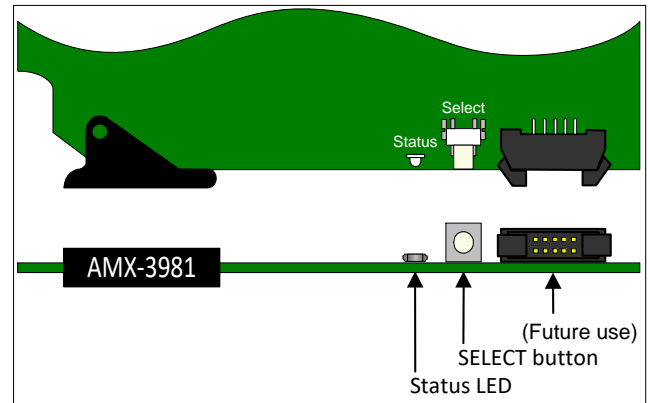

Figure 1.2 Front card-edge layout

2 Installation

2.1 Installation of Rear Connector Panels

Grass Valley Densité-series cards are each associated with a rear connector panel, which must be installed in the Densité frame before the card can be inserted.

The AMX-3981 card is designed to fit into Grass Valley's Densité-3 frame. Four different rear connector panels are available:

- AMX-3981-75D-3SRP Single-slot-width panel with 75Ω audio
- AMX-3981-110-3SRP Single-slot-width panel with 75Ω audio
- AMX-3981-75-3DRP-F Double-slot-width panel with 75Ω audio and fiber I/O
- AMX-3981-110-3DRP-F Double-slot-width panel with 110Ω audio and fiber I/O

See section 2.4 for details of the signal connections available on each of these panel types.

All cards and rear panels can be installed with the frame power on. The card has connectors which plug into a mid-frame mother board for distribution of power and for connection to the controller card, and a second connector which plugs directly into the rear connector panel for input and output.

The rear connector panel must be installed with the card out of the frame.

- To remove an existing card from the slot, tilt up the swivel handle on the front of the card to lever the connectors apart, then use the handle to pull the card straight out of the slot.

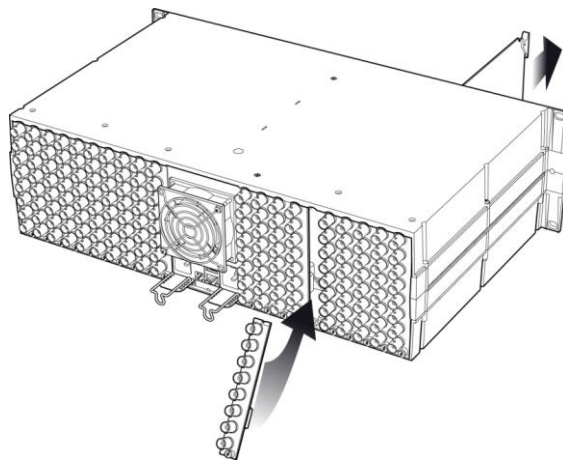

Figure 2.1 Densité-3 frame – rear panel installation

To install the connector panel:

1. If a card is installed in the slot whose rear panel is being changed, remove it as described above.
2. Remove the existing panel (either blank or belonging to an existing card that is being changed) by releasing the captive screw(s) at the bottom.
3. Position the new panel and secure it in place with the captive screw(s) at the bottom.

2.2 AMX-3981 Card Installation

Once a matching rear connector panel has been installed, install the AMX-3981 card as follows:

1. Open the front panel of the frame.
2. Slide the AMX-3981 card into the slot and push gently on the handle to seat the connectors.

When using a double-slot-width rear panel, the card should be inserted into the right-most of the two slots. Inserting the card into the wrong slot will not damage the card, and will be flagged by the on-card status LED flashing red to indicate that there is no connection to the rear panel.

3. Close the front panel of the frame.

2.3 Installation of the Optical Interface (option)

Refer to [ANNEX 2 – Installing the Optical Interface](#).

2.4 Rear Panels and Connectors

2.4.1 Images of Rear Panel Connectors

The four available rear panels are shown in the figure below, and their various inputs and outputs are described.

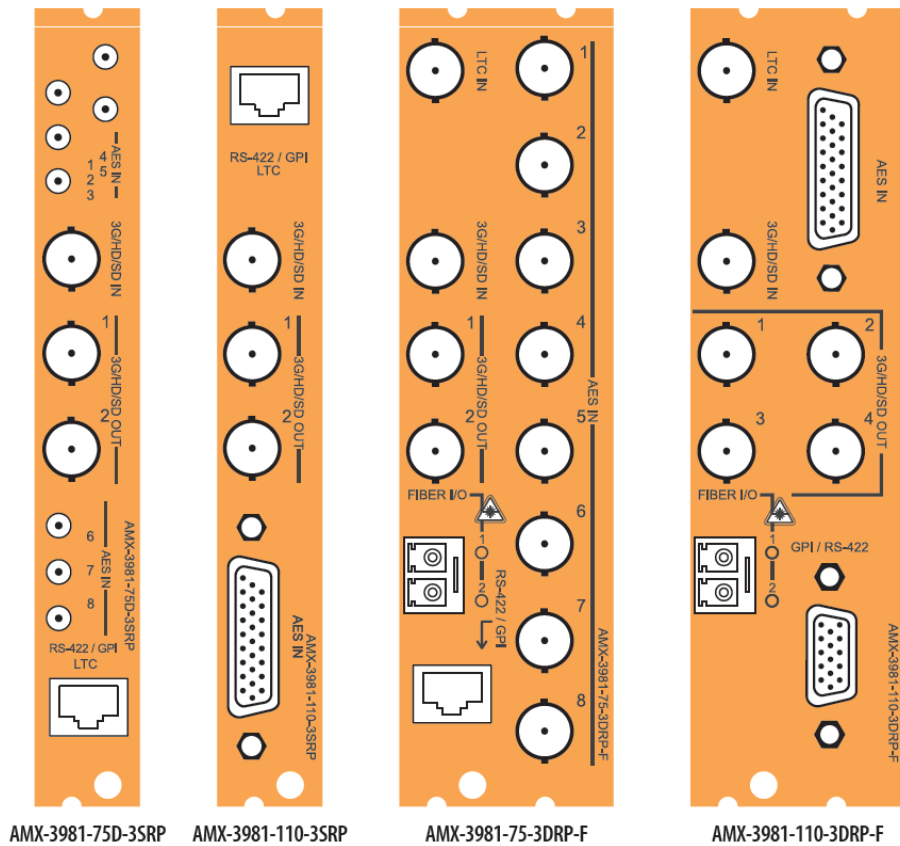

2.4.2 Summary of rear panel connections

AMX-3981-75D-3SRP				
AMX-3981-110-3SRP				
AMX-3981-75-3DRP-F				
AMX-3981-110-3DRP-F				
Single-slot-width panel			◆	◆
Double-slot-width panel	◆	◆		
CONNECTORS				
3G/HD/SD IN	1	1	1	1
3G/HD/SD OUT	4	2	2	2
AES IN (110Ω) on D-SUB	8		8	
AES IN (75Ω) on BNC		8		8
GPI (#) & RS-422 on D-SUB	3			
GPI (#) and RS-422 A on RJ45		3		
LTC IN on BNC	◆	◆		
GPI (#), LTC IN and RS-422 A on RJ45			2	2
Fiber I/O module	◆	◆		

2.4.3 Details of rear panel connections

3G/HD/SD SDI IN – Serial digital 3G/HD/SD input

Connect a serial digital video signal, conforming to the SMPTE 425M standard for 3G input signals, SMPTE 292M standard for HD input signals or SMPTE 259M standard for SD input signals, to the BNC labeled **3G/HD/SD SDI IN**. The AMX-3981 will automatically switch to the detected line/frame rate format.

- Note: if you are using the Densité frame's URS signal as the reference, then you must make sure that the input SDI is locked to the URS.

3G/HD/SD SDI OUT – Serial digital video outputs

The AMX-3981 provides two or four (depending upon the rear panel in use) 3G/HD/SD SDI video outputs on BNC connectors, labeled **3G/HD/SD OUT 1, 2, 3 and 4**. The SDI video signal conforms to the SMPTE 425M, SMPTE 292M or SMPTE 259M-C standard. The same signal is carried on all outputs.

AES IN – Discrete AES3 digital audio inputs (8)

The AES inputs can be configured for 110 ohm impedance using a 26-pin D-SUB connector, or 75 ohm impedance using BNC or DIN 1.0/2.3 connectors. Rear connector panels are available for each option.

Rear Panel Type	Connector(s) / Impedance
AMX-3981-110-3DRP-F	D-SUB 26 (1) 110Ω
AMX-3981-110-3SRP	D-SUB 26 (1) 110Ω
AMX-3981-75-3DRP-F	BNC (8) 75 Ω
AMX-3981-75D-3SRP	DIN 1.0/2.3 (8) 75 Ω

The pinout of the D-SUB connector for both 110Ω rear panels is shown in this chart.

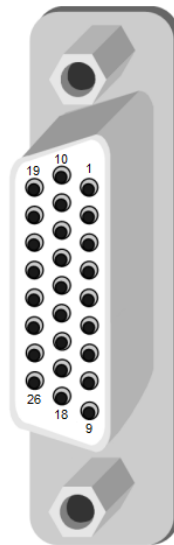

AMX-3981-110-3SRP AMX-3981-110-3DRP-F	Pin #
AES IN 1 (Hi)	1
AES IN 1 (Lo)	10
AES IN 2 (Hi)	2
AES IN 2 (Lo)	11
AES IN 3 (Hi)	3
AES IN 3 (Lo)	12
AES IN 4 (Hi)	4
AES IN 4 (Lo)	13
AES IN 5 (Hi)	5
AES IN 5 (Lo)	14
AES IN 6 (Hi)	6
AES IN 6 (Lo)	15
AES IN 7 (Hi)	7
AES IN 7 (Lo)	16
AES IN 8 (Hi)	8
AES IN 8 (Lo)	17
GND	9, 18-26

Fiber I/O – Fiber-optic inputs and outputs

Rear panels whose part number ends in –F incorporate a fiber optic interface. The interface consists of two parts:

- A socket on the rear panel into which an SFP interface module is plugged
- An SFP (Small Form-factor Pluggable) module into which the optical fibers are plugged, and which incorporates the optical/electrical interface

The optical fibers must be terminated in an LC connector.

See [ANNEX 2 – Installing the Optical Interface](#) for instructions on installing and removing the SFP interface module, and for plugging and unplugging the LC-terminated fibers.

The SFP modules supported by the AMX-3981 are:

SFP Modules	Description
SFP-RR-LC	Dual Rx module with LC connector
SFP-TT-S13S13-LC	Dual Tx module at 1310 nm with LC connector
SFP-RT-S13-LC	Single Rx and Tx transceiver module at 1310 nm with LC connector
SFP-R-LC	Single Rx module with LC connector
SFP-T-S13-LC	Single Tx module at 1310 nm with LC connector

GPI / RS-422 B / LTC – GPI I/O and Metadata I/O

GPI, RS-422 and LTC signals are carried on different connector types on the various rear panels available for the AMX-3981, to make most effective use of the available panel area.

➤ **AMX-3981-75D-3SRP and AMX-3981-110-3SRP**

For the two single width rears, all three signals are carried on an RJ-45 connector, with the pinout as shown in the table:

Note that in this configuration, only two GPIO are available, while the double-width rear panels carry three

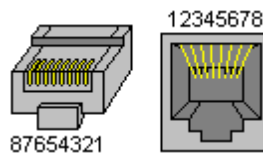

Function	Pin #
GPIO USER1	7
GPIO USER2	5
LTC	4
RS422-RX1-1	1
RS422-RX1-0	2
RS422-TX2-1	3
RS422-TX2-0	6
GND	8

➤ **AMX-3981-75-3DRP-F**

This rear panel carries three GPIO and RS-422 on an RJ45 connector and LTC on a separate BNC connector. The pinout of the RJ45 is as follows:

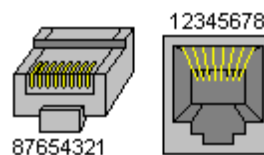

Function	Pin #
GPIO USER1	7
GPIO USER2	5
GPIO USER3	4
RS422-RX1-1	1
RS422-RX1-0	2
RS422-TX2-1	3
RS422-TX2-0	6
GND	8

➤ **AMX-3981-110-3DRP-F**

This rear panel carries three GPIO and RS-422 on a 15-pin D-SUB connector and LTC on a separate BNC connector. The pinout of the 15-pin D-SUB is as follows:

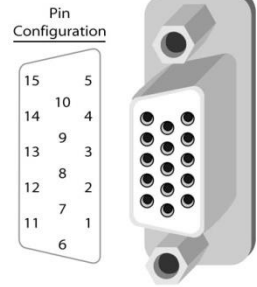

Function	Pin #
GPIO USER1	3
GPIO USER2	8
GPIO USER3	10
RS422-RX1-1	1
RS422-RX1-0	6
RS422-TX2-1	2
RS422-TX2-0	7
GND	5,11,12, 14,15
NC	4, 9, 13

3 User Interface

3.1 Control options

The AMX-3981 can be controlled in three different ways:

- The local control panel and its push-buttons can be used to move through a menu of parameters and to adjust parameter values (see section 4).
- Grass Valley’s iControl system can be used to access the card’s operating parameters from a remote computer, using a convenient graphical user interface (GUI) (see section 0).
- Grass Valley’s RCP-200 panel (check for availability).

3.2 Card-Edge Status LED

The status monitor LED is located on the front card-edge of the AMX-3981, and is visible through the front access door of the DENSITÉ frame. This multi-color LED indicates the status of the AMX-3981 by color, and by flashing/steady illumination.

The chart shows how the various error conditions that can be flagged on the AMX-3981 affect the LED status.

- If a cell is gray, the error condition cannot cause the LED to assume that status
- If more than one LED status is possible for a particular error condition, the status is configurable. See Section 5.17 for details.
- The factory default status is shown by a ✪

The LED will always show the most severe detected error status that it is configured to display, and in the chart error severity increases from left to right, with green representing no error/disabled, and flashing red the most severe error.

If the LED is Flashing Yellow, it means that the card is selected for local control using the Densité frame’s control panel. See Section 4 for details.

Error Condition	LED Status			
	Green	Yellow	Red	Flashing Red
Cooling Fan 1 error				✪
FPGA error				✪
Dataflash Error				✪
No Rear				✪
AES Receiver 1 error ⋮ AES receiver 8 error				✪
Reference missing			✪	
Reference mismatch			✪	
Test Mode		✪		
Carrier 1 detect error			✪	
AES 1 Presence error ⋮ AES 8 Presence error	✪			
Silence detected Channel 1 ⋮ Silence detected Channel 32	✪			

4 Local Control Using the Frame’s Control Panel

Push the SELECT button on the AMX-3981 card edge (see Section 1.4) to assign the local control panel to operate the AMX-3981.

- The STATUS LED on the AMX-3981 card edge flashes yellow.

Use the control panel buttons to navigate through the menu, as described below.

- The complete menu structure is shown in [ANNEX 1](#) to this document.

Two versions of the local control panel exist:

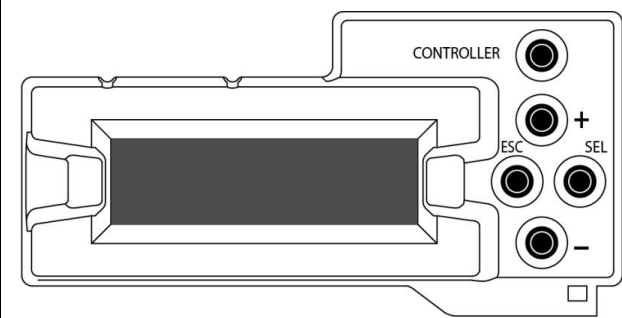
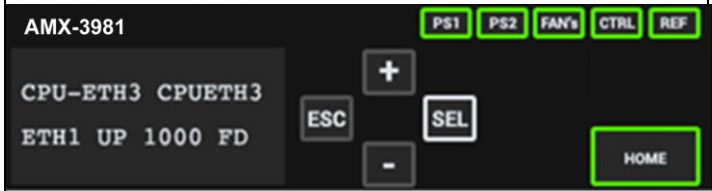
Panel type	Frame models	Appearance
Physical	Densité-2, Densité-3, Densité-3+FR1,	
Touch screen	Densité 3+FR4, GV Node	

The local control panel is fastened to the front of the frame’s controller card.

- The physical panel is accessed by opening the front door of the frame.
- The touch screen panel is accessed through an aperture in the frame door.

The panel incorporates a display capable of displaying two lines of text, each 16 characters in length, and four pushbuttons. The functionality of the pushbuttons is as follows:

[+] [-] Used for menu navigation and value modification

[SELECT] Gives access to the next menu level. When a parameter value is shown, pushing this button once enables modification of the value using the [+] and [-] buttons; a second push confirms the new value

[ESC] Cancels the effect of parameter value changes that have not been confirmed; pushing [ESC] causes the parameter to revert to its former value.

Pushing [ESC] moves the user back up to the previous menu level. At the main menu, [ESC] does *not* exit the menu system. To exit, re-push the [SELECT] button for the card being controlled.

- Notes:
1. If you do not touch any buttons on the local control panel, the controller will revert to its normal standby mode after 30 seconds.
 2. If you changed a parameter from the control menu, but have not applied your change (you did not touch the SEL button on the control panel), once the 30-second timeout has occurred, the parameters will be confirmed as if you had touched the SEL button

5 Remote Control Using iControl

The operation of the AMX-3981 may be controlled using Grass Valley's iControl system.

- This manual describes the control panels associated with the AMX-3981 and their use.
- Please consult the iControl User's Guide for information about setting up and operating iControl.

In iControl Navigator or iControl Websites, double-click on the AMX-3981 icon to open the control panel.

5.1 The iControl Graphic Interface Window

The basic window structure for the AMX-3981 is shown in figure 5.1. The window identification line gives the card type (AMX-3981) and the slot number where the card is installed in its Densité frame.

There are four main sections in the window itself, identified in figure 5.1:

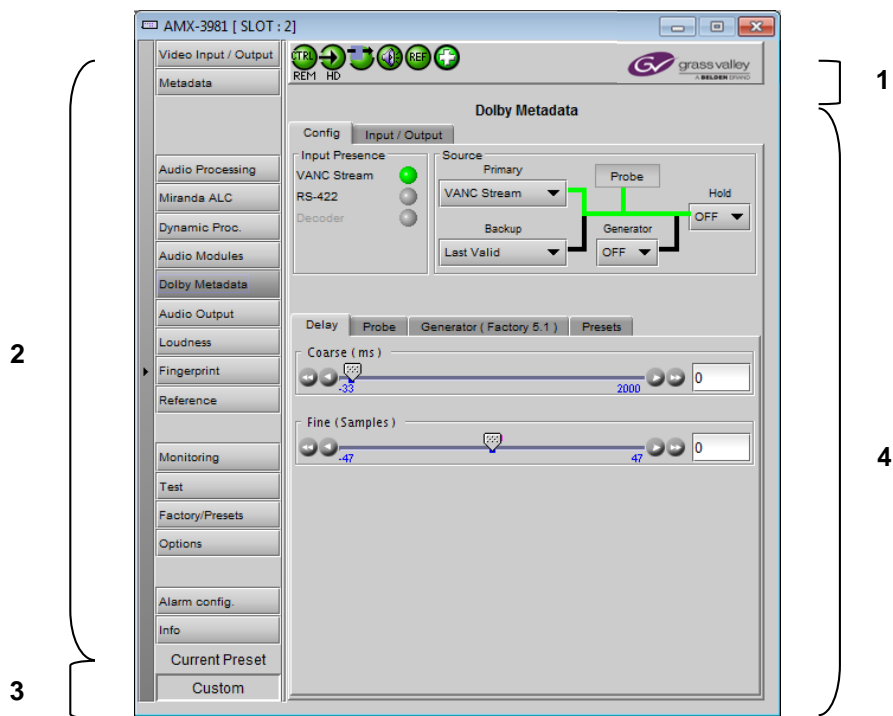

Figure 5.1 AMX-3981 iControl graphic interface window

Section 1. The top section displays six icons on the left. These icons report different statuses such as card communication status, input signal and reference signal format and statuses. In some instances, they relate to conditions defined through parameters settings.



Icon # 1 2 3 4 5 6

Move the mouse over an icon and a status message appears below the icon providing additional information.





If there is an error, the error status message appears in the message area without mouse-over.



- If there are multiple errors, the error messages cycle so all can be seen
- The icon whose status or error message is shown is highlighted with a mauve background

The table below describes the various status icons that can appear, and how they are to be interpreted.



- In cases where there is more than one possible interpretation, read the error message in the iControl window to see which applies.

Table –iControl Status Icon interpretation



Icon #1 – Manual Card Configuration	
 (green)	Remote card control activated. The iControl interface can be used to operate the card
 (yellow)	Local card control active, The card is being controlled using the Densité frame control panel, as described in section 4. Any changes made using the iControl interface will have no effect on the card.
Icon #2 – Input status	
 (green)	Signal detected and valid. <ul style="list-style-type: none"> • Beneath the icon, the format will be indicated as 3G, HD or SD, and the specific format details will be listed if the cursor is moved over the icon.
 (red)	Signal absent No rear Reference mismatch Video/TRS error
Icon #3 – Operation Mode	
 (green)	Operation mode: process – normal processing of the input signal

 (yellow)	Operation mode: TEST – color bar and audio test tones enabled (see Sect. 5.14)
 (yellow)	Operation mode: Manual Freeze ON (see Sect. 5.2 – Freeze tab)



Icon #4 – Audio Status

 (green)	Audio OK
 (yellow)	Yellow alarm condition detected on 1 or more channels
 (red)	Red alarm condition detected on 1 or more channels

Icon #5 – Reference

 (green)	Reference OK. Mouse over to see the source of the reference, and its format, e.g. External, NTSC
 (red)	Reference missing. The reference is required for correct deglitcher operation.
 (gray)	Reference absent

Icon #6 – Operation Mode

 (green)	Hardware OK
 (red)	Hardware Health Monitoring (Fan1, Fan2, Hardware fault detected) If this icon appears red, return the card to Grass Valley and specify the error code.

Section 2. The left portion of the window contains all the parameter groups, which become highlighted when they are selected; the main panel (4) then displays the group’s set of parameters. Each of the groups is described in detail below.

Section 3. The lower left corner of the window identifies the Preset currently in use or “Custom” if none is applicable.

Section 4. The main panel contains all the parameters specific to the group selected. It may contain several tabs to help manage the different parameters.

Each of the panels associated with the groups accessed from the buttons in Section 2, and shown in Section 4, is described individually in the following sections.

5.2 Video Input/Output panel

This panel allows input selection, control of the deglitcher and freeze functions, and timing delay.

Input Select: use the pulldown list to select between the copper input (BNC) and the fiber optic input (if available)

- The list will only be active if an Optic Fiber module is installed in the rear panel. Otherwise it will be grey and locked as BNC



Figure 5.2 Video Input/Output panel

5.2.1 Fiber Input/Output tab

This tab will only appear when a fiber optic module is installed in the rear panel. The panel will be appropriate to the type of module installed.

- The “Detected” data box shows the type of module that the AMX-3981 has identified.
- The controls that appear allow the inputs and outputs on the fiber module to be configured.

Options: OFF or ON

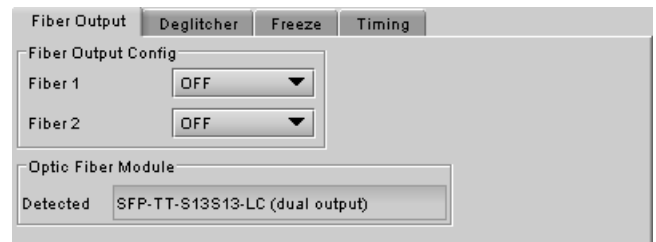

Figure 5.3 Fiber Output tab

5.2.2 Deglitcher tab

When the Deglitcher is active, the card supports a hot-switch between two signals without producing a freeze on the frame buffer, and without producing artifacts on the output.

- In order to enable the deglitcher, the URS signal must be selected as the reference in the Reference panel (see section 0)

Deglitcher: select OFF or ON from the pulldown

For this mode to function correctly, the following requirements must be met:

- The two inputs must be synchronized to the reference
- They must be phased within one line of each other
- They must be phased to within +/- ½ line of the HREF of the reference signal

The offset from the VREF can be variable, but a distance of greater than 10 lines could create an artifact in the active video. If the two signals are more than 1 line apart, we will see a vertical jump at the moment of switching that is proportional to the number of vertical lines of offset between the two signals. This will last for only one frame. There may also be problems in the transition when in the AFD automatic or forced mode.

When a reference is present and the deglitcher is active, the card reports the difference in timing between the input and the reference when the transition occurs.

- If the reference is missing when the deglitcher is activated, the Input timing to reference box will indicate “Missing reference” in red, and the reference status icon at the top of the iControl window will turn red and show the message “Reference missing”.
- If the deglitcher is OFF, the reference status icon will be grey, and its message will read “Reference absent”

To perform a glitch-free switch between two sources, they must be in the same clean switch region. A clean switch region is contained within ± ½ line about an H=0 point in the reference signal, as shown by the dotted lines in the figure. There is a clean switch region centered on every H interval. As you can see, vertical alignment with the reference is not important for the deglitcher to operate properly.

Referring to the figure on the right, you may switch between signals A, B or C, without any glitch, and also between signals D ↔ E and signals F ↔ G. Any other transition, like A ↔ D, will cause a vertical image shift for one frame.

To determine whether a clean hot switch is possible, you need to determine whether the two input signals lie in the same clean switch region. There are two ways to measure the position of the signals with respect to the reference:

- Use the deglitcher tab in iControl (Input→Deglitcher)
- Use the controller menu in Annex 1 (video→timing→in timing to ref).

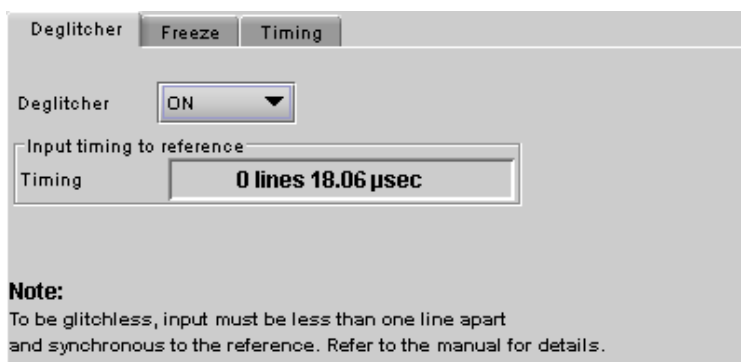
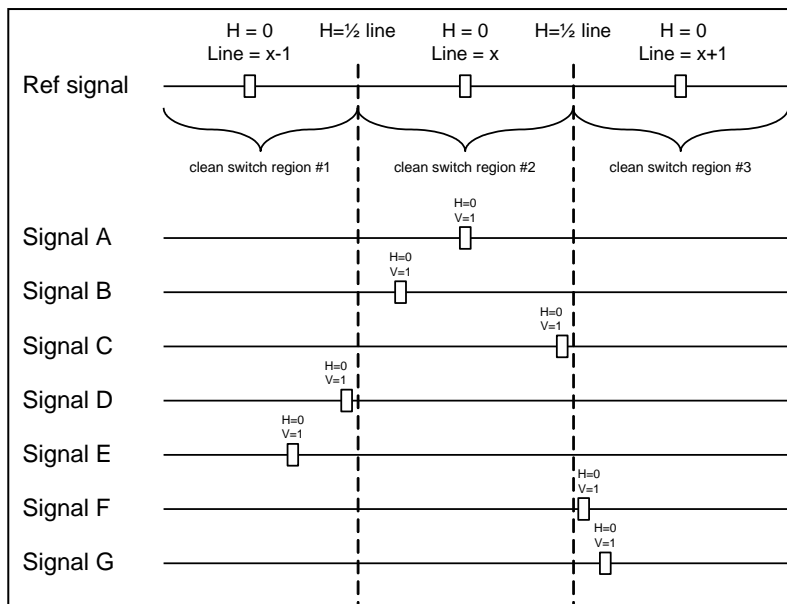

Figure 5.4 Video Input/Output – Deglitcher tab



When the deglitcher mode is on, each of these sources will display the alignment offset between the reference signal and the input signal. Knowing the offset for both input signals, you can determine if they are in the same clean switch region. If so, any hot-switch between those two signals will be glitchless.

To determine the limits of a clean switch region, you must know the input's line length in μs . The first region is delimited by $+\frac{1}{2}$ line and $-\frac{1}{2}$ line of the reference. For example, with an SD (525) signal the line length is $63.5 \mu\text{s}$ and so the first region lies between $-31.76 \mu\text{s}$ and $31.76 \mu\text{s}$. Other regions can be found by adding or removing a multiple of line length to the two boundaries.

Example: for an SD (525) input signal, we have these clean switch regions:

-1 line and $-31.76 \mu\text{s}$ to 0 line and $-31.76 \mu\text{s}$

0 line and $-31.76 \mu\text{s}$ to 0 line and $31.76 \mu\text{s}$

0 line and $31.76 \mu\text{s}$ to 1 line and $31.76 \mu\text{s}$

etc.

Practical examples:

Example 1: we have two SD (525) sources, one that indicates an offset of $-25 \mu\text{s}$ with respect to the reference (A) and the other an offset of $-35 \mu\text{s}$ (B). We know that a clean switch region limit is present at $-\frac{1}{2}$ line, which corresponds to $-31.76 \mu\text{s}$. We can now determine that this switch will not be clean, because the two sources are on opposite sides of the limit, and are therefore not in the same clean switch region.

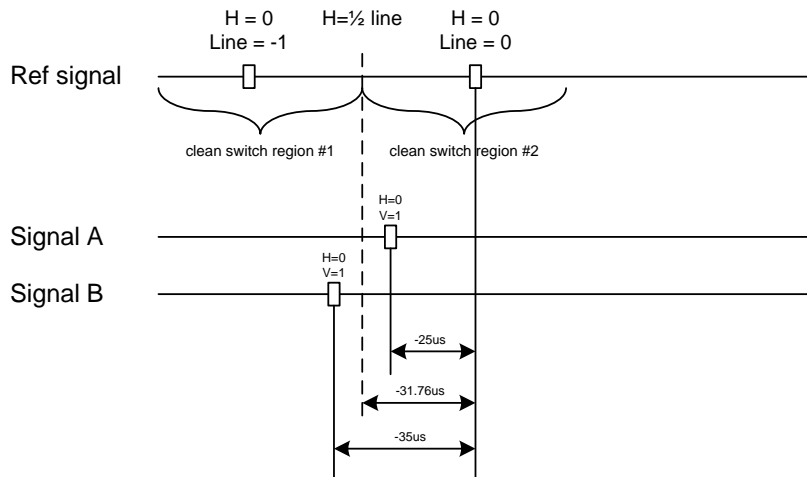

Example 2: We have two SD (525) sources, one that indicates an offset of $50 \mu\text{s}$ with respect to the reference (A) and the other an offset of $40 \mu\text{s}$ (B). We know that a clean switch region limit is present at $+\frac{1}{2}$ line and another one at $\frac{1}{2}$ line plus one line. These correspond to $31.76 \mu\text{s}$ and $95.28 \mu\text{s}$. We can now determine that this switch will be clean, because the two sources are inside the same clean switch region.

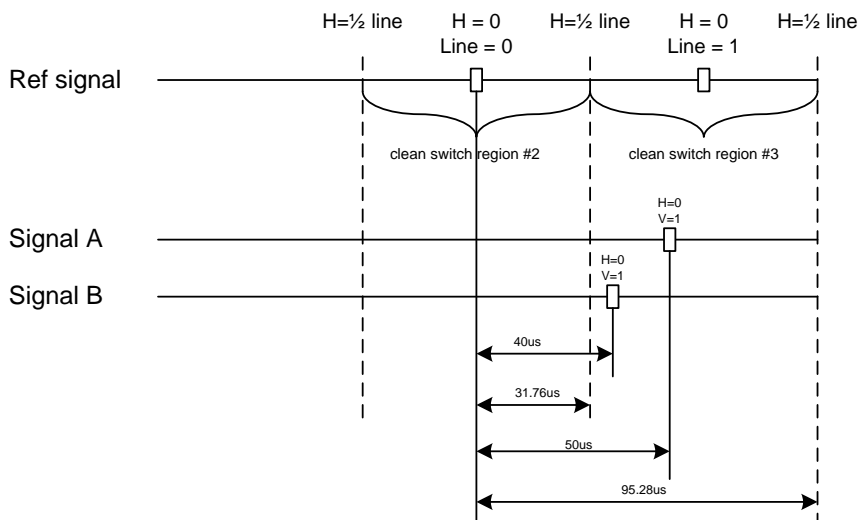

5.2.3 Freeze tab

Freeze type: This is a pull-down menu with four options – FIELD 1, FIELD 2, FRAME and BLACK. It determines the manner in which the AMX-3981 responds to a manual freeze, a video input switch (“hotswitch” as defined by SMPTE recommended practice RP-168, revised January 2002), a loss of input signal or other input errors. The four possible options yield the following results:

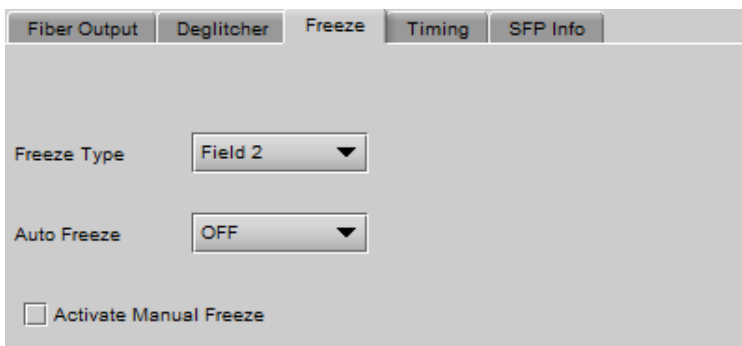

Figure 5.5 Video Input/Output – Freeze tab

Freeze Type	Auto Freeze Mode	Manual Freeze Mode
• Field 1	Freeze to last valid FIELD	Freeze to last valid FIELD 1
• Field 2		Freeze to last valid FIELD 2
• Frame		Freeze to last valid FRAME
• Black	Freeze to BLACK	

Auto Freeze: This pull-down (ON/OFF) enables or disables the auto freeze function. In Auto Freeze mode, a reference must be present to ensure a glitchless output when a freeze is activated. There are only two freeze possibilities in Auto mode: freeze to last valid Field or freeze to black. When Auto Freeze mode is disabled, the content of the active picture will reflect whatever garbage is present at the input but, if a reference is present, the output synchronization will be maintained to avoid unlocking downstream equipment.

Activate Manual Freeze: Select this checkbox to immediately freeze the output according to the selected Freeze Type mode.

Note: The manual freeze setting is saved in the non-volatile memory of the card. If the manual freeze is activated and the power is cycled, the card will start in freeze mode at the next power-up and the output will be invalid. Just turn off the manual freeze to restore the output.

In all cases, audio will be muted when there is an input error. See the audio section for more information.

5.2.4 Timing tab

The Timing tab provides access to timing adjustments which affect the signal outputs. There are three slider controls, each with a data reporting box which shows the current value, and into which values can be typed directly. The total delay is reported at the top of the window.

Vertical (lines): With this adjustment, a value ranging from -16 to +16 lines compared to the reference or the processing delay may be set. This adjustment can be used in conjunction with the horizontal timing adjustment.

Horizontal (µsec): With this adjustment, a value ranging from zero to the equivalent of 1 horizontal line in the current operating format compared to the reference or the frame boundary may be set.

Frame Delay (Frames): This parameter affects the overall processing delay of the card. It adds supplemental frame delay to the current processing delay. This parameter will add a delay ranging from 1 to 15 interlaced frames (steps of 33 ms in 59.94 Hz and 40 ms in 50 Hz) to the current processing delay. Without a reference, the normal processing delay is 1 frame. You can extend this delay up to 16 frames using this slider. With a reference, up to 15 frames can be added to the frame sync delay which depends on the timings between the input and the reference.

Note that, in order to compensate for the processing delay of a Dolby E and Dolby Digital decoder or a Dolby E encoder installed on the AMX-3981 card, the frame delay must be set to at least one (1) frame. On the other hand, if a Dolby Digital and Dolby Digital Plus encoder is installed, the frame delay must be set to at least seven (7) frames for 59.94 Hz formats and at least six (6) frames for 50 Hz formats.

Minimum Delay Mode

The minimum delay mode minimizes the processing delay of the video. The audio processing delay varies depending on the presence of options. The following charts show the processing delay of audio and video for different video formats and options.

Video Processing Delay:

- SD: 20 µs
- HD: 7.5 µs
- 3G – Level A: 3.8 µs
- 3G – Level B: 4 Lines + 4 µs

Audio Processing delay:

	<u>ALC</u>	<u>DP</u>	<u>Delay</u>	<u>Delay using AES In</u>
3G/HD/SD	No	No	2 ms	4 ms
3G/HD/SD	No	Yes	3 ms	5 ms
3G/HD/SD	Yes	No	3 ms	5 ms
3G/HD/SD	Yes	Yes	4 ms	6 ms

Note that using the AES inputs adds 2 ms to the delay, as shown in the table

Note: When minimum delay is active the following features will be disabled: AFD auto mode, frame buffer, A/V deglitcher, freeze functions and DOLBY E alignment.

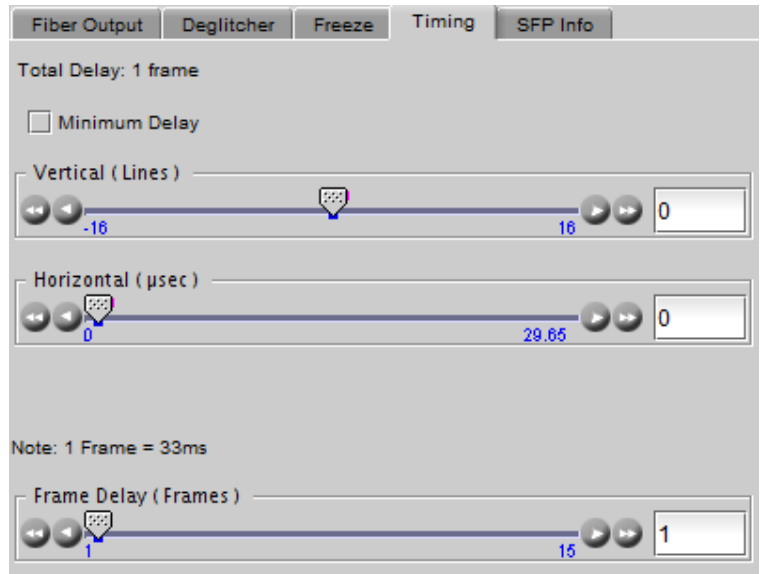
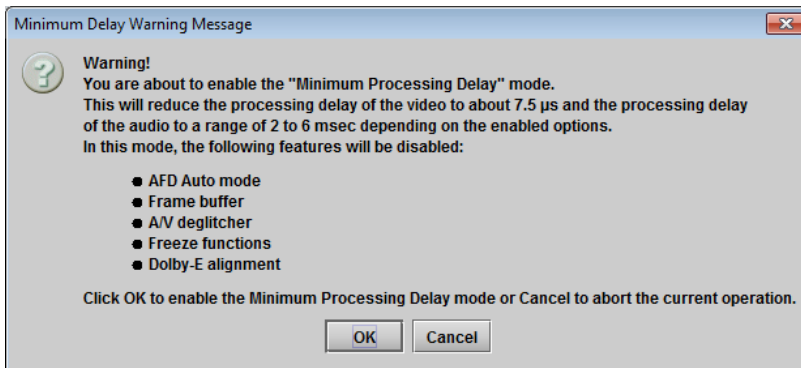

Figure 5.6 Video Input/Output – Timing tab

Enable the *Minimum Delay* checkbox to place the AMX-3981 in this mode. A pop-up warning will appear, explaining the implications of using this mode:



5.2.5 SFP Info tab

When an SFP module is detected in the rear panel socket of this AMX-3981, this tab shows identifying information:

- Type
- Part Number
- Serial Number
- Date Code

Additionally, some parameters are measured and their values displayed here:

- Temperature
- Voltage (V)
- Optical Power (dBm)
- Wavelength (nm)

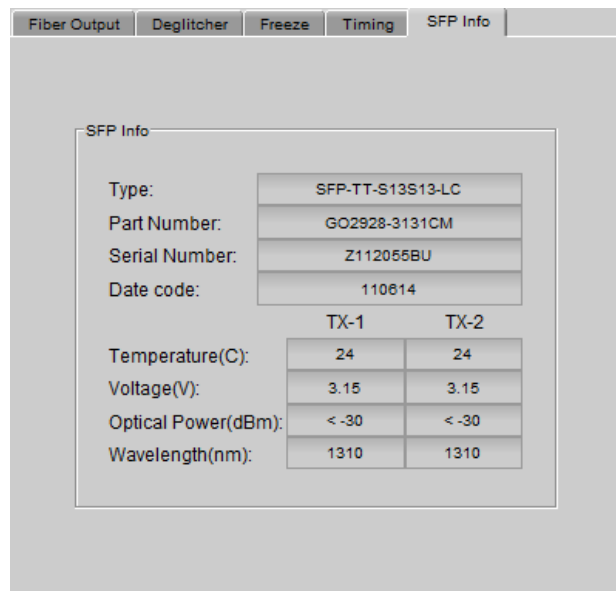

Figure 5.7 Video Input/Output – SFP Info tab

5.3 Metadata panel

This panel contains three tabs that give access to metadata processing on the AMX-3981 card:

- LTC
- GPI
- AFD

5.3.1 LTC tab

This tab controls LTC timecode embedding into the output SDI data stream.

The Status icons indicate the presence of different time code formats:

- LTC input (on the rear panel)
- DVITC (SD) embedded in the SDI input
- ATC-LTC (3G/HD) embedded in the SDI input
- ATC-VITC (3G/HD) embedded in the SDI input

The LTC Timecode Embedding section provides resources to configure the embedding process.

Delay: [0, 1, 2, 3 frames]

SD Insertion Line: Select the line in which to embed LTC in the SD-SDI output signal. Available only when SD is detected at the input.

[10-20 for 525; 7-22 for 625]

SD Duplicate: Select the line in which to embed a duplicate LTC in the SD-SDI output signal. Available only when SD is detected at the input.

Insertion: In the case of 3H/HD signals, select OFF to disable insertion and pass incoming signals through unchanged, or BOTH to embed both ATC-VITC and ATC-LTC from the LTC input on the rear panel into the output.

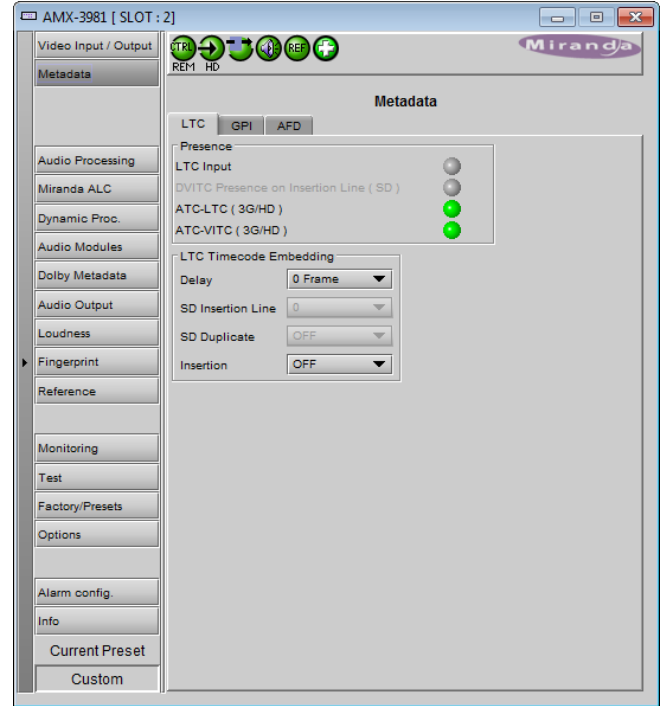

Figure 5.8 Metadata Panel – LTC tab

5.3.2 GPI tab

The AMX-3981 can both de-embed and embed GPI data from/to timecode. As well, GPI inputs can be used to load user presets on the AMX-3981 card, or reset loudness measurements.

GPI status: the icons show the status of the three GPI inputs on the rear panel.

Timecode Presence: Shows the time codes that are available for embedding / de-embedding the GPI data. Embed and De-embed are shown separately for SD timecode, since they can be on different line numbers.

Load Presets: Use the pulldown lists to select what will occur when each of the three rear-panel GPI inputs is activated and released. Options are:

- Do nothing
- Load one of the five User Presets
- Reset the loudness measurement (see *RESET* on page 56)

GPI Embedding / De-embedding: set up the embedding or de-embedding of GPI data in the output and input data streams. For each of the three GPIs:



Figure 5.9 Metadata Panel - GPI tab

Mode: use the pulldown list to select the operating mode for this GPI:

- OFF – the GPI is passed through untouched
- De-embed – a pre-defined user binary group bit from timecode within the incoming signal is de-embedded and appears on the rear-panel GPI port
 - When De-embed is selected, use the Bit pulldown list to select which of the user binary group bits (1-16) will be extracted to this GPI.
- Embed – the data placed on the rear-panel GPI port is embedded to a pre-defined user binary group bit within timecode in the outgoing data stream.
 - When Embed is selected, use the Bit pulldown list to set which of the user binary group bits (1-16) will be used to carry the GPI data.

GPI Embedding Config

SD Insertion Line (SD signals only): Select the line into which the GPI data will be embedded [10-20 for 525 and 7-22 for 625] provided DVITC time code is present.

Insertion (3G/HD signals only): select the ATC format [ATC-VITC, ATC-LTC or BOTH] into which the GPI data will be embedded, provided the selected ATC format is present

If the source has no time code, a fixed time code of 00:00:00:00 will be generated in the appropriate format – DVITC (SD), ATC-VITC or ATC-LTC (HD) – to carry the GPI and ensure that it is embedded.

Note that to accommodate on-card processing requirements, the GPI should be asserted no later than 1 ms before the switch line in order to ensure that it is embedded in the next field.

GPI De-embedding Config

SD Extract Line (SD signals only): Select the line from which the GPI data will be de-embedded [10-20 for 525, 7-22 for 625] provided DVITC timecode is present.

GPI Source Type (3G/HD signals only): select the ATC format from which GPI data will be de-embedded [ATC-VITC, ATC-LTC] provided the selected ATC format is present.

GPI Latch Mode: When no valid time code with embedded GPI data has been detected, the user has the option of releasing the GPI outputs (Latch mode OFF), or holding the last valid de-embedded values (Latch Mode ON).

5.3.3 AFD tab

The Active Format Descriptor (AFD) flag is used to identify the aspect ratio and protected areas of a video signal. The AMX-3981 manages the transfer of the AFD flag between its input and output, but does not use the AFD flag to perform any picture manipulation. The AFD flag is implemented differently in HD and SD:

- In HD, the AFD flag (SMPTE 2016) is sent as an ancillary packet, normally found on line 11 in the vertical ancillary space.
- In SD, the AFD flag is sent as a Video Line Index (VLI) signal (RP 186), as a Wide Screen Signaling (WSS) signal (ITU-R BT.1119-2) for 625 only, and as an AFD packet (SMPTE 2016).

Note: The term AFD is used to represent all three types of flags – SMPTE 2016 ancillary packet, VLI, and WSS.

The two graphics at the top of the panel show the input and output AFDs and indicate the status (e.g. detected, inserted). See [ANNEX 5 – AFD Flags](#) on page 108 for information about AFD flags and terminology.

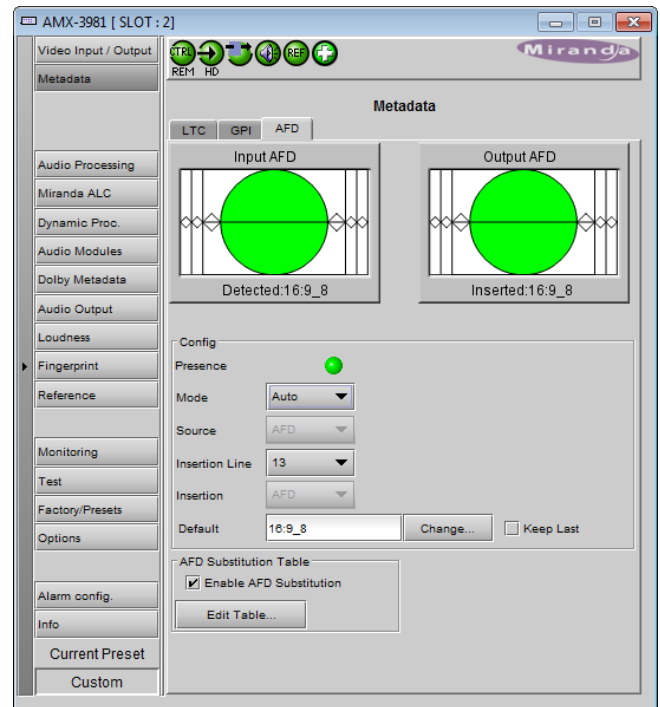

Figure 5.10 Metadata - AFD tab

5.3.3.1 Config section

Presence: The status indicator turns Green when AFD is detected on the input signal. On an SD input, the status indicator will indicate the presence of AFD flags carried as selected by the Source pulldown below, i.e. AFD, VLI or WSS (for 625 sources only)

Mode: use the pulldown list to specify how AFD information will be handled. Available choices are:

- Pass – pass the incoming AFD flag through without change
- Insert – insert the ‘Forced’ AFD flag into the output, overwriting any incoming flags
- Auto – if incoming flags are detected, pass them through, otherwise, insert the “Default” flag
- Blank – ensure that no AFD flags are embedded in the output stream.

Source: Selects the source of AFD information – options are AFD (SMPTE 2016), VLI (SD only) or WSS (for 625 sources only).

Insertion Line: The Insertion line is used to select on which line in the VANC the AFD packet (SMPTE 2016) will be inserted. It is not necessary to specify the detection line since the card will automatically detect the incoming packet.

Insertion: The Insertion pull-down menu is used to enable or disable the insertion of AFD on the output. This feature makes possible AFD conversion (SMPTE 2016 to VLI, VLI to WSS, VLI to SMPTE 2016, etc ...) by allowing the user to select the type of AFD flag to insert regardless of the programmed AFD source type:

- During HD operation, the Ancillary Aspect Ratio packet (SMPTE 2016) may be inserted. There is no AFD conversion during HD.
- During SD operation, the Ancillary Aspect Ratio packet (SMPTE 2016), VLI, or WSS for 625 may be inserted

Default/Forced: this text box is labeled according to the mode selected in the Mode pulldown above

- In AUTO mode, it is labeled DEFAULT and shows the current default AFD code to be used if no valid AFD code is detected at the input.

- In INSERT mode, it is labeled FORCED, and shows the code that is forced onto the output regardless of the actual input code or if one is present

Change: Click the Change button to open the *Select AFD* panel showing the available AFD codes that could be used as the default code/forced AFD flag during AUTO/INSERT modes. Click on one to select it, then click *Apply* or *OK* at the bottom of the panel.

Keep Last: Select this checkbox to use the last AFD code detected at the input as the default code to be used in the *Auto* mode when no AFD flag is detected. This box is disabled in the *Insert* mode.

5.3.3.2 AFD Substitution Table

In the Auto mode, it is possible to set up a systematic AFD substitution scheme, where incoming AFD flags can always be replaced by different flags, according to the AFD Substitution table.

- Select the Enable AFD Substitution checkbox to use this feature. The checkbox is only available in Auto mode

Click the *Edit Table...* button to open the AFD Substitution Table

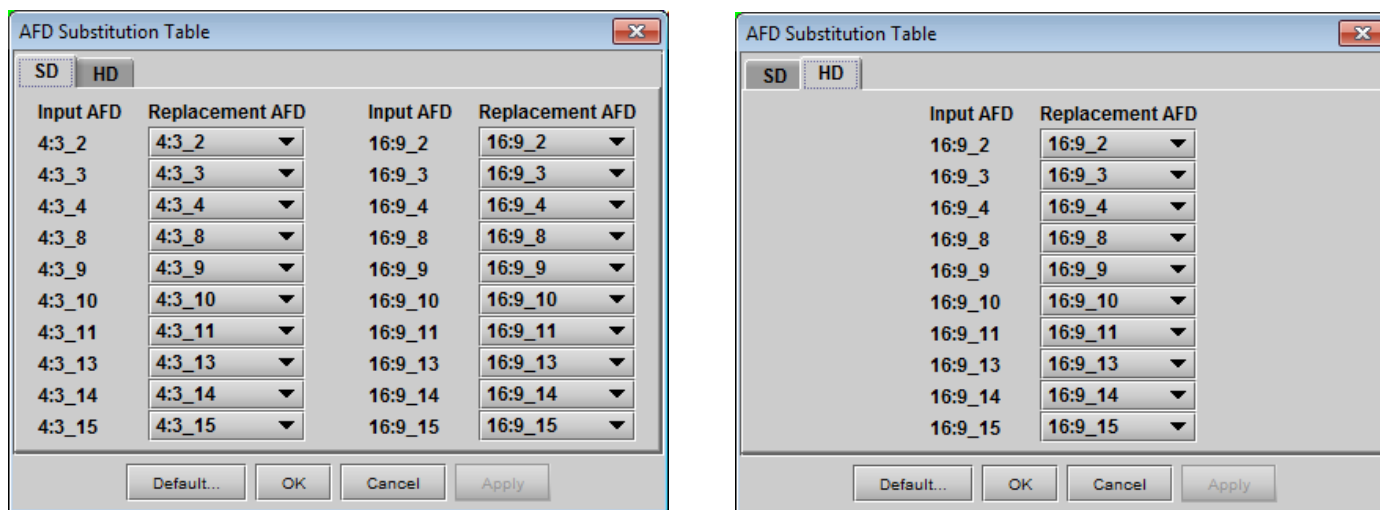
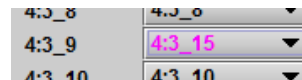

Figure 5.11 AFD Substitution table

- The table has two tabs, one for SD inputs, and one for HD inputs.
- The table in each tab lists all possible Input AFD flags for that format, and beside each is a *Replacement AFD* pulldown list that also lists all possible AFD flags.
- If the Replacement AFD does not match the Input AFD, the Replacement AFD name is colored, so that it is immediately obvious which AFDs will be substituted.



Note: AFD substitution is ignored when no source flag is detected at the input. In this case, the Default flag is used.

5.3.3.3 Error and Warning Messages (SD only)

During SD operation, situations may arise when a conflict has occurred or may occur due to the enabling of certain metadata parameters such as time code insertion, SMPTE 2016/VLI insertion, or Dolby Metadata insertion.

- A warning message will appear at the bottom of the Metadata / AFD panel.
- See for an example.

Here is a list of all possible messages that may be displayed and a description of the error or potential conflict.

“Dolby Metadata/VLI line insertion conflict. Refer to the user manual.” [Error in red]

This error occurs when the AMX-3981 has been programmed to generate Dolby Metadata and VLI on the same line. The VLI signal is placed on line 14 for 525 and line 11 for 625. Make sure to select a different line number for Dolby Metadata insertion.

“AFD insertion may overwrite incoming TC on insertion line. Refer to the user manual.” [Warning in blue]

Incoming DVITC time code may unknowingly be replaced by the insertion of SMPTE 2016 AFD flag. In order to avoid any problems, make sure the line number of any incoming time code is known.

“Dolby Metadata insertion may overwrite incoming TC/VLI on insertion line. Refer to the user manual.” [Warning in blue]

Incoming DVITC time code or VLI signal may unknowingly be corrupted by the insertion of Dolby Metadata. In order to avoid any problems, make sure the line number of any incoming time code is known. If Dolby Metadata is inserted on line 14 in 525 or line 11 in 625, make sure no time code or VLI is present in the input video signal.

“Dolby Metadata insertion may overwrite incoming TC on insertion line. Refer to the user manual.” [Warning in blue]

Incoming DVITC time code may unknowingly be corrupted by the insertion of Dolby Metadata. In order to avoid any problems, make sure the line number of any incoming time code is known.

“Dolby Metadata/AFD insertion may overwrite incoming TC on insertion line. Refer to the user manual.” [Warning in blue]

Incoming DVITC time code may unknowingly be replaced by the insertion of Dolby Metadata or the SMPTE 2016 AFD flag. In order to avoid any problems, make sure the line number of any incoming time code is known.

“VLI insertion may overwrite incoming Dolby Metadata on insertion line. Refer to the user manual.” [Warning in blue]

Incoming Dolby Metadata may unknowingly be corrupted by the insertion of the VLI flag. In order to avoid any problems, make sure no Dolby Metadata is present on line 14 in 525 or line 11 in 625 when VLI is inserted.

5.4 Audio Processing panel

The Audio Processing panel provides full audio processing and delay parameters for up to 32 channels. The first 16 channels come from the embedded input channels. The second set of 16 channels comes from the output channels of the following modules:

- Dolby E and Dolby Digital decoder module(s) – see note
- Linear Acoustic’s upMAX™ module(s)
- Downmix

Note – when the Dolby E or Dolby Digital and Dolby Digital Plus encoder is installed, some audio processing channels will not be available because they are used in the Dolby encoder module. In that case, an extra tab will appear in this panel to advise the user of the situation.

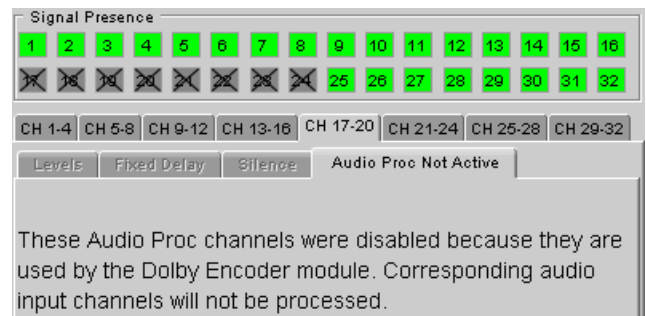

Figure 5.12 Audio proc warning for Dolby encoders

The 32 processed audio channels can be assigned later to the Dolby E or Dolby Digital and Dolby Digital Plus encoder modules, the 3G/HD output embedder, the SD output embedder, or the discrete AES outputs. To use the “Audio Processing” functionality, you must enable the audio option.

You can configure the audio processor differently for an SD input than for a 3G/HD input. The card will remember the different parameters and will load them automatically without user intervention based on whether the video input is SD or 3G/HD. Ensure the card has a video signal of the desired format before changing the configuration.

Group Detected section

Status indicators turn green when audio groups 1, 2, 3 or 4 are detected in the incoming signal. The Group Detected warning color can be configured by the user in the Alarm Config panel (Sect. 5.17)

Discrete AES detected section: Status indicators turn green when an AES signal is detected on the indicated rear panel AES input.

Signal Presence section

Signal presence indicators monitor the audio channel presence and are related to the Silence parameters defined in the Ch XX/Silence tab (see details below): the indicator is green when an active signal is present and configurable when a silence is detected according to the “no signal” threshold and the channel detection warning. The Signal Presence warning color can be configured by the user in the Alarm Config panel (Sect. 5.17)

Under the *Audio Proc* tab are grouped controls for several aspects of the AMX-3981’s audio processing:

- levels
- delay
- silence detection

All of these parameters are adjusted individually for each channel, and channels are accessed in groups of four via the first row of tabs in the panel. Below these tabs are the three tabs that access the parameters themselves.

In addition, control over Downmix is provided, and the status of all audio signals is monitored, under the appropriate tabs.

5.4.1 Audio Proc – Levels tab

Grouped by pairs of channels, each channel has the following controls:

Level (slider and input box): Sets the audio gain from -96 to 12 dB in 0.5 dB steps. For non-PCM audio, the level value is overridden to 0 dB.

Mute (speaker button): Mutes the selected audio channel

Phase Invert: When checked, inverts the selected audio channel phase.

Lock: “Locks” both channel sliders together for levels, so that moving one slider moves the other one as well.

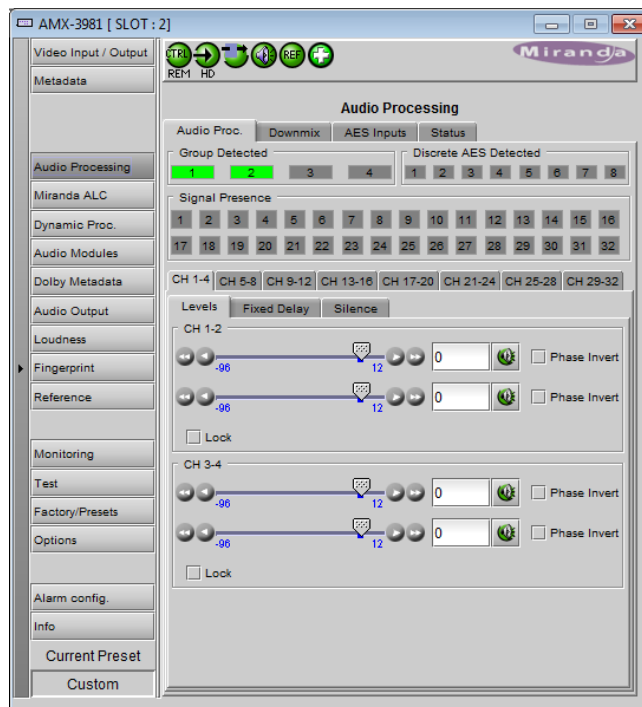

Figure 5.13 Audio Processing - Channels - Levels

5.4.2 Audio Proc – Fixed Delay tab

Fixed Delay sub-tab: although the AMX-3981 automatically matches audio and video throughput timing, provision is made for the user to insert an audio delay offset from the nominal value, in order to deal with problems such as lip-sync errors and audio phase alignment in the incoming feed. For each channel, two sliders allow the delay to be adjusted.

- *Coarse* – adjusts the delay in milliseconds, over a range of values that depends on the Reference and the Frame Delay set on the timing tab in the Video Input/Output panel (see page 25), as follows:

With Reference:

Additional Frame Delay	Adjustment Range (59.94 Hz)	Adjustment Range (50 Hz)
0	0 to 2000 ms	0 to 2000 ms
1	-33 to 2000 ms	-40 to 2000 ms
2	-66 to 2000 ms	-80 to 2000 ms
3	-99 to 2000 ms	-120 to 2000 ms
...
15	-500 to 2000 ms	-600 to 2000 ms

Without Reference:

Additional Frame Delay	Adjustment Range (59.94 Hz)	Adjustment Range (50 Hz)
1	-12 to 2000 ms	-19 to 2000 ms
2	-45 to 2000 ms	-59 to 2000 ms
3	-78 to 2000 ms	-99 to 2000 ms
...
15	-479 to 2000 ms	-579 to 2000 ms

- *Fine* – adjusts the delay in audio sample increments, from -100 to +100 samples.

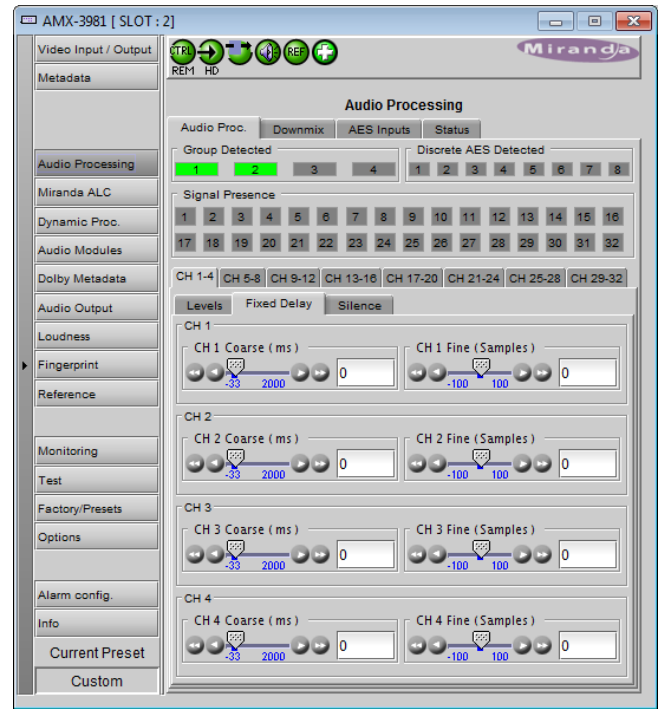

Figure 5.14 Audio Processing – Channels - Fixed delay

5.4.3 Audio Proc – Silence tab

This tab sets the card's behavior in the event of a loss or absence of audio signal. The Signal Presence indicators are then triggered according to these settings:

Silence Detect: select which audio channels to monitor for audio silences by checking their boxes. This enables the signal presence indicators to change color when there is no signal present which activates the audio silence alarm. Otherwise, when checkboxes are not checked, the signal presence indicator turns grey and the audio silence alarm is not activated

Threshold: Signal absence is declared when the signal level is lower than the signal threshold for a duration longer than the No Signal Delay. The threshold can be set to **-72, -66, -60, -54, -48 dBFS**. The default value is **-60 dBFS**.

No Signal Delay: The period for which signal must be continuously absent before an alarm can be triggered can be adjusted from 3 to 255 seconds in preset steps: 3, 5, 7, 10, 15, 20, 30, 40, 50, 60, 90, 120, 180, 210, 240, 255 sec. The default value is set to 15 seconds.

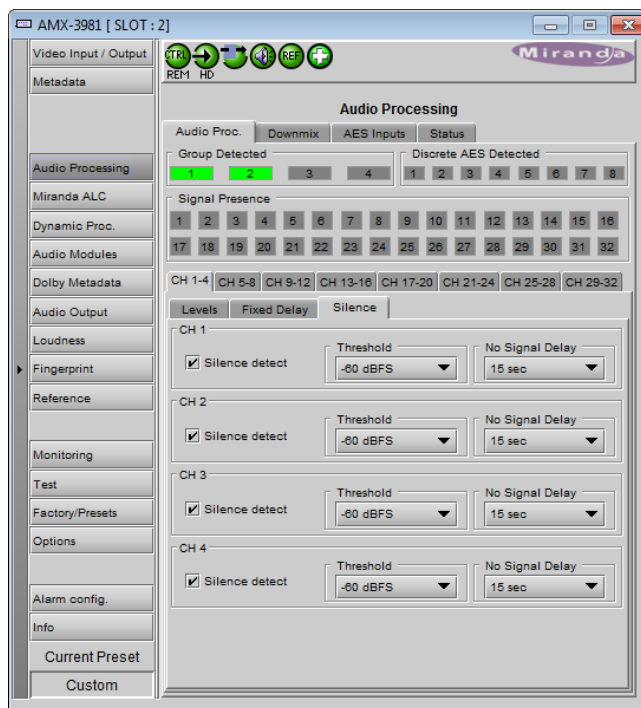

Figure 5.15 Audio Processing - Channels – Silence

5.4.4 Downmix

This tab provides resources to control the downmix of a “5.1 channel” surround-sound audio signal into an LtRt or LoRo stereo pair. The 5.1 terminology refers to six discrete audio channels, with the low frequency effect (LFE) channel of limited bandwidth designated as the “.1” channel. The downmix can be done using any of the 32 audio channels processed by the audio processor using the Input Channels controls in the interface.

Input Channels: Use the 6 pulldowns to select the source channels for the downmix process.

Downmix:

Operating Mode: Use the pulldown list to select the downmix operating mode:

- OFF: Downmix is disabled. Output channels pass through unchanged.
- Manual: Downmix follows the downmix parameters manually configured by the user.
- Follow Metadata: Downmix follows the downmix parameters of the Metadata.

Level Normalization: use the pulldown to select the type of normalization to be applied on the downmix output level.

- OFF: Downmix output level is not normalized. Clipping may occur depending on the input channel levels and the selected mix levels.
- Level A: Downmix output level is normalized based on the applied mix levels to provide a uniform output over the range of mix levels available. Clipping will never occur, even with full scale input channels and mix levels.
- Level B: Downmix output level is normalized based on the channel configuration to provide a uniform output loudness between 3/2 and 2/0 programs. Downmixing a 3/2 program produces a loudness attenuation compared to the same program in 2/0 at the same input loudness. To provide a uniform output loudness, a loudness attenuation is applied only on 2/0 programs. If the operating mode is *Follow Metadata*, the channel configuration is given by the Dolby Digital coding mode parameter in the metadata. If the operating mode is *Manual*, the channel configuration is given by the selected mix levels: a 2/0 channel configuration is achieved by setting Center, Surround, and LFE Mix Levels to *Mute*. Any other combination of mix levels is assumed to be a 3/2 channel configuration. Level-B normalization also includes Level-A normalization, based on the applied mix levels. Clipping will never occur, even with full scale input channels and mix levels.



Figure 5.16 Audio Processing - Downmix

- This selection is not available when *Oper. Mode* is OFF.

Output Channels: Select the audio channels whose content will be replaced by the output of the downmix processor

- 7&8
- 15&16
- 23&24
- 31&32
- This selection is not available when the *Operating Mode* is OFF (downmix disabled).

Manual Downmix Config / Default Metadata Config

The heading of this area of the panel changes depending on the selection in the *Operating Mode* pulldown above, but the available controls are the same in both cases.

- Operating Mode = Manual – the controls are used to set up the Manual Downmix parameters.
- Operating Mode = Follow Metadata – the controls are used to set up the default downmix parameters for situations where there is no metadata available.

Mode: this pulldown menu selects the downmix mode:

- LtRt: Enables the downmix of 5.1 channels into an LtRt (Left total Right total) matrix surround encoded stereo pair. The input signals on the channel pair selected as the Output Channels are discarded.

GUIDE TO INSTALLATION AND OPERATION

- LoRo: Enables the downmix of 5.1 channels into an LoRo (Left only Right only) stereo pair, which is a conventional stereo signal. The input signals on the channel pair selected as the Output Channels are discarded.

Dialnorm: this pulldown selects the dialog normalization level. Select OFF to prevent the downmix from applying the dialnorm.

[OFF, -1 dBFS, -2 dBFS, -3 dBFS,, -31 dBFS]

Center Mix Level – sets the center channel downmix level to the selected value

[+3 dB, +1.5dB, 0 dB, -1.5 dB, -3 dB, -4.5 dB, -6 dB, Mute]

Surround Mix Level – sets the surround channels (Ls & Rs) downmix level to the selected value

[+3 dB, +1.5dB, 0 dB, -1.5 dB, -3 dB, -4.5 dB, -6 dB, Mute]

LFE Mix Level – sets the LFE channels downmix level to the selected value.

[+10 dB, +9 dB, +7.5, +6 dB, +4.5 dB, +3 dB, +1.5dB, 0 dB, -1.5 dB, -3 dB, -4.5 dB, -6 dB, Mute]

- Note: The *LFE Mix Level* pulldown sets the LFE downmix level for both *Manual* and *Follow Metadata* operation modes, whether or not the metadata is present in the selected path.

The block diagrams below show the configuration of the LtRt surround sound downmixer and the LoRo stereo downmixer.

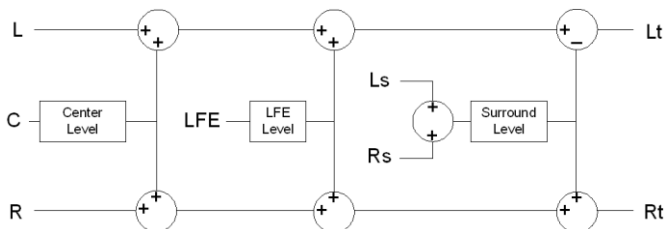

Figure 5.17 LtRt Surround Sound downmixer

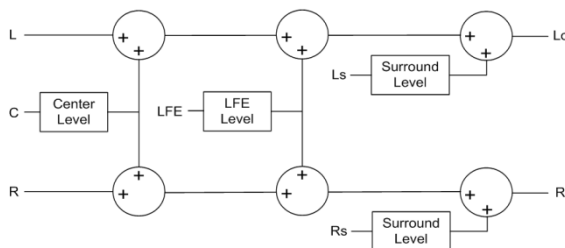

Figure 5.18 LoRo Stereo downmixer

Follow Metadata Config:

This section reports on Metadata presence if the *Follow Metadata* Operating Mode is selected. The four data boxes below the Metadata status icon indicate the current mode, plus the values in use for Dialnorm, Center Mix Level and Surround Mix Level.

- The user can choose whether to use the available Dialnorm value in the downmix process by selecting ON or OFF from the pulldown list at the bottom of the section.

5.4.5 AES Inputs tab

The AMX-3981 processes 32 channels of audio. The sources of the channels are:

Channels 1-16: Audio embedded in the incoming SDI stream

Channels 17-32 Audio from the eight AES inputs on the rear panel

Each of the rear panel AES inputs is provided with a sample rate converter that will convert the sample rate of the AES input to match the sample rate of the audio data embedded in the incoming SDI stream

5.4.6 Status tab

The Status tab reports the type of audio present at the input and the Dolby E alignment.

Audio Type Status:

- PCM – the audio channel carries PCM audio (orange)
- Dolby E – the audio channel carries Dolby E encoded audio (blue)
- AC3 – the audio channel carries Dolby Digital encoded audio (violet)
- NPCM – the audio channel carries Dolby Digital Plus or non-PCM other than Dolby E or Dolby Digital (yellow).

Dolby E Alignment:

- When Dolby E audio is present, this panel will display the offset/delay between the Dolby E and the video output timing of the card. You may click the Auto Align button to automatically adjust the audio timing delay to ensure a perfect alignment with the video. This is equivalent to changing manually the audio delay in the audio processor. If you change the output timing of the card or the video output format, you may have to re-align the Dolby E.
- The offset is not available for any type of audio other than Dolby E.

The measured Dolby E offset can be a positive OR a negative value. A negative value indicates the Dolby E is in advance compared to the video and additional delay should be added to the audio channel pair.

A positive value indicates the Dolby E is late compared to the video and the audio delay must be reduced for this channel pair. Sometimes, the audio delay cannot be compensated because it would mean to have an audio delay lower than the processing delay of the card. In this case, you have to add an extra frame delay to the video to provide more range to the audio delay.

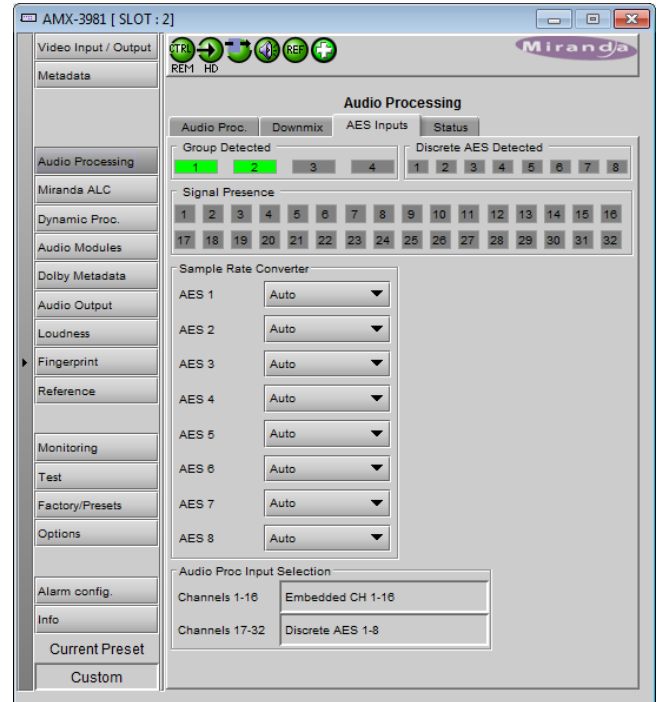

Figure 5.19 Audio Processing – AES Inputs



Figure 5.20 Audio Processing - Status

5.5 Miranda ALC panel

Minimizing loudness differences between segments in a playout channel is an important issue in a world where multiple programs originating in different formats from different sources must be integrated seamlessly. The Automatic Loudness Control (ALC) option is the solution to this need. It uses Grass Valley's proprietary *wideband* ALC algorithm.

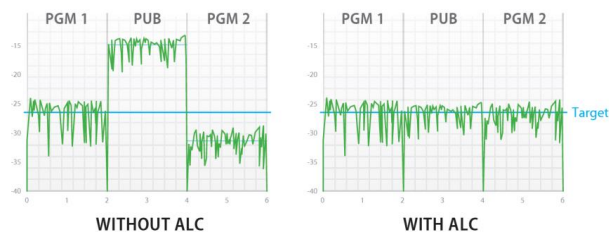

- Identified as AMX-3981-OPT-ALC-X, where X can be 2, 6, 8 or 16 input channels. The table shows the ALC models available:

Model	Description	Program types supported
AMX-3981-OPT-ALC-2	2-Channel ALC, up to 2 independent programs	Mono, 2.0
AMX-3981-OPT-ALC-6	6-Channel ALC, up to 6 independent programs	Mono, 2.0, 3.0, 4.0, 5.1
AMX-3981-OPT-ALC-8	8-Channel ALC, up to 8 independent programs	Mono, 2.0, 3.0, 4.0, 5.1, 7.1
AMX-3981-OPT-ALC-16	16-Channel ALC, up to 8 independent programs	Mono, 2.0, 3.0, 4.0, 5.1, 7.1

Note: The ALC works with PCM audio. If non-PCM audio like Dolby E or Dolby Digital and Dolby Digital Plus is fed to the module, it will be ignored and all the program channels will be bypassed to prevent interference with the other PCM audio channels.

5.5.1 Config tab

Channels per program

Pull-downs are available to select the number of channels per program. Depending on the ALC model, you may have different possible selections, from 1 to 8 channels per program.

Input channels selection

An input shuffler allows any combination of the available channels to be used as inputs to each ALC program.

Note: An input channel cannot be assigned to more than one (1) program, and can only be used once within a program.

Global Config

The *Mode* pull-down selects preset values for target, sliding window and loudness units that apply to loudness monitoring for all programs on this AMX-3981:

Mode	Target	Short-Term Time Window	Loudness Unit
EBU R128-2014	-23	3 sec	LUFS
ATSC A85 :2013	-24	10 sec	LKFS
ARIB TR-B32	-24	3 sec	LKFS

Enable Loudness Monitoring turns ON the ALC input and output loudness monitoring for all programs.



Figure 5.21 Miranda ALC – Config tab

5.5.2 PGM1-8 tabs

Loudness monitoring

When turned ON, the loudness meters display the program input loudness (before ALC processing), the dynamic correction applied by the ALC, the ALC limiter correction, and the program output loudness (after ALC processing).

The input and output loudness are given in **LUFS** or **LKFS**, depending on the modes selected in the Config tab. Loudness meters are integrated over a “sliding-window” period which is also mode-dependent.

Dynamic and limiter corrections are always given in dB. Each correction meter is integrated over a period of 250 milliseconds.

ALC Presets

Three factory presets for the ALC are available to cover most broadcast applications.

- **Factory Light** – The ALC applies low dynamic range compression on the audio program content. The overall response time is relatively slow, which reduces the ALC ability to tightly follow the target output loudness. Using this preset, the program content will sound a little more dense, while keeping most of the original program dynamic range.
- **Factory Standard** – The ALC applies moderate dynamic range compression on the audio program content. The overall response time is also moderate, which allows the ALC to follow the target output loudness quite well. This preset is well-suited for most types of audio content. It is the factory preset loaded when loading the card default parameters.
- **Factory Heavy** – The ALC applies high dynamic range compression on the audio program content. The overall response time is relatively fast, which improves the ALC ability to tightly follow the target output loudness. Using this preset, the program output content will sound much more dense, less dynamic.

Five user presets are also available to save and load custom configurations of the ALC. These presets are labeled ALC 1 to 5 but the user can edit the preset names via the “Edit Labels” button.

We **STRONGLY** recommend starting with the ALC factory preset (Light, Standard, Heavy) that is closest to the desired objective, then fine tuning it to reach the desired goal. This will minimize the troubles that will likely be encountered as many adjustments interact.

ALC Bypass

Checking this box bypasses the ALC program processing, and the input channels pass through to the output unaltered.

Target Loudness

Sets the target output loudness. This value sets the *average* output loudness, which means that due to the program dynamics, the output loudness will move around the selected target. The units of measurement and the nominal value, as well as the window size for the measurements (not shown on this panel) are set by the *Mode* pulldown in the Config tab.

Although the nominal Target Loudness is reset according to the table above when the *Mode* is changed, the user may change the value at any time using the pulldown, where the available range is -10 to -31 for all modes.

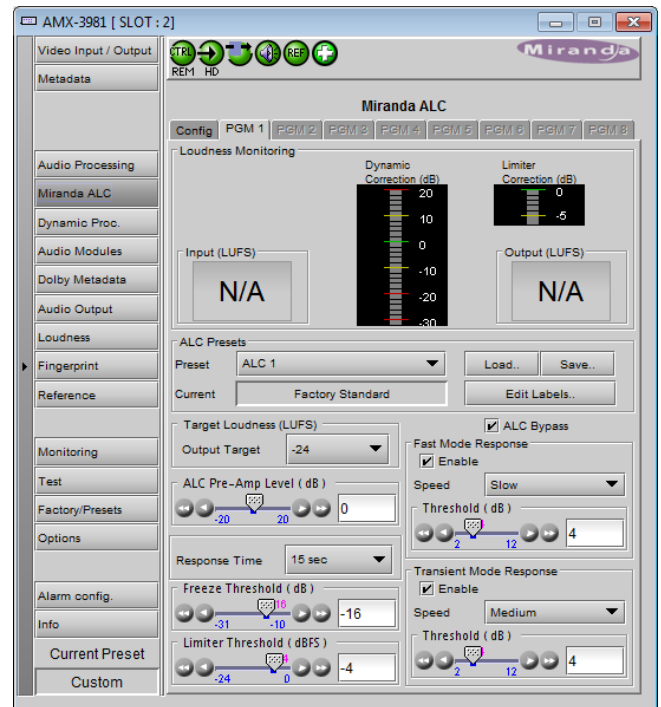

Here's the time-domain response of the ALC:

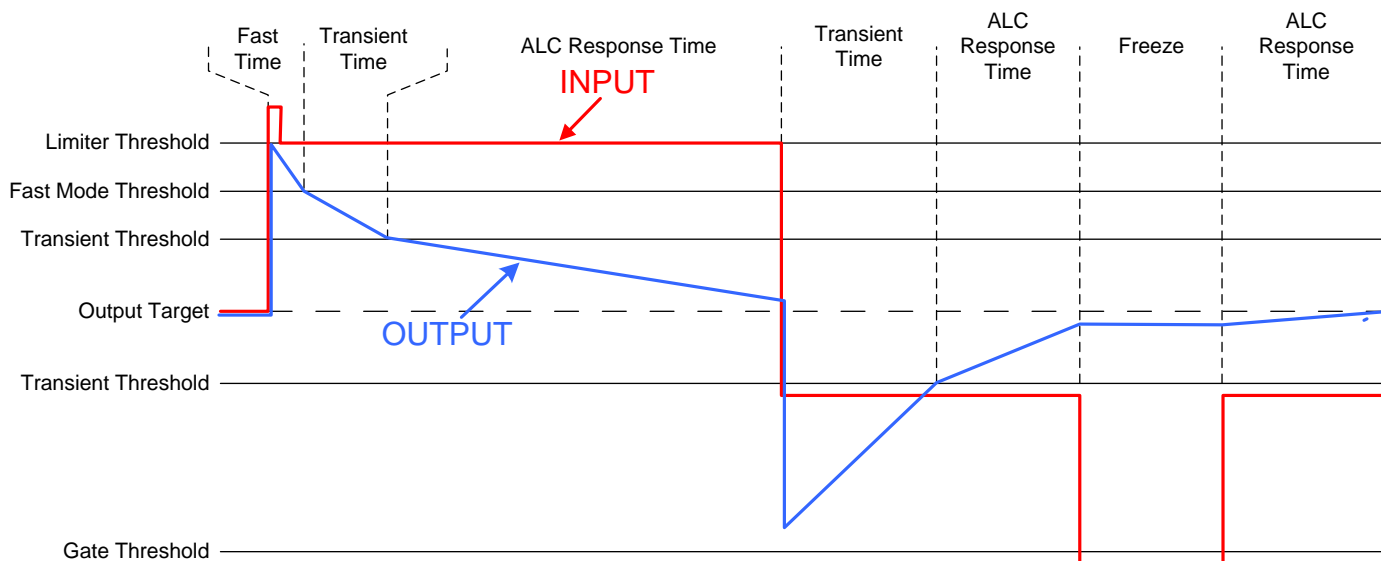

ALC Pre-Amp Level

A pre-amp stage is available in front of the ALC to compensate for programs having an input loudness out of the ALC tracking range (very low or very high input loudness). The pre-amp level ranges from -20 dB to + 20 dB, in steps of 1 dB.

Fast Mode Response

The *Fast Mode Response* is optional and is enabled by checking the **Enable** box.

The ALC *Fast Mode Response* kicks in whenever the input loudness goes over the **Fast Mode Threshold** and loudness is reduced, in a few milliseconds. The **Fast Mode Threshold** is given in dB with respect to the target loudness and ranges from 2 to 12 dB, in dB steps.

Transient Mode Response

The *Transient Mode Response* is optional and is enabled by checking the **Enable** box.

The ALC *Transient Mode Response* kicks in whenever the input loudness goes over or under the **Transient Mode Threshold**. The **Transient Mode Threshold** is symmetric with respect to the target loudness and ranges from 2 to 12 dB, in dB steps. When the input loudness is over the **Transient Mode Threshold**, loudness is reduced following the rate set by the **Speed** pull-down. When the input loudness is under the **Transient Mode Threshold**, loudness is increased, again following the **Speed** pull-down, which ranges from Slow (up to 15 seconds) to Fast (up to 4 seconds).

Response Time

Outside of the *Fast* and *Transient* modes ranges, the ALC performs loudness correction slowly, following the **Response Time**. Response time values are : 5 sec, 10 sec, 15 sec, 20 sec, 30 sec, 45 sec, 1 min, 5 min, 10 min, 15 min, 20 min.

Freeze Threshold

The **Freeze Threshold** sets the threshold below which the ALC will not increase loudness. This prevents quiet portions of programs (and noise) from being unintentionally boosted. If the input program loudness is under the **Freeze Threshold** for more than 30 seconds, the ALC will smoothly return to 0 dB of loudness correction.

Limiters Threshold

The **Limiters Threshold** will limit the output loudness under the selected threshold. This avoids unintentional clipping of loud portions of programs. If the input program loudness is over the **Limiters Threshold**, the ALC will reduce the loudness very quickly, in 1 millisecond.

5.6 Dynamic Processing panel

This panel provides controls for dynamic processing of the audio passing through the AMX-3981

- The Dynamic Processing Option (AMX-3981-OPT-DP) must be activated to access this functionality. See page 72.

Individual and independent controls are provided for each of the 32 channels.

These parameters affect the output audio channels (HD/SD embedded and AES), and the audio channels assigned to the Dolby E encoder and the Dolby Digital and Dolby Digital Plus encoder modules.

Note that, unlike the audio processing configuration, only one (1) dynamic processing configuration is saved by the card, regardless of the input format (3G/HD or SD).

- Access the individual channel controls through 4 master tabs and sub-tabs

The functionality of these controls is identical for each channel, and is explained here.

The upper right-hand corner of each tab contains a graphic depicting the transfer characteristic of the channel as configured by the current dynamic processing settings. Images will be shown below to illustrate the effect of the various controls

Mode

Use the pulldown to select the operating mode for this channel, from among these options:

- Mono:** applies the dynamics processing settings only to the selected channel
- Stereo:** applies the dynamics processing settings to the channel pair (e.g. 1 & 2, 7 & 8, etc.)
- Group 1:** applies the dynamics processing settings only to the channel assigned to Group 1
- Group 2:** applies the dynamics processing settings only to the channel assigned to Group 2

Click the *Bypass Settings* checkbox to bypass all the dynamics processing settings set up in this panel for this channel.



Figure 5.23 Dynamic Processing panel

Dynamic Gain

Sets the audio dynamic gain from 0 to 24 dB (in 1 dB steps) applied to the selected channel. The dynamic gain is applied at the end of the dynamics processing chain.

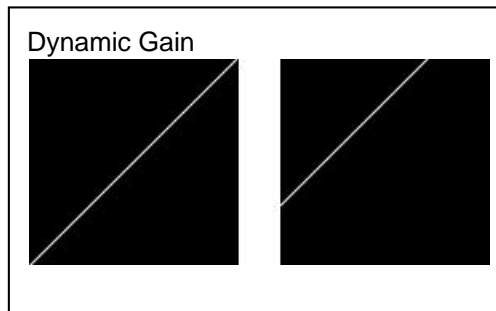

Limiter Threshold

A *limiter* is a type of compressor designed for a specific purpose, to limit the level of a signal to a certain threshold. Whereas a compressor will begin smoothly reducing the gain above the threshold, a limiter will almost completely prevent any additional gain above the threshold. A limiter is like a compressor set to a very high compression ratio (typically $1/\infty$).

For example, if the limiter threshold is set to -20 dBFS and the input signal level is -10 dBFS (10 dB above the threshold), the signal level at the output of the limiter will be -20 dBFS.

- Use the *Limiter Threshold* slider to set the threshold from -20 dBFS to 0 dBFS (1 dB steps).

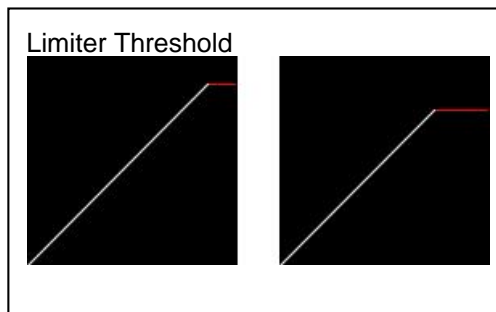

Compressor

Audio compression is a method of reducing the dynamic range of a signal. All signal levels above the specified threshold are reduced by the specified ratio. When the signal level exceeds the threshold, the compressor will begin smoothly to reduce the gain, following the attack time, until the output level reflects the specified compression ratio. When the signal level is below the threshold, the compressor will begin smoothly to increase the gain, following the release time, until the output level matches the input level.

For example, if the compressor threshold is set to -20 dBFS and a ratio of 1/2, and the input signal level is -10 dBFS (10 dB above the threshold), the signal level at the output of the compressor will be smoothly reduced to -15 dBFS (following the attack time). Then, if the input signal level suddenly drops to -30 dBFS (10 dB below the threshold), the signal level at the output of the compressor will smoothly go back to -30 dBFS (following the release time).

Use the *Attack Time* pulldown to set the attack time. The attack time specifies how fast the compressor will reduce the gain:

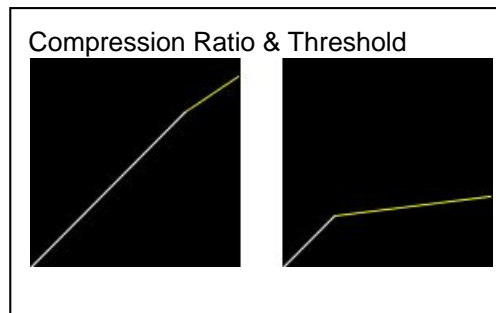

- Possible values: 1 ms, 5 ms, 10 ms, 20 ms, 40 ms, 80 ms, 160 ms.

Use the *Release Time* pulldown to set the release time. The release time specifies how fast the compressor will increase the gain:

- Possible values: 48 dB/s, 36 dB/s, 24 dB/s, 18 dB/s, 12 dB/s, 9 dB/s, 6 dB/s

Use the *Ratio* pulldown to set the compression ratio (i.e. slope of the transfer curve). The compression ratio specifies how much the output level changes with respect to the input level:

- Possible values: 1/1 (OFF), 1/1.25, 1/1.5, 1/1.75, 1/2, 1/3, 1/4, 1/8, 1/16

Use the *Threshold* slider to set the compression threshold (i.e. break point in the transfer curve). The compression threshold specifies the level above which the compressor will process the signal.

- Range -60 dB to 0 dB

Expander

Audio expansion means to expand the dynamic range of a signal. It is basically the opposite of audio compression. Like compressors and limiters, an audio expander has an adjustable threshold and ratio. Whereas compression and limiting take effect whenever the signal goes *above* the threshold, expansion effects signal levels *below* the threshold. Any signal below the threshold is expanded downwards by the specified ratio.

For example, if the expander threshold is set to -40 dBFS and a ratio of 2/1, and the input signal level is -60 dBFS (20 dB below the threshold), the signal level at the output of the expander will be reduced to -80 dBFS. Then, if the input signal level suddenly increases to -30 dBFS (10 dB above the threshold), the signal level at the output of the expander will go back to -30 dBFS.

Use the *Ratio* pulldown to set the expansion ratio (i.e. slope of the transfer curve). The expansion ratio specifies how much the output level changes with respect to the input level :

- Options available: 1/1 (OFF), 1.125/1, 1.25/1, 1.375/1, 1.5/1, 1.625/1, 1.75/1, 1.875/1, 2/1

Use the *Threshold* slider to set the expansion threshold (i.e. break point in the transfer curve). The expansion threshold specifies the level below which the expander will process the signal.

- Range -80 dB to -40 dB

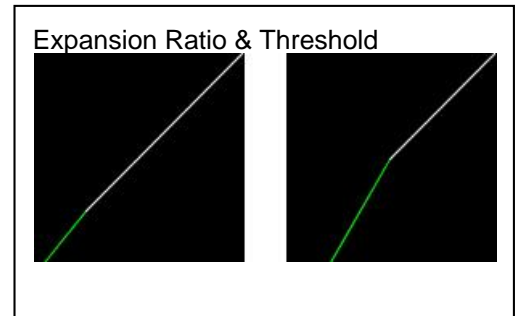

Dynamics for 1 minute.

Click the *Dynamics for 1 minute* button to display the dynamics processing in the meters at the bottom of the panel for a period of one minute. Dynamics metering is enabled by groups of 16 channels: Channels 1-16 or Channels 17-32, selected depending on the *Channels* tab selected at the top of the panel



Figure 5.24 Dynamics for 1 minute display

- The right-hand portion of this section shows the output channels of the dynamics processor on level meters, as found in the RALM panel.
- The left-hand side shows approximately how much dynamic processing is being applied to the signal (by amplitude) on a channel basis.
- The example shown above is the result of substantial compression being applied to Channel 1

5.7 Audio Modules panel

This panel displays the controls for an audio module that may optionally be installed in a socket on the AMX-3981 card.

See [Audio Modules](#) beginning on page 79 for detailed descriptions of all of the available modules and their associated control panels.



5.8 Dolby Metadata panel

This panel provides resources for managing the flow of Dolby metadata through the AMX-3981.

Multiple layers of tabs allow the user to drill down to the various available controls. For notational purposes, the path to a particular control panel will be described here as:

[layer 1 tab] → [layer 2 tab] → [layer 3 tab]

For example, the panel shown in the figure on the right would be described as:

[Config] → [Delay]

5.8.1 Config tab

Input Presence: Status icons are provided to indicate sources where Dolby Metadata is present and valid. The following are shown:

- VANC Stream
- RS-422B
- Decoder (grey if not installed)

Source: This area allows source selection.

- The currently-active pathway is shown in green.

Primary: Use this pulldown list to select the primary metadata source for this path.

The pulldown list shows the same sources appearing in the Input Presence section. The Decoder source will appear in red if the module is not installed.

Note: When decoding PCM audio, the Dolby decoder does not generate any metadata. If a decoder is selected as a source for a specified metadata path, the generator on the same path will be automatically turned ON when the decoder is decoding PCM audio. The content of the generator must have been previously configured. Refer to “Generator automated mode” below for details.

Backup: use this pulldown list to select the source that will be used if the primary source becomes unavailable or invalid. In addition to the available primary sources, the list includes:

- Last valid – return to the last valid source used
- Blank – no metadata output
- Generator – use the internal generator

Generator: Use this pulldown list to turn the internal generator ON or OFF. Turning it ON selects it as the source. The generator creates a complete, specific set of metadata, which is configured in the Generator tab.

Generator automated mode:

The generator is turned on or off automatically in specific conditions to avoid loss of metadata at the output stream. There are two specific conditions which will trigger the automation behaviors:



Figure 5.25 Dolby Metadata panel

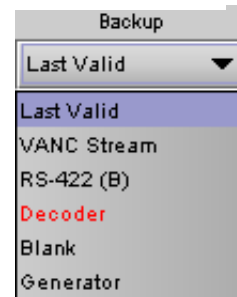

1. When a Dolby decoder module is installed and selected as the metadata source of a path, the audio metadata from a Dolby E input stream will be decoded and passed. When the decoder is fed with PCM audio, the Dolby decoder will not provide metadata. Instead, the generator will be automatically turned on. It is the responsibility of the user to configure the generator with the proper PCM metadata parameters.
2. When an upMAX™ module is installed and configured to operate in *Follow Metadata* mode, the resulting upMAX™ mode is dictated by the *coding mode* parameter of the probed metadata stream. When the metadata stream coding mode is 2/0, the upMAX™ mode is set to *Upmix* and the generator will be turned on to generate 5.1 metadata for the upmixed audio content. It is the responsibility of the user to configure the generator with the proper 5.1 metadata parameters. If the metadata stream coding mode is 3/2, the upMAX™ mode is set to *Pass* and the generator will be turned off to let the input metadata stream go through. If the coding mode detected is other than 2/0 or 3/2 or there is no metadata, the reversion mode is used. In that case, the generator will be turned on for the *Upmix* and *AutoMAX* reversion modes, and off for *Pass* reversion mode.

Note: No automation is provided for the generator content. The generator content is always under user control and must have been previously configured if used in these conditions.

Hold: Use the pulldown to select Hold ON or OFF.

- ON – freezes the Metadata values used in the output bitstream
- OFF - allows the current metadata to pass to the output

Probe: this box shows where the audio metadata probing occurs in the path.

5.8.1.1 [Config] → [Delay]

Through **Coarse** and **Fine** adjustments, a fixed delay can be applied to the Metadata bitstream. It is useful when processing, like watermarking, is applied to the audio signal outside the AMX-3981. The delayed Metadata bitstream will stay properly timed with its associated audio signal.

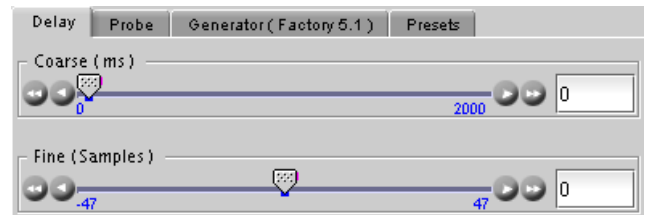

Figure 5.26 Dolby Metadata - [Config] → [Delay]

5.8.1.2 [Config] → [Probe]

The Probe function allows the user to view information about the Metadata in the program stream. There are no controls in this panel or its subpanels, except for the program select buttons.

The *Probe* section at the left of the panel shows information about the data stream in the metadata path.

- The two parameters at the top indicate the **Program Configuration** and the **Video Frame Rate** of the Metadata bitstream.
- Depending on the Program configuration, one to eight programs are included in a Metadata bitstream. The **Program Select** zone allows the selection of one Metadata program.

The text boxes below the program select buttons report on the data rate, coding mode and dialnorm value of the selected program.

[Config] → [Probe] → [Audio Processing]

This panel reports the status of the audio processing:

- DC Highpass Filter
- Bandwidth Lowpass Filter
- LFE Lowpass Filter
- Surround 90° Phase Shift
- Surround Channel Attenuator

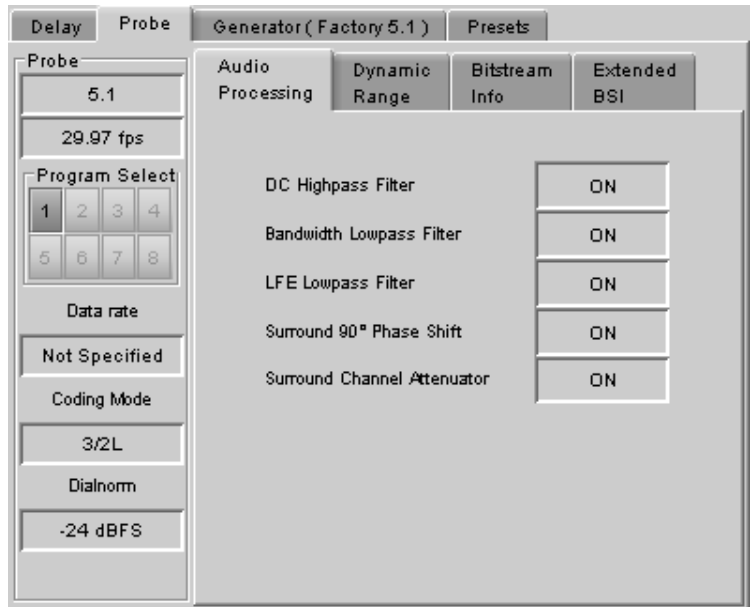

Figure 5.27 [Config] → [Probe] → [Audio Processing]

[Config] → [Probe] → [Dynamic Range]

This panel reports the status of Dynamic Range processing:

- Line Mode Profile
- RF Mode Profile
- RF Overmod. Protection

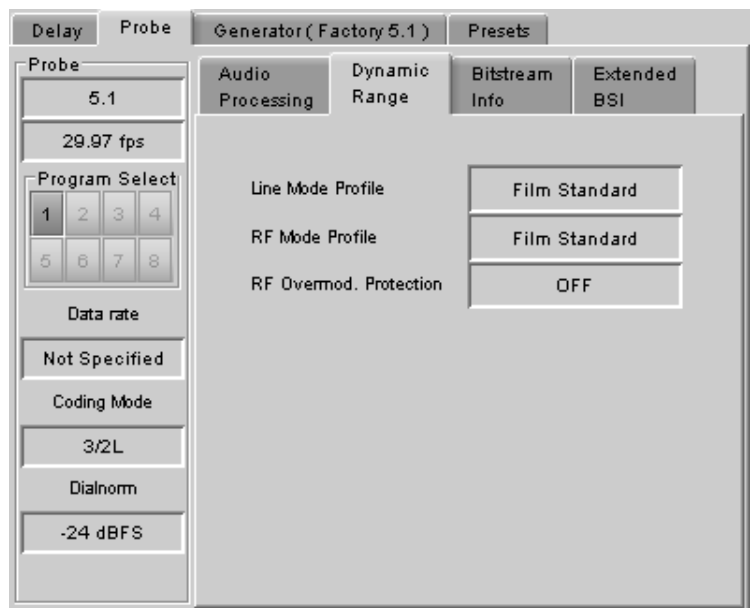

Figure 5.28 [Config] → [Probe] → [Dynamic Range]

[Config] → [Probe] → [Bitstream Info]

This panel reports the status of the metadata bitstream:

- Bitstream Mode
- Center Downmix Level
- Surr. Downmix Level
- Dolby Surr. Mode
- Copyright Bit
- Original Bitstream
- Audio Production Info
- Mix Level
- Room Type

Additional bitstream information is found in the Extended BSI tab

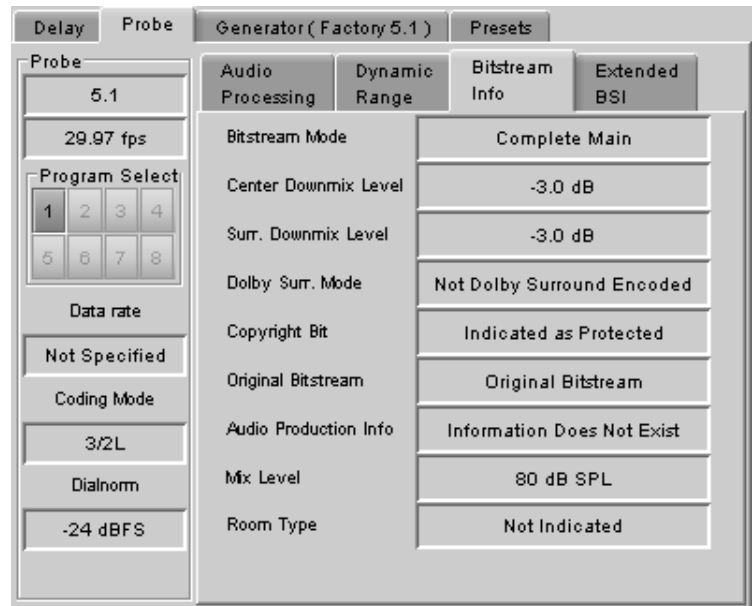

Figure 5.29 [Config] → [Probe] → [Bitstream Info]

[Config] → [Probe] → [Extended BSI]

- Preferred Stereo Downmix
- Lt/Rt Center Mix Level
- Lt/Rt Surround Mix Level
- Lo/Ro Center Mix Level
- Lo/Ro Surround Mix Level
- Surround EX mode
- Converter Type

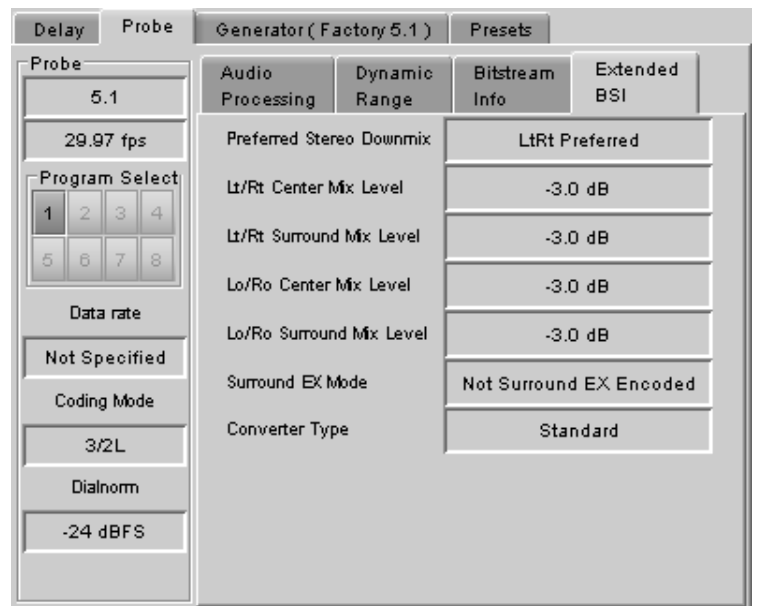

Figure 5.30 [Config] → [Probe] → [Extended BSI]

5.8.1.3 [Config] → [Generator]

The tab name includes a bracketed item (Factory 5.1 in the figure) indicating which metadata preset is currently loaded in the generator.

The upper left Pulldown list sets the **Program Configuration**. The text box below it shows the **Video Frame Rate**, which is set automatically by the card.

Use the Program Select buttons to select the program to configure.

Use the Coding Mode and Dialnorm pulldowns to set these parameters in the generator output.

[Config] → [Generator] → [Audio Processing]

This panel allows configuration of the audio processing parameters:

- Extended Bitstream info 1
- Extended Bitstream info 2
- DC Highpass Filter
- Bandwidth Lowpass Filter
- LFE Lowpass Filter
- Surround 90° Phase Shift
- Surround Channel Attenuator

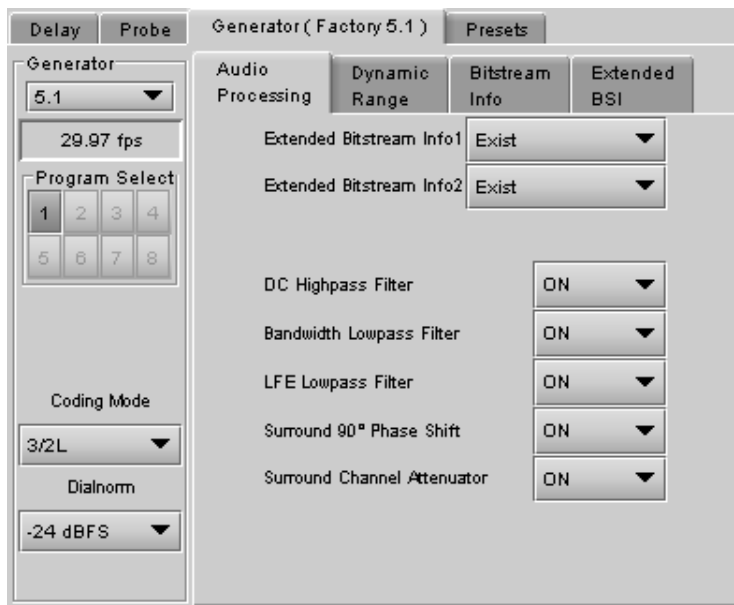

Figure 5.31 [Config] → [Generator] → [Audio Processing]

[Config] → [Generator] → [Dynamic Range]

This panel allows configuration of the Dynamic Range processing parameters:

- Line Mode Profile
[None, Film Standard, Film light, Music standard, Music light, Speech]
- RF Mode Profile
[None, Film Standard, Film light, Music standard, Music light, Speech]
- RF Overmod. Protection

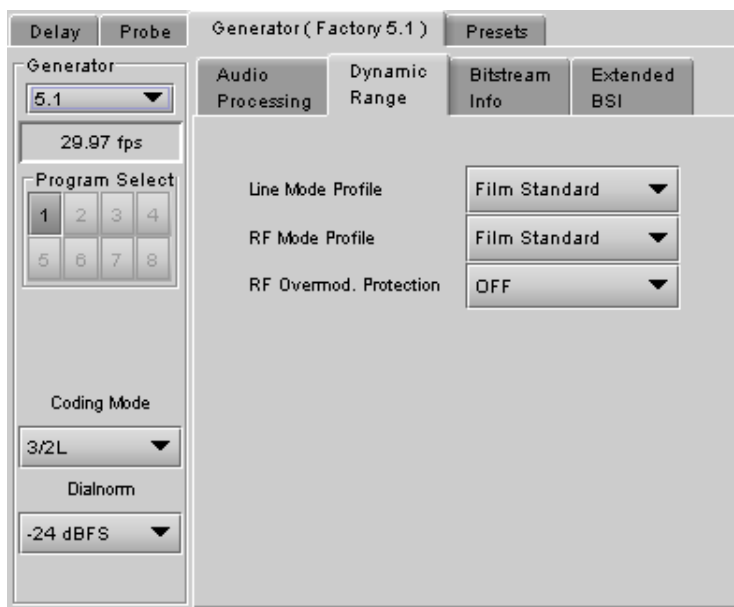

Figure 5.32 [Config] → [Generator] → [Dynamic Range]

[Config] → [Generator] → [Bitstream Info]

This panel allows configuration of the metadata bitstream info parameters. Use the pull downs to select the appropriate values:

- Bitstream Mode
- Center Downmix Level
- Surr. Downmix Level
- Dolby Surr. Mode
- Copyright Bit
- Original Bitstream
- Audio Production Info
- Mix Level
- Room Type

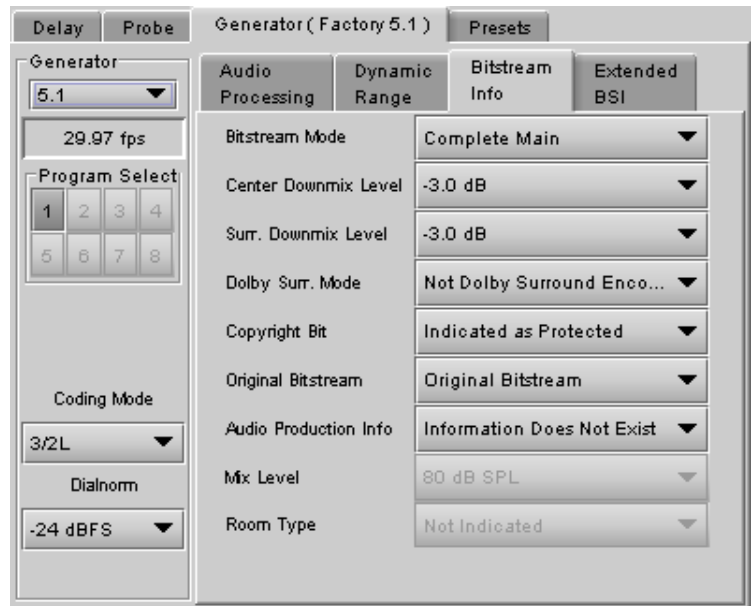

Figure 5.33 [Config] → [Generator] → [Bitstream Info]

[Config] → [Generator] → [Extended BSI]

- Preferred Stereo Downmix
- Lt/Rt Center Mix Level
- Lt/Rt Surround Mix Level
- LoRo Center Mix Level
- LoRo surround Mix Level
- Surround EX mode
- Converter Type

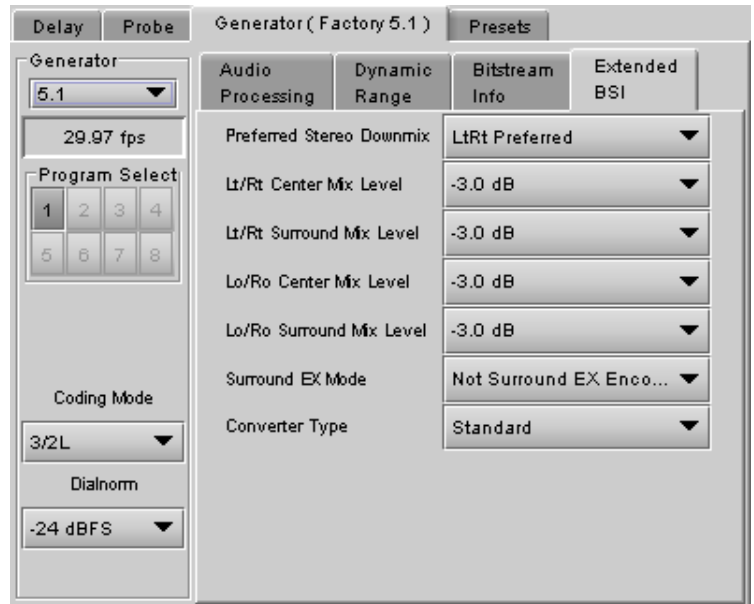

Figure 5.34 [Config] → [Generator] → [Extended BSI]

5.8.1.4 [Config] → [Presets]

Because there are many parameters to set for the generator, it is convenient to be able to save a configuration for easy recall. The Presets tab offers several convenient functions for this purpose.

The AMX-3981 allows the user to save five configurations. These are labeled META 1 to META 5 by default, but the user can edit the names via the **Edit Presets Labels...** button at the bottom of the tab, adding text in the brackets, e.g. META 3 (sample text).

In addition, the AMX-3981 is preloaded with two fixed data sets named Factory 2.0 and Factory 5.1.

The Current Generator Preset databox at the top of the tab reports the current preset in use.

- If all parameter values do not match the preset values, the box will show “Custom”.

The **Generator Presets** pulldown gives access to all seven available presets. The two buttons to the right then allow two options:

- Load – load the generator with the values stored in the preset, overwriting the current settings.
- Save – overwrite the values stored in the preset with the values currently set on the card (only for the five user-settable presets – the Factory presets cannot be changed).

The **Save Probe To** pulldown gives access to the five user-settable presets. Once one is selected, clicking on the Save button saves the values detected by the probe into the user presets, in effect setting the preset to match the current program stream.

Note – If you attempt to save the card configuration to a User Preset when the Metadata generator settings do not correspond to a Metadata Preset value (i.e. if the Current Generator Preset data box shows “Custom”), you will trigger a warning because of the way the Metadata Generator settings are saved. See page **Error! Bookmark not defined.** for a complete explanation. You may need to return to this panel and save the “custom” settings into a Metadata preset before you can save the card configuration to a User Preset.

- Avoid this by getting in the habit of saving the Generator Metadata settings each time you change them.

The **Metadata Profiles...** button opens the Metadata Profile Copy window, which allows the user to copy the card settings from this AMX-3981 to other AMX-3981 cards accessible via iControl. See Figure 5.36.

The **Copy profile from** line shows the current AMX-3981 card.

- The Profiles column contains a pulldown that lists the profiles that are available to copy.
- The list includes the generator, plus the 5 metadata presets.

You can save the selected profile to disk for future recall:

- Click the **Save profile to disk...** button and select a disk location and file name to save the file.

You can recall a previously-saved profile from disk and load it into the card:

- Click the **Restore profile from disk...** button and find the appropriate file.
- Click **Open** to load the contents of the file into the current AMX-3981 .

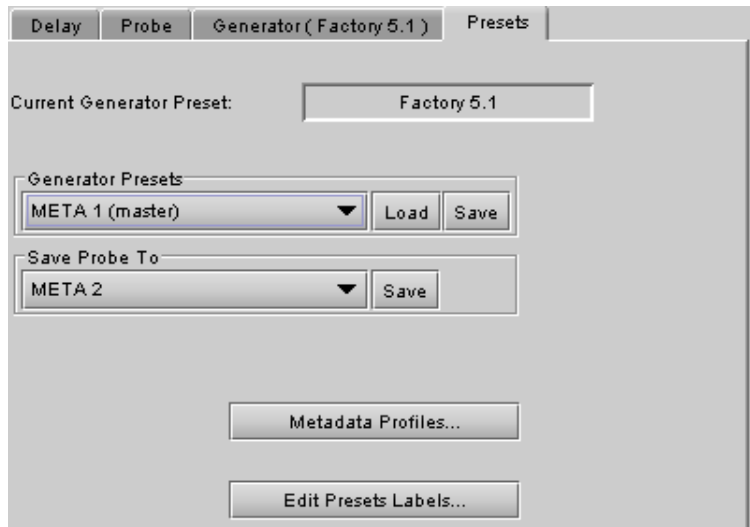

Figure 5.35 [Config] → [Presets]

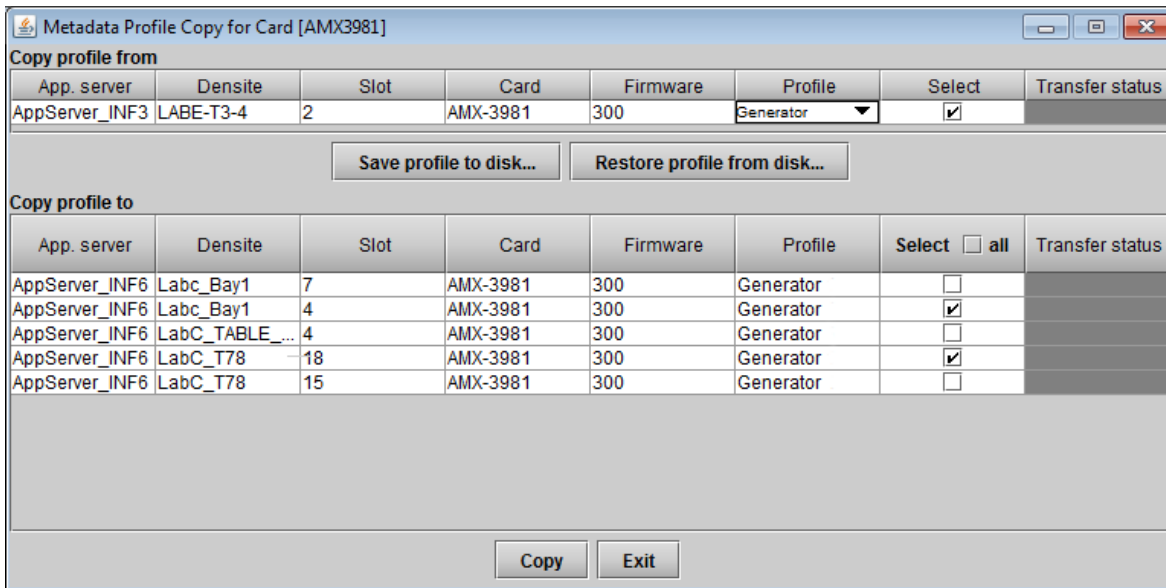

Figure 5.36 Metadata Profile Copy window

The **Copy profile to** area shows all other AMX-3981 cards that have been detected on the iControl network.

- The Profile column will show the same profile that was selected for the current AMX-3981 in the Profile pulldown.
- Click the *Select* checkbox for any cards to which you wish to copy the profile, or select all of them using the *Select All* checkbox in the column header. Note that you can only copy to cards with the same firmware release number.
- Click **Copy** to transfer the selected profile to the selected recipient cards.

5.8.2 Input/Output tab

This tab provides resources to configure the input and output selections and processing of metadata for the AMX-3981 card.

VANC Metadata Extractor

The card can extract a Dolby metadata stream from the VANC interval according to the specified SDID (range = 01 to 09). The presence of the stream is reported in the interface.

VANC Metadata Inserter

The card can insert a metadata stream in the VANC interval of the output. Use the pulldown lists to configure the metadata insertion.

Insertion: Enable metadata insertion

- Off: No metadata is inserted.
- Metadata: Metadata is inserted

Insertion Line: Select the VANC line in which the metadata will be inserted. The range depends on the output format:

- 3G/HD: lines 9 to 20
- SD (525) lines 12 to 19
- SD (625) lines 8 to 22

SDID: Select the VANC metadata packet SDID to be inserted. The SDID is used to specify the relationship between the VANC metadata stream and the first channel of its associated audio program.



Figure 5.37 Dolby Metadata – Input/Output tab

SDID	Associated channel pair
01	No association, or only one audio program
02	Channel pair 1&2
03	Channel pair 3&4
04	Channel pair 5&6
05	Channel pair 7&8
06	Channel pair 9&10
07	Channel pair 11&12
08	Channel pair 13&14
09	Channel pair 15&16

Note: If the card is configured to insert a special SDID at the output, any Dolby Metadata packets at the input with the same SDID will be deleted. Any other SDID packets not inserted by the card will be passed through untouched.

5.9 Audio Output panel

This panel provides additional audio processing for the 16 audio channels embedded in the 3G/HD/SD output:

- audio channel shuffling
- level adjustment
- mixing
- audio embedding mode.

You can configure the audio output shufflers/mixers (3G/HD, SD and AES) differently for an SD input than for a 3G/HD input. The card will remember the different parameters and will load them automatically without user intervention based on whether the video input is SD or 3G/HD. Ensure the card has a video signal of the desired format before changing the configuration.

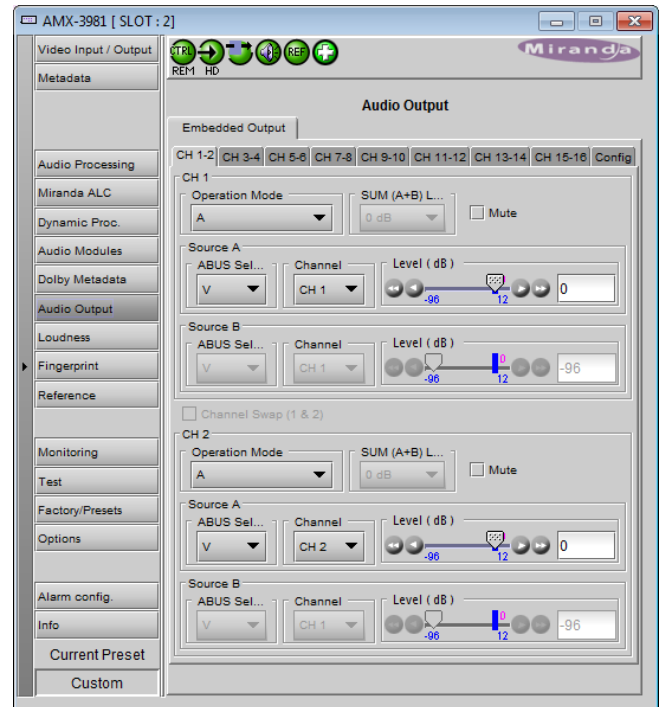

Figure 5.38 Audio Output panel

5.9.1 CH 1-2, CH 3-4, ... CH 15-16 tabs

Each of these tabs provides all necessary controls for the output mixers. The example shown is for the Embedded Output, CH 1-2, but all panels have the same controls.

Operation Mode (Off, A, SUM(A+B), Mix, Mix 4CH): This menu allows the source(s) of each output channel to be selected – a single channel, the sum of two channels, a mix of two channels, or on the even-numbered output channel only, a mix of three or four channels.

Off: The output channel is muted.

A: The output channel is the channel source (*ABUS Select* and *Channel*) selected in sub-menu SOURCE A.

SUM (A+B): The output channel is the sum of the two channels sources (*ABUS Select* and *Channel*) selected in sub-menus SOURCE A and SOURCE B.

- If you select this option, the SUM (A+B) Level pull-down is activated, allowing you to reduce the level of the summed output (0dB, -3dB or -6dB).

Mix: The output channel is a mono mix of the (*ABUS Select* and *Channel*) selected in sub-menus SOURCE A and SOURCE B.

Mix 4CH: This mode allows a 3-input or 4-input mix on the chosen even output. A standard 2-input mix is available on the odd output. On the same tab, the two selected sources of the even channel are mixed with the one or two selected sources of the odd channel. The four sources are mixed, with the level of each source adjusted using its slider or data entry box. You can swap the odd and even output by enabling the Channel Swap (1&2) checkbox. Note that in the Mix 4Ch mode, if the Mute box is checked, only the even channel sources will be muted, the odd channel sources will still pass to the output.

Note: in the case of SUM and MIX, if either of the two input channels is non-PCM, the output will always be SOURCE A

Mute: Mute the audio channel by checking this box. In the MIX4Ch mode, checking this box will mute only the sources of the selected output channel.

Source A & Source B: These sub-sections allow the source channels (A and B) to be selected for each output channel.

ABUS Select: V selects the embedded input audio. This is the only choice available at this time.

Channel: Channel 1, ..., Channel 16: selects the channel to be used from the selected audio source.

Level (dB): Sets the audio gain of the channel source from -96 to +12 dB in 0.5 dB steps. For non-PCM audio, the level value is overridden to 0 dB.

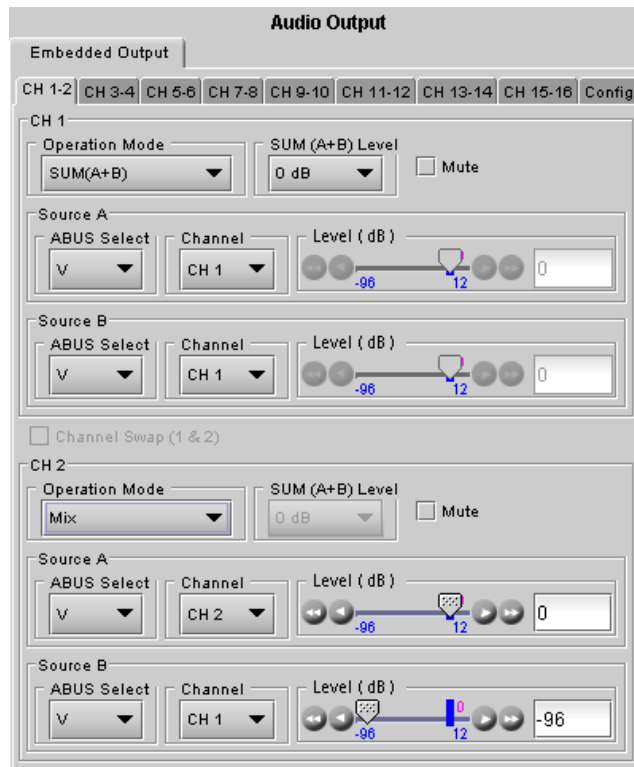

Figure 5.39 Audio Output operating controls

5.9.2 Config tab

The tab contains only an Audio Insert pulldown.

Use the pulldown in this tab to enable (AUTO) or disable (OFF) audio embedding in the output.

- When OFF is selected, no audio is embedded in the HD output.
- When AUTO is selected, only those audio groups containing at least one audio channel will be embedded at the output.

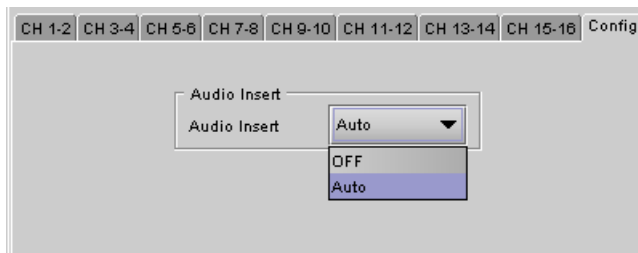

Figure 5.40 Audio Output - Embedded - Config tab

5.10 Loudness Panel

The AMX-3981 allows the user to measure the loudness of audio streams passing through it. The measurement process is flexible:

- All major loudness standards are supported.
- The measurement standards can be customized if desired.
- Up to four programs can be measured at once.
- Each program can be selected from an internal AMX-3981 metadata path, or defined manually.
- Segment markers can be inserted from a variety of triggers.
- Log files of the measurements can be stored externally, for analysis using Grass Valley's Audio Loudness Analyzer.

5.10.1 Loudness | Config panel

Global Config

All loudness measurements performed by this AMX-3981 conform to the same standard, which is selected here using the Meter Mode pulldown. Six options are available:

Standard	Target	Short-Term Time Window	Relative Gating	Loudness Unit
EBU R128-2010 (ITU-BS.1770)	-23	3 sec	-8 dB	LUFS
EBU R128-2014 (ITU-BS.1770-3)	-23	3 sec	-10 dB	LUFS
ATSC A85:2011 (ITU-BS.1770-1)	-24	10 sec	N/A	LKFS
ATSC A85:2013 (ITU-BS.1770-3)	-24	10 sec	-10 dB	LKFS
ARIB TR-B32 (ITU-BS.1770-3)	-24	3 sec	-10 dB	LKFS
Custom	-31 to -1	1 to 15 sec	-8, -10, N/A	LKFS

For the 5 defined standards, the other three pulldowns are inactive, but display their preset values in gray.

If Custom is selected, the other three pulldowns are active, and values can be chosen according to the user's needs. The range of available values is shown in the chart.

Global Control

The AMX-3981 can monitor loudness on up to four programs specified by the user.

- In this panel, select which programs will be active using the PGM 1 to PGM 4 checkboxes.
- The tabs for the selected programs will become active, allowing each program to be defined.

Enable Loudness Monitoring turns all loudness monitoring functions ON or OFF

RESET resets the measurements, and places a segment marker in the log file (but only if *User Event* is selected in the Segment Marker area).

- Note that you can also program a GPI to trigger a loudness reset - the control is located on the **Metadata | GPI** tab (see section 5.3.2 on page 27).

RUNNING / PAUSE shows the current status of the loudness monitoring.

- Click the button to change the status.
- PAUSE stops the measurement until the button is clicked again, but keeps the last value for logging and measurement.



Figure 5.41 Loudness panel – Config tab

Segment Marker

Select the checkboxes corresponding to the events for which you want a segment marker inserted in the loudness log file:

- User Event – a manually-triggered RESET (but not a PAUSE).
- GPI – a RESET triggered externally via GPI input.
- Dialnorm change – a change in Dialnorm value in the incoming metadata stream.
- Coding Mode Change – a change in the coding mode, either through the manual settings or detected in the incoming metadata stream.

Note that segment marker triggers in one PGM will generate segment markers in the logs for all PGMs.



Figure 5.42 Loudness panel – PGM 1 tab

5.10.2 Loudness | PGM panel

Four PGM panels – PGM 1, PGM 2, PGM 3 and PGM 4 – are available, each activated by selecting the appropriate checkbox in the LOUDNESS-CONFIG panel.

Use these panels to define the programs whose loudness will be monitored by this AMX-3981.

Program Settings

Operation Mode: Use the pulldown to select to source of the program definition:

Manual: Use the Manual Coding controls to define the program channel

Path: Use the path defined in the Dolby Metadata panel (see section 5.8.1 on page 44)

Manual program definition:

Select Manual in the Operation Mode pulldown.

Select the coding mode (e.g. 2/0, 3/2L, etc.) from the Manual Coding Mode pulldown

Assign inputs to the program channels using the Input Channels pulldowns

- For each program channel, input CH 1 to CH 32 can be selected
- Each input can only be selected once in a program.
- Only the program channels corresponding to the selected coding mode will be enabled

The chart shows the coding modes that are available, and the program channels that are enabled for each.

Coding Mode	Program Channels					
	Left	Right	Center	LFE	Ls	Rs
1/0			X			
2/0	X	X				
3/0	X	X	X			
3/0L	X	X	X	X		
2/1	X	X			X	
2/1L	X	X		X	X	
3/1	X	X	X		X	
3/1L	X	X	X	X	X	
2/2	X	X			X	X
2/2L	X	X		X	X	X
3/2	X	X	X		X	X
3/2L	X	X	X	X	X	X

Metadata Path program definition

If Metadata from the path is selected as the source, the Manual Coding Mode pulldown is disabled.

The Program Select switcher allows the user to select from among up to eight available programs (program 1 is the default selection).

Once a program is selected, its Dialnorm and Coding Mode are extracted and displayed in the data boxes below the switcher.

Note that:

- If the user selects Metadata path as the source, but no metadata is present, the selection defaults to Manual mode.
- In Manual mode, there is no dialnorm to extract.

Measurements

The Measurements area displays results from the loudness measurements performed on the selected program according to the settings made in the Config tab. The three data boxes show these values:

- Short term (S) Loudness averaged over the short-term time window set in the Config tab.
- True peak MAX Maximum true peak level found in all selected input channels
- Momentary MAX Loudness averaged over a 400 ms sliding rectangular time window

The chart shows a running plot of the last 15 seconds of the value of the Short Term (yellow trace) and Momentary (green trace) loudness values. The bar graph at the right indicates the current Momentary value.

A reset, initiated by a user via the Reset button on the Loudness | Config tab, or via a GPI event (configured on the Metadata | GPI tab; see **Load Presets** on page 27 for more information), will reset all of these measurements.

5.10.3 Loudness | Logging Panel

This panel monitors logging activity for all loggers connected to the application server associated with this AMX-3981 and its associated Densité frame.

- The Logging Activity icon will be GREEN when logging activity is detected.
- The number of loggers connected to the appserver is shown in the data box.

About Log Files

Loudness logs contain data for a period of up to 24 hours. New log files are started:

- when the logging function is enabled
- every 24 hours after logging was enabled, until logging is disabled
- when the reference changes
- when the global config is changed,

See [ANNEX 6 – Loudness Logging and the Audio Loudness Analyzer](#) beginning on page 110 for detailed instructions on activating logging and analyzing the logged data files.

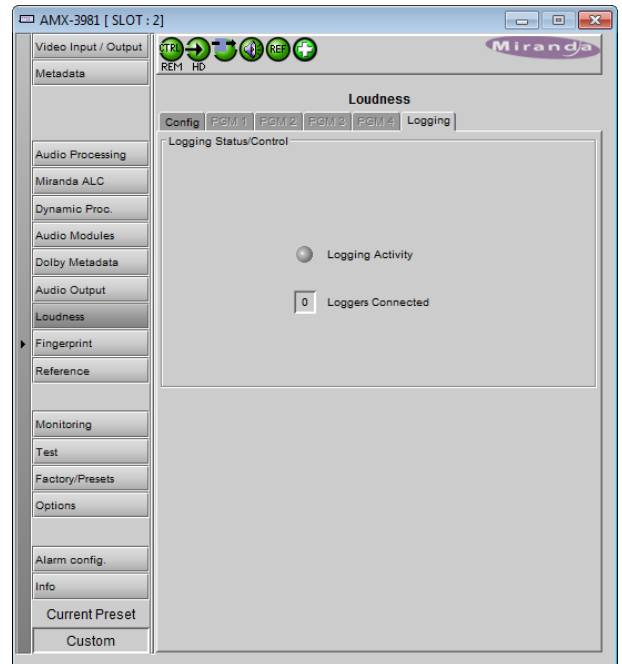

Figure 5.43 Loudness panel - Logging tab

5.11 Fingerprint panel

Fingerprinting technology on this card functions in conjunction with iControl.

- ***iControl 4.0 and higher is required.***

AMX-3981 streaming is ON by default, but the management of the stream is handled in iControl, and there is no local control of the process at this card control panel, except to select the window, and to turn streaming OFF if there are problems with the stream or the network.

See the iControl Version 4.00 User's Guide (Grass Valley document 226-99M00-271) or later, for a description of Fingerprint management in iControl.

The relevant text can be found in the section called 'Lip-Sync Detection and Monitoring' which is in the chapter titled 'Working with iControl as an Operator'

Zone

Select the area of the image within which fingerprint data will be calculated and streamed.

- The selected area is shown as a blue outline on the control panel window.

Default Window – a factory default is specified which is applied consistently to all Grass Valley fingerprinting devices.

It places the window in the central “action area” of the image, generally avoiding letterboxes and static graphics that are usually found in the periphery of the image.

Full Screen – opens the window to include the complete video image.

Start/Stop Line & Pixel – allows the user to create a custom window in response to particular or unusual image content.

- The custom window can be no smaller than half the picture width and half the picture height, but can be placed anywhere within the picture.

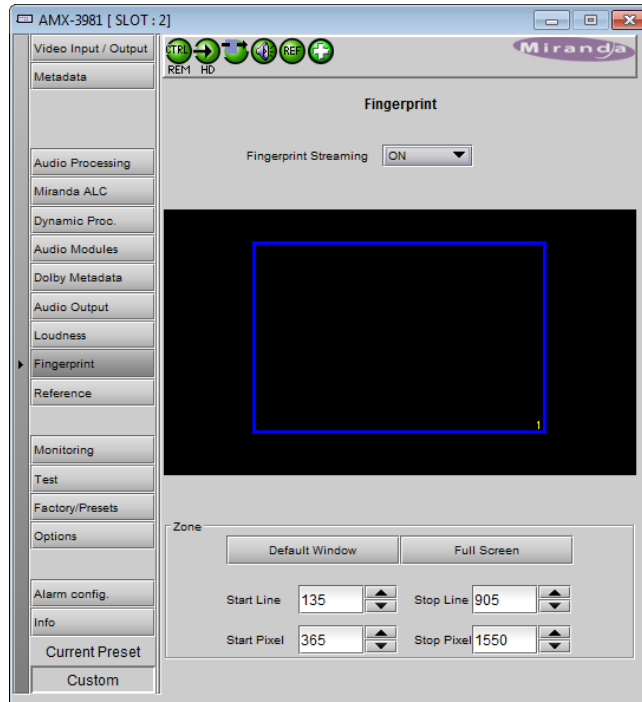

Figure 5.44 Fingerprint panel

5.12 Reference panel

This group of parameters allows the selection of the reference to be used by the AMX-3981.

Use the radio buttons in the Reference Source area to select from the following options:

- Auto – this mode selects the first source detected in this order of priority:
 - URS
 - Selected Input signal
- URS (Universal Reference Signal) – selects the internal reference from the backplane
- Input – uses the currently-selected input signal.

URS Format – use the radio buttons in the URS Format area to select whether the URS is OFF, 29.97 Hz or 25 Hz.

- When URS is OFF, the URS reference format source cannot be selected, and will also be ignored by the automatic detection mode.

Note: Make sure the input signal is locked to the selected reference signal at all times.

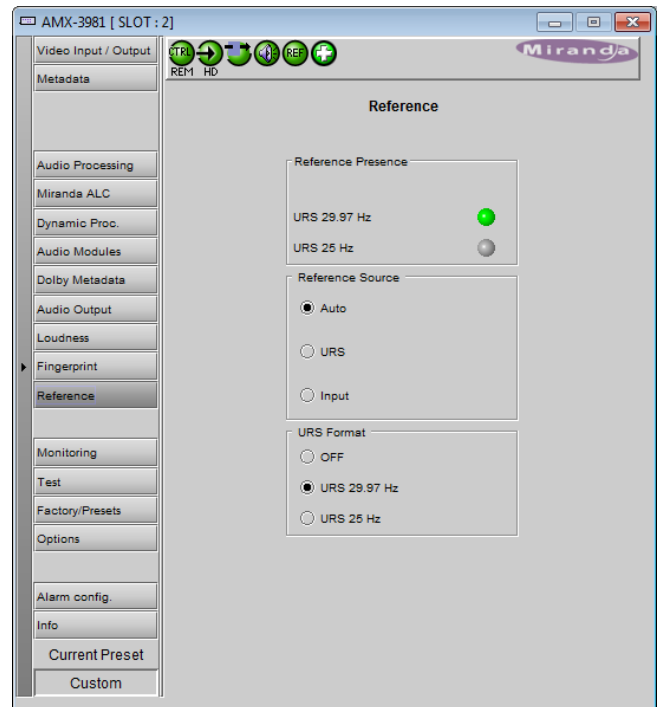

Figure 5.45 Reference panel

5.13 Monitoring panel

5.13.1 Thumbnails tab

The thumbnail area displays thumbnail images for the inputs and outputs selected in the Player area.

Player – Click the checkbox to display the thumbnail

Control – Click the checkboxes to apply the Mode, Format, Quality and Refresh Rate settings to these thumbnails.

Mode – select between Video mode and Test mode. Use Video mode for normal operation.

Format – choose the thumbnail size: small, medium, large

Quality – choose the quality of the displayed image by selecting Poor, Normal or HiQ (High Quality) from the pulldown list

Refresh Rate – select the desired refresh rate from the pulldown box. The choices are:

[Fast, 1 sec, 2 sec, ..., 9 sec, 10 sec.]



Figure 5.46 Monitoring - Thumbnails

5.13.2 RALM tab

The Remote Audio Level Meter (RALM) panel displays audio output level meters for up to 8 channels. Channels are displayed in pairs, so up to four meters will be present in the meter display window. The source for each meter is selected using the pull-downs in the RALM Remote Control area at the bottom of the control panel.

- OFF
- Embedded CH 1&2 up to CH 15&16

The meter is divided into three zones, and the dividing points and color of each zone are individually configurable under the *Meter Ballistics Config* tab.

Speed – select the meter response from the pull-down list, options are [fast, medium, slow]

5.13.2.1 RALM Connections tab

Use the radio buttons to turn the meter display ON (RALM) or OFF for the indicated channels. The meter appears directly above the controls.

Reset Counter: click this button to reset the overload counter on the ALM display to zero. See the next section for instructions on setting up the overload counter.

5.13.2.2 Meter Ballistics Config tab

Type – select a type of meter from the pull-down list

Upper Zone Limits – select the crossover level between the upper and middle zones of the meter (the range of values shown in the pull-down list depends on the type of meter selected)

Lower Zone Limits – select the crossover level between the middle and lower zones of the meter (the range of values shown in the pull-down list depends on the type of meter selected)

Color samples – the three samples show the current selected color for the upper, middle and lower zones of the meter.

- Click on the color sample of a zone to open a color selection panel to choose a different color for that zone



Figure 5.47 Monitoring - RALM tab



Figure 5.48 RALM - meter ballistics configuration

Overload Cursor – The overload cursor appears on the meter as an arrowhead in the meter scale. The two pulldown boxes set the position of the overload cursor on the left and right meters. If the audio level on that channel goes above the cursor, the Overload Counter at the top of the meter is incremented.

The **Overload Counter** shows a running count of the number of overloads detected. The Overload level is shown by a marker beside the meter, and its position can be set under the *Meter Ballistics Config* tab

The **Phasemeter** (located at the bottom of the RALM meter display) is a small meter that represents the phase correlation factor between the two channels of a pair.

Note – The level and phase meters are disabled for channels carrying non-PCM audio (Dolby E, Dolby Digital, Dolby Digital Plus or other non-PCM types).

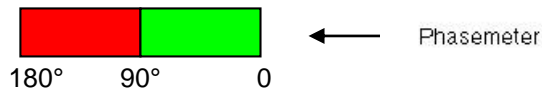
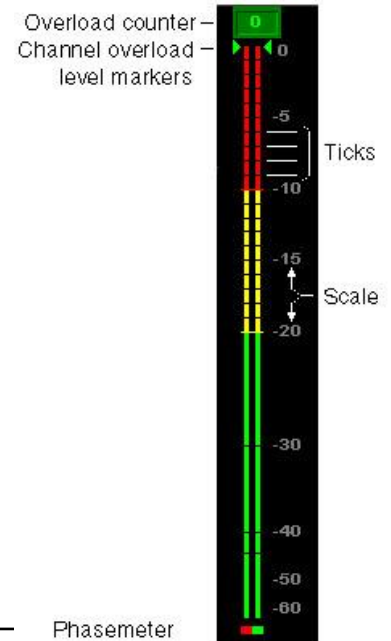

Figure 5.49 RALM meter display

5.14 Test panel

This panel contains a pulldown that allows the user to select an internally-generated test signal to replace the program signal at the AMX-3981 output.

OFF: the program signal appears at the output, and test signals are OFF

Color Bars and Tone: sends a 75% color bar test pattern (100% white), along with audio test tones (a continuous tone on right channel with pulsed tone on left channel in every pair) to the AMX-3981 output.

Lip Sync: sends a special test signal comprising color bars and tone plus a detectable element that is used to align audio-video delays in a processing path. This AMX-3981 becomes the transmitter in the alignment path. A second device (e.g. FRS-1801) will perform the measurement at the other end of the path.

- The special test signal consists of 75% color bars within which a white square is inserted every 4 seconds for a duration of 10 frames. Simultaneously with the beginning of the first field of video containing the white square, the 16 embedded audio channels and the 8 AES outputs are pulsed with a tone lasting 250 ms.

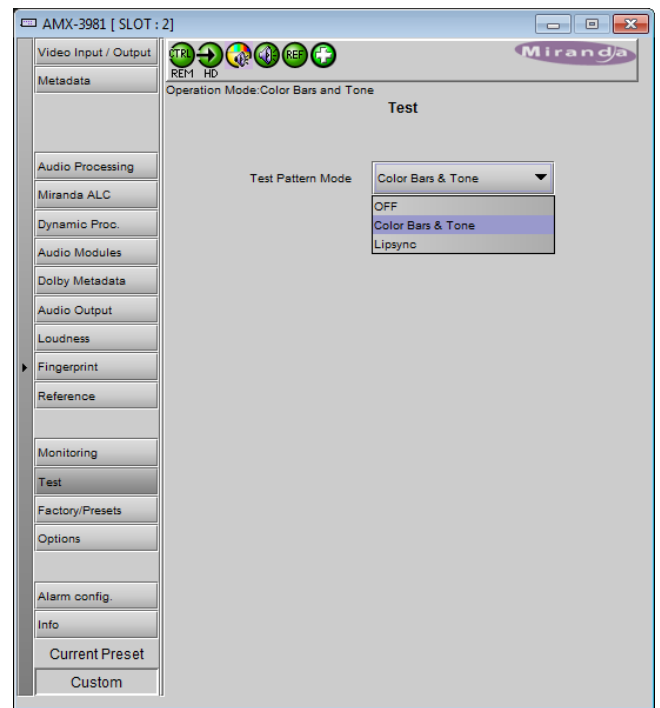

Figure 5.50 Test panel

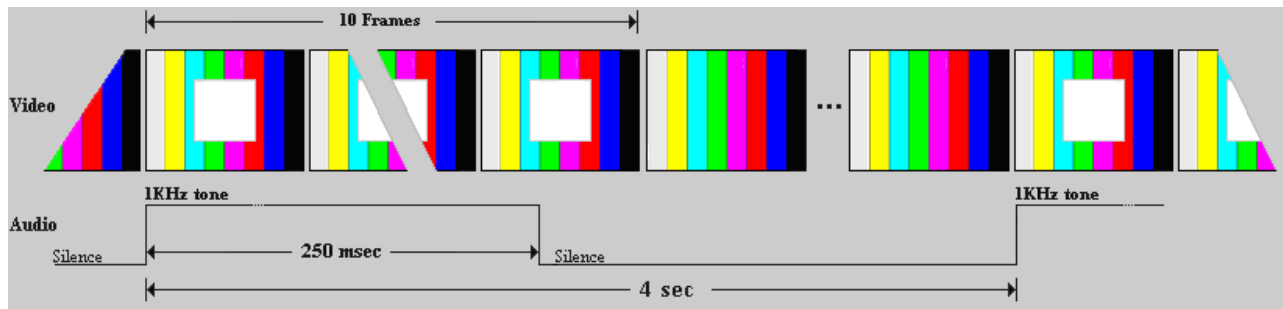

Figure 5.51 Lip Sync test signal appearance and timing

5.15 Factory/Presets panel

5.15.1 Factory/Presets tab

Factory Section

Load Factory: Clicking this button will restore the card to a factory default state. Two checkboxes enable the user to choose whether to include Parameters and/or Alarms in the restoration process

- Note that User Presets are not changed

User Presets section

The AMX-3981 has memory registers which can hold up to 5 user-defined parameter settings.

The *Current Preset* box (at the bottom left corner of the panel) displays the last loaded preset. Any change to the card configuration after a preset is loaded will change the display to "Custom" instead of the preset value.

Select any one of the five presets using the pull-down list. The name of the currently-selected User Preset is shown on the pulldown box.

Click **Load** to load the contents of the selected User Preset into the AMX-3981. All parameter settings and values will be replaced by the contents of the selected User Preset.

- The first 4 user presets can be recalled by GPI User Preset 1 to 4.

Click **Save** to store the current parameter settings and values from the AMX-3981 into the selected User Preset. The existing contents of the preset will be overwritten.

Note: if you see a pop-up warning box like this when you click **Save**, you will need to decide how to deal with the Metadata Generator presets. Click on the Metadata FAQ button to learn more about this issue.



Figure 5.52 Factory / Presets panel

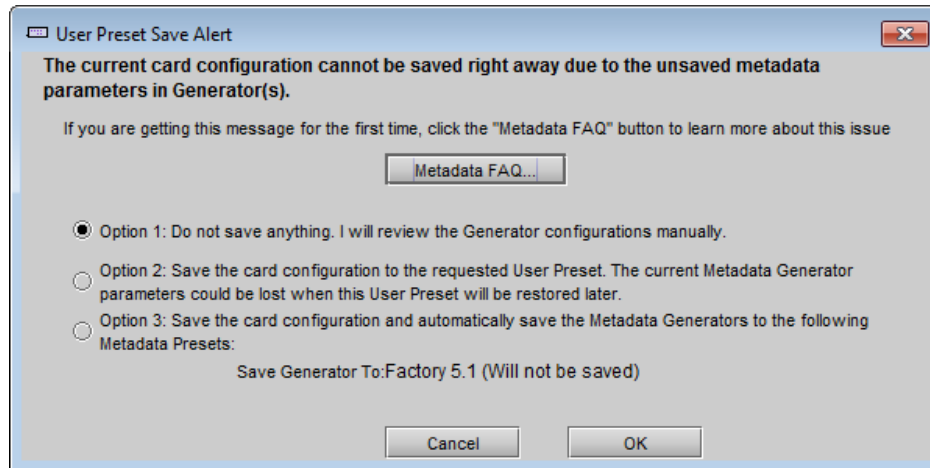

Figure 5.53 User Preset Save Alert warning panel

Briefly explained, a User Preset stores all the parameter values on the AMX-3981 card **except** the parameter values for the Metadata generators. These values are stored in a separate set of registers, and the User Preset saves the contents of these registers plus a pointer to the register that was most recently used. If you change any of the Metadata values but do not update the Metadata register by saving it, the values referenced by the pointer are not the current values. If you save to a user preset under this circumstance, the User Preset will not contain the changed values, and they cannot be recovered if you later load the card from the preset.

The **User Preset Save Alert** panel will be triggered any time you attempt to save when the Generator Metadata values have been changed but not saved. You can tell when this is the case, as both the User Preset box on the main panel, and the Current Generator Preset box in the Presets tab, as well as the Generator tab label, will all read *Custom*



How to tell when the metadata generator settings have not been saved

The warning box gives you three options for dealing with the situation:

- Option 1 – abort the save process, so that you can go back and manually save the metadata parameters (see instructions on page 50)
- Option 2 – go ahead and save anyway, but be aware that if you recall this User Preset you will probably not restore the current metadata generator settings
- Option 3 – Save the Metadata presets first, in the Metadata register whose name is displayed (it will be last register that was used, and if it is one of the factory registers a Save will not be allowed, so you might want to consider option 1), and then save the User Preset.

Use the radio buttons to select one of these options (option 1 is the default), and click OK to proceed.

Edit Presets Label...

Click this button to open a window where you can define the name assigned to each user preset. This is the name that will appear on the pull-down in the User Presets section. The labels will also be copied from card to card when a copy profile is performed.

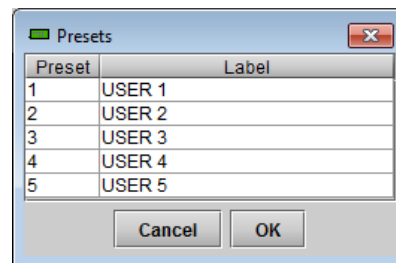

Profiles

This section provides the option to save and recover the entire card configuration (including user presets if desired) on an external disk, or to copy it to another AMX-3981 card.

Click on *Profiles* to open the Profile Copy window.

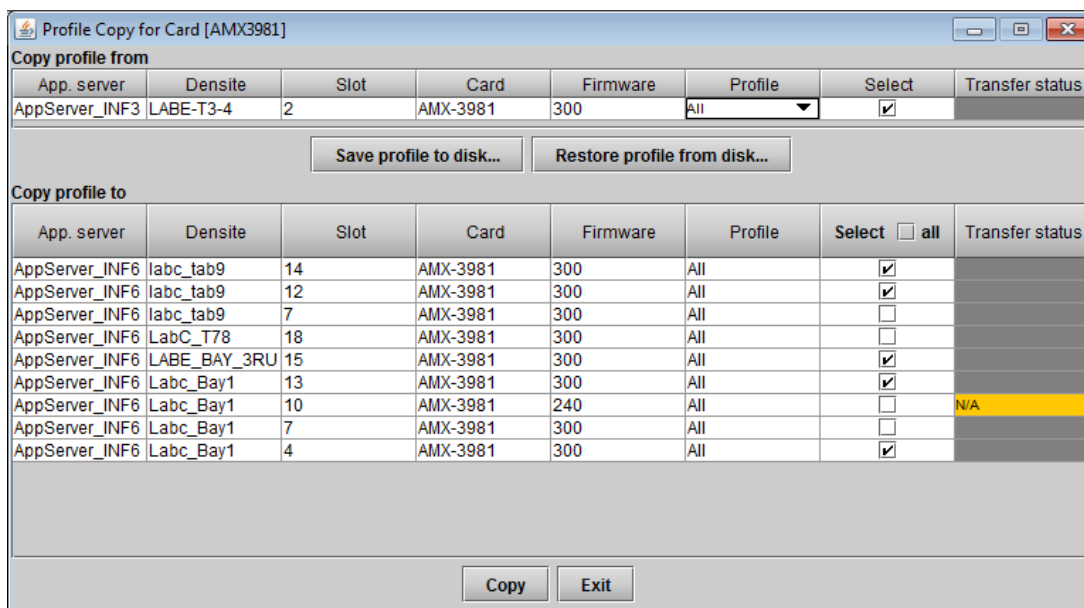

Figure 5.54 Profile Copy window

Copy profile from

This line shows this AMX-3981 card, and identifies it by App server, Densité frame and slot number, card type and firmware version.

The *Profile* column has a pull-down that allows you to select which profiles you will work with, and gives these choices:

- Current, User1, User2, User3, User4, User5, All

The *Select* column includes a checkbox (preselected checked) to confirm that you want to work with the current card.

Save Profile to Disk...

Click this button to open a Save dialog allowing you to specify a file name and location to which the selected profiles for this card will be saved.

Hint - It is a good idea to create a folder for these files, because they are not explicitly identified as AMX-3981 profiles, and will be difficult to find and identify if not clearly named and conveniently located.

- Click the save button once the name and location have been identified in the Save box
- If the file is saved correctly, the Transfer Status box on the right of the *Copy profile from* line will indicate *Succeeded* against a green background:

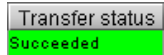

- If the file was not saved for some reason, the Transfer Status box to the right of the *Copy profile from* line will indicate *Failed* against a red background:

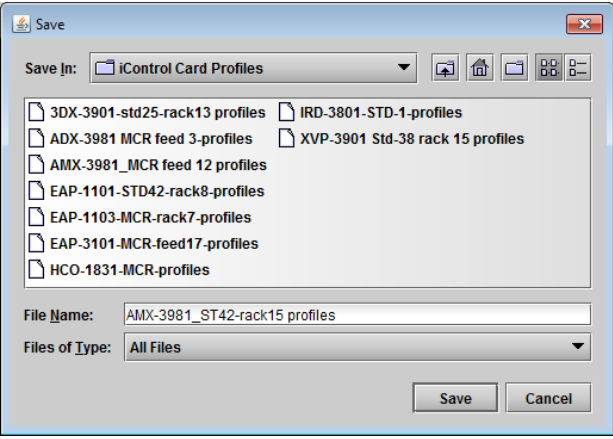
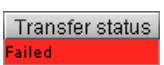

Figure 5.55 Save Profile to Disk dialog

Restore profiles from disk...

Click this button to open an *Open* dialog box within which you can locate and select a valid AMX-3981 profile file.

- Click Open to read the contents of the file and to reconfigure this AMX-3981's profiles according to its contents
- While the reconfiguration is in progress, the Transfer Status box on the right of the *Copy profile from* line will indicate *Working* against a yellow background
- When the reconfiguration is complete, the Transfer Status box on the right of the *Copy profile from* line will indicate *Succeeded* against a green background

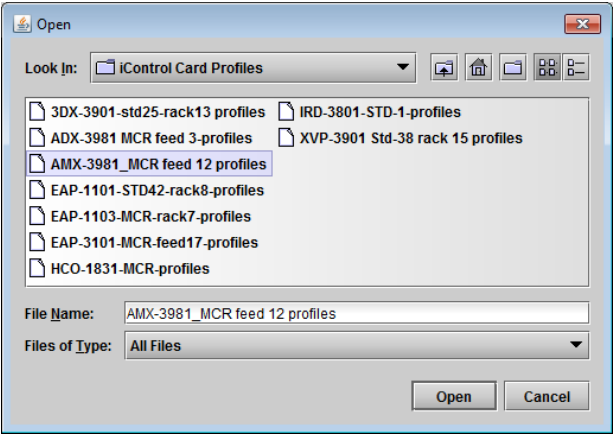

Figure 5.56 Restore Profiles from Disk dialog

Copy profile to

This line shows other AMX-3981 cards that are available on the iControl network, each identified by App server, Densité frame and slot number, card type and firmware version.

The *Profile* column shows the same information as is shown for the current card in the *Copy profile from* line, i.e. one of the following:

- Current, User1, User2, User3, User4, User5, All

The *Select* column includes a checkbox to identify the AMX-3981 cards onto which you will copy profiles from the current card.

- For convenience, a *Select all* checkbox is provided in the column header
- Note that you can only select AMX-3981 cards with the same firmware version as the source card; cards with a different firmware version will show N/A against a yellow background in the *Transfer Status* column.

Click *Copy* to copy the selected profiles from this card into the selected other AMX-3981 cards

- While the profile copy operation is in progress, the Transfer Status box on the right of the *Copy profile to* line will indicate *Working* against a yellow background
- When the profile copy operation is complete, the Transfer Status box on the right of the *Copy profile to* line will indicate *Succeeded* against a green background

5.15.2 Automatic Preset Recall tab

AMX-3981 offers the user the possibility to select a user preset based on the status of the incoming audio.

Access to the User1 and User2 presets can be triggered automatically when specific combinations of input audio signals are detected at the AMX-3981 input.

Switching card parameters in mid-program is more complex than switching them manually in an off-line situation because of the need to minimize or eliminate any transition effects, and is generally quite specific to the card configuration and the audio modules that are installed. Because of this, a fully automatic configuration of the feature is not possible, and user involvement is required. Set-up instructions are given below.

The Automatic Preset Recall (APR) feature uses the status of audio appearing at the input audio channels to determine whether activation of a preset is required.

The user selects whether to use the 16 embedded audio channels, or the 8 discrete AES audios in the process, using the radio buttons in the *Input Audio Selection* section of the panel.

The user specifies the combination of audios that must appear on all 16 channels using a concise Presence/Type string notation in a data box, one for each of the two user presets.

- For reference, the current input Presence/Type string is shown in a data box.
- The current input status for each channel is also displayed in a color and text graphic.

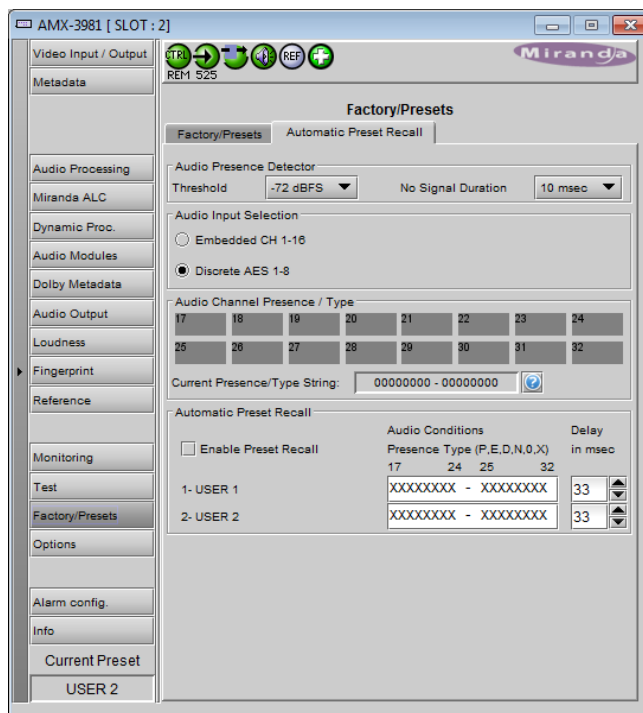
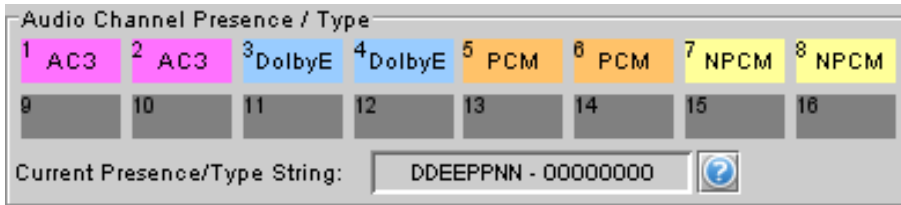

Figure 5.57 Automatic Preset Recall tab



The display and string notation used in the iControl panel is as follows:

Audio Type	Audio Channel Presence/Type Graphic		Presence/Type string character
	Label	Color Code	
Audio Not Present	(blank)	Dark Gray	0
PCM	PCM	Orange	P
Non-PCM	NPCM	Yellow	N
Dolby E	DolbyE	Blue	E
Dolby Digital	AC3	Fuchsia	D
Dolby Digital Plus	NPCM	Yellow	N
Don't Care	(only in string)	(only in string)	X

Audio Presence Detector section

Implementing this feature requires the use of an audio presence detector, since *Audio Not Present* is one of the parameters used in the detection process. This is not the same as an audio silence detector, which finds quiet portions in a present audio signal (the AMX-3981’s silence detectors are set up in the Audio Processing panel).

Use the *Threshold* pulldown to set the level (in dBFS) below which the AMX-3981 will consider the audio to be absent.

Range: -72 (default), -66, -60, -54, -48

Use the *No Signal Duration* pulldown to set the time interval for which the audio must be continuously detected as absent before the Signal Absent status will be confirmed and active.

Range: 33 msec (default), to 100 msec in steps of 10 msec.

Automatic Preset Recall section

To activate this feature, click Enable Preset Recall

- Always configure the User Presets 1 & 2 before activating this feature, as the card will try to reload the previously saved presets every time you try to change the card’s configuration. First, uncheck Enable Preset Recall, configure the card according to the first preset, save it and then proceed the same way for the second preset. Finally, enable the Automatic Preset Recall by checking the Enable Preset Recall.
- Note that you may activate either *Automatic Preset Recall* as described here, or select a user preset to be activated by a GPI in the *Load Presets* section of the Metadata | GPI tab (see section **Error! Reference source not found.** on page **Error! Bookmark not defined.**), but only one of these may be active at a time. If User Preset activation via GPI is active when you click Enable Preset Recall in this tab, a warning box will appear to remind you that enabling this function here will disable the User Preset activation via GPI, and give you the choice to proceed, or to cancel the selection.

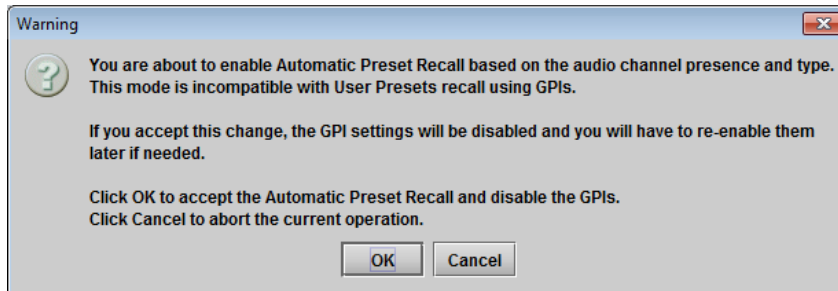

Figure 5.58 Presets selection warning

Audio Conditions – type a Presence/Type string into the data box for each of the presets that you wish to recall automatically. Priority will be given to the first condition (USER 1). For example, if you want to do something when 5.1 audio is detected and something else when it is not detected, define the audio condition for 5.1 as the first condition.

The string represents the input configuration that will trigger the preset.

- A useful way to determine the appropriate entry is to set up the inputs to the configuration of interest, and then copy the string that appears in the Current Presence/Type String data box into the User Preset data box. Note that unused channels should be set to 'X' (don't care) rather than 0 (absent).

While you are typing, note that:

- Only the characters that are significant can be typed; other keystrokes have no effect
- Characters are not case sensitive, although they appear as capitals in the databox.
- Click and drag to select one or more characters to type
- If you stop typing before filling all the selected character spaces, all remaining spaces will be filled with X (i.e. don't care) once you move the focus away from the box.
- The AMX-3981 will automatically detect conflicts, i.e. audio conditions that could call both presets simultaneously. This could arise because of Don't Care situations, or because the same string was accidentally entered in both preset boxes. The most recently entered string will appear in red and will not be active. In case of conflicts, the User Preset 1 condition will have priority.

Delay – set the delay between the detection of the condition that triggers the loading of a preset, and the actual execution of the preset.

- The range in the scroll box is from 0 msec up to 500 msec, continuously variable.
- For AMX-3981, the default value is 33 msec, but the optimum value really depends on the application.

The Delay parameter is used to delay the loading of a User Preset into the card's hardware. The delay range will be from the fastest audio condition detection time to the longest processing delay of the card.

To begin, note that the Audio Type detector and the Audio Presence detector are both located at the input to the card:

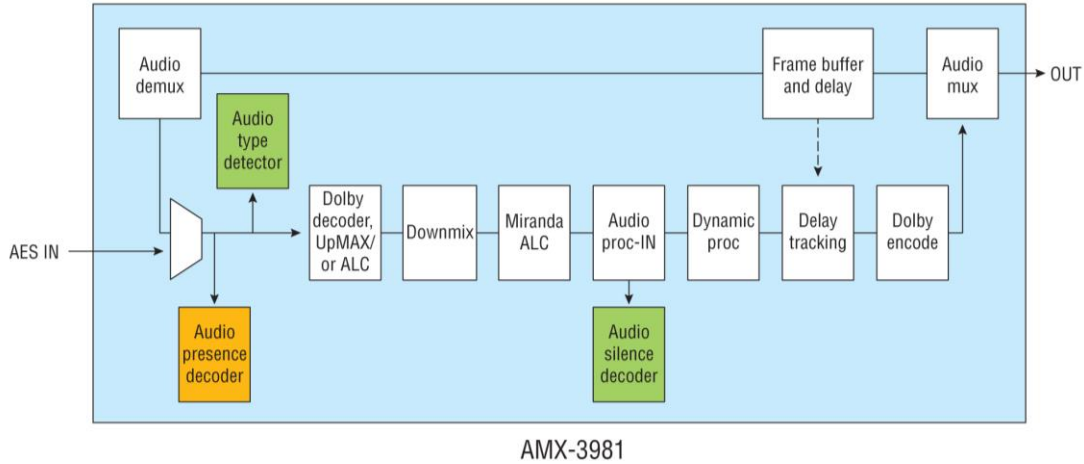

Figure 5.59 Relative position of audio presence and type detectors

The idea is to calculate the time delay as the audio passes through the AMX-3981 between the time at which the audio condition is detected, and the time when the audio arrives at the location where the changes in processing need to be applied. The new preset should only be applied then, so that the processing change is applied only to the new audio type.

Each card preset may contain hundreds of parameters: some are used to configure input parameters and others output parameters. Unfortunately, all changes are applied more or less at one time, so some compromise is often required when processing delays through the card are relatively long, such as in Dolby Digital and Dolby Digital Plus encoding applications. Understanding what processing changes are required, and where those changes are applied in the signal path through the AMX-3981, will help in making the most effective choice of delay time.

Most of the time, the different presets are nearly identical and only a few parameters will change from one preset to another. Obviously, if the preset needs to control input and output parameters at the same time, it will be impossible to select a perfect Delay.

Application for the Automatic Preset Recall:

Figure 5.60 shows the application. When DV is present on embedded input channels 7-8, it is passed to the output. When not present, a downmix version of the main 5.1 will be used. It has been determined by the customer that the audio level on the DV channels is always above -72 dBFS because of the noise floor. If it goes below that threshold, we can assume there is no audio present.

User Preset 1 will be recalled when DV is present on the embedded audio input channels 7-8. The embedded audio output shuffler for channels 7-8 will be programmed to pass the input channels 7-8.

User Preset 2 will be recalled when DV is silent on the embedded audio input channels 7-8. The embedded audio output shuffler for channels 7-8 will be programmed to pass the output downmix channels 15-16 made from channels 1-6.

The No Signal Duration will be set to 30 msec and the Threshold to -72 dBFS. Assuming the total processing delay of the AMX-3981 is set to 66 msec to give enough reaction time between the detection of the silence and the application of the preset, the Automatic Preset Recall should be configured as shown in the picture below:

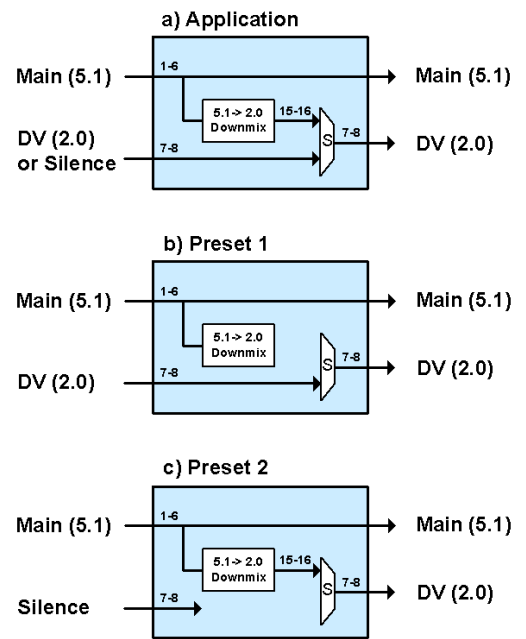

Figure 5.60 Application for automatic preset recall

Audio Presence Detector		
Threshold	-72 dBFS	No Signal Duration
	30 msec	
Automatic Preset Recall		
<input checked="" type="checkbox"/> Enable Preset Recall	Audio Conditions	Delay
	Presence/Type (P,E,D,N,0,X)	in msec
	1 8 9 16	
1- USER1 (Late Night Show)	XXXXXXXXPP - XXXXXXXX	8
2- USER2 (Network 2.0)	XXXXXXXX00 - XXXXXXXX	10

The delay to apply the preset has been optimized to take into account the No signal Duration, the total processing delay of the card and the internal reaction times of the card. Determining the accurate preset Delay to apply is rather complicated. Please contact our Technical Support department if you experience any difficulties.

5.16 Options panel

Two options are available for the AMX-3981:

- Dynamic Processing Option (AMX-3981-OPT-DP)
- ALC Option (AMX-3981-OPT-ALC-X)

To activate each of these options, you must

- Obtain a license key from Grass Valley.
- Type the license key in the *Enter Key* box
- Click on ENABLE OPTION to enable the option’s features.

5.16.1 Dynamic Processing option:

This option enables the audio dynamics processing functionality of the AMX-3981.



Figure 5.61 Dynamic Processing option

5.16.2 ALC option

This option enables the Automatic Loudness Control feature of the AMX-3981.

Note that this option is available for 2, 6, 8 or 16 channels.

A separate license key is required for each of these, and the data window below the *Enter key* data box will indicate which is currently enabled, e.g.:

ALC AMX-3981-OPT-ALC-16 for the 16 channel option

If the currently-enabled option is 2, 6, or 8 channels, the *Enter key* data box will be available to upgrade to a greater number of channels.

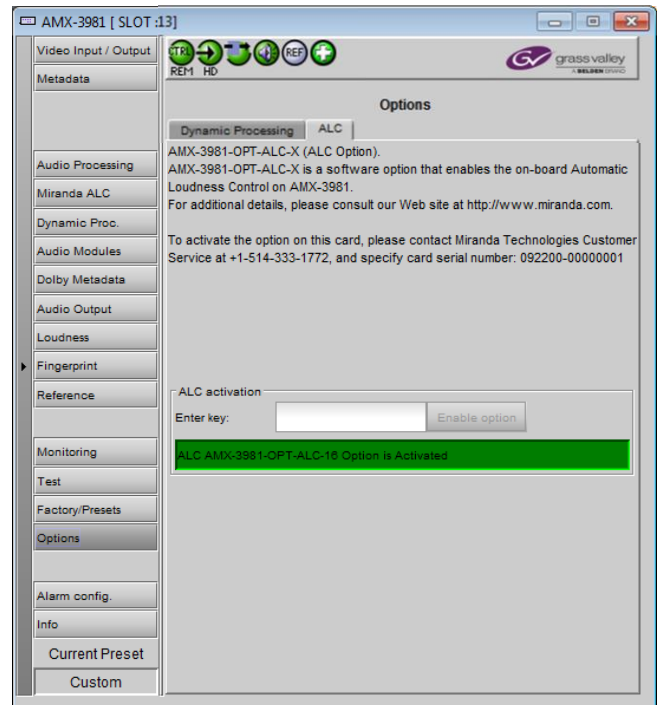

Figure 5.62 ALC option

5.17 Alarm Config panel

This panel allows the alarm reporting of the AMX-1981 to be configured. The panel opens in a new window when the button is clicked, and can be resized if needed.

The panel is organized in columns.

Status/Name

This contains an expandable tree listing all the alarms reported by this AMX-3981 card.

- Each alarm name includes an icon that shows its current status
- Some alarms may be text-only and the alarm status is shown in the name and not by a status icon

The **Card LED**, **Overall alarm** and **GSM contribution** columns contain pulldown lists that allow the level of contribution of each individual alarm to the alarm named in the column heading to be set.

- If there is no arrowhead in the box, there is no pulldown and the alarm is not user-configurable

Card LED

This column allows configuration of the contribution of selected individual alarms to the status LED located on the front card edge. The Card LED status is shown at the bottom of the alarm tree in the Status/Name column.

Overall Alarm

This column allows configuration of the contribution of each individual alarm to the Overall Alarm associated with this card. The Overall Alarm is shown in the upper left corner of the iControl panel, and also appears at the bottom of the Status/Name column.

GSM Contribution

This column allows configuration of the contribution of each individual alarm to the GSM Alarm Status associated with this card. GSM is a dynamic register of all iControl system alarms, and is also an alarm provider for external applications. The possible values for this contribution are related to the Overall alarm contribution:

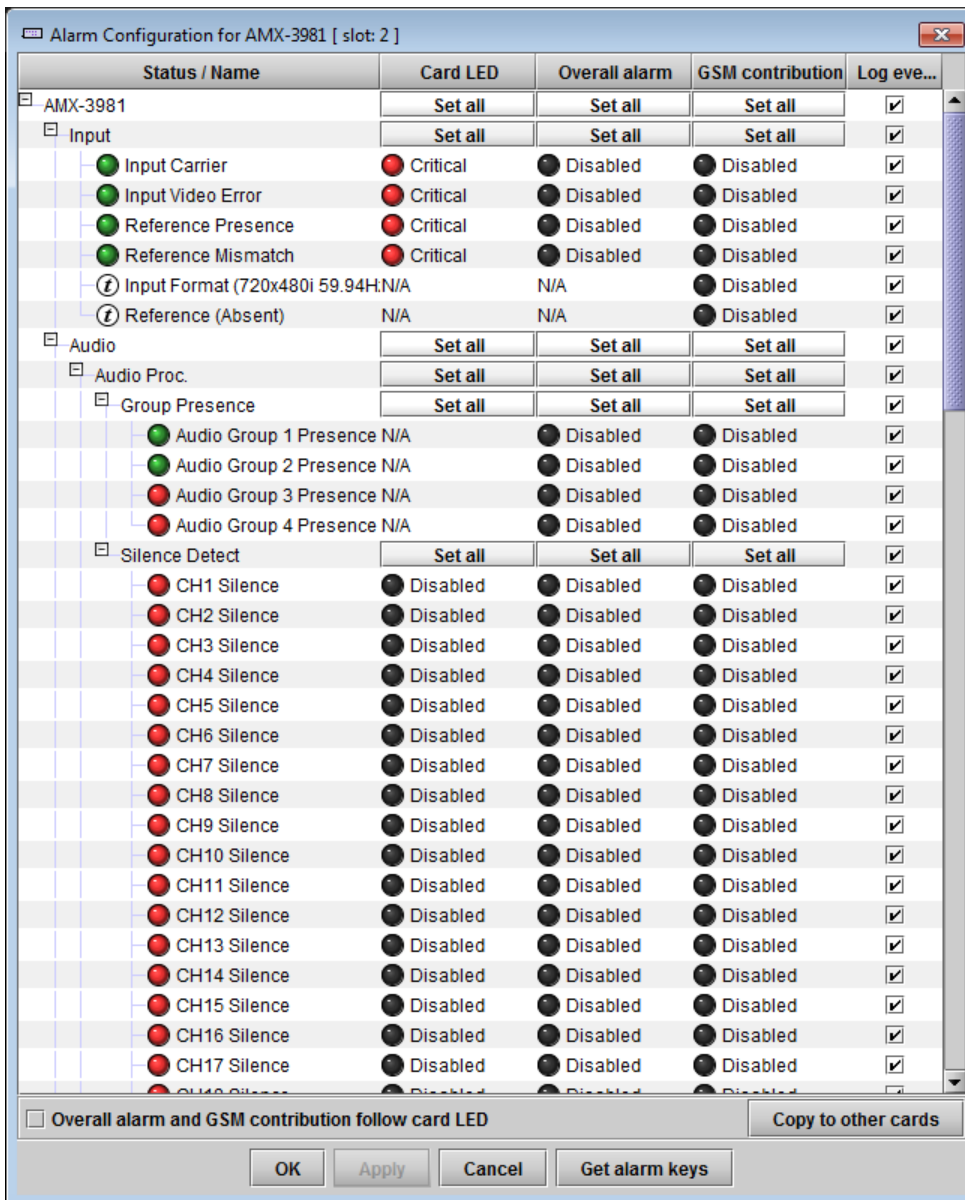







Figure 5.63 Alarm Configuration panel

- If the Overall alarm contribution is selected as Disabled, the GSM alarm contribution can be set to any available value
- If the Overall alarm contribution is selected as any level other than disabled, the GSM contribution is forced to follow the Overall Alarm.

Levels associated with these alarms:

The pulldown lists may contain some or all of the following options:

-  Disabled The alarm makes no contribution (black icon)
-  Minor The alarm is of minor importance (yellow icon)
-  Major The alarm is of major importance (orange icon)
-  Critical The alarm is of critical importance (red icon)
-  Passthrough The alarm exists but has no effect (used for text and composite alarms)

Shortcut: if you click in one of the Set All boxes beside a section heading, you will open a pulldown that lets you assign a level to all alarms in that section of the column simultaneously.

Once the alarms are configured, you may accept the changes or discard them:

Log Events

iControl maintains a log of alarm events associated with the card. The log is useful for troubleshooting and identifying event sequences. Click in the checkbox to enable logging of alarm events for each individual alarm.

At the bottom of the window are several other controls

Overall alarm and GSM contribution follow card LED

Click in the checkbox to force the Overall alarm and GSM contribution to be identical to the Card LED status

- All Overall alarms and GSM contributions for which there is a Card LED alarm will be forced to match the Card LED alarm
- All Overall Alarms and GSM contributions for which there is no Card LED alarm will be forced to Disabled

A warning box will open allowing you to confirm the action, since it will result in changes to the configuration and there is no *undo* function.

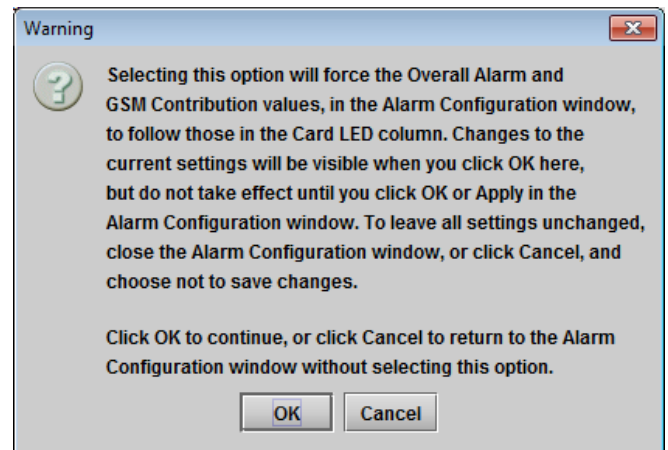

Figure 5.64 Warning for Follow LED change

Copy to other cards

Click this button to open a panel that allows the alarm configuration set for this card to be copied into another AMX-3981 card.

- Select one or more destination cards from the list in the window by clicking in the checkboxes, or all of them by clicking in the *All* checkbox
- Note that when you do a Copy Profile for this card (see Sect.5.15), the alarm configuration is copied along with all the other settings.

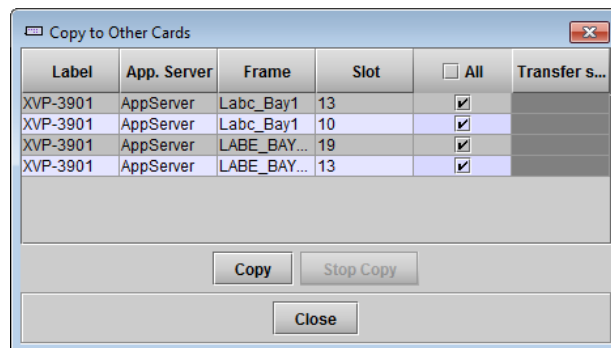

Figure 5.65 Copy to Other Cards window

Get alarm keys

Click this button to open a save dialog where you can save a file containing a list of all alarms on this card and their current values, along with an Alarm Key for each. The alarm keys are useful for system integration and troubleshooting.

- The file is saved in .csv format

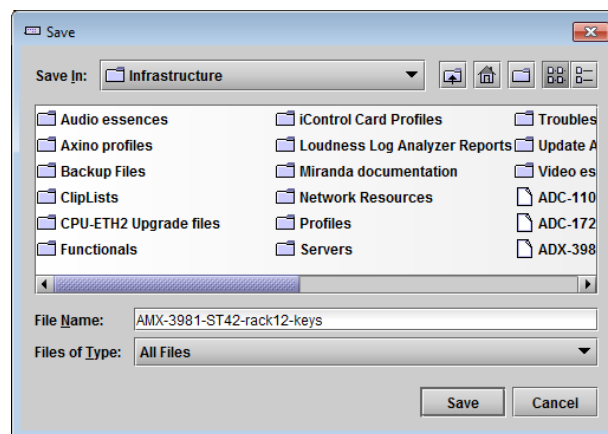

Figure 5.66 Get Alarm Keys dialog

OK, Apply, Cancel

- **OK** accepts the settings and closes the window once the card confirms that there are no errors.
- **Apply** accepts the settings, but leaves the window open
- **Cancel** closes the window without applying any changes, and leaves the previous settings intact.

5.18 Info panel

When the AMX-3981 is included in an iControl environment, certain information about the card should be available to the iControl system. The user can enter labels and comments that will make this card easy to identify in a complex setup. This information is entered into data boxes in the Info control panel.

- Rear Type: specifies the rear module currently installed.
- Optic Fiber Module: Identifies the optic fiber module currently inserted in the fiber module socket on the rear panel (only if installed).
- Audio Module: Identifies the audio module currently installed on the AMX-3981, if any.
- Label: type the label that is shown for this AMX-3981 when it appears in iControl applications
- Short Label type the short-form label that iControl uses in some cases (8 characters)
- Source ID type a descriptive name for this AMX-3981
- Comments: type any desired text

The remaining data boxes show manufacturing information about this card.

Three buttons in the panel give access to other information.

- Details...: Reports the Firmware version, service version, and panel version for this card

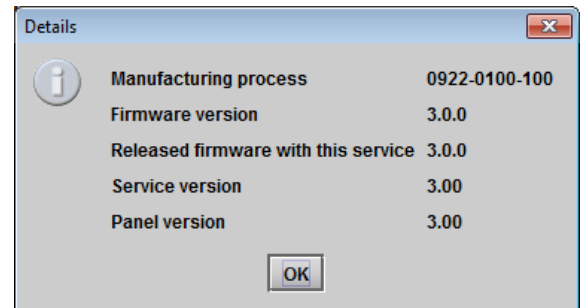

Figure 5.68 Details window

- Advanced...: Shows the LongID for this card. The LongID is the address of this AMX-3981 in the iControl network.

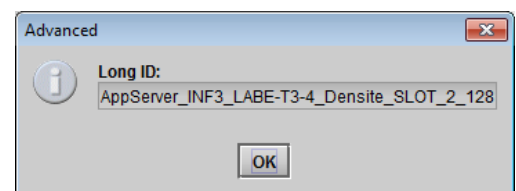

Figure 5.69 Advanced window

- Remote System Administration – opens the Joining Locators window, which lists remote lookup services to which this AMX-3981 is registered

Add: Force the iControl service for this AMX-3981 to register itself on a user-specified Jini lookup service, using the following syntax in the data box:

jini://<ip_address>

where <ip_address> is the ip address of the server running the lookup service, e.g.:

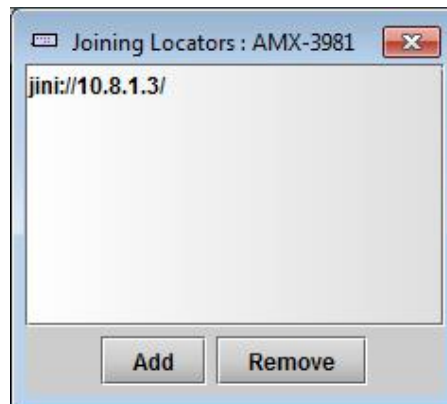
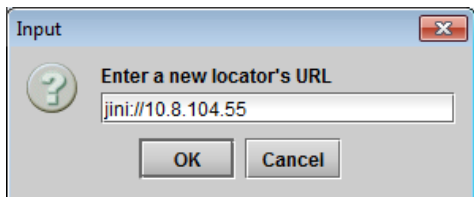
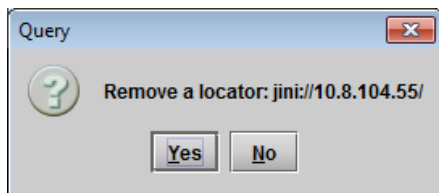

Figure 5.70 Joining Locators window

Remove: select one of the services listed in the window by clicking on it, and click *Remove* to open a query box allowing you to delete it from the window.



6 Audio Modules

The AMX-3981 supports the use of a single audio processing module, user-installed into a socket on the main circuit board.

- See Annex 4 beginning on page 104 for a description of the module installation and removal procedure

A number of different modules are available, allowing the functionality of the AMX-3981 to be customized. This section of the manual describes each of the available modules in detail.

Module	Description	See section
MOD-DOLBY-DEC-2	Dolby E and Dolby Digital decoder	6.1 on page 79
MOD-DOLBY-ENC-D-2	Dolby Digital and Dolby Digital Plus encoder	6.2 on page 82
MOD-DOLBY-ENC-E	Dolby E encoder	6.3 on page 84
MOD-LA-DUP-701	Upmixing using Linear Acoustic Technology upMAX™	6.4 on page 85
MOD-LA-ALC-N*	N-channel ALC licensed by Linear Acoustic	6.5 on page 87
MOD-LA-ALC-N*-DUP	N-channel ALC and upmix licensed by Linear Acoustic	

* N = 2, 6 or 8, referring to the number of channels processed.

6.1 Dolby E and Dolby Digital decoder

- Identified as MOD-DOLBY-DEC-2 on the module tab.

The decoder supports Dolby E, Dolby Digital or PCM signals. Any other non-PCM signal will be lost through the decoder module; its outputs will be muted.

For a Dolby E input signal, the decoder outputs a metadata bitstream which may be used by the audio processing and the audio modules, embedded in the 3G/HD and SD outputs, or sent to the RS-422 output. See the Dolby Metadata tab.

A selector is provided at the Decoder input, but the output channels of the Decoder are routed to the internal channels 1-8, 9-16, 17 to 24, or 25-32, with a mapping related to the input Program Configuration and Coding Mode.

6.1.1 Control tab

The **Bitstream Detection Mode** dictates the action taken by the decoder for each type of input bitstream.

In **Auto** mode, the decoder automatically recognizes and decodes PCM, Dolby Digital or Dolby E input bitstreams. If **Dolby E only** is selected, the decoder recognizes and decodes only Dolby E bitstreams; otherwise the decoder outputs are muted. The same behavior applies for the **Dolby Digital only** selection. If **Mute (OFF)** is selected, all outputs are muted for any type of input bitstreams; the Mute mode disables the Dolby decoder.

The **Input Selection** determines the Dolby decoder input channel pair. See **Audio Processing/AES Inputs** for the input selection from the audio card.



Figure 6.1 Audio Modules - Dolby E and Dolby Digital Decoder - Control

The **Decoder Status** section indicates the bitstream format detected at the decoder input. The possible values are: Dolby E (16, 20 or 24 bits), Dolby Digital (16 or 32 bits, Channel 1, 2 or both), PCM. The detected Dolby format will give access to the corresponding tab in the row beside the Control tab.

The **Dolby Digital** section at the bottom of the tab is available only if the input bitstream is Dolby Digital, and the Detection Mode is Dolby Digital or Auto.

- Refer to ANNEX 5 at the end of this document: Dolby Digital Main Channel Output Functions.

The **Stream Select** parameter selects the stream number to be decoded when multiple Dolby Digital bitstreams are embedded within a single channel pair.

The **AES Channel Select** parameter selects which AES3 channel is the source of the Dolby Digital decoder if the Dolby Digital data is configured in Professional 16-bit format. If the selected channel does not contain a valid Dolby Digital bitstream, the channel data will be passed to the decoder output as a PCM signal.

The **Listening Mode** parameter selects the main channel output listening mode. It is active only for a Dolby Digital input signal.

- **Full** is the standard mode.
- Monitoring in **3 Stereo** mode reproduces only the left, right and center channels, the surround channels are muted.
- In **Phantom** mode, the center channel output is muted.
- The **Stereo** mode will output only on the left and right channels, and the **Mono** mode only on center channel.
- Refer to ANNEX 5 at the end of this document: Dolby Digital Main Channel Output Functions.

6.1.2 Dolby E tab

The **Dolby E** tab indicates status information for the selected Dolby E bitstream.

The **Dolby E Common Status** section shows two values that are common to all programs contained in the Dolby E bitstream: **Program Configuration** and **Frame Rate**.

The **Decoder to Proc Channel Assignment** section gives the decoder output mapping to the internal channels of the AMX-3981.

- The **Main Output** sub-section shows channel assignments related to the Program Configuration.

The **Prg 1** to **Prg 8** sub-tabs indicate Metadata information associated with each Dolby E program: **Coding Mode**, **Bitstream Mode**, **Dialnorm** (dialog normalization) value, **Line Mode Profile**, **RF Mode Profile**, **Dolby Surround Mode**, **Surround EX Mode** and **Preferred Stereo Downmix**. The number of programs depends on the Program Configuration.

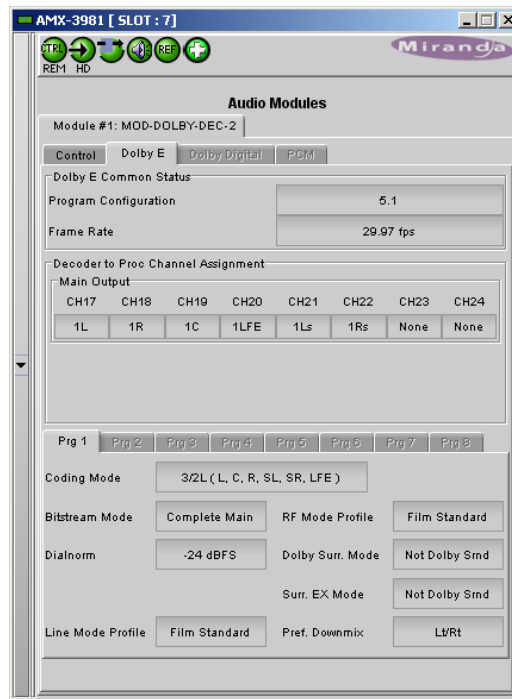

Figure 6.2 Dolby E and Dolby Digital decoder - Dolby E tab

6.1.3 Dolby Digital tab

The **Decoder to Proc Channel Assignment** section indicates the output channel assignment. The Main Output sub-section shows channels assignment related to the Program Configuration.

The **Dolby Digital Status** section indicates status information for the Dolby Digital bitstream selected at the bottom of the **Control** tab:

- Coding Mode
- Data Rate
- Bitstream Mode
- Dialnorm value
- Dolby Surround Mode
- Surround EX Mode
- Preferred Stereo Downmix Mode.

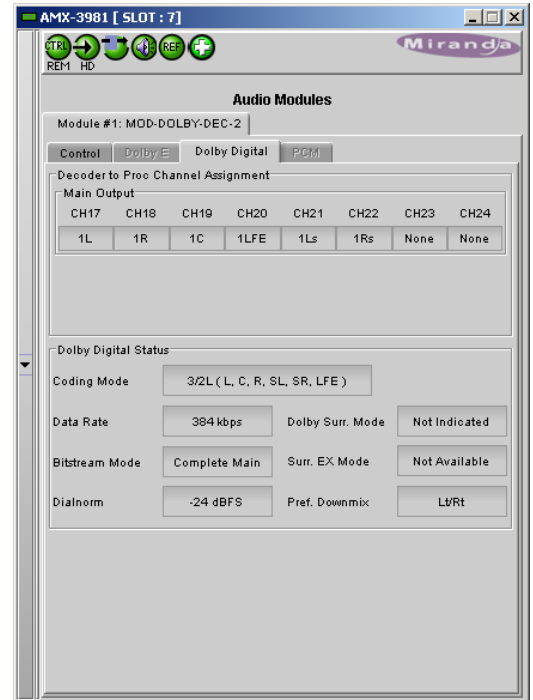

Figure 6.3 Dolby E and Dolby Digital decoder - Dolby Digital tab

6.1.4 PCM tab

The **PCM** tab section indicates the output audio assignment of the Dolby Decoder module when its input is a PCM signal.

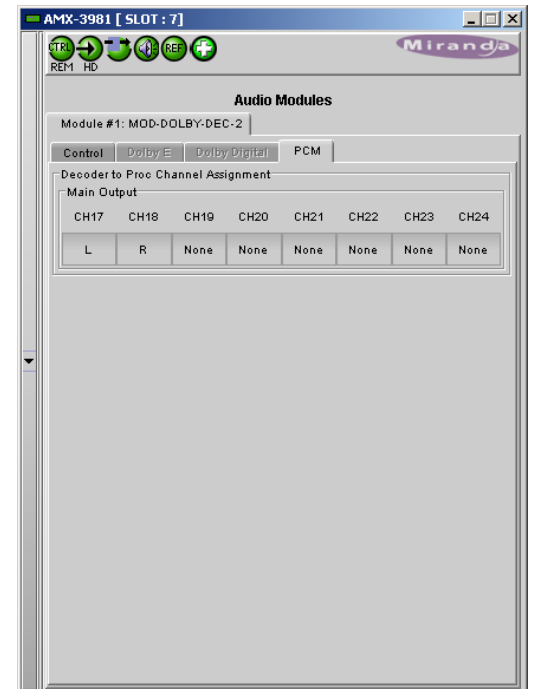

Figure 6.4 Dolby E and Dolby Digital decoder - PCM tab

6.2 Dolby Digital and Dolby Digital Plus encoder

- Identified as MOD-DOLBY-ENC-D-2 on the module tab. The Dolby Digital Plus functionality is available in module version 5.1.0.0 and higher (version number shown in the upper right corner of the tab).

6.2.1 Shuffler Inputs

An input shuffler allows any combination of the input channels (default are CH1 to CH6). The input labeling will follow the Metadata (Coding Mode parameter for the selected Program).

- Pull-downs: Available input channels 1 to 32

The graphic shows the output channels in use.

Output Channels

Use the pull-down to select the pair of channels on which the encoded output will be placed.

[1-2, 9-10, 17-18, 25-26]

Dolby Digital Plus

Select the checkbox to activate Dolby Digital Plus encoding instead of Dolby Digital. Available in module version 5.1.0.0 and higher.

6.2.2 Configuration

Encoder Control

Use the pull-down to select the operational mode: **Dolby Digital Encode** or **Dolby Digital Plus Encode** (as selected using the *Dolby Digital Plus* checkbox) or **Pass-through**.

Test signals at -18, -20 dBFS and silence are available for each mode.

- Encode** test modes will generate a test bit-stream containing a 1 kHz sine wave for full bandwidth channels and 100 Hz for the LFE channel of a 5.1 program.
- In **Pass-through** test modes, it will generate a 1 kHz PCM sine wave at its outputs.

When the encoding mode changes, the output mutes and resumes in the selected mode within one second.

Data Rate

The card can encode at all Dolby Digital data rates between 56 kbps and 640 kbps and all Dolby Digital Plus data rates between 32 kbps and 1024 kbps, although there are constraints in regards to data rate versus channel configuration (audio coding mode) – see Table 1.

It supports automatic switching of the data rate based on the *Coding Mode*.

Stream Number

Sets the output stream number from 0 to 6.

Bitstream Format

The output mode of the Dolby Digital bit-stream can be set to 32-bit, 16-bit Channel 1 or 16-bit channel 2. The default setting is 32-bit. The output mode of Dolby Digital Plus is always 32-bit.

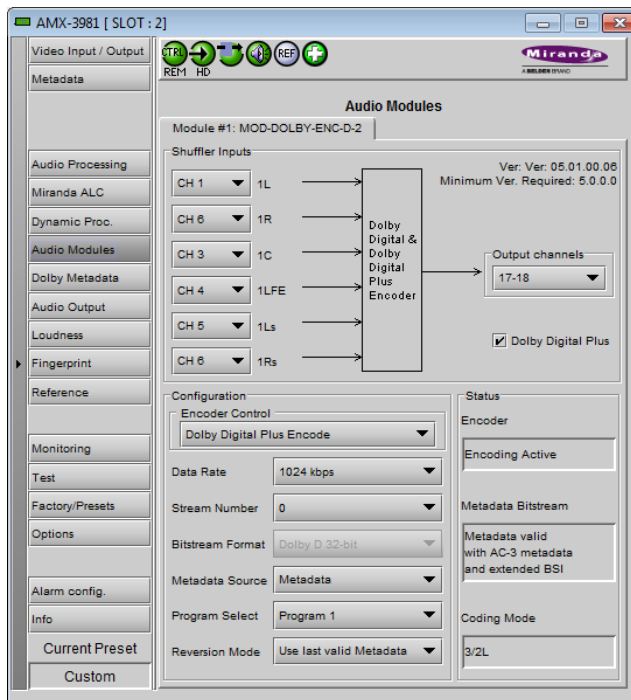

Figure 6.5 Audio Module - Dolby Digital and Dolby Digital Plus Encoder

Metadata Source

Selects the Metadata Path set up in the **Dolby Metadata tab** (see section 5.8 beginning on page 44)

Program Select

Selects the Metadata Program used for encoding. Refer to **Dolby Metadata tab** to access settings.

[Program 1, Program 2, Program 3, Program 4, Program 5, Program 6, Program 7, Program 8]

Reversion Mode

This parameter specifies the module’s behavior when its selected **Metadata Source** is lost or corrupted.

[Use last valid Metadata, Stop Encoding]

Encoding Latency

The Dolby Digital and Dolby Digital Plus encoding latency is 187 msec. The encoding latency is automatically compensated (to avoid lip-sync issues) when the video frame delay (**Timing tab**) is set to at least seven (7) frames for 59.94 Hz formats and at least six (6) frames for 50 Hz formats.

Table 1: Auto Data Rate Assignment

Coding Mode	Dolby Digital Automatic 384	Dolby Digital Automatic 448	Dolby Digital Plus Automatic
1/0	96 kbps	96 kbps	64 kbps
2/0	192 kbps	256 kbps	128 kbps
2/1, 3/0	256 kbps	256 kbps	160 kbps
2/2, 3/1	320 kbps	320 kbps	192 kbps
3/2	384 kbps	448 kbps	192 kbps

6.2.3 Status:

Text boxes report current status for Encoder, Metadata bitstream and Coding Mode

Encoder

This box indicates the operational status of the encoder.

Metadata Bitstream

This box indicates the status of the selected Metadata bitstream. The Metadata will be reported as invalid if it contains missing and/or invalid parameters or erroneous segment checksums.

Coding Mode

This box indicates the Coding Mode parameter in the selected Metadata bitstream.

6.3 Dolby E encoder

- Identified as MOD-DOLBY-ENC-E on the Module tab

6.3.1 Input and Output channel selection

Shuffler Inputs

An input shuffler allows any combination of the available channels to be used as inputs. Default is CH1 to CH8.

- Pulldowns: Available input channels 1 to 32

Output Channels

Use the pulldown to select the pair of channels on which the encoded output will be placed.

[1-2, 9-10, 17-18, 25-26]

6.3.2 Configuration

Encoding Mode

The operational mode can be **Dolby E Encode** or **Pass-through**.

Test signals at -18, -20 dBFS and silence are available for each mode.

- Encode** test modes will generate a test bit-stream containing a 1 kHz sine wave for full bandwidth channels and 100 Hz for the LFE channel of a 5.1 program.
- In **Pass-through** test modes, it will generate a 1 kHz PCM sine wave at its outputs.

When the encoding mode changes, the output mutes and resumes in the selected mode within one second.

In both encoding and pass-through mode, the delay through the encoder is always one video frame.

Bit Depth

This parameter specifies the number of bits per word used in the Dolby E bitstream. When using an output data width of 16 bits, the available program configuration will be limited to those which require a maximum total of 6 channels.

48 kHz Pull-down

When Pull-down mode is enabled the encoder will output the Dolby E bitstream at a sample rate of $(1000/1001) * 48$ kHz.

Metadata Source

Metadata is the only option. Refer to the **Dolby Metadata** panel (section 5.8) for information and configuration.

Reversion Mode

This parameter specifies the module's behavior when its selected **Metadata Source** is lost or corrupted.

[Use last valid Metadata, Stop Encoding]

Note: With version 1.1.2.0 of the Dolby E encoder, the **Reversion Mode** is forced to **Use last valid Metadata** due to a limitation in the module itself. The **Stop Encoding** mode will be available in future versions of the encoder.

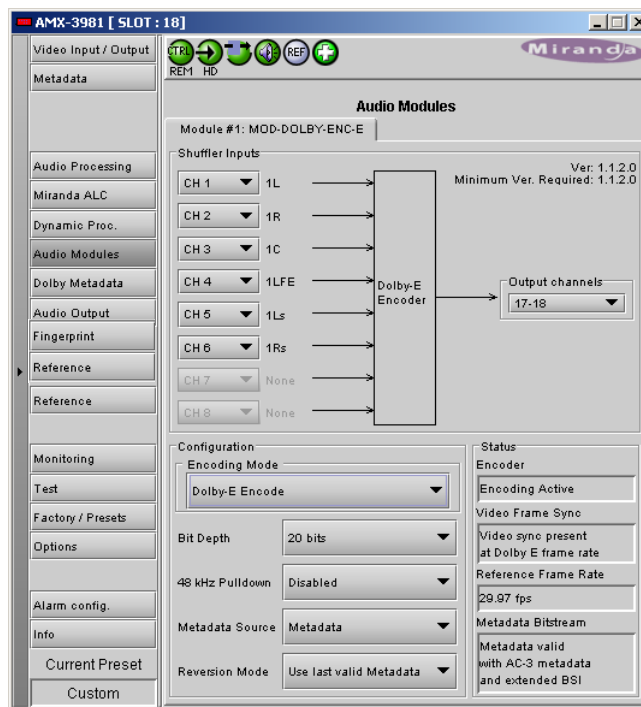

Figure 6.6 Audio Modules - Dolby E encoder

Encoding Latency

The Dolby E encoding latency is one (1) video frame (33 msec for 59.94 Hz formats and 40 msec for 50 Hz formats). The encoding latency is automatically compensated (to avoid lip-sync issues) when the video additional frame delay (**Timing** tab) is set to at least one (1) frame.

6.3.3 Status:

Text boxes report current status for Encoder, Video Frame Sync, Reference Frame Rate and Metadata bitstream.

Encoder

This parameter indicates the operational status of the encoder.

Video Frame Sync

This parameter indicates the status of the video reference signal provided to the encoder.

Reference Frame Rate

This parameter indicates the frame rate of the video reference signal provided to the encoder. It will be set to **Not Indicated** if the frame rate is not recognized.

Metadata Bitstream

This box indicates the status of the selected Metadata bitstream. The Metadata will be reported as invalid if it contains missing and/or invalid parameters or erroneous segment checksums

6.4 Upmixing using Linear Acoustic Technology upMAX™

- Identified as MOD-LA-DUP-701 on the module tab.

This optional module integrates the upMAX™ upmixer function licensed by Linear Acoustic. This processing creates a 5.1 channel surround field (Left, Right, Center, LFE, Left-Surround, Right-Surround) from a 2.0 channel stereo input (Left, Right)

The **Config - Mode** pull-down box offers four different processing solutions:

Pass Mode

Select the input channels to the L, R, C, LFE, Ls and Rs inputs with the pull-down menus. These channels are passed through unaltered and are assigned to the output channels selected using the Output Channels pull-down

Upmix Mode

Select the input channel pair to the L/R inputs with the pull-down menu. The resulting 5.1 channels are assigned to the output channels selected using the Output Channels pull-down.

AutoMAX-II™ Mode

Select the input channel pair to the L/R inputs with the pull-down menu. The resulting 5.1 channels are assigned to the output channels selected using the Output Channels pull-down. Additionally the channels selected at the C, LFE, Ls and Rs inputs are summed with the outputs of the upmixing process.

This mode also allows a 5.1 audio present at the input to pass through. It will auto switch between a stereo and a 5.1 audio source to provide a 5.1 output at all times.

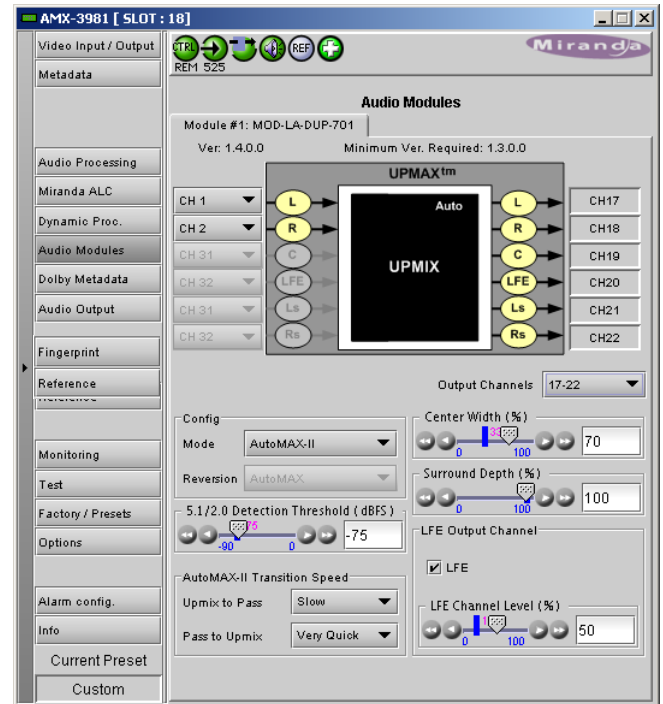

Figure 6.7 Audio Modules - Linear Acoustic UpMAX

- Set up the transition between the two modes to be unobtrusive by selecting transition speeds for each case – upmix-to-pass and pass-to-upmix – using the two AutoMAX-II Transition Speed pulldowns
- Use the 5.1/2.0 Detection Threshold slider to set the level at which some 5.1 channels are considered to be silent, identifying the input as 2.0

Note: The AutoMAX-II™ algorithm is supported by firmware version 1.3.1.0 and later. Firmware version 1.3.0.0 supports only the AutoMAX-I™ algorithm. The AutoMAX-I™ algorithm does not support the upmix-to-pass and pass-to-upmix transition speeds.

Follow Metadata mode

This mode may be useful for sources that switch between stereo and 5.1. The *Coding Mode* parameter in the first program of the Dolby metadata will set the Operating Mode between Pass and Upmix modes.

Note: In *Follow Metadata* mode, the metadata generator will be automatically turned ON when the upMAX™ module is upmixing to provide a valid metadata stream for the upmixed audio content. The generator content must have been previously configured with valid 5.1 metadata parameters. When the upMAX™ module is set to *Pass* mode by the incoming metadata stream, the generator will be automatically turned OFF to let the incoming metadata stream pass through. Refer to *Generator Automated* mode in the Dolby metadata panel section for further details.

If the *Coding Mode* parameter (in the Dolby Metadata panel) is other than 3/2 (i.e. 5.1 channels) or 2/0 (i.e. stereo channels) or if the selected metadata path does not carry metadata, the Operating mode will follow the Reversion Mode pull-down.

Coding Mode (Metadata):	Operating Mode:
3/2	PASS
2/0	UPMIX
1+1, 1/0, 3/0, 2/1, 3/1, 2/2, or metadata is not present	Reversion Mode

The **Reversion Mode** pull-down sets the default Operating Mode to: Pass, Upmix, Last Valid (Last valid *Coding Mode*), AutoMAX.

Adjustments

The “surround field” can be adjusted with the Center channel Width control and the Surround channel Depth control.

The bass enhancement signal for the LFE channel is derived from the Left, Center and Right channels. The LFE checkbox and LFE Channel Level (%) slider control the LFE output.

Latency

The upMAX™ processing latency is automatically compensated by the card.

Note: when in UPMIX and AUTOMAX modes, the last channel pair of the output channels selection (channels 7-8, 15-16, 23-24 or 31-32) are reserved for future use and muted.

Note: The upMAX™ works with PCM audio. If non-PCM audio like Dolby E or Dolby Digital is fed to the module, it will be ignored and silenced to prevent interference with the other PCM audio channels.

6.5 N-channel ALC and upmix licensed by Linear Acoustic

Minimizing loudness differences between segments in a playout channel is an important issue in a world where multiple programs originating in different formats from different sources must be integrated seamlessly. The MOD-LA-ALC Automatic Loudness Control (ALC) module is the Grass Valley/Linear Acoustic solution to this need. It uses Linear Acoustic's AeroMAX™ *multiband* loudness control algorithm.

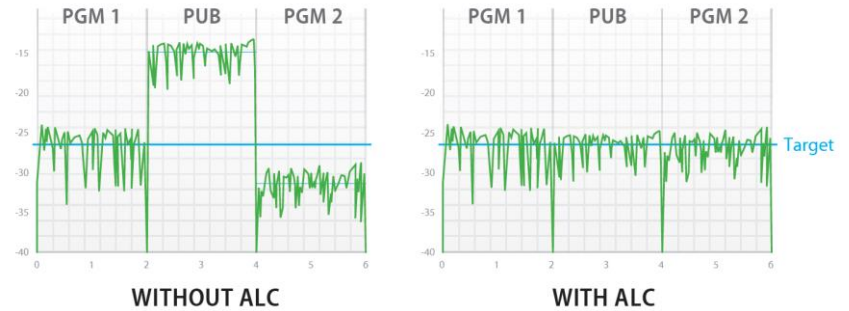

- Identified as MOD-LA-ALC-X-YYY on the module tab where X can be 2, 6 or 8 input channels and –YYY is the optional –DUP UpMAX™ module. The table shows the available MOD-LA-ALC models.

Model	Description	Output Channel Config.	
		PGM 1	PGM2
MOD-LA-ALC-2	2-Channel ALC licensed by Linear Acoustic	Up to 2.0	N/A
MOD-LA-ALC-2-DUP	2-Channel ALC and upmix licensed by Linear Acoustic	Up to 5.1	N/A
MOD-LA-ALC-6	6-Channel ALC licensed by Linear Acoustic	Up to 5.1	N/A
MOD-LA-ALC-6-DUP	6-Channel ALC and upmix licensed by Linear Acoustic	Up to 5.1	N/A
MOD-LA-ALC-8	8-Channel ALC licensed by Linear Acoustic	Up to 5.1	Up to 2.0
MOD-LA-ALC-8-DUP	8-Channel ALC and upmix licensed by Linear Acoustic	Up to 5.1	Up to 2.0

Depending on the model, different channel configurations are possible as listed in the table above.

The 6-channel ALC supports only a single program (either 5.1 or 2.0, but 4, 3 and 1 can be used), but the 8-channel ALC supports 2 independent programs.

- The first program (PGM 1) can only be configured as a single program 5.1 ALC or a 2.0 ALC. It is not possible to configure it as a 3x2, a 6x1 or any other channel combination with more than one program. If you are using only 3 channels (left, right and center), you can use the 5.1 configuration and leave the other 3 channels assigned to silence channels. You can even use the 5.1 ALC for a single mono channel as long as the other channels are assigned to silence channels.
- The second program (PGM 2) can only be configured as a 2.0 stereo program, but you can use it as a single mono program.

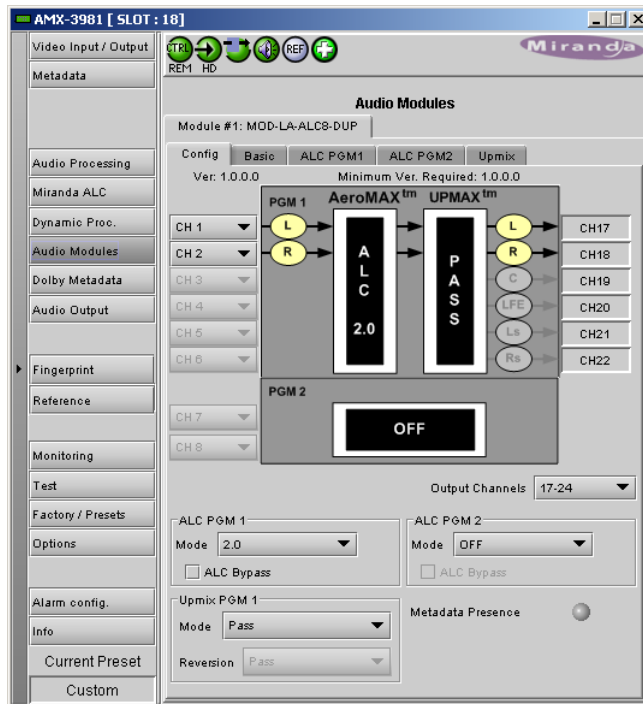
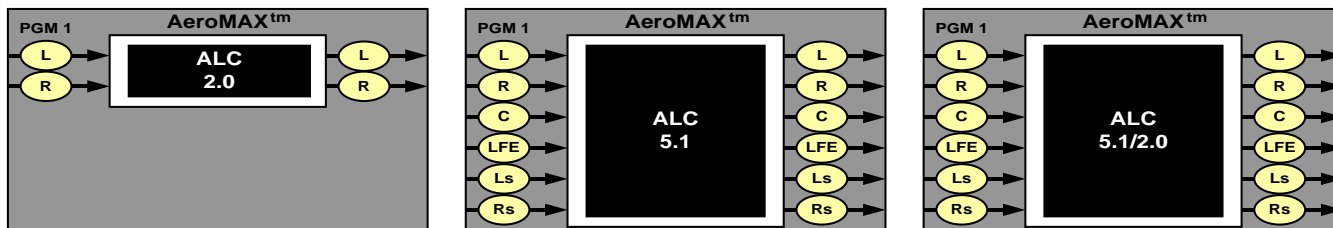
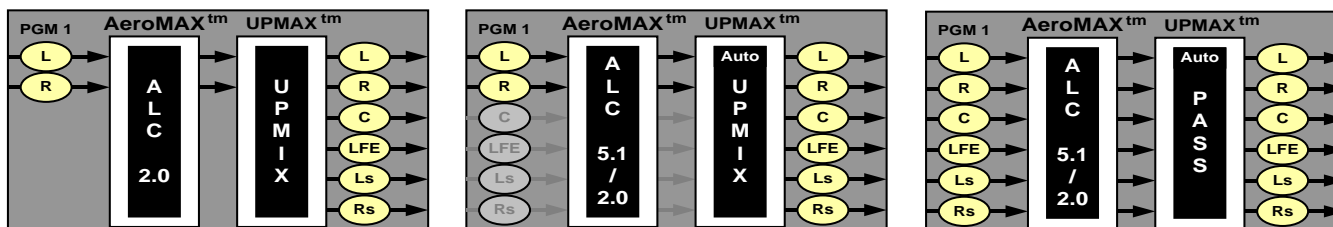

Figure 6.8 Audio Modules - LA-ALC-DUP

The figure below shows some of the most popular operating modes for the 5.1 ALC.



Modules with a -DUP feature the optional upMAX™ upmixer function licensed by Linear Acoustic. This processing creates a 5.1 channel surround field (Left, Right, Center, LFE, Left-Surround, Right-Surround) from a 2.0 channel stereo input (Left, Right). It is the same technology used on the MOD-LA-DUP-701 module. The figure below shows some typical configurations of the ALC equipped with the upmixer. The two pictures on the right show the upMAX™ in AutoMAX-II™ mode, where the configuration switches automatically between 2.0 and 5.1.



Note: The MOD-LA-ALC-X-YYY works with PCM audio. If non-PCM audio like Dolby E or Dolby Digital is fed to the module, it will be ignored and silenced to prevent interference with the other PCM audio channels.

Latency

The MOD-LA-ALC module processing latency is automatically compensated (to avoid lip-sync issues) when the additional video frame delay (**Timing** tab) is set to at least one (1) frame.

6.5.1 Config tab

The **ALC PGM x Mode** pull-downs specify the channel configuration for Program 1 & 2 (PGM 1 & 2). Depending on the ALC model, you may have different possible selections like 5.1, 2.0 or 5.1/2.0. This will indicate in which configuration you want to operate the module. If you want to do ALC on a stereo channel, select 2.0. For 5.1 input, select 5.1. The 5.1/2.0 configuration should be used when you have both 5.1 and 2.0 inputs, but you want to do an upmix on the 2.0 input, hence producing a constant 5.1 output. To upmix a mono channel, use the 2.0 configuration and assign both inputs to the desired mono channel.

If you have an ALC module with the –DUP upmix functionality, you can also configure the **Upmix PGM 1 Mode**.

If you set the ALC to work in 2.0 or 5.1/2.0 mode, the pull-down box offers four different processing solutions:

Pass Mode

Input channels are passed from the input to the output untouched.

Upmix Mode

The first 2 channels (L & R) are upmixed. The other input channels in PGM 1 are ignored.

AutoMAX-II™ Mode

In this mode, the module will automatically detect the presence of 5.1 or 2.0 channels at the input. When 2.0 is detected, the incoming stereo will be upmixed. When 5.1 is detected, the incoming 5.1 channels will automatically be passed through untouched.

Follow Metadata mode

This mode is another way to switch between 2.0 stereo and 5.1 and produce a constant 5.1 output. The **Coding Mode** parameter in the first program of the Dolby metadata will set the Operating Mode between Pass and Upmix modes.

Note: In *Follow Metadata* mode, the metadata generator will be automatically turned ON when the upMAX™ module is upmixing to provide a valid metadata stream for the upmixed audio content. The generator content must have been previously configured with valid 5.1 metadata parameters. When the upMAX™ module is set to *Pass* mode by the incoming metadata stream, the generator will be automatically turned OFF to let the incoming metadata stream pass through. Refer to *Generator Automated* mode in the Dolby metadata panel section for further details.

If the **Coding Mode** parameter is other than 3/2 (i.e. 5.1 channels) or 2/0 (i.e. stereo channels) or if the selected metadata path does not carry metadata, the Operating mode will follow the Reversion Mode pull-down.

The **Reversion Mode** pull-down sets the default Operating Mode to: Pass, Upmix, Last Valid (Last valid *Coding Mode*), AutoMAX.

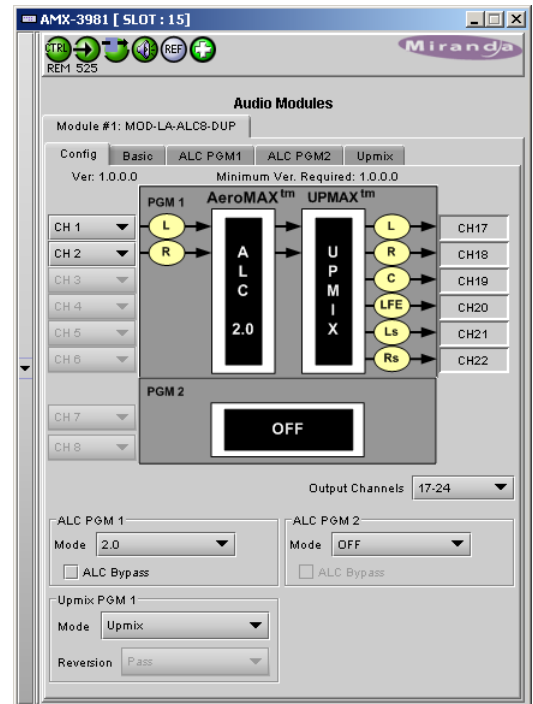

Figure 6.9 LA-ALC-DUP - Config tab

6.5.2 Basic tab

The “Basic” tab is the easiest way to configure the ALC module. You can use it to load an ALC Preset and specify the output level for each program.

Of course, all processing controls are accessible and users can custom design the presets that might be even more appropriate for a given situation. We strongly recommend starting with the ALC preset that is closest to the desired objective, then fine tuning it to reach the desired goal. This will minimize the troubles that will likely be encountered as many adjustments interact.

ALC Presets

- **TV 5B GEN - TeleVision 5-Band GENERAL.** This is the most commonly used preset. It provides a moderate degree of dynamic range processing, and is appropriate for all types of content. It is the factory default for all core preset choices.
- **TV 5B LIGHT - TeleVision 5-Band LIGHT.** This is very similar to TV 5B GEN, however the ratio of the multiband compression has been reduced closer to 2:1 for a more gentle action. Please be aware that lessening the processing lessens the ability of the unit to control loudness tightly to a given target.
- **TV 5B HVY - TeleVision 5-Band HEAVY.** Similar to TV 5B GEN, however the ratio of the multiband compression has been increased for a more dense and less dynamic sound.

• **TV 5B LOUD - TeleVision 5-Band LOUD.** Similar to TV 5B HVY, but louder and more punchy.

• **ITU LOUDness LMT** - Utilizes a specially tuned Input AGC plus Multiband Limiters and the Final Limiter to slowly adjust the average program loudness to a given value and the multiband and final limiters will act until the AGC catches up. This preset is appropriate for ingest or live applications but because the Multiband AGC is bypassed, it has less ability to manage spectral balance which is important for transmission.

• **PROTECTION LIMIT** - Bypasses all processing except for the final output limiter which is set only to prevent overload.

NOTE: All presets (except **PROTECTION LIMIT**) were tuned to produce audio that will have an average dialog loudness of **-24 dB/LKFS** as measured by a Dolby LM100.

For the other parameters in the Basic tab, refer to the Advanced Configuration section below.

6.5.3 Advanced Configuration – ALC PGM 1 & 2

We **STRONGLY** recommend starting with an ALC preset and modifying from there. Preset creation starting from scratch is an incredibly time consuming process requiring large amounts of time and huge amounts of content spanning all genres including music of every type, films of every type, television dramas and sitcoms of every type, and talking-head programs of every type. Linear Acoustic has already done much of the heavy lifting, and provides presets based on their own listening and feedback from customers over the past few years. Certain parameters such as crossover frequencies and channel coupling are not adjustable and are hard-coded to the most appropriate values. That being said, access to all adjustable parameters is provided. There are no factory adjustments hidden from users. Be careful with this power as most all settings interact with each other, sometimes in ways that might not be immediately audible.

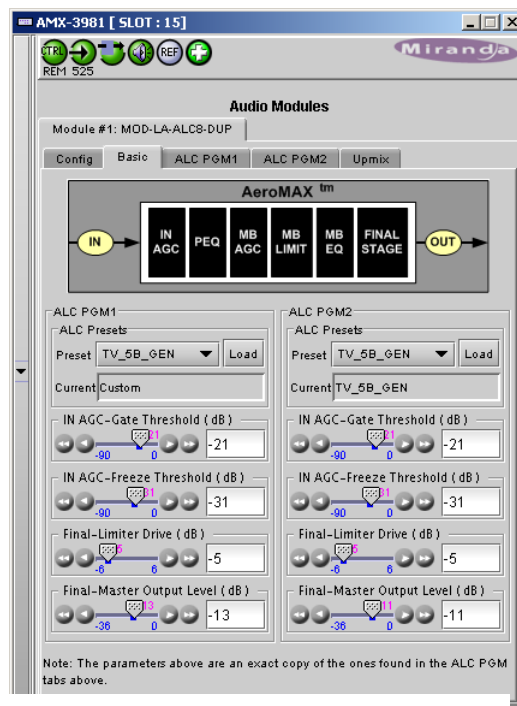

Figure 6.10 LA-ALC-DUP - Basic tab

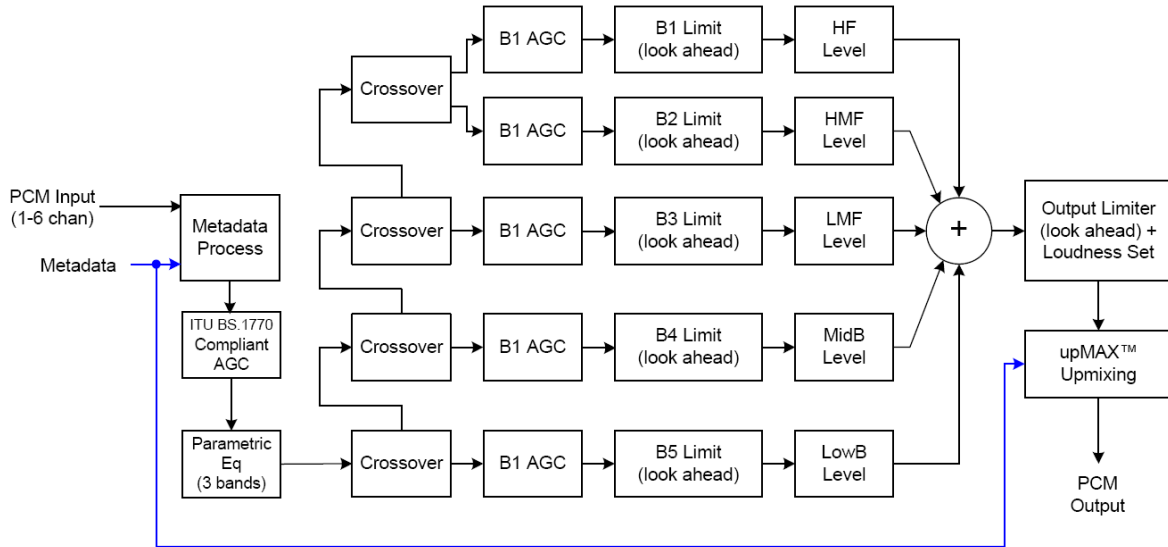

Figure 6.11 General signal flow of the AeroMAX™ processing core

The drawing above shows the general signal flow of the processing core to indicate what part of the chain is being adjusted by each parameter. Note that this signal flow is also captured in the “Adjust Processing” menu, with the top of the list being the input, and the bottom of the list being the output.

A word on the crossovers

The multiband crossovers in the AeroMAX™ consist of second order LinkwitzRiley style filters that are hard coded to specific frequencies. As the processing required for television applications is not as aggressive as other mediums, little advantage can be gained from changing these values, and the remainder of the processing relies on these characteristics remaining constant.

For reference, the crossover frequencies are:

- Band 1 (Low Bass): 20 Hz - 60 Hz
- Band 2 (Mid Bass): 30 Hz - 200 Hz
- Band 3 (Low Mid): 170 Hz - 1.15 kHz
- Band 4 (High Mid): 950 Hz - 6.1 kHz
- Band 5 (Brilliance): 5.2 kHz - 24 kHz

Input AGC

The input AGC is a very slow acting front-end gain control with a 36dB gain range whose only purpose is to make sure that the following processing stages are fed with the correct average audio levels. It is basically the automatic equivalent of an operator slowly riding a gain control on a console to keep the audio close to reference level. Wideband in nature, the AGC is not meant to perform rapid gain reduction or expansion as its actions will be more audible, as with all wideband gain processors. As a slow gain rider, its actions are nearly inaudible thanks to the multiband processing that follows it. The AGC has two stages of gating where the gain expansion is slowed or stopped to prevent background noise increasing.

Adjustable parameters are:

- Gate Threshold: 0dBFS to -90dBFS (default: -30dBFS). Gating sets the point at which the AGC release is made extremely slow to prevent increasing background noise and allow the AGC to return to unity gain.
- Freeze Threshold: 0dBFS to -90dBFS (default: -42dBFS). Freeze stops all gain change (i.e. when the audio drops to silence), and remains frozen at its current gain value until the threshold is exceeded.

NOTE: Adjust Gate and Freeze to match plant practices. Very quiet audio (such as a golf match) benefits from having processing frozen when input audio drops below a given level to prevent “boosting the cricket” sounds.

- Ratio: 1:1 to Inf:1 (default: 12.0:1)
- Range: 0dB - 36 dB (default: 24dB). Range sets how much gain expansion above unity is performed, and this amount is subtracted from the total AGC gain range of 36dB, so the default value allows for 24dB of expansion and 12dB of compression. This adjustment is reflected in real time by changing the AGC meter scale.
- Threshold: -18dBFS - 0dBFS (default: -16dBFS)
- Attack: 0 - 150, slowest - fastest (default: 21)
- Release: 0 - 150, slowest - fastest (default: 47)
- Progressive Release: 0 - 100, slowest - fastest (default: 50). Sets the speed at which the release time is increased faster at very low gain values. This feature approximates a logarithmic release to help recovery from dramatic gain reduction more quickly.

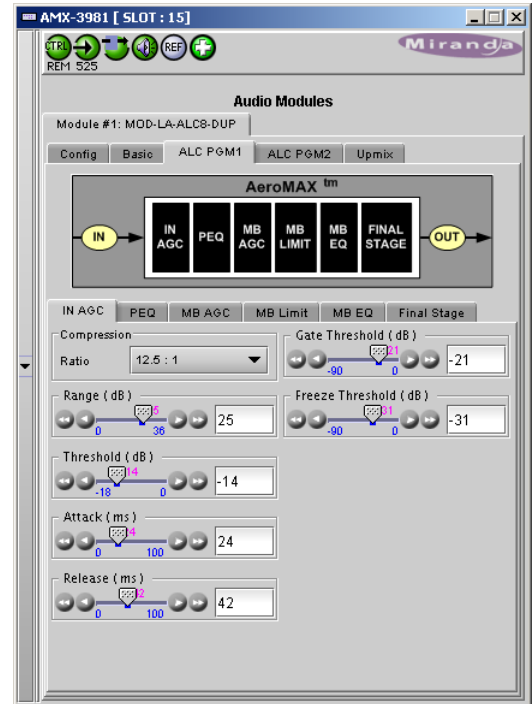

Figure 6.12 ALC - Input AGC

Parametric Equalization (PEQ)

Three bands of parametric equalization are provided for fine tuning if necessary. None of the factory-supplied presets use the parametric equalizers, but they are provided to create notch filters or other effects if necessary. Each filter has a gain control with a +/-12dB range, a center frequency control that varies from 20 Hz to 22.050 kHz, and a bandwidth or “Q” control that varies between 0 and 10. Normal default settings for all bands are Gain = 0dB, in other words bypassed.

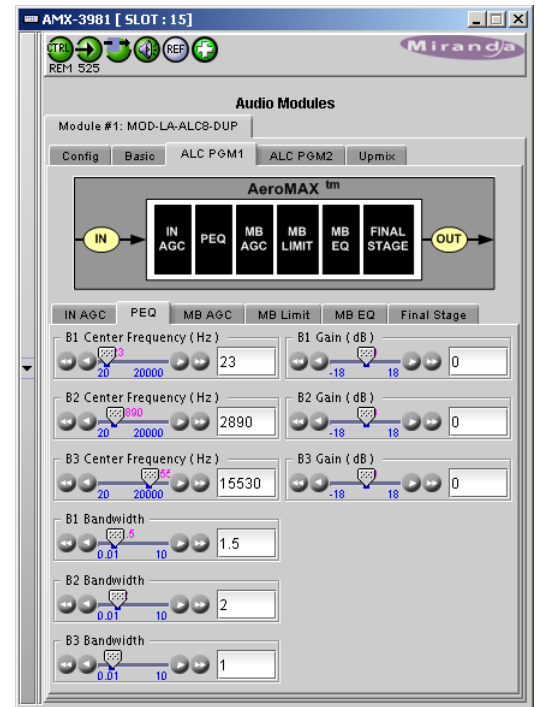

Figure 6.13 ALC - PEQ Parameters

Multiband AGC

This section is the heart of the dynamics processing engine. A multiband AGC (i.e. compressor) that allows for medium ratio (3:1 is default) adjustment of audio band. Adjustable parameters are divided amongst three tabs:

Main

- Compression Ratio: 1.0:1 - Inf:1 (default: 3.0:1)
- Range: 0dB - 36dB (default: 24dB). Range sets how much gain expansion above unity is able to be performed. This adjustment is reflected in real time by changing the AGC meter scale.
- Progressive Release: 0 - 100, slowest - fastest (default: 50). Sets the speed at which the release time is increased faster at very low gain values. This feature approximates a logarithmic release to help recovery from dramatic gain reduction more quickly.

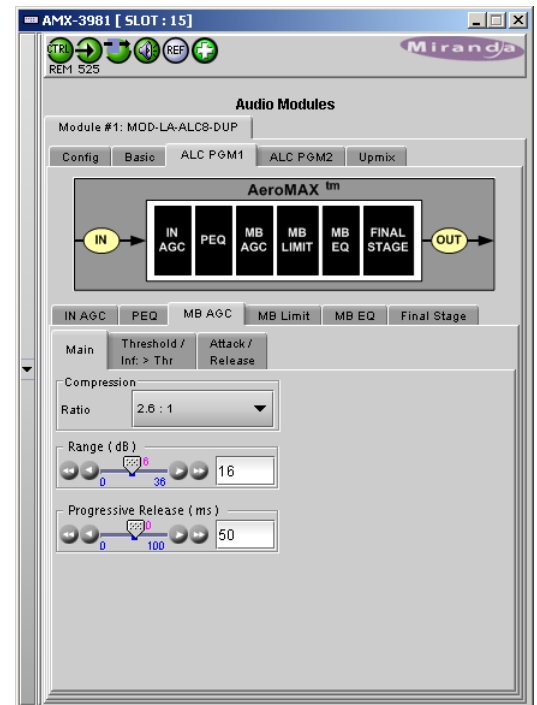

Figure 6.14 ALC - MB AGC - Main

Threshold /Inf > Thr

- B1 - B5 AGC Thresh(old): -12.00dB - +12.00dB (default: 0.00dB all). The reference point for the attack and release parameters to act on the audio signal present in that band.
- B1-B5 Inf:1 Above Thresh: Enabled / Disabled (default: B1: Enabled, B2: Enabled, B3: Disabled, B4: Disabled, B5: Disabled). AGC automatically increases the ratio to *Infinity:1* once a signal exceeds the threshold (set below), allowing for expansion below the threshold and limiting above the threshold. Useful for bass frequency control.

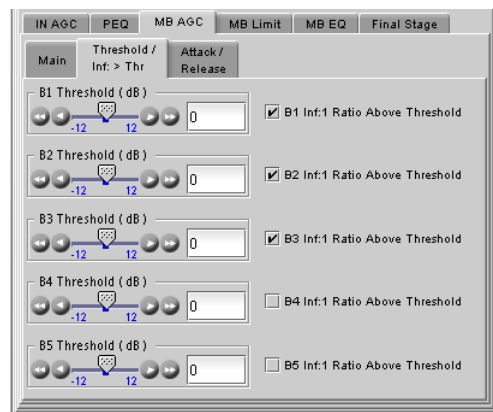

Figure 6.15 ALC - MB AGC - Threshold

Attack / Release

- B1 - B5 AGC Attack: 0 - 150, slowest - fastest (defaults: B1:46, B2:88, B3:88, B4:88, B5:92). How fast an input signal is acted upon once it crosses the set threshold
- B1 - B5 AGC Release: 0 - 150, slowest - fastest (defaults: B1:50, B2:60, B3:86, B4:88, B5:92). How fast an input signal recovers from a gain change once that signal falls below the set threshold.

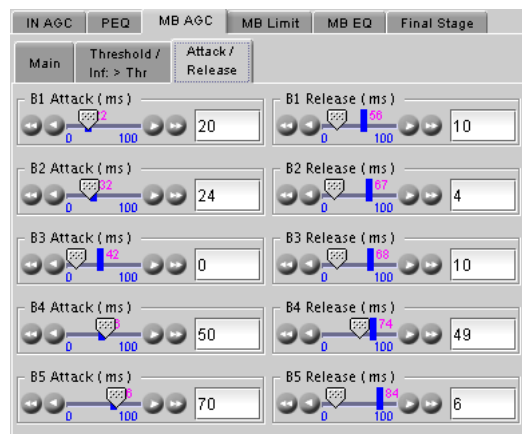

Figure 6.16 ALC - MB-AGC - Attack/Release

Multiband Limiters

Performs multiband limiting of the signals coming from the multiband compressor.

- B1 - B5 Lim(it) Thresh(old): +12.00dB - 0.00dB (default: B1:+4.25dB, B2:+4.25dB, B3:+6.50dB, B4:+9.00dB, B5:+9.00dB). The point above which limiting action takes place at an Infinity:1 ratio.
- B1 Soft Clip Thresh(old): +12.00dB - 0.00dB (default: +3.00dB)
- B2 Soft Clip Thresh(old): +12.00dB - 0.00dB (default: +6.00dB). The point above which band one (low bass) is very quickly limited, acting more like a clipper without the artifacts. This helps maintain a “tight” bass sound.

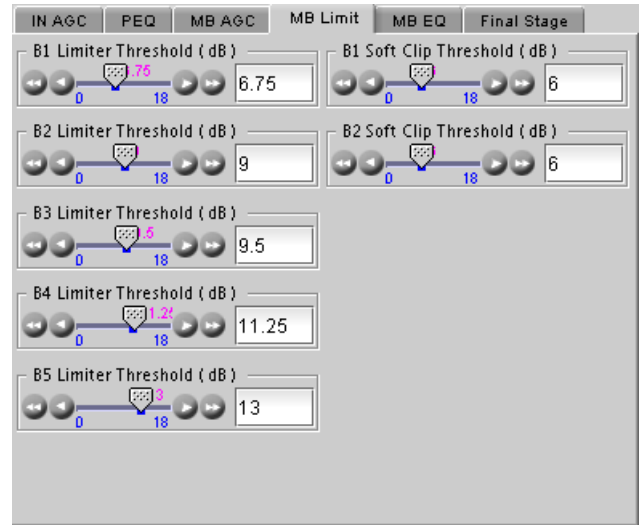

Figure 6.17 ALC module - MB Limiter

Multiband EQ

This is the section where each of the processing bands is summed and where overall frequency response can be tailored.

- B1 - B5 Out(put) Mix: -12dB - + 12dB (defaults: 0dB, all bands). Sets the mix level for each band summing all bands back together. These controls are prior to the final look-ahead limiter and increasing gain may cause more final limiting (possibly more than desired).

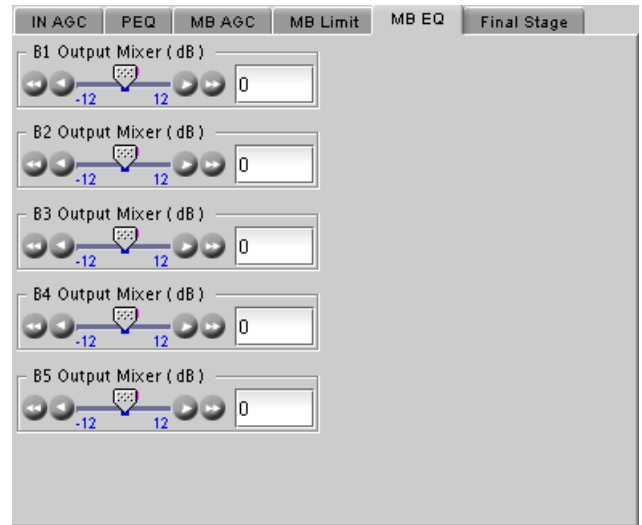

Figure 6.18 ALC module - MB Equalizer

Final Stage

This final section of the processor is where the final look-ahead peak limiter and bass soft clipper are adjusted. The look-ahead limiters are wideband, limited to 6dB of gain reduction, are extremely fast, and due to their look-ahead nature are virtually transparent even at full gain reduction. Their purpose is to control peaks that make it through the multiband section. Adjustable parameters are:

- Final Limiter Drive: -6dB - +6dB (default: -5dB). Sets the level at which the wideband sum of all bands is fed to the final limiter.
- Output Level: -36dB - 0dB (default: -13dB for PGM1, -11 dB for PGM2). Sets the output level for the current preset. Can be used to match the measured loudness of one preset to another. This is useful as more aggressive presets will measure differently from less aggressive versions.

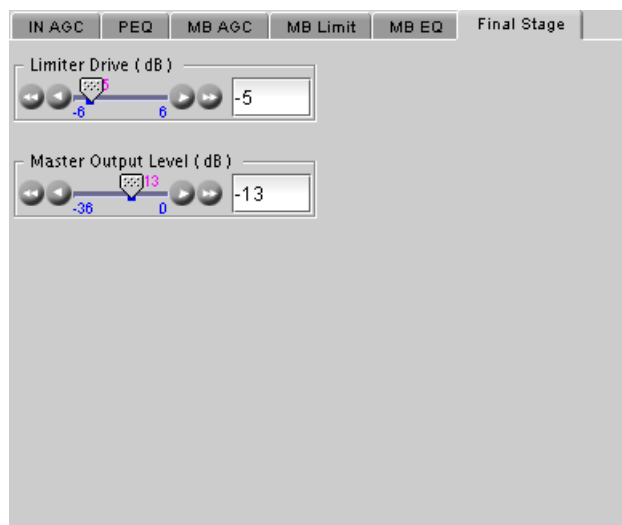

Figure 6.19 ALC Module - Final Stage

6.5.4 Upmix using Linear Acoustic UpMAX™

Surround Field Adjustments

The “surround field” can be adjusted with the Center channel Width control and the Surround channel Depth control.

AutoMAX-II Transition Speed

When the upmix operates in AutoMAX-II™ mode, the speed of the transitions from 2.0 to 5.1, and 5.1 to 2.0, can be configured to provide smooth and unobtrusive changeovers.

- Set the “Upmix-to-Pass” and “Pass-to-Upmix” transition speeds independently, over the range *Instant* to *Very Slow*

5.1/2.0 Detection Threshold

This parameter is used when the upmix operates in AutoMAX-II™ mode to detect silence on some of the 5.1 channels to determine if 5.1 or 2.0 is detected.

LFE Output Channel

The bass enhancement signal for the LFE channel is derived from the Left, Center and Right channels. The LFE checkbox and LFE Channel Level slider control the LFE output

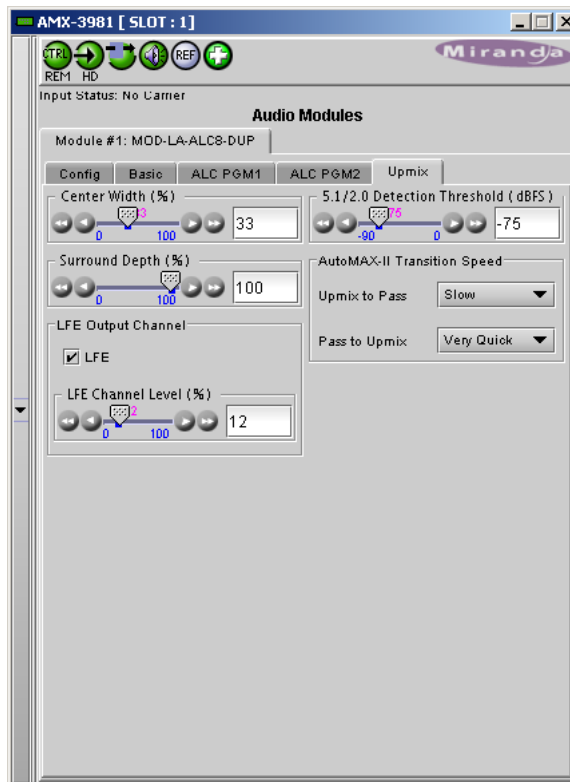

Figure 6.20 ALC module - Upmix using UpMAX

7 Specifications

VIDEO INPUT/OUTPUT

Signal (1):	SMPTE-259M-C (270 Mbps), SMPTE-292M (1.485, 1.485/1.001 Gbps), SMPTE-425 (2.970, 2.970/1.001 Gbps)
Supported formats:	SD: 480i59.94, 576i50 HD: SMPTE-274M: 1080i59.94, 1080i50 HD: SMPTE-296M: 720p59.94, 720p50 HD: SMPTE-425 level A (mapping 1), level B: 1080p59.94, 1080p50
Cable length:	300 m Belden 1694A at 270 Mbps, 150 m Belden 1694A at 1.485 Gbps, 120 m Belden 1694A at 2.970 Gbps
Return loss:	>15 dB up to 3 GHz
Jitter:	HD/SD: <0.2 UI 3G: <0.3 UI

AUDIO OUTPUT (8)

Sampling freq.:	48 kHz
Quantization:	24 bits
AES3	
Level:	2.75 Vp-p
Impedance:	110 ohms balanced
AES-3id	
Level:	1.0 Vp-p
Impedance:	75 ohms unbalanced
Return loss:	15 dB @ 6 MHz

REFERENCE INPUT

Signal (1):	Through the URS internal frame reference signal
-------------	---

OPTICAL

Signal:	Refer to SFP module specifications
---------	------------------------------------

LTC

Signal (1):	SMPTE 12M
Connector:	RJ-45 (-3SRP rear) BNC (-3DRP rear)
Impedance:	<10 kohm (bridging 600 ohm) unbalanced
Level:	0.3 to 5 Vp-p

GPIO (-3DRP rear)

Signal (3):	Contact closure to ground
Connector:	RJ-45
Direction:	Bidirectional (application specific)

GPIO (-3SRP rear)

Signal (2):	Contact closure to ground
Connector:	BNC
Direction:	Bidirectional (application specific)

RS-422

Signal (2):	RS-422
Input level:	300 mVp-p (min)
Output level:	3 Vp-p (min)
Rate:	115,200 bauds

VIDEO PROCESSING PERFORMANCE

Signal path:	10 bits
Processing delay (SD):	20 μ s (in minimum delay mode)
Processing delay (HD):	7.5 μ s (in minimum delay mode)
Processing delay (3G-Level A):	3.8 μ s (in minimum delay mode)
Processing delay (3G-Level B):	4 lines + 4 μ s (in minimum delay mode)
Additional delay:	Up to 15 frames upon user selection

AUDIO PROCESSING PERFORMANCE

Quantization:	24 bits
Sampling:	48 kHz, synchronous
Audio latency:	2 to 6 ms max in minimum delay depending on processing options
Audio delay:	Up to 2 s (1 ms steps)

ELECTRICAL

Power:	12.5 W
--------	--------

8 Contact Us

Grass Valley Technical Support

For technical assistance, contact our international support center, at 1-800-547-8949 (US and Canada) or +1 530 478 4148.

To obtain a local phone number for the support center nearest you, please consult the *Contact Us* section of Grass Valley's website (www.grassvalley.com).

An online form for e-mail contact is also available from the website.

Corporate Head Office

Grass Valley

3499 Douglas-B.-Floreani

St-Laurent, Quebec H4S 2C6

Canada

Telephone: +1 514 333 1772

Fax: +1 514 333 9828

www.grassvalley.com

ANNEX 1 – AMX-3981 Local User Interface

Menu level	LEV1	LEV2	LEV3	LEV4	VALUES	Conditions
Card Status	STATUS	GENERAL STATUS			REAR TYPE / OPTIC TYPE / AUDIO MODULE(s) / FAN ERROR / CRITICAL HEALTH (XXXX XXXX)	
		VIDEO STATUS			NO CARRIER / FORMAT / TRS ERROR / FIBER NO SIGNAL / REF FORMAT / REF MISMATCH / REF MISSING	
		AUDIO STATUS			GROUP PRESENCE 1 to 4 / AES PRESENCE	
		METADATA STATUS			LTC PRESENCE	
Configuration load	CONFIG	LOAD			[USER1, USER2, USER3, USER4, USER5]	
Configuration save		SAVE			[USER1, USER2, USER3, USER4, USER5]	
Reference Source	REFERENCE	SOURCE			[AUTO, URS, IN]	
URS rate		URS			[OFF, URS-29.97, URS-25]	
Input Configuration *	VIDEO IN/OUT	INPUT SELECT *			[BNC IN, FIBER IN1, FIBER IN2]	Requires -F rear module
Output Configuration *		FIBER OUTPUT	FIBER OUT 1 *		[OFF, ON]	Requires -F rear module
			FIBER OUT 2 *		[OFF, ON]	Requires -F rear module
Additional Frame Delay		TIMING	FRAME *		[0, 1, ..., 15]	Min Delay OFF
Input Timing to REF			IN TIME TO REF		[display timing]	
Deglitcher mode		DEGLITCHER			[OFF, ON]	
AFD mode	AFD	MODE			[PASS, BLANK, AUTO, INSERT]	
Default AFD flag		DEFAULT			[4:3_0, 4:3_1, ..., 16:9_15, KEEP LAST]	auto AFD mode
Forced AFD flag		INSERT			[4:3_0, 4:3_1, ..., 16:9_15]	insert AFD mode
		SOURCE			[AFD, VLI]	525 SD in
					[AFD, VLI, WSS]	625 SD in
		INSERTION			[AFD, VLI]	525 SD in
					[AFD, VLI, WSS]	625 SD in
Level and Delay lock	AUDIO	PROC	CHANNEL 1	LOCK	[OFF, CH01, ..., CH32]	
Audio Level				LEVEL	[-96, ..., 0, ..., 12]	step = .5dB
Channel Phase Inversion				PHASE INVERT	[OFF, ON]	
Channel Mute				MUTE	[OFF, ON]	
Lip-Sync Correction				DELAY MSEC	[0, 2000]	unit=ms
Fine Audio Alignment				DELAY SAMPLES	[-100, 0, 100]	unit=sample
Dynamic Audio Proc				DYN GROUP MODE	[MONO, STEREO, GROUP 1, GROUP 2]	
				COMPRESSOR	ATTACK TIME	[1 ms, 10 ms, 40 ms, 160 ms]
					RELEASE TIME	[48 dB/s, 24 dB/s, 12 dB/s, 6 dB/s]
					THRESHOLD	[0 dBFS, -1 dBFS, ..., -60 dBFS]
					RATIO	[1/1, 1/1.25, 1/1.5, 1/1.75, 1/2, 1/3, 1/4, 1/8, 1/16]
				EXPANDER	THRESHOLD	[-40 dBFS, -41 dBFS, ..., -80 dBFS]
					RATIO	[1/1, 1.125/1, 1.25/1, 1.375/1, 1.5/1, 1.625/1, 1.875/1, 2/1]
				DYNAMIC GAIN	[0 dB, 1 dB, ..., 24 dB]	
			-- --	----		
			CHANNEL 32	----		
Audio Sample Rate Converter		SRC	AES IN 1		[OFF, AUTO]	
			AES IN 2		[OFF, AUTO]	
			AES IN 3		[OFF, AUTO]	
			AES IN 4		[OFF, AUTO]	
			AES IN 5		[OFF, AUTO]	
			AES IN 6		[OFF, AUTO]	
			AES IN 7		[OFF, AUTO]	
			AES IN 8		[OFF, AUTO]	
Embed. Output Shuffler/Mixer		VIDEO OUTPUT	CHANNEL 1	MODE	[OFF, A, A+B, MIX]	
				CHNA	[CH01, ..., CH32]	
				MIXA	[-96, ..., 12] step = .5dB	
				CHNB	[CH01, ..., CH32]	
				MIXB	[-96, ..., 12] step = .5dB	
			CHANNEL 2	MODE	[OFF, A, A+B, MIX, MIX 4CH]	
				CHNA	[CH01, CH02, ..., CH32]	
				MIXA	[-96, ..., 12] step = .5dB	
				CHNB	[CH01, ..., CH32]	
				MIXB	[-96, ..., 12] step = .5dB	
				SWAP	[OFF, ON]	
			-- --	----		
			CHANNEL 16	----		
Audio/Video Test	TEST PATTERN				[OFF, COLOR BAR, LIPSYNC]	
Firmware Version	VERSION				[AMX-3981 : XXX, CPU BUILD: XXX, FPGA BUILD: XXX]	
Dynamic Proc Option	OPTIONS	DYN PROC	ON/OFF		Key:XX.XX.XX.XX	
ALC Options		ALC	ON/OFF		Key:XX.XX.XX.XX	
Factory Card Parameters	FACTORY RESET	CARD PARAMETERS			[NO, YES]	
Factory Led Alarms		CARD LED ALAR			[NO, YES]	

Note: Some menu items may not be present depending on input format, or card configuration.

ANNEX 2 – Installing the Optical Interface

Installing and removing the Fiber I/O interface cartridge requires special care. This annex describes the process.

Some rear panels used with the AMX-3981 incorporate a fiber optic interface. The interface consists of two parts:

- A socket on the rear panel into which an SFP interface module is plugged
- An SFP (Small Form-factor Pluggable) module into which the optical fibers are plugged, and which incorporates the optical/electrical interface

Cautions and Warnings



SFP Transmitter modules contain a class 1 laser, which emits invisible radiation whenever the module is powered up. Because the SFP is hot-swappable, the module may be powered up as soon as it is installed.

DO NOT LOOK INTO AN OPERATING SFP MODULE'S CONNECTORS, AS EYE DAMAGE MAY RESULT.



The SFP module is sensitive to electrostatic discharge (ESD). It is recommended that you use an ESD-preventive wrist strap grounded to the Densité chassis while handling the SFP module.



SFP modules are subject to wear, and their useful lifetime is reduced each time they are inserted or removed. Do not remove them more often than is absolutely necessary.



Never remove or install an SFP module with the fiber optic cables connected. Damage to the cables could result.



The presence of dust and debris can seriously degrade the performance of an optical interface. It is recommended that you insert a dust plug into the SFP module whenever a fiber optic cable is not connected.

Installing an SFP module

1. Make sure that the bale clasp lever is in the closed position

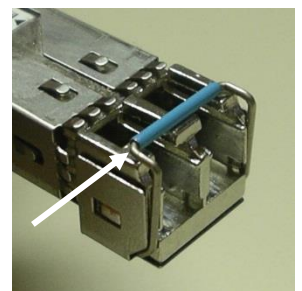

2. Position the SFP module so that the recessed slot is lined up with the tab side of the socket.

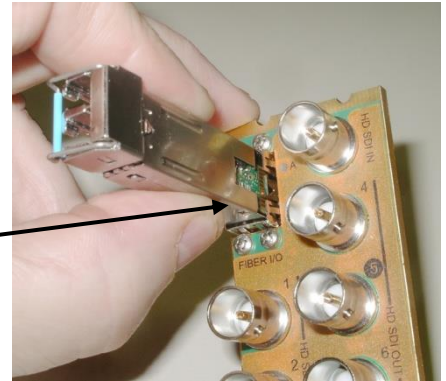
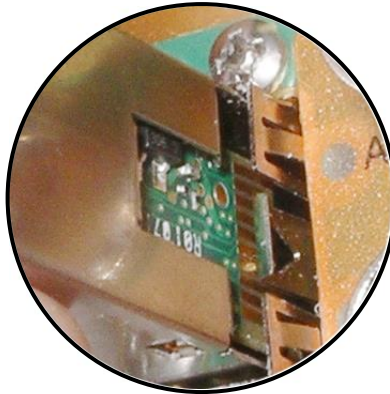

3. Slide the module straight into the socket, and push gently until it clicks into position.

Connecting the fiber optic cables

1. Remove the dust plug from the SFP module if present
2. Verify that the exposed end of the optical fiber in the LC connector is clean
 - Carefully remove any debris if necessary.
3. Plug the LC-terminated fiber optic cable into the SFP module

Removing the fiber optic cables

1. Grasp the LC fiber optic connector that is plugged into the SFP module, and pull it straight out to disengage the optical fiber from the SFP.
 - Never pull the fiber optic cable itself, as catastrophic damage may occur.
2. Insert a dust plug into the SFP module.

Removing the SFP module

1. Move the bale clasp lever to the open position.

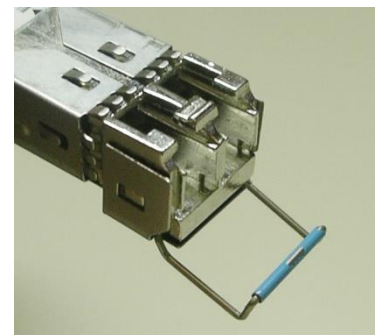
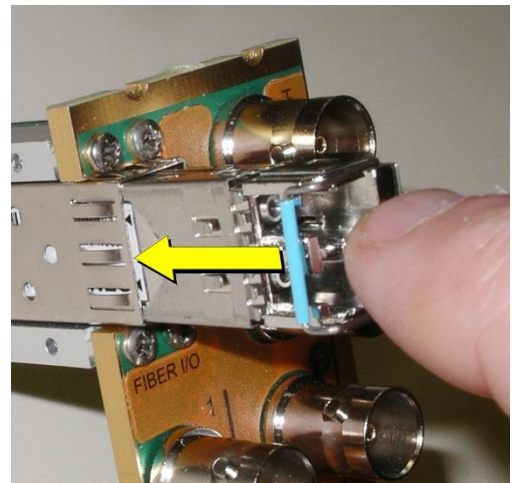

2. Grasp the SFP module between your thumb and forefinger, and pull it straight out of the slot.
 - Do NOT pull on the bale clasp lever to remove the module, as it is easily damaged
 - You may find that you need to wiggle the module, or perhaps push it into the slot a bit, before it will release and slide out.

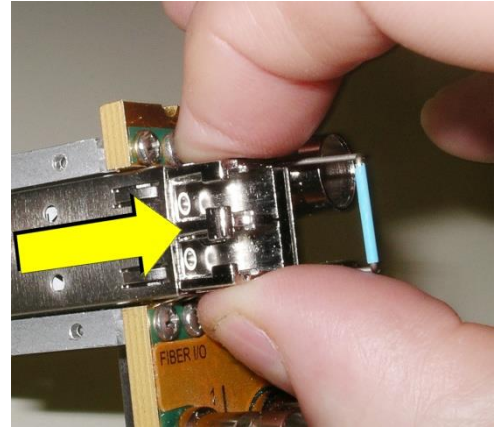

3. Insert a dust plug into the SFP module.

ANNEX 3 – Installing the Audio Modules

To install an audio module:

1. Remove the card from the frame
2. The socket for the audio module is located along the top edge of the card.

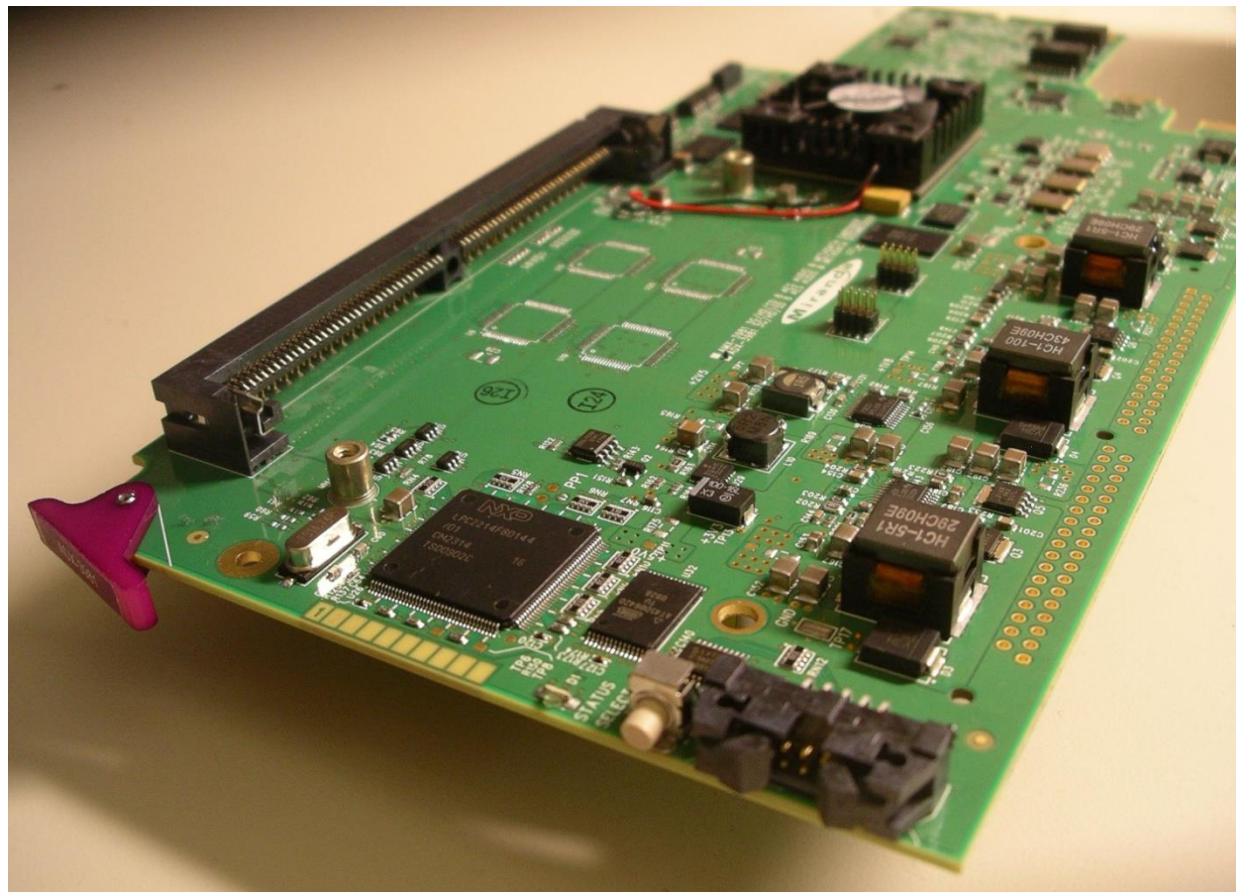

3. Remove the audio module from its packaging.

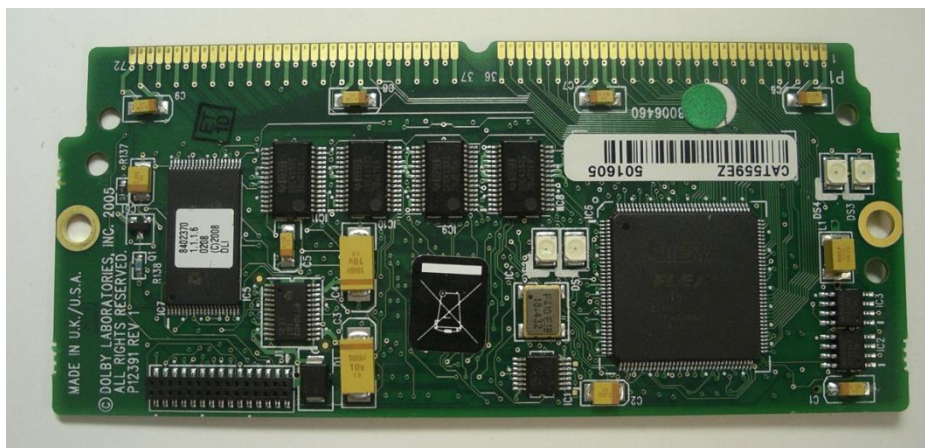

4. Hold the audio module tilted at about a 30 degree angle and insert its connector into the socket, as shown in the photo below.

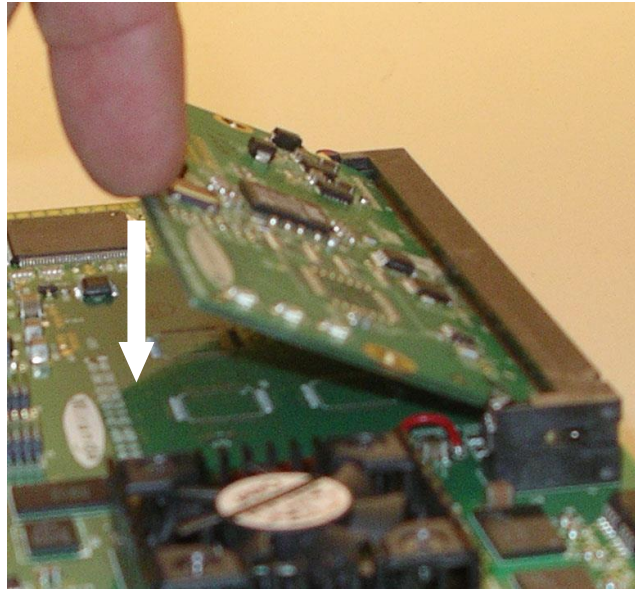
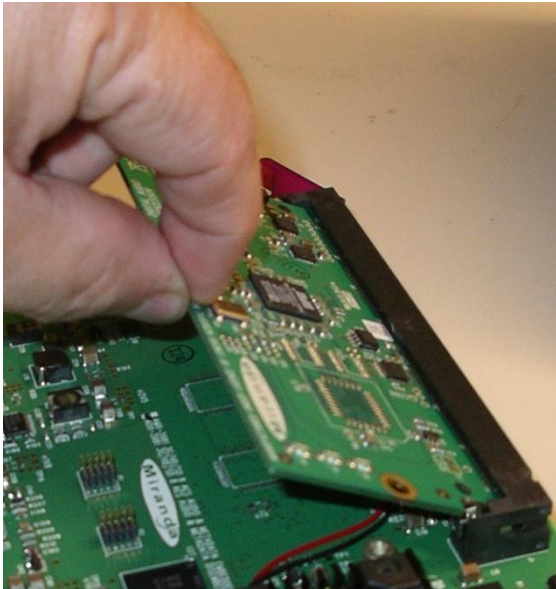

5. Push down on the module until it is parallel to the surface of the card. It will click into place
6. Installed the 2 provided screws in the holes on each side of the module, securing the module to the posts on the card.

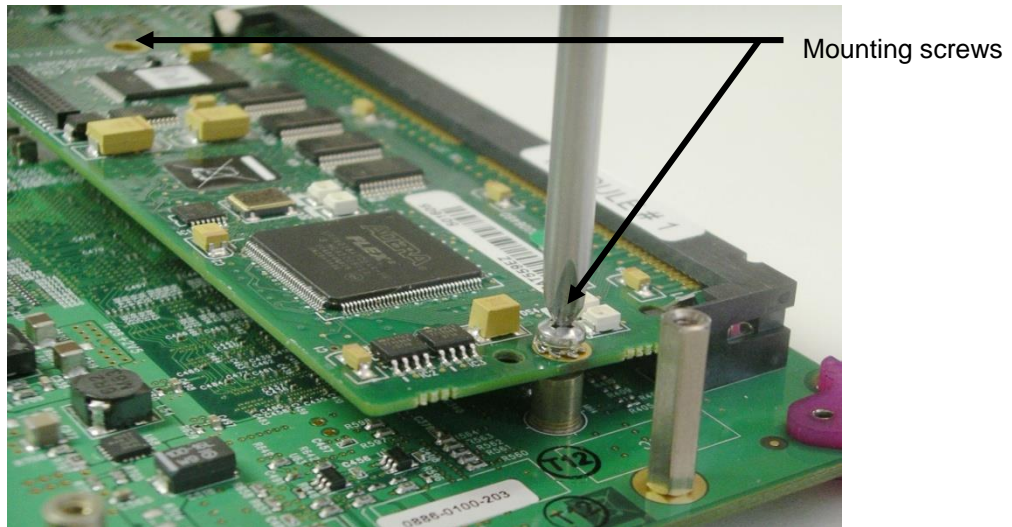

7. Insert the card in the frame.
8. Make sure that the module is correctly detected in the detected "Audio modules" tab of the card's panel or in the "General Status" menu of the local user interface (card edge menu). Controls and parameters for the module installed are available only in the "Audio modules" tab of the card's panel.

To remove an audio module:

1. Remove the card from the frame
2. Remove the two screws that secure the module to the card



3. Push outward on the two metal clips that hold the module in the horizontal position, one located at each corner of the socket. The module will release and tilt upward

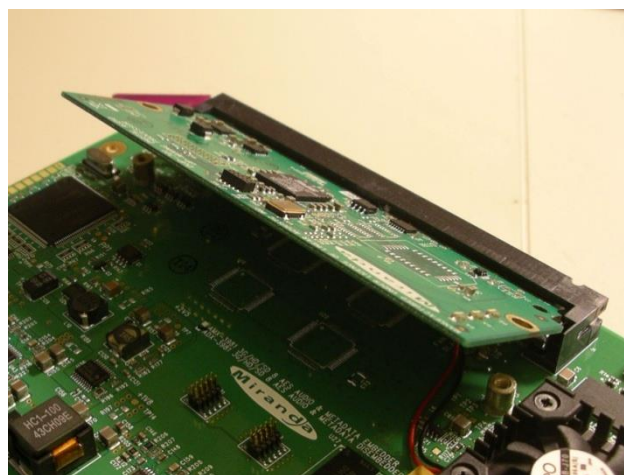
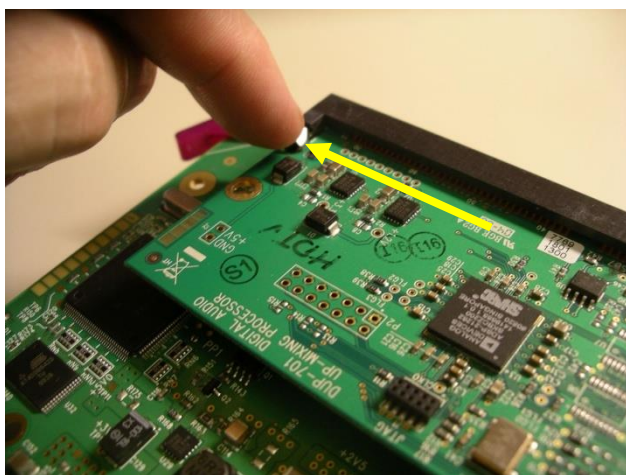

4. Pull the module out of the socket

ANNEX 4 – Dolby Digital Main Channel Output Functions

Coding Mode	Listening Mode	Main Channel Output Function
3/2	Full	All 3/2 channels
	3 Stereo	3 Stereo downmix of 3/2 channels
	Phantom	Phantom downmix of 3/2 channels
	Stereo	Lo/Ro downmix
	Mono	Lo+Ro
2/2	Full	All 2/2 channels
	3 Stereo	Default to Stereo mode
	Phantom	Default to Full mode
	Stereo	Lo/Ro downmix
	Mono	Lo+Ro
3/1	Full	All 3/1 channels
	3 Stereo	S mixed into L and R with smix coefficient
	Phantom	C mixed into L and R with cmix coefficient
	Stereo	Lo/Ro downmix
	Mono	Lo+Ro
2/1	Full	All 2/1 channels
	3 Stereo	S mixed into L and R with smix coefficient
	Phantom	Default to Full mode
	Stereo	Lo/Ro downmix
	Mono	Lo+Ro
3/0	Full	Default to 3 Stereo mode
	3 Stereo	All 3/0 channels
	Phantom	C mixed into L and R with cmix coefficient
	Stereo	Lo/Ro downmix
	Mono	Lo+Ro
2/0	Full	Default to Stereo mode
	3 Stereo	Default to Stereo mode
	Phantom	Default to Stereo mode
	Stereo	2/0 channels
	Mono	L+R
1/0	Full	Default to Mono mode
	3 Stereo	Default to Mono mode
	Phantom	Default to Mono mode
	Stereo	Default to Mono mode
	Mono	Mono center channel output
1+1	Full	Default to Stereo mode
	3 Stereo	Default to Stereo mode
	Phantom	Default to Stereo mode
	Stereo	L and R output
	Mono	L+R

ANNEX 5 – AFD Flags

The two charts below list all available Active Format Descriptor (AFD) flags supported by the AMX-3981.

In the images shown in the chart:

BLACK  Indicates that this portion of the transmitted image will be black

GREY  indicates Protected Area, consisting of picture content which may be cropped for optimum display on screens with a different aspect ratio.

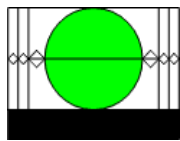
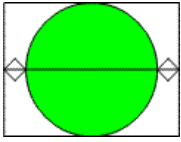
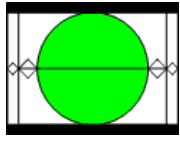
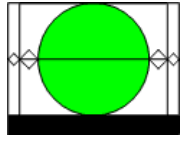
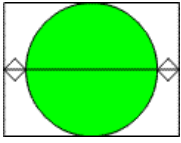
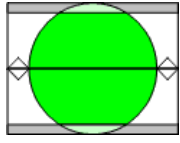
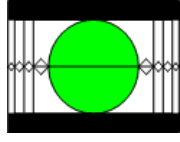
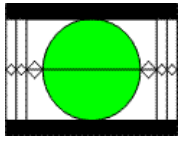
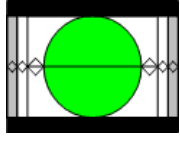
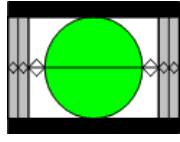
4:3 AFD flags		
<p>16:9 Letterbox (top) image in a 4:3 frame</p>  <p>(4:3_2)</p>	<p>4:3 Full frame image in a 4:3 frame</p>  <p>(4:3_8)</p>	<p>14:9 Letterbox image in a 4:3 frame</p>  <p>(4:3_11)</p>
<p>14:9 Letterbox (top) image in a 4:3 frame</p>  <p>(4:3_3)</p>	<p>4:3 Full frame image in a 4:3 frame (use preferred 4:3_8 code instead)</p>  <p>(4:3_9)</p>	<p>4:3 Image shoot and protect 14:9 in a 4:3 frame</p>  <p>(4:3_13)</p>
<p>> 16:9 Letterbox (center) image in a 4:3 frame</p>  <p>(4:3_4)</p>	<p>16:9 Letterbox image in 4:3 frame</p>  <p>(4:3_10)</p>	<p>16:9 Letterbox image shoot and protect 14:9 in a 4:3 frame</p>  <p>(4:3_14)</p>
<p>16:9 Letterbox image shoot and protect 16:9 in a 4:3 frame</p>  <p>(4:3_15)</p>		

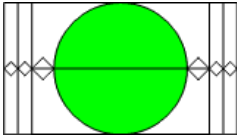
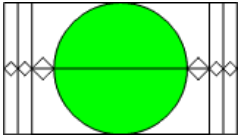
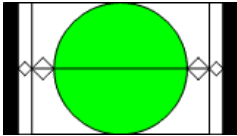
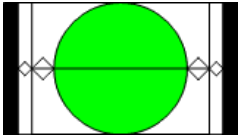
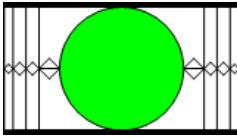
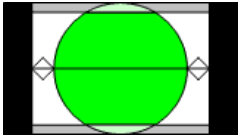
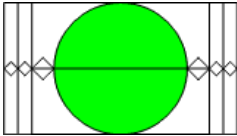
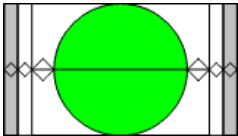
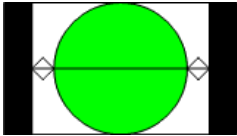
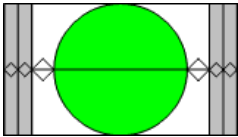
16:9 AFD flags	
<p>16:9 Full frame image in a 16:9 frame (use preferred 16:9_8 flag instead)</p>  <p>(16:9_2)</p>	<p>16:9 Protected Full frame image in a 16:9 frame</p>  <p>(16:9_10)</p>
<p>14:9 Pillar-box image in a 16:9 frame (use preferred 16:9_11 flag instead)</p>  <p>(16:9_3)</p>	<p>14:9 Pillar-box image in a 16:9 frame</p>  <p>(16:9_11)</p>
<p>> 16:9 Letterbox (center) image in a 16:9 frame</p>  <p>(16:9_4)</p>	<p>4:3 Pillar-box image Shoot and protect 14:9 in a 16:9 frame</p>  <p>(16:9_13)</p>
<p>16:9 Full frame image in a 16:9 frame</p>  <p>(16:9_8)</p>	<p>16:9 Image shoot and protect 14:9 in a 16:9 frame</p>  <p>(16:9_14)</p>
<p>4:3 Pillar-box image in 16:9 frame</p>  <p>(16:9_9)</p>	<p>16:9 Image shoot and protect 4:3 in a 16:9 frame</p>  <p>(16:9_15)</p>

ANNEX 6 – Loudness Logging and the Audio Loudness Analyzer

Activating and Managing Loudness Logging

Use iControl or iControl Solo to activate the loudness logging feature of the AMX-3981, and specify the location where the log files will be saved for future analysis.

1. In the Logical View of your iControl Application (iControl Solo or iControl Navigator) open the Managers folder, and double-click on Loudness Logger

- Note that in Navigator, there may be more than one logger available; be sure to select the one associated with the appserver whose DensitéManager was used to install the AMX-3981.

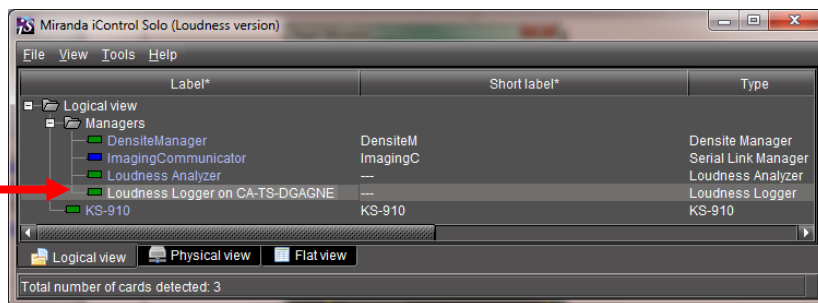

2. A list of loudness monitoring resources will appear, including your AMX-3981.

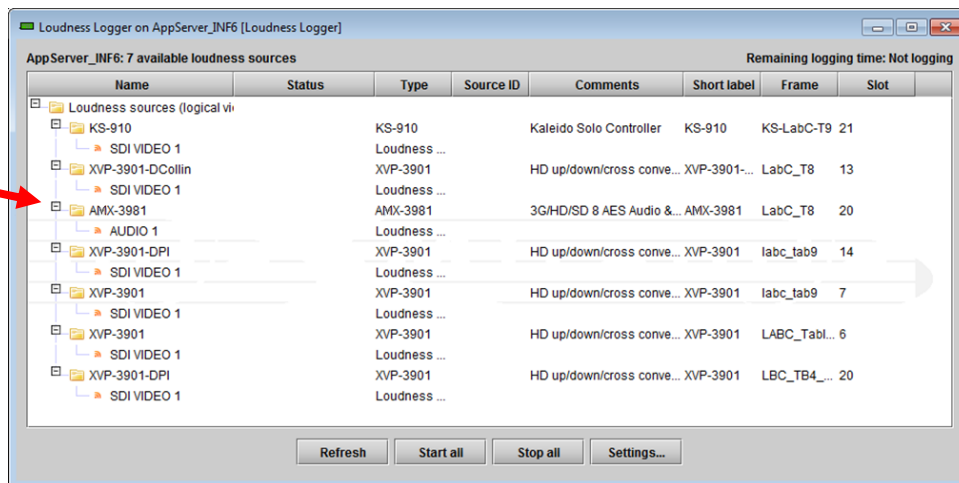

3. Click “Settings” to specify the path to the location where loudness data files will be saved.

4. Browse to the desired location and click the “Apply” button.

Note that the Settings apply to all loudness sources reported in the window, so be careful not to change them if other sources are active.

5. To start logging on an individual AMX-3981, right-click on its icon and select “Start”
6. To start logging on all the loudness sources in the display, click the “Start all” button.
7. Look under “Status” and verify that logging is in progress, as indicated by the green check mark.
8. To stop logging, right-click on the individual AMX-3981 and select “Stop”, or click “Stop all” to stop logging on all devices in the list.

Starting the Audio Loudness Analyzer from iControl

The Audio Loudness Analyzer processes the log files saved from the AMX-3981, as described above.

1. From your iControl Application (iControl Solo or iControl Navigator), double-click *Loudness Analyzer*.

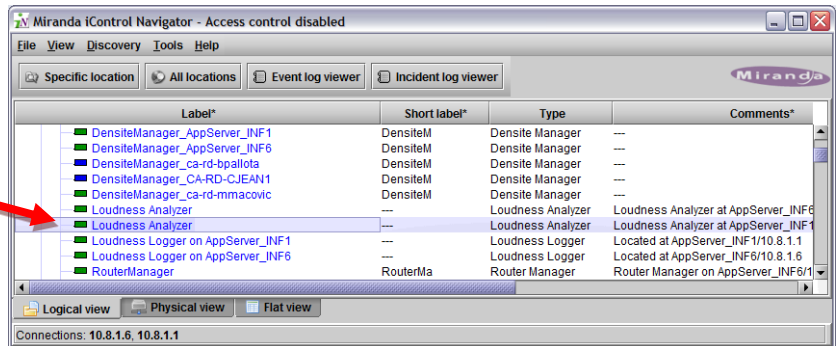

The complete user manual for the Audio Loudness Analyzer is available from its Help menu.

1. Pull down Help and select Open Help to see the manual
2. Consult the manual as necessary to perform the loudness analysis.

