



grass valley

A **BELDEN** BRAND

IPG-3901

High Density SDI/IP Gateway

Guide to Installation and Operation

M3036-9900-110

2016-02-23

www.grassvalley.com

Document History

Document Number	Date of Publication	Notes
3036-99M00-100	2015-10-06	Initial Release
3036-99M00-110	2016-02-23	Support for external reference added

Copyright and Trademark Notice

Copyright © 2015-2016, Grass Valley USA, LLC. All rights reserved.

Belden, Belden Sending All The Right Signals, and the Belden logo are trademarks or registered trademarks of Belden Inc. or its affiliated companies in the United States and other jurisdictions. Grass Valley, Miranda, IPG-3901, iControl, and Densité are trademarks or registered trademarks of Grass Valley USA, LLC. Belden Inc., Grass Valley USA, LLC, and other parties may also have trademark rights in other terms used herein.

Terms and Conditions

Please read the following terms and conditions carefully. By using IPG-3901 documentation, you agree to the following terms and conditions.

Grass Valley hereby grants permission and license to owners of IPG-3901 to use their product manuals for their own internal business use. Manuals for Grass Valley products may not be reproduced or transmitted in any form or by any means, electronic or mechanical, including photocopying and recording, for any purpose unless specifically authorized in writing by Grass Valley.

A Grass Valley manual may have been revised to reflect changes made to the product during its manufacturing life. Thus, different versions of a manual may exist for any given product. Care should be taken to ensure that one obtains the proper manual version for a specific product serial number.

Information in this document is subject to change without notice and does not represent a commitment on the part of Grass Valley.

Warranty information is available in the Support section of the Grass Valley Web site (www.grassvalley.com).

Electrostatic Discharge (ESD) Protection



Electrostatic discharge occurs when electronic components are improperly handled and can result in intermittent failure or complete damage adversely affecting an electrical circuit. When you remove and replace any card from a frame always follow ESD-prevention procedures:

- Ensure that the frame is electrically connected to earth ground through the power cord or any other means if available.
- Wear an ESD wrist strap ensuring that it makes good skin contact. Connect the grounding clip to an *unpainted surface* of the chassis frame to safely ground unwanted ESD voltages. If no wrist strap is available, ground yourself by touching the *unpainted* metal part of the chassis.
- For safety, periodically check the resistance value of the antistatic strap, which should be between 1 and 10 megohms.
- When temporarily storing a card make sure it is placed in an ESD bag.
- Cards in an earth grounded metal frame or casing do not require any special ESD protection.

Recycling

Visit www.grassvalley.com for recycling information.

Certification and Compliance

Safety of Laser Modules



This equipment incorporates modules containing Class 1 lasers. These modules are certified by the manufacturer to comply with:

- IEC/EN 60825-1 Safety of laser products
- IEC 60950-1 Safety of information technology equipment

Restriction on Hazardous Substances (RoHS)

IPG-3901	有毒有害物质或元素 (Toxic or Hazardous Substances and Elements)					
	铅 (Pb)	汞(Hg)	镉(Cd)	六价铬 (Cr6)	多溴联苯 (PBB)	多溴二苯 (PBDE)
部件名称 Part name						
电缆及电缆组件 Cables and Cable Assemblies	O	O	O	O	O	O
电路模块 Circuit Modules	X	O	O	O	O	O
组装风扇 Fan Assemblies	X	O	O	O	O	O
IPG-3901-3DRP, IPG-3901-3TRP	有毒有害物质或元素 (Toxic or Hazardous Substances and Elements)					
	铅 (Pb)	汞(Hg)	镉(Cd)	六价铬 (Cr6)	多溴联苯 (PBB)	多溴二苯 (PBDE)
部件名称 Part name						
电路模块 Circuit Modules	X	O	O	O	O	O

O: 表示该有毒有害物质在该部件所有均质材料中的含量均在SJ/T 11363-2006规定的限量要求以下。

O: Indicates that this toxic or hazardous substance contained in all of the homogeneous materials for this part is below the limit requirement in SJ/T11363-2006.

X: 表示该有毒有害物质至少在该部件的某一均质材料中的含量超出SJ/T 11363-2006规定的限量要求。

X: Indicates that this toxic or hazardous substance contained in at least one of the homogeneous materials for this part is above the limit requirement in SJ/T11363-2006.

技术条款解释：

此声明所依据之数据由Grass Valley环境管理部门向我们的部件供应商获取。Grass Valley 公司相信此信息的正确性，但由于数据来源于公司外部，我们无法保证它的完整和准确。所有这些特性可能在未获通知的情况下更改。

Technical explanations:

This statement is based on the information provided by our suppliers of components and collected through Grass Valley's environmental management system. Grass Valley believes this environmental information to be correct but cannot guarantee its completeness or accuracy as it is based on data received from sources outside our company. All specifications are subject to change without notice.

Electromagnetic Compatibility



This equipment has been tested for verification of compliance with FCC Part 15, Subpart B requirements for Class A digital devices.

NOTE: This equipment has been tested and found to comply with the limits for a Class A digital device, pursuant to part 15 of the FCC Rules. These limits are designed to provide reasonable protection against harmful interference when the equipment is operated in a commercial environment. This equipment generates, uses, and can radiate radio frequency energy and, if not installed and used in accordance with the instruction manual, may cause harmful interference to radio communications. Operation of this equipment in a residential area is likely to cause harmful interference in which case the user will be required to correct the interference at his own expense.



This equipment has been tested and found to comply with the requirements of the EMC directive 2004/108/CE:

- EN 55022 Class A radiated and conducted emissions
- EN 61000-3-2 Harmonic current emission limits
- EN 61000-3-3 Voltage fluctuations and flicker limitations
- EN 61000-4-2 Electrostatic discharge immunity
- EN 61000-4-3 Radiated electromagnetic field immunity – RF
- EN 61000-4-4 EFT immunity
- EN 61000-4-5 Surge immunity
- EN 61000-4-6 Conducted immunity
- EN 61000-4-8 EMP immunity
- EN 61000-4-11 Voltage-dips, short-interruption and voltage variation immunity

Table of Contents

1	IPG-3901 High Density SDI/IP Gateway for Densité 3 Platform.....	1
1.1	Introduction	1
1.2	Features	1
1.3	Functional Block Diagram	2
1.4	Front Card-edge Interface.....	2
2	Installation.....	3
2.1	Installation of Rear Connector Panels	3
2.2	IPG-3901 Card Installation.....	3
2.3	Rear Panels and Connectors.....	4
2.3.1	Images of Rear Panel Connectors.....	4
2.3.2	Summary of rear panel connections	4
2.3.3	Details of rear panel connections	5
3	User Interface.....	6
3.1	Control options.....	6
3.2	Card-Edge Status LED	6
4	Local control using the Densité frame control panel	7
4.1	Menu for local control.....	8
5	Remote control using iControl.....	9
5.1	The iControl graphic interface window.....	9
5.2	Gateway Config panel.....	12
5.2.1	Gateway Config panel – System tab	12
5.2.2	Gateway Config panel – Gateways tab	13
5.2.3	Gateway Config panel – Names tab	15
5.3	Network Config panel.....	15
5.3.1	Network Config panel – Settings tab	15
5.3.2	Network Config panel – Status tab	16
5.3.3	Network Config panel – Statistics tab	16
5.4	Gateway Status panel.....	17
5.5	Reference Panel	17
5.6	Test panel	19
5.7	Factory/Presets Panel.....	19
5.7.1	Factory	20
5.7.2	Profiles	20
5.8	Alarm Config Panel	23
5.9	Info Panel	26
5.9.1	Info Panel – Info tab	26
5.9.2	Info Panel – Technical Support tab.....	27
6	Specifications.....	28
7	Contact Us.....	29
	Grass Valley Technical Support.....	29
	Corporate Head Office	29
	ANNEX – Local Menu.....	30

GUIDE TO INSTALLATION AND OPERATION

1 IPG-3901 High Density SDI/IP Gateway for Densité 3 Platform

1.1 Introduction

The Densité IP Gateway (IPG-3901) plug-and-play modules seamlessly bridge hybrid SDI/IP production environments. As broadcasters migrate to IP-based transport, these space-saving, low-power cards are easily added to existing Densité signal processing platforms, converting real-time, uncompressed, baseband video using SMPTE 2022-6 protocol for distribution over 10 GigE networks, and vice versa.

The gateways support any mix of 3G/HD/SD-SDI production workflows over IP networks. With bidirectional I/O in combinations of 5 in/6 out or 6 in/5 out, the cards offer full redundancy in either unicast or multicast workflows to ensure uninterrupted service.

Based on the proven Densité modular framework of over 100 functional cards, the flexible, space-efficient IPG-3901 cards accommodate a gradual adoption of IP production elements into broadcasting workflows, while protecting operational methods and investment in installed equipment. With flexibility to configure up to 6 IPG-3901 modules per Densité 3 frame and with each IPG-3901 module carrying 11 HD or 6 3G gateways, the Densité 3 platform scales to a density of 66 HD or 36 3G gateways in a 3 RU frame. In the new Densité 3+ FR4 frame, up to 12 IPG-3901 modules can be installed giving a density of 132 HD or 72 3G gateways in a 4 RU frame. This means space- and cost-efficient scaling – today and tomorrow.

The Densité IP Gateway can be controlled by the advanced GV Convergent SDN platform, offering unified control across COTS IP switches and SDI routing/processing infrastructures, as well as by the proven iControl systems.

1.2 Features

- High density configuration with 11 gateways per card – 66 gateways per 3 RU Densité 3 frame or 132 gateways per 4 RU frame in the new Densité 3+ FR4
- De-encapsulate full bandwidth uncompressed SMPTE 2022-6 to SDI
- Encapsulate SDI into full bandwidth uncompressed SMPTE 2022-6 IP
- Bidirectional transport of SD/HD/3G-SDI video signals over 10 GigE link
- Full 1+1 stream redundancy with automatic change-over link to avoid service interruption
- Bidirectional I/O for 5/6 inputs and 5/6 outputs for up to 11 streams
- Compatible with Densité 3 platform (3 slots in Densité 3 or 2 slots in Densité 3+ frames)
- Integrates with iControl and GV Convergent SDN control frameworks
- IGMPv3 support for IP inputs
- Supports unicast and multicast signals
- Features dual-network interfaces supporting 10 GigE SFP+:
 - Short range multi-mode optical
 - Long range single-mode optical
- Flexible HD/SD/URS reference input

1.3 Functional Block Diagram

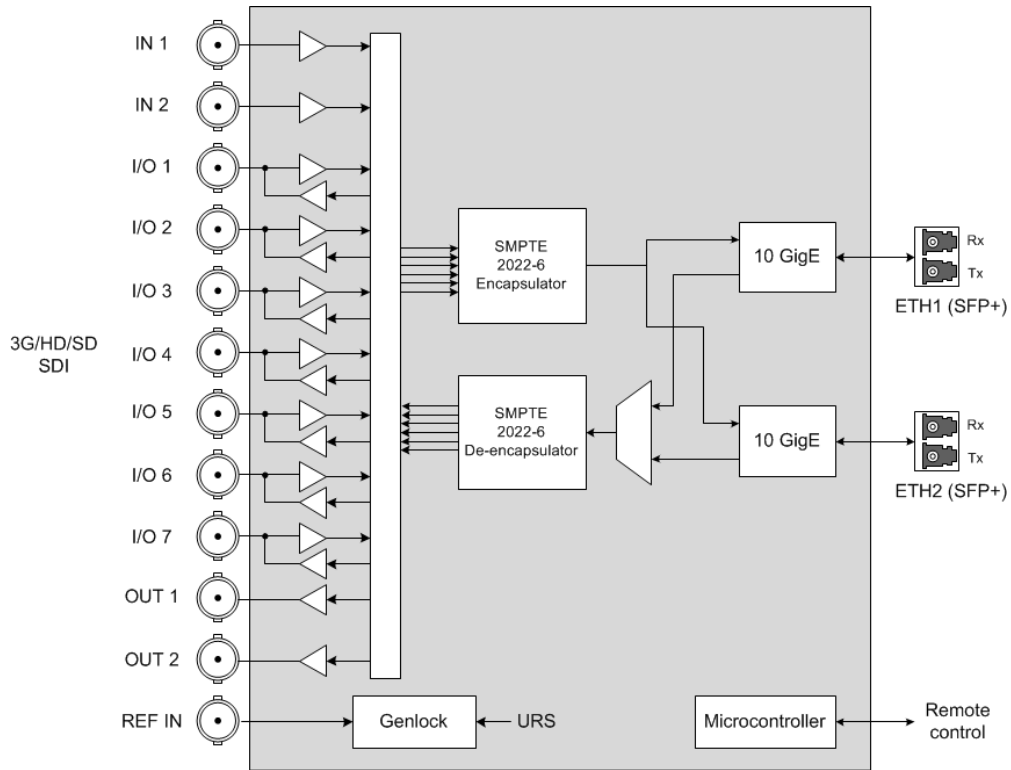

Figure 1-1 IPG-3901 Functional Block Diagram

1.4 Front Card-edge Interface

The front card-edge of the IPG-3901 incorporates two elements:

- [Status LED](#) (see section 3.2)
- [Select Button](#) (see section 4)

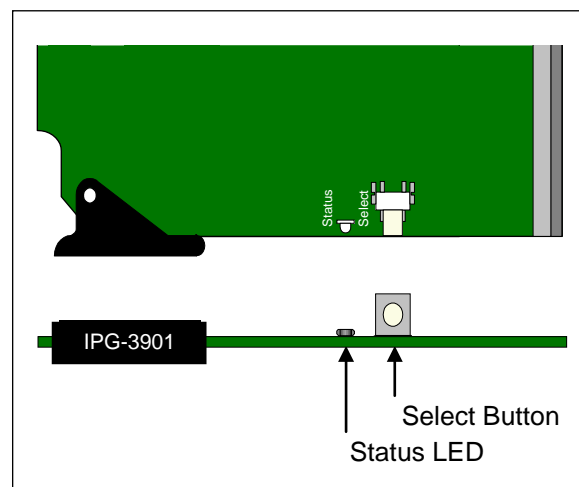

Figure 1-2 Front card-edge layout

2 Installation

2.1 Installation of Rear Connector Panels

Grass Valley Densité-series cards are each associated with a rear connector panel, which must be installed in the Densité frame before the card can be inserted.

The IPG-3901 card is designed to fit into Grass Valley's Densité-3 and Densité 3+ frames. Two different rear connector panels are available:

- IPG-3901-3TRP Triple-slot-width panel for Densité-3
- IPG-3901-3+DRP Double-slot-width panel for Densité-3+FR1 and Densité-3+FR4

See [section 2.3](#) for details of the signal connections available on these panels.

All cards and rear panels can be installed with the frame power on. The card has connectors that plug into a mid-frame mother board for distribution of power and for connection to the controller card, and a second connector that plugs directly into the rear connector panel for input and output.



The rear connector panel must be installed with the card out of the frame.

- To remove an existing card from the slot, tilt the swivel handle on the front of the card to lever the connectors apart, then use the handle to pull the card straight out of the slot.

To install the connector panel:

1. If a card is installed in the slot whose rear panel is being changed, remove it as described above.
2. Remove the existing panel (either blank or belonging to an existing card that is being changed) by releasing the captive screw(s) at the bottom (Densité 3 or Densité 3+ FR4) or side (Densité 3+ FR1) of the panel.
3. Position the new panel and secure it in place with the captive screw(s) at the bottom or side.

2.2 IPG-3901 Card Installation

Once a matching rear connector panel is in place, install the IPG-3901 card as follows:

1. Open the front panel of the frame.
2. Slide the IPG-3901 card into the slot and push gently on the handle to seat the connectors.
 - When using a triple-slot-width rear panel in a Densité-3 frame, the card should be inserted into the rightmost of the three slots.
 - When using a double-slot-width rear panel in a Densité-3+ FR1 frame, the card should be inserted into the lower of the two slots.
 - When using a double-slot-width rear panel in a Densité-3+ FR4 frame, the card should be inserted into the rightmost of the two slots.

Inserting the card into the wrong slot will not damage the card, and will be flagged by the on-card status LED flashing red to indicate that there is no connection to the rear panel.

3. Close the front door of the frame.

2.3 Rear Panels and Connectors

2.3.1 Images of Rear Panel Connectors

The two available rear panels are shown in the figure. Details of the inputs and outputs are described below.

NB – references to MAD I on the labels for I/O 1, 3, 4 and 7 are for future use.

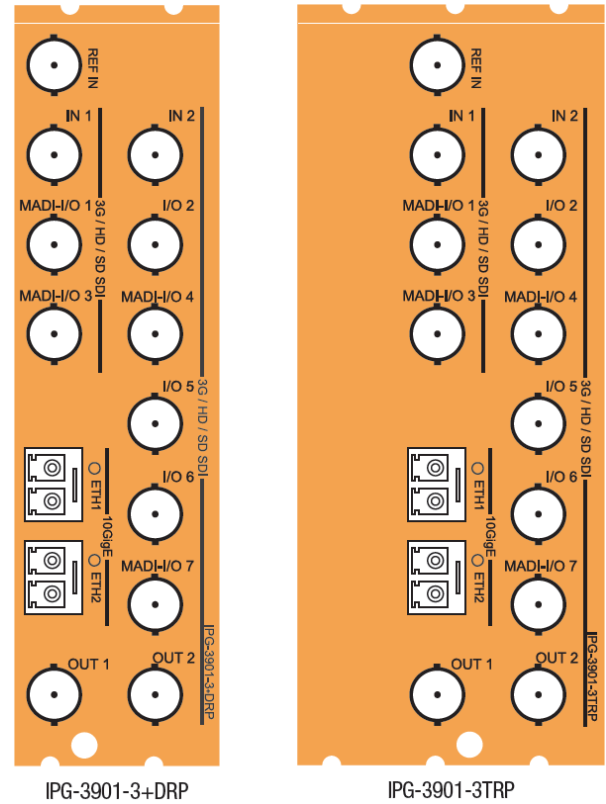

Figure 2-1 IPG-3901 Rear Panels

2.3.2 Summary of rear panel connections

IPG-3901-3TRP		
IPG-3901-3+DRP		
Double-slot-width panel for Densité 3+ FR1 and FR4 frames	◆	
Triple-slot-width panel for Densité 3 frame		◆
CONNECTORS		
Reference IN	1	1
3G/HD/SD SDI IN	2	2
3G/HD/SD SDI OUT	2	2
3G/HD/SD SDI I/O configurable	7	7
10 GigE Ethernet on fiber (SFP+)	2	2

2.3.3 Details of rear panel connections

REF IN – External reference

Connect an NTSC or PAL reference signal (SMPTE 170M / SMPTE 318M / ITU 624-4 black burst)

3G/HD/SD IN – Serial digital 3G/HD/SD inputs

Connect serial digital video signals, conforming to the SMPTE 425M standard for 3G input signals, SMPTE 292M standard for HD input signals or SMPTE 259M standard for SD input signals, to the connectors labeled **3G/HD/SD IN 1 and IN 2**.

3G/HD/SD OUT – Serial digital video outputs

The IPG-3901 provides two 3G/HD/SD SDI video outputs on the connectors labeled **3G/HD/SD OUT 1 and 2**. The SDI video signal conforms to the input standard. The same signal is carried on both outputs.

3G/HD/SD SDI I/O – Serial digital 3G/HD/SD input or output (configurable)

Seven configurable I/O are provided. The SDI signal requirements are the same as those for the dedicated inputs and outputs as described above.

10 GbE ETH – 10 GigE Ethernet on fiber (SFP+ Interfaces)

Two 10 Gb Ethernet interfaces (each with Tx and Rx) on optical fiber or twinax cable. SFP+ modules and matching fiber or electrical connectors are required for the interface.

3 User Interface

3.1 Control options

The IPG-3901 can be controlled in two different ways:

- The local control panel and its push-buttons can be used to move through a menu of status reports (see [section 4](#)).
- Grass Valley's iControl system can be used to access the card's operating parameters from a remote computer, using a convenient graphical user interface (GUI) (see [section 5](#)).

3.2 Card-Edge Status LED

The status monitor LED is located on the front card-edge of the IPG-3901, and is visible through the front access door of the DENSITÉ 3 frame. This multi-color LED indicates the status of the IPG-3901 by color, and by flashing/steady illumination.

The chart shows how the various error conditions that can be flagged on the IPG-3901 affect the LED status.

- If a cell is gray, the error condition cannot cause the LED to assume that status
- If more than one LED status is possible for a particular error condition, the status is configurable.
See [Alarm Config Panel](#) for details.
- The factory default status, if available, is shown by a ⚙

The LED will always show the most severe detected error status that it is configured to display, and in the chart error severity increases from left to right, with green representing no error/disabled, and flashing red the most severe error.

If the LED is Flashing Yellow, it means that the card is selected for local control using the Densité 3 frame's control panel. See [section 4](#) for details.



Error Condition	LED Status			
	Green	Yellow	Red	Flashing Red
Hardware failure – cooling fans				⚙
Wrong or missing Rear				⚙
Ethernet Port 1 Link Status			⚙	
Ethernet Port 2 Link Status	⚙			
Internal test pattern enabled		⚙		
Overall Gateway Status			⚙	

4 Local control using the Densité frame control panel

Push the SELECT button on the IPG-3901 card edge (see Section 1.4) to assign the local control panel to operate the IPG-3901. Use the control panel buttons to navigate through the menu, as described below.

- The complete menu structure is shown in the Annex to this document, beginning on page 30.

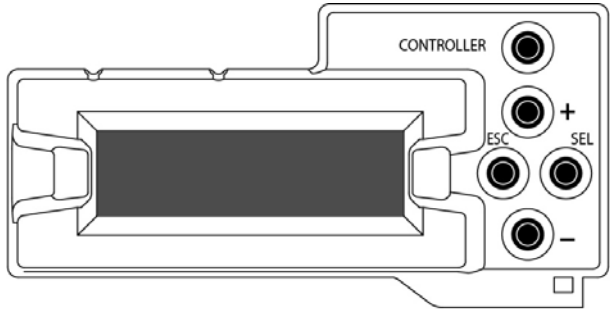
There are two types of local control panel:

Panel type	Frame models	Appearance
Physical	Densité-3, Densité-3+FR1,	
Touch screen	Densité 3+FR4, GV Node	

The local control panel is fastened to the front of the controller card.

- The physical panel is accessed by opening the front door of the frame.
- The touch screen panel is accessed through an aperture in the frame door.

The panel consists of a display capable of displaying two lines of text, each 16 characters in length, and four pushbuttons.

Assign the panel to operate the IPG-3901 by pushing the SELECT button on the front edge of the IPG-3901 card.

- The STATUS LED on the IPG-3901 flashes yellow.

The local control panel displays a menu that can be navigated using the four pushbuttons located beside the display. The functionality of the pushbuttons is as follows:

[+] [-] Used for menu navigation and value modification

[SELECT] Gives access to the next menu level. When a parameter value is shown, pushing this button once enables modification of the value using the [+] and [-] buttons; a second push confirms the new value

[ESC] Cancels the effect of parameter value changes that have not been confirmed; pushing [ESC] causes the parameter to revert to its former value.

Pushing [ESC] moves the user back up to the previous menu level. At the main menu, [ESC] does *not* exit the menu system. To exit, re-push the [SELECT] button for the card being controlled.

If no controls are operated for 30 seconds, the controller reverts to its normal standby status, and the selected card's STATUS LED reverts to its normal operating mode.

4.1 Menu for local control

The IPG-3901 has operating parameters that may be adjusted locally at the controller card interface.

- Press the SELECT button on the IPG-3901 front card edge to assign the Densité frame's local control panel to the IPG-3901
- Use the keys on the local control panel to step through the displayed menu to configure and adjust the IPG-3901
- See the [ANNEX - Local Menu](#) for a complete menu listing.

5 Remote control using iControl

The operation of the IPG-3901 may be controlled using Grass Valley's iControl system.

- This manual describes the control panels associated with the IPG-3901 and their use.
- Please consult the iControl User's Guide for information about setting up and operating iControl.

In iControl Navigator or iControl Websites, double-click on the IPG-3901 icon to open the control panel.

5.1 The iControl graphic interface window

The basic window structure for the IPG-3901 is shown in figure 5.1. The window identification line gives the card type (IPG-3901) and the slot number where the card is installed in its Densité frame.

There are four main sections in the window itself, as identified in the figure:

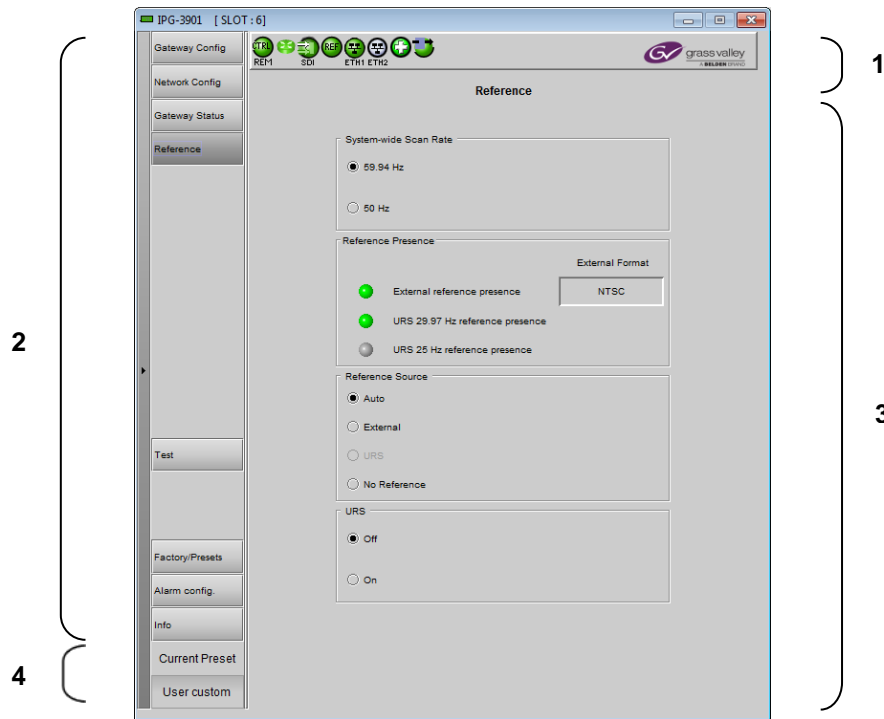

Figure 5-1 IPG-3901 iControl graphic interface window

Section 1. The top section displays eight icons on the left. These icons report different statuses such as card communication status, gateway status, health status, and card operation mode.



Icon # 1 2 3 4 5 6 7 8

Move the mouse over an icon and a status message appears below the icon providing additional information. If there is an error, the error status message appears in the message area without mouse-over.









- If there are multiple errors, the error messages cycle so all can be seen











- The icon whose status or error message is shown is highlighted with a mauve background

The table below describes the various status icons that can appear, and how they are to be interpreted.

- In cases where there is more than one possible interpretation, read the error message in the iControl window to see which applies.

Table – iControl Status Icon interpretation

Icon #1 – Manual Card Configuration	
 (green)	Remote card control activated. The iControl interface can be used to operate the card.
 (yellow)	Local card control active, The card is being controlled using the Densité frame control panel, as described in section 4 . Any changes made using the iControl interface will have no effect on the card.
Icon #2 – Gateway status	
 (green)	All gateways are OK.
 (red)	At least one gateway is down.
Icon #3 – SDI Input Status	
 (green)	All SDI inputs detected and valid.
 (red)	At least one SDI input is in error. Reference mismatch. Video/TRS error.
Icon #4 – Reference Status	
 (green)	Reference present, supported and locked.
 (red)	Reference missing. Unsupported format or format mismatch. Not locked.
 (gray)	No reference.

Icon #5 – ETH1 Status	
 (green)	<i>IP link up and active.</i>
 (red)	<i>No link (port down).</i>
Icon #6 – ETH2 Status	
 (green)	<i>IP link up and active.</i>
 (red)	<i>No link (port down).</i>
 (gray)	<i>Ethernet port not used.</i>
Icon #7 – Health Monitoring	
 (green)	<i>Hardware OK.</i>
 (red)	<i>Hardware Health Monitoring (Hardware fault detected). FPGA overheating and has been disabled. If this icon appears flashing red, you need to change the FPGA FAN and/or DSP FAN.</i>
Icon #8 – Operation Mode	
 (green)	<i>Operation mode: process – normal processing of the input signal.</i>
 (yellow)	<i>Operation mode: Enabled, but no signal to process.</i>
 (yellow)	<i>Operation mode: TEST – color bar and audio test tones enabled on at least one gateway.</i>

Section 2. The left portion of the window contains selection buttons for all of the individual panels, which become highlighted when they are selected. The main window section (3) then displays the selected panel.

Section 3. The main section displays the panel selected in section 2. It may contain multiple tabs to access any appropriate sub-panels.

Section 4. The lower left corner of the window identifies the Preset currently in use or “Custom” if none is applicable.

Each of the panels accessed from the buttons in Section 2, and shown in Section 3, is described individually in the following sections.

5.2 Gateway Config panel

5.2.1 Gateway Config panel – System tab

Receiver FIFO Level (Packets):

This setting determines the number of packets retained in the input buffer (FIFO).

Generally, IP data streams passing through a network with multiple switches will suffer from “packet jitter”, which must be processed out in a buffer before conversion to a continuous SDI video signal. If the necessary packets have not been received before conversion, dropouts will appear in the video. The larger the buffer, the more likely all the necessary packets will have been received, but the buffer adds latency to the processing, which is not desirable.



Figure 5-2 Gateway Config - System

The object is to achieve error-free video with the lowest buffer size.

Use the slider, or type directly into the data box, to set the buffer size.

Receiver FIFO level	
Range:	3 to 32 packets
Default:	4 packets

Output on Error: Specify the output behavior of the system when an invalid input is detected

Mode	Behavior												
Kill	Turn the output OFF [DEFAULT]												
Configurable color slate	<p>Output a signal in the appropriate format, with the picture being a full-screen color as shown in the sample box beside the pulldown.</p> <p>The color is configurable:</p> <ol style="list-style-type: none"> Click on the color sample to open the Color Selection window. In the Color Selection window, use the sliders, or type directly into the data boxes, to select a color. <div style="display: flex; align-items: flex-start;"> <div style="margin-right: 20px;"> </div> <table border="1"> <thead> <tr> <th>Component</th> <th>Range</th> <th>Default</th> </tr> </thead> <tbody> <tr> <td>Y</td> <td>1-254</td> <td>16</td> </tr> <tr> <td>Cb</td> <td>1-254</td> <td>128</td> </tr> <tr> <td>Cr</td> <td>1-254</td> <td>128</td> </tr> </tbody> </table> </div> <ol style="list-style-type: none"> If the selected color is an invalid system color it will be flagged in the Color Selection window and in the color sample box. Select <i>Default</i> to choose the system default color (Black: 12, 128, 128) and leave the Color Selection window open. Select <i>Apply</i> to accept the selected color and leave the Color Selection window open. Select <i>OK</i> to accept the selected color and close the Color Selection window. Select <i>Cancel</i> to close the Color Selection window without making changes. 	Component	Range	Default	Y	1-254	16	Cb	1-254	128	Cr	1-254	128
Component	Range	Default											
Y	1-254	16											
Cb	1-254	128											
Cr	1-254	128											

5.2.2 Gateway Config panel – Gateways tab

This page shows the current configuration of all 11 gateways on the card, and provides controls to modify the configuration.

- **Enable/Disable** a gateway by clicking the selection checkbox in the leftmost column (“En”) of the table.
- **Select** a gateway by clicking anywhere in its row in the table.
- **Edit** the configuration of the selected gateway using the controls at the bottom.

The table in the panel shows the following:

- En. – checkbox showing enable status
- SDI I/O – 1st line: Name of gateway (fixed)
2nd line: Gateway name (set in Names tab)
- Dir – the arrow shows the direction of signal flow between SDI and IP through the gateway.
- Format: The (non-specific) signal format: (SD, HD, 3G)

The following two entries show two rows each:

- Top row – primary stream information
- Bottom row – redundant stream information

- Stream Address – The IP address (source or destination, depending on the direction of signal flow) of the stream (unicast or multicast). In this table, the port is shown appended to the address (IP:port)
- IGMPv3 Source – Useful only when IGMP is used. In this protocol, the card deals with a switch to subscribe to one or many streams coming from different IP addresses. When IGMP is used, the field “stream address” is used to talk to a “group” while the “stream source” indicates the exact source from which we want to receive the stream.

Note that only one gateway at a time can be fed by a “socket” (stream IP address + port).

The status of the IP stream is shown by the background color of the Stream Address column.

Gateway Direction	Color	Status
IP Stream to SDI	Green	IP stream is valid
	Red	Invalid address No IP stream Errors in IP stream
	Grey	Gateway disabled

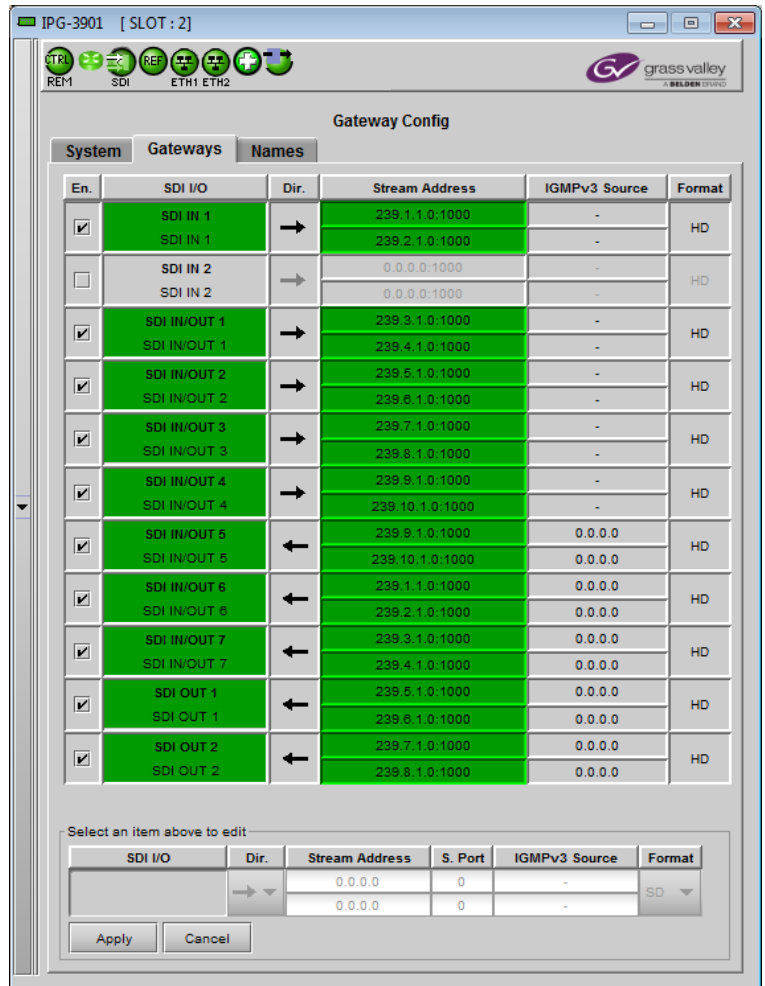

Figure 5-3 Gateway Config panel – Gateways tab

Gateway Direction	Color	Status
SDI to IP Stream	Green	Normal operations
	Orange	Not a valid multicast or unicast address
	Red	SDI input errors SDI scan rate error SDI format error
	Grey	Gateway disabled

The status of the Gateway is shown by the background color of the SDI I/O column:

Color	Status
Green	Input video is present Generating a valid output
Red	Input video format mismatch Error No input Not generating an output
Gray	Gateway is disabled

The edit box allows the following parameters to be set for the selected gateway:

Parameter	Values	Default value	Notes
Direction (Dir.)	→ (SDI to IP Stream) ← (IP Stream to SDI)	→ (SDI to IP Stream)	SDI IN 1 and 2 are hard-coded inputs SDI OUT 1 and 2 hard-coded outputs
Stream Address	0.0.0.0 to 255.255.255.255	0.0.0.0	<u>SDI to IP Stream</u> 0.0.0.0 and 255.255.255.255 are refused (not applied) <u>IP Stream to SDI</u> Multicast address are accepted (224.0.0.0 through 239.255.255.255) Unicast address are accepted
Stream Port (S. Port)	0 to 9999	1000	
IGMPv3 Source	0.0.0.0 to 255.255.255.255	0.0.0.0	
R. Stream Address	0.0.0.0 to 255.255.255.255	0.0.0.0	<u>SDI to IP Stream</u> 0.0.0.0 and 255.255.255.255 are refused (not applied) <u>IP Stream to SDI</u> Multicast address are accepted (224.0.0.0 through 239.255.255.255) Unicast address are accepted
R. Stream Port (S. Port)	0 to 9999	1000	
R. IGMPv3 Source	0.0.0.0 to 255.255.255.255	0.0.0.0	
Format	SD, HD, 3G	HD	

5.2.3 Gateway Config panel – Names tab

The table shows the eleven SDI I/Os, and the user can edit the name for each in the *Gateway Name* column.

1. Select the text to be changed
2. Type the new text
3. *Apply* to accept the revised text, or *Cancel* to discard the changes

The Gateway Name is shown as the second text line in the SDI I/O column in both the *Gateway Config – Gateways* panel, and the *Gateway Status* panel.

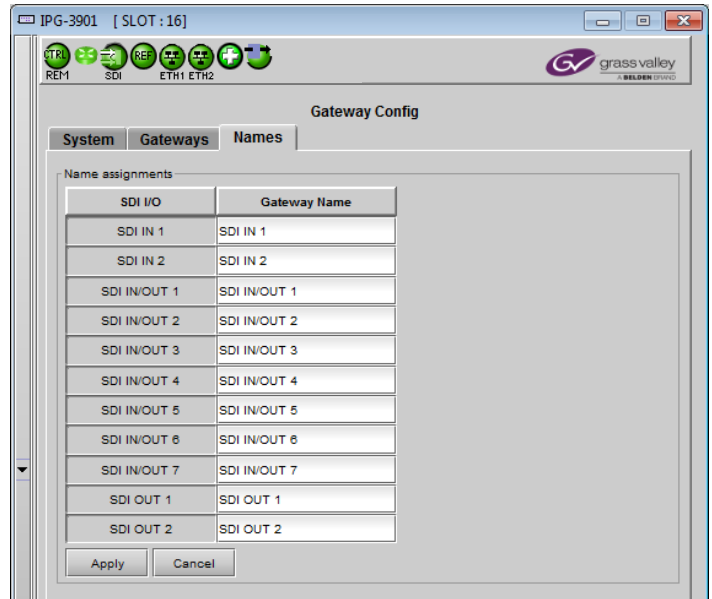
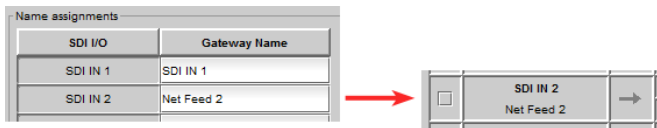

Figure 5-4 Gateway Config panel – Names tab

5.3 Network Config panel

5.3.1 Network Config panel – Settings tab

Network Configuration

Enter the IP Address, Mask and Gateway for the two ethernet ports (ETH1 and ETH2) on the IPG-3901 into the data boxes.

- After any change, you must click *Apply* to confirm the new values, or *Cancel* to leave the existing values unchanged. Pending changes are displayed in red.

Note that the two IP addresses configured in this panel should NOT be in the same subset.

Enabled (ETH 2 Port): The ETH 2 port is used to provide redundancy. If redundancy is not required, disable the port by unselecting this box. This will prevent unnecessary error messages from being displayed.

Test Address

Type a proposed destination address into the data box, and click *Ping* to check whether the destination can be seen by this port.

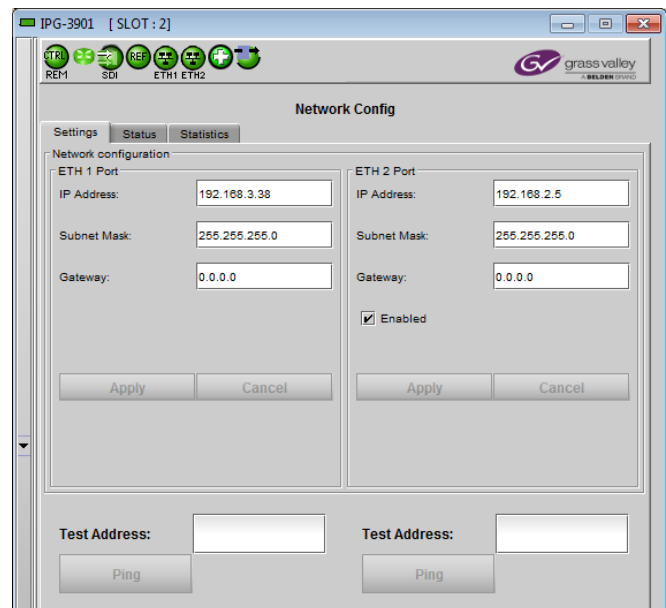

Figure 5-5 Network panel – Settings tab

5.3.2 Network Config panel – Status tab

This tab reports on the status of the ETH1 and ETH2 ports.

Status	Details
Link	The icon indicates the link status: Green – up and valid Grey - down
IP Address	As set in the Settings tab
Subnet Mask	As set in the Settings tab
Gateway	As set in the Settings tab
MAC Address	Each port has a separate MAC address, factory-set and non-configurable.
SFP Presence	Green – supported SFP detected Grey – no supported SFP detected

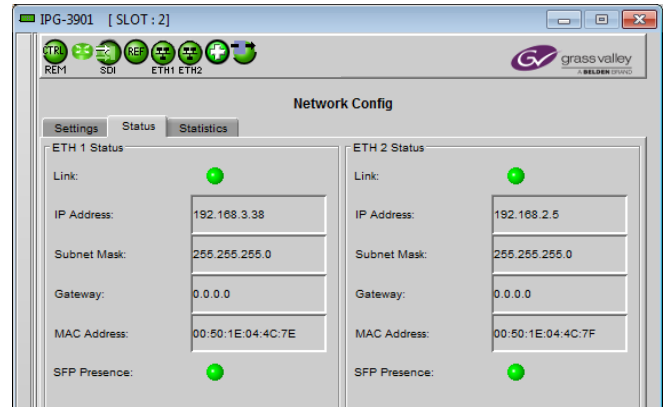

Figure 5-6 Network panel – Status tab

There are no operating controls or settings on this tab.

5.3.3 Network Config panel – Statistics tab

This tab displays continuously-updated statistics about the data passing through each of the ethernet ports.

- Packets: The total number of Ethernet packets transmitted and received since the last reset on each port.
- Errors: The total number of Rx and Tx errors detected on each ethernet port since the last reset.

The accumulated statistics can be reset for a fresh start by clicking the *Reset ETH Statistics* button

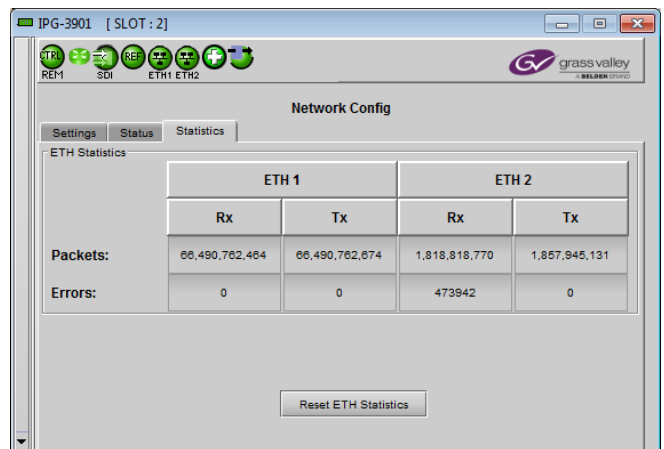

Figure 5-7 Network panel – Statistics tab

5.4 Gateway Status panel

The table reports the status of the eleven gateways on the card. Seven columns report on each gateway:

- **St** – The status icon is green (OK) if the status of both the SDI I/O and Stream Address columns is OK (see the notes on color coding below); otherwise it will be red (error condition) or gray (gateway unused)
- **SDI I/O** – The background color shows the status – see below.
- **Dir** – the arrow shows the direction of signal flow through the gateway.
- **Stream Address** – the IP address (source or destination, depending on the direction of signal flow) of the stream (unicast or multicast). The background color shows the status – see below.
- **Port** – a label for the Sel column
- **Sel** – indicates which ports are selected for the current function – both when the IP is the destination; only the active one when IP is the gateway input.
- **Format** – shows the specific format of the signal, or “no signal”

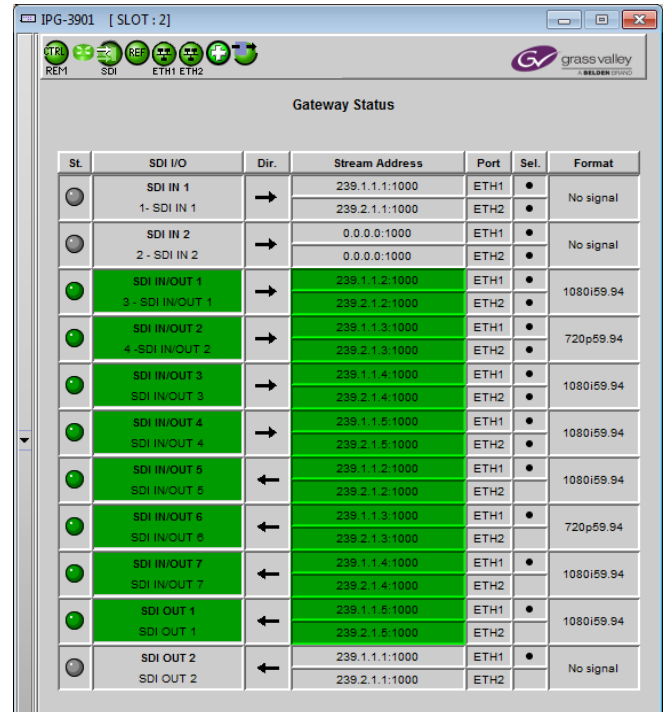

Figure 5-8 Gateway Status panel

The status of the IP stream is shown by the background color of the Stream IP Address column. This is the same as the color coding in the Gateway Config – Gateways panel

- IP Input: Green Transport Stream is present
Red No stream at the IP address
- IP Output: Green Normal operation
Orange No route to host IP
(In unicast streaming, this means that the specified unicast address is unreachable)

The status of the SDI I/O is shown by the background color of the Gateway column when the SDI side is selected as INPUT using the direction arrow.

- SDI Input: Green Transport stream present
Red No transport stream at the SDI input
- SDI Output: Gray The background is always gray for an SDI output

5.5 Reference Panel

This panel allows the selection of the reference to be used by the IPG-3901.

System-wide Scan Rate: Use the pulldown to select the scan rate for the system.

Scan rate
50 Hz
59.94 Hz

- Any input not matching this rate will be considered invalid.
- Any reference not matching this rate will be considered a ref-mismatch.

Reference Presence – the icons show the presence and status of the various reference sources. For the external reference, the format is shown in the External Format window.

Icon	Carrier	Format
Grey	None or not valid	N/A
Yellow	Present & valid	Valid, but not supported
Green	Present & valid	Valid and supported

External Format	Supported
NTSC	Yes
PAL	Yes
1080i59HZ	(future)
1080i50HZ	(future)
720p59Hz	(future)
720p50Hz	(future)

Reference Source – use the radio buttons to select from the following options:

Reference Source	Description	Default
Auto	This mode selects the first source detected in this order of priority: 1. External Reference input 2. URS 3. Selected Input signal	Auto
External	Selects the signal connected to the rear-panel REF IN connector	
URS (Universal Reference Signal)	(Universal Reference Signal) selects the internal reference from the Densité frame's backplane	
No Reference	SDI outputs are synchronized to their respective IP stream.	

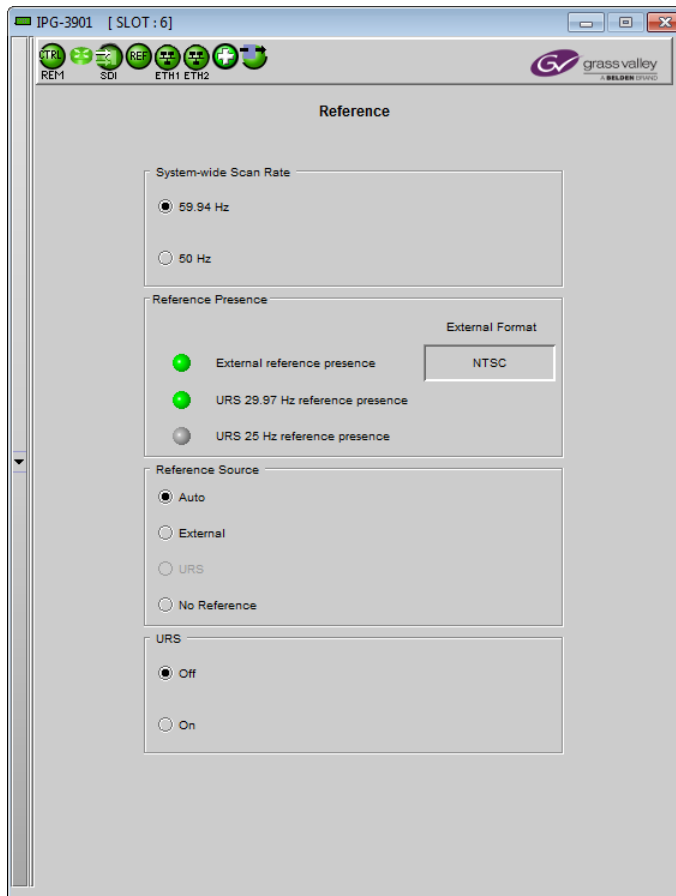

Figure 5-9 Reference panel

Note – The SDI Outputs (only) are synchronized to the selected reference, but they are not phase-locked.

URS Format – use the radio buttons in the URS area to select whether the URS is OFF or ON.

URS	Description		
OFF	URS cannot be selected as the reference source and is ignored by the Auto detection mode		
ON	URS is available, and related to the system-wide scan rate :		
		Scan rate	URS
		59.94 Hz	29.97 Hz
50 Hz	25 Hz		

5.6 Test panel

The test generator can be selected by the user to appear on any output (SDI and stream).

Test Pattern Generator Format

Select the test pattern format using the pulldown.

Format
SD
720p
1080i

The pattern will be generated at the System-wide Scan Rate, as specified in the *Gateway Config/System* panel.

- The current value is displayed in this panel at the top of the table, for reference
- The generator will be synchronous to the REF IN if available; otherwise it will be free-run.

Select the **Test Pattern** checkbox beside a gateway to force the test pattern onto that output.

Select the **Force All** checkbox to force the test pattern onto all outputs.

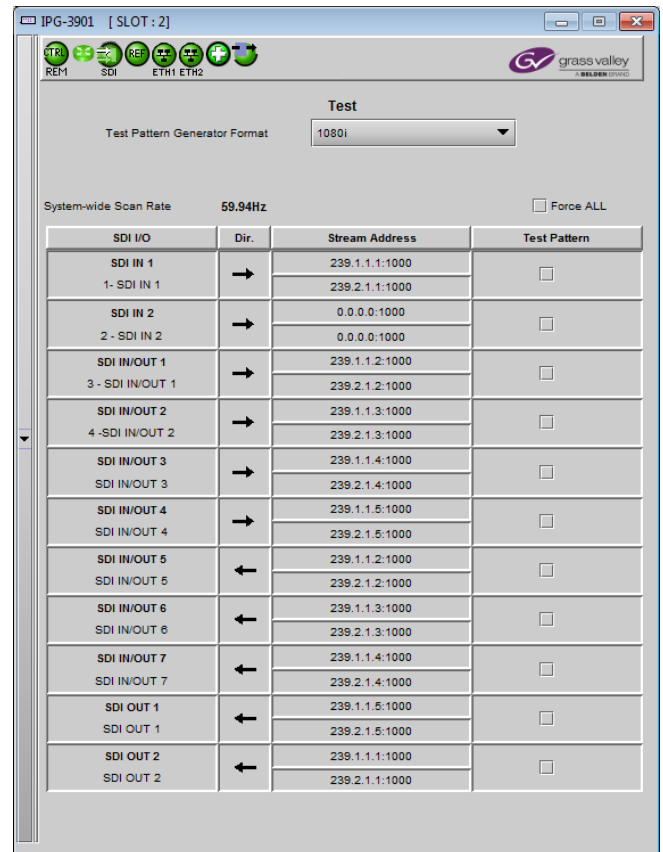

Figure 5-10 Test panel

5.7 Factory/Presets Panel

User Presets

The IPG-3901 has memory registers which can hold up to 5 user-defined parameter settings.

Select any one of the five presets using the Card Preset Select pull-down.

Click **Load** to load the contents of the selected User Preset into the IPG-3901. All parameter settings and values will be replaced by the contents of the selected User Preset.

A confirmation box will pop up to allow you to proceed or cancel the load.

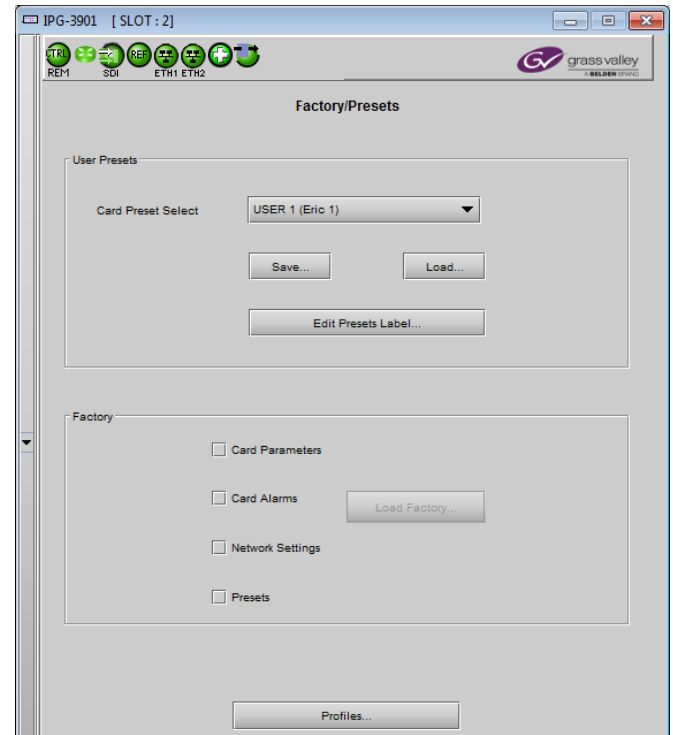
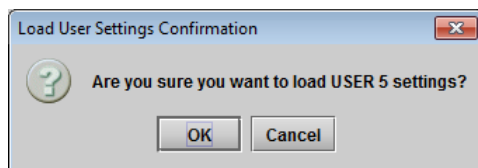
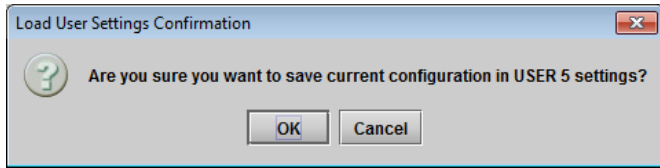

Figure 5-11 Factory/Presets Panel

Click **Save** to store the current parameter settings and values from the IPG-3901 into the selected User Preset. The existing contents of the preset will be overwritten. A confirmation box will pop up to allow you to proceed or cancel the save.



You can edit the name assigned to each user preset.

- Click Edit Presets Label to open the Presets window.
- Double-click on a name in the Label column
- Type a new name in the window.
- Click OK

The text you have entered (up to 16 characters) will be appended to the label name in the selection pulldown

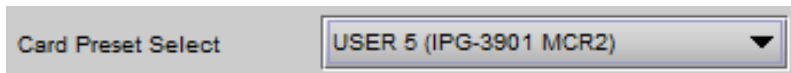

5.7.1 Factory

Clicking the Load Factory button will restore the card to a factory default state. Four checkboxes enable the user to choose whether to include Card Parameters, Card Alarms, Network Settings and Presets in the restoration process

- Exception – the “Network Config” and Gateway names will remain unchanged.

Note – Card Alarms only are reset to factory values; iControl Alarms and GSM alarms are not reset. With reference to the Alarm Configuration panel:

Reset by Load Factory?

Yes

No

No

Status / Name	Card LED	Overall alarm	GSM contribution	Log eve...
IPG-3901	Set all	Set all	Set all	<input checked="" type="checkbox"/>
Gateway_Global_Status	Set all	Set all	Set all	<input checked="" type="checkbox"/>
Color Bars	Minor	Disabled	Disabled	<input checked="" type="checkbox"/>
Global SDI Stream Presence	Critical	Disabled	Disabled	<input checked="" type="checkbox"/>
Global Gateway Status	Critical	Disabled	Disabled	<input checked="" type="checkbox"/>

5.7.2 Profiles

Use *Profiles* to save or recover the entire card configuration (including user presets if desired) on an external disk, or to copy it to another IPG-3901 card.

Click on *Profiles* to open the Profile Copy window.

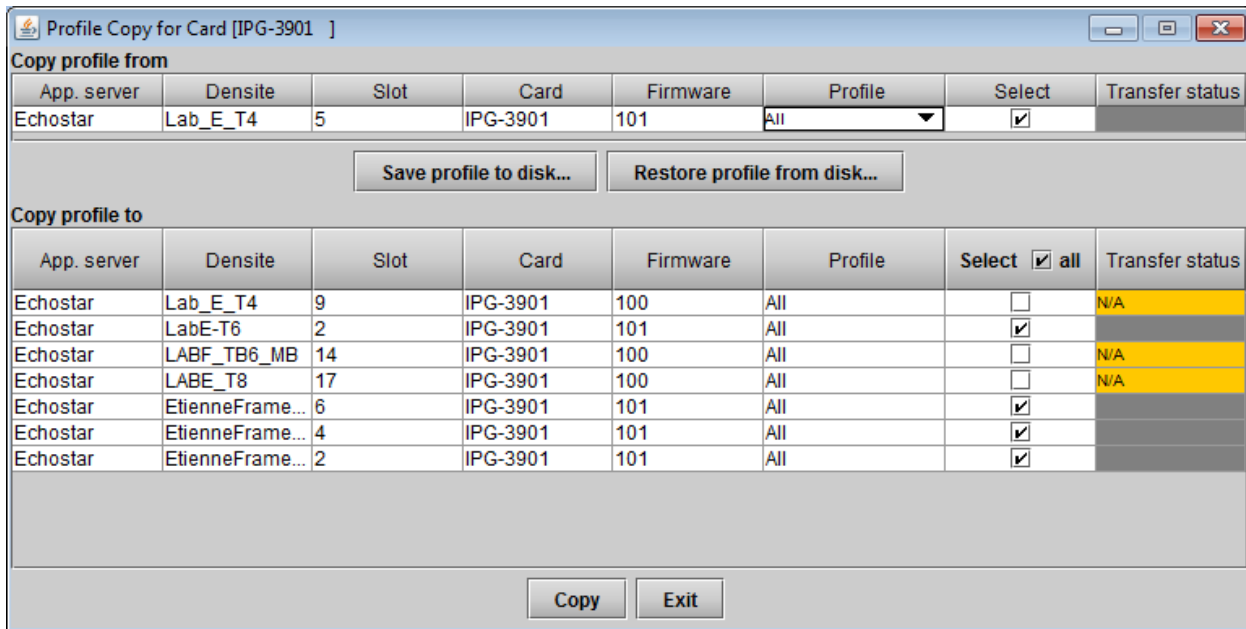

Figure 5-12 Profile Copy for Card

Copy profile from

This line shows this IPG-3901 card, and identifies it by App server, Densité frame and slot number, card type and firmware version.

The *Profile* column has a pulldown that allows you to select which profiles you will work with, and gives these choices:

- All, Current, User1, User2, User3, User4, User5

Profile	Values	Default
ALL	Current configuration of the card and all presets will be copied or saved on disk	ALL
Current	Only the current configuration of the card is copied or saved on disk	
User1 ...User5	Only the selected preset will be copied or saved on disk	

The *Select* column includes a checkbox (preselected checked) to confirm that you want to work with the current card.

Save Profile to Disk...

After selecting which profiles you want to save, click this button to open a Save dialog allowing you to specify a file name and location to which the selected profiles for this card will be saved.

Hint - It is a good idea to create a folder for these files, because they are not explicitly identified as IPG-3901 profiles, and will be difficult to find and identify if not clearly named and conveniently located.

- Click the save button once the name and location have been identified in the Save box. The Transfer Status box on the right of the *Copy profile from* line will indicate *In progress* against a yellow background.



- If the file is saved correctly, the Transfer Status box will indicate *Succeeded* against a green background.

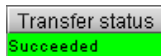

- If the file was not saved for some reason, the Transfer Status box will indicate *Failed* against a red background.



Restore profile from disk...

Click this button to open an *Open* dialog box within which you can locate and select a valid IPG-3901 profile file.

- Click Open to read the contents of the file and to reconfigure this IPG-3901's profiles according to its contents
- While the reconfiguration is in progress, the Transfer Status box on the right of the *Copy profile from* line will indicate *Working* against a yellow background
- When the reconfiguration is complete, the Transfer Status box will indicate *Succeeded* against a green background

On a restore profile from disk, there is no need to select a profile type (ALL, Current, User1 to User5). All the profile contents of the file will be restored.

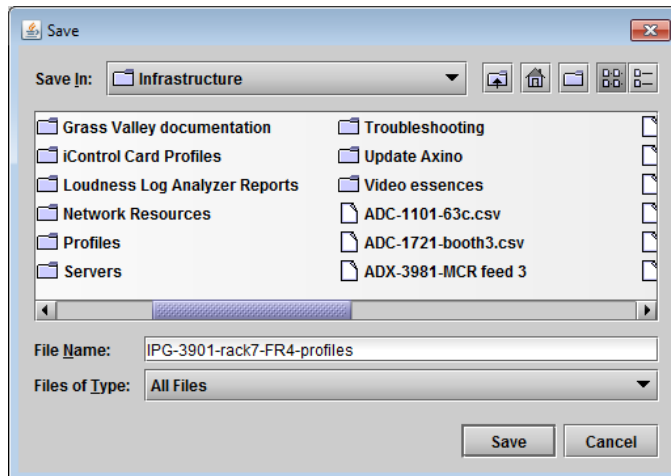

Figure 5-13 Save Profile to Disk dialog

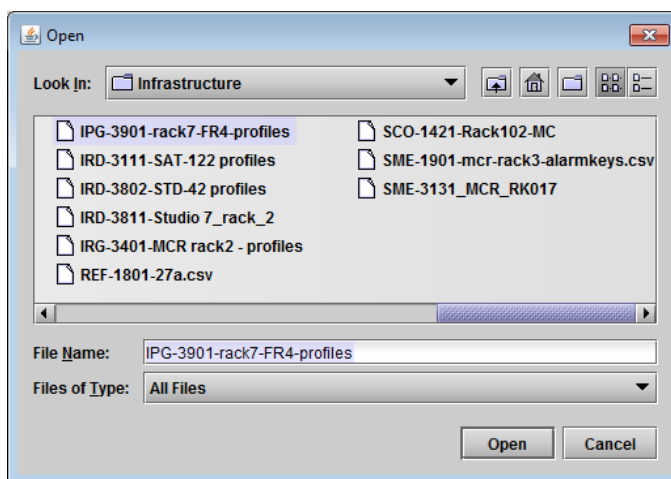

Figure 5-14 Restore Profiles from Disk dialog

Copy profile to

This section shows other IPG-3901 cards that are available on the iControl network, each identified by App server, Densité frame and slot number, card type and firmware version.

The *Profile* column shows the same information as is shown for the current card in the *Copy profile from* line, i.e. one of the following:

- All, Current, User1, User2, User3, User4, User5

The *Select* column includes a checkbox to identify which IPG-3901 cards you wish to copy profiles into from the current card.

- For convenience, a *Select all* checkbox is provided in the column header

Click *Copy* to copy the selected profiles from this card into the selected other IPG-3901 cards

- While the profile copy operation is in progress, the Transfer Status box on the right of the *Copy profile to* line will indicate *Working* against a yellow background

- When the profile copy operation is complete, the Transfer Status box on the right of the *Copy profile to* line will indicate *Succeeded* against a green background

Note – the source and destination cards must have the same firmware version, so any destination cards with a different firmware version that are shown in the *Copy profile to* list cannot be selected, and their transfer status is always N/A on a yellow background

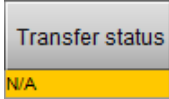

5.8 Alarm Config Panel

This panel allows the alarm reporting of the IPG-3901 to be configured. The panel opens in a new window when the button is clicked, and can be resized if needed.

The panel is organized in columns.

Status/Name

This contains an expandable tree listing all the alarms reported by this IPG-3901 card.

- Each alarm name includes an icon that shows its current status
- Some alarms may be text-only and the alarm status is shown in the name and not by a status icon

The **Card LED**, **Overall Alarm** and **GSM Contribution** columns contain pulldown lists that allow the level of contribution of each individual alarm to the alarm named in the column heading to be set.

- Click on the alarm icon to see the available levels; then click on one to select it



Card LED

This column allows configuration of the contribution of selected individual alarms to the status LED located on the front card edge. The Card LED status is shown at the bottom of the alarm tree in the Status/Name column.

Overall Alarm

This column allows configuration of the contribution of each individual alarm to the Overall Alarm associated with this card. The Overall Alarm is shown in the upper left corner of the iControl panel, and also appears at the bottom of the Status/Name column.

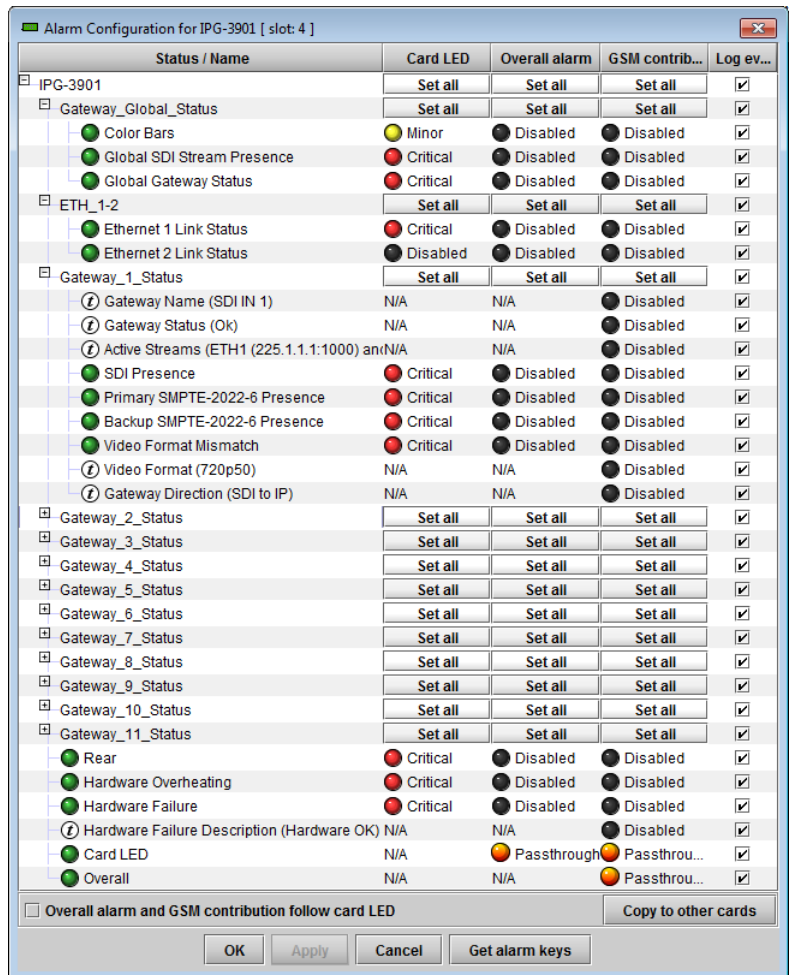

Figure 5-15 Alarm Configuration

GSM Contribution

This column allows configuration of the contribution of each individual alarm to the GSM Alarm Status associated with this card. GSM is a dynamic register of all iControl system alarms, and is also an alarm provider for external applications. The possible values for this contribution are related to the Overall alarm contribution:





- If the Overall alarm contribution is selected as Disabled, the GSM alarm contribution can be set to any available value
- If the Overall alarm contribution is selected as any level other than disabled, the GSM contribution is forced to follow the Overall Alarm.

Log Events

iControl maintains a log of alarm events associated with the card. The log is useful for troubleshooting and identifying event sequences. Click in the checkbox to enable logging of alarm events for each individual alarm.

Levels associated with these alarms:

The pulldown lists may contain some or all of the following options:

	Disabled	The alarm makes no contribution (black icon)
	Minor	The alarm is of minor importance (yellow icon)
	Major	The alarm is of major importance (orange icon)
	Critical	The alarm is of critical importance (red icon)
	Passthrough	The alarm exists but has no effect (used for text and composite alarms)

Shortcut: if you click in one of the Set All boxes beside a section heading, you will open a pulldown that lets you assign a level to all alarms in that section of the column simultaneously.

Once the alarms are configured, you may accept the changes or discard them:

Overall alarm and GSM contribution follow card LED

Click in the checkbox to force the Overall alarm and GSM contribution to be identical to the Card LED status

- All Overall alarms and GSM contributions for which there is a Card LED alarm will be forced to match the Card LED alarm
- All Overall Alarms and GSM contributions for which there is no Card LED alarm will be forced to Disabled

A warning box will open allowing you to confirm the action, since it will result in changes to the configuration and there is no *undo* function.

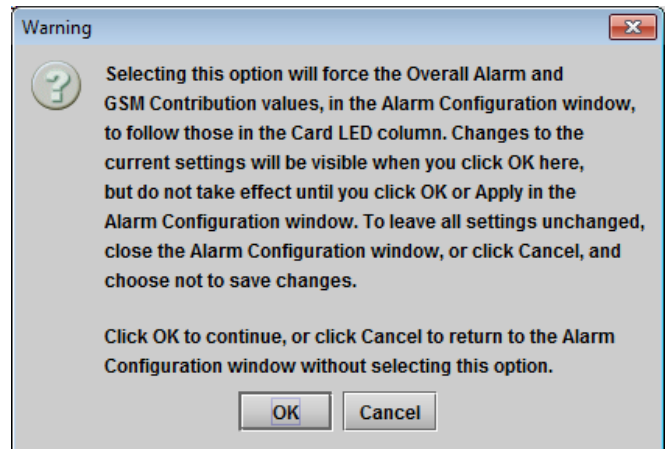

Figure 5-16 Warning for Follow LED change

Copy to other cards

Click this button to open a panel that allows the alarm configuration set for this card to be copied into another IPG-3901 card.

- Select one or more destination cards from the list in the window by clicking in the checkboxes, or all of them by clicking in the *All* checkbox
- Note that when you [copy a profile](#) for this card (see page 20), the alarm configuration is copied along with all the other settings.

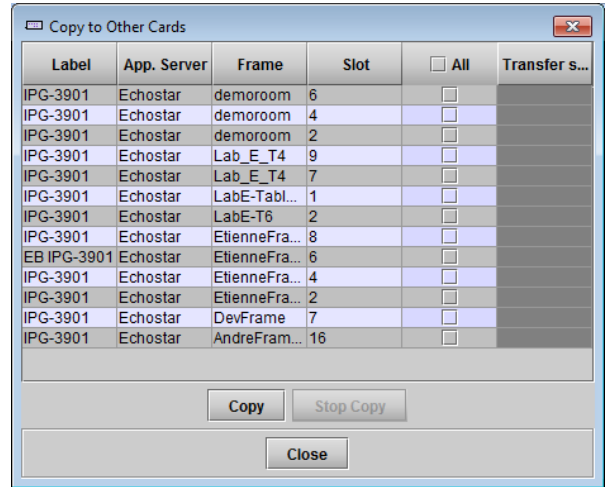

Figure 5-17 Copy to Other Cards window

Get alarm keys

Click this button to open a save dialog where you can save a file containing a list of all alarms on this card and their current values, along with an Alarm Key for each. The alarm keys are useful for system integration and troubleshooting.

- The file is saved in .csv format

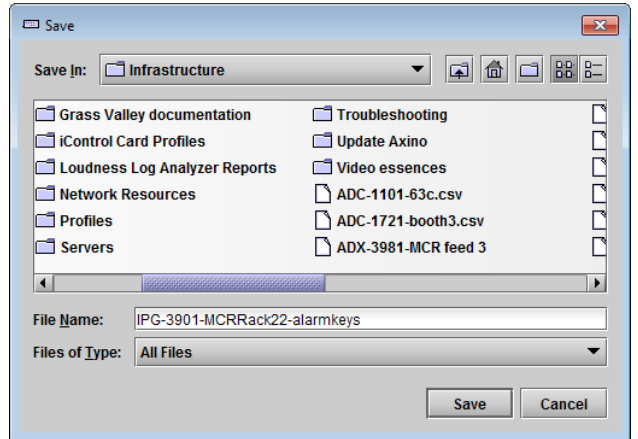

Figure 5-18 Get Alarm Keys dialog

OK, Apply, Cancel

- **OK** accepts the settings and closes the window once the card confirms that there are no errors.
- **Apply** accepts the settings, but leaves the window open
- **Cancel** closes the window without applying any changes, and leaves the previous settings intact.

5.9 Info Panel

5.9.1 Info Panel – Info tab

When the IPG-3901 is included in an iControl environment, certain information about the card should be available to the iControl system. The user can enter labels and comments that will make this card easy to identify in a complex setup. This information is entered into data boxes in the Info control panel.

Label: Type the label that is shown for this IPG-3901 when it appears in iControl applications

Short Label Type the short-form label that iControl uses in some cases (8 characters)

Source ID Type a descriptive name for this IPG-3901

Comments: Type any desired text

The remaining data boxes show manufacturing information about this card.

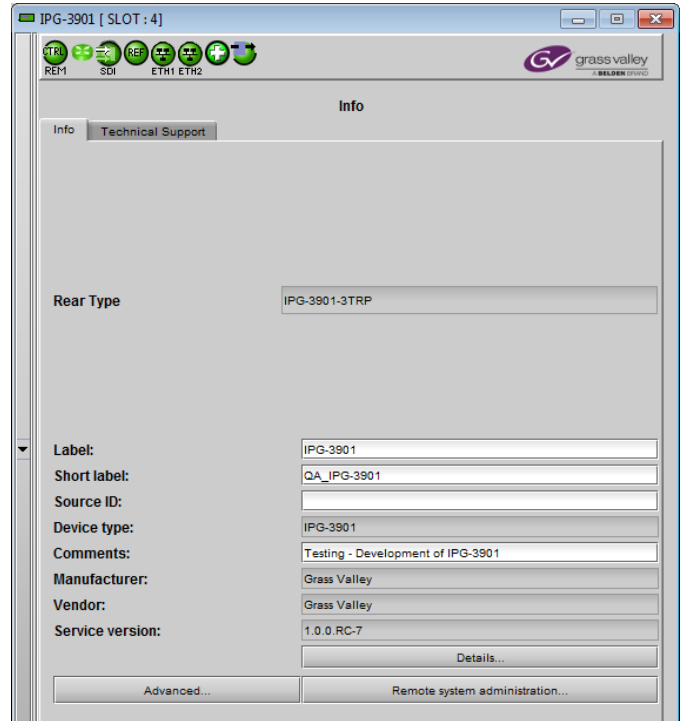

Figure 5-19 Info Panel

Three buttons in the panel give access to other information.

- **Details...:** Reports the Firmware version, service version, and panel version for this card

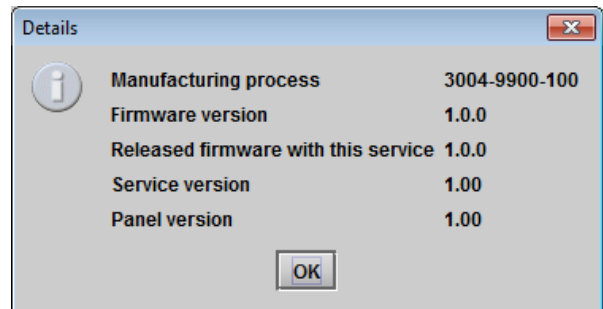

Figure 5-20 Details window

- **Advanced...:** Shows the Long ID for this card. The Long ID is the address of this IPG-3901 in the iControl network.

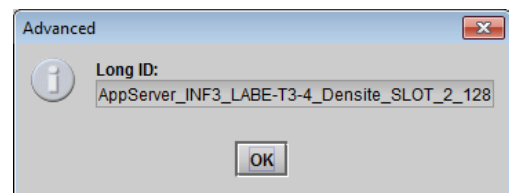

Figure 5-21 Advanced window

- Remote System Administration – opens the *Joining Locators* window, which lists remote lookup services to which this IPG-3901 is registered

Add: Force the iControl service for this IPG-3901 to register itself on a user-specified Jini lookup service, using the following syntax in the data box:

jini://<ip_address>

where <ip_address> is the ip address of the server running the lookup service, e.g.:

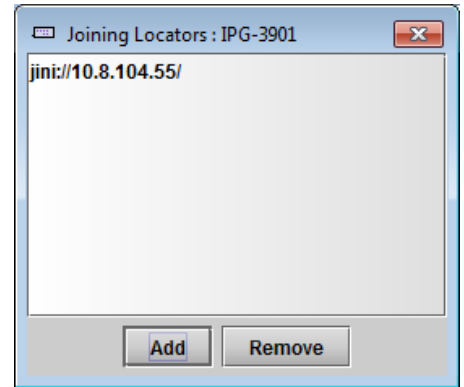
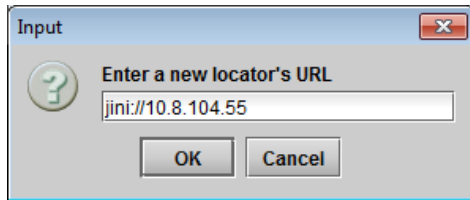
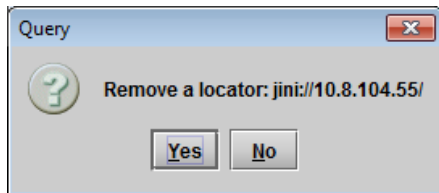

Figure 5-22 Joining Locators window

Remove: select one of the services listed in the window by clicking on it, and click *Remove* to open a query box allowing you to delete it from the window.



5.9.2 Info Panel – Technical Support tab

If technical support from Grass Valley is required for your IPG-3901, you may be requested to provide a system snapshot that will help Tech Support to troubleshoot your card.

1. Click the *Get System Snapshot* button.
2. In the Warning window that appears, click *Yes* to proceed with the snapshot, or *No* to decline.
3. If you clicked *Yes*, a system snapshot will be generated and saved on-board the card.
4. Tech Support will advise on what to do next.

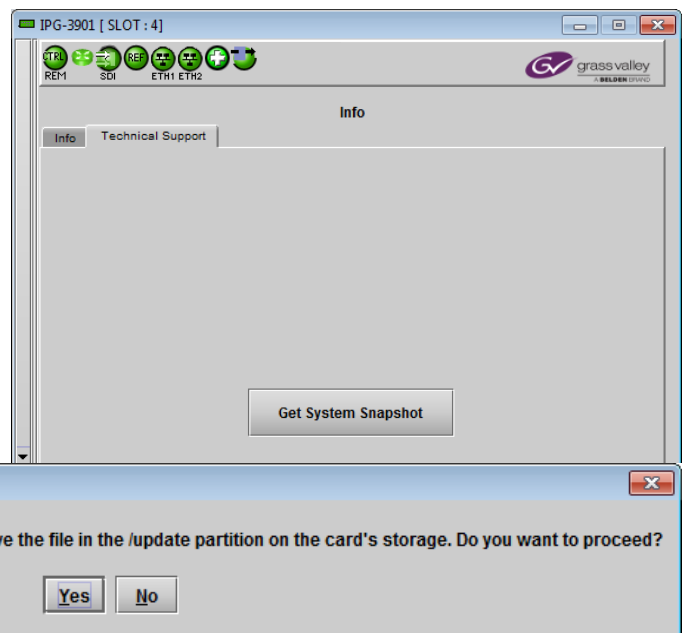

Figure 5-23 Info Panel - Technical Support tab

6 Specifications

SDI (Inputs/Outputs)

Physical: 11 BNC connectors: 2 IN, 2 OUT, 7 independently configurable as input or output

SDI Standard: SMPTE-259M-C (270 Mb/s)
SMPTE-292M (1.485, 1.485/1.001 Gb/s)
SMPTE-424M (2.970, 2.970/1.001Gb/s)*

Supported formats: SD: 480i59.94, 576i50
HD: SMPTE-274M: 1080i59.94, 1080i50
HD: SMPTE-296M: 720p59.94, 720p50
3G: SMPTE-425M level A (mapping 1), level B*: 1080p59.94, 1080p50

Cable length (Belden 1694A): SD: 300m (984 ft.) at 270 Mb/s
HD: 150m (492 ft.) at 1.5 Gb/s
3G: 100m (393 ft.) at 2.970 Gb/s

Return loss: >15 dB up to 1.5 GHz
>10 dB up to 3 GHz

Jitter: HD/SD: <0.2 UI (alignment jitter)
3G: <0.3 UI (alignment jitter)

Reference Input

Black burst 525 (SMPTE 170M and SMPTE 318M)
Black burst 625 (ITU 624-4).

Ethernet Port

Physical: Two SFP+ sockets for copper, short reach and long reach fiber
Standard: IEEE 802.3-2008 10 GigE
Transport: SMPTE 2022-6 IP Unicast or Multicast with IGMPv3
Performance: Up to 9 Gb of streaming per direction

Electrical

Power: 37.5W maximum

* 3G level A signaling currently supported. 3G level B signaling will be supported at a later date with a firmware update

7 Contact Us

Grass Valley Technical Support

For technical assistance, contact our international support center, at 1-800-547-8949 (US and Canada) or +1 530 478 4148.

To obtain a local phone number for the support center nearest you, please consult the *Contact Us* section of Grass Valley's website (www.grassvalley.com).

An online form for e-mail contact is also available from the website.

Corporate Head Office

Grass Valley
3499 Douglas-B.-Floreani
St-Laurent, Quebec H4S 2C6
Canada

Telephone: +1 514 333 1772

Fax: +1 514 333 9828

www.grassvalley.com

ANNEX – Local Menu

1st level	2nd level	3rd level	4th level	Comments / Default Value
STATUS	GENERAL	REAR TYPE	IPG-3901-3DRP	
		SERIAL NUMBER	XXXXXX-XXXXXXXX	
	REFERENCE	MISSING		
		REF NTSC		
		REF PAL		
		REF URS 29		
		REF URS 25		
	NO REF			
	REF-MISMATCH			
	UNSUPPORTED			
	NOT LOCKED			
	ETH1	LINK STATUS	LINK UP LINK DOWN	
		MAC ADDRESS	00:00:00:00:00:00	
ETH2	LINK STATUS	LINK UP LINK DOWN		
	MAC ADDRESS	00:00:00:00:00:00		
GATEWAY	[n]	ACTIVE INACTIVE DISABLED	Gives the global status for the gateway [n]. Where [n] is: SDI IN 1, SDI IN 2, SDI IN/OUT 1 to 7, SDI OUT 1 and SDI OUT 2.	
		<video format>	Reports the video format of the gateway.	
HEALTH	HARDWARE	HARDWARE OK HARDWARE FAILURE		
	FAN	FAN OK FAN FAILURE		
	TEMPERATURE	TEMPERATURE OK TEMPERATURE FAILURE		
CARD PRESET	LOAD	<name>	Loads the user preset selected.	

				<name> is the preset name
	SAVE	<name>		Save the user preset in the preset selected.
NETWORK CONFIG	ETH1	IP ADDRESS	0.0.0.0	0.0.0.0
		MASK	255.255.255.0	255.255.255.0
		GATEWAY	0.0.0.0	0.0.0.0
	ETH2	IP ADDRESS	0.0.0.0	0.0.0.0
		MASK	255.255.255.0	255.255.255.0
		GATEWAY	0.0.0.0	0.0.0.0
REFERENCE	SCAN RATE	50 / 25Hz 59.94 / 29.97Hz		59.94 Hz
	SOURCE	AUTO EXTERNAL URS NO REF		AUTO
	URS	OFF ON		OFF
TEST PATTERN	FORMAT	1080i 720p SD		1080i
	FORCE ALL	ON OFF		OFF
	[n]	ON OFF		OFF Where [n] is: SDI IN 1, SDI IN 2, SDI IN/OUT 1 to 7, SDI OUT 1, SDI OUT 2.
VERSION	vx.x.x bld xxxx			e.g.: v1.1.0 bld 134
	FPGA BUILD: xxx			Version of the FPGA
FACTORY DEFAULT	WITHOUT	APPLY		If selected, everything but network

GUIDE TO INSTALLATION AND OPERATION

	NETWORK			configuration is restored to factory
	INCLUDE NETWORK	APPLY		If selected, everything is factory defaulted.