



grass valley

A **BELDEN** BRAND

IRD-3811

HD/SD MPEG Receiver/Decoder with ASI and RF Inputs

Guide to Installation and Operation

M837-8800-105

2017-02-13

www.grassvalley.com

Copyright and Trademark Notice

Copyright © 2010-2017, Grass Valley Canada. All rights reserved.

Belden, Belden Sending All The Right Signals, and the Belden logo are trademarks or registered trademarks of Belden Inc. or its affiliated companies in the United States and other jurisdictions. Grass Valley, IRD-3811, iControl, and Densité are trademarks or registered trademarks of Grass Valley Canada. Belden Inc., Grass Valley USA, LLC, and other parties may also have trademark rights in other terms used herein.

Terms and Conditions

Please read the following terms and conditions carefully. By using IRD-3811 documentation, you agree to the following terms and conditions.

Grass Valley hereby grants permission and license to owners of IRD-3811 to use their product manuals for their own internal business use. Manuals for Grass Valley products may not be reproduced or transmitted in any form or by any means, electronic or mechanical, including photocopying and recording, for any purpose unless specifically authorized in writing by Grass Valley.

A Grass Valley manual may have been revised to reflect changes made to the product during its manufacturing life. Thus, different versions of a manual may exist for any given product. Care should be taken to ensure that one obtains the proper manual version for a specific product serial number.

Information in this document is subject to change without notice and does not represent a commitment on the part of Grass Valley.

Warranty information is available in the Support section of the Grass Valley Web site (www.grassvalley.com).

Electromagnetic Compatibility



This equipment has been tested for verification of compliance with FCC Part 15, Subpart B requirements for Class A digital devices.

NOTE: This equipment has been tested and found to comply with the limits for a Class A digital device, pursuant to part 15 of the FCC Rules. These limits are designed to provide reasonable protection against harmful interference when the equipment is operated in a commercial environment. This equipment generates, uses, and can radiate radio frequency energy and, if not installed and used in accordance with the instruction manual, may cause harmful interference to radio communications. Operation of this equipment in a residential area is likely to cause harmful interference in which case the user will be required to correct the interference at his own expense.



This equipment has been tested and found to comply with the requirements of the EMC directive 2004/108/CE:

- EN 55022 Class A radiated and conducted emissions
- ENV 50204 Radiated EMF Immunity – RF 900 MHz Pulsed
- EN 61000-3-2 Harmonic current emission limits
- EN 61000-3-3 Voltage fluctuations and flicker limitations
- EN 61000-4-2 Electrostatic discharge immunity
- EN 61000-4-3 Radiated electromagnetic field immunity – radio frequencies
- EN 61000-4-4 Electrical fast transient immunity
- EN 61000-4-5 Surge transient immunity
- EN 61000-4-6 Conducted disturbances immunity
- EN 61000-4-11 Voltage-dips, short-interruption and voltage variation immunity

Table of Contents

1	IRD-3811 HD/SD MPEG Decoder with ASI and RF inputs	1
1.1	Using this Manual	1
1.2	Introduction	1
1.3	Features.....	1
1.4	Applications	3
1.5	Block Diagrams	4
1.6	Front Card-edge Interface	5
1.7	Physical Layout – IRD-3811 with Tuner and CAM modules	5
2	Installation.....	6
2.1	Installation in the Densité frame	6
2.2	Rear Panel.....	6
2.3	Connections.....	6
2.4	Installation of the Conditional Access Module (CAM)	7
3	Operation.....	8
3.1	Control options	8
3.2	Card-Edge Status LED	8
3.3	Local control using the Densité frame control panel	9
3.4	Remote control using iControl	10
3.4.1	The iControl graphic interface window	10
3.4.2	The <i>Input</i> panel.....	14
3.4.3	Tuner panels.....	15
3.4.4	The <i>Conditional Access</i> panel	17
3.4.5	The <i>ASI Output</i> panel	18
3.4.6	The <i>Decoder</i> panel	19
3.4.7	The <i>Video Output</i> panel.....	19
3.4.8	The <i>Video Processing</i> panel	22
3.4.9	The <i>Audio Config</i> panel	23
3.4.10	The <i>Audio Processing</i> panel	24
3.4.11	The <i>Reference</i> panel	25
3.4.12	The <i>Probing</i> panel	26
3.4.13	The <i>Test</i> panel.....	28
3.4.14	The <i>Video / Audio Proxy</i> panel	29
3.4.15	The <i>Network Settings</i> panel	30
3.4.16	The <i>Factory/Presets</i> panel	32
3.4.17	The <i>Options</i> panel	35
3.4.18	The <i>Alarm Config</i> panel.....	37
3.4.19	The <i>Info</i> panel.....	40
4	User Reference Guide	43
4.1	Decoding MPEG Transport Streams.....	43
4.2	Decoding Audio	43
4.3	MPEG AV Synchronization.....	44
4.4	About V-CHIP & Rating Information	44

4.5	Using the Up/Down/Cross Option	45
4.6	About AFD processing	45
4.7	Using the TS Probing Option	49
4.8	Using the video proxy streaming.....	49
5	Specifications.....	50
6	Contact Us.....	52
	Grass Valley Technical Support.....	52
	Corporate Head Office	52
	ANNEX 1 – Local Control Panel User Interface	53
	ANNEX 2 – Dolby Metadata Profiles	57

1 IRD-3811 HD/SD MPEG Decoder with ASI and RF inputs

1.1 Using this Manual

The IRD-3811 comes in three versions:

IRD-3811-VQ	ATSC Tuner
IRD-3811-DVB-S2	DVB-S2 Tuner
IRD-3811-DVB-S2-CI	DVB-S2 Tuner with Conditional Access Module

All three are described in this manual. For convenience, any description that applies to all three variants will use the term IRD-3811. Descriptions that apply exclusively to specific versions will use the more detailed version name as given above.

THIS MANUAL DESCRIBES FEATURES ASSOCIATED WITH IRD-3811 FIRMWARE VERSION 4.00 and up.

1.2 Introduction

The IRD-3811 combines RF demodulation and MPEG-2 decoding of ASI transport streams to either HD or SD. It also offers processing of key video and audio parameters, and signal probing functions for feed aggregation, distribution, and monitoring applications by broadcasters and TV service providers.

DVB-ASI, ATSC off-air or DVBS/S2 satellite signals fed to the IRD-3811 can be demodulated and decoded to provide either HD or SD video with embedded multi-channel audio, in all leading formats. The IRD is also available with a DVB-CI slot, supporting leading Conditional Access Systems, and allowing descrambling of multiple encrypted services. With its optional Gigabit Ethernet port, the IRD-3811 can also act as a gateway, by performing IP encapsulation of the input transport stream in either RTP or UDP mode.

The IRD also provides optional video signal processing with frame synchronization and selectable delay as well as proc-amp, up/down/cross conversion and aspect ratio conversion. The IRD can decode an extensive range of Metadata, such as EIA-708 compliant Closed captioning, Teletext, AFD and V-Chip, which can be embedded in the decoded SDI signal. Transport Stream Metadata, such as PSIP can also be analyzed.

The audio processing capabilities of the IRD-3811 are also extensive, with dual audio decoding and selectable stereo downmix modes of decoded MPEG-1 and Dolby Digital (AC-3) 2.0 audio. Optionally, the IRD-3811 also performs embedding of decoded of Dolby Digital (AC-3) 5.1 audio, with discrete 8-channel output.

In addition, the IRD-3811 performs a wide range of signal quality probing, with user-defined alarm settings on an extensive range of transport stream parameters, including TR 101290 alarms, transport stream structure analysis and individual program statistics. The IRD also generates low-resolution H.264 video proxy and 2-channel audio streams of selected programs for monitoring.

1.3 Features

Input/Output Versatility

- Single ATSC 8VSB or DVB-S/S2 RF input
- Single ASI transport stream input
- Single ASI transport stream output for signal monitoring or retransmission
- Optional IP transport stream output: an ASI signal can be re-transmitted as IP
- IRD acts as IP video gateway with forward error correction (FEC) for improved quality
- Dual HD/SD SDI outputs

Conditional Access

- DVB-CI common interface slot allows insertion of CAM card
- Allows descrambling of multiple programs encrypted by leading DVB Conditional Access Systems
- Supports BISS-1 with user-supplied CAM card.

RF Input Monitoring

- Automatic detection of RF loss
- Convenient auto-scan mode for detection of valid signals
- Monitoring of input signal strength, bit error rate (BER) and carrier to noise ratio (CNR)

Easy Input and Program Selection

- Manual or automatic input selection mode
- Automatic mode allows switching to backup input upon loss of signal on active input, with adjustable duration
- Program selection using local control or iControl
- Extensive transport stream structure is displayed allowing easy identification of individual programs in an MPTS
- MPTS automatic program selection mode and recovery

Extensive Video Decoding

- The IRD-3811 can decode signals in various resolutions extending to 1920x1080i, and at various frequencies. Output formats include:
 - 1920x1080i 59.94
 - 1920x1080i 50
 - 1280x720p 59.94
 - 1280x720p 50
 - 720x486i 59.94
 - 720x576i 50

Comprehensive Audio Decoding

- Decoding of MPEG-1 Layer 2 stereo audio
- Support of Dolby Digital (AC-3) 2.0 audio
- Optional decoding and embedding of Dolby Digital (AC-3) 5.1 audio to SDI with support of main and associated audio services for up to discrete 8-channel output
- Selectable passthrough of Dolby Digital stream to SDI
- Decoding of AAC Audio for 2/0 and 1/0 coding modes

Frame Synchronizer/Delay and Reference Input

- Supports timing, full phasing and freeze modes
- Reference can be external via BNC connection, internal using Densité REF-1801 module or directly from the decoded signal with selectable genlock modes
- Video proc amp functions including, brightness, saturation, hue and contrast

Decoded Video Format Identification

- Convenient identification of key video parameters
 - Aspect ratio identification: 16:9 or 4:3
 - Video resolution

Video Up/Down/Cross Conversion

- Extensive selection of video format conversions

Audio Processing and Format Identification

- Provides down mix of 5.1 channel to Lt/Rt or Lo/Ro modes
- Extensive Dolby Digital Status reporting, including:
 - Service and Source Channel ID
 - Low Frequency Effect (LFE) presence detection
 - Sample rate detection
 - Bit rate reporting
- Support for Secondary Audio Program (SAP)
- Configurable Dolby Digital dynamic range and compression
- Dolby Metadata embedding on SDI

Metadata Extraction, Display and Embedding

- The following can be extracted from the TS and embedded in SD-SDI or HD-SDI signal:
 - EIA-608 and EIA-708 closed captioning
 - WST teletext
- SMPTE 2016 AFD flag
- Extensive PSIP data extraction, including:
 - Time and date and other STT data
 - Channel number and other VCT parameters
 - Event description and EIT Event Information Table
 - Rating and other RRT data
 - Dolby metadata
 - TSID

Transport Stream Probing and Alarming

- Transport Stream (TS) monitoring, alarming and settings:
 - TR 101 290 Priority 1 and Priority 2 alarming on key parameters
 - TS Bit rate
 - TS ID and number of programs as identified in PAT
 - Network ID and name as identified in NIT
 - Logging of alarms using iControl
- Detailed TS structure reporting using graphical and hierarchical views
- Individual program data statistics, including individual program bit rate, content and PMT data
- IRD generates low-resolution H.264 video proxy and 2-channel audio streams of selected programs for monitoring

1.4 Applications

- Decoding of MPEG-2 multi-program or single-program ASI transport streams
- IP encapsulation of ASI transport streams
- Program aggregation in TV service-provider headends

1.5 Block Diagrams

The following block diagrams show the functionality of the IRD-3811.

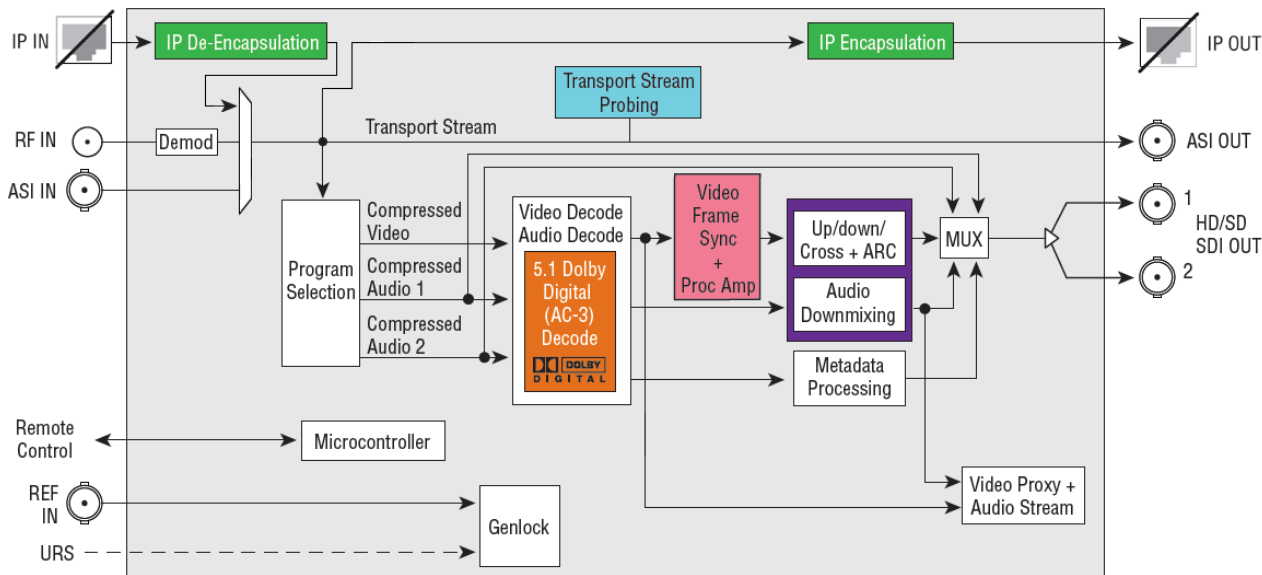

IRD-3811-VQ & IRD-3811-DVB-S2 Functional Block Diagram

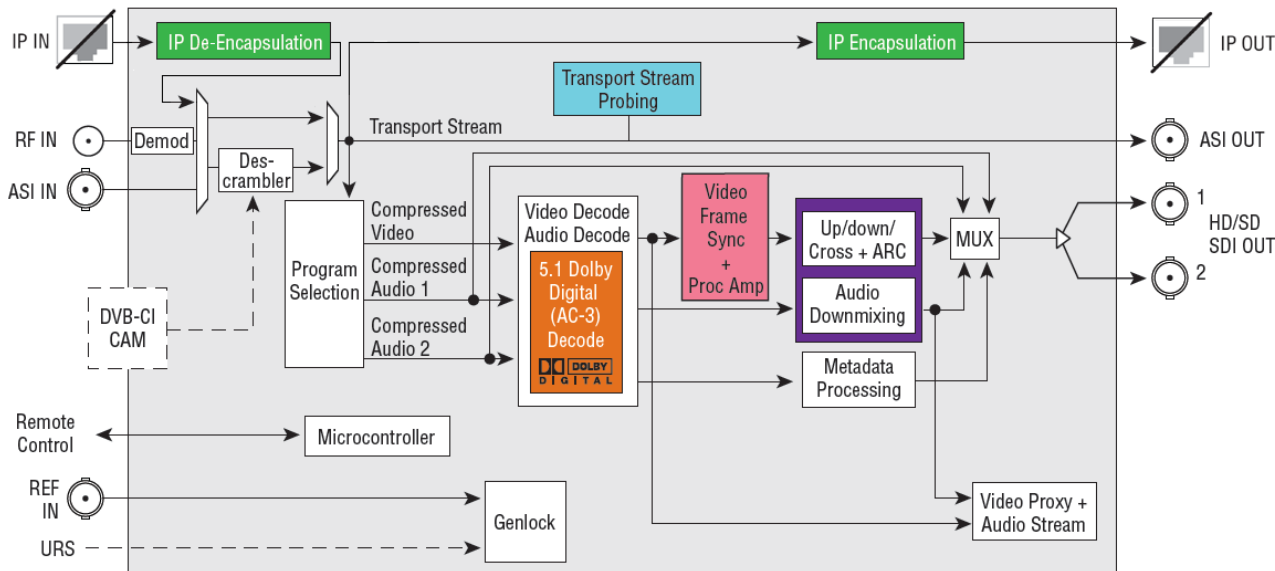

IRD-3811-VQ-CI & IRD-3811-DVB-S2-CI Functional Block Diagram





Options			
	IRD-38NN-OPT-FS: Frame Synchronization and Delay Option with Reference, Genlock, and Advanced Audio Proc		IRD-38NN-OPT-ETH: Ethernet Input/Output Option for IRD-3811
	IRD-38NN-OPT-DOLBY: Dolby Digital (AC-3) 5.1 Audio Decoder Option		IRD-38NN-OPT-TS-PROBE: Transport Stream Probing Option
			IRD-38NN-OPT-UDC: Up/Down/Cross Converter Option

Figure 1.1 Functional block diagram of the IRD-3811

1.6 Front Card-edge Interface

The front card-edge of the IRD-3811 incorporates two elements:

- Status LED (see section 3.2)
- Select Button (see section 3.3)

The CAM module and tuner are not shown in this view.

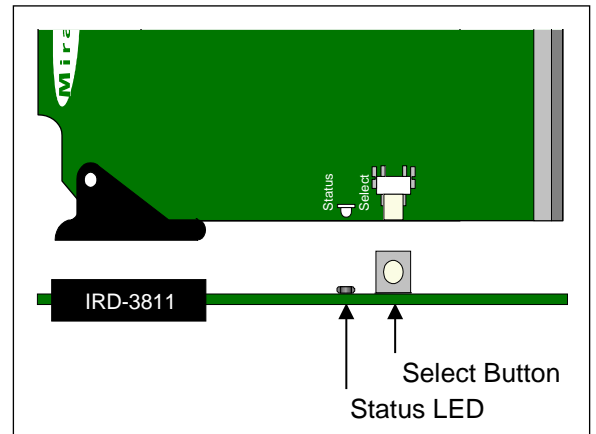

Figure 1.2 Front card-edge layout

1.7 Physical Layout – IRD-3811 with Tuner and CAM modules

The IRD-3811 consists of a base IRD-3811 card with a tuner module (either ATSC or DVB-S2) and, optionally, a conditional access module (CAM).

- The tuner is installed at the rear of the card, with its RF input available on the rear panel of the Densité frame.
- The CAM is installed at the front of the card, so that the smart card can be inserted from the front of the Densité frame.

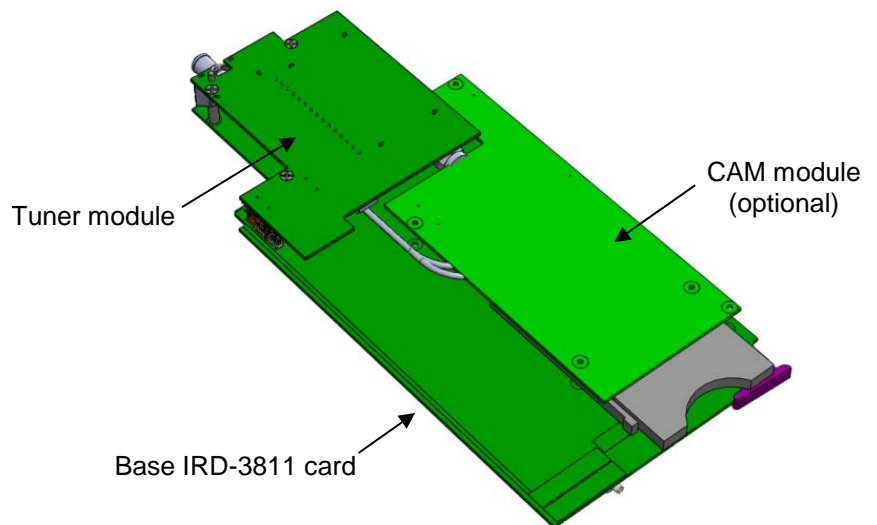

Figure 1.3 IRD-3811 physical layout

2 Installation

2.1 Installation in the Densité frame

The IRD-3811 and its associated rear connector panel must be mounted in a Densité 3-series frame (Densité 3, Densité 3+FRx, GV Node). It is not necessary to switch off the frame’s power when installing or removing the card. See the appropriate Densité 3 Frame manual for detailed instructions for installing cards and their associated rear panels.

2.2 Rear Panel

The IRD-3811 has multiple inputs and outputs, and making space for all the necessary connectors at the rear of the frame requires a double-width rear panel.

With the double-width rear panel installed, the IRD-3811 must be installed in the **right-most of the two slots** covered by the panel in order to mate with the panel’s connectors.

NOTE: attempting to install the card in the wrong slot could result in damage to the edge connector of the rear panel. BE CAREFUL

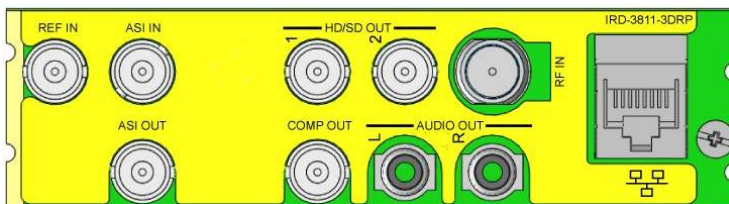

Figure 2.1 IRD-3811-3DRP Rear Panel for the IRD-3811

2.3 Connections

The rear panel connections are as follows:

- **REF IN** – External reference input

For external synchronization, connect a black studio reference signal to the BNC labeled **REF IN**.

The reference input must conform to SMPTE 170M/SMPTE 318M/ITU 624-4/BUT 470-6 for standard definition signals and SMPTE 274M / SMPTE 296M for high definition signals and is used to phase the HD/SD SDI outputs to the studio.

The table shows the reference signals appropriate for the supported input formats. In essence, the input and the reference must have the same frame rate.

- A reference mismatch will occur if there is a difference between the input video format’s frame rate and the reference format’s frame rate.
- When a mismatch occurs, an input error will be flagged and the card-edge Status LED will turn red to indicate the mismatch.

Supported input signals	Reference
525 (SMPTE-259M-C)	NTSC (SMPTE-170M)
625 (SMPTE-259M-C)	PAL (ITU 624-4)
1080i50 (SMPTE-274M)	1080i50, PAL
1080i59.94 (SMPTE-274M)	1080i59.94, NTSC
720p50 (SMPTE-296M)	720p50, PAL
720p59.94 (SMPTE-296M)	720p59.94, NTSC
ASI (EN50083-9)	-----

- **ASI IN** – Connect a DVB-ASI signal conforming to EN 50083-9.
- **ASI OUT** – Outputs the selected input, tuner or DVB-CI
- **HD/SD OUT 1 & 2** – SDI output, HD or SD

The IRD-3811 provides two identical HD/SD SDI video outputs on BNC connectors. The SDI video signals conform to the SMPTE 292M and SMPTE 259M-C standards. The output format follows the input format.

- **COMP OUT** –Not used
- **AUDIO OUT (L & R)** – Not used
- **ETH** – Gigabit Ethernet – configurable as input or output
- **RF IN** – connect an RF input appropriate for the installed tuner:
 - ATSC if the ATSC tuner is installed
 - DVB-S/S2 RF if the DVB-S2 tuner is installed

2.4 Installation of the Conditional Access Module (CAM)

The Conditional Access Module (CAM) is installed into the IRD-3811 via the front panel.

Depending on the conditional access system in use, the CAM may be in the form of a proprietary module, or in the form of a carrier plus a smart card.

Both formats plug into the same receptacle on the IRD-3811.

3 Operation

3.1 Control options

The IRD-3811 can be controlled in two different ways:

- The local control panel and its push-buttons can be used to move through a menu of parameters and to adjust parameter values (see section 3.3).
- Grass Valley's iControl system can be used to access the card's operating parameters from a remote computer, using a convenient graphical user interface (GUI). (see section 3.4)

3.2 Card-Edge Status LED

The status monitor LED is located on the front card-edge of the IRD-3811, and is visible through the front access door of the DENSITÉ frame. The chart shows how the various error conditions that can be flagged on the IRD-3811 affect the LED status.

- If a cell in the chart is gray, the error condition cannot cause the LED to assume that status
- If more than one LED status is possible for a particular error condition, the status is configurable. See Section 3.4.18 for details.
- The factory default status is shown by a ⚙, and forced status by an X

The LED will always show the most severe detected error status that it is configured to display, and in the chart error severity increases from left to right, with green representing no error/disabled, and flashing red the most severe error.

Alarm Name/Error Report	Led Color				Description
	Green	Yellow	Red	Flashing Red	
Card booting		X			After power-up, the led becomes yellow until Linux is properly booted (takes about 40s)
Hardware/System Failure				X	Major hardware or system failure. In some cases, the error log will show the reason
No Rear Detect				X	As per densité
No TS Input Signal			⚙		No MPEG TS input detected
TS Limit		⚙			TS has more than 128 PIDs or more than 64 programs or more than 1024 tables
No Video Signal			⚙		The MPEG TS input might be present, but no video signal is available for decode
No Audio Signal		⚙			The video may be present, but no audio stream is valid for decode
No Reference Signal			⚙		No reference signal is detected
Reference Mismatch		⚙			A reference mismatch is detected
Program not synchronized	⚙				The decoded video is not synced on PCRs
Test Bars ON		X			The card is in test mode with color bar activated

If the LED is Flashing Yellow, it means that the card is selected for local control using the Densité frame's control panel. See Section 3.3 for details.

3.3 Local control using the Densité frame control panel

There are two types of local control panel:

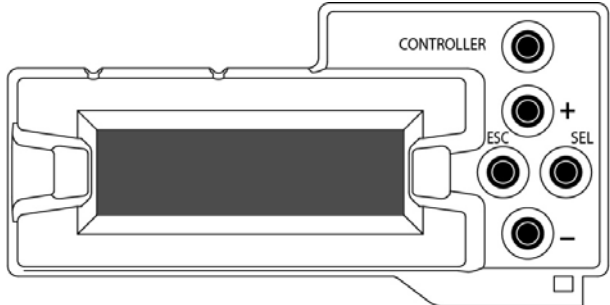
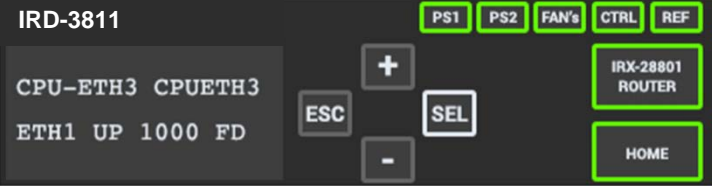
Panel type	Frame models	Appearance
Physical	Densité-2, Densité-3, Densité-3+FR1,	
Touch screen	Densité 3+FR4, GV Node	

The local control panel is fastened to the front of the controller card.

- The physical panel is accessed by opening the front door of the frame.
- The touch screen panel is accessed through an aperture in the frame door.

The panel consists of a display capable of displaying two lines of text, each 16 characters in length, and four pushbuttons. The functionality of the pushbuttons is as follows:

[+] [-] Used for menu navigation and value modification

[SEL] Gives access to the next menu level. When a parameter value is shown, pushing this button once enables modification of the value using the [+] and [-] buttons; a second push confirms the new value

[ESC] Cancels the effect of parameter value changes that have not been confirmed; pushing [ESC] causes the parameter to revert to its former value.

Pushing [ESC] moves the user back up to the previous menu level. At the main menu, [ESC] does *not* exit the menu system. To exit, re-push the [SEL] button for the card being controlled.

If no controls are operated for 30 seconds, the controller reverts to its normal standby status, and the selected card's STATUS reverts to its normal operating mode.

To assign the local control panel to the IRD-3811:

- Physical Panel: Push the SELECT button on the IRD-3802 card edge (see Section 1.4).
- Touch-screen panel: In the home screen, touch the virtual button corresponding to this IRD-3811.

The STATUS LED on the IRD-3811 flashes yellow, and the touch-screen status shows yellow for the IRD-3811.

Use the control panel buttons to navigate through the menu, as described above. The complete menu structure is shown in [ANNEX 1 – Local Control Panel User Interface](#) beginning on page 53.

3.4 Remote control using iControl

The operation of the IRD-3811 may be controlled using Grass Valley's iControl system.

- This manual describes the control panels associated with the IRD-3811 and their use.
- Please consult the iControl User's Guide for information about setting up and operating iControl.

In iControl Navigator or iControl Websites, double-click on the IRD-3811 icon to open the control panel.

3.4.1 The iControl graphic interface window

The basic window structure for the IRD-3811 is shown in figure 3.2. The window identification line across the top gives the card type (IRD-3811) and the slot number where the card installed in its Densité frame.

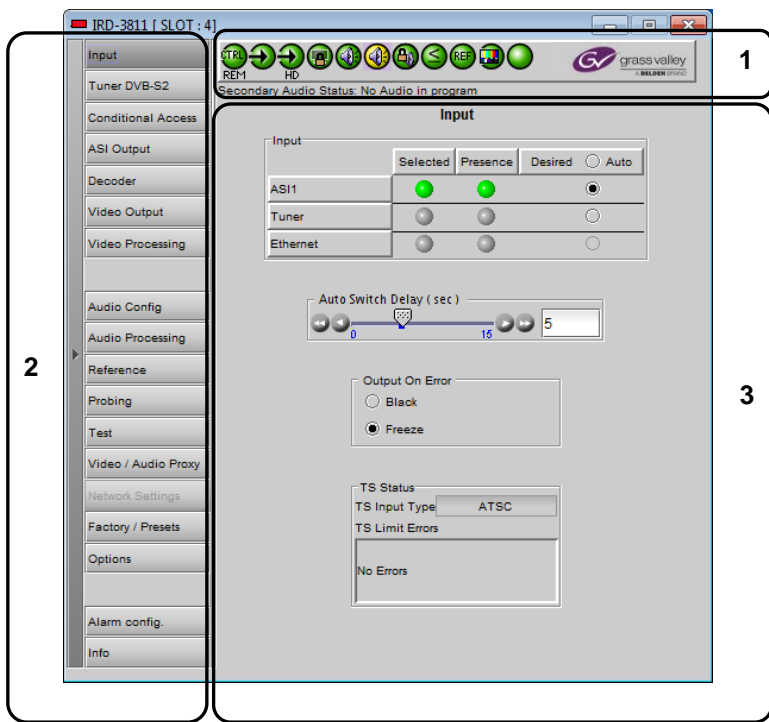



























Figure 3.2 IRD-3811 iControl graphic interface window





There are three main sections in the window, identified in figure 3.2:

Section 1. The Status Icon area shows a series of eleven icons that report the status of some card parameters. The table shows the various forms that may appear (icons are numbered left to right):

Icon #1 – Manual Card Configuration	
	Remote card control activated. The iControl interface can be used to operate the card
	Local card control active, The card is being controlled using the Densité frame control panel, as described in section 3.3. Any changes made using the iControl interface will have no effect on the card.

Icon #2 – TS Input status	
 (green)	Transport Stream detected and OK.
 (yellow)	Errors in TS No lock
 (red)	No Transport Stream at stream demux No rear
Icon #3 – Decoded Video status	
 (green)	Signal detected and valid <ul style="list-style-type: none"> The format (HD or SD) will be indicated beneath the icon
 (red)	No signal No rear Reference mismatch Format mismatch with output format (Key/Fill mode) Video/TRS error
 (gray)	No transport stream
Icon #4 – Video Sync Status	
 (green)	OK; Locked on incoming PCR
 (yellow)	Free run
 (gray)	No signal
Icon #5 – Primary Audio status	
 (green)	OK.
 (yellow)	No audio in program

 (gray)	No signal
Icon #6 – Secondary Audio status	
 (green)	OK
 (yellow)	No audio in program
 (gray)	No signal
Icon #7 – Audio Sync	
 (green)	Locked with Video
 (yellow)	Free run
 (gray)	N/A
Icon #8 – TS Limit	
 (green)	No errors
 (red)	Errors detected
 (gray)	No transport stream
Icon #9 – Reference	
 (green)	Locked to external reference <ul style="list-style-type: none"> • Mouse-over the icon to see a description of the reference in use
 (red)	Reference missing

 (gray)	Frame sync option disabled
Icon #10 – Color Bars	
 (green)	Color bars OFF
 (yellow)	Color bars ON
Icon #11 – Metadata Insertion	
 (green)	No AFD / Dolby / Timecode / Teletext insertion conflicts
 (yellow)	AFD / Dolby / Timecode / Teletext insertion conflicts

Move the mouse over an icon and a status message appears below the icon providing additional information. If there is an error, the error status message appears in the message area without mouse-over.

- If there are multiple errors, the error messages cycle so all can be seen
- The icon whose status or error message is shown is highlighted with a mauve background

Section 2. The left-hand side of the panel contains a series of buttons that control the contents of the main window (section 3). Click on one to access the indicated controls. The selected button is highlighted (darker) and the main panel heading matches the button name.

- Some of the buttons will be different depending on which model of the IRD-3811 is in use
- This section can be hidden or revealed by clicking the arrow icon at the center of the left side border.

Section 3. This section contains the main operating controls and displays for managing the IRD-3811's feature set. The contents are selected by clicking a button in section 2 on the left-hand side of the screen.

Each of the panels associated with the groups accessed from the buttons in section 2, and shown in section 3, is described individually in the following sections.

3.4.2 The *Input* panel

This panel provides resources for input configuration and monitoring

Input section

Use the *Desired* radio buttons to select the input. Available options are:

- ASI1 – ASI input
- Tuner – The built-in ATSC or DVB-S/S2 tuner
- Ethernet – the data stream arriving on the rear-panel Ethernet port (only available when it is in Input mode)
- AUTO – select the first valid input, prioritized as listed here (i.e. ASI1, Tuner, Ethernet)

The Selected and Presence icons show which input is currently selected, and which ones are currently available.

Auto Switch Delay

Use the slider, or type a value directly into the data box, to set the time the card will wait before switching automatically to another valid input if the current TS signal fails.

Output on Error

Use the radio buttons to set the behavior of this IRD-3811 in the event of an input signal error.

- Black – switch the output to black
- Freeze – freeze the output on the last valid frame

TS Input Type – this box reports the transport stream type.

TS Limit Errors – the box lists any limit errors detected in the transport stream

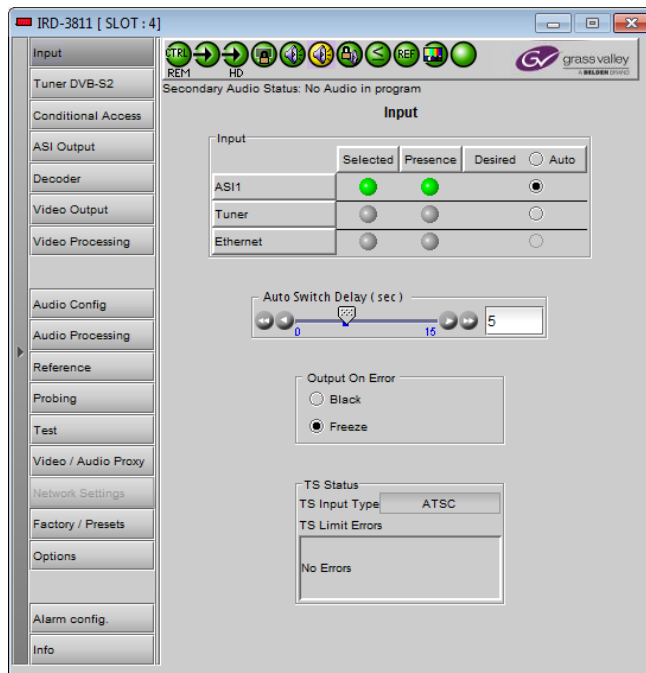

Figure 3.3 The *Input* panel

3.4.3 Tuner panels

The Tuner panel that appears will match the tuner type installed in the IRD-3811.

3.4.3.1 The *Tuner ATSC* panel (IRD-3811-VQ models only)

This panel identifies the tuner type and demodulation type, and provides status icons for RF Signal Presence and RF Signal Lock.

Incoming signal quality is measured using two parameters:

- BER (bit error rate)
- CNR (carrier-to-noise ratio)

The signal status is indicated by a color-coded bar graph.

- Green = satisfactory
- Yellow = marginal
- Red = poor

Note that this is NOT a signal level meter. An overloaded input will result in errors that reduce the quality, and the graph will show the signal status as Poor, with the bar red and on the left side of the display.

Use the *Select Channel* pulldown to select a channel from those available in the signal, or use the *Scan* button to scan through the channels to find a program stream.

The *Frequency* data box shows the frequency of the currently-selected channel.

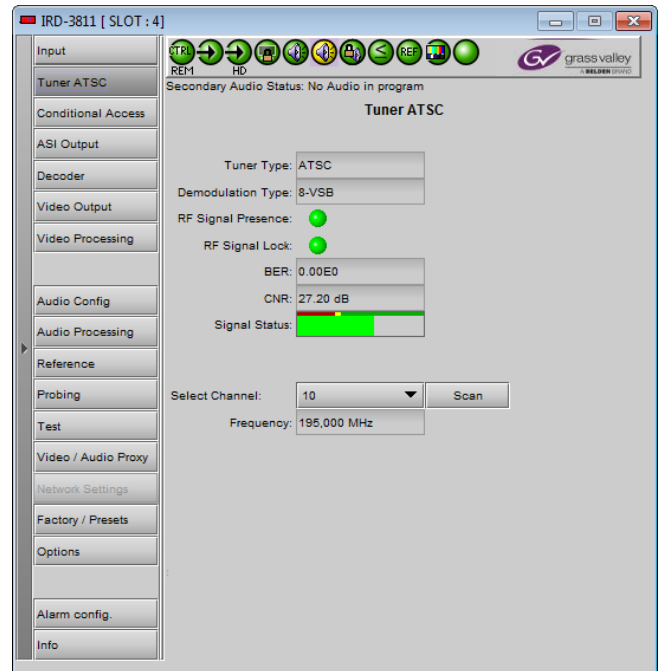

Figure 3.4 Tuner ATSC panel

3.4.3.2 The *Tuner DVB-S2* panel (IRD-3811 DVB-S2 models only)

Tuning Type

Options: DVB-S, DVB-S2

The proper FEC detection settings are dynamically assigned

BER: shows the Bit Error Rate

Demod Type: QPSK for DVB-S tuning

Selectable for DVB-S2 tuning:

Options: QPSK, 8PSK

Es/No: shows the mean symbol energy to noise ratio of the tuned signal

Signal Strength: the colored bar graph and superimposed measured value indicate the strength of the incoming signal for demodulation.

- Green: In spec
- Red: Out of spec

Frequency

Selected: Nominal frequency for the channel. This value is calculated from the carrier’s published frequency for the desired service on the satellite, and the conversion factor for the LNB (Low Noise Block) downconverter that is in use, and entered into this panel manually (NB. see section on Presets below).

Actual: This window shows the actual frequency detected by the tuner

Scan Range: Use the pulldown to select a scan range around the selected value
Options: 1 MHz, 2 MHz, 3 MHz,, 9 MHz, 10 MHz.

Symbol Rate

Selected: enter the data provided by the carrier

Actual: measured value at the IRD-3811

Code Rate / FEC

It is necessary to specify the overhead dedicated to forward error correction.

Selected: Use the pulldown to manually enter the value specified by the satellite signal provider. In the case of DVB-S, the value can be recovered from the signal, so an Auto detect mode is provided.

- In DVB-S mode: [Auto, 1/2, 2/3, 3/4., 5/6, 7/8]
- In DVB-S2 mode: [1/2, 3/5, 2/3, 3/4, 4/5, 5/6, 8/9, 9/10]

Actual: DVB-S mode only – shows the current value; useful in Auto mode.

Roll Off: spectral band shaping characteristics. Bandwidth = (1 + Roll-off factor) * symbol rate

- DVB-S mode: 0.35
- DVB-S2 mode: [0.20, 0.25, 0.35]

Spectral Inversion: If the L.O. of the LNB downconverter is higher than the satellite downlink frequency, the downconverted spectrum will be inverted, and must be re-inverted in the tuner.
[Not Inverted, Inverted, Automatic]

DVB-S2 Pilot: The pilot tone may be included in the DVB-S2 signal, and detecting it may be required for locking on to the signal. Not available in DVB-S mode. Use the radio buttons to turn pilot detection ON or OFF.

LNB Control Settings:

The Low Noise Block downconverter can output four different bands of signals extracted from the incoming satellite signal. Only one can occupy the bandwidth available on a coaxial cable, so a selection process is required. The selection mechanism employed can be used to switch the output of an LNB equipped with a single output among the four possible bands, or select among the four available outputs of a 4-output LNB to choose the input to the IRD-3811’s tuner using an outboard switching arrangement. The switching signal uses two methods:

- DC voltage applied to the tuner end of the cable (13 V or 18V) – selects the polarization
Note: the IRD-3811 may not supply enough power to operate an LNB directly – the LNB supply current is limited to 80 mA – which case the voltage from the IRD-3811 should be used to trigger an external driver that switches the LNB.
- A 22 KHz tone sent to the LNB from the IRD-3811 – selects the frequency band.

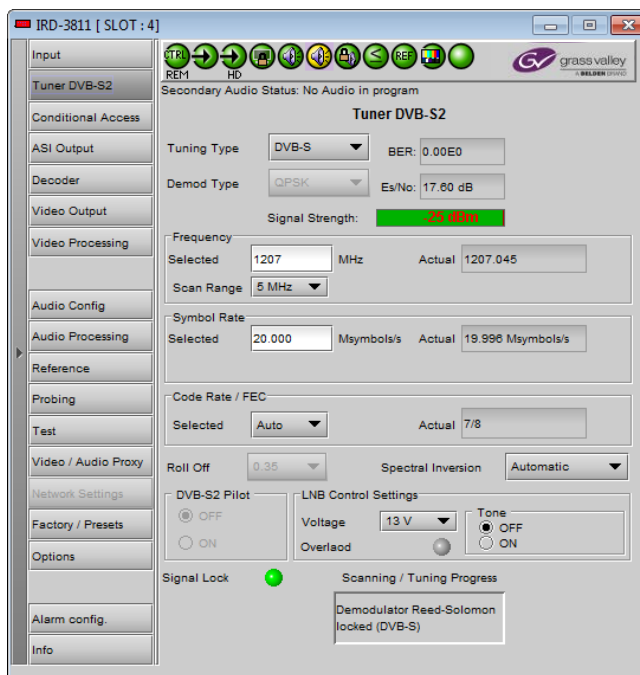

Figure 3.5 Tuner DVB-S2 panel

The chart shows what combination of signals results in the application of which input channel to the IRD-3811 inputs:

		Applied DC voltage	
		13 V	18V
Tone	OFF	9.75 MHz / vertical	9.75 MHz / horizontal
	ON	10.6 MHz / vertical	10.6 MHz / horizontal

Voltage: use the pulldown to select the voltage: [OFF, 13V, 18V]

Overload: the icon is red when overload exists.

Tone: Use the radio buttons to turn the tone ON or OFF.

Scanning / Tuning Progress

A text message may appear in the window, showing the current or most recent status of the scanning/tuning process.

The Signal Lock status icon will turn green when the tuner has locked onto the signal.

3.4.4 The Conditional Access panel

Conditional Access is only available when a DVB-S2 tuner and a conditional access module are installed. This panel and its access button will not appear for IRD-3811s with an ATSC tuner.

CAM status: The icon is green when a valid CAM card is detected in the card reader

CAM ID: CAM card identifier

Manufacturer ID: Identifies the manufacturer of the CAM card currently installed

Supported CA Systems: a list of all the encryption systems supported by the installed CAM card.

Table:

The table at the center of the panel lists all the programs in the current channel that are decodable using the installed CAM card.

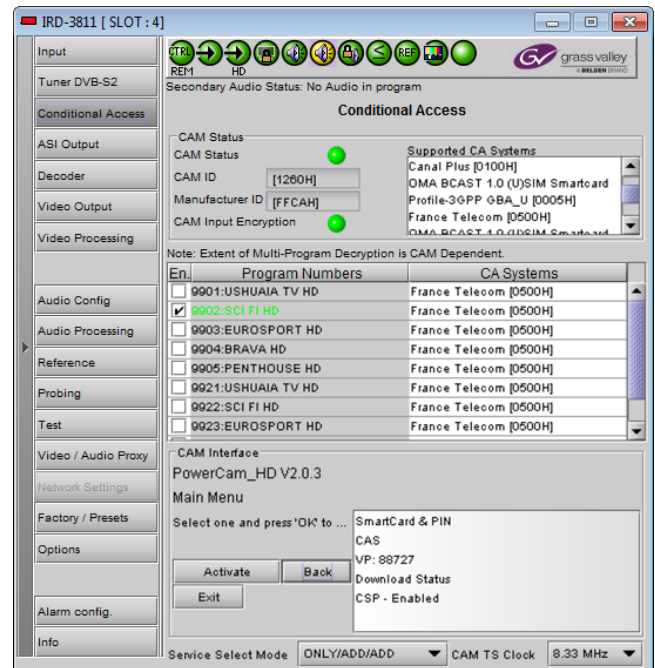

Figure 3.6 Conditional Access panel

Note that programs may or may not be decryptable by the current CAM, depending on the rights obtained with the smart card or your contract with the CA or program provider

En: Click in the box to enable decryption of the selected program.

The current video decoder selection is always selected (shown in blue)

Program Numbers: Program identification number along with some descriptive text

CA Systems: The CA system that is used with the associated program

CAM Interface:

The section of the panel allows the user to query the CAM card and set up its operation

Click *Activate* to start the process, and then follow the instructions that appear in the panel.

- *Note that this portion of the interface is provided by the CAM itself and is therefore dependant on the type of CAM used*

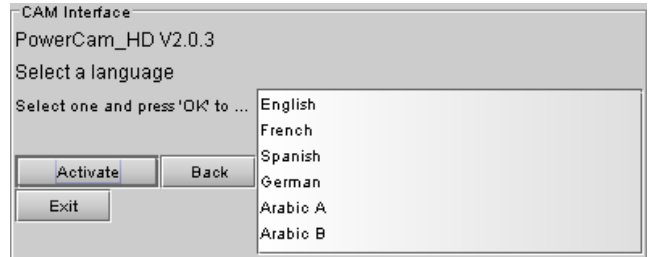

Service Select Mode:

[ONLY/ADD/ADD], [FIRST/MORE/LAST]

CAM TS Clock:

[10 MHz, 9 MHz, 8.33 MHz, 6.25 MHz, 5 MHz, 4.16 MHz]

The Common Interface standard calls for a 9 MHz maximum clock speed, and most CAMs will operate properly with an 8.33 MHz clock.

- Some older CAMs don't quite meet the Common Interface standard, and will only operate at lower clock speeds.
- Some professional CAMs, because of the higher bit rate, will require a faster clock. Remember that the maximum bit rate that can be processed by the CAM is eight times the clock frequency.

3.4.5 The ASI Output panel

This panel allows selection of the source of signal for the ASI output.

Use the pulldown to select between:

- Selected Input (on *Input* panel)
- Tuner – from the on-board tuner
- DVB-CI (only if DVB-S2 tuner and conditional access module are installed)



Figure 3.7 ASI Output panel

3.4.6 The Decoder panel

The decoder panel gives the user the resources to select the program that will be decoded by the IRD-3811

Config section:

Service Select – use the pulldown to select the service from among those in the transport stream
 A small lock icon to the left of the service number indicates that the signal is encrypted.

Audio1 & Audio 2 – Use the pulldowns to select the audio 1 and 2 PIDs from the available channels.

NOTE that you can't select the same PID for both audios

Clock Recovery – use the pulldown to configure clock recovery. Options are:

- OFF – user the local clock. Preferred if there are many errors in the stream or the IRD cannot lock easily
- From PCR - recover the clock from the PCR packet

Service Selection Mode – use the pulldown to choose how the service to be decoded is selected:

- Manual – decode the service selected in the *Service Select* pulldown. If the service is not present in the TS, nothing is decoded
- Auto – if the service selected in the *Service Select* pulldown does not exist or if none is specified, the card decodes the first service found



Figure 3.8 Decoder panel

Currently Selected Service / Video / Audio

The data windows and status icons in this area report on various aspects of the currently-selected service, video and audio

This area provides information only – no controls are available

3.4.7 The Video Output panel

Input and Output Screens

The two screens at the top of the panel indicate the aspect ratio of the input and output video. The pulldowns for Aspect and Format on the output screen allow the output signal to be formatted.

- Note: the Up/Down/Cross option must be enabled before these controls become active.

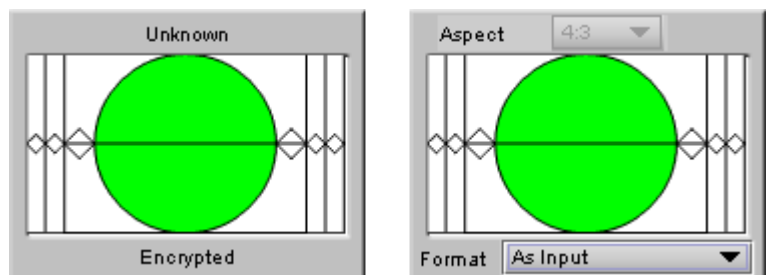

3.4.7.1 AFD tab

Mode

Use the AFD Mode pulldown to select the operating mode

- Auto
- Manual

Config

Use the *Insertion* pulldown to select whether AFD information will be inserted in the output.

- OFF
- AFD

Insertion Line: The Insertion line is used to select on which line in the VANC the AFD packet (SMPTE 2016) will be inserted. It is not necessary to specify the detection line since the card will automatically detect the incoming packet.

Default settings

The *Default* data box shows the default AFD code to be used if no valid AFD code is detected at the input (AUTO), or the AFD that is always used (MANUAL)

Change: Click the *Change...* button to open the *Select AFD* panel showing the available AFD codes that could be used as the default. Click on one to select it, then click *Apply* or *OK* at the bottom of the panel.

Flags

This section gives information about AFD flag management.

Presence – the status icon is green if AFD flags are detected in the input data stream

Detected – the data box shows the AFD code for the detected flags

Inserted – the data box shows the code of the AFD inserted in the output data stream

Aspect Ratio Scaling Mode

Use the pulldown to select the aspect ratio scaling mode that will be used. These options are available:

- OFF
- Auto
- Stretch
- Center Cut
- Letter box
- Pillar box

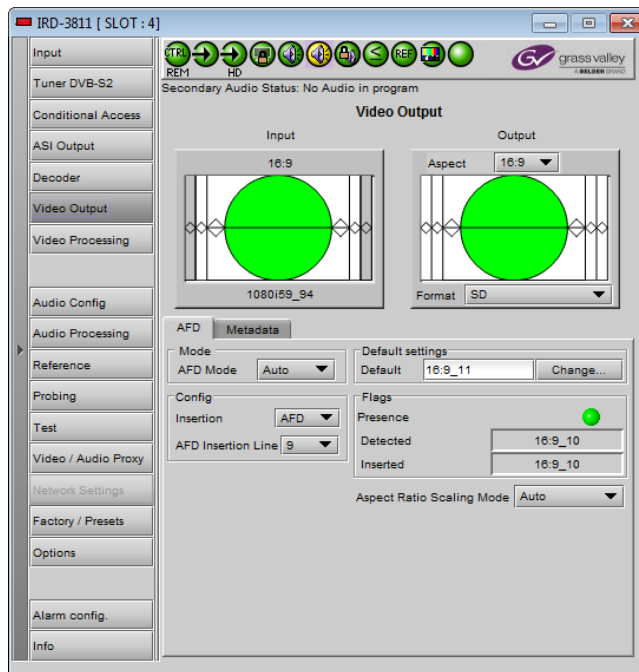

Figure 3.9 Video Output panel – AFD tab

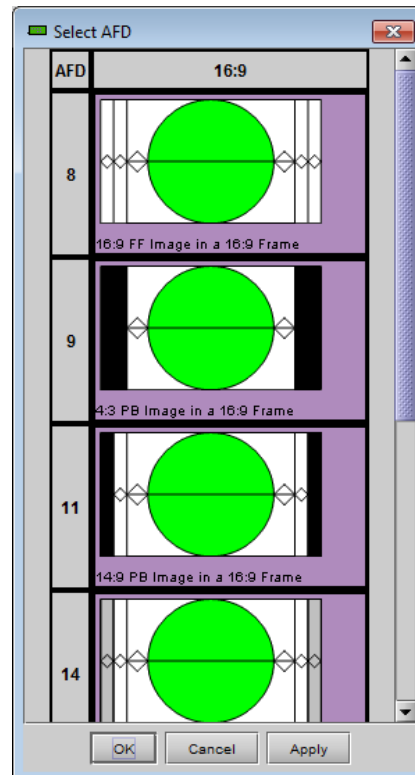

Figure 3.10 Select AFD panel

3.4.7.2 Metadata / Metadata tab

This panel indicates presence and provides control of closed caption and teletext insertion on this IRD-3811.

Closed Caption

- ON
- OFF

Note: for CVBS output, CC is always on, and not affected by this control

Teletext - Insertion – select the teletext insertion mode:

- OFF – no teletext insertion
- AUTO – teletext is inserted if detected at the input.

3.4.7.3 Metadata / Dolby tab

This tab provides resources for configuring Dolby metadata insertion in the output SDI data stream.

Insertion Config

Insertion – use the pulldown to turn Dolby metadata insertion ON or OFF

Insertion Line – use the pulldown to select the insertion line. The range of values varies with the video format

Mode – use the pulldown to select between:

- Auto – insert the Dolby metadata from the input stream if available; otherwise insert the out-put of the IRD-3811's internal generator.
- Generator – insert Dolby metadata from the internal generator at all times when insertion is ON.

Dialnorm Override – select the checkbox to override the dialnorm value included in the metadata, and use the pulldowns in the Generator Config section to set new values.

Generator Config

Profile – use the pulldowns to select the generator profiles for programs 1 and 2. Profiles 1, 2, 3 and 4 are the available choices.

- See Annex 2 on page 57 for a listing of the parameter values in the four profiles

Dialnorm – Use these pulldowns to manually set a dialnorm value for the two audio programs, overriding the current value. These pulldowns are only active when the Dialnorm Override box is checked

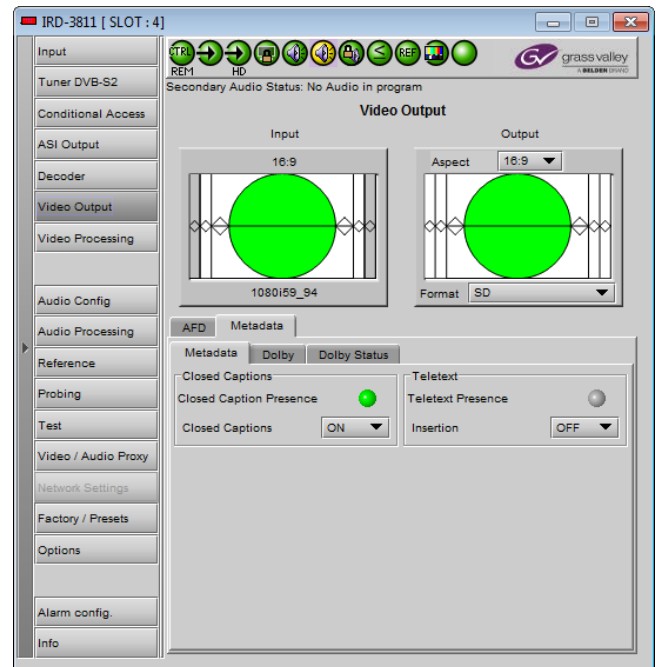

Figure 3.11 Video Output panel – metadata/metadata

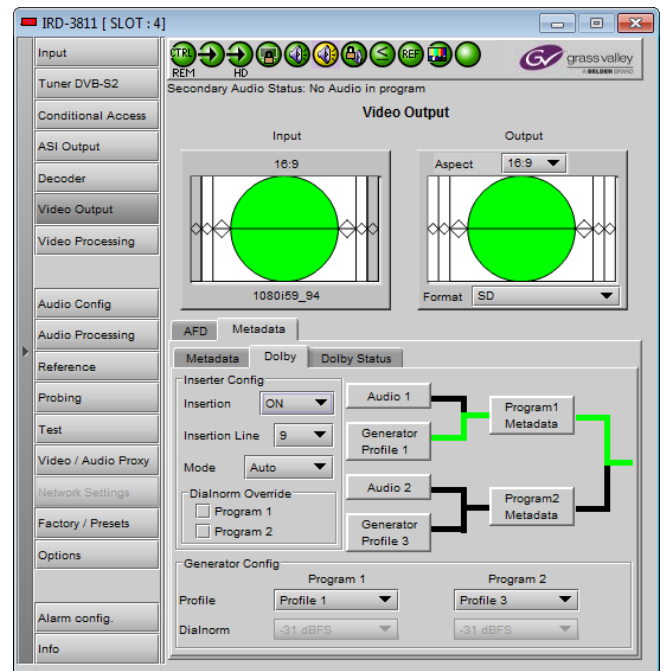

Figure 3.12 Video Output panel – Metadata/Dolby

3.4.7.4 Metadata / Dolby Status tab

This panel reports the status of Dolby metadata associated with the two audio programs

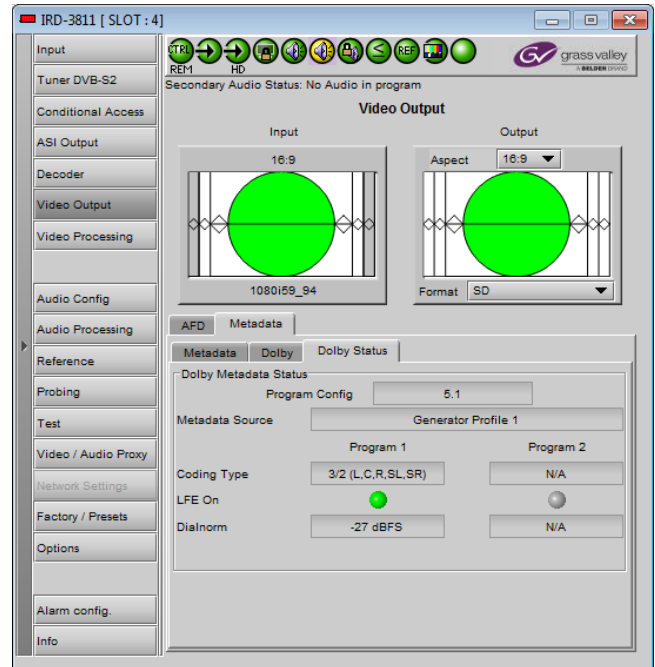

Figure 3.13 Video Output – Metadata/Dolby Status

3.4.8 The Video Processing panel

The IRD-3811 includes basic proc amp functions for the analog video output.

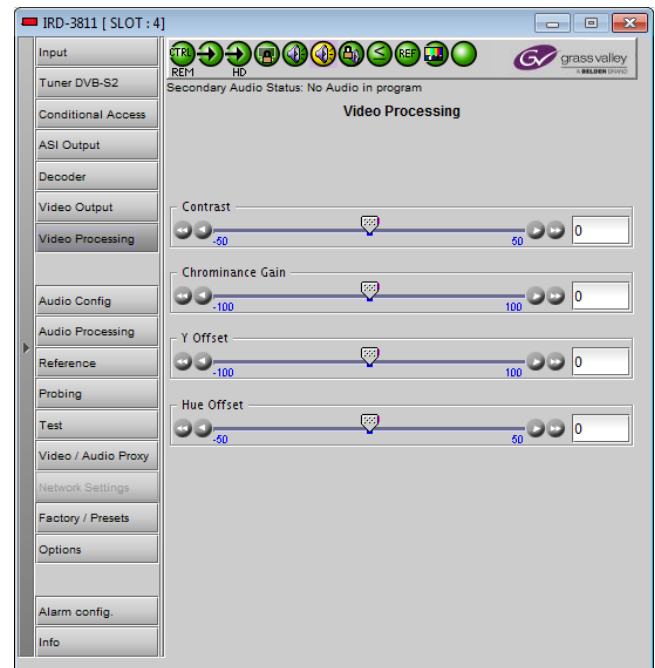

Figure 3.15 Video Processing panel

3.4.9 The Audio Config panel

This panel provides controls for configuring the Dolby AC3 decoder and analog audio outputs, and for monitoring some audio parameters

3.4.9.1 Config tab

Dolby Audio Decoder (AC3)

Decoder Operation

Audio 1 and Audio 2 can each be set to:

- Decode
- Pass-through, bypassing the decoder and audio processing functions

Downmix mode – select the downmix mode individually for Audio 1 and Audio 2:

- Lt/Rt – Dolby “unofficial” pro-logic compatible
- Lo/Ro – normal stereo

Dynamic Range Compression (DRC) – Use the pulldown to set DRC ON or OFF

DRC Profile – Use the pulldown to set the DRC profile to Line mode or RF mode.

A / V Sync Offset – Use the slider or type into the data box to set the audio./video sync offset to a value between 0 and 100 msec.

Audio Embed – use the pulldown to set audio embedding ON or OFF

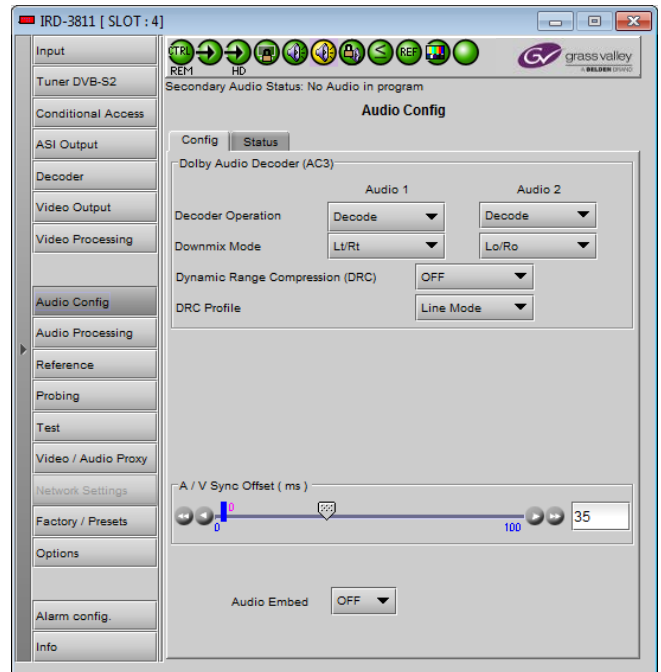

Figure 3.16 Audio panel – Config tab

3.4.9.2 Status tab

This tab contains text boxes and status icons that indicate the current status of the IRD-3811’s audio processing. Audio 1 and Audio 2 are shown in separate columns

- Audio presence (status icon)
- Audio PID
- Audio Type
- Sample Rate
- Output Mode

AC3 Audio Status (BSI)

- Service (bsmod)
- Coding Type (acmod)
- Bit Rate
- LFE presence (status icon)
- Dialnorm



Figure 3.17 Audio panel – Status tab

3.4.10 The Audio Processing panel

NOTE: The OPT-FS option must be purchased in order to enable this panel

3.4.10.1 Shuffling tab

The audio program inputs to the IRD-3811 are placed into the four AES channels embedded in the IRD-3811 ASI output. The placement depends on the setting made in the Decoder Operation pulldown in the Audio Config panel, Config tab.

Decode mode:

If the input audio programs have passed through the decoder:

- the decoded outputs from Audio 1 (5.1 program which is decoded to six discrete channels), are grouped into three pairs of two channels (Left/Right; Center/LFE, and Ls/Rs) and each pair is assigned to one AES.
- The decoded outputs from Audio 2 (stereo program) are grouped as a pair (Left/Right) which is assigned to one AES

Pass-Through Mode:

If the decoder has been bypassed (Decoder Operation pulldown set to *Pass-Through* in the Audio Configuration panel) for either of the programs:

- The non-decoded audio (AC3) will be inserted into one of the output AES channels
- Only the AC3 element is available in this case; the decoded program element pairs shown in the figure do not exist

The default assignment is as shown in figure 3.18.

- Click the radio buttons to change the assignment
- A program element pair or AC3 program can be assigned to more than one AES if desired.

3.4.10.2 Levels tab

The levels of the six decoded channels in Audio 1, and the two decoded channels in Audio 2, can be adjusted using the sliders in this panel. Alternatively, values can be typed directly into the data boxes.

- These controls are not available when the *Pass-Through* mode is selected in the Decoder Operation pulldown in the Audio Config – Config tab.

Select the *Locked* checkboxes to tie the indicated pairs of channels together.

- Either slider will adjust both channels together.

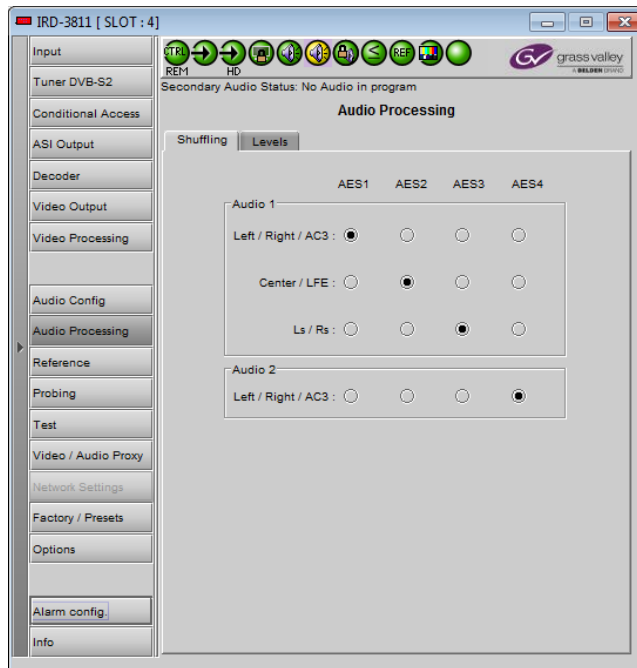

Figure 3.18 Audio Processing – Shuffling tab

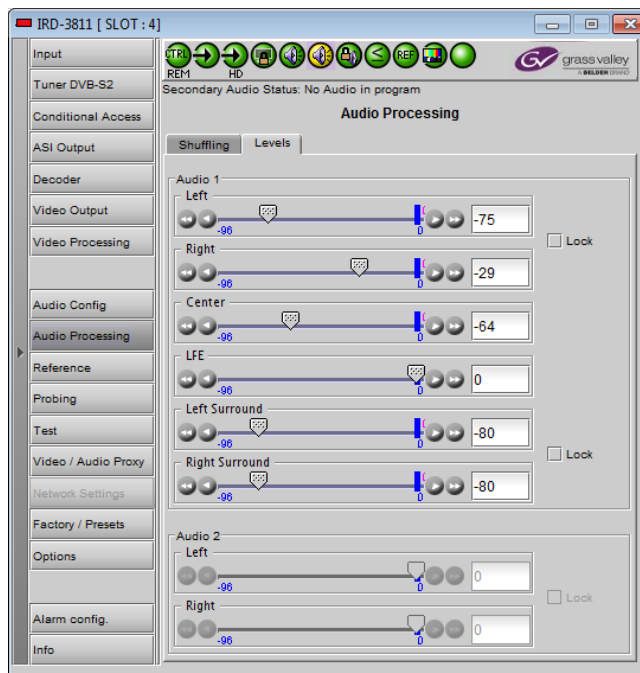

Figure 3.19 Audio Processing – Levels tab

- Any offset between them when the *Locked* checkbox is selected will remain in effect.

3.4.11 The Reference panel

NOTE: The OPT-FS option must be purchased in order to enable this panel. Otherwise the reference is always taken from the input signal.

The IRD-3811 output signals should always be genlocked to some reference source. The genlock source is selected in the Reference control panel. Use the radio buttons in the Reference Source area to select from the following options:

- Auto – this mode selects the first source detected in this order of priority:
 - External
 - URS
 - Selected Input signal
- External – selects the signal connected to the rear-panel REF IN connector
- 525 from URS (Universal Reference Signal) – selects the internal reference (525) from the backplane
- 625 from URS (Universal Reference Signal) – selects the internal reference (625) from the backplane
- Input – uses the currently-selected input signal.



Figure 3.20 Reference Panel

The *Used Reference* box shows the reference currently in use, which is helpful in Auto mode

Vertical (lines)

With this adjustment, a value ranging from 0 to +200 lines, compared to the reference or the processing delay, may be set. This adjustment can be used in conjunction with the horizontal timing adjustment.

Horizontal (µsec)

With this adjustment, a value ranging from zero to the equivalent of 1 horizontal line in the current operating format (e.g. ranging from 0 to 63.46 µs for 525-line operation; 0 to 64.00 µs for 625-line operation; etc) compared to the reference or the frame boundary, may be set.

Additional Frame Delay

Use the pulldown to select an extra frame delay to be added to the output.

- Choices: 0, 1, 2 or 3 frames

NOTE: if the output format is interlaced, only 1 frame can be added. In progressive 720p, up to 3 frames are allowed.

3.4.12 The *Probing* panel

NOTE – the TS Probing option must be purchased in order to enable this panel.

3.4.12.1 Structure tab

Shows the structure of the transport stream

Click on the nodes in the tree to expand it to examine areas of interest,

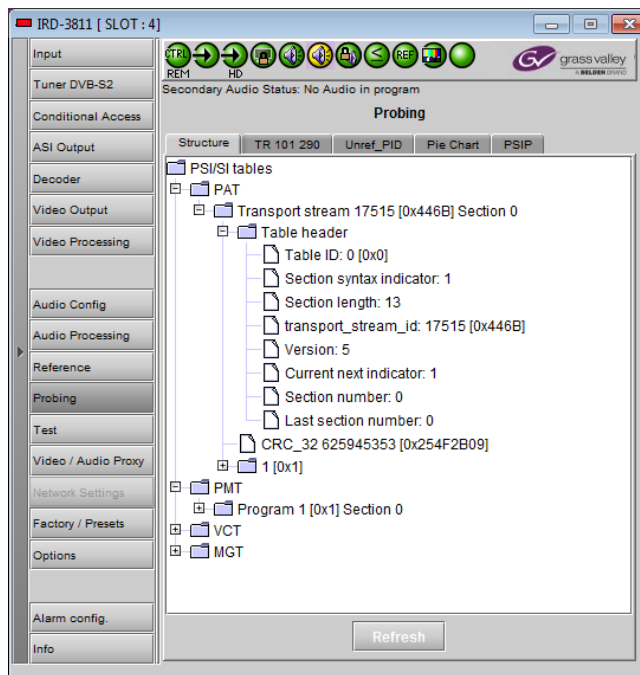

Figure 3.21 Probing panel – Structure tab

3.4.12.2 TR 101 290 tab

This tab shows the results of the tests against the TR 101 290 standard.

Click in the checkbox at the bottom to enable or disable display updating (about once per second).

The time-out value for each of the probed values can be set by the user.

- Double-click on the current value to open the data box, and enter a new value.



Figure 3.22 TR 101 290 tab

3.4.12.3 Unref_PID tab

This tab provides a list of all unreferenced PIDs found in the incoming service.

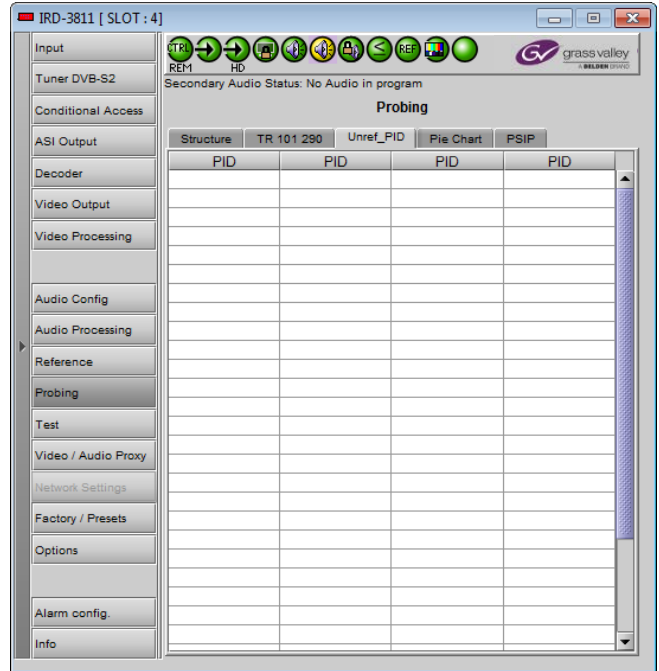

Figure 3.23 Probing panel – Unref_PID tab

3.4.12.4 Pie Chart tab

This tab displays the incoming service in the form of a pie chart, with color-coded segments representing the various elements in the service.

- This representation illustrates the bandwidth distribution within the service.

The table below the chart shows all of the elements, identifying each by name, PID and bandwidth.

- Click on a name in the table, and the corresponding slice of the pie will slide out from the chart
- Click on a slice of the pie; it will slide out and its program name in the table will be highlighted.
- Mouse-over a slice and the associated Program Name will pop up.

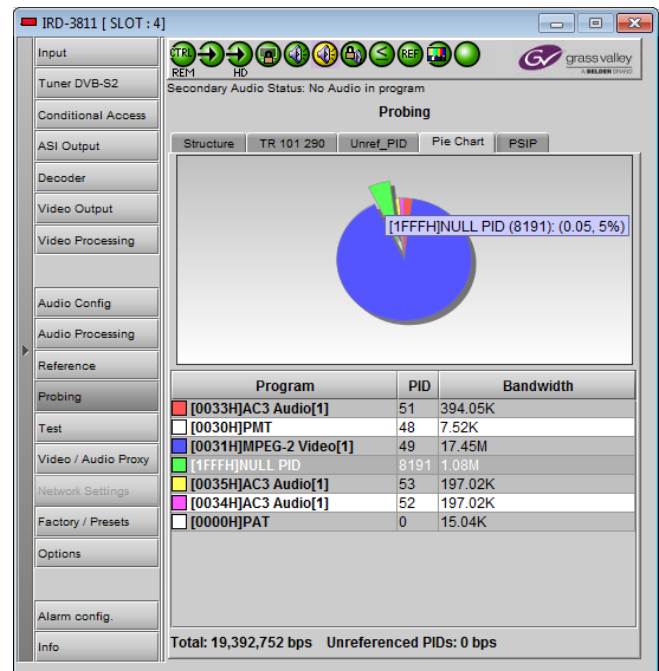

Figure 3.24 Probing panel – Pie Chart tab

3.4.12.5 PSIP tab

This tab is an information-only tab that documents various aspects of the incoming service

(Shown for ATSC input via the ASI input only; tab will not be available when DVB-S2 from the tuner input is selected)



Figure 3.25 Probing panel – PSIP tab

3.4.13 The Test panel

Use the Color Bars checkbox to turn the Test function ON or OFF

- When **checked**, the output signal is replaced by Color Bars.
- When **unchecked**, the normal program signal is present at the output.
- The icon at the top of the window (second from the right) shows the status of the color bars.



Figure 3.26 The Test panel

3.4.14 The Video / Audio Proxy panel

This panel sets up video proxy streaming and displays the video image. It also displays an audio level meter

Player tab

RAW data presence – status icon indicating the card is sending a proxy feed to the iControl service. When green, the player can be used to decode the stream and look at the picture.

Current Frame Rate – value reported of the current frame rate of the proxy stream. In AUTO frame rate mode, this shows the frame rate currently selected.

Video Player – Use the radio buttons to select OFF or Video

Audio Player – Use the radio buttons to select OFF or Audio

H.264 Proxy Enable – use the pulldown to select OFF or H264 proxy (you cannot turn the Video Player ON unless this is selected)

Size – use the pulldown to select Medium or Small for the video display

Frame Rate – use the pulldown to select an appropriate frame rate to display the video

- As Input, 20 fps, 15 fps, 10 fps, 5 fps.

See section 4.8 for more information about proxy video streaming

Audio – Enable: select the checkbox to enable audio metering (you cannot turn the Audio Player ON unless this box is selected).

Left Src; Right Src – use these two pulldowns to select the audio sources for the left and right audio meters

- Left, Right, Center, LFE, Left Surround, Right Surround, Aux Left, Aux Right

Meter Ballistics Config tab:

Type pull-down box: this pull-down offers a list of the available meter types, whose ballistics are identified by the standard to which they conform.

Upper Zone Limits (dB) :select the crossover level between the upper and middle zones of the meter (the range of values shown in the pull-down list depends on the type of meter selected)

Lower Zone Limits (dB): select the crossover level between the middle and lower zones of the meter (the range of values shown in the pull-down list depends on the type of meter selected)

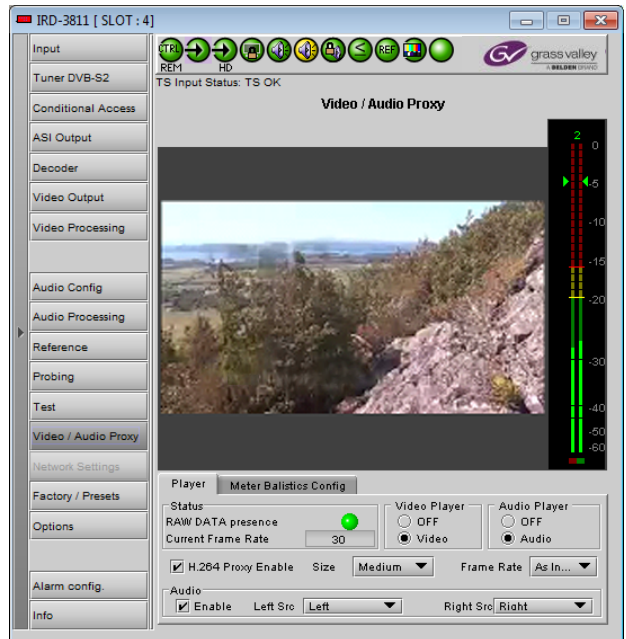

Figure 3.27 Video / Audio Proxy panel

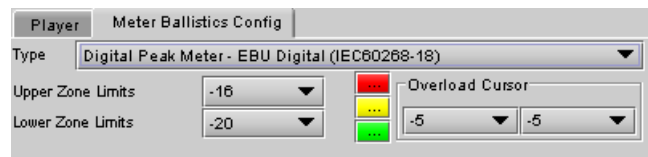
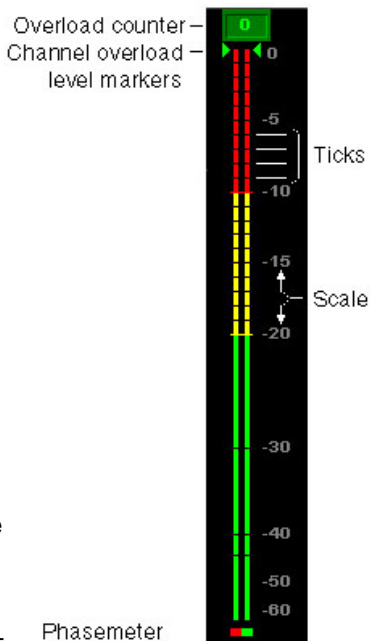

Figure 3.28 Meter Ballistics tab

Color samples : the three samples show the current selected color for the upper, middle and lower zones of the meter. Click on the color sample of a zone to open a color selection panel to choose a different color for that zone.

Overload Cursor (dB): The overload cursor appears on the meter as an arrowhead in the meter scale. The two pull-down boxes set the position of the overload cursor on the left and right meters (the range of values shown in the pull-down list depends on the type of meter selected).



Meter functionality:

- The meter is divided into three zones:
- The dividing points are specified in the Upper Zone Limits and Lower Zone Limits boxes. Click in the box and scroll to the desired value.
- The color of the meter in each zone is selectable. Click on the colored square corresponding to the zone to open a color selection dialog.
- The level at which the channel is to be considered in Overload can be specified using the Channels Overload boxes. Click in the box to see a scrollable list, and select the desired level.
- The Overload Counter shows a running count of the number of overloads detected
- The Phasemeter is a small meter that represents the phase correlation factor between the two channels of a pair.

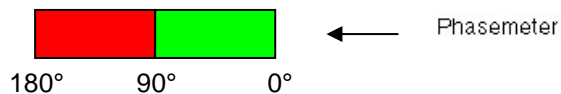

Figure 3.29 Audio meter configuration

3.4.15 The Network Settings panel

This panel is only available when the ETH Option has been activated.

Settings tab

ETH Port Status

The status of the ethernet link is shown by the icons:

- Link is down (red)
- Link is OK (green)

NOTE: This is the equivalent to the green LED on the rear-panel ETH connector.

ETH Port Direction

Use the pull-down to select the Ethernet port functionality. Options are:

- Disabled – not functional
- Input – receives a transport stream
- Output – sends transport stream

IP Config

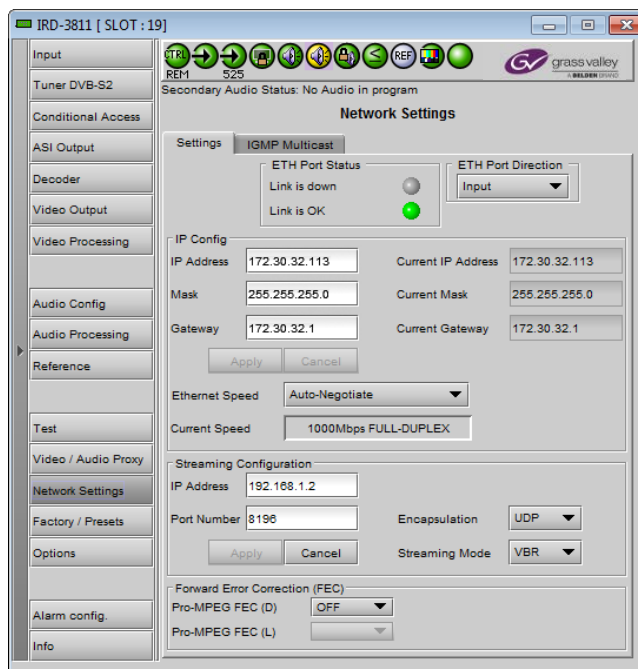

Figure 3.30 Network Settings panel – Settings tab

This section displays the current IP settings on the right, and provides data boxes to enter new values on the left.

IP Address }
Mask } static network parameters
Gateway }

Enter the new values directly into the data boxes. The changed data will show in red.

- Press **Apply** to apply the new values, or **Cancel** to leave the current values unchanged.

Current IP Address / Current Mask / Current Gateway – these are the current values for this card.

Ethernet Speed: use the pulldown to select the ethernet speed. Options are:

- Auto-Negotiate
- 10 Half Duplex (10 Mbps)
- 10 Full Duplex (10 Mbps)
- 100 Half Duplex (100 Mbps)
- 100 Full Duplex (100 Mbps)

Note that the IEEE standard does not permit forcing to 1000Mbps.

Current Speed – the data box reports the current speed

Streaming Configuration

IP Address

This is the unicast or multicast address for the source or destination.

Port Number

This is the port on which the signal is present. This is valid for either transmitting or receiving. If this port does not correspond to the source, no signal will be received.

Enter the new values directly into the data boxes. The changed data will show in red.

- Press **Apply** to apply the new values, or **Cancel** to leave the current values unchanged.

Encapsulation

Select the IP protocol to use to stream packets.

- RTP
- UDP

Streaming Mode

Specify the type of bitstream arriving at the IP inputs for conversion to ASI. This setting controls the jitter removal system. This system only works with constant bit rate streams (CBR). In order to adequately pass VBR streams, the jitter removal system has to be disabled.

Use the pulldown to select between:

- VBR (Variable Bit Rate streams are received)
- CBR (Constant Bit Rate streams are received)

Forward Error Correction (FEC)

Forward Error Correction (FEC) is only available in RTP mode. This setting will allow inserting FEC codes into the stream when the port is sending data. On reception, FEC is automatic.

Pro-MPEG FEC (D) pulldown: [OFF, 4, 5, 6, ..., 19, 20]

Pro-MPEG FEC (L) pulldown: (not active when OFF is selected in the FEC (D) pulldown)

IGMP Multicast tab

The Internet Group Management Protocol (IGMP) at v3 supports the filtering of up to 59 defined IP addresses, allowing them to limit the range of sources that the receiving device can access, either by excluding all other addresses (*Accept* mode) or by excluding the listed addresses and accepting all others (*Reject* mode).

The list of addresses is entered manually in this window:

- Click ADD to open a new blank line in the panel, or click on an existing line to edit it
 - The ADD button then changes to a SAVE button
- Manually type the beginning and ending addresses of a block of source IP addresses in the *IP Beginning* and *IP End* data boxes
 - If the address is not legal, a pop-up warning will appear and the input will not be accepted
- The total number of addresses in the block is calculated and appears on the right of the line
- Multiple blocks can be defined, but the total number of addresses in them cannot be greater than 59. The overall total is shown at the bottom right of the window.
- Click SAVE to store the line, or CANCEL to terminate the session without making changes
- To delete a line in the window, click on one of its data boxes and click REMOVE.

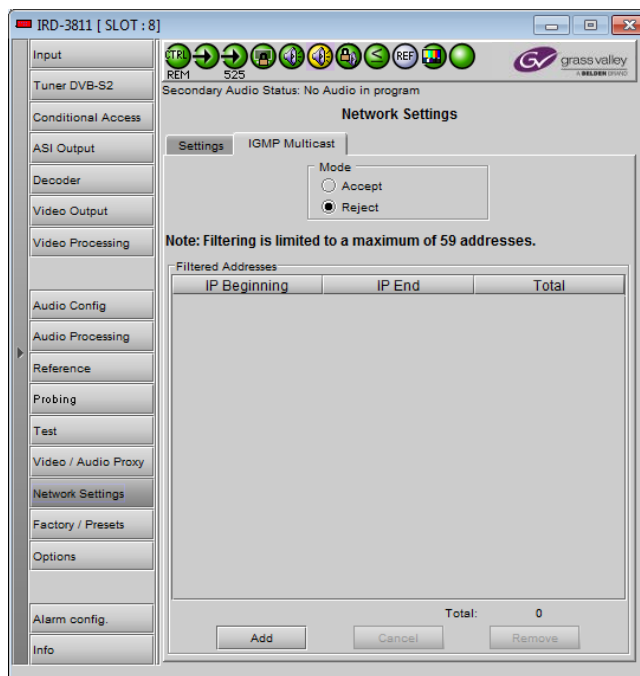

Figure 3-31 Network Settings - IGMP Multicast tab

3.4.16 The Factory/Presets panel

This panel provides resources for saving, restoring and transferring the configuration settings of this IRD-3811.

Load Factory

The IRD-3811 maintains a “Factory Default” alignment in its memory, to which it can be restored at any time.

- Click the *Load Factory* button to restore the card to its Factory default alignment.

User Presets

The User Preset controls allow the user to save and recover all configuration settings on the card.

Select any one of the five presets using the pulldown list. The name of the currently-selected User Preset is shown on the on the pulldown icon (e.g. *User1*, *User2*,... *User5*)

- Click *Load* to load the contents of the selected User Preset into the IRD-3811. All parameter settings and



Figure 3.32 Factory / Presets Panel

values will be replaced by the contents of the selected User Preset.

- Click **Save** to store the current parameter settings and values from the IRD-3811 into the selected User Preset. The existing contents of the preset will be overwritten.

Profiles

This section provides resources to save and recover the entire card configuration (including user presets if desired) on an external disk, or to copy it to another IRD-3811 card.

Click on *Profiles* to open the Profile Copy window.

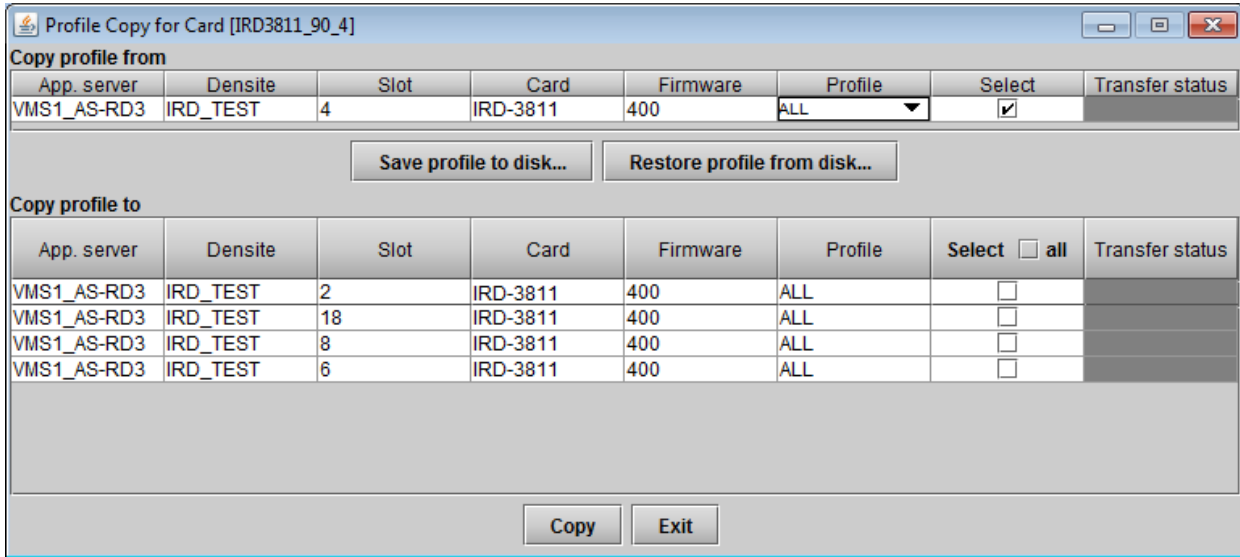

Figure 3.33 Profile Copy window

Copy Profile From:

This section shows this IRD-3811 card, and identifies it by App server, Densité frame and slot number, card type and firmware version.

The *Profile* column has a pulldown that allows you to select which profiles you will work with, and gives these choices:

- Current, User1, User2, User3, User4, User5, ALL

The *Select* column includes a checkbox, preselected as checked, to confirm that you want to work with the current card

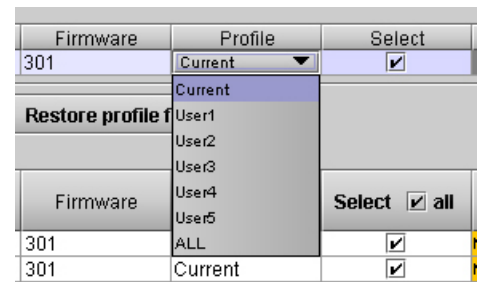

Figure 3.34 Select profile to copy

Save Profile to Disk...

Click this button to open a Save dialog allowing you to specify a file name and location to which the selected profiles for this card will be saved.

Hint - It is a good idea to create a folder for these files, because they are not explicitly identified as IRD-3811 profiles, and will be difficult to find and identify if not clearly named and conveniently located.

- Click the save button once the name and location have been identified in the Save box
- If the file is saved correctly, the Transfer Status box on the right of the *Copy profile from* line will indicate *Succeeded* against a green background
- If the file was not saved for some reason, the Transfer Status box to the right of the *Copy profile from* line will indicate *Failed* against a red background

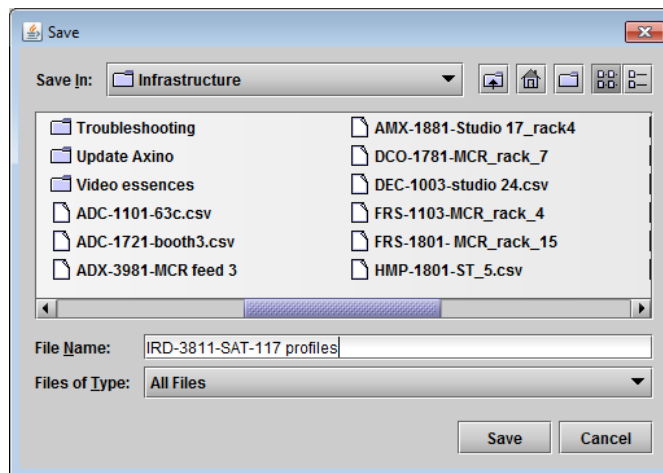

Figure 3.35 Save Profile to disk

Restore profile from disk...

Click this button to open an *Open* dialog box within which you can locate and select a valid IRD-3811 profile file.

- Click Open to read the contents of the file and to reconfigure this IRD-3811's profiles according to its contents
- While the reconfiguration is in progress, the Transfer Status box on the right of the *Copy profile from* line will indicate *Working* against a yellow background
- When the reconfiguration is complete, the Transfer Status box on the right of the *Copy profile from* line will indicate *Succeeded* against a green background

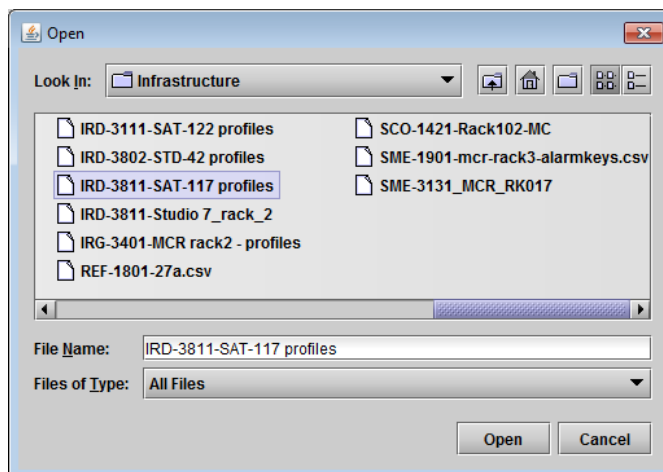

Fig 3.36 Restore profile from disk

Note: There is no need to select a profile using the Profile pulldown (e.g. current, User1, etc.) when restoring a profile from disk, because the profile selection is stored within the file.

Copy profile to section

This line shows other IRD-3811 cards that are available on the iControl network, each identified by App server, Densité frame and slot number, card type and firmware version.

The *Profile* column shows the same information as is shown for the current card in the *Copy profile from* line, i.e.

- Current, User1, User2, User3, User4, User5

The *Select* column includes a checkbox to identify which IRD-3811 cards you wish to copy profiles into from the current card.

- For convenience, a *Select all* checkbox is provided in the column header

Click *Copy* to copy the selected profiles from this card into the selected other IRD-3811 cards

- While the profile copy operation is in progress, the Transfer Status box on the right of the *Copy profile to* line will indicate *Working* against a yellow background

- When the profile copy operation is complete, the Transfer Status box on the right of the *Copy profile to* line will indicate *Succeeded* against a green background

3.4.17 The *Options* panel

This panel provides an entry point for activating the five options available for the IRD-3811. Each option is accessed on a separate tab.

Frame Sync option

This option provides frame synchronization of the decoded signal to the external signal connected to the REF IN connector on the rear panel.

The option also activates the advanced audio processing functions.

To activate this option, you must:

- Obtain a licence key from Grass Valley.
- Type the licence key in the box
- Click on ENABLE OPTION to enable the option's features.

The information window beneath the key entry box indicates whether the option is activated (green) or not (gray).

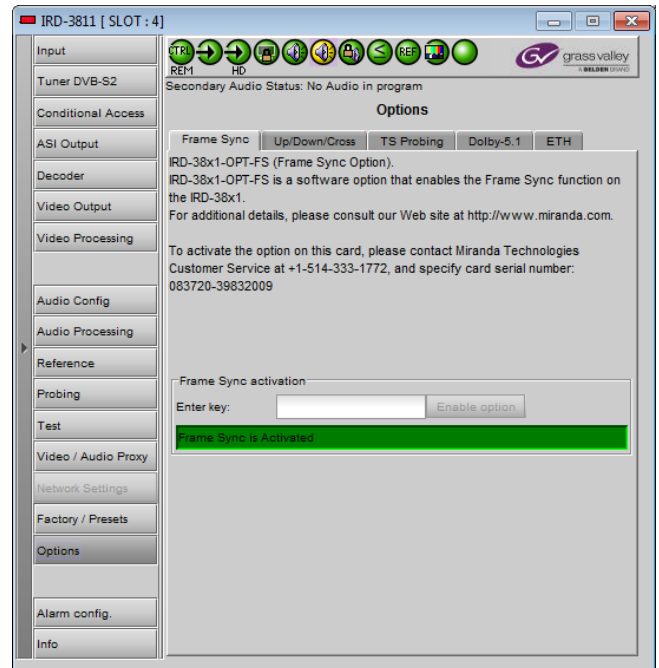

Figure 3.37 Options panel – Frame Sync

Up/Down/Cross option

This option enables up-conversion (SD-to-HD), down-conversion (HD-to-SD) and cross-conversion (HD-to-HD) functionality on the IRD-3811.

To activate this option, you must:

- Obtain a licence key from Grass Valley.
- Type the licence key in the box
- Click on ENABLE OPTION to enable the option's features.

The information window beneath the key entry box indicates whether the option is activated (green) or not (gray).



Figure 3.38 Options panel – Up/Down/Cross

TS Probing option

This option activates the Transport Stream probing functions of the IRD-3811.

To activate this option, you must:

- Obtain a licence key from Grass Valley.
- Type the licence key in the box
- Click on ENABLE OPTION to enable the option's features.

The information window beneath the key entry box indicates whether the option is activated (green) or not (gray).

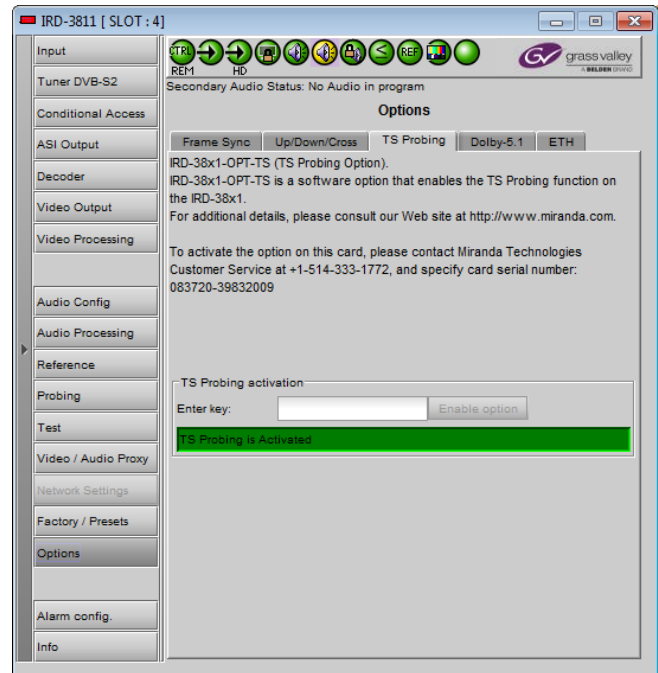

Figure 3.39 Options panel – TS Probing

Dolby 5.1 option

This option enables the Dolby 5.1 output on 6 discrete channels

Note – Dolby 5.1 decoding is always enabled

To activate this option, you must:

- Obtain a licence key from Grass Valley.
- Type the licence key in the box
- Click on ENABLE OPTION to enable the option's features.

The information window beneath the key entry box indicates whether the option is activated (green) or not (gray).

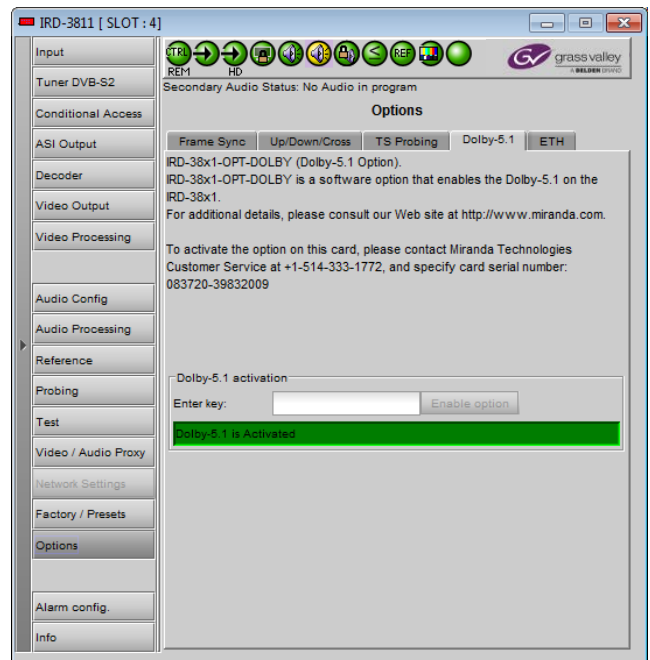

Figure 3.40 Options panel – Dolby 5.1

ETH option

This option enables the ethernet port on the rear panel of the IRD-3811.

To activate this option, you must:

- Obtain a licence key from Grass Valley.
- Type the licence key in the box
- Click on ENABLE OPTION to enable the option's features.

The information window beneath the key entry box indicates whether the option is activated (green) or not (gray).



Figure 3.41 Options panel - ETH

3.4.18 The Alarm Config panel

This panel allows the alarm reporting of the IRD-3811 to be configured. The panel opens in a new window when the button is clicked, and can be resized if needed.

The panel is organized in columns.

Status/Name

This contains an expandable tree listing all the alarms reported by this IRD-3811 card.

- Each alarm name includes an icon that shows its current status
- Some alarms may be text-only and the alarm status is shown in the name and not by a status icon, e.g.

- Card Message (Warning: PAT Table timeout!)
- Selected Audio Type (AC3)

The **Card LED**, **Overall alarm** and **GSM contribution** columns contain pulldown lists that allow the level of contribution of each individual alarm to the alarm named in the column heading to be set.

- Click on the alarm icon to see the available levels; then click on one to select it

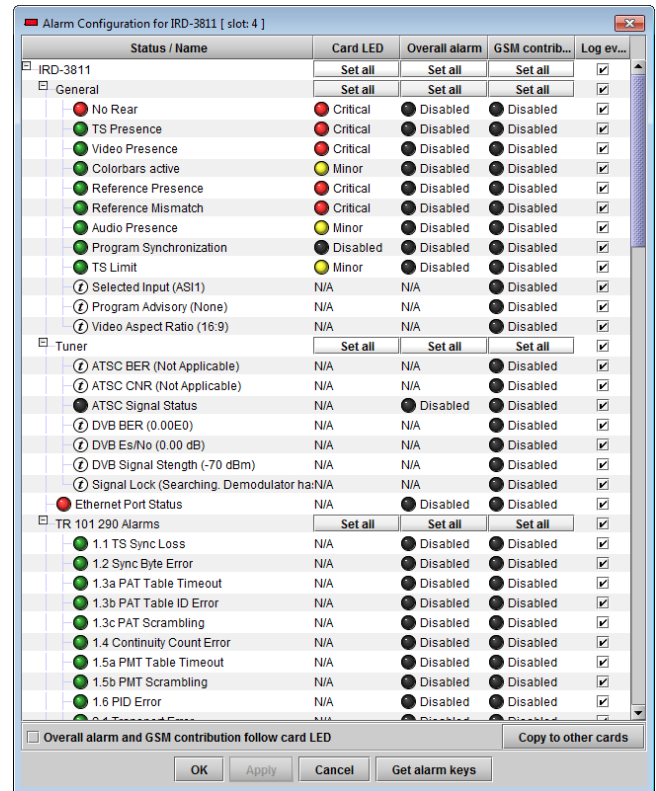







Figure 3.42 Alarm Configuration Panel

Levels associated with these alarms:

The pulldown lists may contain some or all of the following options:

- | | |
|---|---|
|  Disabled | The alarm makes no contribution (black icon) |
|  Minor | The alarm is of minor importance (yellow icon) |
|  Major | The alarm is of major importance (orange icon) |
|  Critical | The alarm is of critical importance (red icon) |
|  Passthrough | The alarm exists but has no effect (used for text and composite alarms) |

Shortcut: if you click in one of the Set All boxes beside a section heading, you will open a pulldown that lets you assign a level to all alarms in that section of the column simultaneously.

• **Card LED**

This column allows configuration of the contribution of each individual alarm to the state of the Status LED located on the front panel this card.

• **Overall Alarm**

This column allows configuration of the contribution of each individual alarm to the Overall Alarm associated with this card. The Overall Alarm is shown in the upper left corner of the iControl panel, and also appears at the bottom of the Status/Name column.

• **GSM Contribution**

This column allows configuration of the contribution of each individual alarm to the GSM Alarm Status associated with this card. GSM is a dynamic register of all iControl system alarms, and is also an alarm provider for external applications. The possible values for this contribution are related to the Overall alarm contribution:

- If the Overall alarm contribution is selected as Disabled, the GSM alarm contribution can be set to any available value
- If the Overall alarm contribution is selected as any level other than disabled, the GSM contribution is forced to follow the Overall Alarm.

Once the alarms are configured, you may accept the changes or discard them:

Log Events

iControl maintains a log of alarm events associated with the card. The log is useful for troubleshooting and identifying event sequences. Click in the checkbox to enable logging of alarm events for each individual alarm.

At the bottom of the window are several other controls:

Overall alarm and GSM contribution follow card LED

Click in the checkbox to force the Overall alarm and GSM contribution to be identical to the Card LED status

- All Overall alarms for which there is a Card LED alarm will be forced to match the Card LED alarm
- All Overall Alarms for which there is no Card LED alarm will be forced to Disabled

A warning box will open allowing you to confirm the action, since it will result in changes to the configuration and there is no *undo* function.

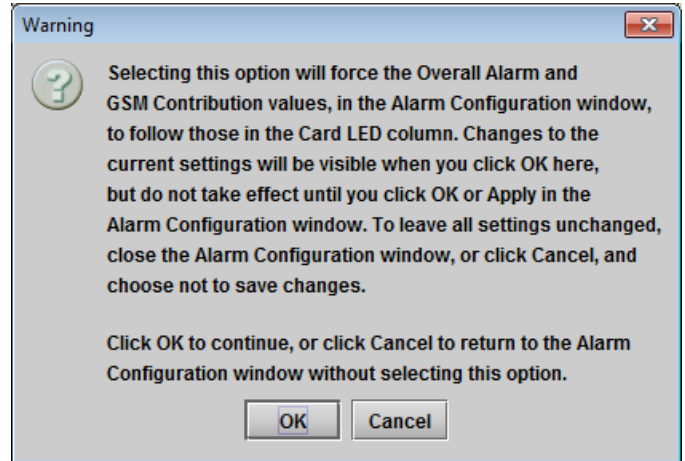

Figure 3.43 Warning for Follow LED change

Copy to other cards

Click this button to open a panel that allows the alarm configuration set for this card to be copied into another IRD-3811 card.

- Select one or more destination cards from the list in the window by clicking in the checkboxes, or all of them by clicking in the *All* checkbox
- Note that when you do a Copy Profile for this card (see Sect.3.4.16), the alarm configuration is copied along with all the other settings.

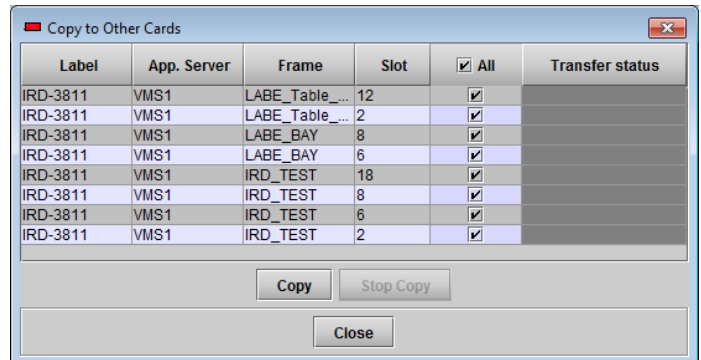

Figure 3.44 Copy to other cards

Get alarm keys

Click this button to open a save dialog where you can save a file containing a list of all alarms on this card and their current values, along with an Alarm Key for each. The alarm keys are useful for system integration and troubleshooting.

- The file is saved in Excel.csv format

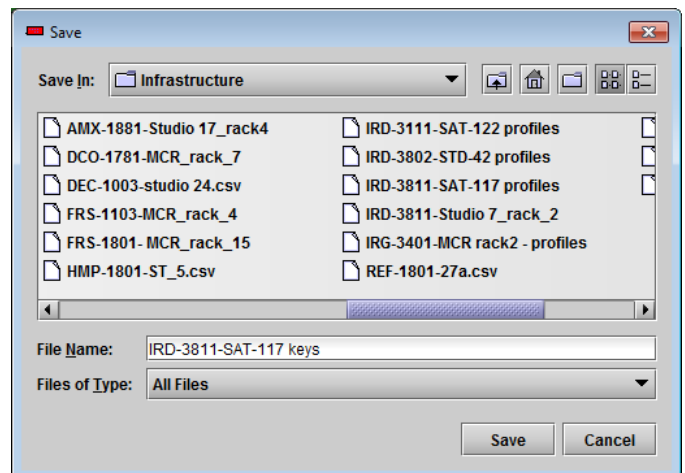

Figure 3.45 Get alarm keys save dialogue

OK, Apply, Cancel

- **OK** accepts the settings and closes the window once the card confirms that there are no errors.
- **Apply** accepts the settings, but leaves the window open
- **Cancel** closes the window without applying any changes, and leaves the previous settings intact.

3.4.19 The Info panel

3.4.19.1 Info tab

When the IRD-3811 is included in an iControl environment, certain information about the card should be available to the iControl system. The user can enter labels and comments that will make this card easy to identify in a complex setup. This information is entered via the Info control panel. This panel also shows other information about the card.

Label: type the label that appear for this IRD-3811 when it appears in iControl applications

Short Label type the short-form label that iControl uses in some cases (8 characters)

Source ID type a descriptive name for this IRD-3811

Comments: type any desired text



Figure 3.46 Info Panel

The remaining data boxes show manufacturing information about this card.

- Details...: Reports the Firmware version, service version, and panel version for this card

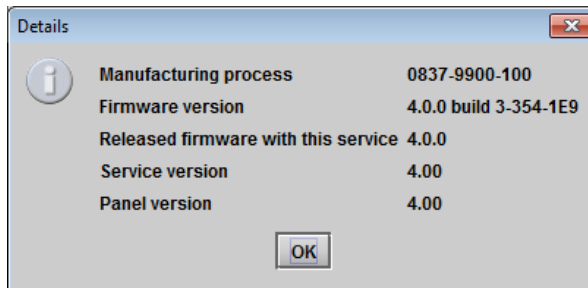

Figure 3.47 Details window

- Advanced...: Shows the LongID for this card. The LongID is the address of this IRD-3811 in the iControl network.

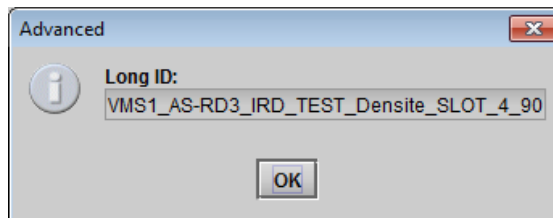

Figure 3.48 Advanced window

- Remote System Administration – opens the Joining Locators data box, which lists remote lookup services to which this IRD-3811 is registered.

Add: Force the iControl service for this IRD-3811 to register itself on a user-specified Jini lookup service, using the following syntax in the data box:

jini://<ip_address>

where <ip_address> is the ip address of the server running the lookup service, e.g.:

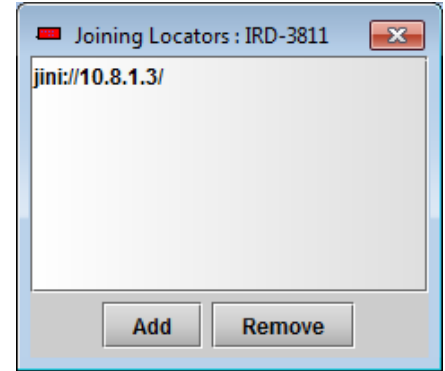
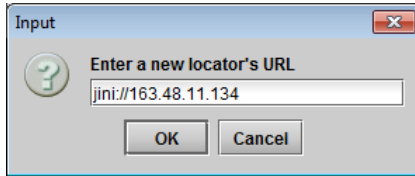
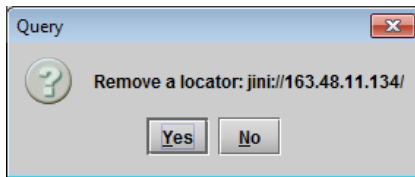

Figure 3.49 Joining Locators

Remove: select one of the services listed in the window by clicking on it, and click *Remove* to open a query box allowing you to delete it from the window.



3.4.19.2 Message Console tab

The Message Console provides a log of various status messages generated on-board the card.

- Newest messages appear at the bottom of the list
- Use the scroll bar to view the entire list

Click the *Clear Messages* button to empty the message window.

This panel is primarily provided for diagnosis purposes. Hardware and transport stream error messages are sent to this panel, along with card activity status reports.

Reset Card...: Use this button to reset the card.

For various reasons, some CAM cards may stop decrypting, stop passing the stream or even freeze. When that happens, the only way to recover is to reset the CAM. This involves putting it through a power off/power on cycle. This can be done by physically removing it from its slot and then reinserting it. Alternatively, resetting the IRD-3811 will also reset the CAM, and this can be done remotely via this iControl panel

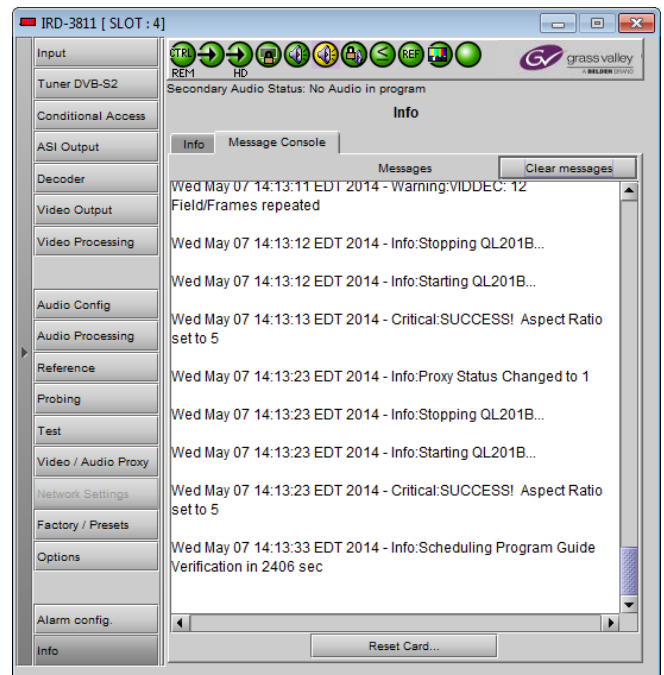
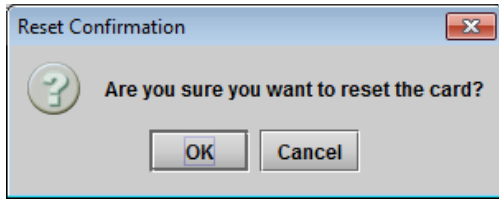

Figure 3.50 Message Console

GUIDE TO INSTALLATION AND OPERATION

When you click the button, you will be presented with a dialog allowing you to confirm your decision to reset, or to cancel the reset.



4 User Reference Guide

4.1 Decoding MPEG Transport Streams

The user can input DVB-ASI signals up to 80 Mbps on either ASI input connector. Alternatively, the Ethernet can be configured to receive an IP stream (see section 3.4.15).

- ⊕ To select an input, go to the **Input Menu** and then **Input Selection**

Once a valid transport stream signal enters the decoder, the first valid service found is decoded automatically (AUTO selection mode only) if no selection was previously made. If the previously-selected service does not exist in the stream, the IRD picks the first found in the PAT. The secondary audio will be set to NONE by default while the first-found audio stream will be selected.

In order for a service to be decoded, the following conditions must be met:

- a) The transport stream must be ISO 13818-1 compatible
 - b) The video stream must be MPEG2 in the 4:2:0 color profile
 - c) The audio stream can be MPEG1 layer 2, MPEG2, AC3 or AAC-LC
 - d) The video bit rate is not more than 26Mbps
 - e) The transport stream bit rate is below 80Mbps
- ⊕ To select a service within the transport stream, go to the **Input Menu** into **Service Select**. For iControl, please refer to section 3.4.6. The name of the service will be displayed when available (the name is as per ATSC VCT and is unavailable for non-ATSC streams). When the service name is not available, the card displays the service number as per PAT.

-
- ➔ Audio-only services can be decoded; the output display will be blacked.
 - ➔ 4:2:2 video will not generate any errors but the display will be fuzzy
 - ➔ The IRD has a maximum parsing capability of 64 services per transport stream. An error is generated if the stream has more services, and only the first 64 entries of the PAT will be selectable.
 - ➔ Whenever the stream cannot be decoded, the outputs are set to freeze or black according on user selection.
 - ➔ Any change in PAT or PMT will trigger the service selection system. This makes it possible to use in an ASI hot-switch context.
-

4.2 Decoding Audio

The IRD-3811 can decode 2 audio streams simultaneously.

If no audio PID was previously selected or if the selected PID does not exist, the IRD automatically selects the first found audio in the corresponding PMT.

The following audio coding formats are currently supported:

- AC3 audio up to 5.1 channels

- MPEG1 Layer II
- MPEG2 Audio
- AAC audio (2 CH or AAC-LC)

The first audio can be embedded as 5.1 discrete channels (the Dolby option is required to get discrete channels; otherwise you get 2 down-mixed channels) while the second audio is always output as 2 channels. Downmix mode can be selected between Lt/Rt or Lo/Ro modes independently for both audios.

The primary and secondary audio can be set in pass-through mode for AC3 data streams. This allows embedding raw AC3 streams into the SDI signal.

-
- ➔ Audio only services can be decoded
 - ➔ Audio PIDs not belonging to the current service cannot be selected
 - ➔ Only supported audio streams will be available to the user for selection
 - ➔ Audio 1 is embedded on AES channels 1 to 6, Audio 2 is on channels 7-8 by default. The user may set up a different configuration.
 - ➔ The Dolby option must be activated to get 6 discrete AC3 channels on the SDI
 - ➔ Simultaneous decoding of AAC-LC and AC3 audios is not possible.
-

4.3 MPEG AV Synchronization

MPEG transport streams normally contain information about the encoder clock system in order to genlock the decoder to the incoming signal and avoid buffer underrun or overflows. Moreover, the audio and video streams contain time stamps (PTS) in order to re-synchronize the stream at the output.

Should synchronization be a problem (PCR jitter, bad PTS), the MPEG clock recover system can be manually forced to OFF. In such case, the system decoder clock is free run and frames are repeated or dropped to cope with buffer overflows or underflows (frame buffer mode).

Setting the clock recovery in the OFF mode is particularly useful when network jitter is important and the video sync or audio sync status of the IRD keeps blinking.

- ⊕ To change the clock recovery mode, go to the card menu into **Input Menu, CLOCK RECOVERY**
- ⊕ Refer to section 3.4.6 for iControl.

4.4 About V-CHIP & Rating Information

The video stream may already contain XDS advisory data. If XDS data is already present, it is left untouched. No V-CHIP is generated if no XDS data is present.

-
- ➔ Closed captioning data must be present in the MPEG video stream or XDS data will not be inserted at the output
-

4.5 Using the Up/Down/Cross Option

The Up/Down/Cross Option allows the user to re-scale the input signal to any supported output resolution. Possible conversions are:

- Down scaling from 1080i to 720p (same frame rate)
- Up scaling from 720p to 1080i (same frame rate)
- Down scaling to 525 or 625 depending on frame rate
- Up scaling from 525 or 625 to 720 or 1080i keeping same frame rate

In addition to resolution conversion, the option allows aspect ratio conversion to occur. The user can either manually select the desired conversion method or use the AFD from the source to automatically resize the picture. In manual mode, the following scaling options are available:

- **NONE:** No aspect ratio conversion done. Any 16:9 pictures will appear as anamorphic 16:9 if down converted to SD.
- **AUTO:** The scaling method is selected automatically. In this mode, the AFD flag is used along with the aspect ratio of the output to select the best method. If no AFD is present, the default AFD flag is used.
- **STRETCH:** Use this mode to stretch the picture vertically. This mode is useful when the input picture has the wrong aspect ratio.
- **CENTER CUT:** When converting from 16:9 to 4:3, use this to crop both sides of the picture and fill the entire screen while keeping the aspect ratio.
- **LETTER BOX:** Adds black curtains to the 16:9 picture for 4:3 monitors
- **PILLAR BOX:** Adds black bars to the 16:9 picture to properly display 4:3 images on 16:9 monitors.

-
- ➔ Some modes may not apply depending on the input signal and desired output format.
 - ➔ If the selected mode is not possible the result will be the same as if NONE was selected.
-

The AUTO mode will use the input AFD to automatically choose the best rescaling method. The decisions follow the CEA-CEB16 recommendation for receivers/decoders.

4.6 About AFD processing

According to ATSC A/53 part 4, AFD and BAR data can be carried in MPEG signals. The AFD information and BAR data are extracted from the MPEG signal if present.

The user can configure the IRD to trigger on the AFD flags to automatically rescale the picture so that it is optimally displayed. Alternatively, the user can set the scaling mode to OFF and simply carry the AFD flags to the outputs for further processing. A card like the XVP-38xx from Grass Valley could then use the flag to rescale the picture properly.

In any case, the embedded AFD flag at the output follows any transformation that might have occurred. Therefore should the picture be rescaled, the embedded AFD reflects the actual status of the picture at the output. For example, an MPEG signal in full 16:9 (AFD code 8) down converted to SD 4:3 in letterbox will have the AFD flag 10 inserted to signal letterbox.

Alternatively to AFD, the user can select VLI or WSS (PAL only).

GUIDE TO INSTALLATION AND OPERATION

The charts below show the conversions that will be performed by the IRD-3811 when Active Format Descriptor (AFD) processing is activated by selecting AUTO using the *Aspect Ratio Scaling Mode* pulldown on the AFD tab of the Video Output panel. In the images shown in the chart:

BLACK  Indicates that this portion of the transmitted image will be black

GREY  indicates Protected Area, consisting of picture content which may be cropped for optimum display on screens with a different aspect ratio.

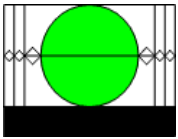
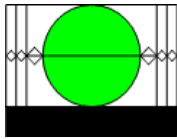
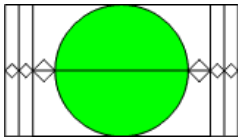
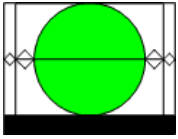
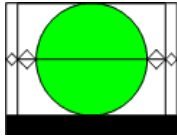
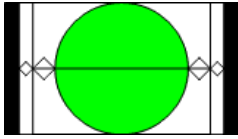
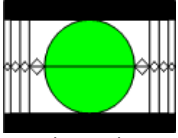
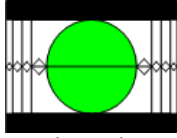
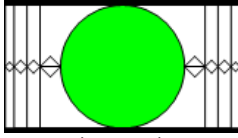
Input signal	4:3	Output signal	16:9
16:9 Letterbox (top) image in a 4:3 frame  (4:3_2)	16:9 Letterbox (top) image in a 4:3 frame  (4:3_2)	16:9 Full frame image in a 16:9 frame  (16:9_8)	
14:9 Letterbox (top) image in a 4:3 frame  (4:3_3)	14:9 Letterbox (top) image in a 4:3 frame  (4:3_3)	14:9 Pillar-box image in a 16:9 frame  (16:9_11)	
> 16:9 Letterbox (center) image in a 4:3 frame  (4:3_4)	> 16:9 Letterbox (center) image in a 4:3 frame  (4:3_4)	> 16:9 Letterbox (center) image in a 16:9 frame  (16:9_4)	

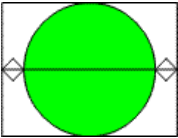
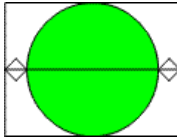
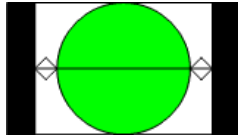
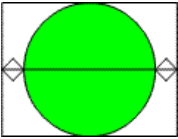
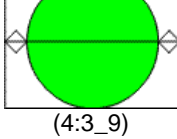
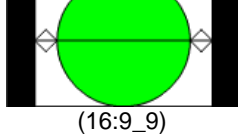
Input signal	4:3	Output signal	16:9
4:3 Full frame image in a 4:3 frame  (4:3_8)	4:3 Full frame image in a 4:3 frame  (4:3_8)	4:3 Pillar-box image in 16:9 frame  (16:9_9)	
4:3 Full frame image in a 4:3 frame (use preferred 4:3_8 code instead)  (4:3_9)	4:3 Full frame image in a 4:3 frame  (4:3_9)	4:3 Pillar-box image in 16:9 frame  (16:9_9)	

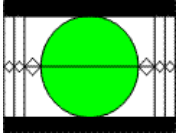
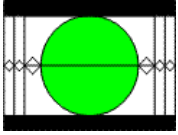
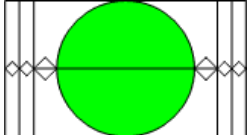
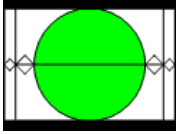
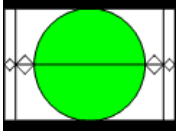
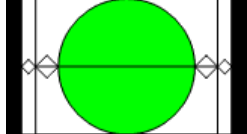
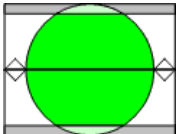
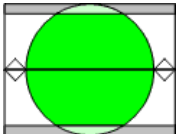
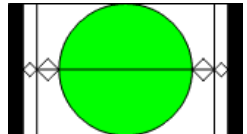
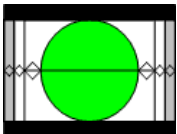
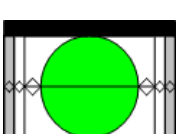
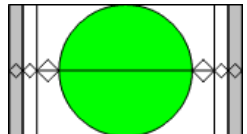
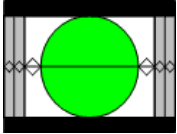
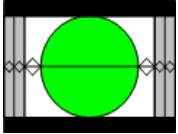
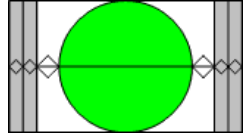
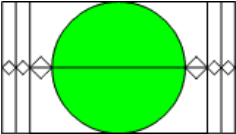
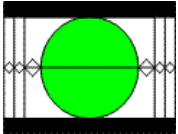
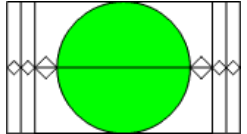
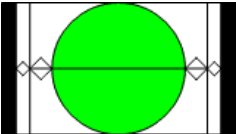
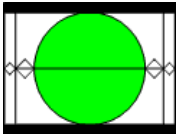
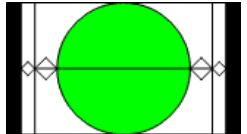
<p>16:9 Letterbox image in 4:3 frame</p>  <p>(4:3_10)</p>	<p>16:9 Letterbox image in 4:3 frame</p>  <p>(4:3_10)</p>	<p>16:9 Full frame image in a 16:9 frame</p>  <p>(16:9_8)</p>	
<p>14:9 Letterbox image in a 4:3 frame</p>  <p>(4:3_11)</p>	<p>14:9 Letterbox image in a 4:3 frame</p>  <p>(4:3_11)</p>	<p>14:9 Pillar-box image in a 16:9 frame</p>  <p>(16:9_11)</p>	
<p>4:3 Image shoot and protect 14:9 in a 4:3 frame</p>  <p>(4:3_13)</p>	<p>4:3 Image shoot and protect 14:9 in a 4:3 frame</p>  <p>(4:3_13)</p>	<p>14:9 Pillar-box image in a 16:9 frame</p>  <p>(16:9_11)</p>	
<p>16:9 Letterbox image shoot and protect 14:9 in a 4:3 frame</p>  <p>(4:3_14)</p>	<p>16:9 Letterbox image shoot and protect 14:9 in a 4:3 frame</p>  <p>(4:3_14)</p>	<p>16:9 Image shoot and protect 14:9 in a 16:9 frame</p>  <p>(16:9_14)</p>	
<p>16:9 Letterbox image shoot and protect 16:9 in a 4:3 frame</p>  <p>(4:3_15)</p>	<p>16:9 Letterbox image shoot and protect 16:9 in a 4:3 frame</p>  <p>(4:3_15)</p>	<p>16:9 Image shoot and protect 14:9 in a 16:9 frame</p>  <p>(16:9_15)</p>	
<p>Input signal</p>	<p>4:3</p>	<p>Output signal</p>	<p>16:9</p>
<p>16:9 Full frame image in a 16:9 frame (use preferred 16:9_8 flag instead)</p>  <p>(16:9_2)</p>	<p>16:9 Letterbox image in 4:3 frame</p>  <p>(4:3_10)</p>	<p>16:9 Full frame image in a 16:9 frame</p>  <p>(16:9_2)</p>	
<p>14:9 Pillar-box image in a 16:9 frame (use preferred 16:9_11 flag instead)</p>  <p>(16:9_3)</p>	<p>14:9 Letterbox image in a 4:3 frame</p>  <p>(4:3_11)</p>	<p>14:9 Pillar-box image in a 16:9 frame</p>  <p>(16:9_3)</p>	

GUIDE TO INSTALLATION AND OPERATION

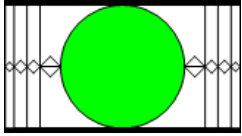
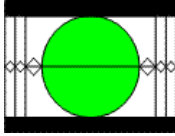
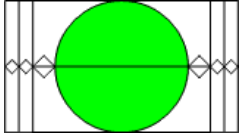
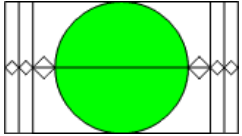
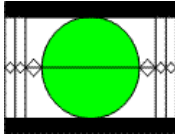
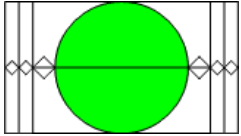
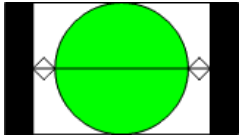
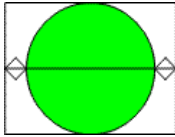
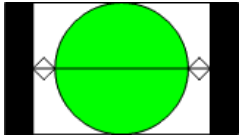
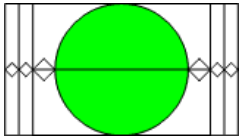
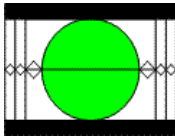
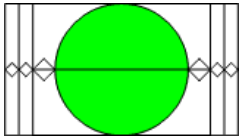
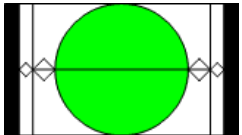
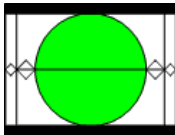
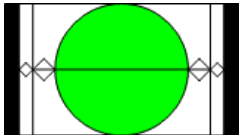
<p>> 16:9 Letterbox (center) image in a 16:9 frame</p>  <p>(16:9_4)</p>	<p>16:9 Letterbox image in 4:3 frame</p>  <p>(4:3_4)</p>	<p>16:9 Protected Full frame image in a 16:9 frame</p>  <p>(16:9_4)</p>
<p>16:9 Full frame image in a 16:9 frame</p>  <p>(16:9_8)</p>	<p>16:9 Letterbox image in 4:3 frame</p>  <p>(4:3_10) as shown here, or (4:3_8) as in box below</p>	<p>16:9 Full frame image in a 16:9 frame</p>  <p>(16:9_8)</p>
<p>4:3 Pillar-box image in 16:9 frame</p>  <p>(16:9_9)</p>	<p>4:3 Full frame image in a 4:3 frame</p>  <p>(4:3_8)</p>	<p>4:3 Pillar-box image in 16:9 frame</p>  <p>(16:9_9)</p>
<p>16:9 Protected Full frame image in a 16:9 frame</p>  <p>(16:9_10)</p>	<p>16:9 Letterbox image in 4:3 frame</p>  <p>(4:3_10)</p>	<p>16:9 Protected Full frame image in a 16:9 frame</p>  <p>(16:9_10)</p>
<p>14:9 Pillar-box image in a 16:9 frame</p>  <p>(16:9_11)</p>	<p>14:9 Letterbox image in a 4:3 frame</p>  <p>(4:3_11)</p>	<p>14:9 Pillar-box image in a 16:9 frame</p>  <p>(16:9_11)</p>

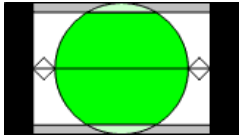
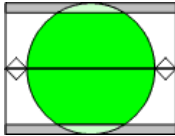
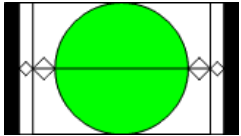
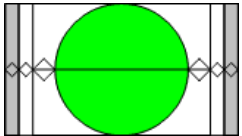
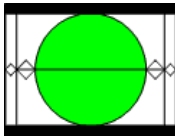
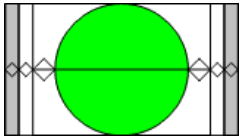
Input signal	4:3	Output signal	16:9
<p>4:3 Pillar-box image Shoot and protect 14:9 in a 16:9 frame</p>  <p>(16:9_13)</p>	<p>4:3 Image shoot and protect 14:9 in a 4:3 frame</p>  <p>(4:3_13)</p>	<p>14:9 Pillar-box image in a 16:9 frame</p>  <p>(16:9_11)</p>	
<p>16:9 Image shoot and protect 14:9 in a 16:9 frame</p>  <p>(16:9_14)</p>	<p>14:9 Letterbox image in a 4:3 frame</p>  <p>(4:3_11)</p>	<p>16:9 Image shoot and protect 14:9 in a 16:9 frame</p>  <p>(16:9_14)</p>	

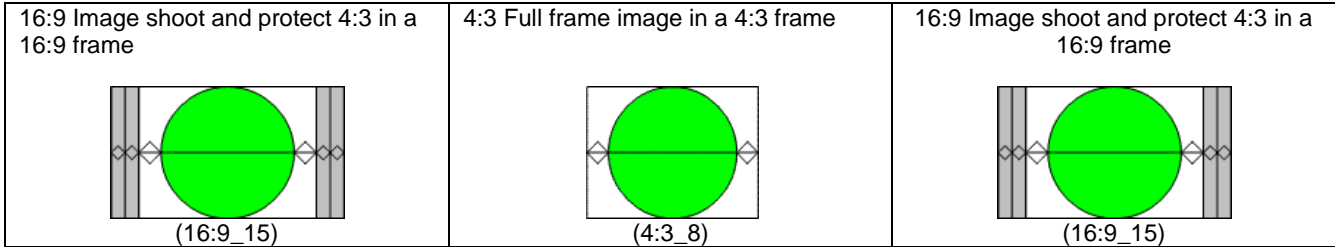

4.7 Using the TS Probing Option

Transport Stream (TS) probing is an option that can be purchased. The probing follows the TR 101 290 specifications with some exceptions. Note that iControl is necessary in order to visualize the errors. No probing report is available on the card's menu.

There are no special settings other than activating the display of errors on iControl. The probing is performed on the selected input only and PCR measurements are restricted to the selected program only.

-
- ➔ PCR Accuracy measurements are only valid with CBR streams as per TR 101 290
 - ➔ The probing is performed only on the first 128 PIDs
 - ➔ PCR measurements are only done on selected program
 - ➔ Only ATSC EIT-0 to 3 are probed
 - ➔ The Unreferenced PID list is updated every 10s. Therefore, a PID that is no longer present in the stream will disappear from the list after 10s.
 - ➔ PSIP probing is done on ATSC signals only
-

4.8 Using the video proxy streaming

The IRD is equipped with a low resolution H.264 video stream of the output for monitoring purposes. To use the proxy streaming, one needs iControl version 3.41 build 112 and up.

Depending on the video content, the user may experience momentary freezing of the picture due to bandwidth limitation. This may be more frequent when the frame rate selection is set to a fixed value.

-
- ➔ The streaming may not be able to match the frame rate requested. In such case, the video will freeze and restart when the data rate is below the allowed bandwidth.
-

5 Specifications

8VSB/QAM INPUT (IRD-3811-VQ only)

Quantity/connector:	One input with F-type connector, 75 ohm
Tuning range:	51 MHz-858 MHz
Input level:	-27 dBmV to +33 dBmV

QPSK/8PSK INPUT (IRD-3811-DVB-S2 only)

Quantity/connector:	One input with F-type connector, 75 ohm
Demodulation:	DVB-S (QPSK) ETSI EN 300 421 DVB-S2 (QPSK/8PSK) ETSI EN 302 307
Tuning range:	940 to 2150 MHz (in 0.5 MHz steps)
Symbol rate range:	DVB-S: 2 to 45 MSymbols/s
DVB-S2:	10 to 30 MSymbols/s
Input level:	-25 dBm to -65 dBm

ASI INPUT

Quantity/connector:	One input with BNC connector
Standards:	EN50083-9 (V2:3/98) DVB ASI
Data bit rate:	DVB ASI: Up to 80 Mbps
Mode:	Burst and byte supported
TS packet length:	188/204 byte packets
Return loss:	>15 dB up to 270 MHz

ASI OUTPUT

Quantity/connector:	One output with BNC connector
---------------------	-------------------------------

IP OUTPUT

Quantity/connector:	One Gigabit Ethernet with RJ45 connector IEEE 802.3
Standards:	Pro-MPEG Code of Practice 3 (CoP3)
Stream protocols:	IP/UDP, RTP and IGMPV3

VIDEO DECODER

Compatibility standard:	H.264/MPEG-4 AVC HP@L4.2 MPEG-2 at 4:2:0 compatible MP@HL <ul style="list-style-type: none">▪ 1080i59.94 / 50▪ 720p59.94 / 50▪ 525 / 625 ATSC A/53 Dual Dolby Digital pass-through
Bit rate:	Up to 25 Mbps

AUDIO DECODER

Standard:	MPEG-1 layer-II Dolby Digital (AC-3) audio 2.0 Optional Dolby Digital (AC-3) audio 5.1 AAC audio 2/0 and 1/0
Service/channels:	As per ATSC A/54A

VIDEO OUTPUTS

HD/SD SDI outputs:	Two outputs with BNC connectors
Signal:	SMPTE-259-C (270 Mbps)

SMPTE 292M (1.485, 1.485/1.001 Gbps)

Supported formats:

SD: 480i59.94, 576i50
 HD: SMPTE 274M: 1080i59.94, 1080i50
 HD: SMPTE 296M: 720p59.94, 720p50

Embedded audio:

SMPTE-299M, SMPTE-272M

Return loss:

>15 dB up to 1.5 GHz

Jitter:

<0.2 UI as per SMPTE-259M-C for SD output
 <0.2 UI as per SMPTE-292M for HD output

VIDEO AND TS METADATA

CC data extraction:

NTSC CC1 and CC2 as per EIA-608B

DTV CC:

EIA-608B compliant bytes of EIA-708B

CC embedding:

CC Embedding as per SMPTE-334M

Teletext:

WST/EIA 300 706

PSIP:

ATSC PSIP Standard A/65

REFERENCE INPUT

Reference input:

One input with BNC connector

Signal:

SMPTE 170M/SMPTE 318M/ITU 624-4/BUT 470-6 black burst
 SMPTE 274M/SMPTE 296M tri-level synch (black)

Return loss:

>35 dB up to 5.75 MHz

ELECTRICAL

Power:

25 W

6 Contact Us

Grass Valley Technical Support

For technical assistance, contact our international support center, at 1-800-547-8949 (US and Canada) or +1 530 478 4148.

To obtain a local phone number for the support center nearest you, please consult the *Contact Us* section of Grass Valley's website (www.grassvalley.com).

An online form for e-mail contact is also available from the website.

Corporate Head Office

Grass Valley
3499 Douglas-B.-Floreani
St-Laurent, Quebec H4S 2C6
Canada

Telephone: +1 514 333 1772

Fax: +1 514 333 9828

www.grassvalley.com

ANNEX 1 – Local Control Panel User Interface

IRD-3811

LEV 1	LEV 2	LEV 3	LEV 4	Settings
<p>CARD STATUS</p> <p>(the items in this part of the menu are for information only, and will cycle through the display if the user does not use the control panel buttons)</p>	<p>DEVICE STATUS</p> <p>SELECTED INPUT</p> <p>TUNER STATUS</p> <p>TS TYPE</p> <p>OUTPUT FORMAT</p> <p>REFERENCE STATUS*</p> <p>SELECTED SERVICE</p> <p>SERVICE FORMAT</p> <p>CLOSED CAPTION</p> <p>MAIN AUDIO</p> <p>SECONDARY AUDIO</p> <p>CARD IP ADDR</p>			<p>NO REAR, WRONG REAR, SYS OK</p> <p>DVB-ASI1, DVB-ASI2*, ETHERNET*, TUNER*</p> <p>SIGNAL</p> <p>CHANNEL:</p> <p>FREQ: xxxxMHz</p> <p>MOD: 8-VSB, e.g.</p> <p>BER: X.XXE+XX</p> <p>CHR: xxx dB</p> <p>NO SIGNAL, SIGNAL ERR, ATSC, DVB, ISO13818-1</p> <p><format> (<aspect ratio>)</p> <p>REF MISMATCH</p> <p>INTERNAL, EXTERNAL, URS</p> <p>1080i50,720p50,720p59.94,525,625,1080i59.94</p> <p>NUM xxxx(xxxxH)</p> <p>Name Unknown, <SERVICE Name></p> <p>Video PID xxxxH</p> <p>Video MPEG2/H.264</p> <p>Aud1 PID xxxxH</p> <p>Aud2 PID xxxxH</p> <p>Encrypted, <video format> (<aspect ratio>)</p> <p>DTVCC, DTVCC & NTSC, NOT PRESENT</p> <p>NOT PRESENT, (UNSUPP.) <type> (xxCH)</p> <p>NOT PRESENT, (UNSUPP.) <type> (xxCH)</p> <p>xxx.xxx.xxx.xxx</p>
<p>ATSC PSIP STATUS</p> <p>(for cards with ATSC tuner only)</p> <p>(the items in this part of the menu are for information only, and will cycle through the display if the user does not use the control panel buttons)</p>	<p>PSIP STATUS</p> <p>CHANNEL NAME</p> <p>CHANNEL NUMBER</p> <p>MODULATION MODE</p> <p>SERVICE TYPE</p> <p>PSIP TSID</p> <p>ATSC DATE</p> <p>ATSC TIME</p>			
<p>DVB SI STATUS</p> <p>(for cards with DVB S2 tuner only)</p> <p>(the items in this part of the menu are for information only,</p>	<p>READY</p> <p>CHANNEL NAME</p> <p>CHANNEL NUMBER</p> <p>MODULATION MODE</p>			

GUIDE TO INSTALLATION AND OPERATION

and will cycle through the display if the user does not use the control panel buttons)	SERVICE TYPE			
USER PRESET	LOAD SAVE			USER 1 ,USER 2, USER 3, USER 4, USER 5 USER 1 ,USER 2, USER 3, USER 4, USER 5
INPUT MENU	INPUT SELECTION AUTO SWITCH DEL. SERV SELECT MODE SERVICE SELECT CLOCK RECOVERY	-	-	ASI/SSI1, ASI/SSI2, ETHERNET, <u>AUTO SELECT</u> 0, 1, 2, 3,4, <u>5</u> , ... 15 sec MANUAL, <u>AUTO</u> <service name> (PGM xxxxx) OFF, <u>FROM PCR</u>
RF MENU	SELECT CHANNEL AVAIL. CHANNELS AUTO-SCAN CHAN			
ETHERNET MENU	NETWORK SETTINGS PORT DIRECTION STREAM IP ADDR PORT NUMBER ENCAPSULATION FEC	DEFAULT IP ADDR DEFAULT MASK DEFAULT GATEWAY		xxx.xxx.xxx.xxx xxx.xxx.xxx.xxx xxx.xxx.xxx.xxx DISABLED, <u>INPUT*</u> , OUTPUT xxx.xxx.xxx.xxx xxxx <u>RTP</u> , UDP <u>OFF</u> , D=x L=x
VIDEO MENU	OUTPUT ON ERROR OUTPUT FORMAT AFD MODE DEFAULT AFD CODE ASP. RATIO MODE DISP. ASP. RATIO VIDEO PROC	- - - - - - Y OFFSET CONTRAST CHROMA GAIN HUE OFFSET	- - - - - -	<u>Freeze</u> , Black <u>As Input</u> , 1080i, 720p, SD <u>AUTO_FORCED</u> numbers from 8 to 15 NONE, <u>AUTO_STRETCH</u> , CENTER CUT, LETTERBOX, PILLAR BOX <u>4:3</u> , 16:9
AUDIO MENU	PRIMARY AUDIO SECONDARY AUDIO DOLBY METADATA	SOURCE PID MODE DOWNMIX MODE SOURCE PID MODE DOWNMIX MODE INSERTION INSERTION LINE	- - -	List of avail PID in hexadecimal & decimal DECODE, PASSTROUGH <u>OFF*</u> , LTRT, LORO List of avail PID in hexadecimal & decimal DECODE, PASSTROUGH <u>LTRT</u> , LORO <u>OFF</u> , ON <u>9</u> , 10, 11,, 20

	EMBEDDING AV SYNC OFFSET AC3 COMPRESSION AC3 DRC	MODE DIALNORM GENERATOR ACTIVATION AES 1 Source AES 2 Source AES 3 Source AES 4 Source	-	<u>AUTO</u> , GENERATION <u>VERRIDE</u> , PROGRAM 1, PROGRAM 2 <u>ROGRAM 1</u> , PROGRAM 2 <u>ON</u> , OFF L1/R1/AC3 1, C1/Lfe1, Ls1/Rs1, L2/R2 L1/R1/AC3 1, C1/Lfe1, Ls1/Rs1, L2/R2 L1/R1/AC3 1, C1/Lfe1, Ls1/Rs1, L2/R2 L1/R1/AC3 1, C1/Lfe1, Ls1/Rs1, L2/R2 0, 1, 2, 3,, 100 ms LINE MODE, RF MODE OFF, ON
OUTPUT MENU	HD/SD SDI OUTPUT	CLOSED CAP EMBED TELETEXT VCHIP MODE AFD/VLI/WSS INS. AFD LINE		OFF, <u>ON</u> OFF, <u>AUTO</u> <u>PASS</u> , REPLACE OFF, <u>AFD</u> , VLI/WSS <u>9</u> ,, 20
REFERENCE MENU*	SOURCE DELAY	- FRAME VERTICAL HORIZONTAL	- -	INPUT,EXTERNAL,URS-525,URS-625, <u>AUTO_SEL</u> <u>0</u> , 1, 2, 3 <u>0</u> , ...200 specified in ns or us up to one complete line
PROXY CONFIG	PROXY SIZE PROXY AUDIO CTRL PROXY AUDIO L CH PROXY AUDIO R CH			SMALL, MEDIUM ON, OFF <u>LEFT</u> , RIGHT, CENTER, LFE, SURR LEFT, SURR RIGHT, AUX LEFT, AUX RIGHT LEFT, <u>RIGHT</u> , CENTER, LFE, SURR LEFT, SURR RIGHT, AUX LEFT, AUX RIGHT
TEST				<u>OFF</u> , ON
ALARM MENU	NO TS INPUT NO VIDEO SIGNAL NO AUDIO SIGNAL	ALARM LEVEL ALARM REPORT ALARM LEVEL ALARM REPORT ALARM LEVEL		OFF, YELLOW, <u>RED</u> , FLASH RED <u>NONE</u> , GPI OFF, YELLOW, <u>RED</u> , FLASH RED <u>NONE</u> , GPI OFF, <u>YELLOW</u> , RED, FLASH RED

GUIDE TO INSTALLATION AND OPERATION

	NO REFERENCE	ALARM REPORT ALARM LEVEL		<u>NONE</u> , GPI OFF, YELLOW, <u>RED</u> , FLASH RED
	REF MISMATCH	ALARM REPORT ALARM LEVEL		<u>NONE</u> , GPI OFF, YELLOW, <u>RED</u> , FLASH RED
	PROGRAM SYNCHRO	ALARM REPORT ALARM LEVEL		<u>NONE</u> , GPI <u>OFF</u> , YELLOW, RED, FLASH RED
	TS LIMITS	ALARM REPORT ALARM LEVEL		<u>NONE</u> , GPI <u>OFF</u> , YELLOW, RED, FLASH RED
		ALARM REPORT		<u>NONE</u> , GPI
VERSION	IRD-38x1: xxxB;xxx			First number is firmware, second is PCB. B = BETA
SERIAL NUMBER				Gives the serial number of the card
OPTIONS	FRAME SYNC ON UP/DN./CROSS ON TS PROBE ON ETHERNET ON DOLBY 5.1 ON			(status ON or OFF is shown beside option name) (status ON or OFF is shown beside option name) (status ON or OFF is shown beside option name) (status ON or OFF is shown beside option name) (status ON or OFF is shown beside option name)
FACTORY DEFAULT	RESTORE			

ANNEX 2 – Dolby Metadata Profiles

The chart shows the metadata parameter values that are available as Profiles 1 through 4 in the Generator Configuration section of the Metadata / Dolby tab in the Video Output iControl panel. See page 21.

Metadata Parameter	Profiles			
	1	2	3	4
Dialogue Level	-27	-27	-27	-27
Channel Mode	3/2	3/1	2/0	1/0
LFE Channel	On	Off	Off	Off
DC Highpass Filter	On	On	On	On
Lowpass Filter	On	On	On	On
LFE Filter	On	Off	Off	Off
Surround Phase Shift	On	On	Off	Off
Surround 3 dB Attenuation	On	On	Off	Off
Line Mode Compression	Film Light	Film Light	Film Standard	Film Standard
RF Mode Compression	Film Standard	Film Standard	Film Standard	Speech
RF Overmodulation Protection	Off	Off	Off	On
Bitstream Mode	Complete Main	Complete Main	Complete Main	Complete Main
Center Mix Level	-3	-3	-3	N/A
Surround Mix Level	-3	-3	-3	N/A
Dolby Surround Mode	Off	Off	On	N/A
Copyright Bit	Yes	Yes	Yes	Yes
Original Bitstream	Yes	Yes	Yes	Yes
Audio Production Info	No	No	No	No
Mix Level	85 dB SPL	85 dB SPL	85 dB SPL	85 dB SPL
Room Type	Not Indicated	Not Indicated	Not Indicated	Not Indicated
Preferred Stereo Downmix	Lt/Rt	Lt/Rt	Not Indicated	Not Indicated
Lt/Rt Center Mix Level	-3	-3	-3	-3
Lt/Rt Surround Mix Level	-3	-3	-3	-3
Lo/Ro Center Mix Level	-3	-3	-3	-3
Lo/Ro Surround Mix Level	-3	-3	-3	-3
Dolby Surround EX Mode	Not Indicated	N/A	-3	-3
Converter Type	Standard	Standard	Standard	Standard
Data Rate	Not Indicated	Not Indicated	Not Indicated	Not Indicated