

8985FSP/FS

SD/HD FRAME SYNC/PROC AMP

Instruction Manual

SOFTWARE VERSION 1.3.0

071843102
SEPTEMBER 2008



Affiliate with the N.V. KEMA in The Netherlands

CERTIFICATE

Certificate Number: 510040.001

The Quality System of:

Grass Valley, Inc.

400 Providence Mine Road
Nevada City, CA 95945
United States

15655 SW Greystone Ct.
Beaverton, OR 97006
United States

10 Presidential Way
3rd Floor, Suite 300
Woburn, MA 01801
United States

Nederland B.V.
4800 RP BREDA
The Netherlands

Weierstadt, Germany
Brunnenweg 9
D-64331 Weierstadt
Germany

Rennes, France
Rue du Clos Courtel
Cesson-Sevigne, Cedex
France

Technopole Brest Iroise
CS 73808
29238 Brest Cedex 3
France

17 rue du Petit Albi-BP 8244
95801 Cergy Pontoise
Cergy, France

2300 South Decker Lake Blvd.
Salt Lake City, UT 84119
United States

7140 Baymeadows Way
Suite 101
Jacksonville, FL 32256
United States

Including its implementation, meets the requirements of the standard:

ISO 9001:2000

Scope:

The design, manufacture and support of video hardware and software products and related systems.

This Certificate is valid until: June 14, 2009
This Certificate is valid as of: August 30, 2006
Certified for the first time: June 14, 2000

H. Pierre Sallé
President
KEMA-Registered Quality

The method of operation for quality certification is defined in the KEMA General Terms And Conditions For Quality And Environmental Management Systems Certifications. Integral publication of this certificate is allowed.

KEMA-Registered Quality, Inc.
4377 County Line Road
Chalfont, PA 18914
Ph: (215)997-4519
Fax: (215)997-3809
CRT 001 073004

Accredited By:
ANAB



8985FSP/FS

SD/HD FRAME SYNC/PROC AMP

Instruction Manual



SOFTWARE VERSION 1.3.0

071843102
SEPTEMBER 2008

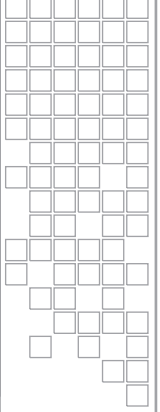
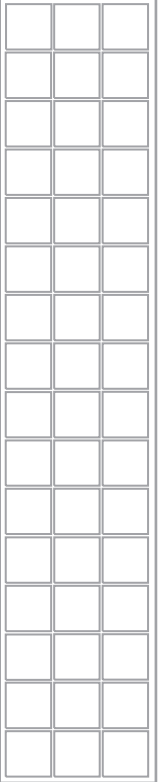
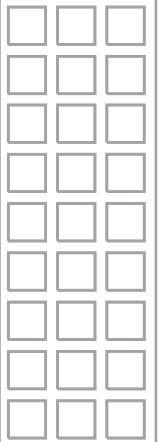

Contacting Grass Valley

International Support Centers	France 24 x 7	+800 8080 2020 or +33 1 48 25 20 20 +800 8080 2020 or +33 1 48 25 20 20	United States/Canada 24 x 7	+1 800 547 8949 or +1 530 478 4148
Local Support Centers (available during normal business hours)	Asia	Hong Kong, Taiwan, Korea, Macau: +852 2531 3058 Indian Subcontinent: +91 22 24933476 Southeast Asia/Malaysia: +603 7805 3884 Southeast Asia/Singapore: +65 6379 1313 China: +861 0660 159 450 Japan: +81 3 5484 6868		
		Australia and New Zealand: +61 1300 721 495	Central/South America: +55 11 5509 3443	
		Middle East: +971 4 299 64 40 Near East and Africa: +800 8080 2020 or +33 1 48 25 20 20		
	Europe	Belarus, Russia, Tadzikistan, Ukraine, Uzbekistan: +7 095 2580924 225 Switzerland: +41 1 487 80 02 S. Europe/Italy-Roma: +39 06 87 20 35 28 -Milan: +39 02 48 41 46 58 S. Europe/Spain: +34 91 512 03 50 Benelux/Belgium: +32 (0) 2 334 90 30 Benelux/Netherlands: +31 (0) 35 62 38 42 1 N. Europe: +45 45 96 88 70 Germany, Austria, Eastern Europe: +49 6150 104 444 UK, Ireland, Israel: +44 118 923 0499		

Copyright © Grass Valley. All rights reserved.

This product may be covered by one or more U.S. and foreign patents.

Grass Valley Web Site

The www.thomsongrassvalley.com web site offers the following:

Online User Documentation — Current versions of product catalogs, brochures, data sheets, ordering guides, planning guides, manuals, and release notes in .pdf format can be downloaded.

FAQ Database — Solutions to problems and troubleshooting efforts can be found by searching our Frequently Asked Questions (FAQ) database.

Software Downloads — Download software updates, drivers, and patches.



END-OF-LIFE PRODUCT RECYCLING NOTICE

Grass Valley's innovation and excellence in product design also extends to the programs we've established to manage the recycling of our products. Grass Valley has developed a comprehensive end-of-life product take back program for recycle or disposal of end-of-life products. Our program meets the requirements of the European Union's WEEE Directive, the United States Environmental Protection Agency, and U.S. state and local agencies.

Grass Valley's end-of-life product take back program assures proper disposal by use of Best Available Technology. This program accepts any Grass Valley branded equipment. Upon request, a Certificate of Recycling or a Certificate of Destruction, depending on the ultimate disposition of the product, can be sent to the requester.

Grass Valley will be responsible for all costs associated with recycling and disposal, including freight. However, you are responsible for the removal of the equipment from your facility and packing the equipment to make it ready for pickup.



For further information on the Grass Valley product take back system please contact Grass Valley at + 800 80 80 20 20 or +33 1 48 25 20 20 from most other countries. In the U.S. and Canada please call 800-547-8949 or 530-478-4148, and ask to be connected to the EH&S Department. Additional information concerning the program can be found at: www.thomsongrassvalley.com/environment



Contents

Preface	7
About This Manual.....	7
8985FSP/FS SD/HD Frame Sync/Proc Amp Modules	9
Introduction.....	9
Module Features.....	9
8985FSP Module.....	10
8985FS Module.....	10
Software Requirements.....	11
Installation.....	11
8985FSP/FS Module Placement For Genlock Timing.....	11
Module Installation.....	13
Module Installation Precautions.....	13
Rear Module Installation.....	15
Genlock Submodule Installation.....	16
Frame Bus Jumpering.....	17
Front Module Installation.....	18
Fiber Optics Submodule Installation.....	19
Cabling.....	20
Fiber Optic Cleaning Requirement.....	20
Video Inputs.....	21
Video Outputs.....	21
Genlock Loop.....	21
Auto Tracking Delay Outputs.....	21
Power Up.....	22
Operation Indicator LEDs.....	22
Configuration.....	24
Configuration Overview.....	24
Video Input Selection.....	24
System Configuration.....	24
800GEN-SM Reference Timing.....	24
Split Screen Control.....	25
Video Timing and Loss of Signal Controls.....	25
Color Correction.....	26
Video Processing Adjustments.....	26
User Settings.....	26
Video Outputs.....	26
Remote Configuration and Monitoring.....	27
Local/Remote Jumper.....	27
8900NET Module Information.....	27
Newton Control Panel Configuration.....	28
Web Browser Interface.....	29
Status Web Page.....	35
I/O Config Web Page.....	39

Video Input Web Page	41
System Config Web Page	42
Frame Sync Web Page	48
Color Correction Web Page	52
Video Proc Web Page	54
User Settings Web Page	56
Genlock Web Page	59
Video Out Web Page	63
Slot Config Web Page	64
Software Updating	66
Specifications	67
Status Monitoring Summary	70
External Frame Alarm	70
LED Reporting	71
Web Browser Interface	71
SNMP Reporting	71
Service	72
Power-Up Diagnostic Failure	72
Troubleshooting	72
Electronic Circuit Breaker	72
Module Repair	72
Contacting Grass Valley	72
Functional Description	73
Configuration Parameter Summary	75
Index	79

Preface

About This Manual

This manual describes the features of the 8985FSP and 8985FS module series and the corresponding rear modules in the GeckoFlex frame. As part of this family of modular products, it is subject to the Safety and Regulatory Compliance information described in the *GeckoFlex Frames Instruction Manual*. The 8985PRC module is covered in a separate manual.

This manual also has instructions for using the 8900GEN-SM submodule. For more detailed information, refer to the *8900GEN-SM GeckoFlex Genlock Submodule Instruction Manual* available online on the Thomson Grass Valley web site.

When using any of the fiber optic options, refer to the laser compliance information in the *GeckoFlex Frames Instruction Manual* for safety information.

All Modular documentation is available in PDF format at this link:

<http://www.thomsongrassvalley.com/docs/modular>

8985FSP/FS SD/HD Frame Sync/Proc Amp Modules

Introduction

This manual covers installation, configuration, and operation for the 8985FSP SD/HD Frame Sync Proc Amp and the 8985FS SD/HD Frame Sync modules.

Note Configuration of this module requires the presence of an 8900NET module (Net Card) in the GeckoFlex frame. 8900NET software version 4.3.0 is required for updating older version 8985FS/FSP modules to version 1.3.0 and is also recommended for operation.

Module Features

The two versions of the 8985 frame sync module provide various degrees of frame synchronization and video processing for environments utilizing SD and HD signals in both broadcast and ProAV applications. These environments require video signals to be synchronized with other video sources and processed for video quality.

The following features are available with this module series.

- Auto-sensing of input video standard,
- Two module set including a hot-swappable front and rear module.
- Up to ten audio or video modules in the same 2 RU GeckoFlex frame, including all 8900 Gecko Series modules.
- An optional Genlock submodule (8900GEN-SM) mounted on the 8985FSP/FS circuit board accepts an external reference (NTSC/PAL color black or Tri-Level Sync) and manages Local reference or two separate frame buses can be enabled when the submodule is installed on the modules in slots 1 and 3 of the frame.

- A fiber optic submodule option provides optical input/output interfaces for all models. One of three different types of single-mode fiber optic submodules can be used:
 - 1310NM-DTL – provides two optical outputs (TX 1 and TX 2)
 - 1310NM-DRL – provides two optical inputs (RX 1 and RX 2).
 - 1310NM-TRL – provides one optical input (RX 2) and one optical output (TX 1).
- Supports both HD or SD formats and passes embedded audio present in the incoming video stream.
- Split screen mode allows the input to be compared to the processed output.
- SNMP and product health monitoring is supported through the 8900NET module with applications such as NetCentral.
- Software updating using the NetConfig Networking application.

8985FSP Module

The 8985FSP provides the full spectrum of frame synchronization and video processing with the following list of features:

- Frame Sync (Genlock submodule required).
- Full-featured video processing amplifier allows component level (Y, Cr, Cb) adjustments of video gain and offset, plus phase control (hue), and color saturation adjustment.
- Also clip controls in the video processor for setting percentage of black and white clipping on the luminance channel and white clipping on the C channel.
- Color correction controls adjust RGB gain and offset and gamma correction.
- Two auto-tracking outputs to allow synchronization of audio modules to the Genlock reference.

8985FS Module

The 8985FS provides the same frame synchronization features as the full spectrum model without the processing amplifier or color correction.

Software Requirements

8985FSP software version 1.3.0 requires the presence of an 8900NET (Net Card) Network Interface module for configuration. The local front edge configuration controls for this module are not functional.

The latest version is recommended for optimum operation and must be at 4.3.0 for software updating. Check the software version of your 8900NET module by navigating to the Frame Status web page ([Figure 11 on page 30](#)) and noting the software version given below the frame graphic. Check the Thomson Grass Valley ftp server at this link for the latest 8900NET release:

<ftp://ftp.thomsongrassvalley.com/modular/8900/8900NET>

Installation

The 8985FSP consists of a front and rear module set that can only be installed into a GeckoFlex frame.

Installation of the 8985 module set is a process of:

1. Determining the placement of the 8985FSP or 8985FS module based on genlock timing configuration ([page 11](#)),
2. Placing the 8900GFR-R rear module in a rear frame slot ([page 15](#)),
3. Installing the Genlock submodule option on the front module ([page 16](#)),
4. Placing the front module in the corresponding front slot ([page 18](#)),
5. Installing the optional SFP Fiber Optic submodule ([page 19](#)), and
6. Cabling the signal ports ([page 20](#)).

All GeckoFlex front and rear modules can be inserted and removed from an GeckoFlex frame with power on.

8985FSP/FS Module Placement For Genlock Timing

Before installing the 8985FSP or FS module, you will first need to determine if and how you want to use a genlock reference or the available frame reference buses. The genlock timing from an 8900GEN-SM submodule can be utilized in several ways. Refer to the *8900GEN-SM GeckoFlex Genlock Instruction Manual* available online for a complete overview of using the genlock reference. This manual can be found in PDF format at the following URL on the Thomson Grass Valley web site:

www.thomsongrassvalley.com/docs/modular

In addition to the capability of providing a local external reference to this specific 8985FSP/FS module with an 8900GEN-SM submodule installed, slots 1 and 3 of the GeckoFlex frame have been specifically designed to distribute an independent frame bus reference transmitted from the 8900GEN-SM submodule mounted on an 8985FSP/FS module (or other GeckoFlex module with this capability) configured for this purpose.

The external reference connected to the corresponding Genlock Loop BNCs can be distributed to other modules in the frame that accept a genlock reference.

If another 8985FSP/FS module has already been configured and installed for frame bus distribution, you may configure this module's output timing to lock to the Frame Bus 1 or Frame Bus 2 reference from the other 8985FSP/FS module. In this case, the 8985FSP/FS does not require the use of an additional 8900GEN-SM submodule.

The use of the genlock reference is determined by the setting of the Output Timing on the System Config web page of the module and module placement in the frame and jumper configuration as summarized below.

- Local Reference – the 8985FSP/FS with an 8900GEN-SM submodule can have a local external reference connected to one of the corresponding Genlock Loop BNCs. This external timing reference will be fed to this specific 8985FSP module only.
- Frame Reference 1 or 2 – when an 8985FSP/FS with an 8900GEN-SM submodule is installed in Slot 1 and/or Slot 3, a frame timing bus can be enabled to distribute the external reference connected to the corresponding Genlock Loop BNCs on the rear module to all modules in the frame that can accept a genlock reference. Slot 1 provides Frame Bus 1 and Slot 3 provides Frame Bus 2.
- Input Video – when no 8900GEN-SM submodule is installed on the 8985FSP/FS, the Output Timing can be set to Input so the output timing will follow the input to the module.

Module Installation

There are ten front and rear cell locations in the 2 RU Gecko Flex frame (Figure 1) to accommodate either audio or analog and digital video module sets. The 8985 module set uses the 8900GFR-R rear module that can be installed in any one of the ten rear locations.

Figure 1. GeckoFlex Frame

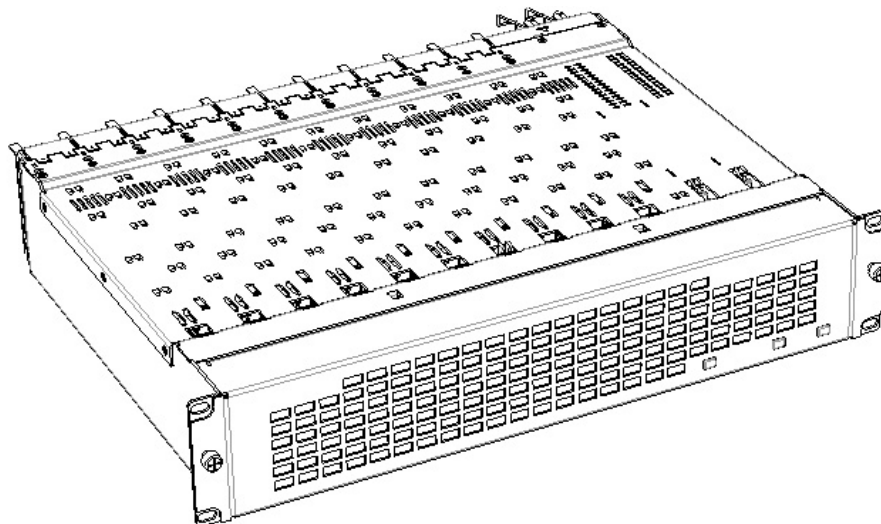

Module Installation Precautions

Please read and follow the precautions listed below before installing the front and rear modules and any fiber optic option submodules:

- Use standard anti-static procedures during installation. As modules can be installed or removed when the GeckoFlex frame is powered up, before removing the cover, please use an anti-static bracelet tied to a metal part of the frame.
- Install the rear module first, the 8900GEN-SM submodule on the front module (if used), the front module, then the optical submodule option (if used).
- When installing or removing a rear module, loosen or tighten the screws holding the retainer clips to the frame manually with the retainer clip tool provided inside the front cover of the frame or use a 2 mm (5/64") hex screwdriver. Please do not use an electric screwdriver.

Note On newer 751- version GeckoFlex frames, a Rear Retainer Clip removal tool and 2 extra retainer clips and screws for installing them are provided on the inside of the frame cover.

- Make every effort to leave the screws holding the retainer clips in place (do not remove them completely). They are very small and can easily drop into other equipment causing a shorting hazard. (Two turns of the screw should be enough to loosen the screws, 3 turns or more will remove it.)
- When installing a rear module, tighten the screws on the retainer clips just until snug. Do not apply more force than is necessary to seat the rear module. The retainer clip screw torque specification is 12 in-lb/1.35 nm as described in the **Mechanical** specifications in [Table 4 on page 67](#).
- If using a fiber optic submodule, handle it carefully, use anti-static precautions, and read the [Fiber Optic Cleaning Requirement on page 20](#) before cabling.

Rear Module Installation

To install the rear module, refer to [Figure 2](#) and the instructions below:

1. To remove a blank rear adapter cover (or a rear module already present), manually loosen the two screws holding each retainer clip on the rear adapter cover or rear module to the frame with the retainer clip tool provided inside the front cover of the frame (newer model frames only) or a 2 mm (5/64") hex screwdriver. Do not remove the screws.

Note To remove a rear module already installed, follow the same steps. It is helpful to first remove the front module so the rear can be pulled out more easily.

2. After loosening the retainer clip screws, pull up on each retainer and completely remove it, leaving the screws in place.
3. Remove the blank rear adapter cover by inserting needlenose pliers into the slots in the blank cover and pulling it off.
4. Insert the rear module into the empty slot, guiding it carefully.
5. Replace each retainer clip over the two screws on both sides of the module and push down to seat the retainer clip.
6. Tighten the two screws on each retainer clip just until they come into contact with the retainer clip then tighten about a 1/4 turn more (snug). Refer to the retainer clip screw torque specification ([Table 4 on page 67](#)). The retainer clips should not bend or be bowed.

Note All unused rear slots in a GeckoFlex frame should have a blank rear adapter cover installed.

Figure 2. Installing Rear Module (751- Version Frame Shown)

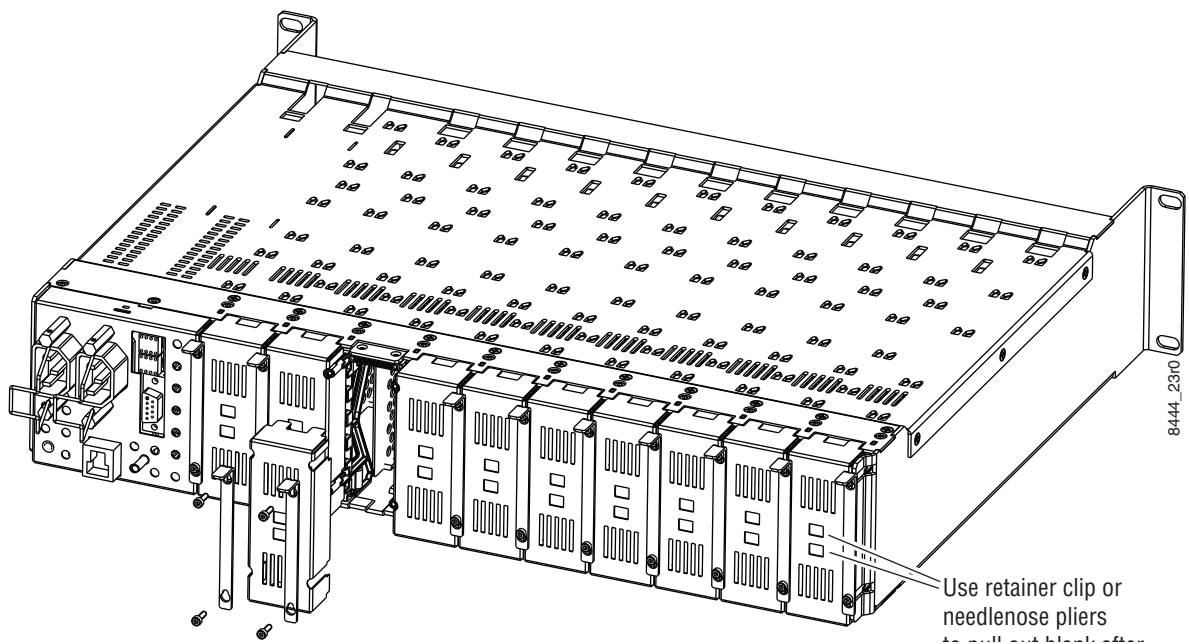

Genlock Submodule Installation

The Genlock submodule will ship in a separate package and must be installed on the front module.

To install a Genlock submodule, follow these steps:

1. Locate the Genlock connector J14, on the back side of the 8985FSP or FS circuit board (Figure 3).
2. Line up the connector on the submodule, J1, with J14 on the front module and snap the submodule into place making sure the holes in each circuit board line up.
3. To hold the submodule in place, attach the screw provided from the bottom of the front module to the standoff on the submodule circuit board.

Figure 3. Installing Genlock Submodule

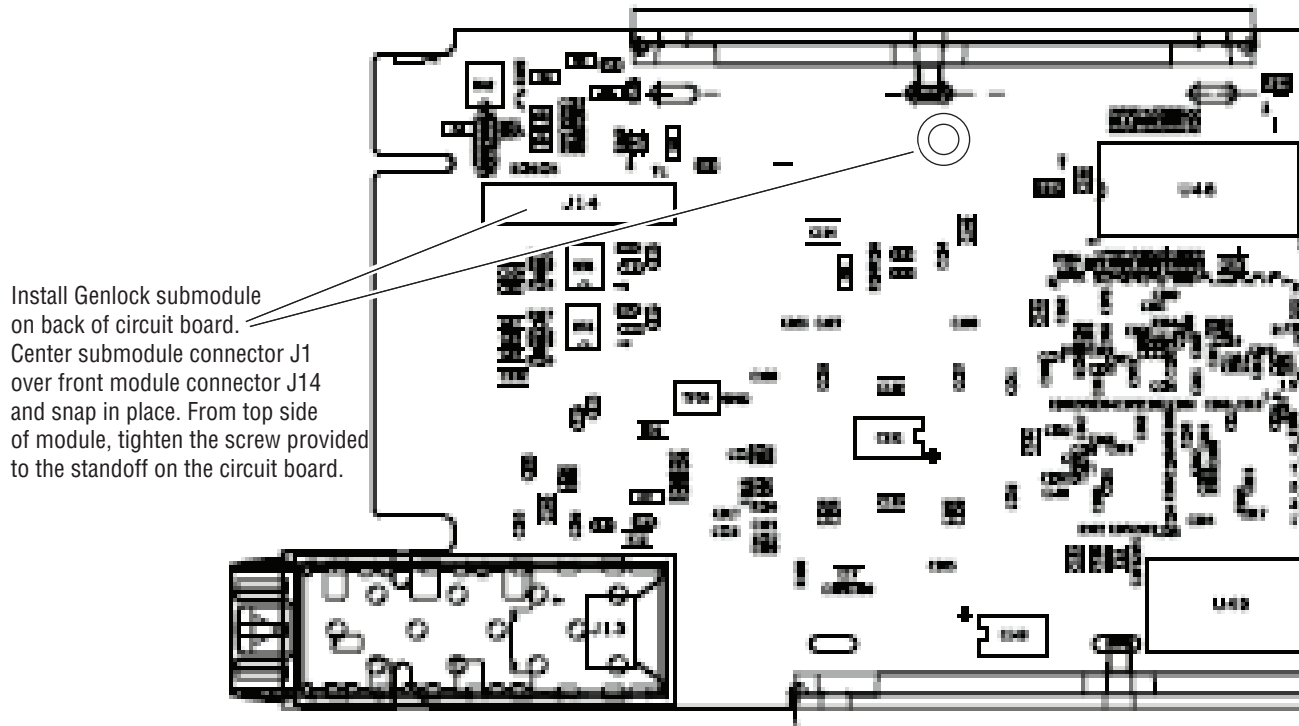

Frame Bus Jumpering

If you will be using this 8985 module to distribute reference Frame Bus 1 (slot 1) or Frame Bus 2 (slot 3), you must set a jumper on the front module circuit board for this purpose before installing the module (Figure 4).

- Frame Bus 1 – to transmit the reference connected to one of the Genlock Loop BNCs on the corresponding rear module on Frame Bus 1, set jumper J10 to **ENA** (pins 1-2). This module must be installed in slot 1 of the frame and configured on the Genlock web page (see [Genlock Web Page on page 59](#)) for **Auto** in the Drive Frame Reference Bus pulldown.
- Frame Bus 2 – to transmit the reference connected to one of the Genlock Loop BNCs on the corresponding rear module on Frame Bus 2, set jumper J13 to **ENA** (pins 1-2). This module must be installed in slot 3 of the frame and configured on the Genlock web page (see [Genlock Web Page on page 59](#)) for **Auto** in the Drive Frame Reference Bus pulldown.

Note Both jumpers may be enabled. The module in slot 1 will only read the status of jumper, J10. The module in slot 3 will only read the status of jumper, J13.

Figure 4. Setting Frame Bus Jumpers

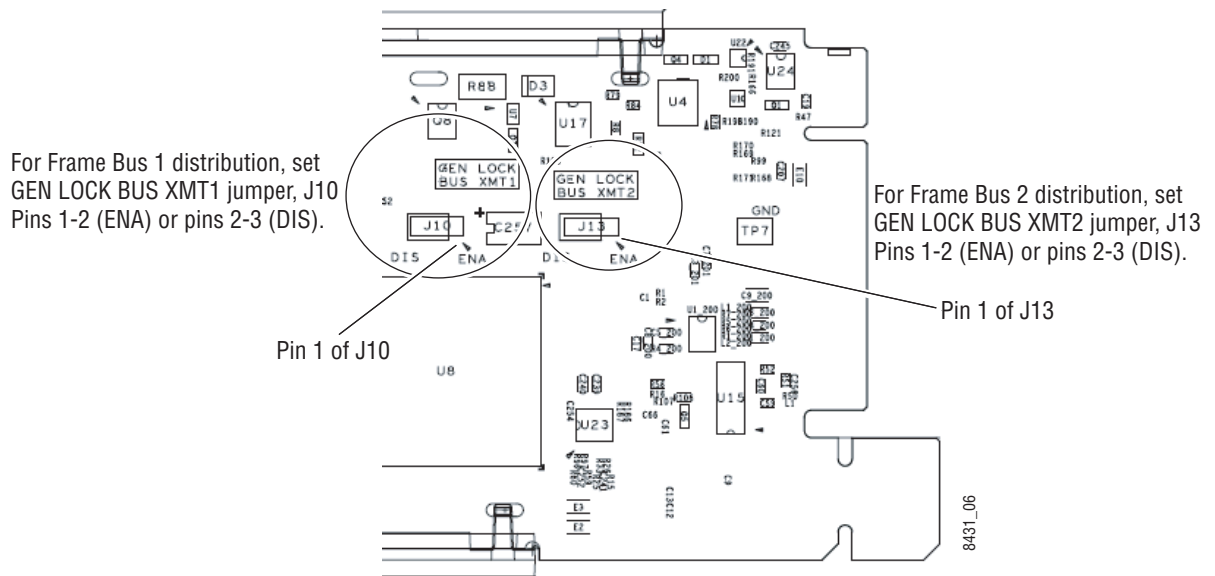

Front Module Installation

After installing the rear module and the Genlock submodule if required, and setting the Frame bus jumpering if required, install the front module as follows:

1. Remove the front cover of the frame if required.
2. Locate the corresponding front slot.
3. Insert the front module so that the plastic card guides on the module top and bottom edges go over the upper and lower raised rail guides on the right of the top and bottom of the slot ([Figure 5](#)).
4. Carefully slide the module into the rear connector.
5. Lock the front module ejector tab into the locking pin.

Note Before removing the front module, first remove the Fiber Optic submodule if present, from the rear module.

Figure 5. Front Module Installation

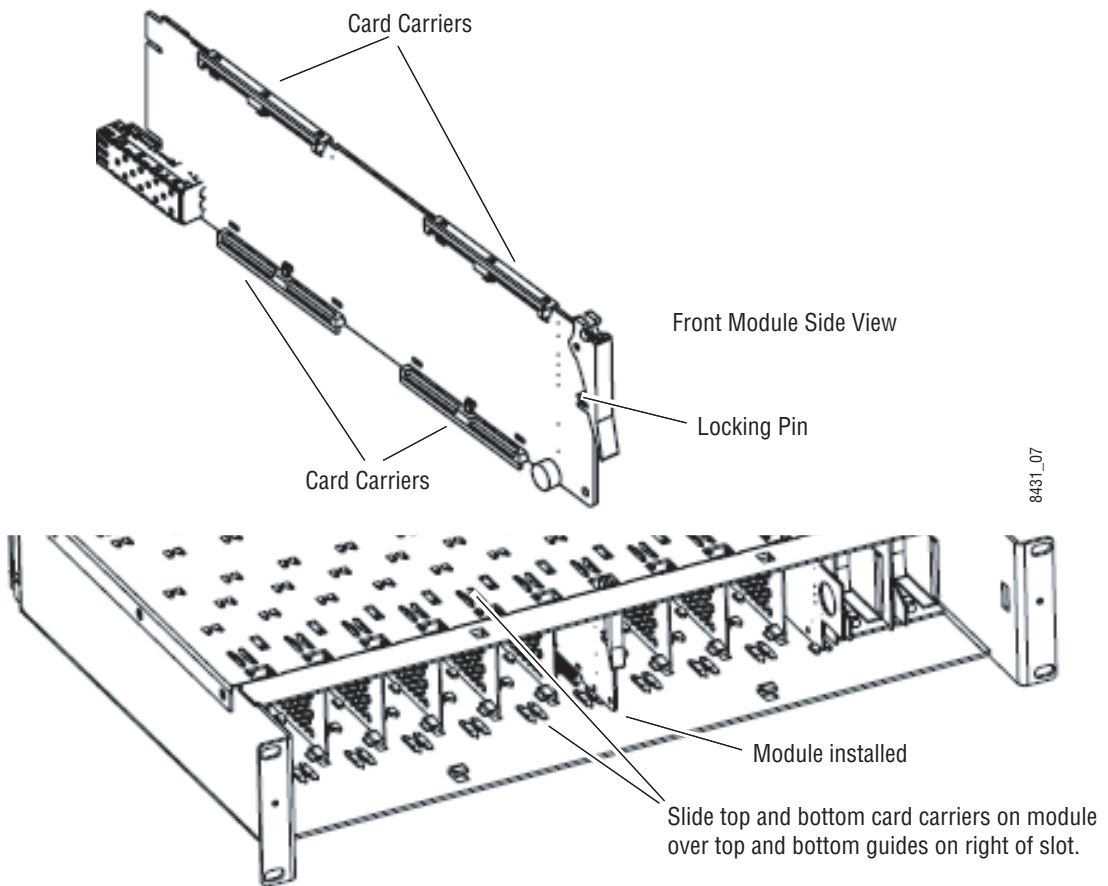

8431_07

Fiber Optics Submodule Installation

CAUTION The Fiber Optic submodule is static sensitive. Use static handling precautions when installing or removing the submodule.

After the front and rear modules have been installed, if required, install the SFP Fiber Optic submodule option into the rear module metal cage labeled FIBER (Figure 6). The SFP submodule is hot-pluggable and may be installed or removed with power applied to the module.

Note The submodule type is identified by name on the label or can be identified by the direction of the two arrow indicators on the label.

1. Slide the fiber optic device into the metal fiber cage with the label and handle to the right.
2. Push the device in as far as it will go without forcing it. It will not go completely into the cage.
3. Cable the fiber optic connectors according to the instructions given in [Video Inputs on page 21](#) and [Video Outputs on page 21](#).

Note Fiber inputs or outputs must be enabled in configuration.

Figure 6. Installing Fiber Optics Submodule

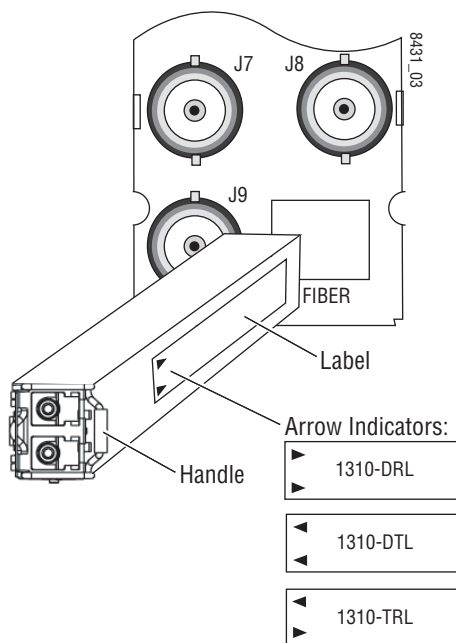

Removing an SFP Submodule

If you need to remove an SFP submodule, snap the handle out and pull the submodule slowly out of the metal cage.

Cabling

Cabling is done on the rear BNCs of the 8900GFR-R module illustrated in [Figure 7](#). Inputs and outputs are also illustrated on the I/O Config web page ([I/O Config Web Page on page 39](#)).

Fiber Optic Cleaning Requirement

Before making any fiber optic cable mating connections and after every de-mating cycle, use an industry standard fiber optic cleaning kit, including oil-free compressed air, to clean the fiber connectors and the connectorized fiber end faces. This helps ensure optimum performance of the fiber optic interface. Industry standard fiber optic cleaning kits can be purchased on the web and in electronics stores.

Figure 7. 8900GFR-R Rear Module

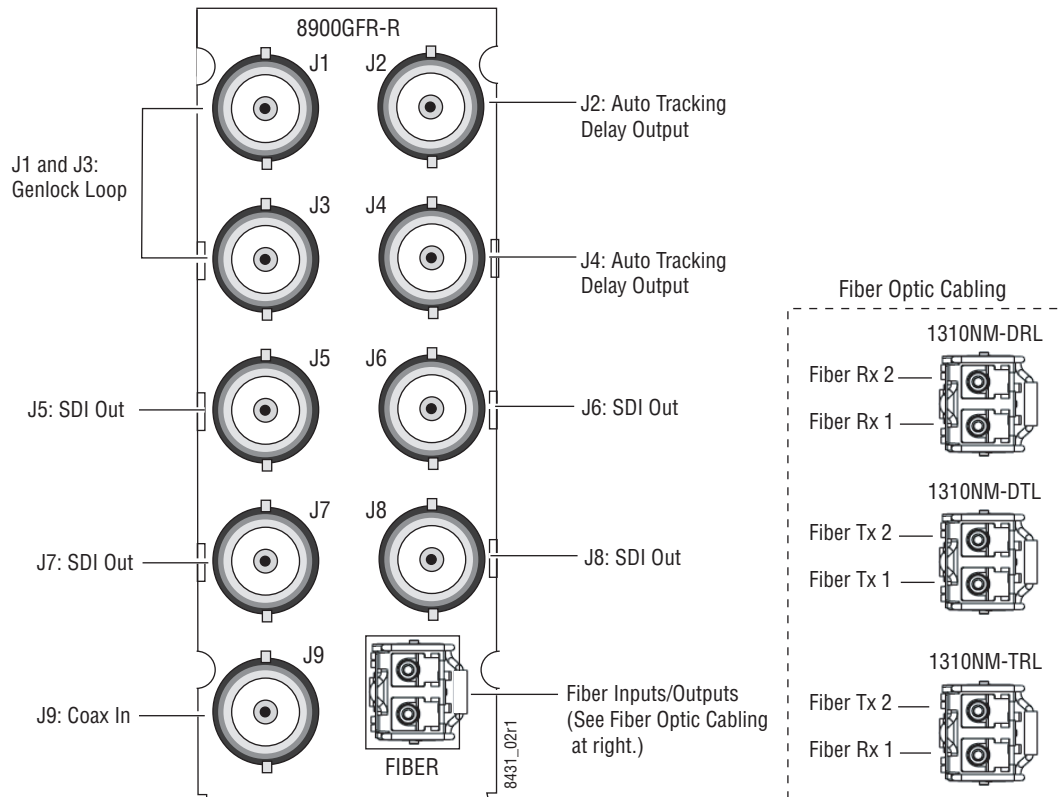

Video Inputs

Connect an HD or SD digital video signal to the Coax input at BNC J9, and/or to one or both of the fiber inputs at fiber connector J10 (depending on the type of fiber submodule installed).

Note Refer to [Table 2 on page 45](#) for important video input and external genlock reference input video frame rate compatibility information.

For fiber optic inputs, the 1310NM-DRL or 1310NM-TRL SFP optical submodule must be installed. Fiber inputs must be enabled with remote controls. Only one video input can be used at a time and must also be selected with remote controls.

Video Outputs

There are four electrical coax video outputs at BNCs J5, J6, J7, and J8.

If a 1310NM-TRL SFP optical submodule is installed, one fiber optic output is also available. If a 1310NM-DTL SFP optical submodule is installed, two fiber optic outputs are also available. Each fiber optic output must be enabled using local or remote controls. All coax and fiber optic outputs can be active at the same time.

Genlock Loop

BNCs J1 and J3 are looping inputs to support the optional Genlock submodule on the 8985FSP/FS module with an external genlock reference (NTSC/PAL color black or Tri-level sync). Refer to [Table 3 on page 61](#) for a table of compatible frame rates for installing the external genlock reference.

Connect an external reference to J1 or J2 and loop the other input to another device or terminate the unused input.

Auto Tracking Delay Outputs

BNCs J1 and J3 output an auto tracking delay signal that can be fed to audio modules to synchronize the audio to the Genlock reference from the 8985FSP/FS module.

Power Up

The front LED indicators and configuration switches are illustrated in [Figure 8](#). Upon power-up, the green PWR LED should light and the yellow CONF LED should illuminate for a few seconds for the duration of module initialization. The on-board configuration switches are not used on these modules.

Note When a media module is first plugged into a GeckoFlex frame, the 8900NET module (if present) may report a momentary fault. This will clear once the media module has booted up.

Operation Indicator LEDs

With factory default configuration and a valid input signal connected, the green PWR and (Figure 8) on the top side of the module front edge should illuminate (refer to [Table 1 on page 23](#) to see the possible operating indicator combinations).

Figure 8. Front Panel LED Indicators

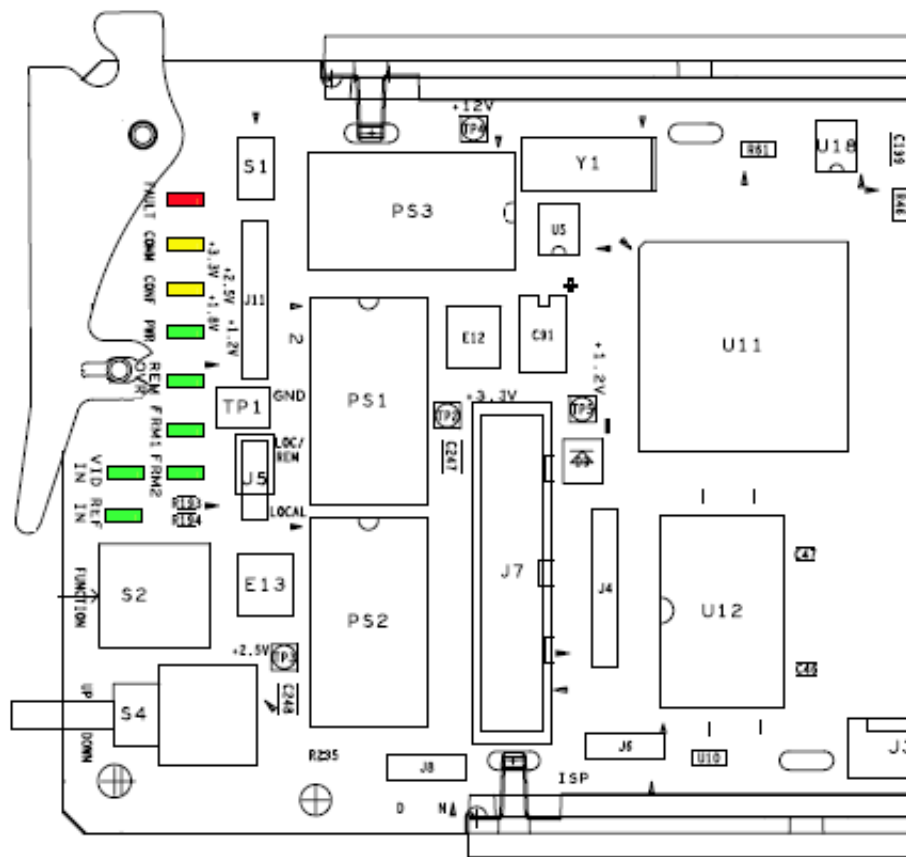

Table 1. Board Front Edge LED Names and Meaning

LED	Indication	Condition
FAULT (red)	Off	Normal operation.
	On continuously	Module has detected an internal fault.
	Flashing	Indicates a warning condition such as configuration problems or missing video. Check inputs and configuration settings.
COMM (yellow)	Off	No activity on frame communication bus.
	3 Quick Pulses	Locate Module command received by the module from a remote control system.
	Short flash	Activity present on the frame communication bus.
CONF (yellow)	Off	Module is in normal operating mode.
	On continuously	Module is initializing, changing operating modes or programming hardware.
	3 Quick Pulses	Locate Module command received by the module from a remote control system.
PWR (green)	Off	No power to module or module's DC/DC converter failed.
	On continuously	Normal operation, module is powered.
REM OVR (green)	Off	Not used on these modules, no local configuration controls.
	On	
FRM1 (green)	Off	Reference frame bus is disabled to frame on Genlock web page or no Genlock submodule is installed in slot 1.
	On	Reference frame bus is enabled on Genlock web page and Genlock submodule is installed in slot 1.
FRM2 (green)	Off	Reference frame bus is disabled to frame on Genlock web page or no Genlock submodule is installed in slot 3.
	On	Reference frame bus is enabled on Genlock web page and Genlock submodule is installed in slot 3.
VID IN (green)	Off	Indicates no valid input signal is being detected.
	On	Indicates a valid input signal is being detected.
REF IN (green)	On	Indicates no valid reference signal is being detected or signal is not locked.
	Off	Indicates a valid reference signal is present and locked.

Configuration

The 8985FSP/FS module can only be configured remotely using the 8900NET network interface GUI or a networked Newton control panel. An 8900NET (Net Card) module running software version 4.3.0 or later is recommended for optimum operation and required for software updating. (See [Software Requirements on page 11](#) for instructions for upgrading this software.)

Refer to the following sections for configuration instructions:

- Configuration Overview ([page 24](#))
- Remote Control and Monitoring ([page 27](#))
- Configuration Parameter Summary ([page 75](#))

Operation of these control types is explained in detail in their respective sections of this manual.

Configuration Overview

This section provides a brief overview of all parameters that can be configured on the 8985 module. Use this section in conjunction with the specific configuration method instructions for each configuration type. [Table 6 on page 75](#) provides a summary in table format of all parameters and their ranges, default values, and remote web page and Newton control panel function names and locations for setting each value.

Video Input Selection

Set the type of input connection from a coaxial electrical input or, if an optional SFP Fiber Optic submodule is installed, one of the fiber optic inputs.

System Configuration

System configuration is required for selection of the video input standard, enabling of the colorbars test signal, selection of the output timing source when the Frame Sync option is enabled, and the Reference Restore parameters can be set. A Split Screen mode for comparing the input to the output can also be enabled on the System Config web page.

8000GEN-SM Reference Timing

When an 8900GEN-SM submodule is installed as either a local reference to the host module or configured to output frame buses from host modules in slot 1 and slot 3, the genlock timing can be adjusted to match reference timing.

Split Screen Control

A Split Screen function can be enabled for comparing the unprocessed input to the processed output. This function is very useful when using the color correction or video processor controls. The Split Screen orientation can be set vertically or horizontally and can be adjusted for the amount of video to be displayed (10-90%). Interactive Split Screen controls are present on the 8995FSP System Config, Video Processing, and Color Correction web pages.

Video Timing and Loss of Signal Controls

On a 8985FSP/FS module with Frame Sync, the following timing adjustments are available:

- Horizontal Timing – adjusts the horizontal delay of the channel output in pixels
- Vertical Timing – adjusts vertical delay in line increments

Also available on the 8985FSP with Frame Sync are the following controls for setting the output condition when there is a loss of input signal:

- Auto Blue – when Auto Blue is enabled on a channel, the output will automatically freeze to a blue screen when the input signal is lost on the input.
- Auto Freeze – when Auto Freeze is enabled on a channel, the output will automatically freeze on the last valid field when the input signal is lost on the input.
- A Manual freeze can be performed at any time with the following two choices:
 - Frame
 - Field

Note A field freeze provides less resolution and no motion artifacts in the output. In frame mode, the resolution is higher since both fields are present, but the presentation of the two fields can cause motion artifacts.

- Multi-frame Delay – up to 6 frames of delay can be added to the signal as needed. When the H and V Timing controls are set to maximum, the total delay of the module can be 8 frames (when **Minimum Delay** is not selected)
- Minimum Delay Mode – the module can be set for minimum delay mode that bypasses portions of the frame sync memory to allow an absolute minimum amount of delay through the module. This mode is for special cases where the input is synchronous and its position with respect to the reference is well known.

Color Correction

On the 8985FSP module, color correction controls are provided for making RGB gain, offset and gamma correction adjustments. Each color channel can be adjusted separately or a total gain or total gamma can be applied to all channels.

Gamma controls brighten and darken the gray intensity of the signal. Raising the gamma above 1.0, brightens the gray intensity. Lowering the gamma below 1.0, darkens the gray intensity.

Video Processing Adjustments

On the 8985FSP module, component level (Y, Cr, Cb) adjustments are provided in the Video processor for video gain and offset, chroma gain, phase control (hue), and color saturation. Each color component can be adjusted separately or the total gain can be adjusted.

Y/C clipping controls are available in the Video Proc for adjusting the top (white) and bottom (black) luminance levels and the white clipping on chrominance channel of the output signal (C White Clip).

User Settings

Module default parameters and default signal names can be recalled at any time for the entire module or subsets of parameters such as the color corrector or video processor.

On the web pages, a **Defaults** button at the bottom of each applicable web page is available to return the parameters on that page to the factory defaults.

Save and load module configuration to/from a file are also provided on the web pages.

Video Outputs

When there is a 1310NM-DTL (2 outputs) or 1310NM-TRL (1 output) fiber optic submodule installed, one or both fiber outputs must be enabled for operation.

Remote Configuration and Monitoring

8985FSP and FS module configuration and monitoring must be performed using a web browser GUI interface or a networked Newton Control Panel when the 8900NET Network Interface module is present in the GeckoFlex frame. Each of these interfaces is described below.

Note The local configuration switches are present but not active on this module.

Local/Remote Jumper

The on-board jumper Local/Remote jumper, J5, must be set for local and remote operation (LOC/REM position, pins 2-3) or to lock out remote control (LOCAL position, pins 1-2).

Figure 9. Module Configuration Switches and LEDs

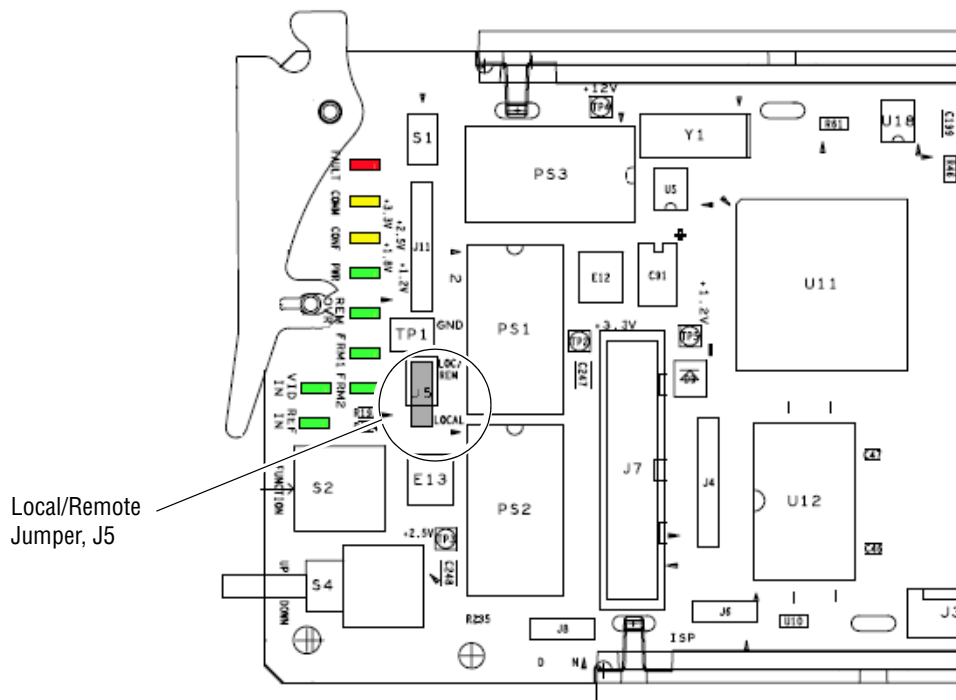

8900NET Module Information

Refer to the *8900NET Network Interface Module Instruction Manual* for information on the 8900NET Network Interface module and setting up and operating the GeckoFlex frame network.

Note The 8900NET module in the GeckoFlex frame must be running software version 4.3.0 or higher for proper remote control panel operation and software updating. Upgrade software and instructions for the 8900NET can be downloaded from the Thomson Grass Valley ftp site.

Newton Control Panel Configuration

A Newton Control Panel (hard and/or soft version) can be interfaced to the GeckoFlex frame over the local network. Refer to the documentation that accompanies the Newton Modular Control System for installation, configuration, and operation information.

Control panel access offers the following considerations for module configuration and monitoring:

- Ability to separate system level tasks from operation ones, minimizing the potential for on-air mistakes.
- Ability to group modular products—regardless of their physical locations—into logical groups (channels) that you can easily manipulate with user-configured knobs.
- Update software for applicable modules and assign frame and panel IP addresses with the NetConfig Networking application.
- Recommended for real-time control of module configuration parameters, providing the fastest response time.

Note Not all module functions are available with the control panel, such as E-MEM and factory default recalls. The available control panel controls for the 8985 module are listed in [Table 6 on page 75](#).

An example of the Newton Configurator is shown in [Figure 10](#).

Figure 10. Newton Configurator Example

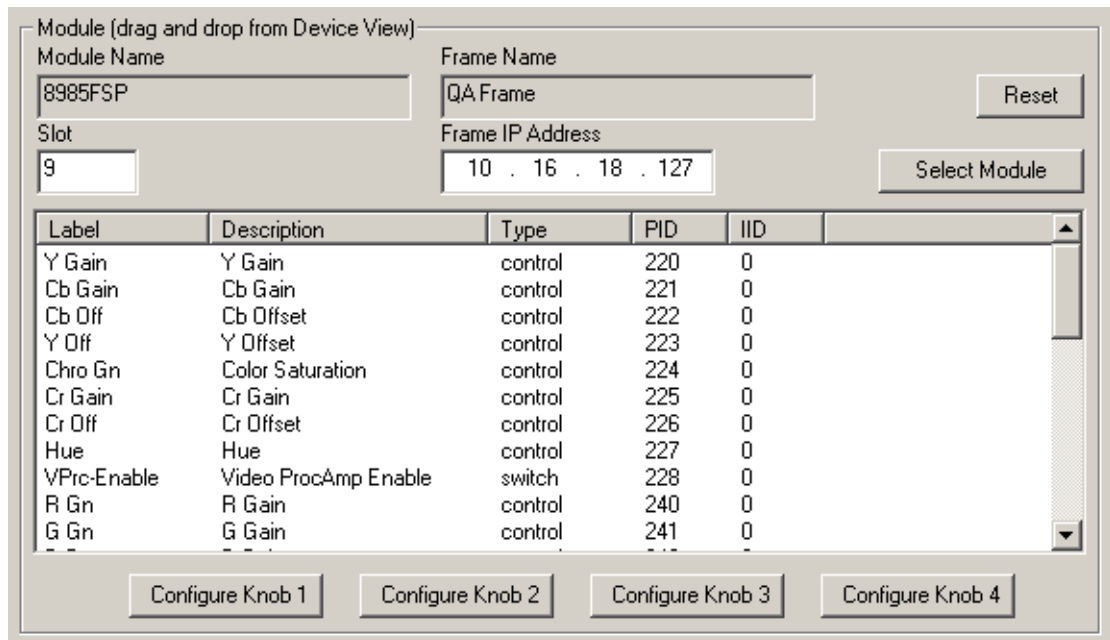

Web Browser Interface

The web browser interface provides a graphical representation of module configuration and monitoring.

Use of the web interface offers the following considerations:

- Provides complete access to all module status and configuration functions, including naming of inputs and outputs, factory parameter and name default recalls, E-MEM functions, slot configuration, and SNMP monitoring controls.
- Web access will require some normal network time delays for processing of information.
- Configuration parameter changes may require pressing **Apply** button or **Enter**, upload processing time, and a manual screen refresh to update the web page.
- Web interface recommended for setting up module signal and slot names, E-MEMS, and reporting status for SNMP and monitoring.

Refer to the Frame Status page shown in [Figure 11 on page 30](#). The modules can be addressed by clicking either on a specific module icon in the frame status display or on a module name or slot number in the link list on the left.

Note The physical appearance of the menu displays on the web pages shown in this manual represent the use of a particular platform, browser and version of 8900NET module software. They are provided for reference only. Displays will differ depending on the type of platform and browser you are using and the version of the 8900NET software installed in your system. This manual reflects Windows XP and an 8900NET module with software version 4.3.0.

For information on status and fault monitoring and reporting shown on the Status page, refer to [Status Monitoring Summary on page 70](#).

Figure 11. GeckoFlex Frame Status Page

The Links section lists the frame and its current modules. The selected link's Status page is first displayed and the sub-list of links for the selection is opened. The sub-list allows you to select a particular information page for the selected device.

Content display section displays the information page for the selected frame or module (frame slot icons are also active links).

Refresh button for manual update of page

Frame

- [Status](#)
- [Configuration](#)
- [Connections](#)
- [Frame Alarm Reporting](#)
- [LED Reporting](#)
- [SNMP Reporting](#)
- [Power Supply/Demand](#)
- [1 8995UDX](#)
- [2 Media Slot 2](#)
- [3 8995UDX+GEN](#)
- [4 Media Slot 4](#)
- [5 Media Slot 5](#)
- [6 Media Slot 6](#)
- [7 8985FS](#)
- [8 8985PRC](#)
- [9 8985FSP+GEN](#)
- [10 Media Slot 10](#)
- [11 8900NET](#)
- [12 Power Supply 1](#)
- [13 Power Supply 2](#)

Status

Model: 8900FFN Description: Module Frame
 Frame Location: not assigned
 Frame Health Alarm WARN Temperature Status PASS
 Power Status PASS

Module	Empty	Module	Empty	Empty	Empty	Module	Module	Module	Empty	Net Card	Empty	Power Supply
--------	-------	--------	-------	-------	-------	--------	--------	--------	-------	----------	-------	--------------

Front Cover No Cover

Properties

Vendor	Thomson, Grass Valley	Software Version	4.3.0
Media Slots	10	Network Config	Network configuration stored on frame

8431_08r3

Web Page Operations and Functional Elements

The following conventions and functional elements (shown at left) are used in GeckoFlex web page operations. (The examples shown throughout this manual represent 8900NET software version 4.3.0):

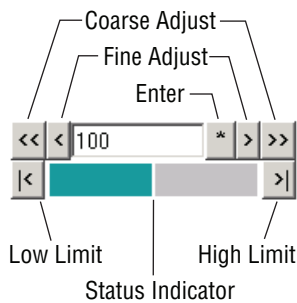
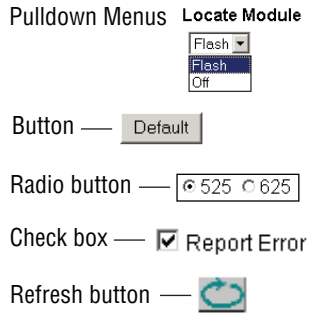

- Pull-down menus allow you to choose selections from a list.
- Clicking on a button performs an immediate action such as recall of defaults, clearing of states, learning configurations, and selecting all or none of a selection.
- Radio buttons are used to make a choice of one parameter in a group.
- Check boxes are used when a selection can be enabled or included in a group. Multiple check box selections or enables can be made for some parameters.
- A **Refresh** button (circular arrow) is provided at the top of each web page for manual refresh to view recently changed parameters.
- Each numerical adjustment control has a **Coarse** adjust button (left and right top double arrows) which increases or decreases the step value by a factor of 10. The **Fine** adjust button (left and right inside single arrows) increases or decreases the step value by 1.

To change a value, use the arrow button controls or enter a value into the number field and select the **Enter** button (*) or use the **Enter** key on your keyboard. The Status Indicator bar will follow the value selected.

Use the **Low** and **High Limit** buttons to go directly to the lowest and highest limits for the parameter.

- An entry field allows naming of various module functions such as input or output signals, asset tag, and slot identification.
- The **Status** LED icon indicates module status and is a link to the module Status web page.

LED colors indicate:

- Green = Pass – no problems detected
- Yellow = Configuration error warning
- Red = Fault condition detected

Web Page Headers

Each configuration web page has a Status and Identification Header as shown in [Figure 12](#) for the 8985FSP and [Figure 13](#) for the 8985FS module.

Figure 12. 8985FSP Status/ID Header

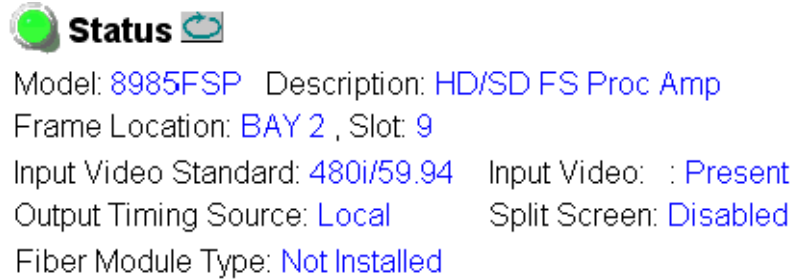
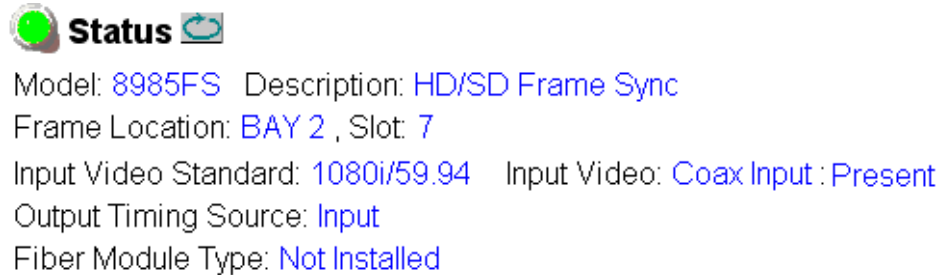
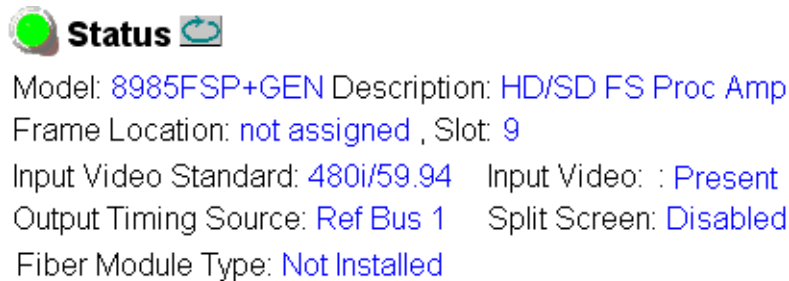

Figure 13. 8985FS Status /ID Header



When the 8985FSP or FS module has an 8900GEN Genlock submodule installed, the header shows the addition of the Genlock with + GEN ([Figure 14](#)).

Figure 14. 8995UDX + GEN Status Web Page



The header information on each web page includes the following:

- **Model** and **Description** are read-only generated by the module.
- **Frame Location** is defined on the 8900 Series GeckoFlex Frame Configuration web page.
- **Slot** number reports the module's location in the frame.
- **Input Video Standard** reports the input video type and rate selected on the System Config web page.
- **Input Video** reports the status of the video input to the module.
- **Output Timing Source** reports the output timing source (Frame Reference or Input) chosen on the System Config web page.
- **Split Screen** interactive status is reported (**Enabled** or **Disabled**) as set on the System Config, Color Correction, or Video Proc Amp web pages on the 8985FSP module. Not present on the 8985FS module.
- **Fiber Module Type** is reported in the Status, Video Input, and Video Output web page headers only.

Defaults

Web pages with configuration parameters each have a **Defaults** button at the bottom of the page to allow resetting of default parameters for only that page. Default values for all parameters are listed in [Table 6 on page 75](#).

Web Page Links

The web interface GUI provides the following links and web pages for the 8985FSP and FS modules ([Figure 15 on page 34](#)):

- **Status** – reports input and output signal status, frame bus communication status, module status and information, warnings and errors ([page 35](#)),
- **I/O Config** – shows a graphic representation of inputs and outputs to the module and allows naming of each input and enabling and disabling of signal reporting ([page 39](#)),
- **Video Input** – allows selection of the video input source and provides the status of all sources, including fiber optic submodule option inputs ([page 41](#)),
- **System Config** – select input video line standard, enable color bars test signal, set output timing source, set Reference Restore parameters, view phase difference graph, and controls for Split Screen functions ([page 42](#)),
- **Frame Sync** – provides horizontal and vertical timing, loss of signal controls, Minimum and Multi-Frame delay controls, and a Timing Status table showing total delay through the module ([page 48](#)),
- **Color Correction** – (8985FSP only) provides RGB gain, offset and gamma correction adjustments and controls for Split Screen functions ([page 52](#)),

- Video Proc – (8985FSP only) provides overall video processing and clip controls (White and black for luminance channel, white for C channel) for the HD or SD signal, and controls for Split Screen functions (page 54),
- User Settings – allows recalling of factory defaults for all module parameters or factory signal names, and provides a save/load configuration file function (page 56),
- Genlock – appears only on the 8985FSP and FS module links when the optional 8900GEN-SM submodule is installed on the module. This is also reflected in the web page header as shown in Figure 15 on page 34. Provides status reporting for the external genlock reference and controls for enabling the Genlock, matching the reference input to a selection standard, and setting reference signal delay (page 59),
- Video Out – enable and disable the fiber optic outputs when a fiber module is installed (page 63), and
- Slot Config – provides Locate Module, Slot Identification, and Slot Memory functions along with links to the 8900NET SNMP, LED Reporting, and Frame Alarm configuration web pages (page 64).

Figure 15. 8985FSP and FS Web Page Links

9 8985FSP+GEN	7 8985FS
Status	Status
I/O Config	I/O Config
Video Input	Video Input
System Config	System Config
Frame Sync	Frame Sync
Color Correction	User Settings
Video Proc	Video Out
User Settings	Slot Config
Genlock	
Video Out	
Slot Config	

A summary table of all module parameters including defaults, ranges, and Newton Control panel controls is given in Table 6 on page 75.

Status Web Page

Use
this
link

[9 8985FSP+GEN](#)
[Status](#)
[I/O Config](#)
[Video Input](#)
[System Config](#)
[Frame Sync](#)
[Color Correction](#)
[Video Proc](#)
[User Settings](#)
[Genlock](#)
[Video Out](#)

The Status web page ([Figure 16 on page 37](#) for the 8985FSP module and [Figure 17 on page 38](#) for the 8985FS module) reports information and status about the front media and rear modules and any submodules present (if applicable for the module) in both graphical (using color to indicate status) and textual formats. It also reports the status of the input and reference video signals to the module and submodules, and the Frame Bus status. Video and reference signal reporting can be enabled and disabled at the module level on the I/O Config web page ([page 39](#)).

In general, graphics and text colors used for status indication are the following:

- Green = Pass – signal or reference present, no problems detected.
- Red = Fault – fault condition.
- Yellow = Warning – signal is absent, has errors, or is mis-configured.
- Gray = Not monitored.



Note Always refresh the page first with the **Refresh** button at the top of the page (shown at left) to update the current status of the web page.

Web Page Header

The content of the web page header for the module is described in detail in [Web Page Header on page 35](#).

Module Physical Structure

Status is reported for the front, rear, and optional submodules as follows:

- Rear Module – the presence, name, and internal status of the rear module is reported in the graphic on the left. If the rear module is the wrong type or missing, the graphic will indicate the status by color and text within the graphic.
- Front Processing Module – the presence, name, and internal status of the front processing module is reported in the graphic on the right. The graphic will indicate the status of the front module by color and text within the graphic.
- Fiber Module – the optional fiber optic submodule status will be shown in the box on the front module graphic. When a fiber optic submodule is installed, the type will be reported in the top header and the Status text below the graphic on the right.
- Genlock Submodule – the status and presence of the optional Genlock submodule is reported in the front module graphic and the Status text below the graphic on the right.

Status is reported for each of the following video or reference signals:

- Video In – indicates the status of the video input to the module from the coax BNC, or one of two possible fiber optic inputs (depending on the type of fiber optic connector installed).
- Video Out – (gray) not monitored in this application.
- Genlock Ref In – indicates the status of the external genlock reference signal at BNCs J1 and J3 (Genlock Loop).
- Local Ref – indicates the status of the internally generated genlock reference signal from the 8900GEN-SM submodule to the front module.
- Frame Bus – indicates the status of the communication bus between the 8900NET module and the module.
- Ref 1 and Ref 2 In (From Frame) – the Ref 1 arrow will be present when Frame Bus 1 has been enabled on the module in slot 1. The Ref 2 arrow will be present when Frame Bus 2 has been enabled on the module in slot 3 of the frame.

Warning/Fault/Message Reporting

Faults, warnings, and informational messages from the module are displayed between the double bars below the graphic.

Note Many of these warnings are informational only and concern frame rate compatibility. Pay close attention to the frame rate compatibility explanations and tables in this manual.

Module Status

Module status for the front and rear modules (and any submodules if applicable) are reported as PASS, WARNING, ERROR, or EMPTY on the right at the bottom of the display.

Front Module Information

Information about the module, such as part number, serial number, hardware revision and software, firmware, and boot versions, and asset tag number (assigned on the [Slot Config Web Page on page 64](#)) are given on the left at the bottom of the display.

Figure 16. 8985FSP+GEN Status Web Page



Model: [8985FSP+GEN](#) Description: [HD/SD FS Proc Amp](#)
 Frame Location: [not assigned](#) , Slot: [9](#)
 Input Video Standard: [1080i/59.94](#) Input Video: [Coax Input : Present](#)
 Output Timing Source: [Input Video](#) Split Screen: [Disabled](#)
 Fiber Module Type: [Not Installed](#)

Module Physical Structure

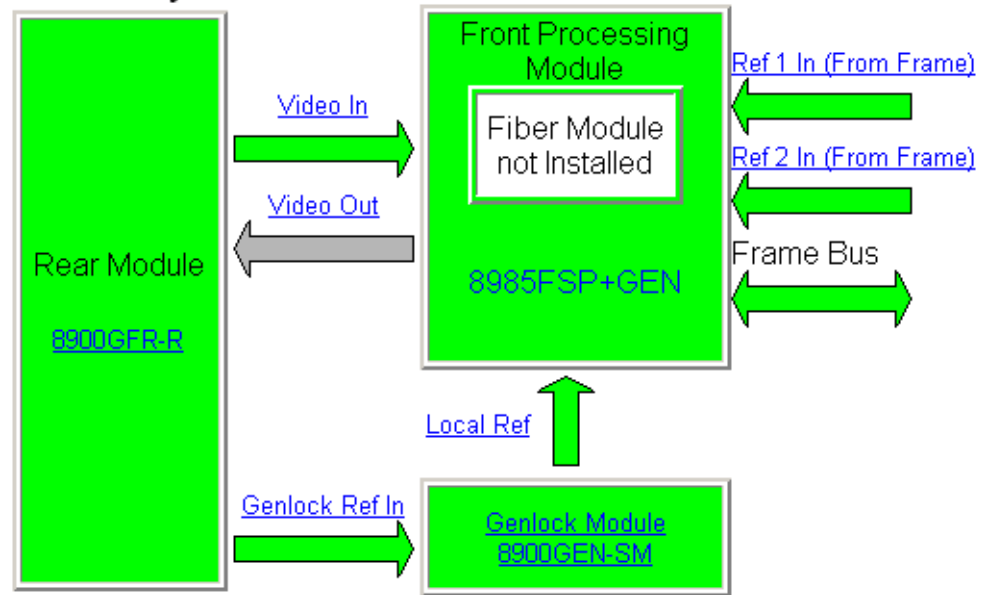

Warning messages

Status:

Front Module: [PASS](#)
 Rear Module: [PASS](#)
 Genlock Module: [PASS](#)
 Fiber Module: [EMPTY](#)

Front Module:

Part Number: [691-007902A](#)
 Serial Number: [KB07370013](#)
 Hardware Revision: [02A](#)
 Firmware Image 1 Version: [1.4.4](#)
 Firmware Image 2 Version: [inactive](#)
 Firmware Image 3 Version: [inactive](#)
 Firmware Image 4 Version: [inactive](#)
 Software Version: [1.3.0](#)
 Boot Version: [1.2.0](#)
 Asset Tag:

Figure 17. 8985FS Status Web Page



Model: [8985FS](#) Description: [HD/SD Frame Sync](#)
 Frame Location: [not assigned](#) , Slot: [7](#)
 Input Video Standard: [480i/59.94](#) Input Video: [Coax Input : Present](#)
 Output Timing Source: [Ref Bus 1](#) Split Screen: [Disabled](#)
 Fiber Module Type: [Not Installed](#)

Module Physical Structure

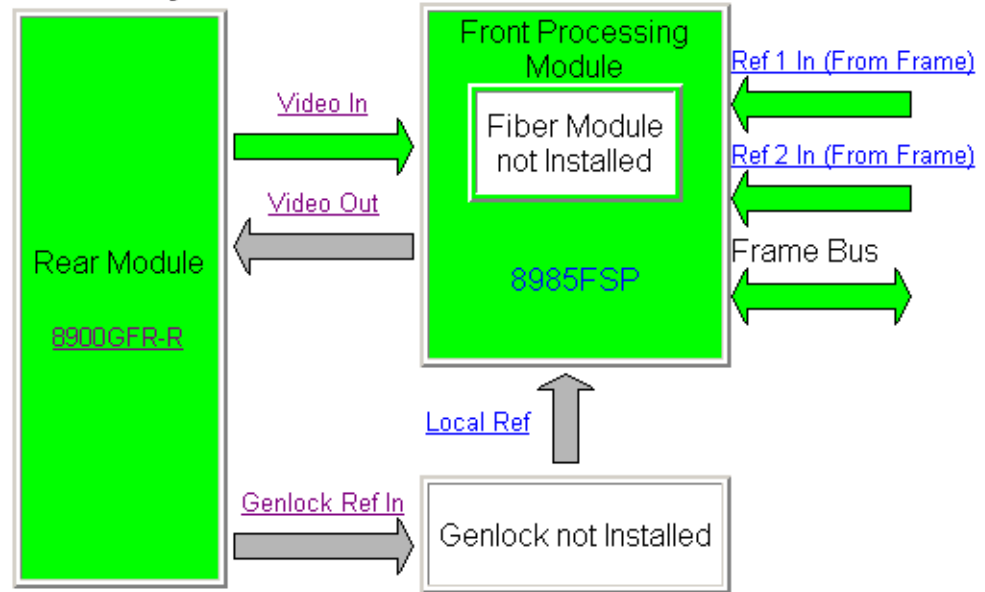

[Genlock Module is not installed](#)

Status:

Front Module: [PASS](#)
 Rear Module: [PASS](#)
 Genlock Module: [EMPTY](#)
 Fiber Module: [EMPTY](#)

Front Module:

Part Number: [691-0079-02A](#)
 Serial Number: [KB06520219](#)
 Hardware Revision: [02A](#)
 Firmware Image 1 Version: [inactive](#)
 Firmware Image 2 Version: [1.4.5](#)
 Firmware Image 3 Version: [inactive](#)
 Firmware Image 4 Version: [inactive](#)
 Software Version: [1.3.0](#)
 Boot Version: [1.2.0](#)
 Asset Tag:

I/O Config Web Page

Use
this
link

- [9 8985FSP+GEN](#)
- [Status](#)
- [I/O Config](#)
- [Video Input](#)
- [System Config](#)
- [Frame Sync](#)
- [Color Correction](#)
- [Video Proc](#)
- [User Settings](#)
- [Genlock](#)
- [Video Out](#)

Use the I/O Config web page ([Figure 18 on page 40](#)) for the following:

Rear Connectors

All of the input and output connectors on the corresponding 8985FSP rear module are illustrated on the I/O Config web page. The inputs can be configured with the following controls:

- **Signal Naming** – type the desired input name (up to 11 characters) into the corresponding boxes for each input. The status of each input is indicated by the color of the display.
- **Reporting Enabling** – status reporting of each input type can be enabled or disabled by selecting or deselecting the corresponding checkbox in the **Reporting Enabled** column for each input type. You may disable reporting for inputs not being used if desired to avoid error messages. The **Reporting Enabled** column is also used when an SNMP monitoring application such as NetCentral is installed.

Refer to [Status Monitoring Summary on page 70](#) for a summary of the color coding and using an SNMP monitoring application.

Note Outputs are not monitored in this application.

Figure 18. 8985FSP I/O Config Web Page

I/O Config











Model: 8985FSP+GEN Description: HD/SD FS Proc Amp

Frame Location: BAY 2 , Slot: 9

Input Video Standard: 480i/59.94 Input Video: Coax Input : Present

Output Timing Source: Local Split Screen: Disabled

Rear Connections

Signal Names	Reporting Enabled						Reporting Enabled	Signal Names
Ref Input	<input checked="" type="checkbox"/>	Genlock Ref In Loop	J1			J2		Audio Tracking Delay
			J3			J4		Audio Tracking Delay
		Output	J5			J6		Output
		Output	J7			J8		Output
Coax Input	<input checked="" type="checkbox"/>	COAX Video Input	J9			Fiber	<input checked="" type="checkbox"/>	Fiber Video In/Out 2 Fiber 2
							<input checked="" type="checkbox"/>	Fiber Video In/Out 1 Fiber 1

Legend:



Video Input Web Page

- Use this link
- [9 8985FSP+GEN](#)
 - [Status](#)
 - [I/O Config](#)
 - [Video Input](#)
 - [System Config](#)
 - [Frame Sync](#)
 - [Color Correction](#)
 - [Video Proc](#)
 - [User Settings](#)
 - [Genlock](#)
 - [Video Out](#)
 - [Slot Config](#)

Use the Video Input web page (Figure 19) to select and monitor the video input source to the module with the following:

Video Input Selection

This section provides the following for the video input signal:

- **Select Input Video** – select the input source from the rear module from one of the following:
 - **Coax** – corresponds to BNC input J9.
 - **Fiber RX 1** – will be present when either the 1310NM-DRL or 1310NM-TRL submodule is installed, or
 - **Fiber RX 2** – will be present when the 1310NM-DRL submodule is installed.
- **Signal Name** – the signal name defined on the I/O Config web page will appear in each field.
- **Signal State** – this field reports the status of the selected input video signal as **Present**, **Not Present**, or **Not Supported** (no fiber submodule installed).

Note Only the selected input status is monitored by the module. The input must be selected to report the correct status. Do not switch inputs without first selecting the desired input and checking its status.

Figure 19. Video In Web Page



Model: [8985FSP+GEN](#) Description: [HD/SD FS Proc Amp](#)

Frame Location: [not assigned](#) , Slot: [9](#)

Input Video Standard: [1080i/59.94](#) Input Video: [Coax Input](#) : [Present](#)

Output Timing Source: [Input Video](#) Split Screen: [Disabled](#)

Fiber Module Type: [Not Installed](#)

Video Input Selection

	Select Input Video	Signal Name	Signal State
Coax	<input checked="" type="radio"/>	Coax Input	Present
Fiber RX1	<input type="radio"/>	Fiber 1	Not Supported
Fiber RX2	<input type="radio"/>	Fiber 2	Not Supported

[Defaults](#)

System Config Web Page

Use
this
link

- [9 8985FSP+GEN](#)
- [Status](#)
- [I/O Config](#)
- [Video Input](#)
- [System Config](#)
- [Frame Sync](#)
- [Color Correction](#)
- [Video Proc](#)
- [User Settings](#)
- [Genlock](#)
- [Video Out](#)
- [Slot Config](#)

Use the System Config web page ([Figure 23 on page 44](#)) to monitor and set the following system configuration parameters for the module:

Video I/O Configuration

- **Ref Input** – the reference input standard selected on the Genlock web page ([Genlock Web Page on page 59](#)) is reported in this read-only field.
- **Input Standard** – select the video input standard and frame rate selection from the Input Standard pulldown from the following choices:
 - Auto – module will auto-sense input type
 - 480i– (SD 59.94)
 - 576i–(SD 50)
 - 720p–(HD 59.94)
 - 1080i–(HD 59.94)
 - 720p–(HD 50)
 - 1080i–(HD 50)
 - 1080p–(HD 24)
 - 1080sf–(HD 24)

Note The input video standard must be set to the same frame rate (or compatible frame rate as listed in [Table 2 on page 45](#)) as the reference input when the input video is associated with the reference input in the Output Timing controls for proper genlocking.

When a new selection is made in the **Inputs Standards** pulldown, a Changes Pending message will appear ([Figure 20](#)). Click the **Apply Settings** button to make the change.

Figure 20. Changes Pending Message

Changes Pending: Click 'Apply Settings' button to commit changes.

Video I/O Configuration	Test Output						
<table style="width: 100%; border-collapse: collapse;"> <tr> <td style="width: 50%; padding: 5px;">Ref Input</td> <td style="width: 50%; padding: 5px; text-align: center;">1080sf 24</td> </tr> <tr> <td style="padding: 5px;">Input Standard</td> <td style="padding: 5px;">720p–(HD 59.94) ▼</td> </tr> </table>	Ref Input	1080sf 24	Input Standard	720p–(HD 59.94) ▼	<table style="width: 100%; border-collapse: collapse;"> <tr> <td style="padding: 5px; text-align: center;">Colorbars</td> </tr> <tr> <td style="padding: 5px;"> <input type="checkbox"/> Enabled </td> </tr> </table>	Colorbars	<input type="checkbox"/> Enabled
Ref Input	1080sf 24						
Input Standard	720p–(HD 59.94) ▼						
Colorbars							
<input type="checkbox"/> Enabled							
<input type="button" value="Apply Settings"/> <input type="button" value="Cancel"/>							

While the module is re-initializing, a Waiting Page (Figure 21) will appear indicating the module is reconfiguring the input standard. Wait for the operation to complete. Press the **Refresh** button at the top of the page to update the page.

Note Pressing the **Defaults** button or changing the input type with an E-MEM recall may also cause the module to re-initialize.

Figure 21. Waiting Message

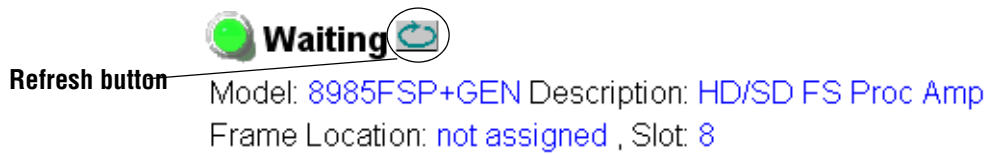

Please Standby ... reconfiguring

If the input standard selected is not present or not valid or not supported, a warning message will report the problem on the System Config web page as shown in Figure 22.

Figure 22. Input Standard Warning Message

Warning: Detected input (NONE-DETECTED) not supported .

Video I/O Configuration		Test Output
Ref Input	1080sf 24	Colorbars
Input Standard	<input type="text" value="Auto"/>	<input type="checkbox"/> Enabled

Figure 23. System Config Web Page

System Config

Model: 8985FSP+GEN Description: HD/SD FS Proc Amp
 Frame Location: not assigned , Slot: 9
 Input Video Standard: No Signal Input Video: Coax Input : Invalid Format
 Output Timing Source: Input Video

Video I/O Configuration

Ref Input	720p 59.94
Input Standard	720p—(HD 59.94) ▾

Test Output

Colorbars
<input type="checkbox"/> Enabled

Output Timing

Source Selection	Primary	Secondary	Status	GenLock
Local	<input type="radio"/>	<input type="radio"/>	Present	Locked
Ref Bus 1	<input type="radio"/>	<input type="radio"/>	Present	Locked
Ref Bus 2	<input type="radio"/>	<input type="radio"/>	Present	Locked
Input Video	<input checked="" type="radio"/>	<input checked="" type="radio"/>	Invalid Format	NA

Reference Restore

▾

Reference Switchback Delay (Seconds)

<< < 30.00 * > >>
 |< >|

Phase Difference

Primary - Secondary



Split Screen

Split	<input type="checkbox"/> Enabled
Orientation	Position (%)
<input checked="" type="radio"/> Vertical <input type="radio"/> Horizontal	<< < 50 * > >> < >

Table 2 is a video input standard to frame reference compatibility table to indicate what mismatch warnings will occur when the video input standard selected and the reference input are in a mismatch state.

Table 2. Input Video and Frame Reference Compatibility

Video Input Standard	Reference Detected	Mismatch Warning
480i	NTSC	None
	1080i 59.94 TLS	None
	720p 59.94	Yes ¹
576i	PAL	None
	1080i 50 TLS	None
	720p 50 TLS	Yes ¹
1080i 59.94	1080i 59.94 TLS	None
	NTSC	None
	720p 59.94 TLS	Yes ¹
720p 59.94	720p 59.94 TLS	None
	NTSC	None
	1080i 59.94 TLS	Yes ¹
1080i 50	1080i 50 TLS	None
	PAL	None
	720p 50 TLS	Yes ¹
720p 50	720p 50 TLS	None
	PAL	None
	1080i 50 TLS	Yes ¹
1080p 24	1080ip 24 TLS	None
	1080sf 24 TLS	None
	PAL	Yes ¹
	1080i 50 TLS	Yes ¹
	720p 50 TLS	Yes ¹
1080sf 24	1080isf 24 TLS	None
	1080p 24 TLS	None
	PAL	Yes ¹
	1080i 50 TLS	Yes ¹
	720p 50 TLS	Yes ¹

¹ A warning will be generated on both the Status and Genlock web pages when this condition occurs.

Test Output

An internally generated colorbars test signal may be enabled on the output of the module by checking the **Enabled** checkbox. Be sure to disable this output before going on-air.

Output Timing

Select the Primary and Secondary output timing source for the module as either **Local** (external reference from the 8900GEN-SM submodule mounted on this module), **Ref Bus 1** (8900GEN-SM submodule is mounted on module in slot 1 and jumpered for outputting a Ref 1 frame bus), **Ref Bus 2** (8900GEN-SM submodule is mounted on module in slot 3 and jumpered for outputting a Ref 2 frame bus), or **Input**, the reference is taken from the input video. The signal and genlock status of each reference source will be reported in the Status and Genlock columns.

When a Secondary reference source is selected that is different than the Primary, the module can be configured to switch automatically to the Secondary selected if the Primary is lost or becomes unlocked or invalid. If you do not want this action of switching to a secondary, set the Primary and Secondary sources to the same source or set the Switch to Primary control below to **Manual**.

Refer to [8000GEN-SM Reference Timing on page 24](#) for an overview of using the 8900GEN-SM submodule for reference timing. Also refer to the *8900GEN-SM Installation Manual* available online for complete details for using this submodule for timing applications.

Reference Restore

If the Primary source has failed and a Secondary source is selected and valid, the following controls allow you to set the module to switch back to the Primary automatically or manually and determine the amount of time before the Primary is restored.

- **Switch to Primary** – set this control to **Manual** if you wish to manually return to the Primary reference when it becomes valid or locked again or **Auto** to allow the module to switch back to the Primary reference.
- **Reference Switchback Delay** – when the control above is set for **Auto**, set the amount of time to allow between switching from the Secondary reference back to the restored Primary. The switchback time has a minimum recovery time of 30 seconds to assure that the Primary is locked and valid before the module switches back to this source.

Primary – Secondary Phase Difference

This graphic is provided to show the total phase difference between the Primary and Secondary reference signals. When the bar is green and remains in the area before the horizontal indicator, the two references are in a range where switching between the two will show no measurable disturbance in the output video (approximately 72 nS).

When the phase difference is larger than the recommended amount, the bar will indicate by showing a second red bar. This indicates that the phase difference is now such that switching between the two references will show a disturbance in the output video. This can be caused by a loss of one of the references or a mis-adjustment in the reference output delay of either reference. The total phase error shown in this graphic represents approximately 1 uS.

If the red bar appears, check the System Config page for the presence and lock status of both the Primary and Secondary references. If there is a timing difference, use the Genlock web page timing controls to bring the two references into the green bar range. Refer to the [Genlock Web Page on page 59](#).

Split Screen

Use a horizontal or vertical split screen to compare the unprocessed input video (top or right) to the processed output video (bottom or left). This control is duplicated and tied together with the Split Screen controls on the Color Correction and Video Proc web pages. Changes made on any one of the Split Screen controls will control all three screens.

- **Split Enable** – enable the split screen by checking the **Split Enabled** checkbox.
- **Orientation** – select the orientation of the split screen with the **Vertical** or **Horizontal** radio button.
- **Position** – use this control to set the amount of horizontal or vertical split (10 to 90%) of unprocessed video to appear on the screen.

Frame Sync Web Page

[9 8985FSP+GEN](#)

[Status](#)

[I/O Config](#)

[Video Input](#)

[System Config](#)

[Frame Sync](#)

[Color Correction](#)

[Video Proc](#)

[User Settings](#)

[Genlock](#)

[Video Out](#)

[Slot Config](#)

Use
this
link

The Frame Sync web page ([Figure 24 on page 50](#) for Local or Reference Bus reference and [Figure 25 on page 51](#) for Input reference) provides horizontal and vertical timing and loss of signal controls for the 8985FSP module.

Note The controls available on the Frame Sync page depend on the Output Timing Source selected on the System Config web page.

Timing Adjustment

When the Frame Sync option is present and the **Local** output timing source is selected, horizontal and vertical timing adjustments can be made on the output video as required relative to the external reference with the following controls

- **H Timing (Pixels)** – the horizontal timing can be adjusted in pixels relative to the external reference.
- **V Timing (Lines)** – the vertical timing can be adjusted in lines relative to the external reference.
- **Multi-Frame Delay** – this control allows you to add up to 6 frames of delay. When the H and V Timing controls are set to maximum, the total delay of the module will be 8 frames (when **Minimum Delay Mode** is not selected).

Minimum Delay Mode

A Minimum Delay Mode can be enabled to bypass portions of the frame sync memory to allow an absolute minimum amount of delay through the module. It is a special mode allowing the user to select a throughput delay of about 300 pixel periods when the input is synchronous and its position with respect to the reference is well known. To enable this mode, check the **Enabled** checkbox.

Note Delay can be added when in Minimum Delay Mode without causing video distortion up to one line short of a whole frame period of user delay. For normal delay operations, Minimum Delay mode should be disabled.

Loss of Signal Operation

Set the operation to be performed by the module upon loss of input signal when a Local external reference is present (**Auto Blue, Auto Freeze, or Pass**).

When there is no external reference (output timing set to Input), the module will default to pass the signal to the output.

Manual Freeze Mode

Select one of the radio buttons (**Frame** or **Field**) to perform a manual freeze on the output.

Timing Status

In the Timing Status table, **Total Video Delay** is reported through the module in numerical format in frames and in microseconds as shown in the example in [Figure 24 on page 50](#).

The **Delay Wrap Position** indicator will display with a blue bar, the fraction of the final frame of actual video delay through the frame sync. It will not indicate if multiple frames have been selected with the Multi-Frame Delay control.

For example, with 1080i video and Minimum Delay Mode not selected, if 600 lines plus 5 frames of delay is entered by the user, that actual delay through the module will be anywhere from about 6 to 7 frames depending on the following conditions:

- If the module is in Delay (Input-Timed) Mode, the delay through the module will be about 6.5 frames, and the Delay Wrap Position will be at about 50% of full scale.
- If the module is in Frame Sync (Genlock) Mode, the delay through the module will be about 6.5 frames if the input video has zero delay with respect to the genlock reference frame position, and the Delay Wrap Position will be at about 50% of full scale. As this input video delay with respect to the genlock reference frame position is changed from -0.5 to +0.5 frame periods, the delay through the module will change from about 6 to 7 frame periods, with the Delay Wrap Position changing from about 0 to 100% of full scale.

In summary, the Electrical Length of the module can be estimated as the following:

- 1 frame minus 5 lines (Minimum Delay Mode not selected), or
- 150 pixels (Minimum Delay Mode selected) + Multi-Frame Delay + Delay Wrap Position (% of full scale) X (1 frame period).

Figure 24. Frame Sync Web Page – Local or Frame Bus Reference

Frame Sync 

Model: [8985FSP+GEN](#) Description: [HD/SD FS Proc Amp](#)
 Frame Location: [not assigned](#) , Slot: [9](#)
 Input Video Standard: [1080sf/24](#) Input Video: [Coax Input : Present](#)
 Output Timing Source: [Ref Bus 1](#) Split Screen: [Disabled](#)

Timing Adjustment	Minimum Delay Mode
<div style="border: 1px solid black; padding: 5px;"> <p style="text-align: center;">H Timing (pixels)</p> <p style="text-align: center;"> <input type="button" value="<<"/> <input type="button" value="<"/> <input type="text" value="0"/> <input type="button" value="*"/> <input type="button" value=">"/> <input type="button" value=">>"/> </p> <p style="text-align: center;"> <input type="button" value=" <"/> <input style="width: 100px;" type="text"/> <input type="button" value="> "/> </p> </div> <div style="border: 1px solid black; padding: 5px; margin-top: 5px;"> <p style="text-align: center;">V Timing (lines)</p> <p style="text-align: center;"> <input type="button" value="<<"/> <input type="button" value="<"/> <input type="text" value="0"/> <input type="button" value="*"/> <input type="button" value=">"/> <input type="button" value=">>"/> </p> <p style="text-align: center;"> <input type="button" value=" <"/> <input style="width: 100px;" type="text"/> <input type="button" value="> "/> </p> </div> <div style="border: 1px solid black; padding: 5px; margin-top: 5px;"> <p style="text-align: center;">Multi-Frame Delay (frames)</p> <p style="text-align: center;"> <input type="button" value="<<"/> <input type="button" value="<"/> <input type="text" value="3"/> <input type="button" value="*"/> <input type="button" value=">"/> <input type="button" value=">>"/> </p> <p style="text-align: center;"> <input type="button" value=" <"/> <input style="width: 100px; background-color: #008080;" type="text"/> <input type="button" value="> "/> </p> </div>	<div style="border: 1px solid black; padding: 5px; margin-top: 5px;"> <p style="text-align: center;">Loss of Signal Operation</p> <p> <input type="radio"/> Pass <input checked="" type="radio"/> Auto Freeze <input type="radio"/> Auto Blue </p> </div> <div style="border: 1px solid black; padding: 5px; margin-top: 5px;"> <p style="text-align: center;">Manual Freeze Mode</p> <p> <input checked="" type="radio"/> None <input type="radio"/> Frame <input type="radio"/> Field </p> </div>

Timing Status	
Total Video Delay (frames)	4.682133
Total Video Delay (msec)	191.9674
Delay Wrap Position	<div style="background-color: #0000FF; width: 100%; height: 15px;"></div>

Figure 25. Frame Sync Web Page – Input Reference

Frame Sync 

Model: [8985FSP+GEN](#) Description: [HD/SD FS Proc Amp](#)
 Frame Location: [not assigned](#) , Slot: [9](#)
 Input Video Standard: [1080sf/24](#) Input Video: [Coax Input : Present](#)
 Output Timing Source: [Input Video](#) Split Screen: [Disabled](#)

Timing Adjustment

H Timing (pixels)

V Timing (lines)

Multi-Frame Delay (frames)

Minimum Delay Mode

Enabled

Loss of Signal Operation

Pass

Manual Freeze Mode

None
 Frame
 Field

Timing Status

Total Video Delay (frames)	4.001248
Total Video Delay (msec)	164.0512
Delay Wrap Position	

Defaults

<< Previous

Functional View

Next >>

Color Correction Web Page

[9 8985FSP+GEN](#)

[Status](#)

[I/O Config](#)

[Video Input](#)

[System Config](#)

[Frame Sync](#)

[Color Correction](#)

[Video Proc](#)

[User Settings](#)

[Genlock](#)

[Video Out](#)

[Slot Config](#)

Use
this
link

On the 8985FSP module, use the Color Correction web page ([Figure 26 on page 53](#)) to make RGB gain, offset and gamma correction adjustments and control the Split Screen function.

The Color Correction processing must be enabled before adjustments can be made. Select the **VCC Enable** checkbox to enable these controls.

Color Correction

The Color Correction section provides the following RGB controls:

- **Gain Adjustments** – set the gain from 0 to 200% for the R, G, and/or B channel with the corresponding control or adjust all of the gains together by adjusting the **Total Gain** control.
- **Offset Adjustments** – set the offset from $\pm 100\%$ for the R, G, or B channel with the corresponding control or adjust all of the offsets together by adjusting the **RGB Offset** control.
- **Gamma Correction** – set gamma correction with the **R Gamma Correction**, **G Gamma Correction**, and/or **B Gamma Correction** or adjust all channels together using the **Total Gamma Correction** control. Raising the gamma above 1.0, brightens the gray intensity. Lowering the gamma below 1.0, darkens the gray intensity.

Split Screen

Use a horizontal or vertical split screen to compare the unprocessed input video (top or right) to the processed output video (bottom or left). This control is duplicated and tied together with the Split Screen controls on the System Config and Video Proc web pages. Changes made on any one of the Split Screen controls will control all three screens.

- **Split Enable** – enable the split screen by checking the **Split Enabled** checkbox.
- **Orientation** – select the orientation of the split screen with the **Vertical** or **Horizontal** radio button.
- **Position** – use this control to set the amount of horizontal or vertical split (10 to 90%) of unprocessed video to appear on the screen.

Figure 26. Color Correction Web Page

 **Color Correction** 

Model: [8985FSP+GEN](#) Description: [HD/SD FS Proc Amp](#)

Frame Location: [BAY 2](#) , Slot: [9](#)

Input Video Standard: [576i/50](#) Input Video: [Coax Input](#) : [Present](#)

Output Timing Source: [Local](#) Split Screen: [Disabled](#)

Color Correction

VCC Enable: <input checked="" type="checkbox"/> Enable		
<p>R Gain (%)</p> <p><< < 100 * > >></p> <p> < [] > </p>	<p>R Offset (%)</p> <p><< < 0 * > >></p> <p> < [] > </p>	<p>R Gamma Correction</p> <p><< < 1.00 * > >></p> <p> < [] > </p>
<p>G Gain (%)</p> <p><< < 100 * > >></p> <p> < [] > </p>	<p>G Offset (%)</p> <p><< < 0 * > >></p> <p> < [] > </p>	<p>G Gamma Correction</p> <p><< < 1.00 * > >></p> <p> < [] > </p>
<p>B Gain (%)</p> <p><< < 100 * > >></p> <p> < [] > </p>	<p>B Offset (%)</p> <p><< < 0 * > >></p> <p> < [] > </p>	<p>B Gamma Correction</p> <p><< < 1.00 * > >></p> <p> < [] > </p>
<p>Total Gain</p> <p><< < 0 * > >></p> <p> < [] > </p>	<p>RGB Offset (%)</p> <p><< < 0 * > >></p> <p> < [] > </p>	<p>Total Gamma Correction</p> <p><< < 0 * > >></p> <p> < [] > </p>

Defaults

Split Screen

Split	<input type="checkbox"/> Enabled
<p>Orientation</p> <p><input checked="" type="radio"/> Vertical</p> <p><input type="radio"/> Horizontal</p>	<p>Position (%)</p> <p><< < 50 * > >></p> <p> < [] > </p>

Video Proc Web Page

[9 8985FSP+GEN](#)

[Status](#)

[I/O Config](#)

[Video Input](#)

[System Config](#)

[Frame Sync](#)

[Color Correction](#)

[Video Proc](#)

[User Settings](#)

[Genlock](#)

[Video Out](#)

[Slot Config](#)

Use
this
link

On the 8985FSP module, the Video Proc web page ([Figure 27 on page 55](#)) provides overall video processing and Y/C clipping controls for the HD or SD signal.

Video Processing Controls

The Video Proc controls must be enabled by checking the **VPA Enable** checkbox.

The following controls are provided for video processing:

VPA (Video Proc Amp)

Use the controls below to adjust the video proc amp:

- **VPA Enable** checkbox – to enable the video proc amp controls, select the **VPA Enable** checkbox.
- **Y/Cb/Cr Gain** – set the gain for the Y, Cb, or Cr channel from 0 to 200% with the corresponding control or adjust all gains together by using the **Total Gain** control.
- **Y/Cb/Cr Offset** – set the offset $\pm 100\%$ for the Y, Cb, and Cr channels with the corresponding control.
- **Color Saturation** – adjust the percentage of color saturation relative to 100%.

Y/C Clip Controls

Use the following clipping controls to adjust levels on the output signal:

- **Clip Enable** checkbox – to enable the clip controls, select the **Clip Enable** checkbox.
- Use the **Y White Clip (%)** control to set the clipping level for the top end (white) of the luminance signal (positive excursions) from 50 to 109%.
- Use the **Y Black Clip (%)** control to set the clipping level for the bottom end (black) of the luminance signal (negative spikes and Super Black) from -7 to +50%.
- Use the **C White Clip (%)** control to set the clipping level for the top end (white) of the chrominance channel (clips white and reduces overall saturation level to fit within clip) from 50 to 109%.

Split Screen

Use a horizontal or vertical split screen to compare the unprocessed input video (top or right) to the processed output video (bottom or left). This control is duplicated and tied together with the Split Screen controls on the System Config and Color Correction web pages. Changes made on any one of the Split Screen controls will control all three screens.

- **Split Enable** – enable the split screen by checking the **Split Enabled** checkbox.
- **Orientation** – select the orientation of the split screen with the **Vertical** or **Horizontal** radio button.
- **Position** – use this control to set the amount of horizontal or vertical split (10 to 90%) of unprocessed video to appear on the screen.

Figure 27. Video Proc Web Pager

Video Processing Controls

VPA Enable: <input type="checkbox"/> Enable			
Y Gain (%) << < 100 * > >> < [] >	Cb Gain (%) << < 100 * > >> < [] >	Cb Offset (%) << < 0 * > >> < [] >	Y Offset (%) << < 0 * > >> < [] >
Color Saturation (%) << < 100 * > >> < [] >	Cr Gain (%) << < 100 * > >> < [] >	Cr Offset (%) << < 0 * > >> < [] >	Hue (Deg) << < 0 * > >> < [] >
Total Gain << < > >>			
Clip Enable: <input type="checkbox"/> Enable			
Y White Clip (%) << < 109.0 * > >> < [] >	Y Black Clip (%) << < -7.0 * > >> < [] >	C White Clip (%) << < 109.0 * > >> < [] >	

Defaults

Split Screen

Split	<input type="checkbox"/> Enabled
Orientation <input checked="" type="radio"/> Vertical <input type="radio"/> Horizontal	Position (%) << < 50 * > >> < [] >

User Settings Web Page

- [9 8985FSP+GEN](#)
- [Status](#)
- [I/O Config](#)
- [Video Input](#)
- [System Config](#)
- [Frame Sync](#)
- [Color Correction](#)
- [Video Proc](#)
- [User Settings](#)
- [Genlock](#)
- [Video Out](#)
- [Slot Config](#)

Use
this
link

The User Settings web page (Figure 28) provides a save/load function for configuration files and a way to recall factory defaults parameters and signal names for the entire module.

Recall Factory Defaults and Names

Use the two buttons at the bottom of the web page to do the following:

- **Set Factory Defaults** – select the **Set Factory Defaults** button to recall factory settings to the module. Defaults for all module parameters are listed in [Table 6 on page 75](#).
- **Set Factory Names** – select the **Set Factory Names** button to recall factory signal names to the module. Defaults for all signal names are displayed on the I/O Config web page shown in [Figure 18 on page 40](#).

Figure 28. Set Factory Defaults Web Page

User Settings

Model: [8985FSP+GEN](#) Description: [HD/SD FS Proc Amp](#)
Frame Location: [BAY 2](#) , Slot: [9](#)
Input Video Standard: [1080i/59.94](#) Input Video: [Coax Input : Present](#)
Output Timing Source: [Input](#) Split Screen: [Disabled](#)
Fiber Module Type: [Not Installed](#)

File Operations

[Save to...](#) [Load from...](#)

[Set Factory Defaults](#) Recall factory settings

[Set Factory Names](#) Recall factory names

File Operations

Configuration files from the 8985 module may be saved to a file and stored offline for later recall.

To save a file, do the following:

1. Save the current configuration on the module to a file by selecting the **Save to...** button which will bring up the File Download screen (not shown).
2. In the File Download screen select **Save**.
3. This will bring up the Save As screen shown in [Figure 29](#).
4. Enter a name in the File name field. This file is saved as a .bin type.

Figure 29. Save As Screen.

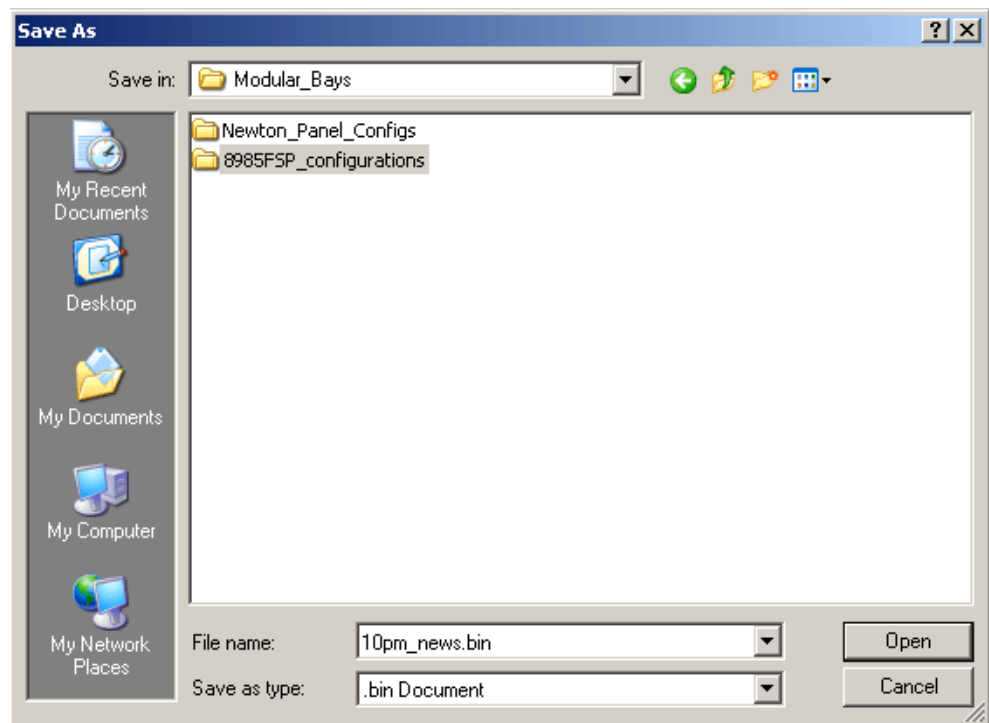

To load and recall a file, do the following:

1. Selecting the **Load From...** button on the User Settings web page ([Figure 28 on page 56](#)) which will bring up the Load Settings web page shown in [Figure 30 on page 58](#).
2. Enter a path and file name or select **Browse...** to locate the directory where the files have been saved.

Figure 30. Load Settings Web Page.

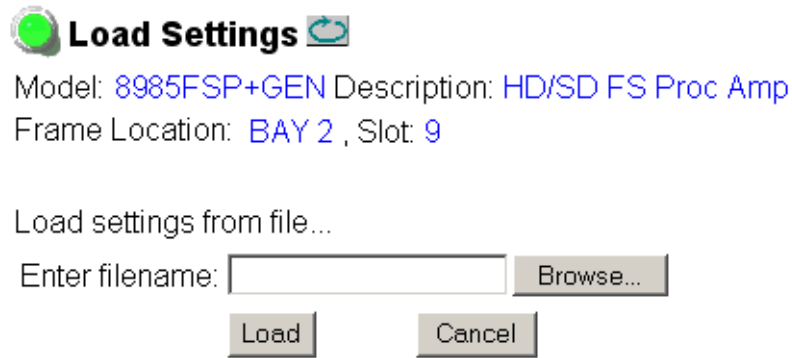

3. This will bring up the Choose File screen shown in [Figure 31](#).
4. Select a file to load and then press **Open** to bring the file into the filename field.
5. Press the **Load** button in the Load Settings web page ([Figure 30](#)) to load the file to the module.

Note The parameters stored in this file will immediately be loaded to the module. This could change the status of the output so be sure to be aware of the changes or be off air before uploading a configuration file.

Figure 31. Choose File Screen

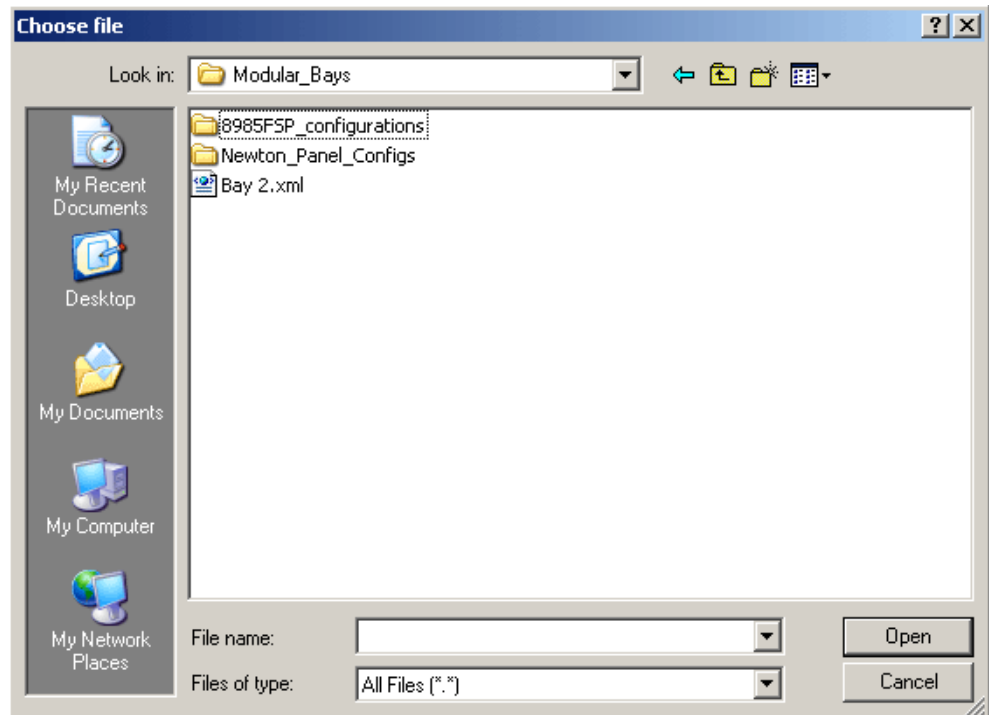

Genlock Web Page

[9 8985FSP+GEN](#)

[Status](#)

[I/O Config](#)

[Video Input](#)

[System Config](#)

[Frame Sync](#)

[Color Correction](#)

[Video Proc](#)

[User Settings](#)

[Genlock](#)

[Video Out](#)

[Slot Config](#)

Use
this
link

The Genlock web page ([Figure 32 on page 60](#)) is present on 8985FSP + GEN and 8985FS + GEN modules when an 8900GEN-SM submodule is installed.

Refer to the *8900GEN-SM Installation Manual* available online for complete details for configuring the 8900GEN-SM submodule.

This web page provides reporting status for the following genlock status items:

- Genlock – reports status of Genlock function as **Enabled** or **Freerun**.
- Status – reports whether the reference input is **Locked** or **Not Locked**.
- Firmware Version – reports the firmware version of the 8900GEN-SM submodule installed on this 8985FSP module.
- Hardware Version – reports the hardware version of the 8900GEN-SM submodule installed on this 8985FSP module.
- Ref Input Standard – reports the reference input standard as detected by the 8900GEN-SM submodule that is connected to the Genlock Loop on the 8900GFR-R rear module.
- Ref Input Frame Rate – reports the frame rate of the reference input as detected by the submodule.
- Output Bus Frame Rate – reports the frame rate being output on the frame bus.
- Output Bus – reports the reference bus (Ref Bus 1 or Ref Bus 2) being output from the submodule.

Genlock Control

The following controls are available for configuring the Genlock submodule:

- **Enable** or **Freerun** – select one of the radio buttons to enable the Genlock submodule or allow the reference to freerun.
- **Input Standard Selection** – use this control to set the input standard needed for the reference input. Refer to [Table 3 on page 61](#) for important notes on standard selection.
- **Loop Bandwidth** – set this control for either fast locking (**Fast Lock**) to the reference or for the lowest jitter performance (**Low Jitter**) depending on the stability of the reference signal being used.



For example, if Low Jitter is selected and the Status is still **Invalid** after one minute has passed, the input reference has excessive wander that cannot be tracked in Low Jitter mode. Switch to **Fast Lock** and verify Status is **Locked** after about 10 seconds.

Genlock Timing

Use the following controls to adjust the output timing of the genlock reference signal from this submodule:

- **Line Offset** – adjust the reference timing stream by standard definition line steps up to one full frame.
- **Coarse Offset** – provides coarse adjustment of the reference timing stream by 37 ns steps up to one line.
- **Fine Offset** – provides fine adjustment of the reference timing stream by steps up to 37 ns.

Figure 32. Genlock Web Page

 **Genlock** 

Model: [8900GEN-SM](#) Description: [GeckoFlex Genlock Submodule](#)
 Genlock: [Enabled](#) Ref Input Standard: [NTSC](#)
 Status: [Locked](#) Ref Input Frame Rate: [29.97](#)
 Firmware Version: [8](#) Output Bus Frame Rate: [29.97](#)
 Hardware Revision: [1](#) Output Bus: [Ref1](#)

Genlock Control

Genlock: <input checked="" type="radio"/> Enable <input type="radio"/> Freerun
Input Standard Selection: <input type="text" value="NTSC"/>
Loop Bandwidth: <input type="radio"/> Low Jitter <input checked="" type="radio"/> Fast Lock

Genlock Bus Timing

Line Offset	Coarse Offset (37ns)
<input type="text" value="0"/>	<input type="text" value="0"/>
<input type="text"/>	<input type="text"/>
Fine Offset (37ns/256)	
<input type="text" value="0"/>	
<input type="text"/>	

Drive Frame Reference Bus:

The external reference fed to the Genlock submodule must be configured to one of the frame rates in the reference Input Standard Selection pulldown on the Genlock web page. [Table 3](#) lists the available frame rates in the pulldown and the compatible reference inputs that will report a locked condition on the Genlock web page.

Note If the Input Selection Standard selected on the Genlock web page does not match the reference input exactly, a warning will be generated.

Table 3. Reference Frame Rate Compatibility

Genlock Input Standard Selection	Reference Detected	Mismatch Warning
NTSC	NTSC	None
	1080i 59.94 TLS	Yes ¹
	720p 59.94	Yes ¹
PAL	PAL	None
	1080i 50 TLS	Yes ¹
	720p 50 TLS	Yes ¹
1080i 59.94 TLS	1080i 59.94 TLS	None
	NTSC	Yes ¹
	720p 59.94 TLS	Yes ¹
720p 59.94 TLS	720p 59.94 TLS	None
	NTSC	Yes ¹
	1080i 59.94 TLS	Yes ¹
1080i 50 TLS	1080i 50 TLS	None
	PAL	Yes ¹
	720p 50 TLS	Yes ¹
720p 50 TLS	720p 50 TLS	None
	PAL	Yes ¹
	1080i 50 TLS	Yes ¹
1080p 24 TLS	1080p 24 TLS	None
	1080sf 24 TLS	Yes ¹
	PAL	Yes ¹
	1080i 50 TLS	Yes ¹
	720p 50 TLS	Yes ¹
1080sf 24 TLS	1080sf 24 TLS	None
	1080p 24 TLS	Yes ¹
	PAL	Yes ¹
	1080i 50 TLS	Yes ¹
AES 48K	720p 50 TLS	Yes ¹
	AES 48K	None
	AES 96K	Yes ¹
	Word Clock 48K	Yes ¹
	Work Clock 96K	Yes ¹

Table 3. Reference Frame Rate Compatibility

Genlock Input Standard Selection	Reference Detected	Mismatch Warning
AES 96K	AES 96K	None
	AES 48K	Yes ¹
	Word Clock 48K	Yes ¹
	Work Clock 96K	Yes ¹
Word Clock 48K	Word Clock 48K	None
	AES 48K	Yes ¹
	AES 96K	Yes ¹
	Work Clock 96	Yes ¹
Word Clock 96K	Word Clock 96K	None
	AES 48K	Yes ¹
	AES 96K	Yes ¹
	Work Clock 48K	Yes ¹

¹ This input standard will lock but will generate a Warning on both the Genlock and Status web pages but will not affect the locked condition.

Video Out Web Page

[9 8985FSP+GEN](#)

[Status](#)

[I/O Config](#)

[Video Input](#)

[System Config](#)

[Frame Sync](#)

[Color Correction](#)

[Video Proc](#)

[User Settings](#)

[Genlock](#)

[Video Out](#)

[Slot Config](#)

Use
this
link

Use the Video Out web page ([Figure 33](#)) to enable or disable the SFP Fiber Optic submodule outputs when present and disable EDH insertion if desired.

Note Fiber optic outputs will be present when either the 1310NM-DTL or 1310NM-TRL Fiber Optic submodule is installed.

Output Enables

This section provides the following for the video output signal:

- **Fiber TX1** – check the **Enabled** checkbox to enable the output (1310NM-DTL submodule installed).
- **Fiber TX2** – check the **Enabled** checkbox to enable the output (1310NM-TRL or 1310NM-DTL submodule installed).

Figure 33. Video Out Web Page

Video Out

Model: [8985FSP+GEN](#) Description: [HD/SD FS Proc Amp](#)

Frame Location: [QA Bay 2- test](#) , Slot: [9](#)

Input Video Standard: [480i/59.94](#) Input Video: [Coax Input](#) : [Present](#)

Output Timing Source: [Ref Bus 1](#) Split Screen: [Disabled](#)

Fiber Module Type: [Not Installed](#)

Output Enables

Fiber TX1	Fiber TX2
<input type="checkbox"/> Enabled	<input type="checkbox"/> Enabled

Defaults

Slot Config Web Page

[9 8985FSP+GEN](#)

[Status](#)

[I/O Config](#)

[Video Input](#)

[System Config](#)

[Frame Sync](#)

[Color Correction](#)

[Video Proc](#)

[User Settings](#)

[Genlock](#)

[Video Out](#)

[Slot Config](#)

Use
this
link

Use the Slot Config web page shown in [Figure 34 on page 65](#) to perform the following functions on the module.

Note This Slot Config web page reflects the use of 8900NET (Net Card) software version 4.3.0.

Locate Module

Selecting **Flash** from the **Locate Module** pulldown flashes the yellow COMM and CONF LEDs on the front of the module so it can be located in the frame.

Slot Identification

You may identify the module by typing a specific name in the **Name** field. The assigned name is stored on the 8900NET module and travels with the 8900NET module if it is moved to another frame. Select **Default** to enter the factory default module name.

An asset identification may be entered in the **Asset Tag** field. This will appear on the module Status web page and in the NetConfig inventory report.

Slot Memory

The slot configuration for each media module is automatically polled and refreshed periodically (about every 50 minutes) by the 8900NET module when the **Always Slot Refresh** checkbox on the 8900NET Configuration web page (with 4.3.0 software) and/or the **Restore upon Install** checkbox on any media module Slot Config web page is selected.

When the **Restore upon Install** checkbox on any media module Slot Config web page has been selected, the current configuration from that module is saved in slot memory on the 8900NET module. This allows the current module to be removed and when another module of the same part number, and software version is installed, the configuration saved to the 8900NET module will be downloaded to the installed module. The **Restore upon Install** checkbox must be selected before the current module with the saved configuration is removed.

Note Make sure all modules of the same model type are running the same software version and have the same part number silk-screened on the printed circuit board. Downloading a configuration to a module with a different software version or part number can produce unexpected results.

If a different type of module is installed in this slot, a warning message will state that the original module type has been replaced with another module type. In this case, a **Clear** button will appear allowing you to clear the stored configuration from the previous module.

You may also select the **Learn Module Config** button at any time to save the current configuration for this slot. The configuration is saved on the 8900NET module. If the 8900NET module is removed or powered down, the stored configurations are not saved.

When no **Restore upon Install** checkboxes on any of the media module Slot Config web pages are selected and the **Always Slot Refresh** checkbox on the 8900NET Configuration web page is unchecked, the slot refresh polling function on the 8900NET module will be disabled. See the **Always Slot Refresh** checkbox description in the *8900NET (Net Card) Network Interface Module Instruction Manual* for more details.

Note Uncheck the **Restore Upon Install** button before downloading new software.

Figure 34. Slot Config Web Page

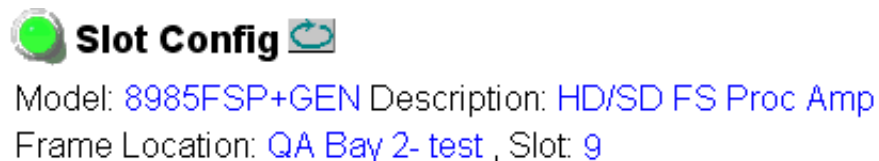

Frame Health Reports Link

Select the Frame Health Reports link to open the 8900NET module Frame Alarm Reporting web page. This web page allows configuration of the alarms and warnings that are reported to the external Frame Health Alarm connector on the rear of the GeckoFlex frame.

LED Reports Link

Select the LED Reports link to open the 8900NET LED Reporting web page. Normally, every module in the frame will report to the 8900NET module any Fault, Signal Loss, Reference Loss, or Config Error conditions. These conditions will be reflected by the status LEDs on the 8900NET module. Using this web page, any of these conditions on this module and other frame components such as the power supplies and fans, can be disabled from being reported to the 8900NET module.

SNMP Trap Reports Link

Select the SNMP Trap Reports link to open the 8900NET SNMP Reporting web page. This link will only be present when SNMP Agent software has been installed on the 8900NET module. This web page allows configuration of which alarms and warnings that are reported to the SNMP management software.

Refer to the *8900NET Instruction Manual* for complete details on using the 8900NET web pages.

Software Updating

Software updating of the 8985FSP/FS modules is done using the Net-Config Networking Application PC option. This application is available free of charge from the Thomson Grass Valley web site.

Software updating requires the presence of the 8900NET (Net Card) module running software version 4.3.0. Refer to [Software Requirements on page 11](#) for acquiring the latest version 8900NET software.

All modular product documentation can be found in PDF format on the Thomson Grass Valley web site at this link:

www.thomsongrassvalley.com/docs/modular

Specifications

Table 4. 8985FSP/FS Specifications

Parameter	Value
Serial Digital Input	
Number and type of input	1 non-isolated terminating BNC
Input impedance	75 ohm
Input return loss	> 15 dB from 5 MHz to 1.5 GHz
Input signal level	800 mV \pm 10%
Input DC tolerance	+/- 0.25 mV maximum
Serial mode hum voltage	1 V p-p to 60 Hz maximum
Common mode rejection ratio (CMMR)	N/A
Auto equalization	325 meters of Belden 1694A or 270 Mb/s 125 meters of Belden 1694A for 1.5 Gb/s
Reclocking	Yes
Input lock range	\pm 100 PPM
Input signal type	HD-SDI: <ul style="list-style-type: none"> • 1080i 59.94/50 • 1080p24/sF24 • 720p 59.94/50 SD-SDI: <ul style="list-style-type: none"> • 480i/59.94 (NTSC) • 576i/50 (PAL-B)
Reference Signal Input (8900GEN-SM Genlock Submodule Installed)	
Signal Type:	
Analog color black	525i/59.9(NTSC); 625i/50(PAL-B); SMPTE318M (NTSC with 10 field AES ID)
Tri-level sync	720p59.94; 1080i59.94, 720p50, 1080i50, 1080p24, 1080sF/24
4 V composite sync	Not supported
Active video	Not supported due to effects on timing
Reference signal level	300 mV p-p \pm 6 dB
Reference signal to noise ration (S/N)	> 46 dB S/N
Serial Digital Outputs	
Connector type	Coax BNC, optional fiber optic SFP
Number of outputs	4
Output impedance	75 ohm
Return loss	> 15 dB 5 MHz-270 MHz > 15 dB typical 270 MHz to 1.5 GHz
Output signal level	SDI 800 mV p-p, \pm 10%
Rise/fall time (20-80%)	140 ps for HD 500 ps for SD
Output jitter (FS mode, in low jitter mode)	< 0.2 UI HD > 100 kHz < 1.0 UI HD 10 Hz-100 kHz < 0.2 UI SD > 1 kHz < 0.2 UI HD 10 Hz-1 kHz

Table 4. 8985FSP/FS Specifications - (continued)

Parameter	Value
Electrical Length	
Input to output delay: Default with zero user input delay	
In delay mode or in genlock mode with zero input video delay with respect to genlock frame position (see Table 5 on page 69)	
Full-frame mode	1 frame periods in all formats
Minimum delay mode	~ 300 pixel periods in all formats
Input to output delay: User input delay in pixel steps ranging from 0 to 7 frames ¹	
In delay mode or in genlock mode with any input video delay with respect to genlock frame position	
Full-frame mode	1 frame minus 5 lines to 8 frames minus 5 lines ²
Minimum delay mode	150 pixels to 7 frames ³
Optical Video Receiver/Transmitter (1310NM-DRL, 1310NM-DTL, and 1310NM-TRL)	
Optical fiber interface	Compliant with SMPTE 291M-1998 and SMPTE 297M-2000
Input/Output configuration	2 inputs (DRL) or 1 input and 1 output (TRL) or 2 outputs (DTL)
Optical wavelength	1310 nm ± 40 nm
Minimum/maximum output power (Tx)	-12 dBm < or equal to Pw TX < or equal to -7.5 dBm
Maximum reflected power	4%
Transmission circuit fiber	Single mode
Minimum/maximum input power (Rx)	-12 dBm < or equal to Pw TX < or equal to -7.5 dBm
Detector threshold	+1 dBm
Power	
Power dissipation	< 8.0 W (with Genlock and fiber optic submodules)
Mechanical	
Frame type	GeckoFlex
Number of slots required	1 slot
Retainer clip screw torque	12 inch-lb./1.35 nm
Environmental	
Frame temperature range	See GeckoFlex frame specification
Operating humidity range	
Non-operating temperature	

¹ The User input delay is specified as 0 to 6 full frames, plus one frame in pixels and lines. The Delay Wrap Position on the Frame Sync web page roughly indicates what fraction of that last frame of adjustable delay is being used. Because the input video delay with respect to genlock frame position can vary, the Delay Wrap Position with respect to User Input Delay will vary.

² Full Frame Mode always has at least 1 frame minus 5 lines of electrical length.

³ Video distortion can occur with User Input Delay that gives ~150 pixels of electrical length. Increase the delay to give a total of ~300 pixels of delay for the optimum minimum delay setting.

The frame phase relationship between the SDI video stream and the analog reference signal is established according to SMPTE RP 168-2002. This defines the SDI video frame start occurring N pixel periods before the frame start of the analog video reference signal. N is defined for each video format in [Table 5](#).

Table 5. Frame Phase Relationship

Format	Standard	N
408i59.94	SMPTE 125M-1995	16
576i50	Rec. ITU-R BT.656-4	12
1080i59.94	SMPTE 274M-1998	88
720p59.94	SMPTE 296M-2001	110
1080i50	SMPTE 274M-1998	528
720p50	SMPTE 296M-2001	440
1080sF24	SMPTE 274-1998	638
1080p24	SMPTE 274-1998	638

Status Monitoring Summary

There are a number of ways to monitor frame and module status. These methods are summarized here. For more detailed information, refer to the *8900NET (Net Card) Network Interface Module Instruction Manual* and the *8900 Gecko* or *8900 GeckoFlex Frame Instruction Manuals*.

All modular product documentation is available on-line in PDF format at this link:

www.thomsongrassvalley.com/docs/modular

The main status monitoring methods include the following:

- External frame alarm output on the rear of the 8900 frame with reporting from the Module Health Bus and other frame status alarm reports,
- LEDs on the Frame, 8900NET module, and individual frame media modules,
- Web browser status reporting for each frame component, and
- SNMP traps, captured by Thomson Grass Valley's NetCentral or another SNMP Manager Application.

Note SNMP trap information is only available when an SNMP Agent has been installed and configured.

External Frame Alarm

An external Frame Alarm output is available on pins 8 and 9 of the RS-232 connector on the rear of the frame. The Frame Alarm outputs a voltage level indicating there is an alarm condition on the Module Health Bus or one of the other frame components reported to the Frame Monitor module in a Gecko 8900TF or GeckoFlex 8900FF frame or the 8900NET module in an 8900TFN and GeckoFlex 8900FFN frame.

- The Module Health bus is a separate line on the frame motherboard that provides a means for older or less capable modules (such as DAs with no microprocessor) that cannot communicate over the Frame (serial) bus to report warning and alarm conditions to the external Frame Alarm. All media modules in the frame report a voltage level to this line when a warning condition occurs on the module. The specific warning or module location is not reported, only an indication that an warning condition has occurred.
- Frame alarm reporting from other frame components can be enabled and disabled using DIP switches on the Frame Monitor and 8900NET module. For frames with an 8900NET module, the Frame Alarm Reporting web page allows configuration of the alarms and warnings that are reported to this external Frame Health Alarm.

LED Reporting

LEDs on the front of media modules, the Frame Monitor or 8900NET modules, and the front covers of the 8900TF/TFN and GeckoFlex FF/FFN frames indicate status of the frame and the installed power supplies, fans in the front covers, and module status. (The 8900TX-V/A and GeckoFlex 8900FX frames have no LED indicators on the front cover.)

LED reporting from the modules in the frame to the 8900NET module is configurable using the 8900NET LED Reporting web page. LEDs for the 8900NET module are described in the *8900NET (Net Card) Network Interface Instruction Manual*.

The Status LEDs for this module are described in [Operation Indicator LEDs on page 22](#).

Web Browser Interface

The 8900NET module controls a web browser GUI that indicates frame and module status on the following web pages:

- Frame Status web page – reports overall frame and module status in colored graphical and text formats. Refer to the [Figure 11 on page 30](#) for an example.
- Module Status web page ([Figure 11 on page 30](#)) – shows specific input and reference signal configuration error status to the module along with module status and information (part number, serial number, hardware version, software/firmware/boot versions, and Asset number (as assigned on the Slot Config web page).
- A Status LED icon on each web page reflects the module status on the module Status web page where warnings and faults are displayed and is a link to the module Status web page.

SNMP Reporting

The Gecko 8900 Series system uses the Simple Network Monitoring Protocol (SNMP) internet standard for reporting status information to remote monitoring stations. When SNMP Agent software is installed on the 8900NET module, enabled status reports are sent to an SNMP Manager such as the Grass Valley's NetCentral application.

Status reporting for the frame is enabled or disabled with the configuration DIP switches on the 8900NET module. Most module status reporting items can be enabled or disabled on individual configuration web pages.

Service

The 8985FSP/FS modules make extensive use of surface-mount technology and programmed parts to achieve compact size and adherence to demanding technical specifications. Circuit boards should not be serviced in the field unless directed otherwise by Customer Service.

Power-Up Diagnostic Failure

If the module has not passed self-diagnostics, do not attempt to troubleshoot. Return the unit to Grass Valley (see [Module Repair](#) below).

Troubleshooting

Electronic Circuit Breaker

An electronic circuit breaker on the module works during a fault condition or an overcurrent to cut off power to the module in place of a fuse.

If power has been cut off to module, remove the module and replace it in the frame to reset. If the problem persists contact Grass Valley Customer Service.

Module Repair

If the module is still not operating correctly, replace it with a known good spare and return the faulty module to a designated Grass Valley repair depot. Call your Grass Valley Customer Service representative for depot locations.

Contacting Grass Valley

If you need to contact Grass Valley for any module issues, refer to *Contacting Grass Valley* [on page 4](#) at the front of this document for the Grass Valley Customer Service Information number.

Functional Description

A block diagram of the 8985FSP module is shown in [Figure 35](#).

Figure 35. 8985FSP Block Diagram

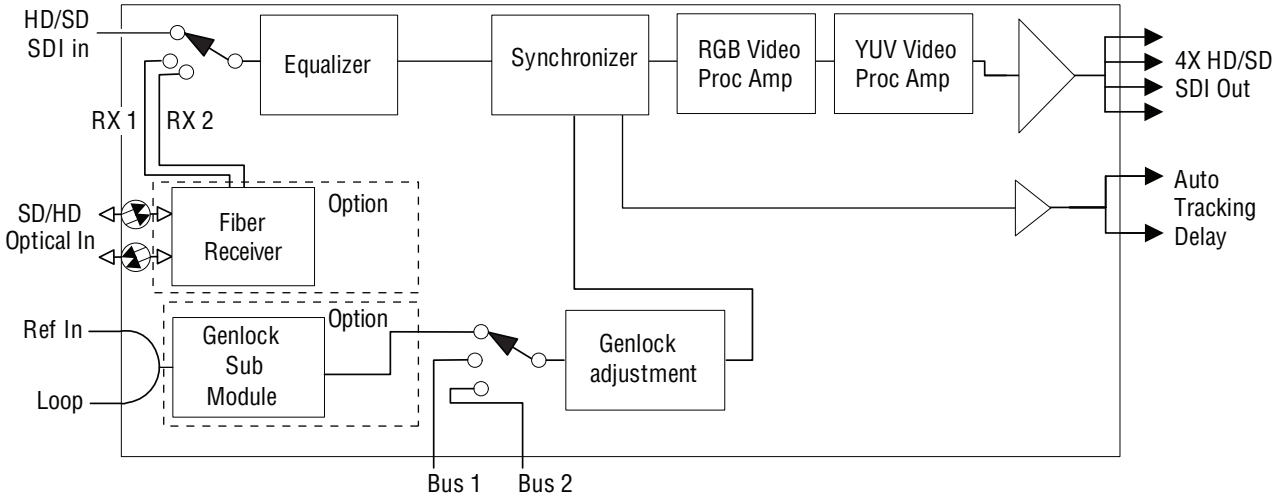

A block diagram of the 8985FS module is shown in [Figure 36](#).

Figure 36. 8985FS Block Diagram

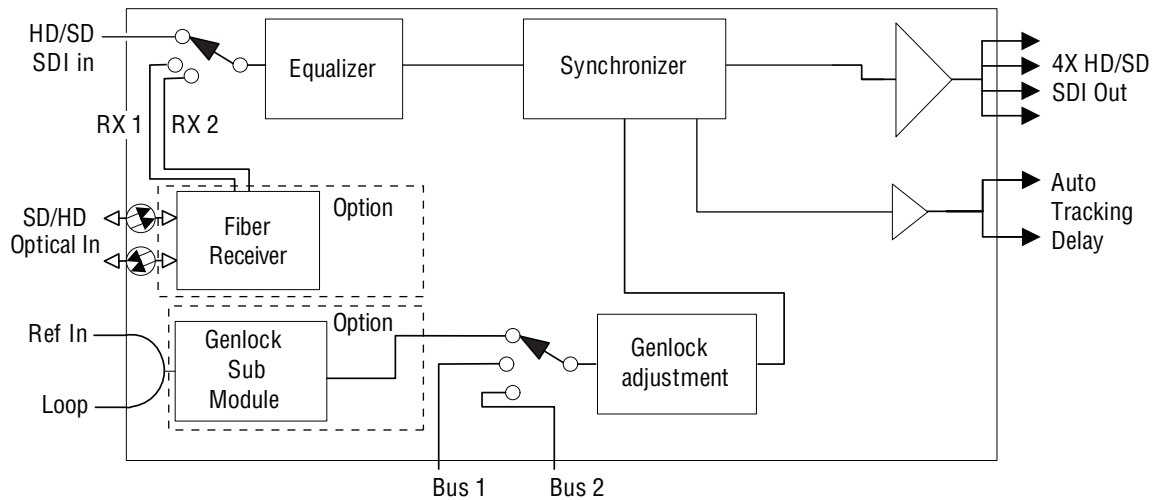

Configuration Parameter Summary

Table 6 provides a complete summary of the 8985FSP and 8985FS functions and a comparison of the functionality available with the web page and Newton control panel control type along with the ranges and default values for each parameter.

Table 6. Summary of 8985FSP/FS Configuration Functions

Function Type	Default	Range/Choices Resolution	Web Page/ Function Name	Newton Control Panel
Reference Signal Loss Reporting	On	On or Off	I/O Config/ Genlock Ref In Loop Reporting Enabled checkbox	N/A
Coax Input Signal Loss Reporting	On	On or Off	I/O Config/ COAX In Reporting Enabled checkbox	N/A
Fiber Input 1 and 2 Signal Loss Reporting	On	On or Off	I/O Config/ Fiber Video in/Out 1 and 2 Reporting Enabled checkbox	N/A
Video Input Selection	COAX	COAX, Fiber RX 1, or Fiber RX 2	Video In/ Video Input Select Video Input Selection radio button	N/A
Input video standard	Auto	Auto, 480i–(SD 59.94), 576i–(SD 50), 720p–(HD 59.94), 1080i–(HD 59.94), 720p–(HD 50), 1080i–(HD 50), 1080p–(HD 24), or 1080sf–(HD 24)	System Config/ Video I/O Configuration Input Video Standard pulldown	InVidStd
Select primary output timing source	Local	Local, Ref 1, Ref 2, or Input	System Config/ Output Timing Primary Source Selection radio button	OutClk
Select secondary output timing source	Local	Local, Ref 1, Ref 2, or Input	System Config/ Output Timing Secondary Source Selection radio button	OutClk
Test Output Color Bars signal	Disabled	Enable or Disable	System Config/ Test Output Colorbars Enabled checkbox	ClrBars
Select switch to primary source method	Auto	Auto or Manual	System Config/ Reference Restore Switch to Primary pulldown	RefSwBk
Select amount of delay for switching back to primary	30 seconds	30 to 93.97 seconds	System Config/ Reference Restore Reference Switchback Delay (Seconds)	RefSwDly

Configuration Parameter Summary

Table 6. Summary of 8985FSP/FS Configuration Functions

Function Type	Default	Range/Choices Resolution	Web Page/ Function Name	Newton Control Panel
Enable or disable split screen	Disabled	Enabled or Disabled	System Config/, or Color Correction/, or Video Proc/, or Split Screen Split: Enabled checkbox	SplitEn
Split screen orientation	Vertical	Horizontal or Vertical	System Config/, or Color Correction/, or Video Proc/, or Split Screen: Orientation: radio button	SSOrt
Split Screen position (% of unprocessed video)	50%	10 to 90% (1% steps)	System Config/, or Color Correction/, or Video Proc/, or Split Screen: Position (%)	SSPos
Enable minimum delay mode	Disabled	Enabled or Disabled	Frame Sync/ Minimum Delay Mode Enabled checkbox	N/A
Horizontal Timing	0	0 to 857 pixels (525) 0 to 863 pixels (625) (1 pixel steps)	Frame Sync/ Timing Adjustment/ Horizontal Timing (pixels)	HTiming
Vertical Timing	0	0 to 524 lines (524) 0 to 624 lines (624) (1 line steps)	Frame Sync/ Timing Adjustment Vertical Timing (lines)	VTiming
Multi-Frame Delay control	0	0 to 6 Frames	Frame Sync/ Timing Adjustment Multi-Frame Delay (Frames)	N/A
Minimum Delay Mode enable	Disabled	Enable or Disable	Frame Sync/ Minimum Delay Mode Enable checkbox	N/A
Loss of signal operation	AutoBlue	Pass Auto Freeze, or Auto Blue	Frame Sync/ Loss of Signal Operation radio button	LOS Oper
Manual freeze mode	None	None, Frame, or Field	Frame Sync/ Manual Freeze Mode radio button	ManFrzMode
VCC (Video Color Correction) enable control	Enable	Enable or Disable	Color Correction/ VCC Enable Enable checkbox	CC-Enable
Adjust R gain	100%	0 to 200% (1% steps)	Color Correction/ R Gain (%)	R Gn
Adjust G gain	100%	0 to 200% (1% steps)	Color Correction/ G Gain (%)	G Gn
Adjust B gain	100%	0 to 200% (1% steps)	Color Correction/ B Gain (%)	B Gn
Adjust total gain	100%	0 to 200% (1% steps)	Color Correction/ Total Gain (%)	RGB Gn
Adjust R offset	0	± 100% (1% steps)	Color Correction/ R Offset (%)	R Off
Adjust G offset	0	± 100% (1% steps)	Color Correction/ G Offset (%)	G Off
Adjust B offset	0	± 100% (1% steps)	Color Correction/ B Offset (%)	B Off
Adjust total offset	0	0 to 200% (1% steps)	Color Correction/ Total Offset (%)	RGB Off
Adjust R gamma	1.0	0.25 to 4.00 (0.01 unit steps)	Color Correction/ R Gamma Correction	RGmC

Table 6. Summary of 8985FSP/FS Configuration Functions

Function Type	Default	Range/Choices Resolution	Web Page/ Function Name	Newton Control Panel
Adjust G gamma	1.0	0.25 to 4.00 (0.01 unit steps)	Color Correction/ G Gamma Correction	GGmC
Adjust B gamma	1.0	0.25 to 4.00 (0.01 unit steps)	Color Correction/ B Gamma Correction	BGmC
Adjust total gamma	100	0.25 to 4.00 (0.01 unit steps)	Color Correction/ Total Gamma Correction	RBBGmC
Set Color Correction to unity	N/A	See Defaults column	Color Correction/ Defaults button	Unity-VCC
VPA (Video Proc Amp) enable control	Disable	Enable or Disable	Video Proc/ VPA Enable Enable checkbox	VPrC-Enable
Adjust Y gain (contrast)	100%	0 to 200% (1% steps)	Video Proc/ Video Processing Controls Y Gain (%)	Y Gain
Adjust color saturation (chroma gain)	100%	0 to 200% (1% steps)	Video Proc/ Video Processing Controls Color Saturation (%)	Chro Gn
Adjust Cb gain	100%	0 to 200% (1% steps)	Video Proc/ Video Processing controls Cb Gain (%)	Cb Gain
Adjust Cr gain	100%	0 to 200% (1% steps)	Video Proc/ Video Processing Controls Cr Gain (%)	Cr Gain
Adjust Y Offset (brightness)	0	± 100% (1% steps)	Video Proc/ Video Processing Controls Y Offset (%)	Y Off
Adjust Cb offset	0	± 100% (1% steps)	Video Proc/ Video Processing Controls Cb Offset (%)	Cb Off
Adjust Cr offset	0	± 100% (1% steps)	Video Proc/ Video Processing Controls Cr Offset (%)	Cr Off
Adjust hue	0	-180 to +179 degrees (1 degree steps)	Video Proc/ Video Processing Controls Hue (Deg)	Hue
Adjust total gain	0	0 to 200% (1% steps)	Video Proc/ Video Processing Controls Total Gain	VPA Gain
Reset VPA to unity	N/A	See Defaults column	Video Proc/ Default button	Unity-VPA
Clip enable control	Disable	Enable or Disable	Video Proc/ Video Processing Controls Clip Enable checkbox	ClipEn
Y White Clip	109%	50 to 109%	Video Proc/ Video Processing Controls Y White Clip (%)	YWhtClip
Y Black Clip	-7%	-7 to +50%	Video Proc/ Video Processing Controls Y Black Clip (%)	YBlkClip
C White Clip	109%	50 to 109%	Video Proc/ Video Processing Controls C White Clip (%)	CWhtClip
Recall factory default parameters	N/A	See Defaults column	User Settings/ Recall Factory Defaults Set Factory Defaults button	N/A

Configuration Parameter Summary

Table 6. Summary of 8985FSP/FS Configuration Functions

Function Type	Default	Range/Choices Resolution	Web Page/ Function Name	Newton Control Panel
Recall factory default signal names	N/A	See <i>I/O Config Web Page</i> on page 39.	User Settings/ Recall Factory Names Set Factory Names button	N/A
Genlock enable control	Enable	Enable or Freerun	Genlock/ Genlock Control Enable or Freerun radio button	GLEnable
Genlock input standard selection	1080i 59.94	NTSC, PAL, 1080i 59.94 720p 59.94 1080i 50 720p 50 1080p 24, 1080sF 24, AES 46K, AES 96K, Word Clock 46K, or Word Clock 96K	Genlock/ Genlock Control Input Standard Selection pulldown	GLInSel
Set loop bandwidth	Low Jitter	Low Jitter or Fast Lock	Genlock/ Genlock Control Loop Bandwidth radio button	GLLoopBW
Set line offset (SD standard settings)	0 lines	NTSC: 0 to 524 lines PAL: 0 to 624 lines 1080i 59.94: 0 to 524 lines 720p 59.94: 0 to 524 lines 1080i 50: 0 to 624 lines 720p 50: 0 to 624 lines 1080p 24: 0 to 624 lines 1080sf 24: 0 to 624 lines AES 48K: 0 to 624 lines AES 96K: 0 to 624 lines Word Clock 48K: 0 to 624 lines Word Clock 96K: 0 to 624 lines	Genlock/ Genlock Bus Timing Line Offset control	GLLineOff
Set coarse offset	0	NTSC: 0 to 1715 PAL: 0 to 1727 1080i 59.94: 0 to 1715 720p 59.94: 0 to 1715 1080i 50: 0 to 1727 720p 50: 0 to 1727 1080p 24: 0 to 1727 1080sf 24: 0 to 1727 AES 48K: 0 to 1727 AES 96K: 0 to 1727 Word Clock 48K: 0 to 1727 Word Clock 96K: 0 to 1727	Genlock/ Genlock Bus Timing Coarse Offset control (37 ns)	GLcors
Set fine offset	0	All Formats: 0 to 255	Genlock/ Genlock Bus Timing Fine Offset control	GLfine
Set reference source to drive frame bus	Off	Off or Auto	Genlock/ Drive Frame Reference Bus: pulldown	GLBusDrv
Enable Fiber TX1 output (1310NM-TRL or 1310NM-DTL fiber optic submodule installed).	Not Enabled	Enabled or Not Enabled	Video Output/ Fiber TX1 Enabled Checkbox	N/A
Enable Fiber TX2 output (1310NM-TRL or 1310NM-DTL fiber optic submodule installed).	Not Enabled	Enabled or Not Enabled	Video Output/ Fiber TX2 Enabled Checkbox	N/A

Index

Numerics

- 8900GFR-R rear module
 - cabling [20](#)
 - installation [15](#)
- 8900NET module
 - required software version [27](#)
 - software updating requirement [11](#)
- 8985FS module
 - block diagram [73](#)
 - features [10](#)
- 8985FSP module
 - block diagram [73](#)
 - features [10](#)
- 8985PRC module [7](#)

A

- Auto Blue
 - overview [25](#)
 - remote control [48](#)
 - summary table [76](#)
- Auto Freeze
 - overview [25](#)
 - remote control [48](#)
 - summary table [76](#)
- auto tracking delay outputs
 - cabling [21](#)
- auto-sensing video input [42](#)

B

- blank rear cover [15](#)

C

- cabling [20](#)
- circuit breaker [72](#)
- Clear button [64](#)
- clip controls [54](#)
- Coarse adjust button
 - overview [31](#)

- coax outputs
 - cabling [21](#)
- coax video input
 - cabling [21](#)
- color correction (VCC)
 - overview [26](#)
 - remote control [52](#)
 - summary table [76](#)
- Color Correction web page [52](#)
- COMM LED [23](#)
- CONF LED
 - LED table [23](#)
- configuration
 - Remote, GUI [27](#)
 - summary table [75](#)
- control panel [28](#)

D

- delay wrap position [49](#)
- documentation online [4](#)

E

- external frame alarm [70](#)

F

- factory default names
 - I/O Config web page [39](#)
 - remote control [56](#)
- factory defaults
 - recall with remote controls [56](#)
 - summary table [75](#)
- FAQ database [4](#)
- FAULT LED
 - states [23](#)
- fiber optic cleaning kit [20](#)
- file operations (save and load) [57](#)
- Fine adjust button
 - overview [31](#)

- frame bus jumpering 17
- Frame Health Reporting 66
- Frame Status web page 71
- Frame Sync web page 48
- frequently asked questions 4
- FRM1 LED 23
- FRM2 LED 23
- front edge configuration controls 27
- front module
 - installation 18
 - removal 18

G

- gamma correction
 - overview 26
 - summary table 76
 - web page 52
- GeckoFlex frame
 - external frame alarm 70
 - module placement 13
- Genlock Loop
 - cabling 21
 - I/O Config web page 39
- Genlock submodule
 - installation 16
 - web page 59
- graphical user interface (GUI) 33
- Grass Valley web site 4

H

- horizontal timing
 - overview 25
 - remote control 48
 - summary table 76

I

- I/O Config web page 39
- input video standard
 - summary table 75
- installation
 - 8900GFR-R rear module 15
 - front module 18
 - Genlock submodule 16
 - overview 11

- precautions 13
- SFP Fiber Optic submodule 19

L

- LED Reporting 66
- LEDs
 - front edge 22
 - Names and Meanings table 23
- Local/Remote jumper
 - operation 27
- Locate Module function 64
- loss of signal reporting
 - operation, remote control 48
 - operation, summary table 76
 - remote controls 39
 - summary table 75

M

- manual freeze
 - remote control 48
 - summary table 76
- minimum delay mode 25, 48
- Module Health Bus 70
- module installation precautions 13
- module repair 72
- Module Status web page 71
- multi-frame delay 25, 48

N

- NetConfig
 - updating software 66
- Newton Control Panel
 - overview 28
 - summary table 75

O

- online documentation 4
- output timing source
 - overview 24
 - remote control 46
 - summary table 75

P

Primary-Secondary Phase Difference [47](#)
 PWR LED [23](#)

R

rear module
 installation precautions [13](#)
 REF IN LED [23](#)
 Reference Restore control [46](#)
 Refresh button [31](#)
 REM OVR LED [23](#)
 Restore upon Install checkbox [64](#)
 Retainer clips
 removal tool [15](#)
 screw torque specification [14, 68](#)

S

service [72](#)
 SFP Fiber Optic submodule
 cabling [20](#)
 input cabling [21](#)
 installation and removal [19](#)
 output cabling [21](#)
 signal naming
 on I/O Config web page [39](#)
 Slot Config web page [64](#)
 slot memory [64](#)
 SNMP reporting
 enabling [66](#)
 overview [71](#)
 software download from web [4](#)
 software updating [66](#)
 software updating requirements
 8900NET module [11](#)
 specifications [67](#)
 split screen
 overview [25](#)
 remote control, Color Correction web page [52](#)
 remote control, System Config web page [47](#)
 remote control, Video Proc web page [55](#)
 summary table [76](#)
 status monitoring
 summary [70](#)

Status web page [35](#)
 System Config web page [42](#)
 system configuration
 overview [24](#)
 remote controls [42](#)

T

troubleshooting [72](#)

U

user settings
 overview [26](#)
 User Settings web page [56](#)

V

vertical timing
 overview [25](#)
 remote controls [48](#)
 summary table [76](#)
 VID IN LED [23](#)
 Video Input web page [41](#)
 video inputs
 auto-sensing [42](#)
 configuring, remote control [41](#)
 specifications [67](#)
 summary table [75](#)
 Video Output web page [63](#)
 video outputs
 cabling [21](#)
 fiber optic, summary table [78](#)
 overview [26](#)
 video proc amp (VPA)
 overview [26](#)
 remote controls [54](#)
 summary table [77](#)
 Video Proc web page [54](#)
 video processor
 clip controls [54](#)

W

Waiting web page message [43](#)
 web browser
 links [34](#)

Index

- overview [29](#)
- web site
 - documentation [4](#)
 - FAQ database [4](#)
 - Grass Valley [4](#)
 - software download [4](#)