

DISCONTINUED



CopperHead

Camera-backed Interface Systems

**Includes Analog, Digital, Cine, Y-U-V, and Down-converter versions
as well as information on use with the HDX and Power Plus systems**

User Manual

Telecast Fiber Systems, Inc.
102 Grove Street
Worcester, MA 01605
Tel: 508-754-4858
Fax: 508-752-1520
www.telecast-fiber.com

Table of Contents

Introduction to the Telecast CopperHead	4
Information that CopperHead Receives and Sends	5
Unpacking and Installing CopperHead	6
Attaching CopperHead to Your Camera	6
Connecting the Camera Unit and Base Station Cables	7
Remote Connections - Camera and the Camera Unit (only)	9
Remote Connection - Camera Unit, Camera, and Tilt Head	10
Base Station Cable to the Remote Controller	10
Camera Unit –Operator Side	12
Camera Unit –Connector Side	13
Base Station, Front Panel	14
Base Station, Rear Panel	15
Attaching the Base Station Rack Mount Flanges	16
Power Systems	17
Optical Fiber	18
CopperHead Operation	19
Shutting Down CopperHead	20
Accessory List	20
Repair	20
Appendix	21
Fiber Cables	21
Various Connector Drawings and Pinouts	21
Tally Operation	26
Power Plus Operation	27
Specifications	28
Limited Warranty Statement	30

List of Figures

Figure 1.	CopperHead System	4
Figure 2.	CopperHead Battery Compatibility	6
Figure 3.	Attaching the CopperHead	7
Figure 4.	Camera Unit, Operator Side	12
Figure 5.	Camera Unit, Connector Side	13
Figure 6.	Base Station, Front Panel	14
Figure 7.	Base Station, Rear Panel	15
Figure 8.	Attaching the Rack Mount Flanges	16
Figure 9.	Optical Connector Options	18
Figure 10.	10/ 12-Pin Hirose & DB-15 Connectors	21
Figure 11.	9-Pin D-type Connector	23
Figure 12.	DB-15 Audio Connector – Base side	25
Figure 13.	Tally Wiring Diagram	26
Figure 14.	Power Plus Wiring Diagram	27

List of Tables

Table 1.	Fiber Signals and Signal Directions	5
Table 2.	Camera Unit Signal Cables	9
Table 3.	Cables for Camera Remote (only)	9
Table 4.	Cables for Camera Remote with PTZ	10
Table 5.	Cables between Base Station and RCP	11
Table 6.	Fiber Selections	21
Table 7.	10-Pin Hirose Remote Pin-out	22
Table 8.	12-Pin Hirose Signal Pin-out	22
Table 9.	DB-15 (VGA) Signal Pin-out	22
Table 10.	Tally/RS-232 Connector Pinouts on Base	23
Table 11.	Camera RCP Pinouts on Base	23
Table 12.	Headset Pin-out – Camera side	24
Table 13.	Intercom Pin-out – Base side	24
Table 14.	Audio XLR Pinout	24
Table 15.	XLR Power Connections, Base Station	24
Table 16.	DB-15 Cine Audio Connector – Base side	25
Table 17.	XLR-5 Audio Pin out – Cine Camera Side	25
Table 18.	DB-9 Connector on CHCS Breakout Cable	26

Introduction to the Telecast CopperHead

The Telecast CopperHead is a camera video, audio and data multiplexing system that installs between a portable video camera and its battery and connects via a single fiber optic cable to a Base Station in a truck or studio. All video, audio and data usually carried on Triax or multi-core cable is sent, bi-directionally, over a single lightweight fiber over distances as long as 5 km.

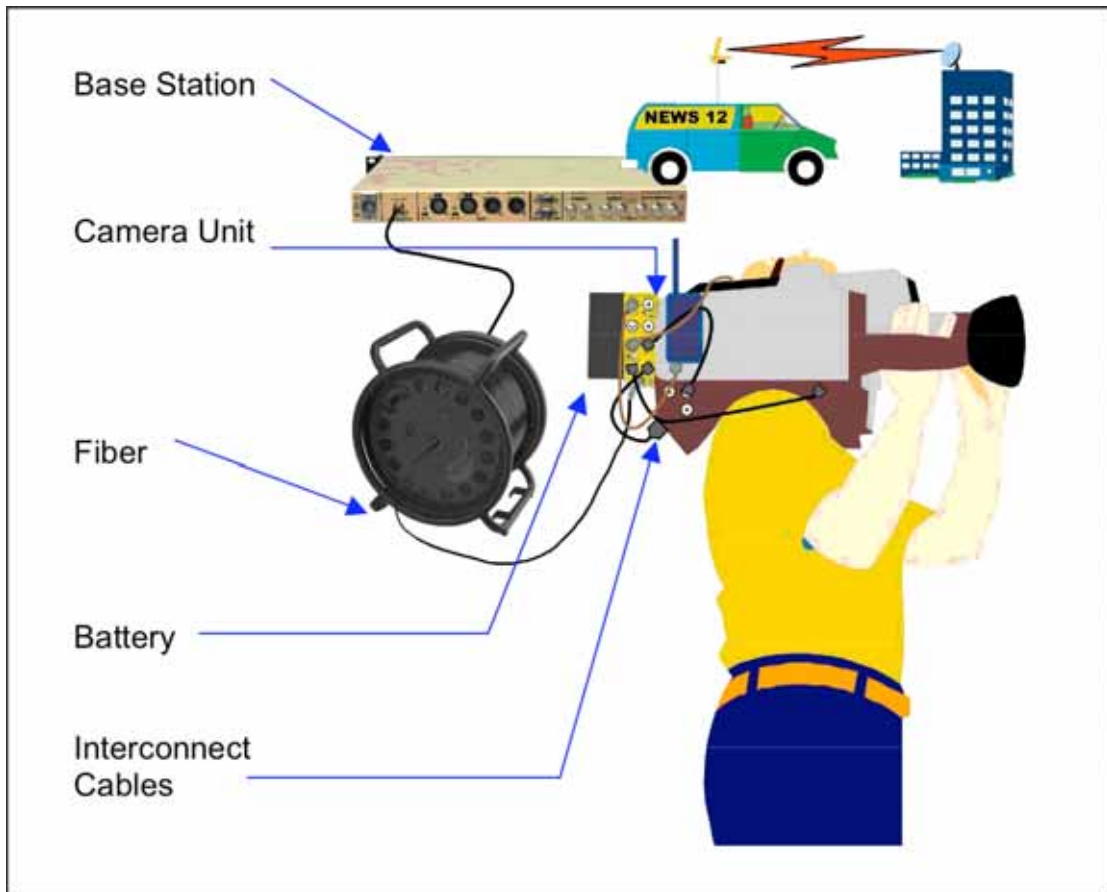

Figure 1: CopperHead System

A CopperHead system consists of the basic components shown in Figure 1.

- The Camera Unit fits between the battery and the camera. CopperHead is configured at time of purchase with special interface plates to accommodate the appropriate camera battery type.
- The camera Battery attaches to the Camera Unit, which in turn, attaches to the video camera. Batteries accommodated are Sony V, PAG, and Anton-Bauer.
- The Base Station multiplexes the optical signals to and from the Camera Unit and serves as the interface to your broadcast truck electronics.

- The Interconnecting Cables are used in various configurations depending on the camera and remote controller in use and on the signals that you want to send to and from the Base Station. Cables are supplied in your purchase order configuration.
- The Fiber Optic Cable connects the Camera Unit with the Base Station. The cable type is sturdy Tactical rated fiber in core counts of 1,2 and 4.

Information that CopperHead Receives and Sends

The Camera Unit multiplexes electrical signals from the camera and other remote sources and converts them to an optical signal for transmission over the fiber. Simultaneously, an optical return signal is received at the Camera Unit from the Base Station; this signal is then converted to electrical analog information for use by the camera, camera operator, and auxiliary equipment at the camera location. The signals carried by the fiber, and the directions of information flow, are given in Table 1. The optical system permits fiber lengths as detailed in Table 6 on page 15.

Camera to Base	Signal	Base to Camera
A,D,C	Program video	
D,C	SDI/HD/SDI video	
A,D,C	Audio 1: Program audio	
A,D,C	Audio 2: Auxiliary audio	
	4 Channels Return Audio	C
	Tally/Call	A,D,C
	Return Video	A,D,C
	Black Burst/Gen Lock	A,D,C
A,D,C	Intercom, 4-wire	A,D,C
A,D,C	RS-232 signals	A,D,C
A,D,C	Camera Control signals	A,D,C

*Table 1: Fiber Signals and Signal Directions
A=Analog, D=Digital, C=Cine*

Unpacking and Installing CopperHead

The following components are shipped with the CopperHead system:

- Camera Unit
- Base Station
- External power supply for the Base Station
- Cable sets as required by your camera and remote controller types to connect the CopperHead Camera Unit to the camera, and to connect the Base Station to the remote controller

NOTE: You must use your own cables to make connections for Tally, Black Burst/Gen Lock, Base Station monitor, and other ancillary signals and equipment. See the appendix for suggestions on some of these.

- Hardware kits for rack mounting the Base Station
- Portable fiber reel with fiber per your purchase order

Inspect all components for scratches and other mechanical damage, and inspect the electrical connectors for bent or damaged pins and latches. Report any missing or damaged components to Telecast Fiber Systems, Inc.

NOTE: Leave the protective caps on the optical connectors whenever the fiber is disconnected.

Attaching CopperHead to Your Camera

The Camera Unit mounts between the camera and its battery pack.

Figure 2 shows the CopperHead attached, left to right, to the three most common 12 VDC battery types used with video cameras: Sony V, PAG, and Anton Bauer.



Figure 2: CopperHead Battery Compatibility

To mount the Camera Unit:

1. Check that the camera power is off.
2. Check that the Camera Unit power slide switch shown in Figure 4 on page 7 is off.
3. Remove the existing battery pack from the camera.
4. Visually assure that the mounting plates on either side of the Camera Unit is the same as those on your battery and camera. Remember, the Camera Unit fits in place of the battery on the camera, and the battery is mounted to the Camera Unit.
5. Mount the Camera Unit to the flange on the CopperHead as shown below in Figure 3.
6. Mount the battery to the Camera Unit as shown above in Figure 2.

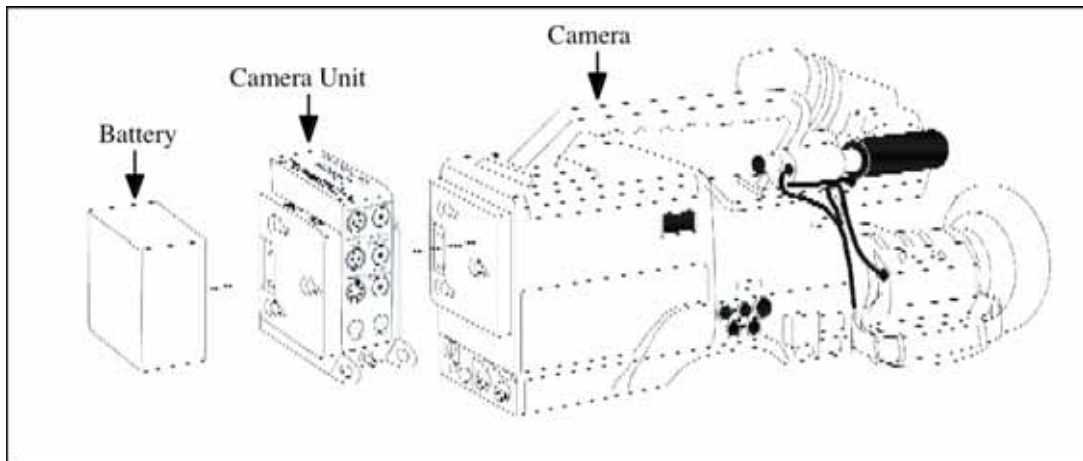

Figure 3: Attaching the CopperHead Between Camera and Battery

Connecting the Camera Unit and Base Station Cables

CopperHead uses sets of interconnecting cables at the Camera Unit and at the Base Station. Cable configurations differ with camera type; contact Telecast for the appropriate wiring diagram for your camera. You can also connect the Camera Unit and the camera using your own custom-assembled cables.

CAUTION: Before connecting any cables, verify that you have the correct cables for your camera type by checking in the appropriate table.

Telecast provides cable sets for various cameras and remote controllers. Table 2 through Table 5 list cables for some of the many supported camera systems. Electrical pinouts for the various connectors are given in the Appendix.

Signal Connections between the Camera and the CopperHead Camera Unit

The primary connection between your camera and the Camera Unit are via the **Remote** and **Signal** connectors on the Camera Unit, and the 26-pin standard connector and other locations on the camera.

Find your Signal cable and connect it. As the second column in Table 2 indicates, these signal connections are via:

- a special Breakout multi-connector cable provided by Telecast or
- a standard 26-pin standard connector at the camera

In both cable types, the Signal input/output on the Camera Unit is via the 12-pin Hirose connector shown on the right in Figure 9 on page 16. The pinouts are in Table 7 on page 16. These **Signal** cables have a Red identification sleeve.

NOTE: If you use either of these connections, you must add a BNC cable to bring the Black Burst/Gen Lock from the Camera Unit to your camera.

Telecast Breakout Cable

This special cable provided by Telecast has a 12-pin Hirose connector to the Camera Unit **Signal** jack on one end, and either four BNC connectors and an XLR at the other end (row #1 of Table 2) or a 9-pin D-type miniature connector, two BNCs, and an XLR (row #2 of Table 2).

- BNC: Video for connection to the Video Out on the camera
- BNC: Return Video between the camera and the Camera Unit
- XLR: Audio for connection to the Audio Out on the camera
- BNC or D-type: Intercom Trigger that connects to the headset
- BNC or D-type: Tally connection

The D-type connector is shown in Figure 10 on page 17 and its wiring in the breakout cable is shown in Table 11 on page 18.

Standard Sony 26-pin Connector Cable

This cable consists of a 26-pin standard connector at the camera and a 12-pin Hirose connector at the Camera Unit, with cable wiring standardized by each camera manufacturer as listed in rows 3 through 8 of Table 2. If this cable is used, no other cables are required for video, audio, Tally, return video, or headset mike trigger.

Camera	Cable Type	Telecast Part #
All	Breakout: Icom trigger and Tally on separate BNCs	CHCS-B0-B4-XF1
All	Breakout: Icom trigger and Tally on single DB-9	CHCS-B02-B2-XF1-D1
Hitachi	26-pin Standard (cam side) -12-pin Hirose (CH side)	CHCS-HIT-26P
Ikegami	26-pin Standard (cam side) -12-pin Hirose (CH side)	CHCS-IKE-26P
JVC	26-pin Standard (cam side) -12-pin Hirose (CH side)	CHCS-JVC-26P
Panasonic	26-pin Standard (cam side) -12-pin Hirose (CH side)	CHCS-PAN-26P
Thomson	26-pin Standard (cam side) -12-pin Hirose (CH side)	CHCS-PHL-26P
Sony	26-pin Standard (cam side) -12-pin Hirose (CH side)	CHCS-SON-26P

Table 2: Camera Unit Signal Cables

Remote Connections between the Camera and the Camera Unit (only)

The cables in Table 3 go from the 10-pin Remote connector on the Camera Unit to the 10-pin Remote connector on the camera.

NOTE: If you are using a remotely controlled PTZ head, use the appropriate remote cable from Table 4 rather than a cable from Table 3.

The Remote Cable carries the signals that came from the remote controller at the Base Station. The pinouts for the 10-pin Camera Unit Remote connector are described in Table 10 on page 18 and shown on the left in Figure 9 on page 16. Remote cables have a Yellow identification sleeve.

Find your Remote cable from Table 3 or Table 4 and connect it.

Camera	Model	Telecast Part #
Hitachi		CHCR-HIT-SK1-4-0
Ikegami	HK-388,387	CHCR-IKE-HK1-8-0
Ikegami	HL-59, HL-V7X, HK-398P, HK387P, HL-V59	CHCR-IKE-HK2-10-0
Ikegami	HL-45, HC-400	CHCR-IKE-HK3-12-0
Ikegami	HC-200/210/230/240/340, HL-43	CHCR-IKE-HC1-12-0
Ikegami	HL-45	CHCR-IKE-HK2-12-0
JVC	GY-DV550U	CHCR-JVC1-6-0
JVC	KY-D29	CHCR-JVC2-6-0
Panasonic		CHCR-PANA1-6-0
Sony	BVP5/50/7/70, BVW-200/300/400	CHCR-SON-BVP1-6-0
Sony	BVP-90,D600/DVW700/550/570	CHCR-SON-BVP2-6-0
Sony	HDW-700, HDC,BVP-750/900/950 (w/ RMB-9)	CHCR-SON-BVP2-8-0
Sony	HDW-700, HDC,BVP-750/900/950 (w/ RMB-150)	CHCR-SON-BVP3-8-0
Sony	DXC-537, DXC-D30/35/50 (w/ RM-M7G)	CHCR-SON-DXC1-10-0
Sony	DXC-D30/35/50 (w/ RCP-TX7)	CHCR-SON-DXC2-10-0

Table 3: Cables for Camera Unit Remote (no extra data)

Remote Connection between the Camera Unit, Camera, and Tilt Head

The Remote cables in Table 4 follow the same path from the 10-pin Hirose connector at the Camera Unit to the camera as do the cables in Table 3 on page 5, but also have a loose, 9-pin D-type output connector that provides control signals to a motorized PTZ head. The motion and camera control commands come from the remote controller connected to the Base Station by a cable selected from Table 5. These cables have a Yellow identification sleeve. The pinouts for the 9-pin D-type connector on the Base Station for the tilt head are shown in Table 8 on page 17.

Find your Remote cable and connect it.

Camera	Model	Telecast part #
Hitachi		CHCR-HIT-SK1-4-9
Ikegami	HK-388/387	CHCR-IKE-HK1-8-9
Ikegami	HL-59/V7X/V59, HK-398P/387P	CHCR-IKE-HK2-10-9
Ikegami	HL-45, HC-400	CHCR-IKE-HK3-12-9
Ikegami	HC-200/210/230/240/340, HL-43	CHCR-IKE-HC1-12-9
Ikegami	HL-45	CHCR-IKE-HC2-12-9
JVC	GY-DV550U	CHCR-JVC1-6-9
JVC	KY-D29	CHCR-JVC2-6-9
Panasonic		CHCR-PAN-AJ1-6-9
Sony	BVP5/50/7/70, BVW-200/300/400	CHCR-SON-BVP1-6-9
Sony	BVP-90/D600/DVW700/550/570	CHCR-SON-BVP2-6-9
Sony	HDW700, HDC, BVP-750/900/950 (RMP-9)	CHCR-SON-BVP2-8-9
Sony	HDW700, HDC, BVP-750/900/950 (RMB-150)	CHCR-SON-BVP3-8-9
Sony	DXC-537	CHCR-SON-DXC1-10-9
Sony	DXC-D30/35/50	CHCR-SON-DXC1-10-9

Table 4 : Cables for Camera Unit Remote with Data for Tilt Head Control

Base Station Cable to the Remote Controller

Connection to a camera manufacturer's remote controller at the Base Station is accomplished using a cable from Table 5. These cables connect the 9-pin D-type connector on the Base Station rear panel to the appropriate remote controller. The pinouts for this connector are shown in Figure 10 and Table 9 on page 17.

Find your Remote Controller cable and connect it.

Camera	RCP	Telecast part #
Hitachi	RU-Z1, RC-Z1, RC-Z11, RU-Z22, RC-Z2A, RX-Z21A	CHBR-HIT-SK1-4
Ikegami	OCP or MCP-377/388,RCP-50	CHBR-IKE-HK1-8
Ikegami	RM-10/11, RS-11, RCP-50,	CHBR-IKE-HK2-10
Ikegami	BS-40,MA-200/230, MRU-230,RCU-230/240	CHBR-IKE-HK3-12
JVC	RM-LP55U/57U	CHBR-JVC1-6
JVC	RM-LP35/37/38/80U	CHBR-JVC2-6
Panasonic	AQ-EC1	CHBR-PAN-AJ1-6
Panasonic	AJ-EC3	CHBR-PAN-AJ2-10
Sony	RMP-3, RMP-9 (all except BVP90/90P)	CHBR-SON-BVP-1-6
Sony	RMP-9 (w/ BVP90/90P)	CHBR- SON-BVP-2-6
Sony	RMB-150	CHBR- SON-BVP-3-8
Sony	RM-M7G	CHBR- SON-DXC1-10
Sony	RCP-TX7	CHBR- SON-DXC2-10

Table 5: Cables between Base Station and Remote Controller

Camera Unit Panels

Front Panel: Indicators and Switches

The Camera Unit Front Panel in Figure 4 faces the camera operator. The Camera Unit Connector Panel in Figure 5 on page 8 is on the side remote from the operator and holds the connections to the camera as well as the fiber to the Base Station.

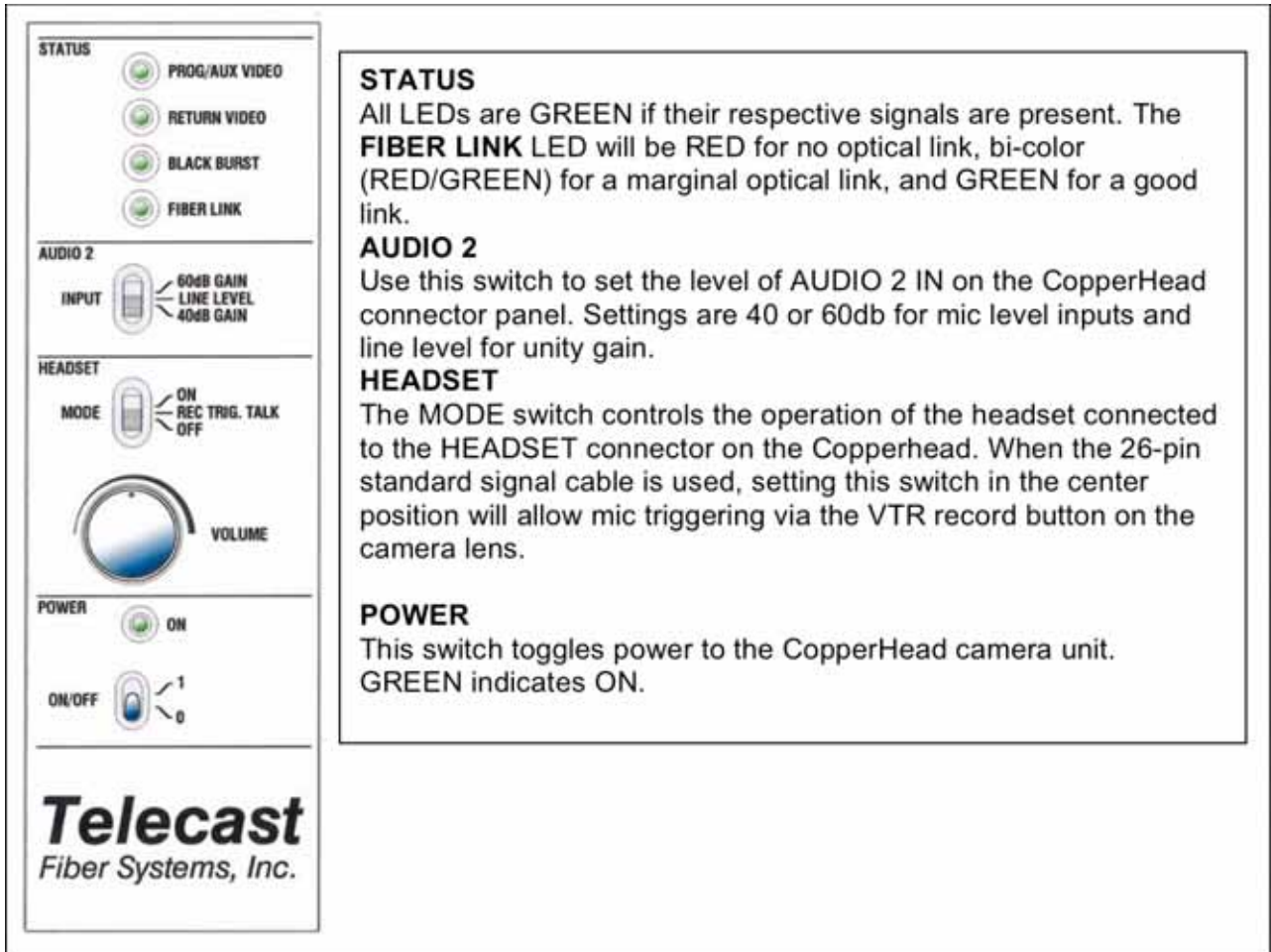

Figure 4: Camera Unit, Front Panel

Connector Panel: Cable and Fiber Connections

The Camera Unit Connector Panel shown in Figure 5 faces outward from the camera operator and holds the connectors to the camera and operator accessories as well as the fiber connector to the Base Station.

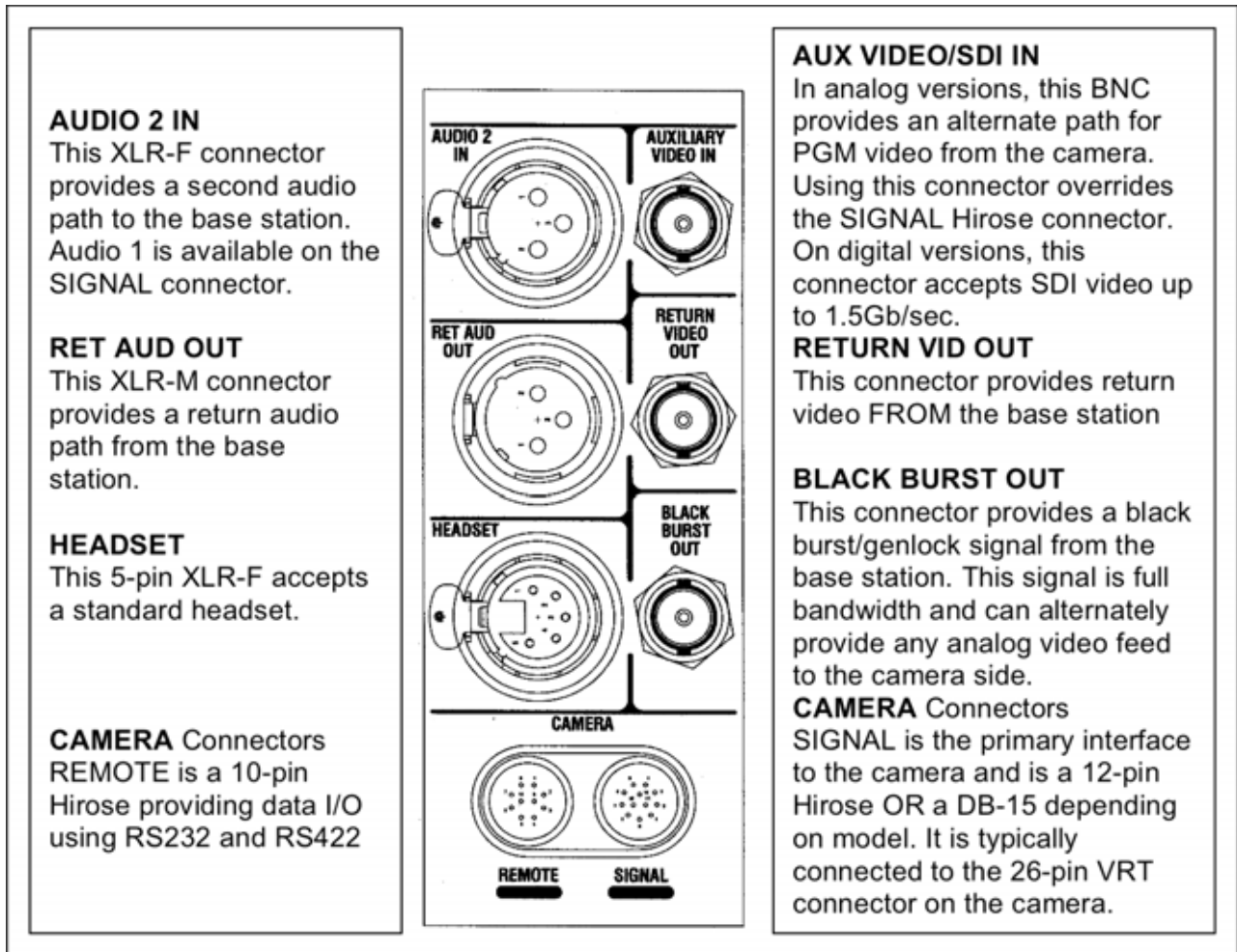

Figure 5: Camera Unit, Connector Panel

Base Station, Front Panel

The Base Station is contained in a 19-inch chassis with removable rack-mounting flanges. The front panel is shown in Figure 6. This panel holds system status LEDs and the following two switches:

- **POWER:** on or off
- **ALARM:** on or off

The Rear Panel shown in Figure 7 on page 10 holds all the connectors to supporting equipment inputs and outputs and the DC power jack.

Front Panel

The panel has four groupings of indicators and controls: Video, Control, Audio, and System.

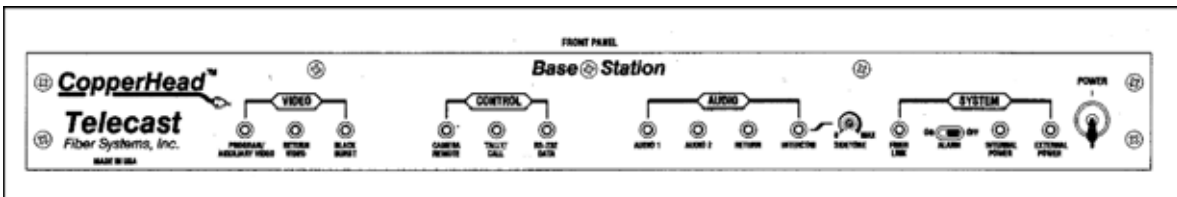

Figure 6: Base Station, Front Panel

The LEDs illuminate when their respective signals are present except for FIBER LINK, which will be RED for no optical link, bi-color (RED/GREEN) for a marginal optical link, and GREEN for a good link.

INTERNAL POWER: illuminates Green when external power is charging the internal battery. This LED changes to RED when the Base Station backup battery is powering the unit and the Base Station POWER switch is ON, an indication that main 12-18 VDC INPUT POWER has failed and the Base Station is operating from its battery.

NOTE: Battery life at the Base Station under full operation is 1/2-hour.
Recharging time from full discharge is 12 hours.

Base Station, Rear Panel

The rear panel shown in Figure 7 supports all the electrical I/O interconnections to ancillary equipment and the OPTICAL FIBER connector that goes to the Camera Unit.

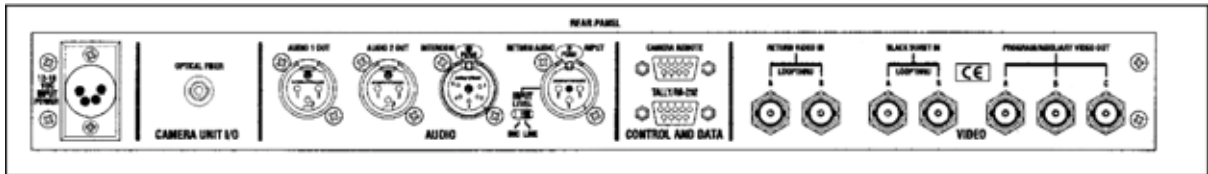

Figure 7: Base Station, Rear Panel

12-18 VDC Input Power: An external 12 to 18 VDC external power supply is connected at this port. The pinouts for this 4-pin XLR are shown in Table 15 on page 19. This power line does not require a fuse; the Base Station has self-resetting overload protection.

Camera Unit I/O: This is the ST fiber connector. On analog units there is one and on digital units there are two. Always put the attached protective cap over this connector whenever a fiber cable is not connected here.

AUDIO: The following three connectors are XLR types that are wired to the industry standard shown in Table 12 on page 18.

Audio 1 Out: camera program audio output.

Audio 2 Out: signal from the Audio 2 In connector at the Camera Unit.

Return Audio In and Input Level: this can be a mic or line level source return back to the camera. Use the slide switch to select either MIC or LINE level input.

INTERCOM: Connect a 4-wire intercom jack at this port. The port pinouts are shown in Table 14 on page 19.

CAMERA REMOTE

Camera control interface and digital data are transmitted via this 9-pin D-type connector. The pinouts for this connector are given in Table 9 on page 17.

CONTROL AND DATA

The pinouts for this DB-9 connector are given in Table 8 on page 17. Contact closure at the Camera Unit is established by an isolated, normally open, dry contact. This closure is enabled by grounding pin 6 on this connector. The RS-

232 data path is also available on this connector to support optional controllable devices such as a pan tilt head or a zoom lens.

On CopperHead “CINE” versions, there is an additional DB-15 connector for the four line level return audio paths to the camera. See table 9 for the pinouts of this connector.

VIDEO

The video connectors in this grouping are all standard BNC types. Depending on Copperhead version, there will be varying numbers of connectors.

All unused BNCs should be 75 Ohm terminated.

Return Video In: A return video source to the camera is connected to Loop-thru BNC connectors A or B.

Black Burst In: The Black Burst signal, also referred to as Gen Lock or Sync, is connected to either Loop-thru BNC connector A or B. As a full bandwidth video path, this can be used to send any analog video back to the camera.

Program/Auxiliary Video Out: These three BNC connectors are from the Auxiliary Video In port on the Camera Unit if that port is active. If a signal is not detected on that port, BNC's A, B and C provide program video from the camera received over the 12-pin Hirose Signal connection.

SDI Video out: In digital CopperHeads, two BNC's will provide the serial digital video output at data rates up to 1.5 Gb/sec uncompressed.

Component Video out: In Y-U-V CopperHeads, these three BNC's provide digital component outputs of the SDI PGM signal. All other Video outputs remain present.

Attaching the Base Station Rack Mount Flanges

The flange adapters can be attached to the Base Station for rack use with two #10 Phillips head screws at each flange, as shown in Figure 8.

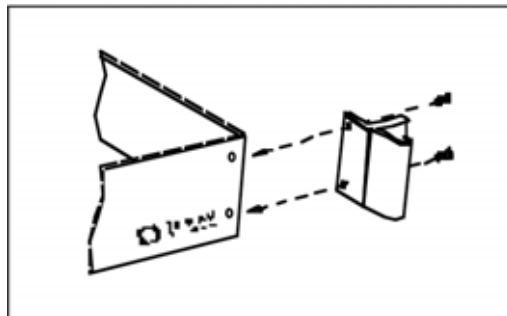

Figure 8: Attaching the Rack Mount Flanges

Power Systems

Camera Unit

The power source for operation of the Camera Unit is from the 12 VDC camera battery pack mounted to the Camera Unit. Power consumption is 7.25 watts. Alternately, a battery plate adapter can be used to power the Copperhead and camera with a 12-18VDC external power supply via a 4-pin XLR connector.

Base Station

Base Station power comes from an external supply providing 12 to 18 VDC derived from a line source, or from a camera or automobile battery. Power consumption is 9.75 watts. Internal DC/DC converters regulate and distribute power to the chassis circuits. External power is input via a 4-pin XLR connector with pinouts listed in Table 15 on page 19.

If the external source fails, the CopperHead draws power for about 1/2-hour from an internal backup battery.

NOTE: Although the CopperHead will function properly at a supply voltage as low as 12 VDC, keep this voltage above 13.8 VDC to assure continuous trickle charge of the internal battery.

External Power Loss Alarms

There are both audible (buzzer) and visible (internal power LED) alarms if external power is lost to the Base Station. If the alarm switch is on, a buzzer sounds whenever external power is lost and the system is operating on temporary battery power. You can disable the audible alarm by moving the switch to off.

If the audible alarm is disabled prior to operation, the front panel Internal Power LED is the only indication that power is being drawn from the limited power internal battery.

Optical Fiber

WARNING: Never look directly into the end of the optical fiber while either end of the system is operating. Eye damage can result.

Fiber Cable Runs

CopperHead can be used with single or multimode fiber. The single mode fiber recommended by Telecast enables longer cable runs than multi-mode fiber and is mandatory for HD video applications. The approximate ranges for the fiber runs are:

Single mode: 5 km plus 20 dB allowed for connector losses

Multimode: 2 km plus 15 dB allowed for connector losses

System options are available to provide longer cable runs; contact Telecast for information.

CopperHead can be connected into your existing fiber system so you can locate a camera at a long distance from the system base station, within the above constraints.

A number of optical fiber configurations are available from Telecast as listed in Table 6 on page 15. The fiber is wound onto Telecast's portable Ox-Frame reel.

Connectors

The base station comes equipped standard with one or two ST type connectors, depending upon configuration.

The analog camera unit has one ST.

The digital Camera unit has two ST's, and HDLC, or an MX mini-expanded beam connector. MX is recommended for multi-fiber CopperHeads.

Use caps when the connectors are not in use.



Figure 9: Optical connector types

CopperHead Operation

System Setup

1. Check that the cables interconnecting the camera, Camera Unit, and support equipment are all in place.
2. Set the headset switch on the Camera Unit to the desired mode. You can switch this function to ON, OFF, or REC TRIG.TALK in which case the camera's VTR Record button will activate the intercom microphone. Using this mode requires a Camera Unit connection via the 26-pin standard connector.
3. Check that the power to the Camera Unit, camera, and Base Station are all off.
4. If you have connected a microphone to the audio 2 input on the Camera Unit, set the input switch to the proper gain level for that microphone.
5. Inspect and clean both fiber ends (ferrules) with clean, dry compressed air or with Kim-Wipes that have been wet with isopropyl alcohol. Fingerprints or other dirt on the optical connector end surfaces will reduce the optical signal level on the fiber.
6. Connect the fiber at the Camera Unit and prepare to run it to the Base Station.

CAUTION: Before taking the next step, be sure that the ST fiber port on the Camera Unit is connected to a fiber or has a cap on it. Never look directly into the end of the optical fiber or into a fiber connector while either end of the system is operating. Eye damage can result.

7. Connect the fiber at the Base Station. Do not leave the fiber hanging without a cap.
8. Connect the remote controller and all other input and output cables at the Base Station. Remember, the cable to the remote controller must be a Telecast part taken from Table 5 on page 6.
9. Make sure that an external power supply is connected to the 12-18 VDC power input connector at the rear of the Base Station.

NOTE: The turn-on sequence is not critical for most camera types. However, if you cannot establish communication between the remote controller and the camera, use the following sequence.

10. Be sure that the power to the camera, Base Station, and Camera Unit are all off.
11. Slide the power switch on the Camera Unit to on. The adjacent LED illuminates.
12. Switch the camera power ON.

13. Pull on the base station power switch to release its lock and lift it to turn it on. The **fiber link** and **external power** LEDs at the Base Station are now illuminated Green.
14. Set the audible alarm switch on or off.

Other LEDs on the Base Station front panel are illuminated depending on the connections that you have made. For example, if a connected signal light is not on such as a sync signal connected to the black burst in port on the rear panel and the black burst LED is not illuminated, examine your cables and connections, and check that a signal is being generated by your sync source.

The CopperHead is now ready for use.

Shutting down your CopperHead system

1. The camera power may be turned off at any time.
2. To avoid the possibility of looking directly into an active fiber optic port or cable, turn both the Camera Unit and the Base Station off before disconnecting the fiber from either point.
3. Never look directly into the end of the optical fiber or into a fiber connector while either end of the system is operating. Eye damage can result.
4. Cap the connector receptacles and fiber ferrules.
5. Respool the fiber onto the reel.

NOTE: Evenly spread the cable over the reel's hub to avoid cable spillage or over-wrapping when retrieving.

Accessory List

The following fiber optic accessories are available from Telecast:

- Optical power meter kit
- Cable repair kit
- Short fiber cable to verify operation before deployment
- Prefabricated cables built to custom lengths
- Portable fiber reels

Repair

Call the Telecast Service Department at 508-754-4858 for assistance when troubleshooting or reconfiguring the CopperHead system. To return a unit for you must obtain a return material authorization (RMA) number from Telecast Service.

Appendix

Fiber Cables

The representative cables in Table 6 are available from Telecast. Other lengths or connector types can be ordered on a “Special Order” basis.

Part Number	Length	Fibers/Type	Reel Size
CASM-5T1S-ST	500 Feet (152m)	1- Singlemode	Small
CASM-5T1M-ST	500 Feet (152m)	1- Multimode	Small
CASM-5T2S-MX	500 Feet (152m)	2- Singlemode	Small
CASM-5T2M-MX	500 Feet (152m)	2- Multimode	Small
CASM-5T4S-MX	500 Feet (152m)	4- Singlemode	Small
CASM-5T4M-MX	500 Feet (152m)	4- Multimode	Small
CAMD-10T1S-ST	1000 Feet (305m)	1- Singlemode	Medium
CAMD-10T1M-ST	1000 Feet (305m)	1- Multimode	Medium
CAMD-10T2S-MX	1000 Feet (305m)	2- Singlemode	Medium
CAMD-10T2M-MX	1000 Feet (305m)	2- Multimode	Medium
CAMD-10T4S-MX	1000 Feet (305m)	4- Singlemode	Medium
CAMD-10T4M-MX	1000 Feet (305m)	4- Multimode	Medium
CAXL-20T1S-ST	2000 Feet (610m)	1- Singlemode	X-Large
CAXL-20T1M-ST	2000 Feet (610m)	1- Multimode	X-Large
CAXL-20T2S-MX	2000 Feet (610m)	2- Singlemode	X-Large
CAXL-20T2M-MX	2000 Feet (610m)	2- Multimode	X-Large
CAXL-20T4S-MX	2000 Feet (610m)	4- Singlemode	X-Large
CAXL-20T4M-MX	2000 Feet (610m)	4- Multimode	X-Large

Table 6: Fiber Selections

Connector Drawings and Pinouts

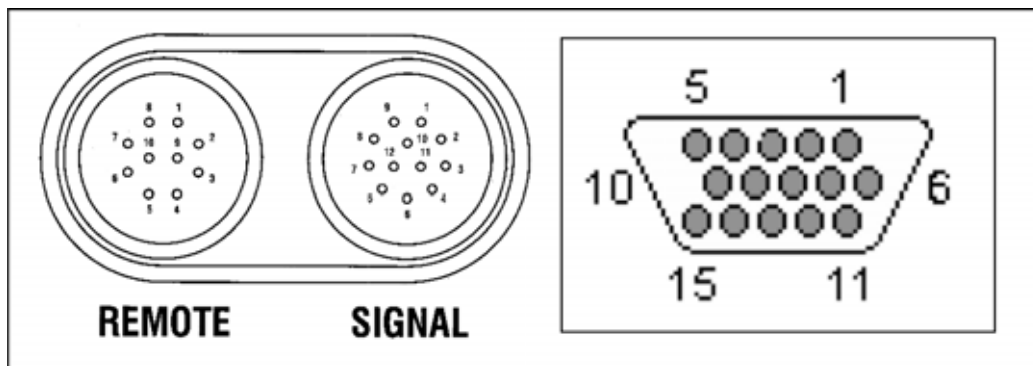

Figure 10: Left: 10-Pin Hirose Remote Right: 12-pin Hirose Signal or DB-15

Pin No.	Function
1	+12 VDC Input Power (& CCU Format Select bias)
2	12 VDC Input Power Ground
3	+ CCU Input or Bi-directional CCU I/O
4	RS-232 Data Input
5	CCU Format Select
6	- CCU Output
7	Ground for CCU shields, RS-232 Data Common
8	RS-232 Data Output
9	- CCU Input
10	+ CCU Output

Table 7: 10-Pin Hirose Remote Connector on Camera Unit

Pin No.	Function
1	Chassis Ground
2	Return Video Output Signal
3	Return Video Output Ground (shield)
4	+ Camera Audio Input
5	Camera Audio Input Ground (shield)
6	- Camera Audio Input
7	Camera Video Input Ground (shield)
8	Camera Video Input Signal
9	+12V Out
10	Headset MIC Trigger Signal
11	Tally Output Contact A
12	Tally Output Contact B

Table 8: 12-Pin Hirose Signal Connector on camera unit

Pin No.	Function
1	Return Video Output
2	Chassis GND
3	Y Input
4	R-Y Input
5	B-Y Input
6	Return Video Output GND
7	Camera Audio Input (-)
8	Camera Audio Input (+)
9	Headset Mic Trigger
10	Cam PGM Video In
11	Tally Output Contact A
12	CAMERA AUDIO IN GND
13	Genlock Out
14	+12 VDC out
15	Cam PGM Video In GND

Table 9: DB-15 Signal Connector on camera unit

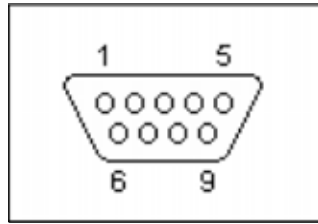

Figure 11: 9-Pin D-type Connector

Pin No.	Function
1	Unused
2	232 Data Output
3	232 Data Input
4	Unused
5	GND (232 Data common)
6	Tally Input - Signal
7	Tally Input - GND
8	Unused
9	Unused

Table 10 : Tally/RS-232 Data Connector at Base Station

Pin No.	Function
1	- CCU Input
2	CCU Format Select
3	CCU Ground (Shield)
4	+12 VDC Bias for CCU Format Select
5	- CCU Output
6	+ CCU Input or Bi-directional CCU I/O
7	- 12 VDC CCU Power Ground
8	+12 VDC CCU Power
9	+ CCU Output

Table 11: Camera Remote Pinouts on Base Station

Pin No.	Function
1	Ground
2	- Balanced I/O
3	+ Balanced I/O

Table 12: Audio return XLR Pinout

Pin No.	Function
1	MIC Ground (shield)
2	+ MIC Input
3	- Earphone Output Ground
4	+ Earphone Output
5	+ Earphone Output

Table 13: Headset Pinout, Camera Unit

Pin No.	Function
1	Ground
2	+ Input
3	- Input
4	- Output
5	+ Output

Table 14: Intercom Pinout, Base Station

Pin No.	Function
1	Ground
2	Unused
3	Unused
4	+ Power VDC

Table 15: XLR-4 Power Connector Pinout, Base Station

Audio Connectors for Cine Version

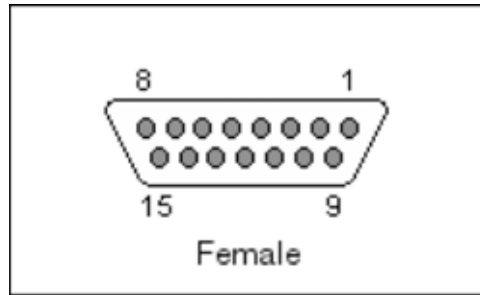

Figure 12: DB-15 Connector, Base Station

Pin No.	Function
1	Audio Channel 1 IN (+)
2	Unused
3	Audio Channel 2 IN (+)
4	Unused
5	Audio Channel 3 IN (+)
6	Unused
7	Audio Channel 4 IN (+)
8	Unused
9	Audio Channel 1 IN (-)
10	Unused
11	Audio Channel 2 IN (-)
12	Unused
13	Audio Channel 3 IN (-)
14	Unused
15	Audio Channel 4 IN (-)
CASE	Ground

Table 16: DB-15 F Audio Connector, Base Station

Pin No.	Function
1	Ground
2	Channel A/C (-) OUT
3	Channel A/C (+) OUT
4	Channel B/D (-) OUT
5	Channel B/D (+) OUT

Table 17: XLR 5-Pin audio out, Camera end
Top 5-pin= Channels A/B, Bottom = C/D

Other Cable Pin-outs

Pin No.	Function
1	Unused
2	Headset MIC Trigger Ground
3	Unused
4	Headset MIC Trigger
5	Unused
6	Tally Output Contact A
7	Unused
8	Tally Output Contact B
9	Chassis Ground

Table 18: DB-9 Connector on CHCS Breakout Cable

How to handle “Tally”

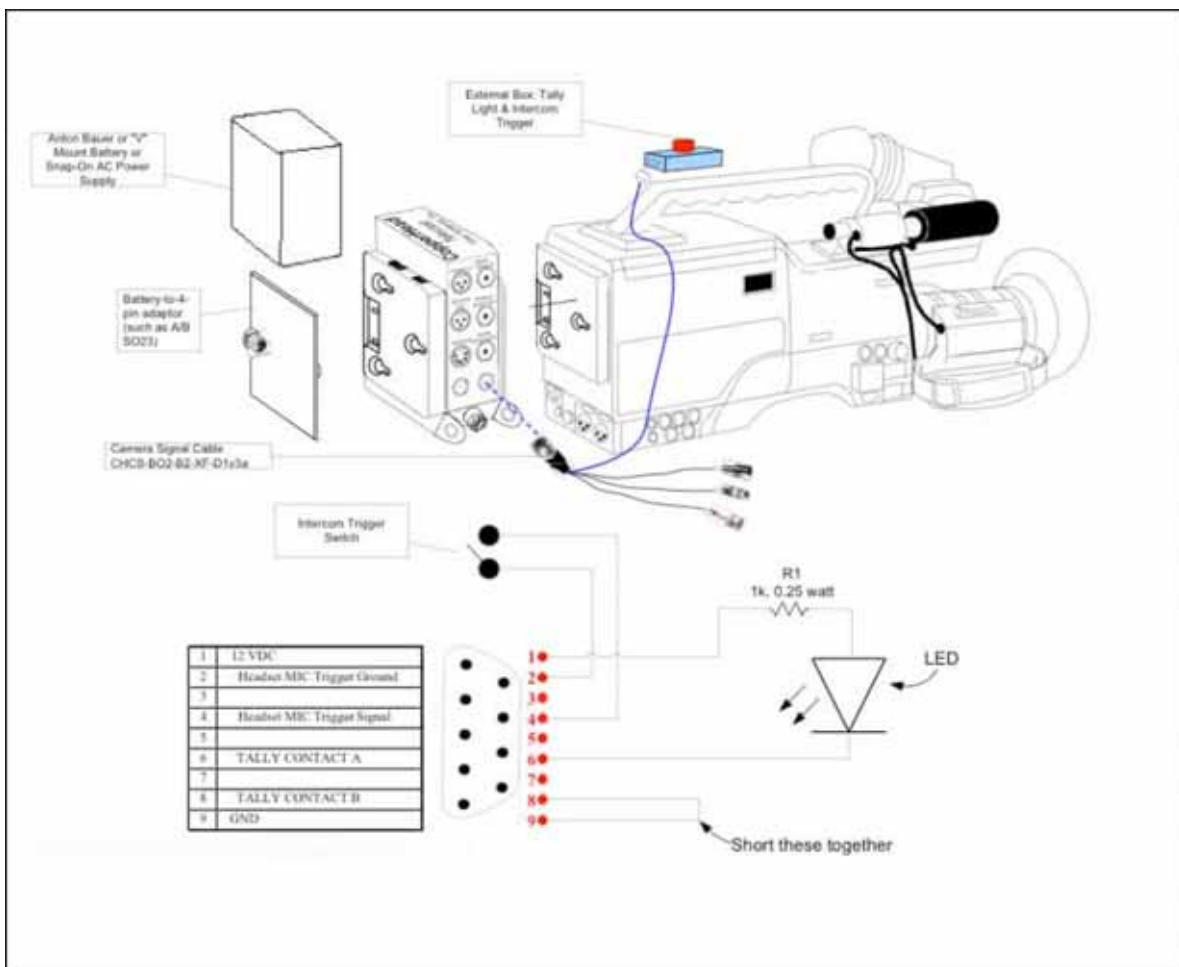

Figure 13: Simple LED Tally wiring diagram

Using CopperHead with Power Plus

The Power Plus, when used in conjunction with the Telecast HDX, allows you to use SMPTE hybrid cable as the fiber path and power source for your camera system. As shown in the next diagram, the Power Plus attached to the rear of the Copperhead and then connects to the HDX via standard SMPTE hybrid cable. Then, two ST jumpers attach the HDX to the ST connectors on the rear of the CopperHead base station. On the Camera side, power passes through the Copperhead to the camera and the optics go through a short fiber jumper cable.

In addition to powering the camera end of the system, there is an additional 12-24 VDC output on the Power Plus for lights or a PTZ head.

Consult the Power Plus and HDX manuals for further details.

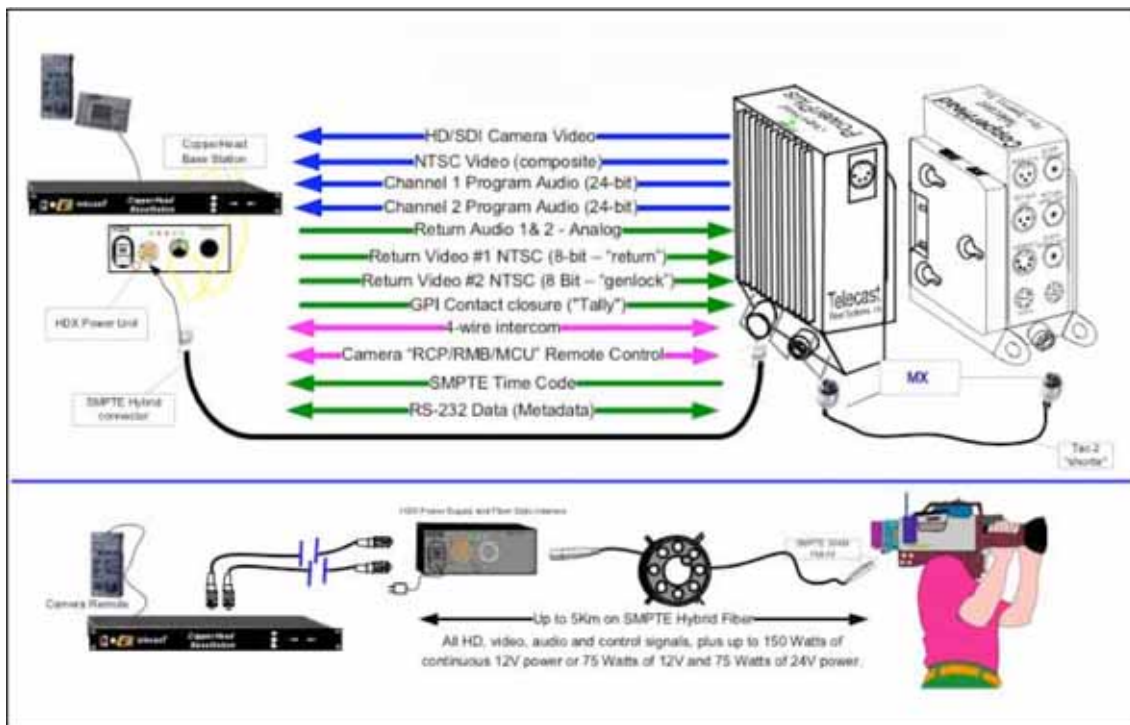

Figure 13: Using the Power Plus with CopperHead

Specifications

Environment

Dimensions-CA(L x W x H)	5.2" x 6.2" x 2.2"
Weight -Camera end	1.5 lb.
Dimensions-BS(L x W x H)	8.7" x 3.9" x 2"
Weight -Base station end	5 lb.
Temperature Range	-25 C to +55 C
Humidity Range	0 to 95% non-condensing

Connectors

Electrical (Data/Audio)	DB-9, DB-15, HD DB-15 Female, XLR
Video (analog/SDI)	BNC
Optical	As configured (ST/HDLC/MX)

Input Voltage

12-18VDC

Power Consumption

Base Station unit	Less than 10 Watts
Camera end unit	Less than 7 Watts

Video, Digital

Interface	SMPTE 259M, 292M
SDI Rates Supported	19.4 Mbps to 1.5 Gbps, Uncompressed
Input Coaxial Equalization	Up to 100 meters
Input Level	800 mV (peak to peak)
Input/Output Impedance	75 Ohms
Bit-Error Rate (@ -22 dBm)	10-12
Jitter (pathological pattern)	<0.2 UI
Rise/Fall Times	<270 ps

Video, Analog

Interface	RS170, NTSC, PAL, SECAM
Input/Output Level	1 Vp-p, 75 Ohms
Frequency Response	
30Hz-5MHz	±0.15 dB
-3dB point, min.	>10MHz
Signal to Noise Ratio, weighted	>72 dB
Differential gain	<1%
Differential phase	<0.5°
Line Time Distortion	<0.5 IRE
Chrominance-Luminance Intermod.	<0.5%

Audio

Input/Output Impedance	10 kΩ/30 Ω
Frequency Response	±0.2 dB, 20Hz to 20kHz
Audio Signal to Noise Ratio	> 90 dB, A-weighted
Total Harmonic Distortion	< 0.1%

Data/Auxiliary

RS422 or RS4851	0 to 1 Mbaud
RS232	0 to 150 kbaud
Jitter	33 nsec
Contact Closure	Normally Open, Form 1 SPST

Electro-Optical

Operating wavelengths	1310/1550
TX output power (std./optional)	-6 dBm/0 dBm
RX Sensitivity (Main)	-20 dBm
RX Sensitivity (HD/SDI)	-22 dBm/-30 dBm
Fiber Type	Single Mode (SM) 9/125 or multimode (MM) 60/125
Attenuation Factor	SM= 0.5 dB/km @ 1300 nm MM = 1.0 dB/km
Recommended Distance	SM = 5 km, MM = 2 km Optional DFB >30 km

Warranty

LIMITED WARRANTY STATEMENT

Telecast Fiber Systems, Inc. ("Telecast") expressly warrants to Buyer that the Products supplied shall be free from defects in materials and workmanship for a period of 12 months following the date the Products are delivered to Buyer (the "Warranty Period"). Telecast's liability under this limited warranty shall be limited, at its option, to providing refund of purchase price for Products, or replacing or repairing Products shown to be defective either in materials or workmanship. Buyer's sole and exclusive remedy for breach of warranty shall be such refund, replacement or repair.

A claim of defect in materials or workmanship in any Product shall be allowed only when it is submitted in writing to Telecast Fiber Systems, Inc. within seven days after discovery of the defect, and in any event within the Warranty Period. No claim shall be allowed in respect of any Product which has been altered, neglected, damaged or stored in any manner which adversely affects it. In order to obtain service under the terms of this warranty, Distributor's customer or Distributor must notify Telecast of the defect prior to the expiration of the applicable warranty period and obtain a Return Authorization Number from Telecast. In no event may products be returned to Telecast or to Distributor for warranty service without having obtained from Telecast a Return Authorization Number.

This limited warranty applies only to new and unused Products delivered to Buyers located within the United States of America, or to international Buyers if sold through an authorized Distributor organization, and shall not extend to any equipment not manufactured by Telecast Fiber Systems, Inc., even though such equipment may be sold or operated with the Products. In addition, this limited warranty shall be void and of no further force or effect whatsoever if the Product is repaired or modified by any person other than an authorized representative of Telecast Fiber Systems, Inc. without the consent of Telecast Fiber Systems, Inc. This warranty shall not apply to any defect, failure or damage caused by improper use or inadequate maintenance and care. Nor shall this warranty apply to any damage caused in whole or in part by attempts by personnel other than Telecast's personnel, as approved in advance in accordance with the foregoing provisions, to open, install, repair, or service the Product; nor to damage resulting from improper connection with incompatible equipment; nor to damage to a unit which has been modified by personnel other than Telecast personnel.

Products returned to Telecast for warranty service shall be shipped, freight prepaid to Telecast. Telecast will return the repaired product or ship a replacement, freight prepaid, to either Distributor or Distributor's customer, as requested by Distributor's customer, at a location within the United States or, at Telecast's option, to Distributor's location in the case of international sales.

This limited warranty shall also apply to Products that replace defective Products and Products that have been repaired by authorized representatives of Telecast Fiber Systems, Inc., but only for the original Warranty Period. The Warranty Period shall not be extended by reason of defect, or any period of time during which the Product is not available to Buyer because of defects or repairs, without the express written consent of Telecast Fiber Systems, Inc.

EXCEPT FOR THE EXPRESS LIMITED WARRANTY AGAINST DEFECTS IN MATERIALS AND WORKMANSHIP CONTAINED HEREIN, TELECAST FIBER SYSTEMS, INC. MAKES NO WARRANTY OF ANY KIND WHATSOEVER, EXPRESS OR IMPLIED, AND ALL WARRANTIES OF MERCHANTABILITY, FITNESS FOR A PARTICULAR PURPOSE, AND OTHER WARRANTIES OF WHATEVER KIND ARE HEREBY DISCLAIMED BY TELECAST FIBER SYSTEMS, INC. THIS LIMITED WARRANTY SETS FORTH EXCLUSIVELY ALL OF TELECAST FIBER SYSTEMS, INC.'S LIABILITY IN CONTRACT OR OTHERWISE IN THE EVENT OF A DEFECTIVE PRODUCT.

WITHOUT LIMITATION ON THE FOREGOING, TELECAST FIBER SYSTEMS, INC. EXPRESSLY DISCLAIMS ANY LIABILITY WHATSOEVER FOR ANY DAMAGES INCURRED DIRECTLY OR INDIRECTLY IN CONNECTION WITH THE SALE OR USE OF, OR OTHERWISE IN CONNECTION WITH, THE PRODUCT, INCLUDING WITHOUT LIMITATION, LOSS OF PROFITS AND SPECIAL, INCIDENTAL OR CONSEQUENTIAL DAMAGES, WHETHER CAUSED BY NEGLIGENCE OR OTHERWISE, REGARDLESS WHETHER TELECAST HAS BEEN GIVEN ADVANCE NOTICE OF THE POSSIBILITY THEREOF.

THIS WARRANTY IS GIVEN BY TELECAST IN LIEU OF ANY OTHER WARRANTY EXPRESSED OR IMPLIED.