

DCP-1721

DESCRIPTION

The DCP-1721 is a non-intrusive probe intended for the quality control of digital audio signals used in a broadcast environment. It integrates several advanced features such as signal presence detection, validation and real-time analysis. It is specifically adapted to perform with different critical audio contents and signal paths. The probe includes a full set of embedded profiles, editable according to the need. Thresholds of sensitivity and number of occurrences are completely configurable by the user to precisely match parameter measurement requirements and to prevent unnecessary alarms. The probe generates alarm reports and telemetry information. It also provides special remote monitoring features such as real-time audio streaming for transmission over IP. The bit rate can be easily configured to function with available network bandwidth. The probe also generates remote audio metering data, providing real-time audio level and phase metering for on-screen display.

The DCP-1721 can be used in two modes: non-intrusive, or DA mode. Each channel includes a balanced input with loop and three outputs. The DCP-1721 requires a Densité frame with an Ethernet controller, and uses a single-width rear connector panel.

FEATURES

- AES3 or AES3-id input with loop and outputs
- AES carrier and channel status alarms
- Overload, maximum, minimum and no-signal alarms
- Phase, imbalance and stereo width alarms
- Lack of dynamics and audio slicing detection
- Adjustable thresholds
- Versatile granularity range from 1 s to 24 h
- Embedded and user profiles
- Audio streaming for transmission over IP
- Audio metering data for audio levels and phase over IP
- Remote monitoring
- Settings and adjustments through frame control panel or remotely
- Status LED and alarms remote reporting
- Easy to install audio connectors
- Provides output to Monitoring Switching Bridge option (MSB-1121)

TYPICAL APPLICATIONS

- Real time quality control and alarms
- Local and remote controls
- Centralized broadcasting

FUNCTIONAL BLOCK DIAGRAM

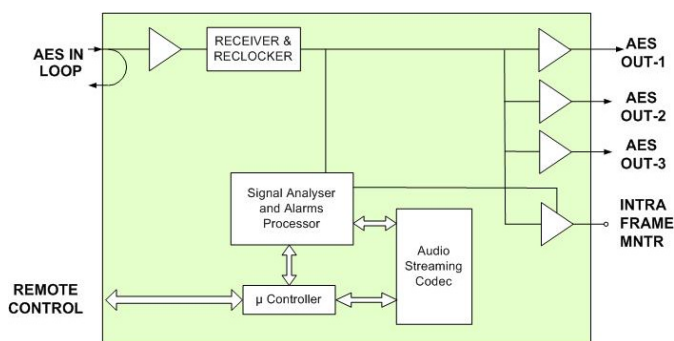

SPECIFICATIONS

OUTPUTS (3)	AES3	AES3-ID
Level:	4 Vpp	1 Vpp
Impedance:	110 Ω	75 Ω
Rise & fall time:	20 ns	33 ns
Return loss:		15 dB @ 12.244 MHz

AES3 INPUTS

Level:	0.2 to 7 Vpp
Impedance:	balanced passive loop-through (requires ext. load), jumper selectable internal 110 Ω load
Equalization:	100 m (330')

AES3-ID INPUTS

Level:	0.2 to 2 Vpp
Impedance:	unbalanced passive loop-through (requires ext. load), jumper selectable internal 75 Ω load.
Return loss:	15 dB @ 12.244 MHz
Equalization:	300 m (1000')

PROCESSING PERFORMANCE

Sampling:	28 to 100 kHz
Processing delay:	550ns @ 48 kHz (+2.7%/FS)

POWER

DCP-1721-75:	1.4 W
DCP-1721-110:	1.5 W

DCP-1721 Digital Audio Control Probe Guide to Installation and Operation

INSTALLATION

Make sure the following items have been shipped with your DCP-1721. If any of the following items are missing, contact your distributor or Miranda Technologies Inc.

- * DCP-1721 AES Digital Audio Probe
- * DCP-1721 Rear Panel (one of the following):
 - o DCP-1721-SRP-75 AES3-id, 75 O
 - o DCP-1721-SRP-110 AES3, 110 O

The DCP-1721 and its associated rear connector rear panel must be mounted in a DENSITÉ frame. It is not necessary to switch off the frame's power when installing or removing the DCP-1721. See the DENSITÉ Frame manual for detailed instructions for installing cards and their associated rear panels.

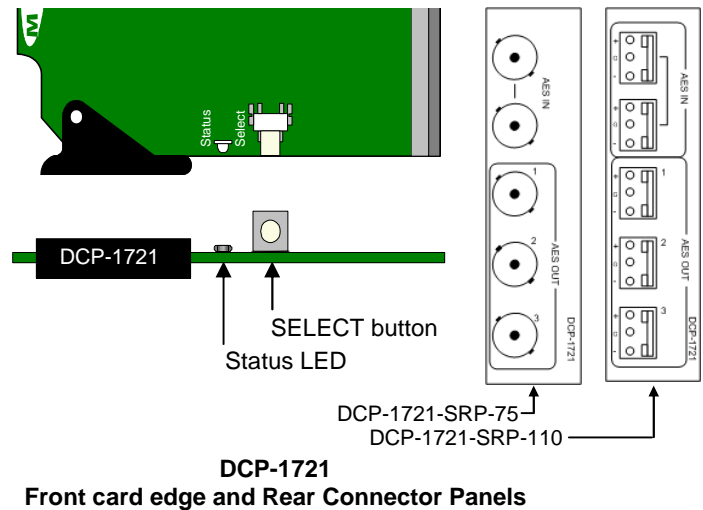

OPERATION

Overview

The DENSITÉ frame incorporates a controller card, located in the center of the frame. The controller handles error reporting and local and remote control for all cards installed in the frame. It is equipped with a display and a control panel. The display and control panel are assigned to the card in the frame whose SELECT button has been pushed.

The primary control interface for the DCP-1721 is Miranda's iControl system. The iControl interface is explained in detail beginning on the next page.

Local User Interface – status reporting and control

The status monitor LED is located on the front card-edge of the DCP-1721 module, and is visible through the front access door of the DENSITÉ frame.

The DCP-1721 STATUS LED is green under normal operation. When the DCP-1721 detects an error, the STATUS LED turns yellow or red. Pushing the SELECT button will cause the STATUS LED to flash yellow, and the

card identification and the current status message will be shown on the controller card's display. The STATUS LED will revert to its normal state upon a second push of the button, or after a short delay. The color of the status LED and the reporting of errors are user-configurable via the Log Config panel of the iControl interface. See page 13 for details.

After pressing the SELECT button on the DCP-1721 card, use the keys on the local control panel (described in the Controller card manual) to step through the displayed status messages. The message structure is shown below.

Here is an example of a status message for an overload detected on channel 2:

D	C	P	-	1	7	2	1								
O	V	E	R	L	O	A	D	2							

See page 13 for a detailed explanation of how to use the local control panel and menu to configure the DCP-1721, as an alternative to configuration via iControl.

Status Message Structure

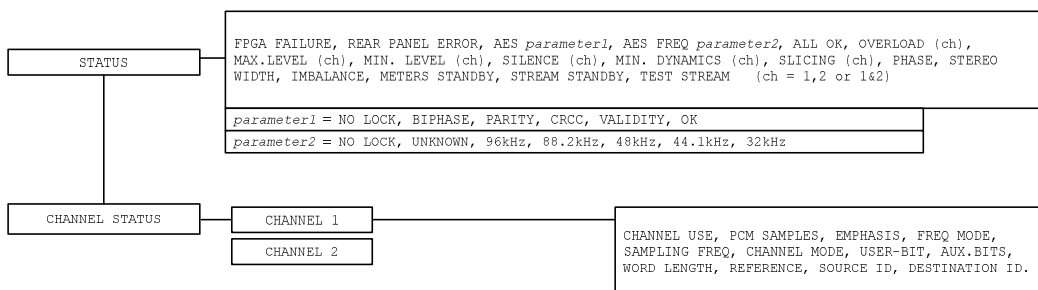

iCONTROL INTERFACE

The operation of the DCP-1721 is controlled using Miranda's iControl system. This manual describes the control panels associated with the DCP-1721 and their use. Please consult the iControl User's Guide for information about setting up and operating iControl.

In iControl Navigator or iControl Websites, double-click on the DCP-1721 icon to open the control panel.

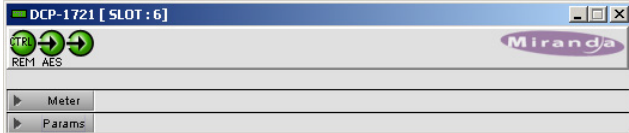

The control panel has three sections:

Status Bar: at the top of the panel, shows status icons for several key items, and text messages describing detected errors. A complete description of the status bar begins below.

Meter: shows an Audio Meter monitoring the program, and status messages associated with the data stream being monitored by this probe. Click on the box with the arrow icon to open or close this section. A complete description of the Meter begins on this page.

Params: gives access to all controls and adjustments associated with this probe. Click on the box with the arrow icon to open or close this section. A complete description of how to set up the probe using the Params section begins on page 4.

These sections are described in more detail below.

Status Bar

The status bar provides a continuous update of the status of the DCP-1721. The status bar includes three sections:

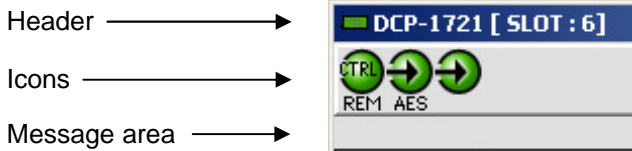

The **header** gives the product name (by default) or user-assigned name, and identifies the slot in which it is installed in its Densité frame. At the left is a status icon whose color shows the overall status of the probe:

- Green = OK
- Yellow = warning
- Red = error

The three **icons** monitor some specific aspects of the DCP-1721's operation:

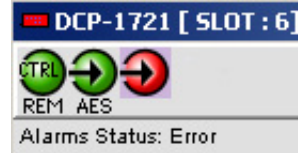

(a) (b) (c)

- (a) this icon shows whether manual card configuration of this DCP-1721 is on [LOC] or off [REM]
- (b) this icon reports the status of the AES data stream being monitored by this probe. Move the cursor over the icon to see a more detailed description in the message area.
- (c) this icon shows the status of the alarms associated with this probe

Move the cursor over an icon to see its current status in the **message area** below the icons. If there is an error status, the message will appear automatically, as shown in the example. If there are multiple error messages, the display will cycle through them.

Meter

The Meter is Miranda's module for displaying a real-time audio meter representation of the audio data stream from the source that the probe is monitoring. The Meter panel in the DCP-1721 control panel shows the meter itself, plus the status of all parameters measured by the probe.

Click on the arrow icon to open the Meter panel.

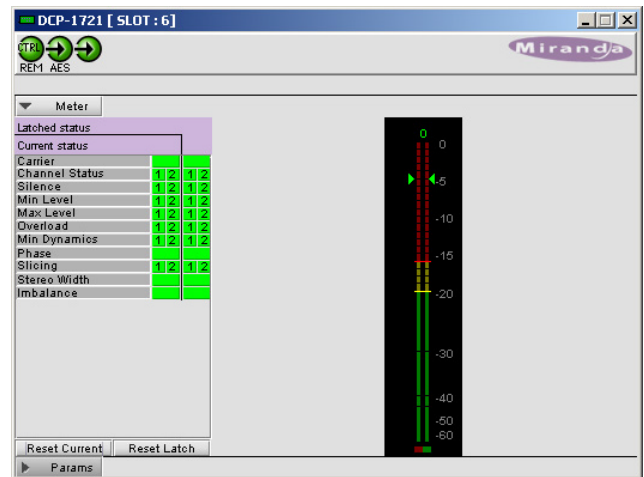

The display on the right side shows the audio level meter representation of the digital audio data stream that is being monitored by the DCP-1721.

DCP-1721 Digital Audio Control Probe Guide to Installation and Operation

Status Display: on the left side of the panel is a display of the current status of the parameters measured by the probe. Two separate status columns are shown:

- *Current status* shows the status now.
- *Latched status* shows the status as affected by latching.

When an error is detected, it is flagged in both columns. When the error disappears, the current status returns to OK. However, the latched status shows the error until it is manually cleared using the Reset Latch button beneath the status monitors. You can also reset the Current status, to confirm the presence of displayed errors.

Only those parameters that have been enabled are reported in the current status list; the others show a gray status box and their names are grayed in the list.

See the individual parameter descriptions in the *Params* section beginning below for information on enabling and configuring parameter tests.

Latched status		
Current status		
Carrier		
Channel Status	1 2	1 2
Silence	1 2	1 2
Min Level	1 2	1 2
Max Level	1 2	1 2
Overload	1 2	1 2
Min Dynamics	1 2	1 2
Phase		
Slicing	1 2	1 2
Stereo Width		
Imbalance		

Reset Current Reset Latch

Click on an individual parameter name to see the current settings for its measurement (*Overload* in this example). If the **Params** pane is open to the *Parameters* tab, it will switch to show the parameter you have selected in the status list, permitting rapid access to the parameter settings.

You can open both enabled and disabled tests using this method.

Latched status		
Current status		
Carrier		
Channel Status	1 2	1 2
Silence	1 2	1 2
Min Level	1 2	1 2
Max Level	1 2	1 2
Overload	1 2	1 2
CH1	Dur: 1 sec Enabled: ON Tresh: -6 dBu	Occ: 1 Wnd: 1mn
CH2	Dur: 1 sec Enabled: ON Tresh: -6 dBu	Occ: 1 Wnd: 1mn
Channels:	Not Locked	
Min Dynamics		
Phase		
Slicing	1 2	1 2
Stereo Width		
Imbalance		

Reset Current Reset Latch

Params

The Params pane has two sections:

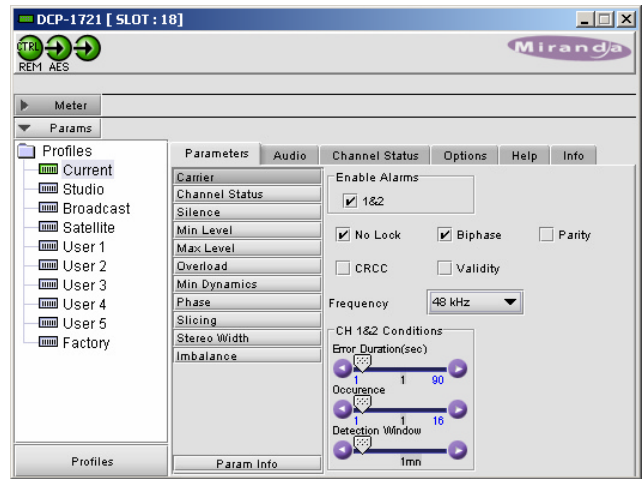

On the left, there is a tree chart of the ten Profiles available on the probe. A **Profile** is a set of values for all adjustable parameters and settings for the probe.

You always work with the current profile. As explained below, you can access and change all of the parameters and settings in the current profile.

The Studio, Broadcast, and Satellite Profiles are read-only data sets, representing measurement parameters appropriate to those applications.

The Factory profile is a read-only set of factory-selected values that can be used to return your probe to a standard operating condition.

The parameter values included in these four read-only data sets are shown in the table on page 13.

To load one of these profiles into the Current profile, right-click on the appropriate profile in the tree, then right or left click on the *Load in Current* text that appears.

The five User Profiles are read-write data registers that allow you to save the contents of the Current Profile for later recall.

- Once you have configured a set of parameters that you want to save and reuse, right-click on the Current folder in the tree chart. A dialog will appear permitting you to save the current profile into one of the five User profiles. *Note that you will overwrite the current contents of that User profile without additional warning.*
- To load a saved profile back into the Current profile, right-click on the User profile in the tree, then right or left click on the *Load in Current* text that appears.

On the right, a pane with 6 tabs allows you to select a number of options:

- Parameters - set conditions for detecting and flagging errors (see this page)
- Audio - configure the probe's audio configuration and metering (see page 11)
- Channel Status – show the current measured status of the probe's input signal (see page 11)
- Options – (see page 12)
- Help – display information about a selected parameter (see page 12)
- Info - enter and retrieve information about this DCP-1721 (see page 12)

In many cases, controls are provided to configure the probe's features. Types of controls that may be found are:

Slider:



The current value is displayed beneath the center of the slider bar (e.g. 39 in the example shown). To change the value, move the slider by clicking and dragging it, or by clicking the arrow icon at either end.

Slider with data box:



The current value is displayed in the data box at the right hand side (e.g. 50 in the example shown). To change the value, move the slider by clicking and dragging it, or by clicking the arrow or double-arrow icon at either end, or type a new value directly into the data box, and hit "enter" from your keyboard. If you enter a value outside the permitted range (as shown beneath the slider), the data box will flash red and the value will not be changed.

Pull-down list:

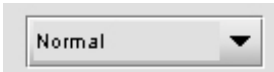

The current selection is shown on the icon. To change it, click on the down arrow at the right of the box, and click on the desired option in the list that appears below the box.

Check box (with label):

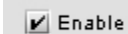

A selected box has a checkmark in it, as shown in the example, while an unselected box is blank. Click on the box to change its status.

Parameters tab

The **Parameters** tab lists all parameters detected and/or measured by the DCP-1721. The top parameter in the list is selected when you open the view, indicated by the darker color of its name box. To select any other parameter, click on it.

To the right of the parameter list appear all the controls necessary to configure the selected parameter.

The parameter configuration pane usually includes, from top to bottom:

- **Enable:** a checkbox to enable the alarm associated with this parameter
- **Threshold:** a threshold value for detection of an error. The error will be detected when the measured parameter falls above (or below, depending on the nature of the parameter) the indicated threshold value. In most cases this is a slider with data entry box.

(Carrier and Channel Status do not include a threshold adjustment)

- **Conditions:** indicates the conditions under which a detected error is flagged and reported.
 - ◊ **ERROR DURATION** – the length of time during which a parameter allowed to be out-of-tolerance without being identified as an error. This is useful for situations such as a hard switch or patch of an audio signal that does not need to be flagged as an error. If a parameter is continuously out of tolerance for the specified duration, then an error is considered to have been detected. However, this error will not be flagged (causing the status LED to change color and an error message to be sent out on the frame's interface) until the **OCCURRENCE / DETECTION WINDOW** conditions have been satisfied.
(Range: 0 to 90 seconds)
 - ◊ **OCCURRENCE:** the number of times that a detected error is allowed to occur in a specified **DETECTION WINDOW** before an error flag is set, and the error is reported (status LED changes color, and message sent on the interface)
(Range: 1 to 16)
 - ◊ **DETECTION WINDOW:** the time duration during which errors are counted to determine if the error flag should be set. This is a moving window, e.g. the previous 2 minutes, and only errors falling within that window are counted.
(Range: 1 min to 24 hours)

The following table shows the configuration panel for all of the parameters measured by the DCP-1721.

Carrier

Detect the presence of an input signal, and if present, examine its characteristics and internal data check bits.

Enable Alarms: check to enable this test

No Lock: activate if the probe input is not locked to a valid signal

Biphase: detect data stream errors by examining the biphase coding scheme.

Parity: detect data stream errors by examining the parity bit

CRCC: examine the CRCC byte to verify correct reception of the entire channel status data block

Validity: Examine the channel status validity flag bit

Frequency: set the frequency of the expected input signal

Conditions: set the Error Duration, Occurrence and Detection Window using the sliders (see definitions on page 5).

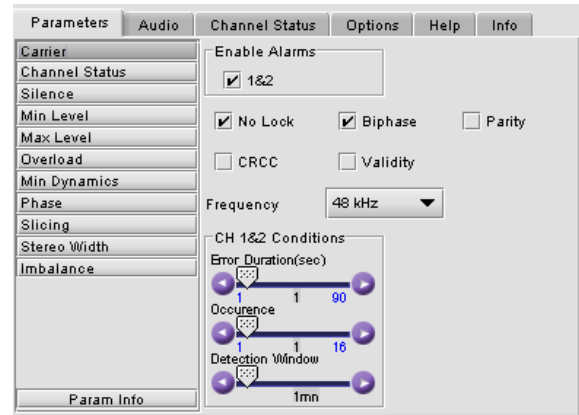

Channel Status

Detect if the measured channel profile does not match the profile set up using the tabs in this panel.

Enable Alarm: check to enable this test on the named channel.

Lock Channels: click to lock the sliders for the two channels together, allowing both to be adjusted simultaneously.

Channel Characteristics (tabs): the seven tabs provide access to various attributes of the encoded data stream, allowing the specification of a data stream profile. The error will be flagged if the data stream does not conform to these selections.

Note that the actual measured profile is shown under the Channel Status tab, described on page 11.

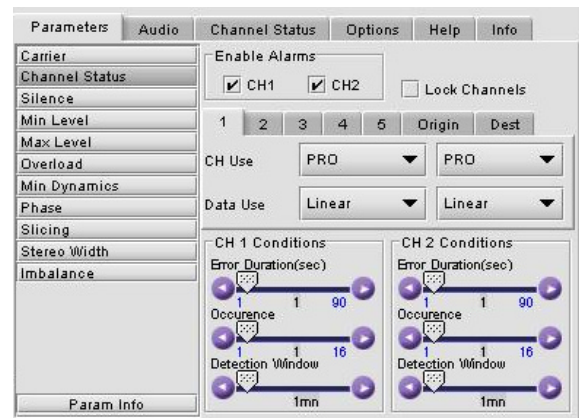

Tab 1:

CH Use: select the channels use from the pull-down list.
 Options: PRO (professional) only.

Data Use: select the use of the audio sample word from the pull-down list:
 Options: OFF, LINEAR, NON-LINEAR



Tab 2:

Freq Mode: Locking of source sample frequency:
 Options: OFF, N/I, UNLOCK

Sampl Freq: select the data sampling frequency
 Options: OFF, N/I, 96 kHz, 88.2 kHz, 48 kHz, 44.1 kHz, 32 kHz



Tab 3:

Emphasis: select the audio signal emphasis standard.
 Options: OFF, N/I, None, 50/15, J.17

CH Mode: select the encoded channel mode.
 Options: OFF, N/I, Stereo, 2 Ch, Single

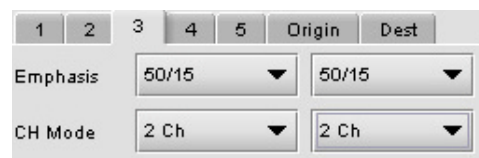

Tab 4:

User Bits: select the user bit format
Options: OFF, N/I, 192 bits, AES18

Aux Bits: select the auxiliary sample bits format
Options: OFF, 20 Not Def, 24 Main Aud, 20 Single

Tab 5:

Word Len: select the audio sample word length
Options: OFF, N/I, 24 bits, 20 bits, 18 bits, 16 bits

Digital audio Reference signal:
Options: OFF, Not Ref, Grade 1, Grade 2

Origin tab:

Alphanumeric channel origin data. For CH1 and CH2, click the check box if you want to include this parameter in the Channel Status error.

Enter a text string in the data box. Note that an alarm will be activated if this string and the *Origin* data in the incoming data stream do not exactly match.

Dest Tab:

Alphanumeric channel destination data. For CH1 and CH2, click the check box if you want to include this parameter in the Channel Status error.

Enter a text string in the data box. Note that an alarm will be activated if this string and the *Destination* data in the incoming data stream do not exactly match.

Conditions: set the Error Duration, Occurrence and Detection Window using the sliders (see definitions on page 5).

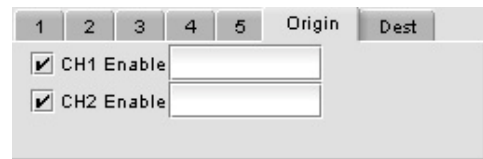
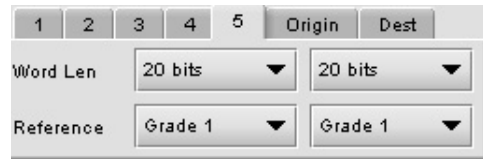
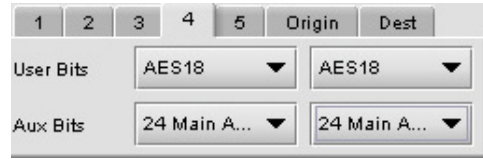

Silence

Verifies that the minimum level of the signal does not remain under a fixed threshold for longer than a specified duration. The integration time is 10 ms

This alarm is generally used to detect a signal absence. In that case, the threshold is set a few decibels below the expected minimum level and duration is set according to the sort of program, a few seconds for radio, a few tens of seconds for TV

Enable Alarm: check to enable this test on the indicated channels

Lock Channels: click to lock the sliders for the two channels together, allowing both to be adjusted simultaneously.

Threshold: set the level below which this condition will be flagged (between -40 and -80 dBFS)

Conditions: set the Error Duration, Occurrence and Detection Window using the sliders (see definitions on page 5).

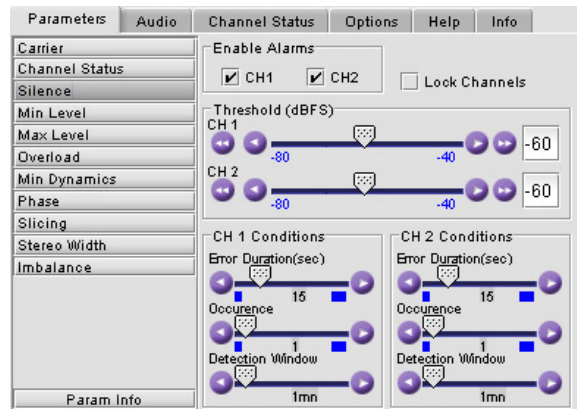

Min Level

Verifies that the minimum average level of the signal does not remain under a fixed threshold for longer than a specified duration. The integration time is 300 ms.

This alarm is generally used to detect too low an average level. In that case, the threshold is set a few decibels under the nominal level and the duration is set to a medium time.

Enable Alarm: check to enable this test on the named channel.

Lock Channels: click to lock the sliders for the two channels together, allowing both to be adjusted simultaneously.

Threshold: set the level below which this condition will be flagged (between -20 and -40 dBFS)

Conditions: set the Error Duration, Occurrence and Detection Window using the sliders (see definitions on page 5).

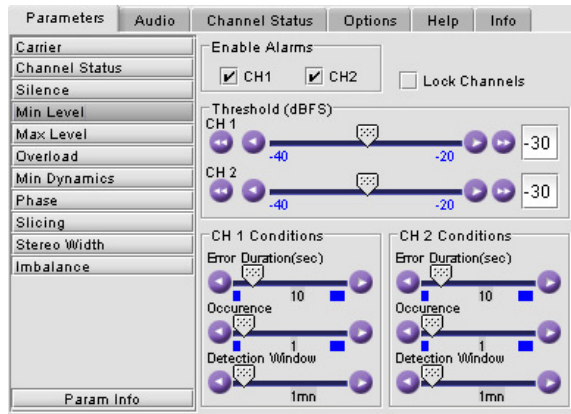

Max Level

Verifies that the maximum average level of the signal does not remain above a fixed threshold for longer than a specified duration. The integration time is 300 ms.

This alarm is generally used to detect too high an average level. In that case, the threshold is set a few decibels above the nominal level and the duration is set to a medium time

Enable Alarm: check to enable this test on the named channel.

Lock Channels: click to lock the sliders for the two channels together, allowing both to be adjusted simultaneously.

Threshold: set the level above which this condition will be flagged (between 0 and 20 dBFS)

Conditions: set the Error Duration, Occurrence and Detection Window using the sliders (see definitions on page 5).

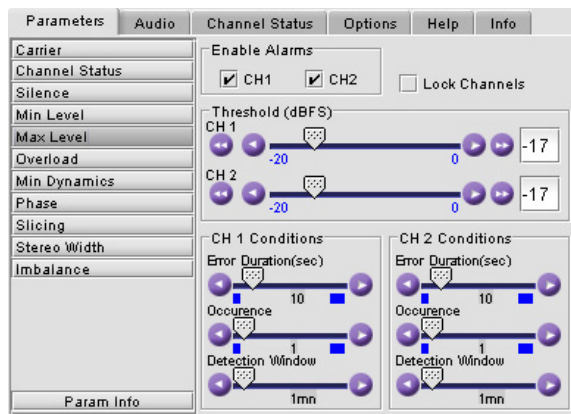

Overload

This analysis verifies that the maximum peak level of the signal does not remain above a fixed threshold for longer than a specified duration. The integration time is 10 ms and the peak value is latched for 1 s.

This alarm is generally used to avoid signal clipping. In that case, the threshold is set to the maximum level of the signal path and the duration is set to the minimum.

Enable Alarm: check to enable this test on the named channel.

Lock Channels: click to lock the sliders for the two channels together, allowing both to be adjusted simultaneously.

Threshold: set the level above which this condition will be flagged (between 0 and -12 dBFS)

Conditions: set the Error Duration, Occurrence and Detection Window using the sliders (see definitions on page 5).

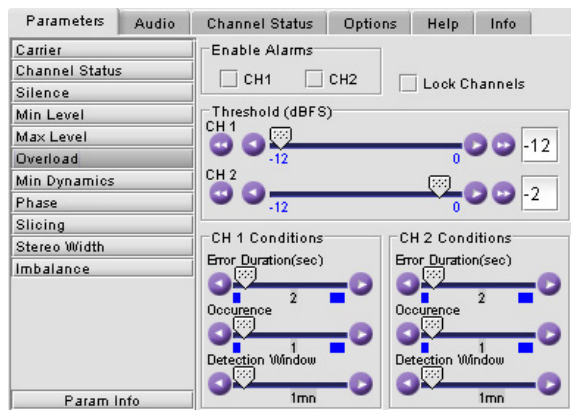

Min Dynamics

Verifies that the difference between the maximum and the minimum average levels is larger than a fixed threshold for longer than a specified duration. The integration time is 300 ms.

This alarm is generally used to detect a low value, or the absence, of dynamics that is often related to a broadcasting problem. Strong noise, a constant test signal or heavily-compressed modulation are all detected by this analysis. In that case, the threshold is set to a few decibels and the duration is set to a medium time (e.g. 8 dB, 30 s).

Enable Alarm: check to enable this test on the named channel.

Lock Channels: click to lock the sliders for the two channels together, allowing both to be adjusted simultaneously.

Threshold: set the level below which this condition will be flagged (from 1 to 20 dB)

Conditions: set the Error Duration, Occurrence and Detection Window using the sliders (see definitions on page 5).

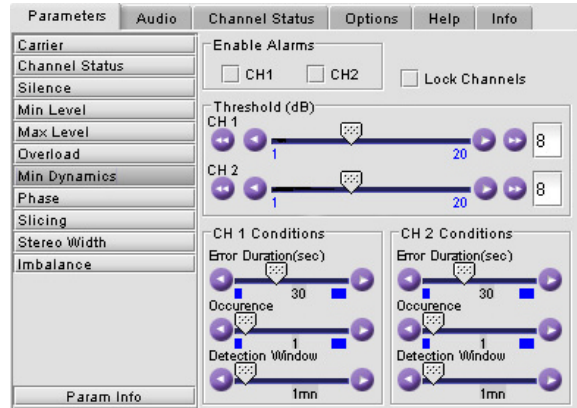

Phase

Verifies that the phase difference between the two channels remains under a fixed threshold for longer than a specified duration. The integration time is 600 ms.

This alarm is generally used to detect a phase error often related to incorrect wiring or to a recording problem.

The threshold is adjustable in 11.25° steps.

- -0.4 corresponds to a phase difference above 101.25°
- -1 corresponds to a phase difference above 168.75°

The threshold is set according to the sort of program and the duration is set to a medium time (e.g.: -0.6, 10 s).

Enable Alarm: check to enable this test.

Param Info: click to open the *Help* tab with this parameter selected, giving a description of the measurement.

Threshold: set the level above which this condition will be flagged (between -0.4 and -1)

Conditions: set the Error Duration, Occurrence and Detection Window using the sliders (see definitions on page 5).

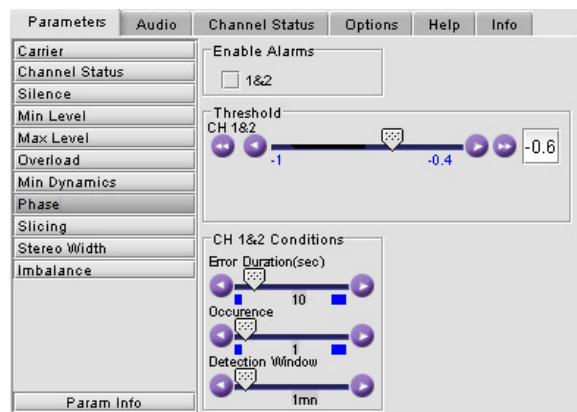

Slicing

Verifies that the number of important changes of level remains under a fixed threshold for longer than a specified duration. The integration time is 1 ms.

This alarm is generally used to detect brief cuts generated by a defective relay or wiring, characterized by instantaneous falls greater than 50 dB followed by period of silence at least 30 samples long ($\pm 600 \mu\text{s}$). The threshold corresponds to the number of cuts in a given time. (e.g. 4 cuts in 5 s).

Enable Alarm: check to enable this test on the named channel.

Lock Channels: click to lock the sliders for the two channels together, allowing both to be adjusted simultaneously.

Threshold: set the number of cuts above which this condition will be flagged (between 1 and 10).

Conditions: set the Error Duration, Occurrence and Detection Window using the sliders (see definitions on page 5).

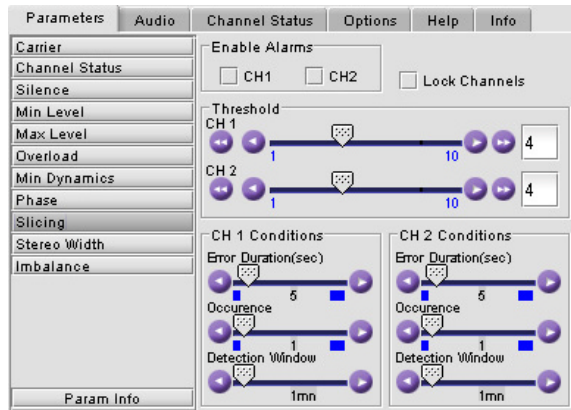

Stereo Width

Verifies that the stereo width remains larger than a fixed thresh-old for longer than a specified duration. Integration time is 10 ms.

This alarm is used to detect a monophonic broadcast when the signal is supposed to be stereo. Noise can add a small amount of width to the signal, so adjust the threshold appropriately - with a low-noise signal use low values (e.g. 2, 15 s), and with a noisy signal use high values (e.g. 8, 15 s).

Enable Alarm: check to enable this test.

Param Info: click to open the *Help* tab with this parameter selected, giving a description of the measurement.

Threshold: set the value above which this condition will be flagged, between 0 (mono) and 10 (stereo)

Conditions: set the Error Duration, Occurrence and Detection Window using the sliders (see definitions on page 5).

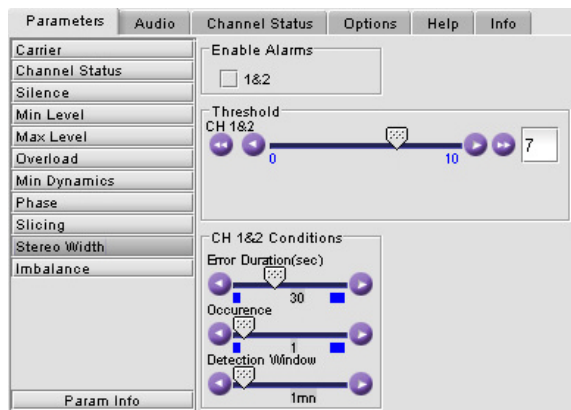

Imbalance

Verifies that the difference of level between the two channels remains under a fixed threshold for longer than a specified duration. The integration time is 300 ms.

This alarm is generally used when the source is stereo, to detect an imbalance between the two channels. This problem is often related to defective wiring or an incorrect level adjustment. In that case, the threshold is set to a few dB and the duration is set to a medium time (e.g. 5 dB, 10 s).

Enable Alarms: check to enable this test.

Param Info: click to open the *Help* tab with this parameter selected, giving a description of the measurement.

Threshold: set the level above which this condition will be flagged (between 0 and 10 dB)

Conditions: set the Error Duration, Occurrence and Detection Window using the sliders (see definitions on page 5).

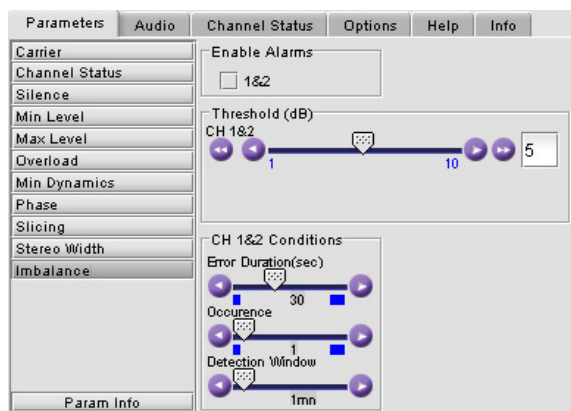

Audio tab

The **Audio** tab gives access resources to configure the audio connections to the probe.

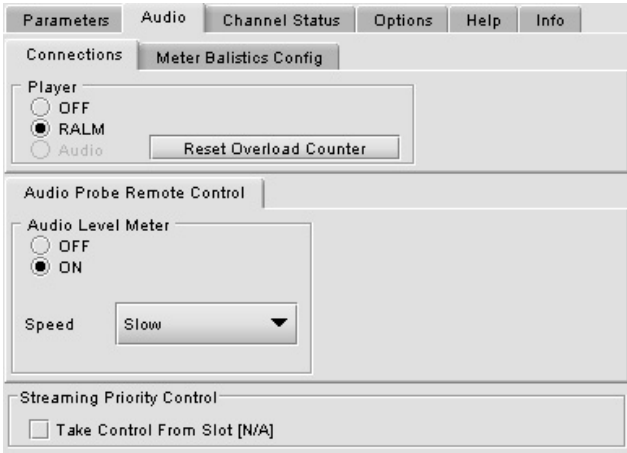

Connections tab – Player:

- OFF – No audio metering on this panel
- RALM – Remote Audio Level Meter – connects the audio meter on the Meter window of this control panel to the sampled audio level data received from the DCP-1721 card.
- Audio – (not supported in this version)

Reset Overload Counter – reset the overload counter to zero. See Overload Cursor in the Meter Ballistics section for more information.

Meter Ballistics Config tab

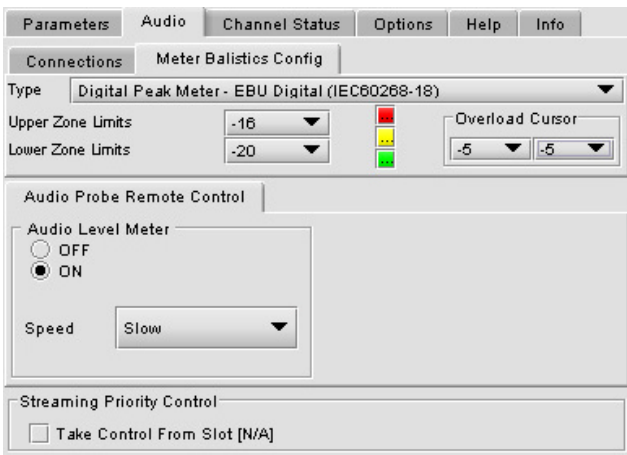

Type – select a type of meter from the pull-down list

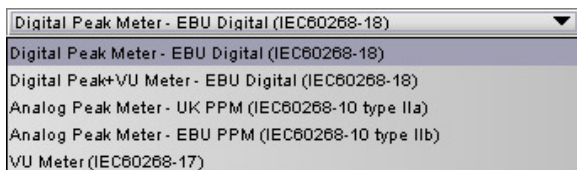

Upper Zone Limits – select the crossover level between the upper and middle zones of the meter (the range of values shown in the pull-down list depends on the meter type)

Lower Zone Limits – select the crossover level between the middle and lower zones of the meter (the range of values shown in the pull-down list depends on the meter type)

Color samples – the three samples show the current selected color for the upper, middle and lower zones of the meter.

- Click on the color sample of a zone to open a color selection panel to choose a different color for that zone

Overload Cursor – The overload cursor appears on the meter as an arrowhead in the meter scale. The two pull-down boxes set the position of the overload cursor on the left and right meters. If the audio level on that channel goes above the cursor, the Overload Counter at the top of the meter is incremented.

Audio Probe Remote Control tab

Audio Level Meter – turn the meter off or on

Speed – select the meter response from the pull-down list, either fast, medium or slow.

Streaming Priority Control

Click the **Take control from Slot [###]** checkbox to force the Densité Controller for this frame to assign more bandwidth for this card's streaming output. Only one card in the frame can use this feature. It has no effect unless you have selected **Fast** for the refresh rate. The actual slot number of this card, as shown in the window title bar, will appear when the checkbox is ticked.

Channel Status tab

The **Channel Status** tab shows the current status of all audio signal parameters measured by the DCP-1721 on the input AES data stream. The parameter values which the probe compares to these in order to detect errors are set in the various tabs on the Channel Status item in the Parameters tab. There is no data entry on this tab.

Parameter Name	Channel 1	Channel 2
Format Use	CONS	CONS
Data Type	Linear	Linear
Emphasis	None	N/I
Locking of Source	Unlock	N/I
Sampling Frequency	96 kHz	88.2 kHz
Channel Mode	Single/Double Sampl. F...	N/I
User Bits Use	N/I	192 bits
Aux Bits Use	20 Not Def	20 Not Def
Word Length	16 Bits	19 Bits
Reference Signal	Not Ref	Not Ref
Origin		
Destination		

Options tab

In this release, the **Options** tab shows only the serial number of the probe.

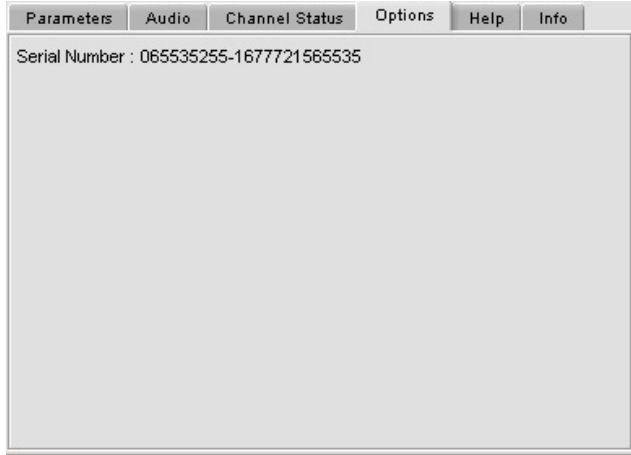

Help tab

The **Help** tab shows information concerning the currently-selected parameter. A text definition and in some cases a diagram explain the measurement made by the DCP-1721.

As an example, here is the *Help* display when *Silence* is selected from the pull-down list:

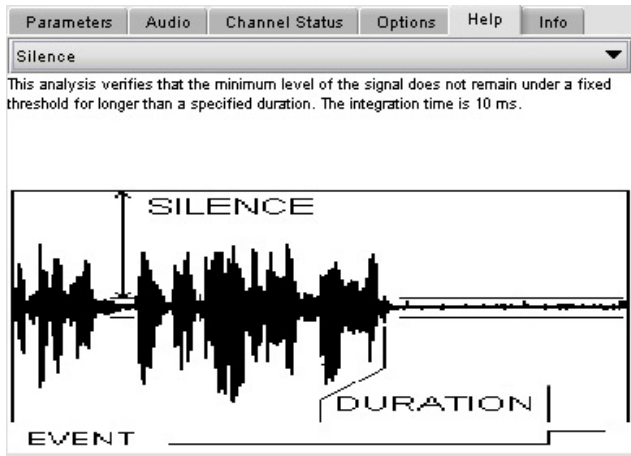

See the explanations of the individual parameters on pages 6 to 10 for additional information about the definition and suggested setup values.

Info tab

The **Info** tab provides information about the DCP-1721, and provides some data entry options.

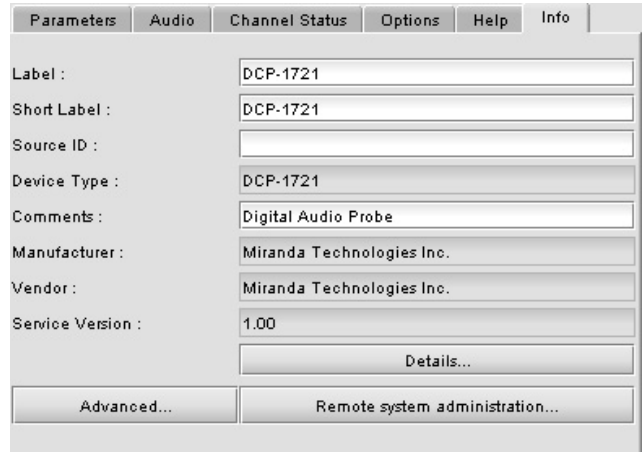

Label: Type a name for this device into the data entry box

Short Label: Enter an alternative short-form label

Source ID: Enter the name of the source this probe is monitoring

Comments: Type any desired text into this box

Details...: click on this button to get information about the manufacturing process and panel version.

Advanced...: Click on this button to get the Miranda Long ID of this DCP-1721. The Miranda Long ID is the address of this probe in the iControl network, and is required by some devices, e.g. Kaleido, to access this probe.

Remote System Administration...:

Click on this button to open the *Joining Locators*: DCP-1721 data entry box.

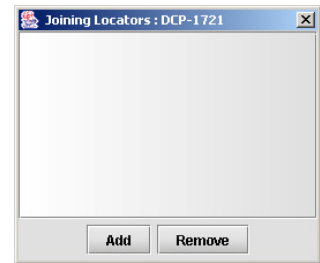

CONFIGURING ERROR STATUS REPORTING

The user can configure the response of the DCP-1721 to errors detected on any of its measured parameters. In iControl Navigator, right-click on the DCP-1721 icon, and select *Error/Warning Configuration* from the popup menu.

The Log Config panel opens, showing all measured parameters, and offering the following options for each:

- Select the checkbox between the Name and the Condition Level pull-down to enable reporting of that condition.
- Select the LEVEL that will be associated with a condition from the pull-down:
 - YELLOW = Warning
 - RED = Error
- Click the *Report GUI* checkbox to allow the status of this condition to be reflected in the DCP-1721's icon in iControl screens.

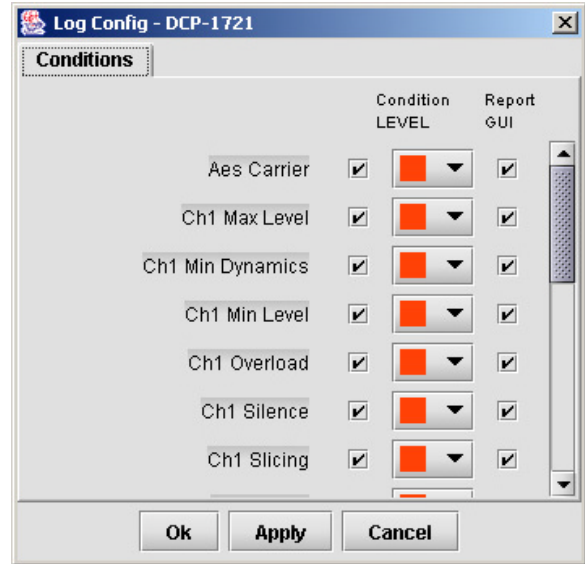

PARAMETER VALUES IN THE READ-ONLY PROFILES

DEFAULT VALUES	FACTORY		STUDIO		SATELLITE		BROADCAST	
	Threshold	Duration	Threshold	Duration	Threshold	Duration	Threshold	Duration
OVERLOAD	-2 dBFS	2 s	-2 dBFS	2 s	-1 dBFS	2 s	-2 dBFS	1 s
MAX. LEVEL	-17 dBFS	10 s	-15 dBFS	10 s	-8 dBFS	10 s	-10 dBFS	5 s
MIN. LEVEL	-30 dBFS	10 s	-28 dBFS	10 s	-19 dBFS	10 s	-22 dBFS	10 s
SILENCE	-60 dBFS	15 s	-58 dBFS	15 s	-49 dBFS	15 s	-52 dBFS	15 s
MIN. DYNAMICS	8 dB	30 s	8 dB	30 s	8 dB	30 s	6 dB	30 s
SLICING	4	5 s	4	5 s	4	5 s	4	5 s
PHASE	-0,6	10 s	-0,6	10 s	-0,6	10 s	-0,6	10 s
STEREO WIDTH	7	30 s	7	30 s	7	30 s	7	30 s
IMBALANCE	5	30 s	5	30 s	5	30 s	5	30 s

DCP-1721 OPERATION USING THE LOCAL CONTROL PANEL

In addition to the iControl interface, which permits the DCP-1721 to be configured and operated remotely from any site with IP access, the DCP-1721 can be configured from the local control panel in its Densité frame.

Press the Select button on the front of the DCP-1721 card to assign the local control panel to the card. The card's STATUS LED will flash yellow.

Use the four keys on the local control panel to step through the menu to the desired parameter and set its value.

- [+] [-] Used for up and down menu navigation and value modification
- [SELECT] Gives access to the next menu level. When a parameter value is shown, pushing this button once enables modification of the value using

the [+] and [-] buttons; a second push confirms the new value

[ESC] Cancels the effect of unconfirmed parameter value changes; pushing [ESC] causes the parameter to revert to its former value.

Pushing [ESC] moves the user back up to the previous menu level. At the main menu, [ESC] does *not* exit the menu system. To exit, re-push the [SELECT] button on the DCP-1721

If no controls are operated for 30 seconds, the controller reverts to its normal standby status, and the selected card's STATUS LED reverts to its normal operating mode

The menu structure is shown on pages 14-16, and is described in detail beginning on page 16.

DCP-1721 Digital Audio Control Probe Guide to Installation and Operation

DCP-1721 MENU STRUCTURE

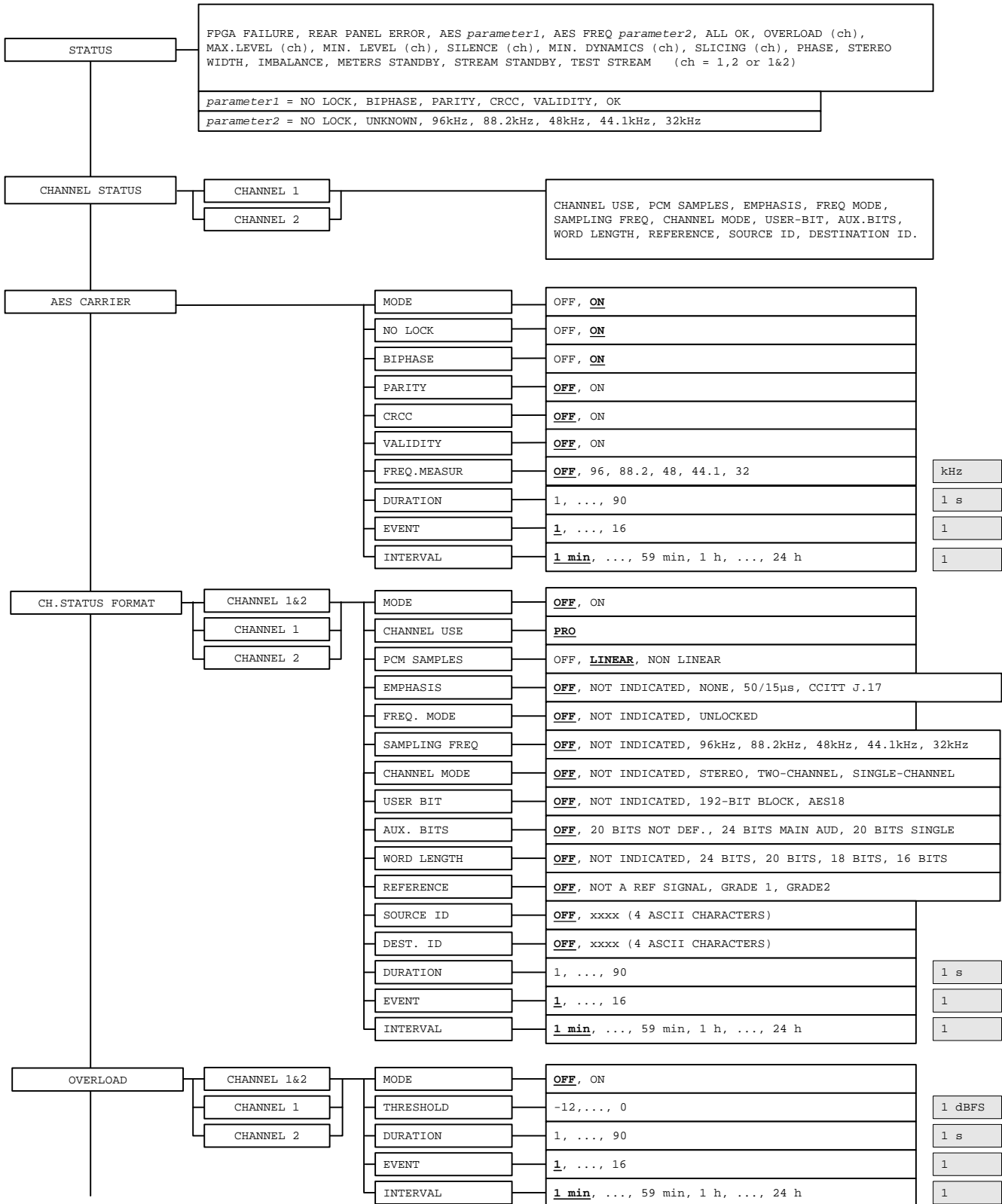

DCP-1721 MENU STRUCTURE (Continued)

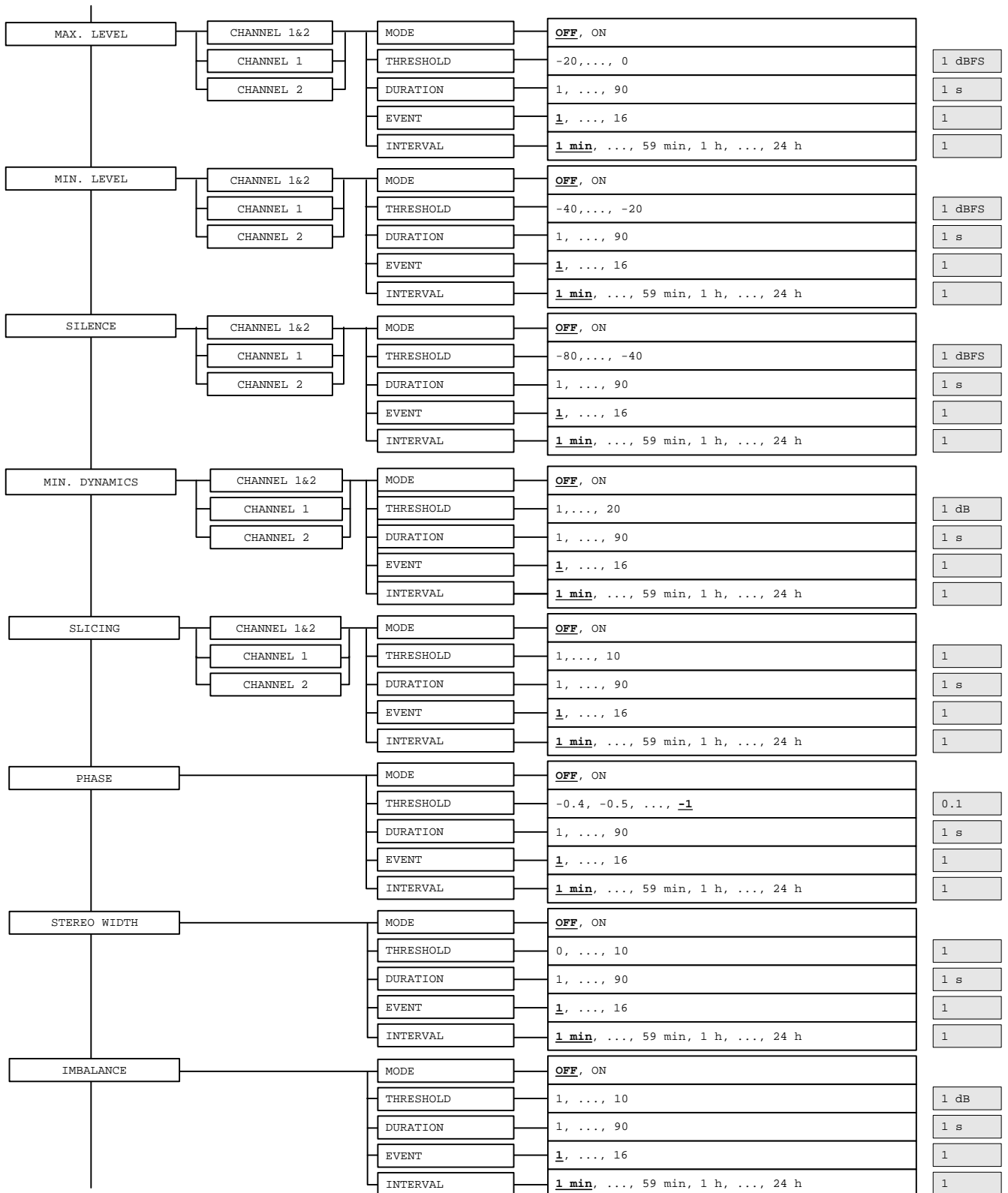

DCP-1721 MENU STRUCTURE (Continued)

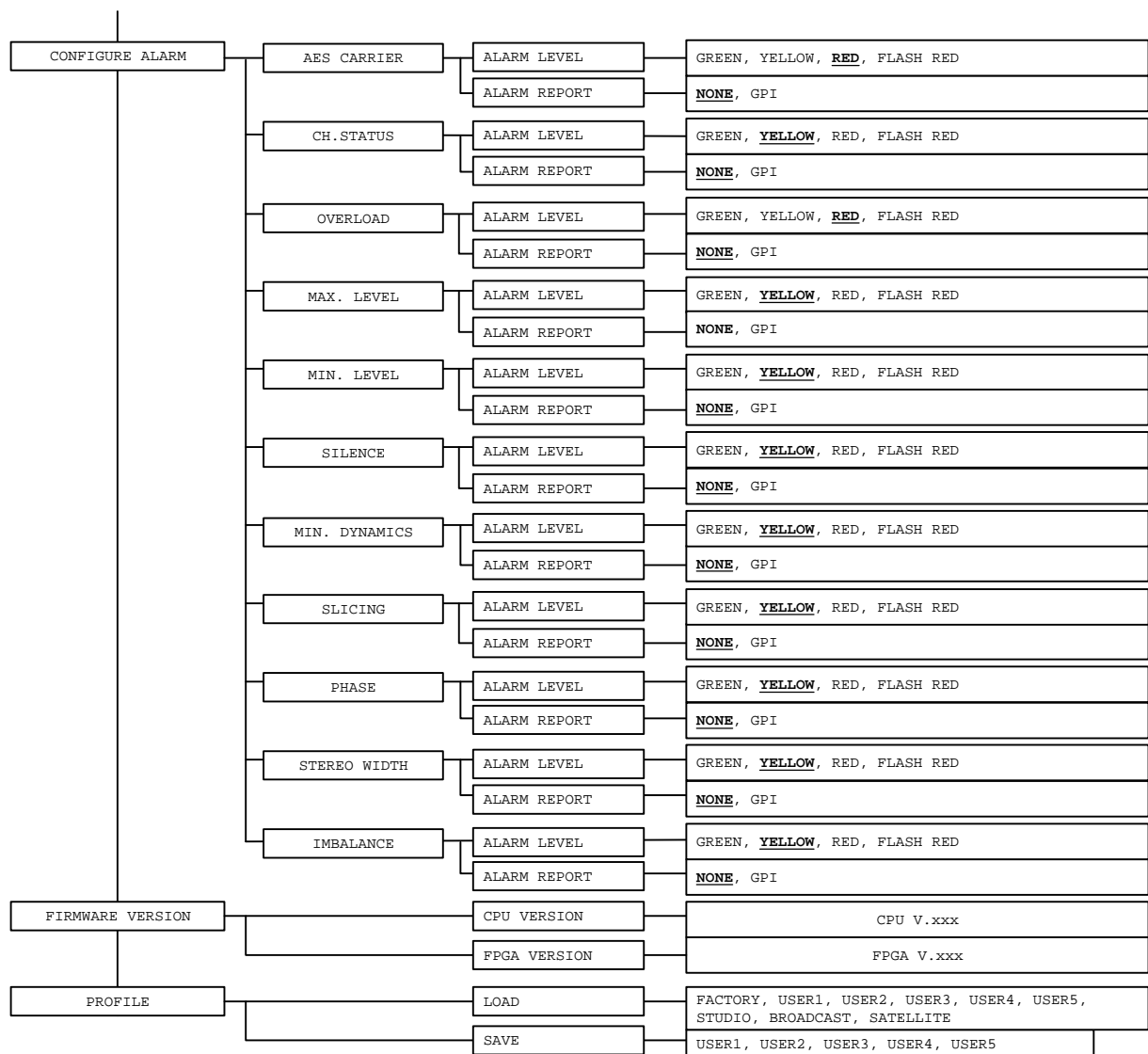

DESCRIPTION OF MENU CONTENTS

STATUS menu

Displays the status of the different board alarms, even if not configured to activate the *STATUS* Led.

ALL OK indicates an absence of alarms.

- In the list below, (ch.) =1, 2, or 1&2

FPGA FAILURE Faulty programmable component.

REAR PANEL ERROR Indicates an absence of the rear panel or an incompatibility between the module and the rear

panel. The *STATUS* led turns on flashing red.

AES (parameter) AES carrier, only the highest rank error is displayed. It can be NO LOCK, BIPHASE, PARITY, CRCC or VALIDITY. No error displays OK.

AES FREQ (param.) The input signal sampling frequency is measured and this parameter gives the value of the closest standard sampling frequency with a +/- 4% window.

ALL OK No alarms

OVERLOAD (ch.)	Indicates a peak level error.
MAX.LEVEL (ch.)	Indicates an average maximum level error.
MIN.LEVEL (ch.)	Indicates an average minimum level error.
SILENCE (ch.)	Indicates a signal absence error.
MIN.DYNAMICS (ch.)	Indicates a lack of dynamics.
SLICING (ch.)	Indicates sound with cuts.
PHASE ERROR	Indicates a phase error.
WIDTH ERROR	Indicates a stereo width error.
IMBALANCE	Indicates an average level difference between the two channels.
METERS STANDBY	The meter data is not transmitted
STREAM STANDBY	The audio data is not transmitted.
TEST (ch.)	The tone generator is activated.

CHANNEL STATUS menu

This menu gives access to the most relevant parameters coded with the channel status bit on a per channel basis. They will be exact only in professional mode.

CHANNEL USE	Displays PRO or CONSUMER.
PCM SAMPLES	Coding of incoming data: LINEAR or NON LINEAR.
EMPHASIS	Coding of the emphasis applied on the signal.
FREQ MODE	Indicates if the source is locked to a local reference signal.
SAMPLING FREQUENCY	Value of the sampling frequency.
CHANNEL MODE	Describes the way the two channels are used.
USER BIT	Utilization of the user bits.
AUX. BITS	Utilization of the auxiliary bits.
WORD LENGTH	Coded quantization value.
REFERENCE	Specifies if the source is a reference signal.
SOURCE ID	"origin" signal message (4 ASCII characters).
DESTINATION ID	"destination" signal message (4 ASCII characters).

Individual Parameter menus

These describe the configuration of the alarms for each individual parameter. Each menu contains some or all of the following:

CHANNEL (1, 2, 1&2)	Selection of channel 1, 2 or both.
MODE	Parameter alarm off/on.
THRESHOLD	Parameter-dependant adjustable threshold (see below).
DURATION	Range from 1 to 90 s. An event occurs each time the threshold is exceeded for the specified duration.
EVENT	To set the number of events, from 1 to 16, within the specific time interval. An error is generated when this limit is exceeded during the specified interval.
INTERVAL	Adjustable to cover short and long periods of time, from 1 to 59 min and then from 1 to 24 h.

AES CARRIER menu

Allows the selection of the AES carrier error used to generate an alarm: NO LOCK, BIPHASE, PARITY, CRCC and VALIDITY errors can be each ON or OFF. The **FREQ.MEASUR** error is generated if the measured sampling frequency is different of the selected standard value.

CH. STATUS FORMAT menu

Allows the selection of the channel status format error used to generate an alarm. For each parameter an error is generated if the measured parameter is different from the corresponding selected value. Refer to the menu for the different alternatives.

OVERLOAD menu

This analysis verifies that the maximum peak level of the signal does not remain above a fixed threshold for longer than a specified duration. The integration time is 10 ms and the peak value is latched for 1 s.

- This alarm is generally used to avoid signal clipping. In that case, the threshold is set to the maximum level of the signal path and the duration is set to the minimum.

THRESHOLD The maximum peak level can be adjusted between 0 and -12 dBFS.

MAX LEVEL menu

Verifies that the maximum average level of the signal does not remain above a fixed threshold for longer than a specified duration. The integration time is 300 ms.

- This alarm is generally used to detect too high an average level. In that case, the threshold is set a few decibels above the nominal level and the duration is set to a medium time

THRESHOLD The maximum level can be adjusted between 0 and 20 dBFS.

MIN LEVEL menu

Verifies that the minimum average level of the signal does not remain under a fixed threshold for longer than a specified duration. The integration time is 300 ms.

- This alarm is generally used to detect too low an average level. In that case, the threshold is set a few decibels under the nominal level and the duration is set to a medium time.

THRESHOLD The minimum level can be adjusted between -20 and -40 dBFS.

SILENCE menu

Verifies that the minimum level of the signal does not remain under a fixed threshold for longer than a specified duration. The integration time is 10 ms.

- This alarm is generally used to detect a signal absence. In that case, the threshold is set a few decibels below the expected minimum level and duration is set according to the sort of program, a few seconds for radio, a few tens of seconds for TV.

THRESHOLD The minimum level can be adjusted between -40 and -80 dBFS.

MIN DYNAMICS menu

Verifies that the difference between the maximum and minimum average levels is larger than a fixed threshold for longer than a specified duration. The integration time is 300 ms.

- This alarm is generally used to detect a low value, or the absence, of dynamics that is often related to a broadcasting problem. Strong noise, a constant test signal or heavily-compressed modulation are all detected by this analysis. In that case, the threshold is set to a few decibels and the duration is set to a medium time (e.g. 8 dB, 30 sec)

THRESHOLD Its value can be adjusted from 1 to 20 dB

SLICING menu

Verifies that the amount of important changes of level remains under a fixed threshold for longer than a specified duration. The integration time is 1 ms.

- This alarm is generally used to detect brief cuts generated by a defective relay or wiring, characterized by instantaneous falls greater than 50 dB followed by period of silence at least 30 samples long ($\pm 600 \mu\text{s}$). The threshold corresponds to the number of cuts in a given time. (e.g. 4 cuts in 5 s)

THRESHOLD Its value can be adjusted from 1 to 10.

PHASE menu

Verifies that the phase difference between the two channels remains under a fixed threshold for longer than a specified duration. The integration time is 600 ms.

- This alarm is generally used to detect a phase error often related to incorrect wiring or to a recording problem.
- The threshold is adjustable in 11.25° steps.
 - ◇ -0.4 corresponds to a phase difference above 101.25°
 - ◇ -1 corresponds to a phase difference above 168.75°
- The threshold is set according to the sort of program and the duration is set to a medium time (e.g.: -0.6, 10 s)

THRESHOLD Its value can be adjusted from -0.4 to -1.

STEREO WIDTH menu

Verifies that the stereo width remains larger than a fixed threshold for longer than a specified duration. The integration time is 10 ms.

- This alarm is used to detect a monophonic broadcast when the signal is supposed to be stereo. Noise can add a small amount of width to the signal, so adjust the threshold appropriately - with a low-noise signal use low values (e.g. 2, 15 s), and with a noisy signal use high values (e.g. 8, 15 s).

THRESHOLD Its value can be adjusted from 0 (mono) to 10 (stereo)

IMBALANCE menu

Verifies that the difference of level between the two channels remains under a fixed threshold for longer than a specified duration. The integration time is 300 ms.

- This alarm is generally used when the source is stereo, to detect an imbalance between the two channels. This problem is often related to defective wiring or an incorrect level adjustment. In that case, the threshold is set to a few dB and the duration is set to a medium time (e.g. 5 dB, 10 s).

THRESHOLD It can be adjusted from 0 to 10 dB.

CONFIGURE ALARM menu

Set the *STATUS* LED color and/or GPI relay activation for each detected error.

ALARM LEVEL Set the *STATUS* LED color (GREEN, YELLOW, RED or FLASH RED) for

each error. This selection does not affect the {STATUS} menu display.

ALARM REPORT Select **GPI** to activate a relay when an error is detected. The default value is **NONE** for all errors.

FIRMWARE VERSION menu

CPU VERSION Microcontroller firmware version.

FPGA VERSION Programmable logic element firmware version.

PROFILE menu

The **STUDIO**, **BROADCAST**, and **SATELLITE** Profiles are read-only data sets, representing measurement parameters appropriate to those applications

The **FACTORY** profile is a read-only set of factory-selected values that can be used to return your probe to a standard operating condition.

The parameter values included in these four read-only data sets are shown in the table on page 13.

The five **USER** Profiles (**USER1** to **USER5**) are read-write data registers that allow you to save the contents of the **CURRENT** Profile for later recall.

LOAD Recall the stored parameters from a selected **USER** profile into the **CURRENT** profile.

SAVE Store the **CURRENT** profile into a selected **USER** profile

COMPLIANCE

Radio Frequency Interference and Immunity

This unit generates, uses, and can radiate radio frequency energy. If the unit is not properly installed and used in accordance with this guide, it may cause interference with radio communications. Operation with non-certified peripheral devices is likely to result in interference with radio and television reception. This equipment has been tested and complies with the limits in accordance with the specifications in:

FCC Part 15, Subpart B; EN55022; EN50204; EN61000-3-2, -3; EN61000-4-2, -3, -4, -5, -6, -11

CONTACT MIRANDA

For technical assistance, please contact the Miranda Technical support centre nearest you:

Americas

Telephone:
+1-800-224-7882

e-mail:
techsupp@miranda.com

Asia

Telephone:
+81-3-5730-2987

e-mail:
asiatech@miranda.com

**Europe, Middle East,
Africa, UK**

Telephone:
+44 (0) 1491 820222

e-mail:
eurotech@miranda.com

France (only)

Telephone:
+33 (0) 1 55 86 87 88

e-mail:
francetech@miranda.com

Visit our web site at www.miranda.com