



Telecast
Fiber Systems, Inc.

Diamondback™
8 Channel Video Multiplexer

Instruction Manual

Telecast Fiber Systems, Inc.
102 Grove Street
Worcester, MA 01605
Tel: 508-754-4858
Fax: 508-752-1520
www.telecast-fiber.com

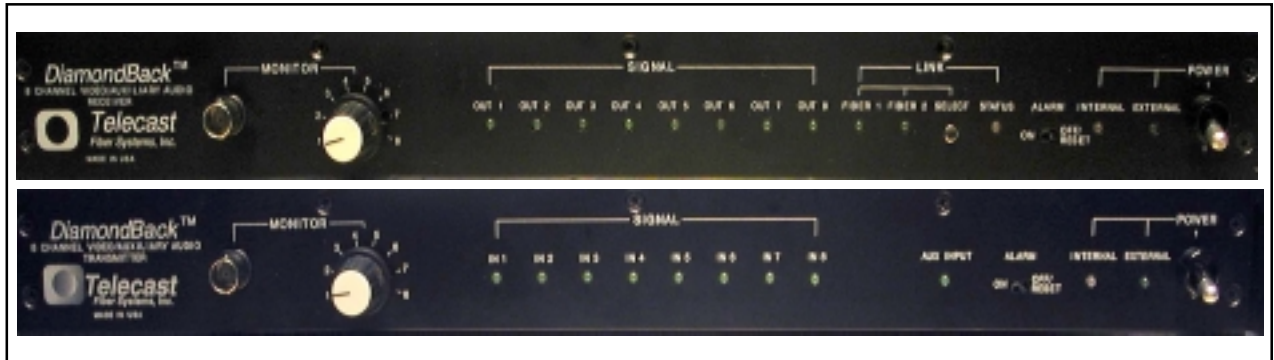

DiamondBack Receiver and Transmitter Front



DiamondBack Receiver and Transmitter Rear

Table of Contents

Laser Safety	iv
FCC Part A Manual Notice	iv
Warning CE	iv
Introduction	1
Setup	1
Packing List	1
Attaching the Rack Mount Adapters	2
Line Power	2
Configuring Signal I/O	3
Rear Panel Connections	3
Front Panel Indicators and Control	3
System Example	4
Fiber Optic Cable Runs	5
Making the Fiber Connection	6
Optical Transmitter Losses	6
Power Switch	7
System Block Diagrams	7
Battery Pack	9
Repair	9
Accessory List	9
Troubleshooting	10
Specifications	11
Warranty	12

List of Figures

Figure 1.	Installing the Rack Mount Adapters	2
Figure 2.	Diamondback Rear Panel	3
Figure 3.	Front Panels, RX (Upper) and TX (Lower)	3
Figure 4.	Example of the DiamondBack/Adder 161	5
Figure 5.	TX Block Diagram	8
Figure 6.	TX Input Schematic	8
Figure 7.	RX Block Diagram	9
Figure 8.	RX Output Schematic	9

List of Tables

Table 1.	Power Input Pin-outs	2
Table 2.	Optical Loss Margin	7
Table 3.	Troubleshooting Chart	11

Laser Safety

Warning!

Class 1 Laser. Do not stare into a connector port or fiber.

Laser Radiation

The unit is a CDRH Class 1 laser device. Although this means it is eye safe, you must avoid looking directly at, or staring into, the laser beam located on an ST connector or on the end of a fiber.

Infrared radiation is produced at the fiber connection port on the rear of the unit and at the end of unterminated optical fibers that are attached to this port. Avoid long, direct exposure to the light that comes from these sources.

Do not power up the unit when there is no fiber attached to the fiber connection port.

There are no user adjustments inside the Diamondback. Do not attempt any type of service to this instrument other than so instructed in this manual. Refer servicing to Telecast Fiber Systems, Inc.

FCC Part A Manual Notice

This equipment has been tested and found to comply with the limits for a Class A digital device, pursuant to part 15 of the FCC rules. These limits are designed to provide reasonable protection against harmful interference when the equipment is operated in a commercial environment. This equipment generates, uses and can radiate radio frequency (RF) energy and, if not installed and used in accordance with the instruction manual, may cause harmful interference to radio communications. Operation of this equipment in a residential area is likely to cause harmful interference in which case the user will be required to correct the interference at his own expense.

Warning CE

This is a Class A product. In a domestic environment this product may cause radio interference.

Introduction

The Telecast DiamondBack™ system consists of a single or dual optical output fiber optic transmitter/multiplexer (TX) and a mating receiver/demultiplexer (RX). The TX unit multiplexes and launches simultaneously on the fiber up to eight channels consisting of video inputs and/or data signals. The data signals can be the coaxial output of the Telecast Adder™ 161 or Adder™ 882i. In this way, the Diamondback can transmit a mix of video, audio and intercom on one singlemode fiber. Configuration diagrams are featured on page 5.

Within a DiamondBack TX, the video signals are first digitized at 147 MHz and then multiplexed at a data clock rate of 1.47 Gb/s. This digital data is converted to an optical signal and launched into the fiber. The DiamondBack RX receives the optical transmission and restores the video and data signals to the corresponding outputs.

The DiamondBack TX is optionally equipped with two parallel laser outputs for redundancy or split feeds. In redundant operation, the DiamondBack RX accepts two optical inputs, with automatic switchover protection.

DiamondBack electrical signal I/O channels are individually configured for video or data use by a toggle switch on the rear panel adjacent to the input BNC on the TX and its corresponding BNC output on the RX. The TX and RX units have similar appearances; front and rear views are shown in Figures 3 and 4. Front panel indicators for channel and system status are very similar, and the locations of the electrical I/O connections on the rear panels are identical.

A rotary switch and BNC output on both TX and RX front panels enables the selection of one of the eight video signal channels for display on a local monitor.

An internal Ni-Cad battery provides backup in the event of line power loss. DiamondBacks are housed in a standard 19 inch electronics rack.

Setup

Packing List

The DiamondBack system consists of:

- One DiamondBack TX Transmitter
- One DiamondBack RX Receiver
- Two external power supplies (AC/DC adapters)
- Rack mount adapter kits

After unpacking, inspect the units for mechanical damage, and all electrical connectors for bent or damaged pins and latches. Report any damage to the carrier and to Telecast Fiber Systems, Inc. Leave the protective caps on the optical connectors until it is time to attach the fiber. Replace the caps whenever the fiber is disconnected.

Attaching the Rack Mount Adapters

Units are shipped ready for bench use. To mount a unit in an electronics rack, the adapters must be attached. Each adapter is held in place by two #10 flat head screws; see Figure 1.

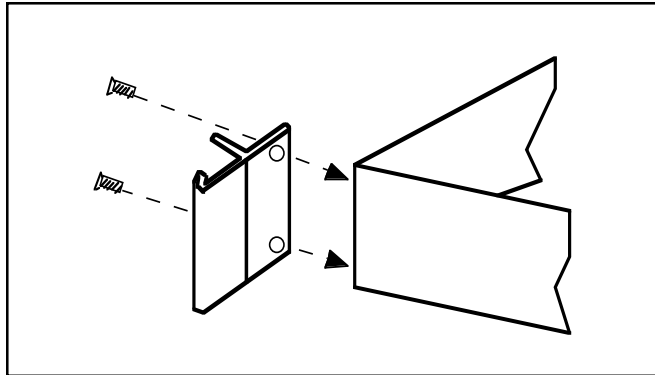

Figure 1. Installing the Rack Mount Adapters

Note: Place each unit in its intended location before attaching any cables or wires to prevent accidental damage to the cables or their connectors.

Line Power

Any power supply used with the DiamondBack must provide a minimum of 1.5 amps, continuous, at 12 to 24 VDC. Although the units will operate at 12 VDC, 13.8 VDC is required to charge the internal UPS battery. This battery charges whenever the input voltage is 13.8 VDC or higher. Full charge takes approximately 16 hours.

Power input is through a 4-pin XLR connector located on the left side of the rear panel; see Figure 2. Be sure that AC outlets are within reach of their 6-foot power cords. The Pin-out of the Power In connector is shown in Table 1.

Pin	Signal
1	ground
2	no connection
3	no connection
4	+12 to 24 VDC

Table 1. Power Input Pin-out

Configuring Signal I/O

Rear Panel Connections

All setups and connections are on the rear panel, which is the same for the TX and RX units; see Figure 2.

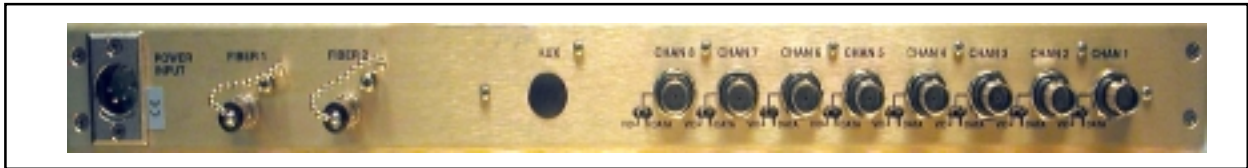

Figure 2. Rear Panels, same for TX and RX

The rear panel has 8 BNC female connectors. From left to right in Figure 2, they are:

Channel TX & RX. Chan 8 to Chan 1 are the video or data inputs on the TX and the corresponding channel outputs on the RX. Beneath each connector is a Vid/Data toggle switch which must be configured for either video (left) or data (right).

Caution: Toggle switches on the TX and RX must be in the same position, channel-for-channel and unused inputs and outputs should be switched into the **VIDEO** position.

Front Panel Indicators and Controls

The front panels of the RX and TX are shown in Figure 3.

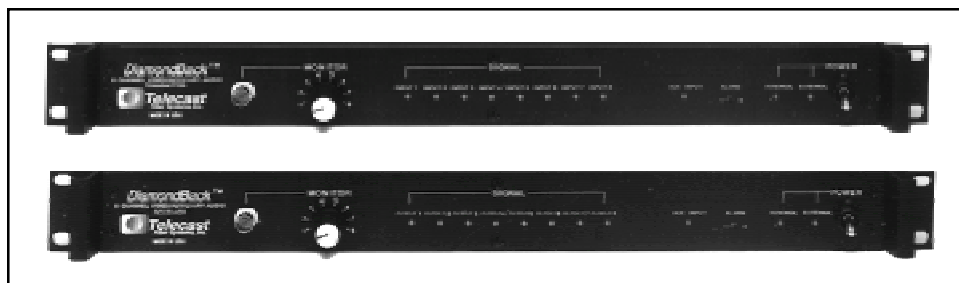

Figure 3. Front Panels, TX (Upper) and RX (Lower)

Monitor RX & TX. A rotary switch to select the video channel for output to the adjacent BNC. A standard composite video monitor can be connected to this port.

Signal	TX (signal input) and RX (signal output). LEDs, one per signal channel, which illuminate green when a video sync pulse or a data stream is present. These LEDs will flicker when unsynchronized video (e.g., RGB) is present.
Link	RX only. Includes the following: Fiber 1 & Fiber 2: LEDs which indicate the fiber being used to communicate with the transmitter. Select: A push-button that toggles between the two fiber inputs. The default on power up is always Fiber 1, if the TX is already activated. Status: LED which illuminates green if the system has valid optical data.
Power	External: LED which illuminates green when 12 to 24 VDC of external power is supplied to the unit. Internal: LED which illuminates green after approximately 30 minutes of battery charging, and illuminates red when external voltage is absent and the battery is discharging.
Alarm	TX Alarm: An intermittent beep will sound when the alarm switch is on and the system is being powered by the internal battery backup. The alarm will stop automatically if external power is restored. RX Alarm: For power monitoring conditions, the RX alarm functions the same as the TX alarm. For fiber switching situations, the alarm will continue to sound even if the optical signal is restored, indicating to the user the type of malfunction that has occurred. The RX alarm Off/Reset slide switch on the front panel must be manually reset.

System Examples

The combination of Telecast's DiamondBack video multiplexer and Telecast's Adder 161 Audio/Data multiplexer provides a powerful network solution for carrying audio, video and data economically from point to point. The Adder can be connected to any of the DiamondBack input channels switched to "Data" position on the rear panel.

An example of an efficient use of the DiamondBack and the Adder 161 is shown in Figure 4. The Adder 161 can multiplex up to 16 channels of audio, 2 streams of digital data, and 4 switch closures for delivery on its coaxial output to the DiamondBack TX.

Another example, not pictured, could have two sets of Diamondbacks transmitting and receiving in opposing directions. With this bi-directional transmission path (on one or two fibers) the Adder 882i can supply up to 10 2-way intercoms.

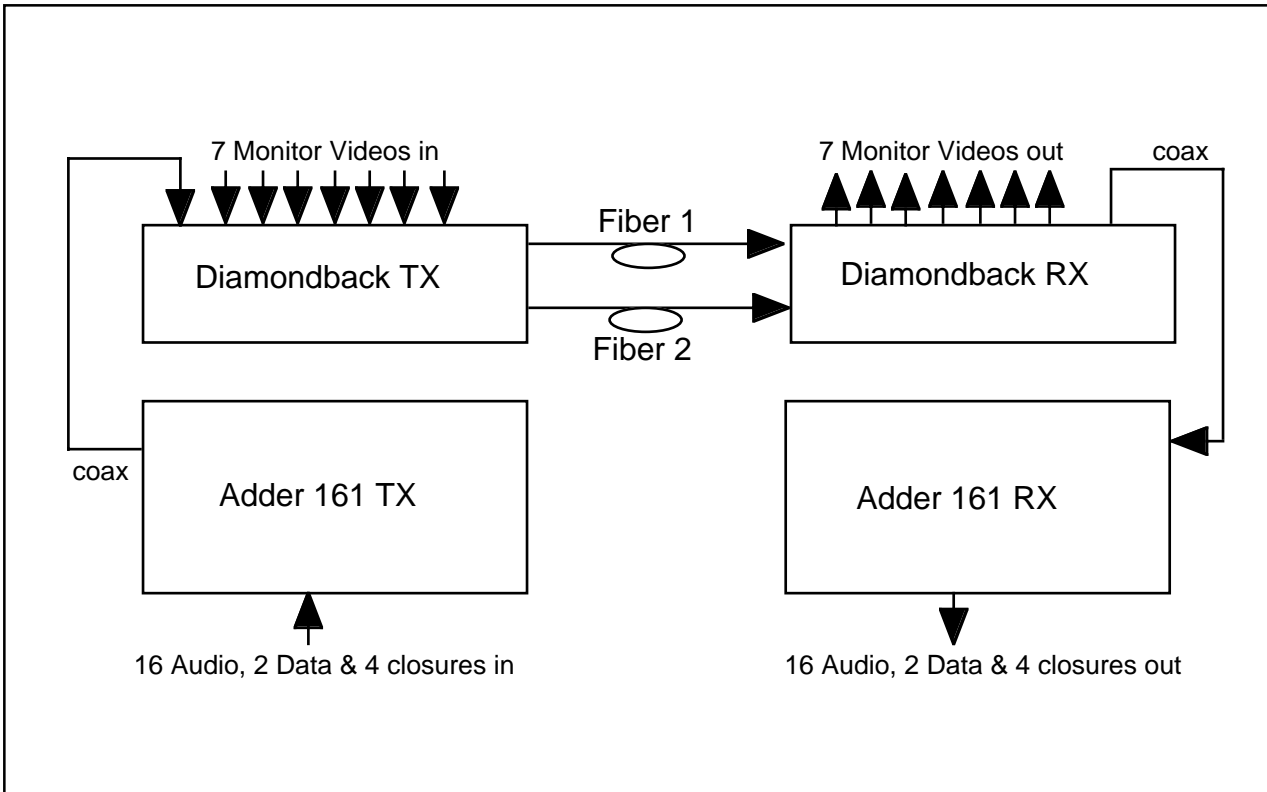

Figure 4. Example of the DiamondBack/Adder 161 Network

Fiber Optic Cable Runs

The optical output from the TX is generated by a laser diode that is coupled to the fiber. User connections are made at a bulkhead ST type connector on the rear panel. Operation is primarily intended for use on single mode fiber; consult the factory for multimode fiber operation.

The input at the RX uses a InGaAs pin diode and amplifier to convert the optical signal back into an electrical signal.

DiamondBack launches the signals into 9 micron diameter core single mode fibers. Assembled cables and connectors are available from Telecast Fiber Systems, Inc.

Warning:

Never look directly into the end of a connected optical fiber while any component is operating; eye damage is possible.

The Transmitter's optical outputs Fiber 1 and Fiber 2 have the following characteristics:

- Fully redundant
- Have independent power drivers
- Both remain active in the absence of a failure

The Receiver takes its signal selectively from Fiber 1. If the signal on Fiber 1 is lost, the RX automatically switches to its Fiber 2 input. If the signal on Fiber 1 is restored, and the signal on Fiber 2 is lost, the RX switches back to Fiber 1. If both fibers remain active, pressing the Select button on the front panel will toggle between them.

Making the Fiber Connection

1. Inspect the fiber ends and clean them with dry compressed air or with Kim-Wipes that have been wet with isopropyl alcohol. Fingerprints or other dirt on the optical connector end surfaces will reduce the received optical signal level.
2. Connect the fibers to their matching ports on both the TX and RX units.

Optical Transmitter Losses

The maximum fiber distance is defined by the optical loss operating margin. The RX signal must be - 21 dBm or higher. Losses on single mode fiber are approximately 0.5 dB/km or less. Refer to Table 1 for the expected TX output requirement and the consequent RX input power.

Signal	Min
TX Optical Output	- 6dBm
RX Optical Input	- 21dBm
Optical Loss Margin	15dBm

Table 2. Optical Loss Margin

Use an optical power meter for testing the optical signal development and its transmission over the fiber. Instructions for this test are supplied with the meter.

Power Switch

Never move the power switch on the front panel without first disengaging its lock by pulling on the switch lever. Be sure to switch power on to the transmitter and receiver; the power switches on both units must be on for the system to achieve normal function.

Never disconnect the DC power input connector without first turning the power switch lever off. Failure to do this will result in the discharge of the internal UPS backup battery, affecting its integrity and useable lifetime.

System Block Diagrams

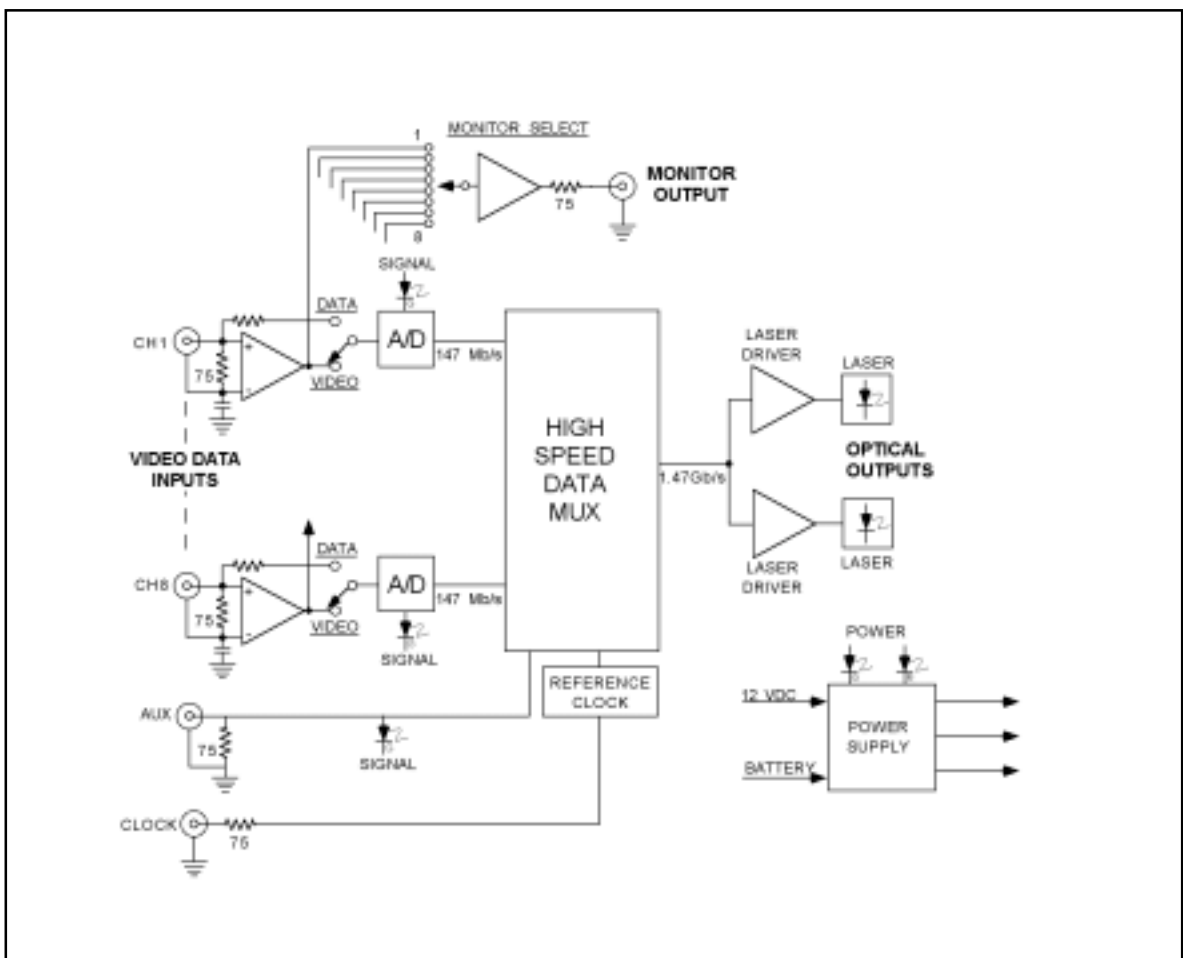

Figure 5. TX Block Diagram

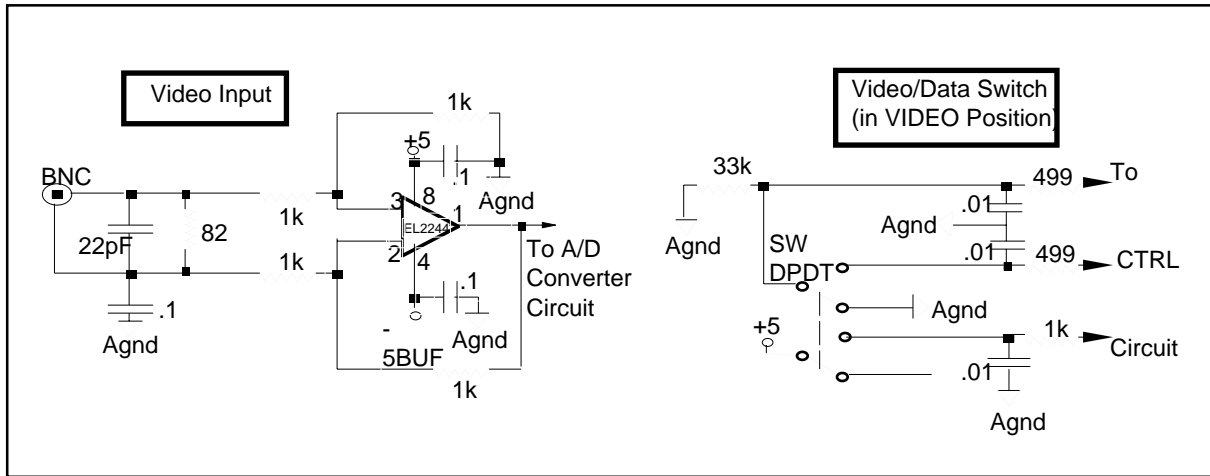

Figure 6. TX Input Schematic

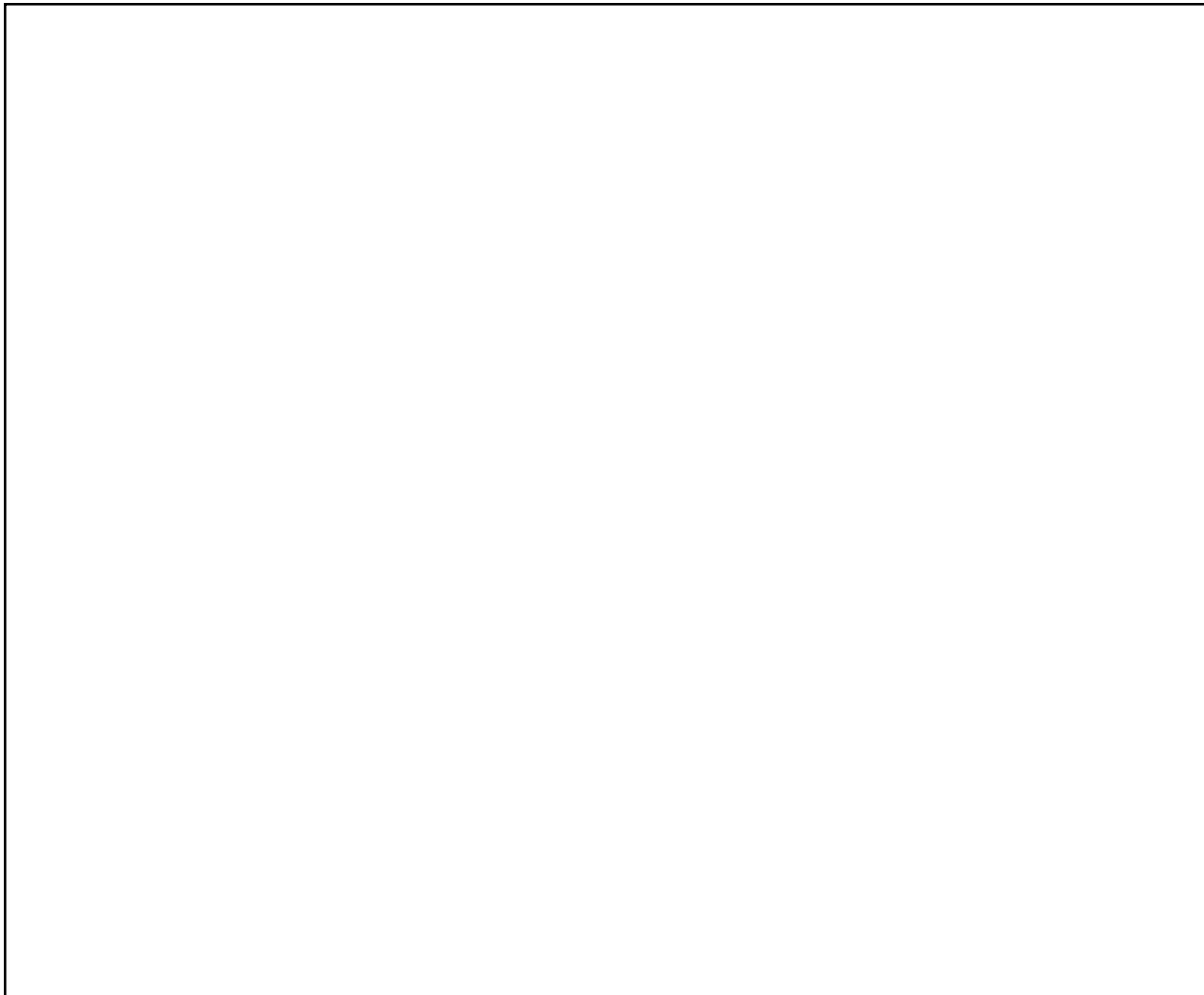

Figure 7. RX Block Diagram

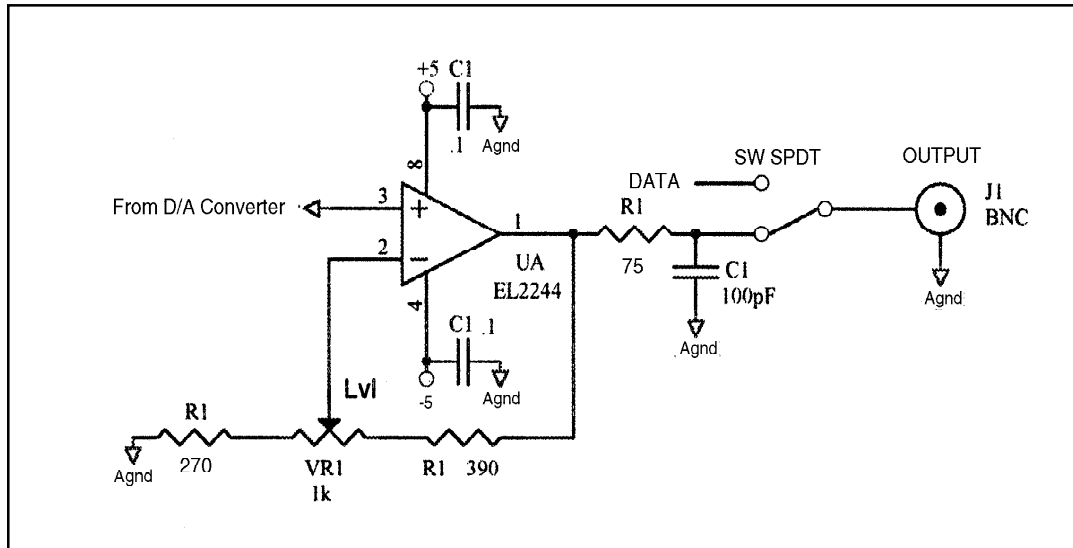

Figure 8. RX Output Schematic

Battery Pack

Replace the internal Ni-Cad battery pack every two years; perform the following procedure:

1. Verify that power is off.
2. Open the top cover by removing the philips screws.
3. Cut the tie wraps holding the battery.
4. Unplug the plastic moxex connector that connects the battery to the PC board.
5. Replace the battery and tie wraps with the same or equivalent.

Reverse the procedure to reinstall the battery.

Repair

For assistance with your DiamondBack system, contact Telecast Fiber Systems, Inc. at 508-754-4858. To return a unit for repair, you must obtain a return material authorization (RMA) number from Telecast service.

Accessory List

The following accessories are available from Telecast:

- Optical power meter
- Cable/connector repair kit
- Loop-back cable to localize signals during installation test
- Replacement Ni-Cad battery pack
- Prefabricated cables built to custom lengths

Troubleshooting

Symptoms	Possible Cause	Corrective Action
No operation, all indicators off.	Power switch is off or the DC power source is inactive.	Turn power switches ON to both units. Verify that the external power supply is delivering between 13.8 and 24 VDC.
Internal LED off.	Battery is depleted and the power switch is off.	Turn power switches ON to both units. Recharge the battery.
Internal LED red.	External power loss or depletion of the internal reserve battery.	Verify external power. The LED illuminates green after 30 minutes of use with the AC power adapter. If the light does not turn green, replace the battery.
No operation, Status LED red, fiber 1 LED and fiber 2 LED alternately flashing.	Optical communication failure or power to the TX is off.	Verify the following: <ul style="list-style-type: none"> • TX power switch is in the on position and the power indicator is illuminated. • Fibers are not broken or disconnected. • Fiber end tips are clean. • Optical connectors are properly mated. • Link loss budget has not been exceeded: The measured optical power* at the RX unit should be > - 21 dBm. * When using an optical power meter.
Internal reserve battery fails quickly.	Reserve battery is not charged or has failed.	Connect to the 13.8 to 24 VDC power source for 16 hours. Replace the battery if charging is not successful.
System failure when external power is removed.	Reserve battery is dead or disconnected.	Check the battery connection. If okay, replace the battery.
RX alarm sounds. Power LEDs green Status LED green Fiber 1 or Fiber 2 illuminated LED has switched to the other fiber.	Failure of one of the redundant optical paths. If only one fiber is used, this may also indicate intermittent optical communication.	Use an optical power meter to verify that both transmitter optical ports are functioning; measured optical power should be approximately - 6 dBm. Check for bad fibers or optical splices. Operation may be restored to the original fiber after repair by pressing the Select switch.
Video is distorted or unavailable on the Receiver output port(s), or no data communication for the ADDER 161 operation.	Video/Data switches are in the wrong positions.	Verify the video/data switch settings for the signals being transmitted.

Specifications

Optical

Wavelength	1300 nm, 1550 nm or 1550 nm DFB (optional), designated at time of purchase.	
Fiber	Single mode over a maximum of 30 km.	
Optical Data Rate	1.47 Gb/s	
Optical Source	Laser diode	
Fiber Types	Single mode. Consult the factory concerning multimode fiber.	
Wavelength	1300 nm, 1550 nm (optional)	
Link Margin	15 dB	
Distance		
	@1300 nm	30 km maximum
	@1550 nm	5 km (dispersion limited) maximum
	@1550 nm dFB	60 km maximum

Video and Data

NTSC and PAL signals at any of the 8 signal channels when switched to video. Adder data at any of the 8 signal channels when switched to data position.

Interface	RS-170, NTSC, PAL
Input/Output Impedance	75Ω
Video Signal to Noise Ratio	> 50 dB
Frequency Response (5 Hz to 6 MHz)	± 0.5 dB
Differential Gain	≤ 2%
Differential Phase	≤ 2°
Chrom-Lum Display	<15 nS NTSC, <25 nS PAL

Power Requirements

Voltage:	12 to 24 VDC
Current:	2.0 Amp maximum
Power:	<20 watts

Note: Although the units will operate at 12 VDC, 13.8 VDC is required to charge the internal UPS battery. Absolute maximum voltage is 30 VDC. Equipment damage may occur at higher voltages.

Mechanical/Environmental

Dimensions (L x W x H)	16.7" x 10.5" x 1.75"
Weight, each unit	5 lbs
Connectors	
Electrical	BNC
Optical	ST (standard), SC/APC (optional)
Temperature Range	- 40 ∞C to + 55 ∞C
Humidity Range	0 to 95%, non-condensing

Warranty

LIMITED WARRANTY STATEMENT

Telecast Fiber Systems, Inc. ("Telecast") expressly warrants to Buyer that the Products supplied shall be free from defects in materials and workmanship for a period of 12 months following the date the Products are delivered to Buyer (the "Warranty Period"). Telecast's liability under this limited warranty shall be limited, at its option, to providing refund of purchase price for Products, or replacing or repairing Products shown to be defective either in materials or workmanship. Buyer's sole and exclusive remedy for breach of warranty shall be such refund, replacement or repair.

A claim of defect in materials or workmanship in any Product shall be allowed only when it is submitted in writing to Telecast Fiber Systems, Inc. within seven days after discovery of the defect, and in any event within the Warranty Period. No claim shall be allowed in respect of any Product which has been altered, neglected, damaged or stored in any manner which adversely affects it. In order to obtain service under the terms of this warranty, Distributor's customer or Distributor must notify Telecast of the defect prior to the expiration of the applicable warranty period and obtain a Return Authorization Number from Telecast. In no event may products be returned to Telecast or to Distributor for warranty service without having obtained from Telecast a Return Authorization Number.

This limited warranty applies only to new and unused Products delivered to Buyers located within the United States of America, or to international Buyers if sold through an authorized Distributor organization, and shall not extend to any equipment not manufactured by Telecast Fiber Systems, Inc., even though such equipment may be sold or operated with the Products. In addition, this limited warranty shall be void and of no further force or effect whatsoever if the Product is repaired or modified by any person other than an authorized representative of Telecast Fiber Systems, Inc. without the consent of Telecast Fiber Systems, Inc. This warranty shall not apply to any defect, failure or damage caused by improper use or inadequate maintenance and care. Nor shall this warranty apply to any damage caused in whole or in part by attempts by personnel other than Telecast's personnel, as approved in advance in accordance with the foregoing provisions, to open, install, repair, or service the Product; nor to damage resulting from improper connection with incompatible equipment; nor to damage to a unit which has been modified by personnel other than Telecast personnel.

Products returned to Telecast for warranty service shall be shipped, freight prepaid to Telecast. Telecast will return the repaired product or ship a replacement, freight prepaid, to either Distributor or Distributor's customer, as requested by Distributor's customer, at a location within the United States or, at Telecast's option, to Distributor's location in the case of international sales.

This limited warranty shall also apply to Products that replace defective Products and Products that have been repaired by authorized representatives of Telecast Fiber Systems, Inc., but only for the original Warranty Period. The Warranty Period shall not be extended by reason of defect, or any period of time during which the Product is not available to Buyer because of defects or repairs, without the express written consent of Telecast Fiber Systems, Inc.

EXCEPT FOR THE EXPRESS LIMITED WARRANTY AGAINST DEFECTS IN MATERIALS AND WORKMANSHIP CONTAINED HEREIN, TELECAST FIBER SYSTEMS, INC. MAKES NO WARRANTY OF ANY KIND WHATSOEVER, EXPRESS OR IMPLIED, AND ALL WARRANTIES OF MERCHANTABILITY, FITNESS FOR A PARTICULAR PURPOSE, AND OTHER WARRANTIES OF WHATEVER KIND ARE HEREBY DISCLAIMED BY TELECAST FIBER SYSTEMS, INC. THIS LIMITED WARRANTY SETS FORTH EXCLUSIVELY ALL OF TELECAST FIBER SYSTEMS, INC.'S LIABILITY IN CONTRACT OR OTHERWISE IN THE EVENT OF A DEFECTIVE PRODUCT.

WITHOUT LIMITATION ON THE FOREGOING, TELECAST FIBER SYSTEMS, INC. EXPRESSLY DISCLAIMS ANY LIABILITY WHATSOEVER FOR ANY DAMAGES INCURRED DIRECTLY OR INDIRECTLY IN CONNECTION WITH THE SALE OR USE OF, OR OTHERWISE IN CONNECTION WITH, THE PRODUCT, INCLUDING WITHOUT LIMITATION, LOSS OF PROFITS AND SPECIAL, INCIDENTAL OR CONSEQUENTIAL DAMAGES, WHETHER CAUSED BY NEGLIGENCE OR OTHERWISE, REGARDLESS WHETHER TELECAST HAS BEEN GIVEN ADVANCE NOTICE OF THE POSSIBILITY THEREOF.

THIS WARRANTY IS GIVEN BY TELECAST IN LIEU OF ANY OTHER WARRANTY EXPRESSED OR IMPLIED.

