



POV™ Systems
Video/Audio/Data Transport Systems

**5422 and 5442
HD-POV Transceiver
System**

User Manual

Telecast Fiber Systems, Inc.
102 Grove Street
Worcester, MA 01605
Tel: 508-754-4858
Fax: 508-752-1520
www.telecast-fiber.com

TABLE OF CONTENTS

| | |
|--|----|
| Laser Safety | 3 |
| A. Introduction | 4 |
| B. Mechanical Configurations | 5 |
| C. Location of Connectors and Switches..... | 6 |
| D. Installing Rack Modules into the V2 Frame..... | 7 |
| E. Power for “Throw-Downs” when frames are not used..... | 7 |
| F. Data and Audio Connections..... | 7 |
| G. Fiber Connections..... | 9 |
| H. Data Switches..... | 10 |
| I. Putting it all Together - Checking Fiber Link Status..... | 10 |
| J. Verifying Signal Presence..... | 11 |
| K. Accessory List..... | 12 |
| L. Specifications | 13 |
| M. Warranty..... | 14 |

LIST OF FIGURES

| | |
|--|----|
| Figure 1:Signal Flow for POV 5241 | 4 |
| Figure 2: Typical System Block Diagram..... | 4 |
| Figure 3: MTR5241 “Throwdown” Module..... | 5 |
| Figure 4: TR5241 “Rack Mount” Module | 5 |
| Figure 5: 5241 Connections | 6 |
| Figure 6: 5241 Rear Panel connections | 6 |
| Figure 7: TR-5241 Pin out Label..... | 8 |
| Figure 8: DB-15 Pin-out..... | 8 |
| Figure 9: DB-25 Pinout..... | 9 |
| Figure 10: Fiber connector options..... | 9 |
| Figure 11: Data Switches | 10 |
| Figure 12: TR5241Rack Mount LED Indicators | 10 |

Laser Safety

WARNING! Class 1 Laser. Do not stare into connector ports or fibers.

Laser Radiation

The unit uses a CDRH Class 1 laser device. Although this means it is eye safe, you must avoid looking directly at, or staring into, the laser beam located on any connector or on the end of a fiber.

Infrared radiation is produced at the fiber connector and at the end of any terminated optical fibers that are attached to this port. Avoid any direct exposure to the light that comes from these sources.

Do not attempt any type of service to this instrument other than what is instructed in this manual. Refer servicing to Telecast Fiber Systems, Inc.

FCC Part A Manual Notice

This equipment has been tested and found to comply with the limits for a Class-A digital device, pursuant to part 15 of the FCC rules. These limits are designed to provide reasonable protection against harmful interference when the equipment is operated in a commercial environment. This equipment generates, uses and can radiate radio frequency energy and, if not installed and used in accordance with the instruction manual, may cause harmful interference to radio communications. Operation of this equipment in a residential area is likely to cause harmful interference in which case the user will be required to correct the interference at their own expense.

Introduction

The Telecast 5422 and 5442 POV fiber systems are designed to transmit the following signals between the two units on two fiber optic strands:

- 1 HD send from camera side to Base side
- 1 Video (composite NTSC or PAL) each way
- 1 RS-232 stream
- 2 RS-422/485 streams (selectable)
- Up to 4 analog Audio signals in each direction
- 2 GPI/contact closures each way

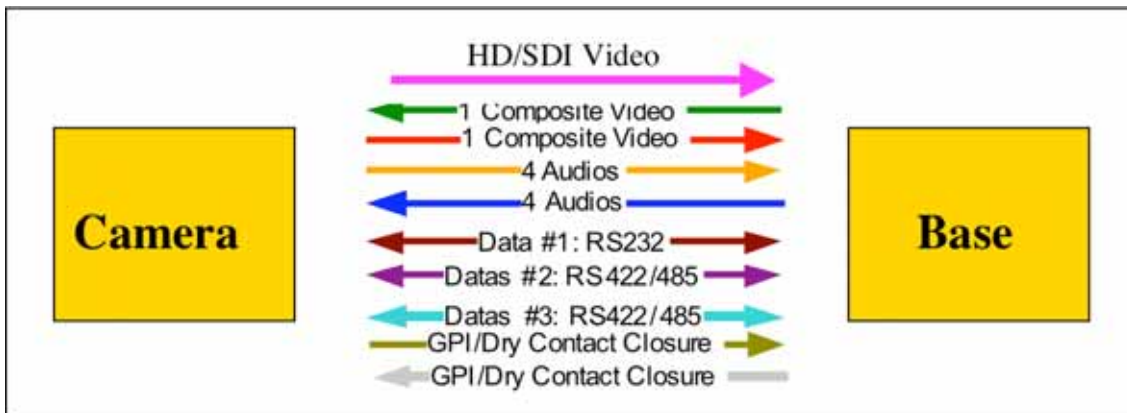

Figure 1: Signal Flow for HD-POV's

A typical system can be seen in Figure #2.

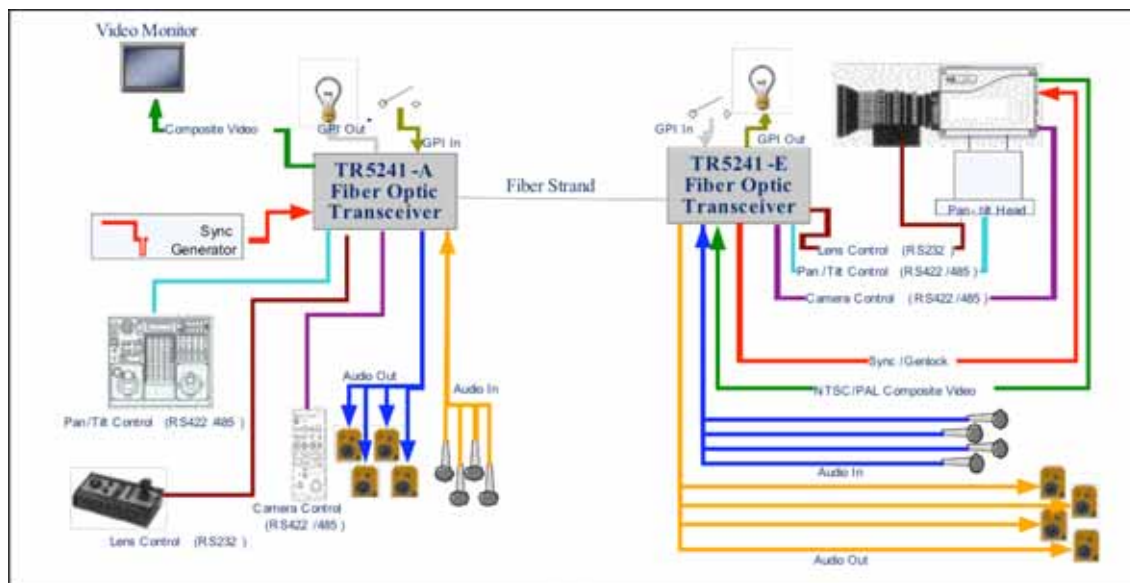

Figure 2: Typical System Block Diagram

The 5442 system utilizes Wave Division Multiplexing (“WDM”) to combine the bidirectional signals onto a single singemode fiber. A ‘system must be comprised of a Camera unit (CA5442-A) unit transmitting at 1300 nm (designated with the “-A” suffix), and a Base unit (BS5442-E) transmitting at 1550nm (designated with the “-E” suffix).

Mechanical Configurations

The POV units can be configured as either a “throw-down” module (MCA5442-A) or a rack-mounted module (CA5442-A), which can be used with a Viper2 frame and power supply. Figure 2 shows these two configurations.



Figure 3:
MCA5442-A “Throwdown” Module

Figure 4:
**BS5442-E “Rack Mount” Module
Shown with Viper 2 Rack Frame**

Location of Connectors and Switches

The POV units are equipped with BNC connectors for the Video signals, and a DB15 and DB25 connector for the Audio, Data and GPI signals. Fiber optic connectivity is achieved through “ST” connectors or, optionally, SC connectors.

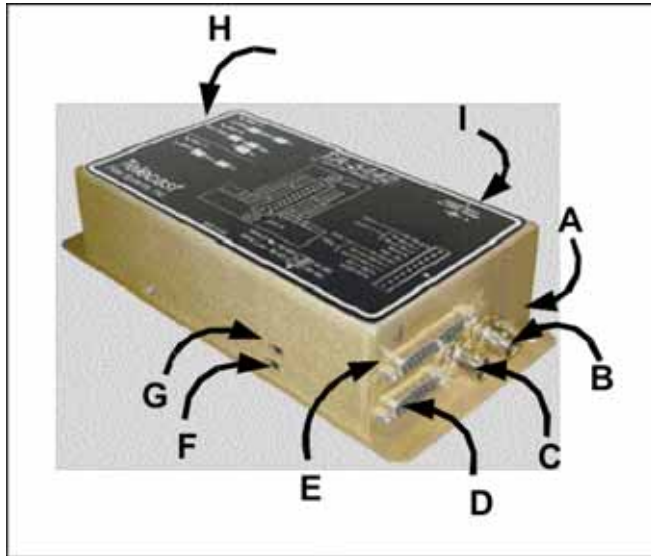

Figure 5:
5241 Connections

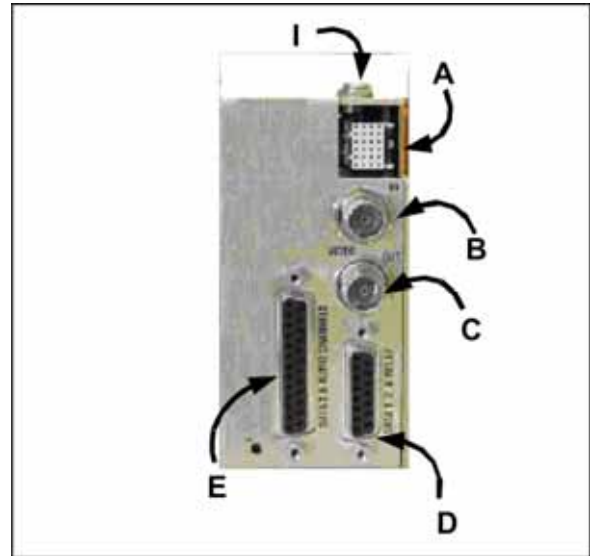

Figure 6:
5241 Rear Panel connections

- A. “Future Bus” Connector** - When configured as a Rack-Mount transceiver, provides electrical connection between the POV unit and the Viper 2 Frame
- B. Video In** – NTSC/PAL Composite Video Input
- C. Video Out** – NTSC/PAL Composite Video Output
- D. DB15 Connector** – Provides pinouts for the following signals:
 - a. Data #1 – RS232
 - b. Data #2 – RS422/485 (user switchable)
 - c. Relay/GPI Input
 - d. Relay/GPI Output
- E. DB25 Connector** – Provides pinouts for the following signals:
 - a. Data #3 – RS422/485 (user switchable)
 - b. Audio In – Four Channels of Line-Level Audio
 - c. Audio Out – Four Channels of Line-Level Audio
- F. Data Channel 2 Format Selection Switch** – Selects between RS422 and RS485 data format for Data Channel 2
- G. Data Channel 3 Format Selection Switch** – Selects between RS422 and RS485 data format for Data Channel 3
- H. Fiber Connector** – ST connector for Fiber Optic cable
- I. External Power Jack** – 2.5mm locking connector for use with external power supply. See Section E, below.

Installing Rack Modules into the V2 Frame

Locate the top and bottom plastic alignment rails in the V2 frame and insert the module into these rails. Carefully slide the Module into the chassis taking care that the multi-pin “FutureBus” connector fully engages its plug without bending any pins.

All optical and electrical connections are then made at the rear of the V2 Frame.

Power requirements for PS5000 power supply are 100-240VAC. Voltage is selectable from 100 to 240VAC via a fuse block located on the power entry module at the rear of the PS5000. To change the voltage, open the door, remove the fuse block, turn it over and re-insert. The proper voltage range should be indicated in the window when the door is closed. Voltage is factory set at 110VAC.

Power for “Throw-Downs”

The HD-POVs use a 2.5mm locking connector, center-pin positive, for DC power. Power requirements are 12-18VDC @ 1 Amp. The Telecast Power part number is ADAP-AC-02-LC.

Data and Audio Connections

The DB-15 Connector (Figures 5/6, “D”) has connections for one RS-232 path (“DATA 1”) and one RS422/485 path (“DATA 2”), as well as the GPI relay contacts.

The optional DB-25 connector (Figures 5/6, “E”) provides contacts for the four bi-directional audio signals and one additional RS422/485 data path (“DATA 3”).

As Datas #2 and #3 can be either RS422 or RS485, the desired data type must be selected using the switches shown in Figure #11, described in the Section H.

Grounds can be made at any of the indicated GND pins.

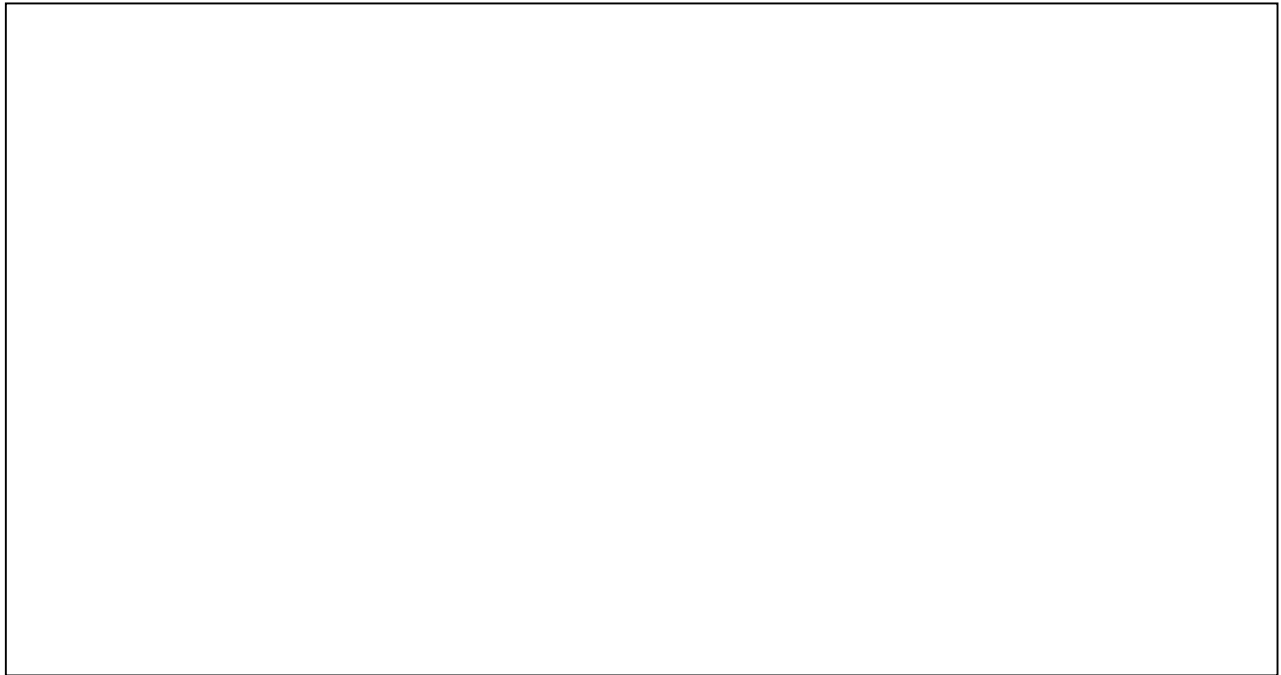

Figure 7: TR-5241 Pin out Label

DB15

Figure 8 shows the pinouts of the DB-15 connector. . Note that RS232 is Data #1, and RS422/485 is Data #2.

| Pin # | | Pin # | |
|-------|------------------------|-------|-----------------|
| 1 | Data 1 RS-232 IN | 9 | Ground |
| 2 | Data 2 RS-422 IN (-) | 10 | Ground |
| 3 | Data 2 RS-422 IN (+) | 11 | Ground |
| 4 | Relay In + | 12 | Ground |
| 5 | Data 1 RS-232 OUT | 13 | N/C |
| 6 | RS-422 OUT/ 485 IO (-) | 14 | Ground |
| 7 | RS-422 OUT/ 485 IO (+) | 15 | Relay Contact B |
| 8 | Relay Contact A | | |

Figure 8: DB-15 Pin-out

DB25

Figure 9 shows Pin-outs for the DB-25 connector (note RS-422/485 In and Out refer to Data #3).

| <u>Pin #</u> | <u>Use</u> | <u>Pin #</u> | <u>Use</u> |
|--------------|---------------------------------|--------------|---------------------------------|
| 1 | Audio 1 IN (+) | 14 | Audio 1 IN (-) |
| 2 | Audio 2 IN (+) | 15 | Audio 2 IN (-) |
| 3 | Audio 3 IN (+) | 16 | Audio 3 IN (-) |
| 4 | Audio 4 IN (+) | 17 | Audio 4 IN (-) |
| 5 | GROUND | 18 | GROUND |
| 6 | Audio 1 OUT (-) | 19 | Audio 1 OUT (+) |
| 7 | Audio 2 OUT (-) | 20 | Audio 2 OUT (+) |
| 8 | Audio 3 OUT (-) | 21 | Audio 3 OUT (+) |
| 9 | Audio 4 OUT (-) | 22 | Audio 4 OUT (+) |
| 10 | GROUND | 23 | GROUND |
| 11 | Data 3: RS-422 IN (+) | 24 | DATA GROUND |
| 12 | Data 3: RS-422 IN (-) | 25 | Data 3: 422 OUT/ 485 IN/OUT (+) |
| 13 | Data 3: 422 OUT/ 485 IN/OUT (-) | | |

Figure 9: DB-25 Pinout

Fiber Connections

Depending on how your system was ordered, you might have 2 different fiber optic connectors. The system requires two singlemode fibers. Figure 10 shows the two available connector types

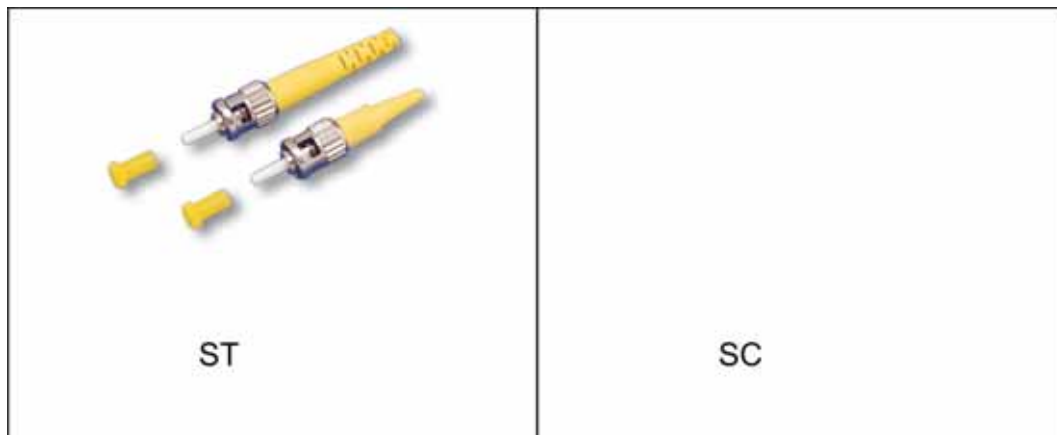

Figure 10: Fiber connector options

Data Switches

Data Channels #2 and #3 can be configured independently to transport either RS422 or RS485 data. Configuration is done via data selection switches as seen in Figure 11 below.

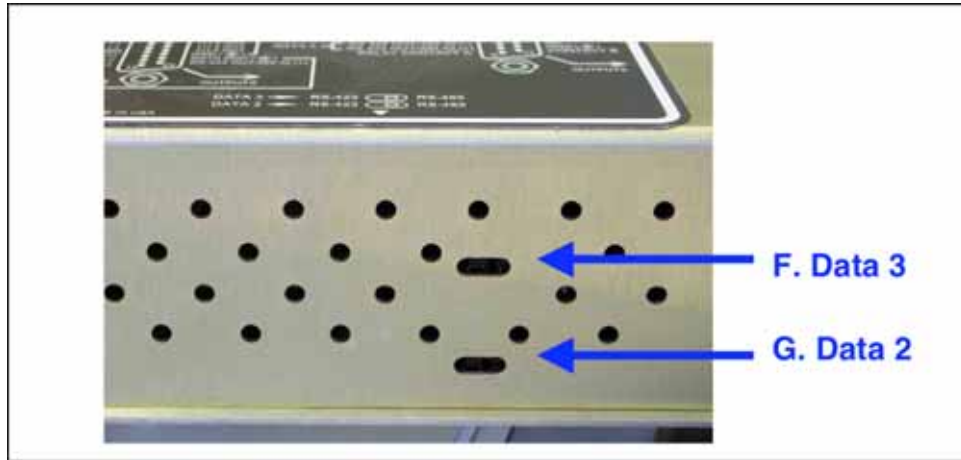

Figure 11: Data Switches

Putting it all Together - Checking Fiber Link Status

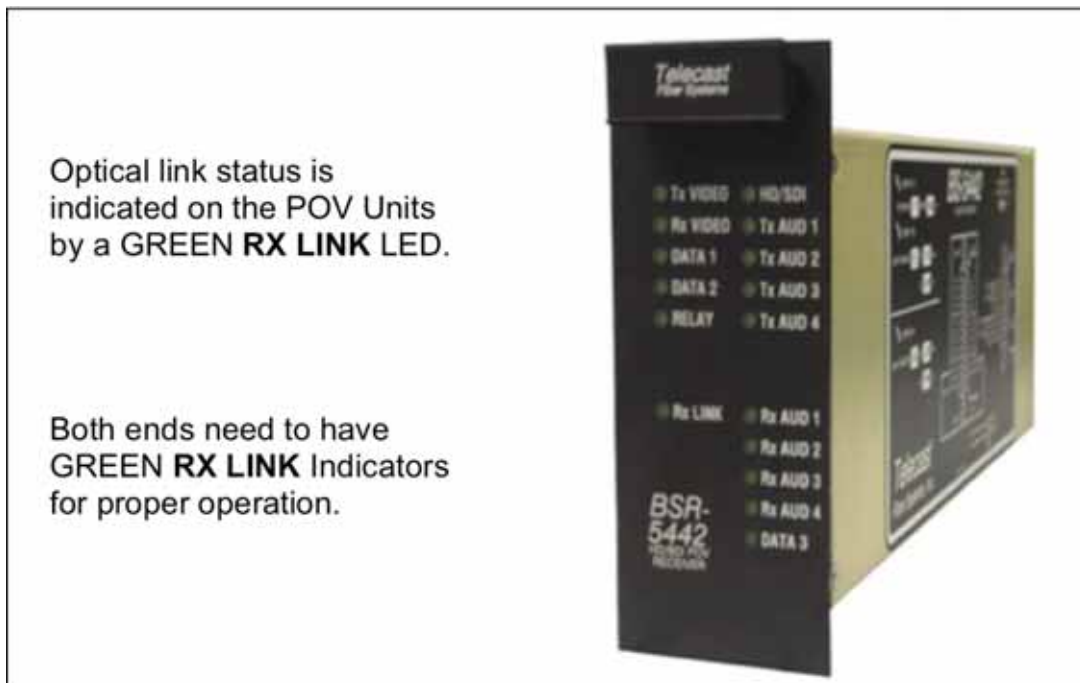

Figure 12: BS5442-E Rack Mount LED Indicators

J. Verifying Signal Presence

Video presence is indicated by a solid green **TX VIDEO** LED.

All audio LEDs will flash in relation to inputted or received audio level.

Data LEDs will flash as data is transmitted or received.

The **RELAY** LED will glow green when its pins are shorted together.

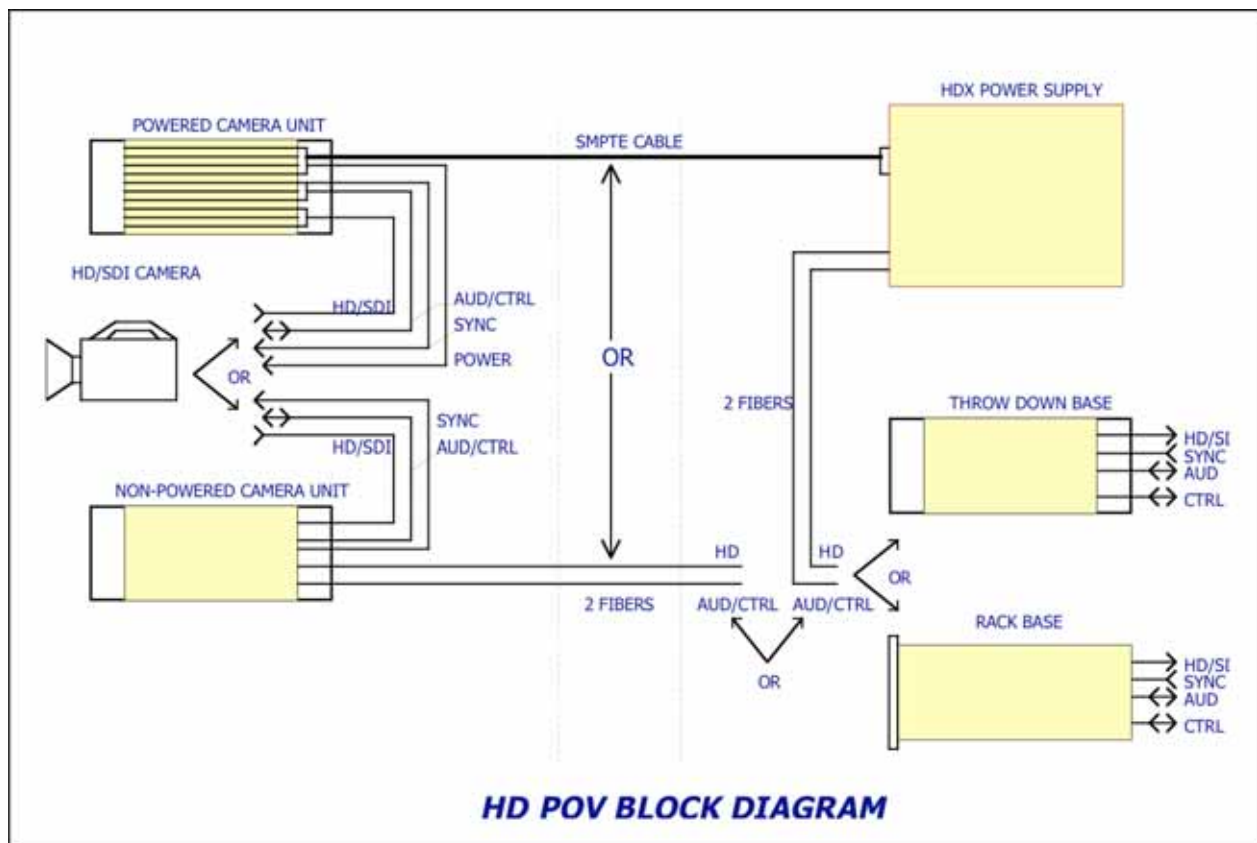

K. Accessory List

| | |
|--------------------------|-----------|
| Viper II Frame | V2Frame-1 |
| Power Supply | PS5000 |
| Battery backup | PS5010 |
| Single wide filler plate | BP5001 |
| Double wide filler plate | BP5002 |

For “throw down” units:

| | |
|--------------------------|---------------|
| Portable DC power supply | ADAP-AC-02-LC |
|--------------------------|---------------|

Note that unlike other Viper 2 modules, conversion from rack mount to “Throw Down” is NOT possible by the user.

Also available are various fiber assemblies and test fibers as well as test instruments such as optical power meters.

L. Specifications

Environment

| | |
|-------------------------|-------------------------|
| Dimensions- (L x W x H) | 8.7" x 3.9" x 2" |
| Weight | 1 lb. |
| Temperature Range | -40 C to +65 C |
| Humidity Range | 0 to 95% non-condensing |

Connectors

| | |
|-------------------------|-------------------------------|
| Electrical (Data/Audio) | DB-25 Female |
| Video (analog/SDI) | BNC |
| Optical | As configured (ST/SC/HDLC/MX) |

Input Voltage

12-18VDC

Power Consumption

Less than 20 Watts

Video, Analog

| | |
|---------------------------------|-------------------------|
| Interface | RS170, NTSC, PAL, SECAM |
| Input/Output Level | 1 Vp-p, 75 Ohms |
| Frequency Response | |
| 30Hz-5MHz | ±0.15 dB |
| -3dB point, min. | >10MHz |
| Signal to Noise Ratio, weighted | >70 dB |
| Differential gain | <1% |
| Differential phase | <0.7° |
| Line Time Distortion | <0.5 IRE |
| Chrominance-Luminance Intermod. | <0.5% |

Audio

| | |
|-----------------------------|------------------------|
| Input/Output Impedance | 10 kΩ/30 Ω |
| Frequency Response | ±0.2 dB, 20Hz to 20kHz |
| Audio Signal to Noise Ratio | > 95 dB, A-weighted |
| Total Harmonic Distortion | < 0.1% |

Data/Auxiliary

| | |
|----------------------------|----------------------------|
| RS422 or RS485, selectable | 0 to 1 Mbaud |
| RS232 | 0 to 150 kbaud |
| Jitter | <33 nsec |
| Contact Closure | Normally Open, Form 1 SPST |

Representative Fiber Specifications

| | |
|----------------------|--|
| Fiber Type | Single Mode (SM) 9/125μ for 5241 Singlemode OR Multimode (mm) 50/125 for 5242 |
| Attenuation Factor | 0.5 dB/km @ 1300 nm |
| Recommended Distance | <5 km |

M. Warranty

LIMITED WARRANTY STATEMENT

Telecast Fiber Systems, Inc. ("Telecast") expressly warrants to Buyer that the Products supplied shall be free from defects in materials and workmanship for a period of 12 months following the date the Products are delivered to Buyer (the "Warranty Period"). Telecast's liability under this limited warranty shall be limited, at its option, to providing refund of purchase price for Products, or replacing or repairing Products shown to be defective either in materials or workmanship. Buyer's sole and exclusive remedy for breach of warranty shall be such refund, replacement or repair.

A claim of defect in materials or workmanship in any Product shall be allowed only when it is submitted in writing to Telecast Fiber Systems, Inc. within seven days after discovery of the defect, and in any event within the Warranty Period. No claim shall be allowed in respect of any Product which has been altered, neglected, damaged or stored in any manner which adversely affects it. In order to obtain service under the terms of this warranty, Distributor's customer or Distributor must notify Telecast of the defect prior to the expiration of the applicable warranty period and obtain a Return Authorization Number from Telecast. In no event may products be returned to Telecast or to Distributor for warranty service without having obtained from Telecast a Return Authorization Number.

This limited warranty applies only to new and unused Products delivered to Buyers located within the United States of America, or to international Buyers if sold through an authorized Distributor organization, and shall not extend to any equipment not manufactured by Telecast Fiber Systems, Inc., even though such equipment may be sold or operated with the Products. In addition, this limited warranty shall be void and of no further force or effect whatsoever if the Product is repaired or modified by any person other than an authorized representative of Telecast Fiber Systems, Inc. without the consent of Telecast Fiber Systems, Inc. This warranty shall not apply to any defect, failure or damage caused by improper use or inadequate maintenance and care. Nor shall this warranty apply to any damage caused in whole or in part by attempts by personnel other than Telecast's personnel, as approved in advance in accordance with the foregoing provisions, to open, install, repair, or service the Product; nor to damage resulting from improper connection with incompatible equipment; nor to damage to a unit which has been modified by personnel other than Telecast personnel.

Products returned to Telecast for warranty service shall be shipped, freight prepaid to Telecast. Telecast will return the repaired product or ship a replacement, freight prepaid, to either Distributor or Distributor's customer, as requested by Distributor's customer, at a location within the United States or, at Telecast's option, to Distributor's location in the case of international sales.

This limited warranty shall also apply to Products that replace defective Products and Products that have been repaired by authorized representatives of Telecast Fiber Systems, Inc., but only for the original Warranty Period. The Warranty Period shall not be extended by reason of defect, or any period of time during which the Product is not available to Buyer because of defects or repairs, without the express written consent of Telecast Fiber Systems, Inc.

EXCEPT FOR THE EXPRESS LIMITED WARRANTY AGAINST DEFECTS IN MATERIALS AND WORKMANSHIP CONTAINED HEREIN, TELECAST FIBER SYSTEMS, INC. MAKES NO WARRANTY OF ANY KIND WHATSOEVER, EXPRESS OR IMPLIED, AND ALL WARRANTIES OF MERCHANTABILITY, FITNESS FOR A PARTICULAR PURPOSE, AND OTHER WARRANTIES OF WHATEVER KIND ARE HEREBY DISCLAIMED BY TELECAST FIBER SYSTEMS, INC. THIS LIMITED WARRANTY SETS FORTH EXCLUSIVELY ALL OF TELECAST FIBER SYSTEMS, INC.'S LIABILITY IN CONTRACT OR OTHERWISE IN THE EVENT OF A DEFECTIVE PRODUCT.

WITHOUT LIMITATION ON THE FOREGOING, TELECAST FIBER SYSTEMS, INC. EXPRESSLY DISCLAIMS ANY LIABILITY WHATSOEVER FOR ANY DAMAGES INCURRED DIRECTLY OR INDIRECTLY IN CONNECTION WITH THE SALE OR USE OF, OR OTHERWISE IN CONNECTION WITH, THE PRODUCT, INCLUDING WITHOUT LIMITATION, LOSS OF PROFITS AND SPECIAL, INCIDENTAL OR CONSEQUENTIAL DAMAGES, WHETHER CAUSED BY NEGLIGENCE OR OTHERWISE, REGARDLESS WHETHER TELECAST HAS BEEN GIVEN ADVANCE NOTICE OF THE POSSIBILITY THEREOF. THIS WARRANTY IS GIVEN BY TELECAST IN LIEU OF ANY OTHER WARRANTY EXPRESSED OR IMPLIED.