

DENSITÉ series

WDA-1001

Word Clock Distribution Amplifier

Guide to Installation and Operation

M451-9300-100

22 Dec 2009



Miranda

Technologies Inc.

3499 Douglas-B.-Floreani
St-Laurent, Québec, Canada H4S 1Y6

Tel. 514-333-1772

Fax. 514-333-9828

www.miranda.com

© 2009 Miranda Technologies Inc.

Compliance Information

Electromagnetic Compatibility

- This equipment has been tested for verification of compliance with FCC Part 15, Subpart B, Class A requirements for Digital Devices.
- This equipment complies with the requirements of:
 - EN 55022 Class A, Radiated Emissions.
 - EN 55022 Class A, Conducted Emissions
 - EN 61000-4-2, -3, -6, -11 Electromagnetic Immunity
 - EN 61000-3-2 & -3-3, Electromagnetic Disturbance in Supply Systems

How to contact us:

For technical assistance, please contact the Miranda Technical support centre nearest you:

Americas

Telephone:

+1-800-224-7882

e-mail:

techsupp@miranda.com

Asia

Telephone:

+852-2539-6987

e-mail:

asiatech@miranda.com

Europe, Middle East, Africa, UK

Telephone:

+44 (0) 1491 820222

e-mail:

eurotech@miranda.com

China

Telephone:

+86-10-5873-1814

e-mail:

asiatech@miranda.com

France (only)

Telephone:

+33 (0) 1 55 86 87 88

e-mail:

eurotech@miranda.com

Visit our web site at www.miranda.com

Table of Contents

1 WDA-1001 Word Clock Distribution Amplifier 5

 1.1 Introduction 5

 1.2 Features 5

 1.3 Block Diagram 6

 1.4 Front Card-edge Interface 6

2 Installation 7

 2.1 Unpacking 7

 2.2 Installation in the Densité frame 7

 2.3 Rear Connector Panel 7

3 Operation 8

 3.1 Card-Edge Controls and Indicators 8

 3.1.1 Status LED 8

 3.1.2 Gain control 8

 3.2 Local control using the Densité frame control panel 9

 3.2.1 Overview 9

 3.2.2 Menu for local control 10

4 Technical Specifications 12

Table of Figures

Figure 1 - Functional block diagram of the WDA-1001 6

Figure 2 - Card-edge controls and indicators 6

Figure 3 – WDA-1001-DRP Double Rear Connector Panel 7

Figure 4 - Output level measurement location 9

Figure 5 - Densité Frame local control panel 5

GUIDE TO INSTALLATION AND OPERATION

1 WDA-1001 Word Clock Distribution Amplifier

1.1 Introduction

The WDA-1001 is a Word Clock Distribution Amplifier that provides 8 outputs and supports a wide range of clock frequencies and amplitudes. It can fan out AC coupled as well as TTL types of signals because the amplifier maintains an end-to-end DC transparency.

A passive loop-through input is provided to ease distribution of more than 8 Word Clock signals by daisy chaining many WDA-1001 cards.

Alarms can be enabled to monitor signal presence and/or overload conditions with user programmable thresholds.

1.2 Features

- Fans out up to 8 Word Clock signals
- DC Coupled all the way through
- Wide range of amplitudes and frequencies
- Works with both AC-Coupled and TTL/CMOS type of signals
- SDIF-2 Word Clock compliant
- Built-in basic signal probing with programmable thresholds
- Adjustable output level
- Hot-swappable

1.3 Block Diagram

The following block diagram shows the functionality of the WDA-1001.

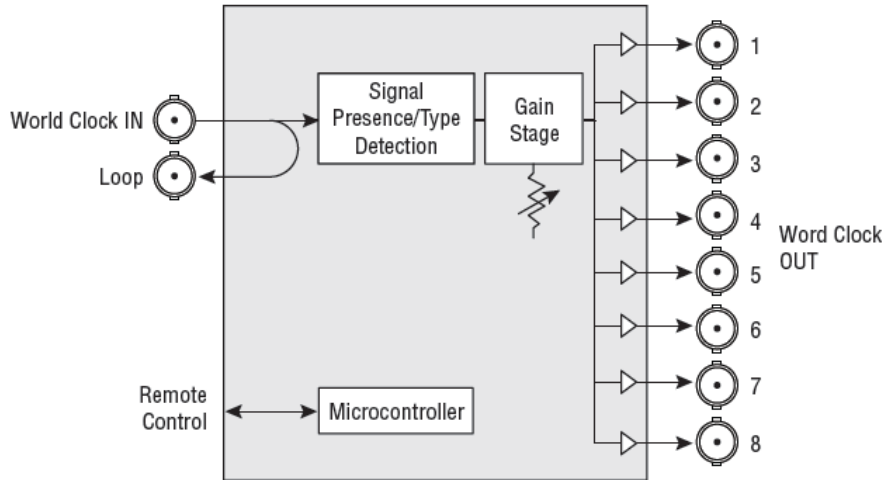

Figure 1 - Functional block diagram of the WDA-1001

1.4 Front Card-edge Interface

The front card-edge of the WDA-1001 incorporates three elements:

- Status LED (see section 3.1)
- Select Button (see section 0)
- Gain control adjustment (see section 3.1.2)

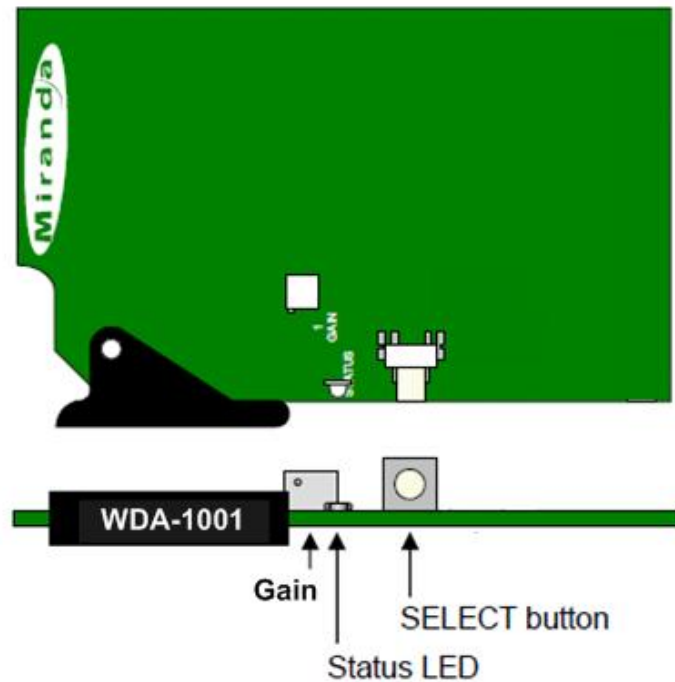

Figure 2 - Card-edge controls and indicators

2 Installation

2.1 Unpacking

Make sure the following items have been shipped with your WDA-1001. If any of the following items are missing, contact your distributor or Miranda Technologies Inc.

For a DENSITÉ-2 frame:

- WDA-1001 Word Clock Distribution Amplifier
- WDA-1001-DRP Rear Panel (see figure below)

For a DENSITÉ-3 frame:

- WDA-1001-3RU Word Clock Distribution Amplifier including 3RU adaptor
- WDA-1001-DRP-3RU Rear Panel including 3RU adaptor

2.2 Installation in the Densité frame

The WDA-1001 and its associated connector rear panel must be mounted in a DENSITÉ-2 or DENSITÉ-3 frame. It is not necessary to switch off the frame's power when installing or removing the card. See the DENSITÉ Frame manual for detailed instructions for installing cards and their associated rear panels.

- This card is sized for DENSITÉ-2, but can be installed in DENSITÉ-3 with the use of available adapters for the card and the rear panel.

2.3 Rear Connector Panel

The WDA-1001 requires a dual-slot rear in the Densité-2 and Densité-3 frames:

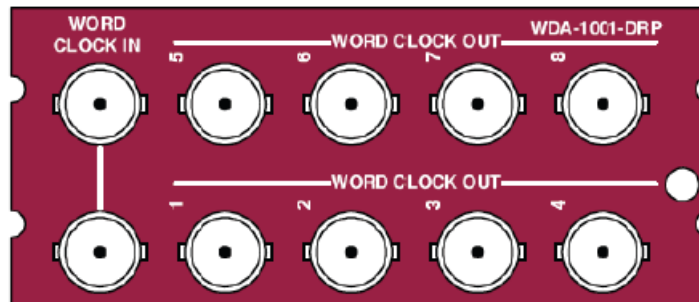

Figure 3 – WDA-1001-DRP Double Rear Connector Panel

With the double-width rear panel installed in a Densité-2 frame, the WDA-1001 must be installed in the right-most of the two slots covered by the panel in order to mate with the panel's connectors.

If it is placed in the wrong slot, the front panel LED will flash red. Move the card to other slot for correct operation. No damage will result to the card if this occurs.

The rear panel provides the following connections:

- Word Clock IN and passive loop-through on BNC connectors
- Word Clock OUT (8) on BNC connectors

3 Operation

3.1 Card-Edge Controls and Indicators

3.1.1 Status LED

The status monitor LED is located on the front card-edge of the WDA-1001, and is visible through the front access door of the DENSITÉ frame. This multi-color LED indicates the status of the WDA-1001 by color, and by flashing/steady illumination.

The chart shows how the various error conditions that can be flagged on the WDA-1001 affect the LED status.

- If a cell is gray, the error condition cannot cause the LED to assume that status
- If more than one LED status is possible for a particular error condition, the status is configurable. See Section 3.2.2 for details.
- The factory default status is shown by a ⊕

The LED will always show the most severe detected error status that it is configured to display, and in the chart error severity increases from left to right, with green representing no error/disabled, and flashing red the most severe error.

Error Condition	LED Status			
	Green	Yellow	Red	Flashing Red
No errors	⊕			
Overload on output			⊕	
No signal detected on input		⊕		
Hardware Failure / No Rear				⊕

If the LED is Flashing Yellow, it means that the card is selected for local control using the Densité frame's control panel. See Section 0 for details.

3.1.2 Gain control

The amplitude Gain can be controlled from the card edge using the gain control pot (see figure 1.2).

- The signal level measured inside the card can be displayed on the Densité frame's local control panel while the gain is being adjusted. See section 3.2.2.

The amplitude level is measured on the card, before the 75 Ohm output serial resistor, and is displayed in V peak above zero (see Figure 4 - Output level measurement location). Therefore the real output level, peak to peak, will be related to the actual output load and to the DC component of the input signal. The following table describes the levels to be expected for different configurations and signal types:

Input signal type	High Impedance output load	75 ohm output load
TTL Signals	The Vp reported value corresponds to the peak-to-peak level of the actual output signal.	The Vp reported value corresponds to twice the peak-to-peak level of the actual output signal.
AC Signals	The Vp reported value corresponds to half of the peak-to-peak level of the actual output signal.	The Vp reported value corresponds to the peak-to-peak level of the actual output signal.

Note: All programmable threshold voltages are also in Vp (V peak).

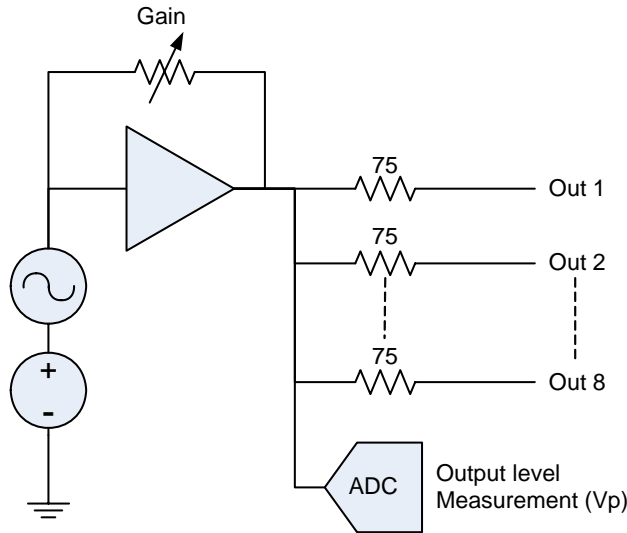

Figure 4 - Output level measurement location

3.2 Local control using the Densité frame control panel

3.2.1 Overview

Push the SELECT button on the WDA-1001 card edge (see Section 1.4) to assign the local control panel to operate the WDA-1001. Use the control panel buttons to navigate through the menu, as described below.

All of the cards installed in a Densité frame are connected to the frame's controller card, which handles all interaction between the cards and the outside world. There are no operating controls located on the cards themselves. The controller supports remote operation via its Ethernet ports, and local operation using its integrated control panel.

The local control panel is fastened to the controller card by a hinged connector, and when installed is located in the front center of the frame, positioned in front of the power supplies. The panel consists of a display unit capable of displaying two lines of text, each 16 characters in length, and five pushbuttons.

The panel is assigned to operate any card in the frame by pushing the SELECT button on the front edge of that card.

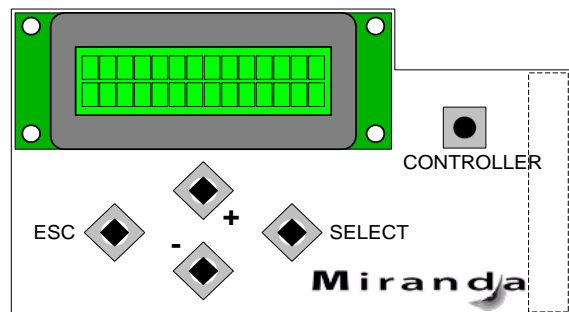

Figure 5 - Densité Frame local control panel

- Pushing the CONTROLLER button on the control panel selects the Controller card itself.
- The STATUS LED on the selected card flashes yellow.

The local control panel displays a menu that can be navigated using the four pushbuttons located beneath the display. The functionality of the pushbuttons is as follows:

[+] [-] Used for menu navigation and value modification

[SELECT] Gives access to the next menu level. When a parameter value is shown, pushing this button once enables modification of the value using the [+] and [-] buttons; a second push confirms the new value

[ESC] Cancels the effect of parameter value changes that have not been confirmed; pushing [ESC] causes the parameter to revert to its former value.

Pushing [ESC] moves the user back up to the previous menu level. At the main menu, [ESC] does *not* exit the menu system. To exit, re-push the [SELECT] button for the card being controlled.

If no controls are operated for 30 seconds, the controller reverts to its normal standby status, and the selected card's STATUS LED reverts to its normal operating mode. If a parameter was changed on the card but not submitted (SELECT was not pressed) and the 30 second timeout occurs, the parameters will be confirmed as if the SELECT key had been pressed.

3.2.2 Menu for local control

The WDA-1001 has operating parameters which may be adjusted locally at the controller card interface.

- Press the SELECT button on the WDA-1001 front card edge to assign the Densité frame's local control panel to the WDA-1001
- Use the keys on the local control panel to step through the displayed menu to configure and adjust the WDA-1001.

Using the menu, the user can:

- Display the error status if any is present
- Display the signal type, AC or DC (TTL-like) and its amplitude (use this while adjusting the gain of the WDA-1001 using the card-edge gain control, as described in section 3.1.2)
- Adjust the **Signal threshold**, to set the level below which a low signal alarm will be flagged
- Adjust the **Overload threshold**, to set the level above which an overload alarm will be flagged
- Configure the **Overload** and **No Signal** alarms, setting the alarm level (color displayed on the front panel status LED, and severity reported to the frame controller) and selecting whether the alarm is to be reported on the frame's GPI interface.

Both alarm thresholds – Overload and Signal Presence – are measured inside the card, before the 75 Ohm output serial resistor, and are given in V peak above zero. Therefore the real Threshold levels will be related to each output load and to the DC component of the input signal – see the table on page 9.

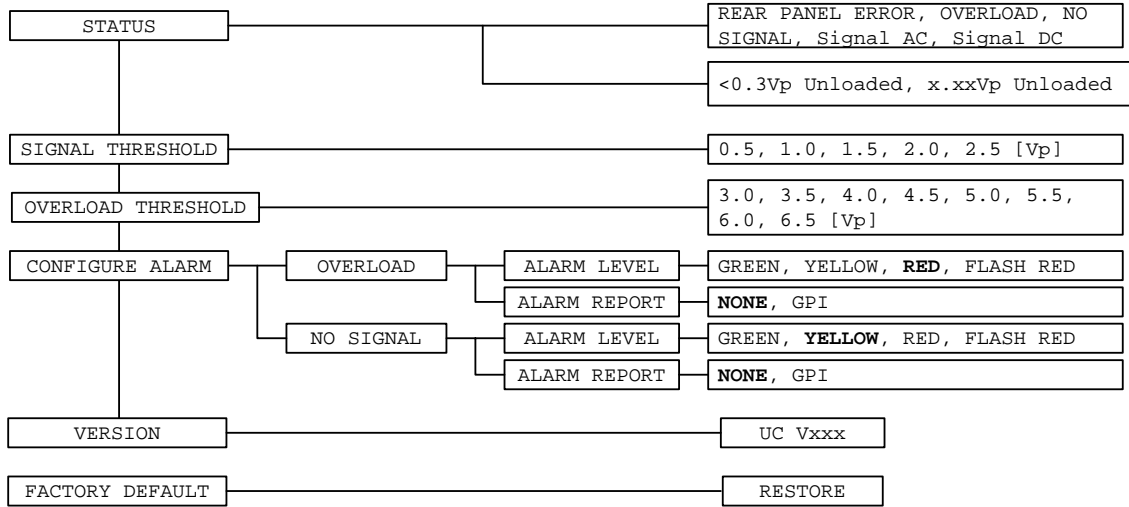

4 Technical Specifications

DC Coupled Distribution Amplifier with 8 Outputs, non-reclocking

INPUT with PASSIVE LOOP

Signal:	Word Clock, TTL or AC-Coupled, SDIF-2
Connectors (2):	BNC
Maximum Input Level:	± 8 V _{peak} maximum
Input impedance:	> 6 kOhm

OUTPUTS (8)

Signal:	Word Clock, DC coupled with Input
Connectors (8):	BNC
Output impedance:	75 Ohm
Output Load:	75 Ohm or more

MAXIMUM OUTPUT LEVELS

With a TTL input signal:	+7 V _p with 1 Kohm load +3.5 V _p with 75 ohm load
With an AC-coupled input signal:	13 V _{pp} with 1 Kohm load 6 V _{pp} with 75 ohm load

PROCESSING

Bandwidth:	32 to 96 kHz
Gain – with >1 kohm load:	-3 to +12 dB
– with 75 ohm load:	-9 to +3 dB
Propagation Delay:	< 50 ns