

# AMX-1881

## Description

The AMX-1881 is a high-quality embedder which embeds up to eight AES 24-bit 48 kHz digital audio signals into a single HD/SD serial digital video signal. It includes audio and video signal presence detection and reporting, and local or remote configuration and control. A unique feature is its ability to embed time code, a serial RS-422 data signal and two GPI status signals into the video signal. The card has built-in audio tone, time code and video color bar test signals.

The AMX-1881 is designed for use in the DENSITÉ frame.

## Video - Features

- Serial HD/SD-SDI input with automatic equalization for up to 110/250 meters of cable.
- Automatic detection of video input format
- Automatic detection of input video loss and switchover to local black for continuity of embedded audio.

## Audio - Features

- AES inputs: either 110  $\Omega$  balanced or 75  $\Omega$  unbalanced, depending on rear panel in use

- Sample rate conversion for asynchronous AES inputs
- Audio input channel gain selectable from -96dB to +12dB by 0.5dB steps
- Audio groups insertion/pass-through/delete
- Selectable audio delay of up to 3 frames in 1/2 frame steps
- Left/Right channels swappable for each AES input
- Automatic mute on AES error
- Selectable routing of AES signals to audio groups
- Dolby-E compatible (48kHz synchronous)
- 24-bit digital audio embedding
- Monitor selector for Densité frame monitor switcher (MSB)

## Embedding Other Signals - Features

- Linear Time Code (LTC) embedding
- RS-422 serial data input for embedding as ANC data.
- Sampling of two GPI inputs for embedding as ANC data.

## FUNCTIONAL BLOCK DIAGRAM

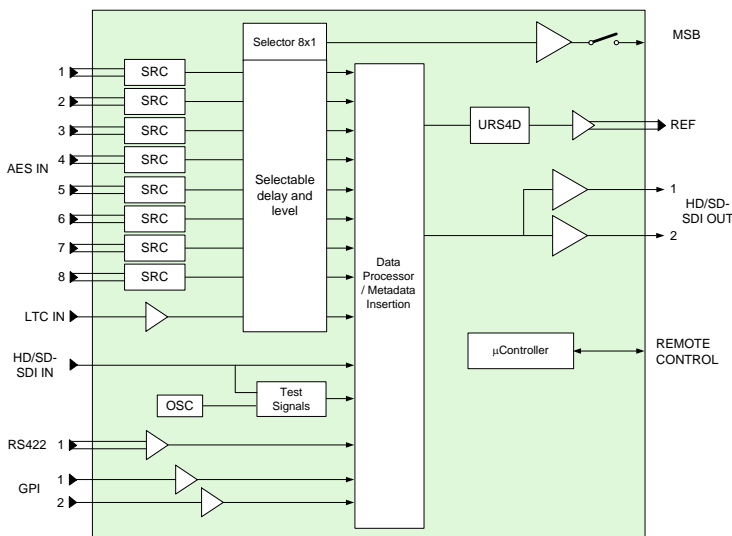

## SPECIFICATIONS

### VIDEO INPUT

Video Signal: HD/SD-SDI  
SMPTE 292M / SMPTE 259M  
(see list of supported formats below)  
Cable Length: up to 110/250 meters of Belden 1694A  
Return Loss: >15 dB, 5 MHz to 1.485 GHz

### AUDIO AES-3id INPUT

Signal: AES-3id (SMPTE 276M)  
Level: 0.2 to 2.0 Vp-p  
Impedance: 75  $\Omega$  unbalanced  
Cable length: >400 m

### AUDIO AES SIGNALS

Sampling Rate: 48kHz synchronous or asynchronous  
Dolby-E Rate: 48kHz synchronous  
Bits: 24-bit

.....(continued)

# AMX-1881 HD/SD 8 AES Embedder Guide to Installation and Operation

## SPECIFICATIONS (cont'd)

### LTC SIGNAL

Signal: LTC per SMPTE 12M  
 Impedance: < 10kΩ (bridging 600Ω) unbalanced  
 Level: 0.3 to 5Vp-p

### VIDEO OUTPUT

Video Signal: HD/SD-SDI  
 (SMPTE 292M / SMPTE 259M)

Audio embedded per  
 SMPTE 299M / SMPTE 272M

LTC embedded as  
 ATC/DVITC  
 (SMPTE RP188/SMPTE 266M)

RS-422 and two GPIs embedded  
 as ANC data per SMPTE 291M  
 (Proprietary DID)

Return Loss: >15 dB up to 1.485 GHz  
 Wideband Jitter: As per SMPTE-259M-C and 292M

### ANC SERIAL DATA INPUT

Signal: RS-422  
 Level: 300 mVpp (min)  
 Rate: 38.400 or 115.200 bauds

### ANC GENERAL PURPOSE INTERFACE (GPI) OUTPUT

Signal (2): Contact closure (opto-isolated),  
 common ground  
 Level: True = 0 to 0.8 V (max.)  
 Maximum input voltage = ±5.5 V  
 Rate: DC to 250 Hz

## PROCESSING PERFORMANCE

Signal Path: 10-bit video / 24-bit audio  
 Video Delay: HD: 4.5 μs / SD: 11.5 μs  
 Audio Processing Delay: 875 μs audio insertion delay ‡‡  
 Audio Delay: Up to 3 video frames (1/2 frame steps)  
 LTC Delay: Up to 3 video frames (one frame steps)  
 RS-422 Processing delay: max 500 μs ‡‡  
 GPI Processing delay: 4 video lines ‡‡  
 Test Signals: Video - color bars 100%  
 Audio - 1 kHz tone (R steady, L pulsed)  
 -18dBFS (EBU R49, R68)  
 LTC – 10 second loop starting at  
 23:59:00:00  
 Power: 7 W

Note ‡‡: Applicable to combinations of this card and ADX-1881.

### List of supported formats:

HD-SDI formats :	1280 x 720/59.94/P
1920 x 1080/59.94/I	1280 x 720/50/P
1920 x 1080/50/I	
1920 x 1080/29.97/P	SD-SDI formats :
1920 x 1080/25/P	525
1920 x 1080/24/P	625
1920 x 1080/23.98/P	
1920 x 1080/29.97/PsF	
(detected as 1920 x 1080/59.94/I)	
1920 x 1080/25/PsF	
(detected as 1920 x 1080/50/I)	
1920 x 1080/24/PsF	
1920 x 1080/23.98/PsF	

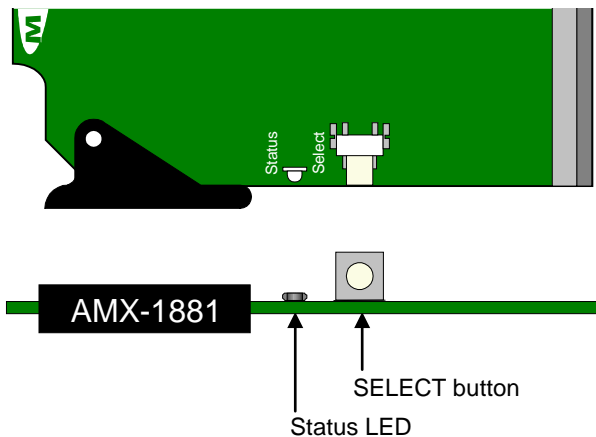

AMX-1881 Front card edge

AMX-1881-75-DRP

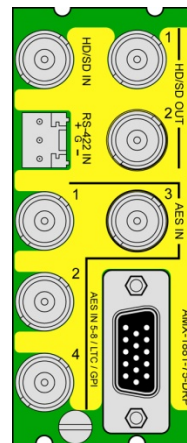

AMX-1881 Breakout Panel

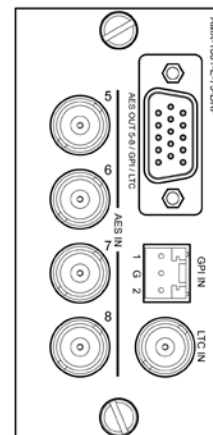

(Note: female 15-pin connectors on both panels)  
 AMX-1881 Rear Connector Panels

# AMX-1881 HD/SD 8 AES Embedder Guide to Installation and Operation

## INSTALLATION

Make sure the following items have been shipped with your AMX-1881. If any of the following items are missing, contact your distributor or Grass Valley.

- \* AMX-1881 HD/SD 8 AES Embedder
- \* AMX-1881 -75-DRP rear panel
- \* AMX-1881 breakout panel
- \* Densité-ext-mount external mounting bracket (one per frame)

The AMX-1881 and its associated rear connector panel must be mounted in a DENSITÉ frame. It is not necessary to switch off the frame's power when installing or removing the AMX-1881. See the DENSITÉ Frame manual for detailed instructions for installing cards and their associated rear panels.

The AMX-1881 has multiple inputs and outputs, and making space for all the necessary connectors at the rear of the frame requires a double-width rear panel.

When a double-width rear panel has been installed, the AMX-1881 must be installed in the right-most of the two slots covered by the panel in order to mate with the panel's connectors. If it is placed in the wrong slot, the front panel LED will flash red. Move the card to other slot for correct operation. No damage will result to the card should this occur.

In addition, the AMX-1881 requires an external mounting bracket and breakout panel. The breakout panel is connected to the rear panel via a multi-conductor cable fitted with two male connectors. The AMX-1881's inputs and outputs occupy both panels.

See the annex at the end of this manual for the specification of the cable to interconnect the rear panel and the breakout panel.

## OPERATION

### Overview

The DENSITÉ frame incorporates a central controller card, located in the center of the frame, which is equipped with an LCD display and a control panel. The controller handles error reporting and local and remote control for all cards installed in the frame. The display and control panel are assigned to the card in the frame whose SELECT button has been pushed.

### Status Monitor LED

The status monitor LED is located on the front card-edge of the AMX-1881 module, and is visible through the front access door of the DENSITÉ frame. This multi-color LED indicates module status by color, and by flashing/steady illumination, according to the following chart (which also indicates fault reporting for this card on the DENSITÉ frame's serial and GPI interfaces).

	REPORT		COLOR (F=flashing)			
	SERIAL	GPI	G	Y	R	FR
No errors			*			
No signal	*					*
No rear						*
Test mode				*		

\* : Factory default.     User configurable

A "Flashing Yellow" Status LED indicates that the SELECT button on the front panel has been pushed, and the controller display and control panel are now assigned to this card. The LED color assignments for some error

conditions can be reconfigured by the user (see the chart and menu for details).

### User Interface

Pushing the SELECT button will cause the on-card STATUS LED to flash yellow, and the card identification and the current status will be shown on the controller card's display. The STATUS LED will revert to it's normal state upon a second push of the button, or after a short delay. The messages which may appear are shown in the top line of the menu chart on page 4.

### Example :

SELECT button pushed twice when there is no input signal connected to the rear panel and the LED is steady red:

A	M	X	-	1	8	8	1								
N	O	S	I	G	N	A	L								

Use the local control panel to access the detailed status report shown in the STATUS menu on page 4.

### Operating Parameter Adjustment

The AMX-1881 has operating parameters which may be adjusted at the controller card interface. After pressing the SELECT button on the AMX-1881 card, use the keys on the local control panel (described in the Controller card manual) to step through the displayed menu and adjust the parameters. The menus are shown below.

# AMX-1881 HD/SD 8 AES Embedder Guide to Installation and Operation

## AMX-1881 Menu

				Applies to	
				HD	SD
STATUS	NO REAR/ NO SIGNAL/ 720p50/ 720p60/ 720p59.94/ 1080p24/ 1080p24sF/ 1080p23.98/ 1080p23.98sF/ 1080p25/ 1080i50/ 1080i29.97/ 1080i59.94/ 625/ 525			•	•
AUDIO GROUPS	NONE/ 1234			•	•
AES IN	NONE/ 1234			•	•
LTC IN	NONE/ PRESENT			•	•
AES IN 1		BITS	16 BIT / 20 BIT / 24 BIT / OTHER		
		MODE	N.I. / 2 CHANNEL / 1 CHANNEL / P/S / STEREO		
		EMPHASIS	N.I. / NONE / 50 / 15-us / J.17		
		USE	CONSUMER / PROFESSIONAL		
		ENCODING	LINEAR PCM / NON PCM		
AES IN 2	Same as AES IN 1			•	•
AES IN 3	Same as AES IN 1				
AES IN 4	Same as AES IN 1				
AES IN 5	Same as AES IN 1				
AES IN 6	Same as AES IN 1				
AES IN 7	Same as AES IN 1				
AES IN 8	Same as AES IN 1				
AFD		PRESENCE	NONE / PRESENT	•	•
		FORMAT	4:3_0 / ... / 16:9_5		•
			16:9_0 / ... / 16:9_5	•	
VLI		PRESENCE	NONE / PRESENT		•
		FORMAT	4:3_0 / ... / 16:9_5		•
DOLBY METADATA	NONE/ PRESENT			•	•
USER PRESET**		LOAD	[ 1, 2, 3, 4, 5 ]	•	•
		SAVE	[ 1, 2, 3, 4, 5 ]	•	•
INPUT SOURCE**		GROUP 1	[ AES IN 1-2, AES IN 3-4, AES IN 5-6, AES IN 7-8, PASS, DELETE ]		
		GROUP 2	[ AES IN 1-2, AES IN 3-4, AES IN 5-6, AES IN 7-8, PASS, DELETE ]		
		GROUP 3	[ AES IN 1-2, AES IN 3-4, AES IN 5-6, AES IN 7-8, PASS, DELETE ]	•	•
		GROUP 4	[ AES IN 1-2, AES IN 3-4, AES IN 5-6, AES IN 7-8, PASS, DELETE ]		
CONFIG AES**		AES IN 1			
		LEVEL	LEFT [MUTE, -95.5 dB, ..., 0 dB, ..., 12dB]		
			RIGHT [MUTE, -95.5 dB, ..., 0 dB, ..., 12dB]		
			LOCK [OFF, ON]		
		PHASE INVERT	LEFT [OFF, ON]		
			RIGHT [OFF, ON]		
		MUTE L&R	[OFF, ON]		
		SWAP L&R	[OFF, ON]		
		SAMPLE RATE CONV	[OFF, AUTO]	•	•
AES IN 2	Same as AES IN 1				
AES IN 3	Same as AES IN 1				
AES IN 4	Same as AES IN 1				
AES IN 5	Same as AES IN 1				
AES IN 6	Same as AES IN 1				
AES IN 7	Same as AES IN 1				
AES IN 8	Same as AES IN 1				
DELAY	[NONE, 0.5 FRAME, 1.0 FRAME, 1.5 FRAME, 2.0 FRAME, 2.5 FRAME, 3.0 FRAME]			•	•
EMBED BITS	[20 BIT, 24 BIT]				•

(continued).....

# AMX-1881 HD/SD 8 AES Embedder Guide to Installation and Operation

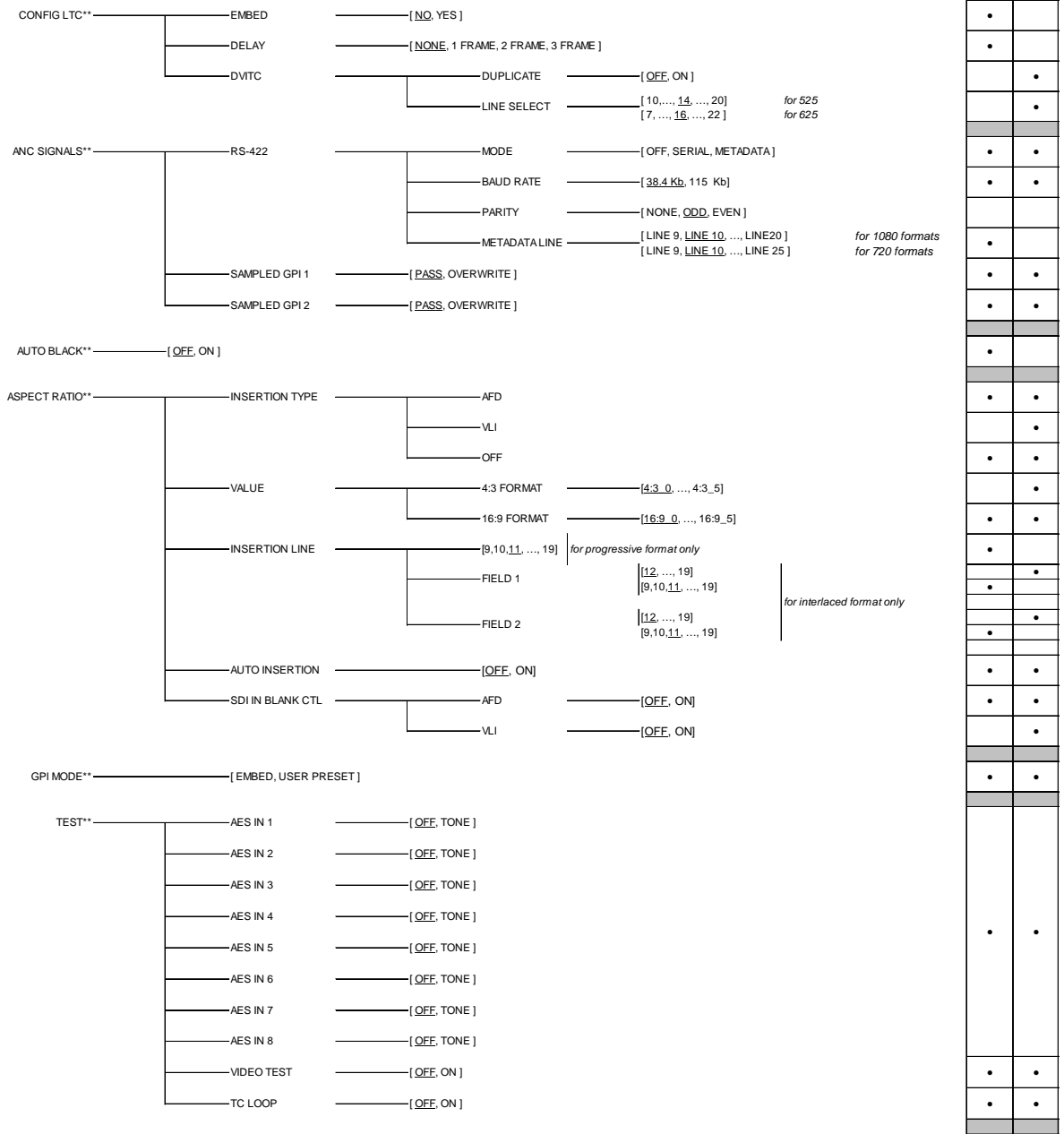

(continued)....

# AMX-1881 HD/SD 8 AES Embedder Guide to Installation and Operation

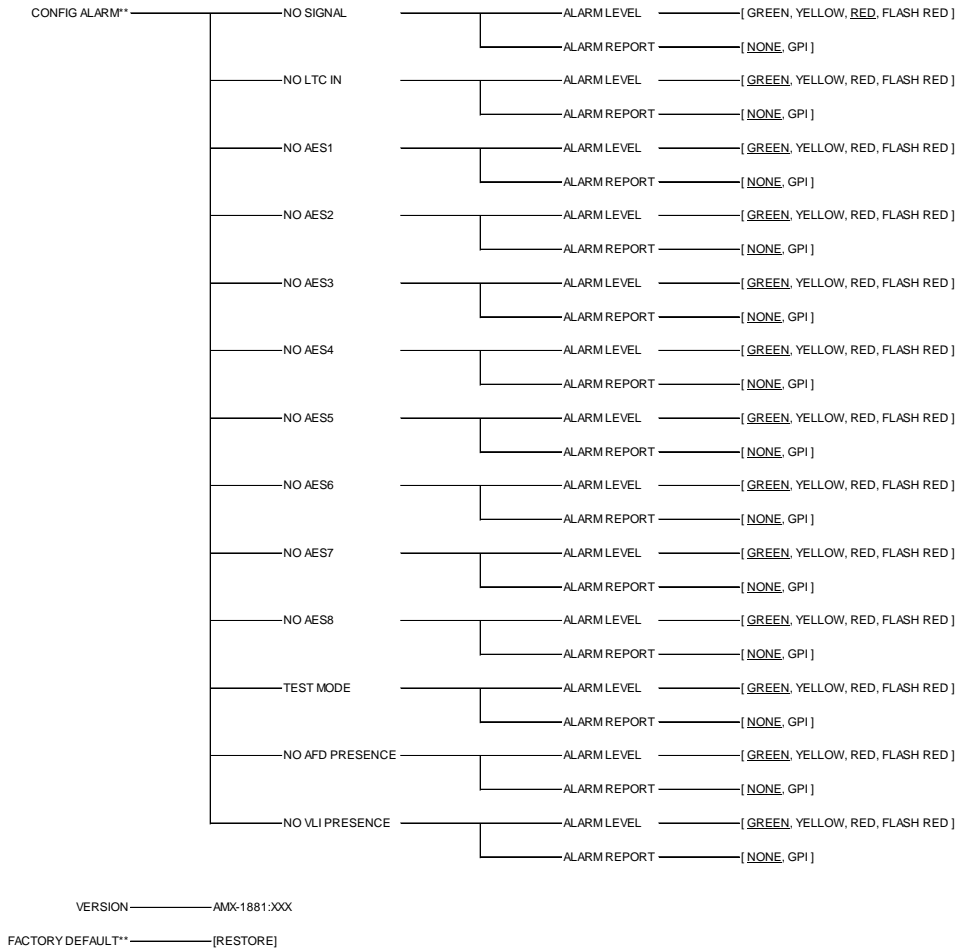

		•	•
		•	•
		•	•
		•	•
		•	•
		•	•
		•	•
		•	•
		•	•

\*\* Press Select pushbutton to activate selection.

[ ] list of available parameter values.

Underlined values in the parameter value lists are the factory default values, and will be applied when factory default-restore is selected.

# AMX-1881 HD/SD 8 AES Embedder Guide to Installation and Operation

## USER PRESET menu

**LOAD:** Selects which predefined parameter settings will be used by loading a personalized profile.

**SAVE:** Saves the parameter settings in one of the five possible user preset profiles.

## INPUT SOURCE menu

**GROUP1, GROUP2, GROUP3, GROUP4:** Selects the source of audio for the four embedded audio groups. AES IN 1-2, AES IN 3-4, AES IN 5-6 & AES IN 7-8 select audio from the AMX-1881 inputs. PASS leaves the incoming embedded audio group intact, passing it through to the HD/SD-SDI output. DEL deletes the incoming embedded audio groups, leaving the HD/SD-SDI output without embedded audio. Sample rate converters permit the AES inputs to be synchronous or asynchronous.

*Note 1 (525 format only): In order to allow the presence of all four audio groups in the SD-SDI output, you must not activate RS-422 serial data in the ANC Signals Menu.*

*Note 2: The standard for embedded audio specifies 48kHz sampling, synchronous to video. Sample rate converters permit the input of asynchronous linear PCM audio, but AES signals containing non-PCM audio must be synchronous 48kHz. Asynchronous inputs will affect the integrity of channel status and user data, causing error flags to be set that may be detected by downstream equipment.*

## CONFIG AES menu

**AES IN 1, 2, 3, 4, 5, 6, 7, 8:** Select MUTE: ON or OFF, SWAP L&R: ON or OFF, or SAMPLE RATE CONV: OFF or AUTO for each of the eight AES channels. In AUTO mode, AES input detected as non-PCM audio will automatically turn off the sample rate conversion process.

**LEVEL:** Sets the audio gain from -96 dB to +12 dB in 0.5 dB steps.

**PHASE INVERT:** When "on", inverts the selected audio channel phase.

**DELAY:** sets the delay of the AES signal as it passes through the embedder, from NONE to 3 video frames in 0.5 frame steps.

**EMBED BITS:** Select the number of embedded bits in the AES signal to either 20 or 24 bits.

## CONFIG LTC menu

**EMBED:** Permits the user to embed LTC, as ATC into an HD-SDI signal or as DVITC into a SD-SDI signal.

**DELAY:** LTC delay selectable between NONE and a number of video frames (1 to 3).

**DVITC (only in video SD mode) :** LINE SELECT allows user to choose the position of DVITC in the video signal. DUPLICATE function allows the user to insert DVITC twice, on two different video lines. To insert DVITC twice, set DUPLICATE feature to ON.

## ANC SIGNALS menu

**RS-422:** The incoming RS-422 serial data may be embedded as ANC data. Select one of three modes:

- Select SERIAL to embed RS-422 in the horizontal interval (HANC), overwriting previously-embedded serial data
- Select METADATA to embed RS-422 in the vertical interval (VANC), overwriting previously-embedded metadata,
- Select OFF to leave RS-422 data untouched (no insertion)

*Note: In the 525 format, at least one of the four audio groups must be set to DELETE in the Input Source menu to allow RS-422 insertion.*

Only works with signals at 38.400 or 115.200 Bauds with accurate selection of BAUD RATE.

**SAMPLED GPI 1, 2:** The incoming GPI status data is sampled and may be embedded as ANC data. Select PASS to leave any already embedded GPI data untouched (no insertion) or OVERWRITE, which embeds incoming GPI data to the HD/SD-SDI signal while any existing embedded GPI data is removed (NB: select EMBED in the GPI Mode menu to enable this function).

## AUTO BLACK menu

Turn AUTO BLACK ON or OFF. Auto Black replaces the video input with a locally-generated video black in the event of an input failure, to maintain audio embedding.

## ASPECT RATIO menu

**AFD MODE:** Choose whether to PASS incoming AFD flags, BLANK them, or INSERT new flags in their place.

**AFD VALUE:** Select the AFD flag to insert if selected in AFD MODE. The available choices are format-dependent.

## GPI MODE menu

Select EMBED to embed GPI data in the ANC, or USER PRESET to use the GPI 1 and 2 inputs to select User Presets 1 and 2 in operation.

## TEST menu

**AES IN 1, 2, ..., 8:** User can enable (TONE) or disable (OFF) a test tone (1 KHz, R-steady, L-pulsed, at -18dBFS) on each of the eight AES channels individually.

**COLOR BAR:** User can enable (ON) or disable (OFF) color bars on the video output.

**TC LOOP:** User can enable a test loop (10 second loop starting at 23:59:00:00) that is inserted into the video as ATC (HD-SDI video) or DVITC (SD-SDI video).

## CONFIG ALARM menu

The user can configure the status LED presentation (ALARM LEVEL) and fault reporting (NONE or GPI) for some of the fault conditions of the AMX-1881. Those not listed in the menu are factory-set and cannot be user-modified.

# AMX-1881 HD/SD 8 AES Embedder Guide to Installation and Operation

## FACTORY DEFAULT menu

Select *RESTORE* to reset all of the menu-adjustable parameters to a factory-preset state (indicated in the menu by an underline in the list of available choices)

## iControl Interface

The AMX-1881 can be operated using Grass Valley's iControl system. This manual describes and explains the control panel associated with the AMX-1881. Please consult the iControl User's Guide for information about setting up and operating iControl.

In Control Navigator or iControl Websites, double-click on the AMX-1881 icon to open the control panel.

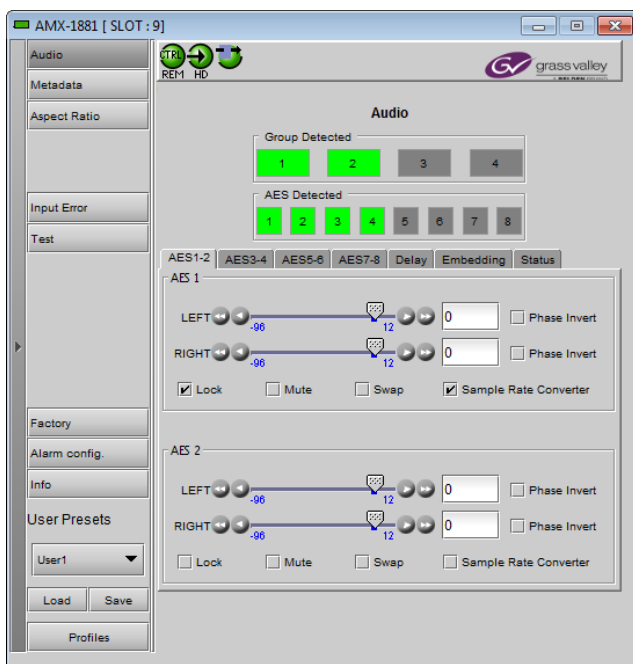

**Status Bar:** located at the top of the panel, it provides status icons for several key items and text messages explaining the detected errors. A complete description of the Status bar is given on this page.

Select the following control panels by clicking on their name at the left side of the panel:

**Audio:** provides controls for processing and embedding audio signals. A complete description of the Audio panel begins on this page.

**Metadata :** gives access to the controls for LTC, RS-422 and GPI status data embedding in an HD/SD SDI signal. A full description of the Metadata panel begins on page 10.

**Aspect Ratio:** gives access to control of Active Format Descriptor (AFD) and VLI data in the data stream. The panel is described beginning on page 10.

**Input Error:** allows the user to turn on and off the auto black feature. A complete description of the Input Error panel begins on page 12.

**Test:** gives the option to insert test signals. A complete description of the Test panel begins on page 12.

**Factory:** Allows the user to reset the options to the default factory-preset settings. A complete description of the Factory panel begins on page 12.

**Alarm Config:** Opens a new window where the on-board alarms of this AMX-1881 can be configured. See Annex 2 beginning on page 15 for a complete description.

**Info:** shows information about the AMX-1881 and allows entry of some data. A complete description of the Info panel begins on page 12.

**User Presets:** Allows the creation of user profiles for a personalised configuration of the AMX-1881. A complete description of the User presets begins on page 13.

**Profiles:** Opens a new window allowing the user to copy configuration data from this AMX-1881 to others accessible via iControl. See Annex 3 beginning on page 17 for details.

## Status bar

The **status bar** provides a continuous update of the status of the AMX-1881. The status bar includes three sections:

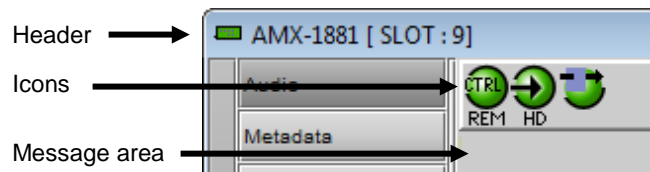

The **header** gives the product's name, and identifies the slot in which it is installed in its Densité frame. At the left is a status icon whose color shows the overall status of the AMX-1881 (see Annex 2 for more information):

- Green = OK
- Yellow = warning
- Red = error

The 3 **icons** monitor specific aspects of the AMX-1881's operations. Move the cursor over an icon to see its current status in the **message area** below the icons. If there is an error status, the message will appear automatically

The first icon shows whether the remote control of this AMX-1881 device is enabled or not.

The second icon shows the input status. Move the cursor over the icon to display the input signal format.

The third icon indicates if audio or video test signals are active.

## Audio

The **audio** tab shows the audio groups detected and provides resources for managing the audio processing of the AMX-1881.



# AMX-1881 HD/SD 8 AES Embedder Guide to Installation and Operation

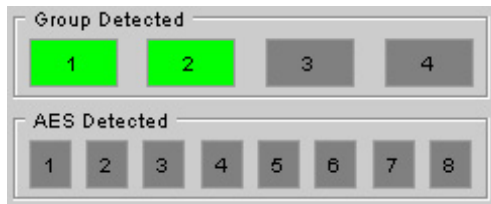

**Group detected:** indicates embedded audio groups in the AMX-1881 SDI input by turning green.

**AES detected:** indicates AES audio on the indicated AMX-1881 AES input by turning green.

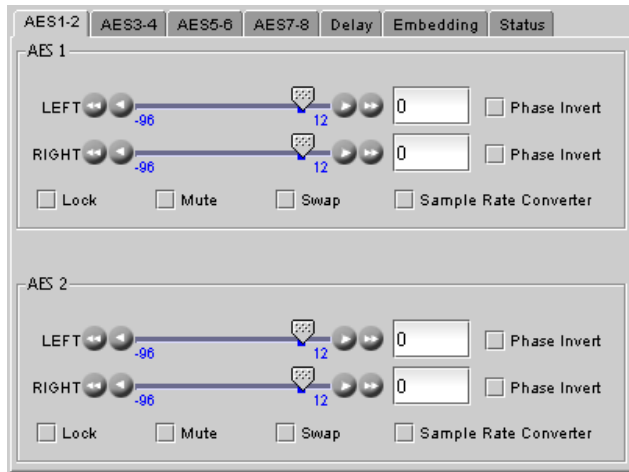

To configure the **AES** digital audio signals, access the AES1-2 through AES7-8 tabs. There are two sliders (left and right for stereo sound) available for each AES to set the level from -96 dB to +12 dB in steps of 0.5 dB. To invert the selected audio channel phase, check the **phase invert** boxes. The **lock** option locks both channel level sliders together, so that moving one slider moves the other one as well. The **mute** option mutes both audio channels completely. The **swap** option interchanges the right and the left audio channels. The **sample rate converter** can be set to either auto or off. While in auto mode, the sample rate conversion process is automatically turned off upon detection of non-pcm channel status.

The **Delay** tab allows the user to set the delay of the AES audio as it passes through the embedder. The delay is selectable between none, and a number of video frames (0 to 3 frames in 0.5 frames steps).

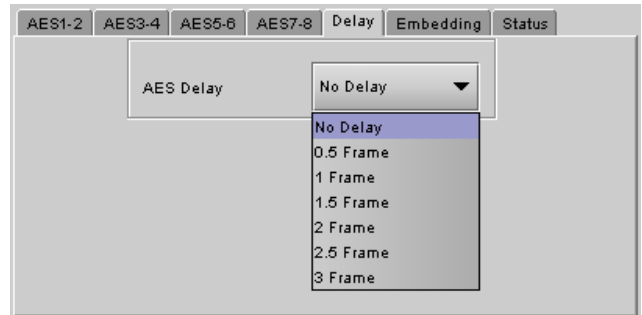

The **Embedding** tab specifies the content of the AES groups embedded in the output signal. Each group can be composed of a pair of AES inputs (AES1-2, AES3-4, AES5-6, or AES7-8). If the video input already contains an embedded audio group, it can either be allowed to pass through directly without modifications (PASS) or it can be deleted (DELETE). The **SD Embed bits** is fixed at 24 bits for HD. For SD signals, the options are 20 or 24 bits

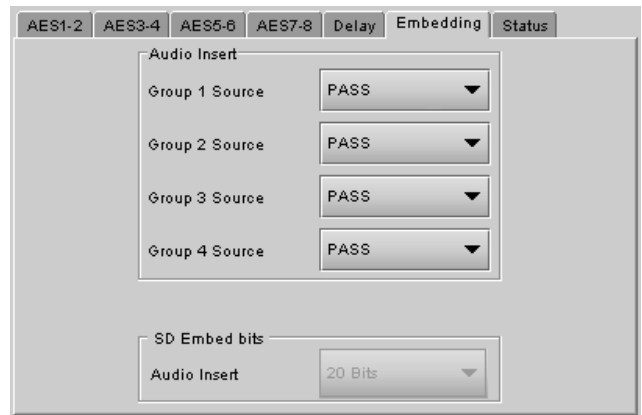

The **status** tab monitors some of the information carried in the AES inputs channel status..

AES In	Bits	Mode	Emph	Use	Encd
AES 1	N/I	N/I	N/I	PRO	PCM
AES 2	N/I	N/I	N/I	PRO	PCM
AES 3	N/I	N/I	N/I	PRO	PCM
AES 4	N/I	N/I	N/I	PRO	PCM
AES 5	N/I	N/I	N/I	PRO	PCM
AES 6	N/I	N/I	N/I	PRO	PCM
AES 7	N/I	N/I	N/I	PRO	PCM
AES 8	N/I	N/I	N/I	PRO	PCM

The **Bits** status monitors the audio samples word length (in bits). The possible values are 16 bits, 20 bits, 24 bits or other. If the information is not available, it will show as N/I.

The **Mode** status monitors the channel mode. The possible values are two channels (Two ch), one channel (One ch), primary or secondary (Pri/Sec), Stereo or Other. If not indicated, it will show as N/I.

# AMX-1881 HD/SD 8 AES Embedder

## Guide to Installation and Operation

The **Emph** status monitors the audio channel emphasis. The possible values are none, 50/15  $\mu$ s (CD type) and J.17. If not indicated, it will show as N/I.

The **Use** status monitors the use of channel status block. The possible values are either professional (PRO) or consumer (CONS).

The **Encd** status monitors the audio channel encoding type. The possible values are PCM or NPCM (non PCM).

### Metadata

The **Metadata** tab offers setting options for 3 types of input signals: LTC, RS422 and GPI.

The **LTC** tab allows the embedding of an LTC signal as ATC into an HD-SDI or as DVITC into an SD-SDI signal.

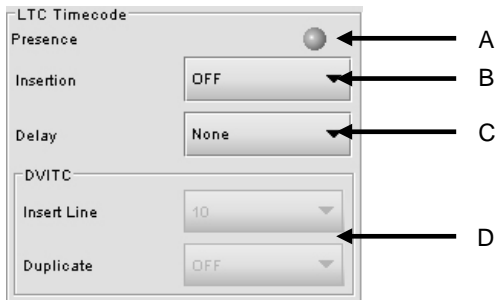

**A:** the **presence** icon shows if an LTC signal is detected by turning green.

**B:** the **insertion** can be toggled to OFF or ON, to disable or activate the embedding of the LTC signal into the HD/SD SDI signal. When insertion is ON, the existing time code is overwritten.

ATC packets are inserted as follows:

- 1080i – ATC-VITC: lines 9/571; ATC-LTC: line 10
- 720p – ATC-VITC: line 9; ATC-LTC: line 10

**C:** the **delay** option allows correction of lipsync problems by adding up to 3 frames of delay.

**D:** the DVITC menu has two parameters, **insert line** and **duplicate**. The insert line option allows the user to choose the position of the DVITC in the video signal, while the duplicate option inserts a second DVITC packet on the video line following the one chosen by the user.

The **RS-422** tab allows the embedding of RS-422 serial data as ANC data in the HS/SD SDI signal.

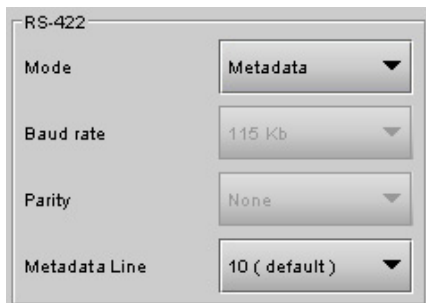

Mode:

**OFF** will leave any embedded RS-422 data untouched, **SERIAL:** (HD and SD): embeds the RS-422 data in the horizontal blanking (HANC), overwriting previously-embedded serial data. The **Baud Rate** and **Parity** pull-downs are activated:

- Baud Rate: supports 38.4 and 115 Kb
- Parity: none, even or odd

*Note: in 525 format, to activate the Serial mode, at least one of the four audio groups must be set to "Delete"*

**METADATA** (HD only): embeds the RS-422 data in the vertical interval (VANC).

- The **Metadata Line** pull-down becomes active, allowing selection of the line to write the data (9-20)
- Data in the selected line is overwritten
- Data in other lines is unchanged.

The **GPI** tab gives access to two different functions, selected by the **Mode** pull-down:

**User Preset:** the two GPI inputs are used to select User Presets 1 and 2 (see User Presets on page 14)



**Embed:** allows the embedding of sampled GPI status data as ANC data. Select either Pass (leaving the already embedded data untouched) or Overwrite (embedding the new GPI data in the HD/SD-SDI signal, overwriting the previous data) for each of the two GPI data sets.



### Aspect Ratio

The Active Format Descriptor (AFD) conveys information about the "protected" area inside a picture, the aspect ratio, and the preferred presentation of the image. The AFD consists of the Aspect Ratio of the display monitor for which the signal is intended, and a code indicating the nature of the protected area and preferred display.

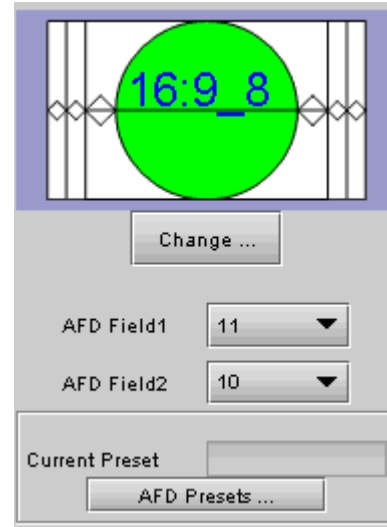
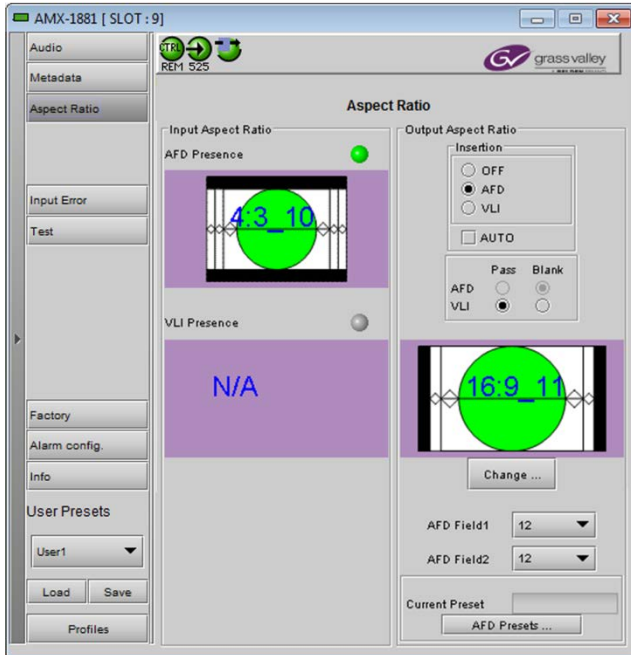

The INSERT and AUTO modes require the user to select a flag to insert. The graphic shows the code for the current selection, while the **Change** button opens a window showing all available flags.

The **Input aspect ratio** section indicates the presence of AFD and VLI flags in the incoming video via status icons (green if flags are present; gray otherwise), and displays an interpretive graphic that incorporates the flag code.

The **Output Aspect Ratio** section provides controls for insertion of aspect ratio signalling in the output data stream.

Use the radio buttons in the **Insertion** box to select AFD, VLI or OFF as the insertion mode.

- Incoming aspect ratio data of the selected type will be deleted, and replaced by a specified flag, designated at the bottom of the panel.
- If the AUTO box is checked, the AMX-1881 will pass any incoming flags of the selected type unchanged, but when no flag is detected on the input, it will insert a specified flag into the output data stream.

Any incoming aspect ratio signalling data that is *not selected* for overwriting via the Insertion controls may be either blanked or passed, using the radio buttons shown:

- PASS: pass any incoming flags unchanged
- BLANK: delete any incoming flags



Incoming data that is selected for overwriting via insertion will be gray – e.g. AFD in the figure.

- INSERT: insert an AFD flag in the output, overwriting any incoming flags
- AUTO: Pass any incoming flags unchanged, but when no flag is detected on the input, insert a specified flag into the output data stream.

# AMX-1881 HD/SD 8 AES Embedder Guide to Installation and Operation

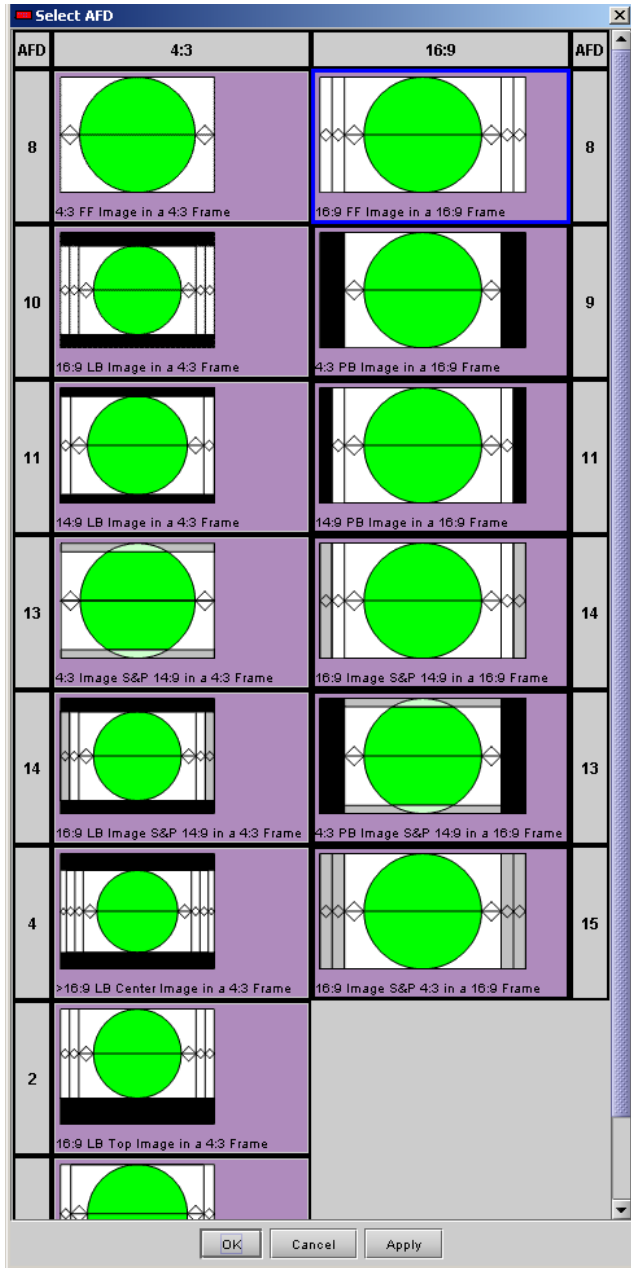

Scroll down if necessary to see all possible flag options. Click on one to select it, and click *Apply* at the bottom of the window to confirm the selection.

Use the **AFD Field 1** and **AFD Field 2** pull-downs to select the line on which AFD information will be inserted on the two fields.

*NOTE: If incoming flags are found on a line after the selected insertion line, the AMX-1881 will not be able to change its insertion decision in the AUTO mode until the next field/frame, and will therefore not be field/frame accurate.*

The **AFD presets** button allows the user to save commonly-used selections under descriptive names, making it easy to recall and load selections for specific situations. The name of the current preset is displayed.

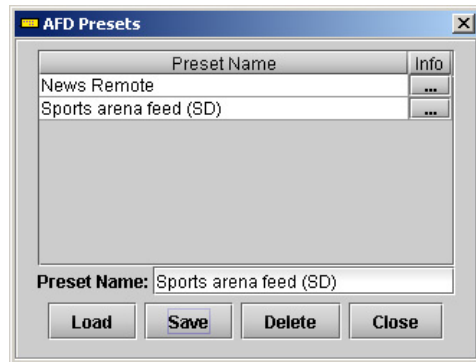

- Type a name in the Preset Name box and click *Save* to save the current Mode and Aspect Ratio settings under this name. The newly-saved layout is also loaded (see below) when the save command is selected, so its name will be shown in the *Current Preset* box beside the AFD Presets button in the Output AFD window.
- Click a name in the list to select it, and then click *Load* to configure the AMX-1881 to send that AFD flag.

To see the mode and value saved in any Preset, click the Info button to the right of its name to open the *Parameters* window:

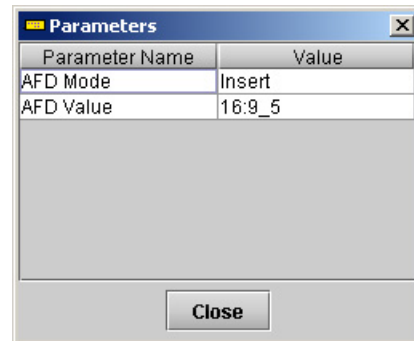

## Input error

In the event of an input failure, activating the **auto black** feature will replace the video input with a locally generated video black in order to maintain audio embedding.

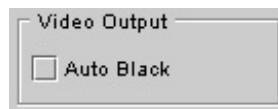

## Test

The **test** menu allows the user to enable test signals on the AES and video outputs for troubleshooting purposes.

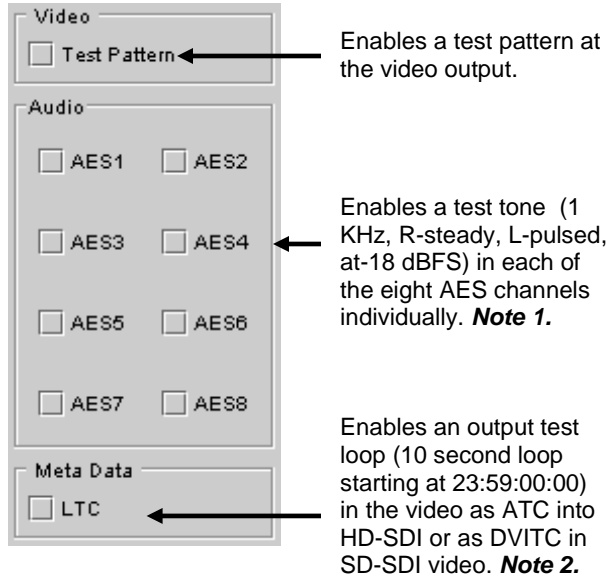

## Notes:

1. If an AES checkbox is enabled, the corresponding AES channel should be used as a source for embedding in an audio group. Set this in the *Audio Insert* section of the *Audio* panel's *Embedding* tab. (See page 9)
2. LTC timecode insertion should be set to *ON* in the Metadata / LTC panel in order for the timecode to be embedded. (See page 10)

## Factory

Clicking the **Load Factory** button will restore all of the adjustable parameters to a factory-preset state. Those preset settings are indicated by an underline in the **AMX-1881 menu** on pages 4 to 6 of this manual.

## Alarm Config

See Annex 2 on page 15 for details.

## Info

The **Info** tab provides information about the AMX-1881, and provides some data entry options.

**Label and Short label:** type a label and a short label for this device in the appropriate data entry boxes.

**Source ID:** enter the source ID

The **details** button gives additional information about the device. The manufacturing process, firmware version, service version and panel version can be found here.

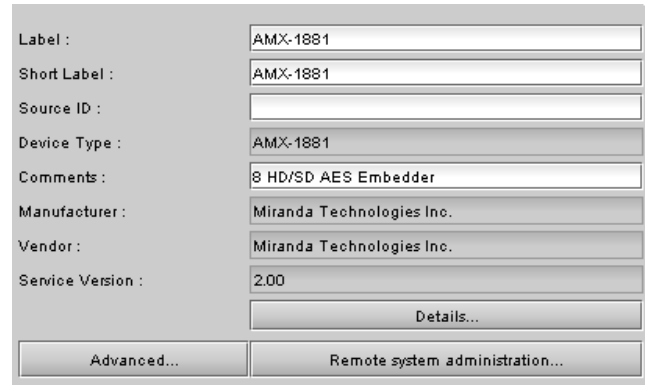

The **advanced** button shows the long ID of the device. The Long ID is the address of this AMX-1881 in the iControl network.

Click the **remote system administration** button to open the "joining locators: AMX-1881" window, which lists remote lookup services to which this AMX-1881 is registered, and allows new ones to be added.

## User presets

The AMX-1881 has memory registers which can hold up to 5 user-defined parameter settings



**Select** any one of the five presets using the pull-down list. The name of the currently-selected User Preset is shown on the name bar.

- Click **Load** to load the contents of the selected User Preset into the AMX-1881. All parameter settings and values will be replaced by the contents of the selected User Preset.
- Click **Save** to store the current parameter settings and values from the AMX-1881 into the selected User Preset. The existing contents of the preset will be overwritten.

Note that you can use GPI inputs 1 and 2 to select and load Presets 1 and 2 if you have chosen the *User Preset* mode in the GPI tab in the Metadata window.

## Profiles

See Annex 3 on page 17 for details.

# AMX-1881 HD/SD 8 AES Embedder

## Guide to Installation and Operation

### ANNEX 1 – Connecting Cable Specification

This cable joins the AMX-1881 rear panel to the AMX-1881 breakout panel

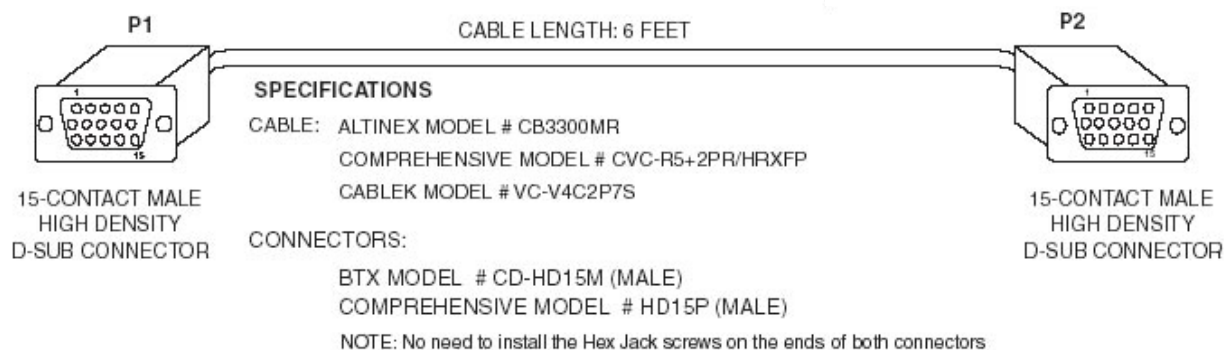

WIRE CHART					
P1	P2	ALTINEX CABLE	COMPREHENSIVE CABLE	CABLEK CABLE	SIGNAL
PIN1	PIN1	RED COAX (SIGNAL)	RED COAX (SIGNAL)	RED COAX (SIGNAL)	AES5
PIN2	PIN2	GREEN COAX (SIGNAL)	GREEN COAX (SIGNAL)	GREEN COAX (SIGNAL)	AES6
PIN3	PIN3	BLUE COAX (SIGNAL)	BLUE COAX (SIGNAL)	BLUE COAX (SIGNAL)	AES7
PIN4	PIN4	N/C	N/C	N/C	N/C
PIN5	PIN5	TWST PAIR 2 (BLACK) and TWST PAIR 2 (SHIELD)	TWST PAIR 2 (BLACK) and TWST PAIR 2 (SHIELD)	TWISTED PAIR 1 (WHITE)	DIG GROUND
PIN5	PIN5	GRAY COAX (SHIELD)	YELLOW COAX (SHIELD)		
PIN6	PIN6	RED COAX (SHIELD)	RED COAX (SHIELD)	RED COAX (SHIELD)	ANALOG GROUND
PIN7	PIN7	GREEN COAX (SHIELD)	GREEN COAX (SHIELD)	GREEN COAX (SHIELD)	ANALOG GROUND
PIN8	PIN8	BLUE COAX (SHIELD)	BLUE COAX (SHIELD)	BLUE COAX (SHIELD)	ANALOG GROUND
PIN9	PIN9	NO PIN INSTALLED	NO PIN INSTALLED	NO PIN INSTALLED	NO PIN
PIN10	PIN10	BLACK COAX (SHIELD)	BLACK COAX (SHIELD)	YELLOW COAX (SHIELD)	DIG GROUND
PIN11	PIN11	TWST PAIR 1 (BLACK) and TWST PAIR 1 (SHIELD)	TWST PAIR 1 (BLACK) and TWST PAIR 1 (SHIELD)	TWISTED PAIR 2 (WHITE)	GPI-COM
PIN12	PIN12	TWISTED PAIR 1 (RED)	TWISTED PAIR 1 (RED)	TWISTED PAIR 2 (RED)	GPI-1
PIN13	PIN13	BLACK COAX (SIGNAL)	BLACK COAX (SIGNAL)	YELLOW COAX (SIGNAL)	ASE8
PIN14	PIN14	GRAY COAX (SIGNAL)	YELLOW COAX (SIGNAL)	TWISTED PAIR 1 (RED)	LTC
PIN15	PIN15	TWISTED PAIR 2 (WHITE)	TWISTED PAIR 2 (RED)	ORANGE 24AWG (Tin copper wire)	GPI-2

## ANNEX 2 – Alarm Configuration

Click on the *Alarm Config* button on the left-hand side of the iControl panel to open this panel in new window.

This panel allows the alarm reporting of the AMX-1881 to be configured.

The panel is organized in columns.

### Status/Name









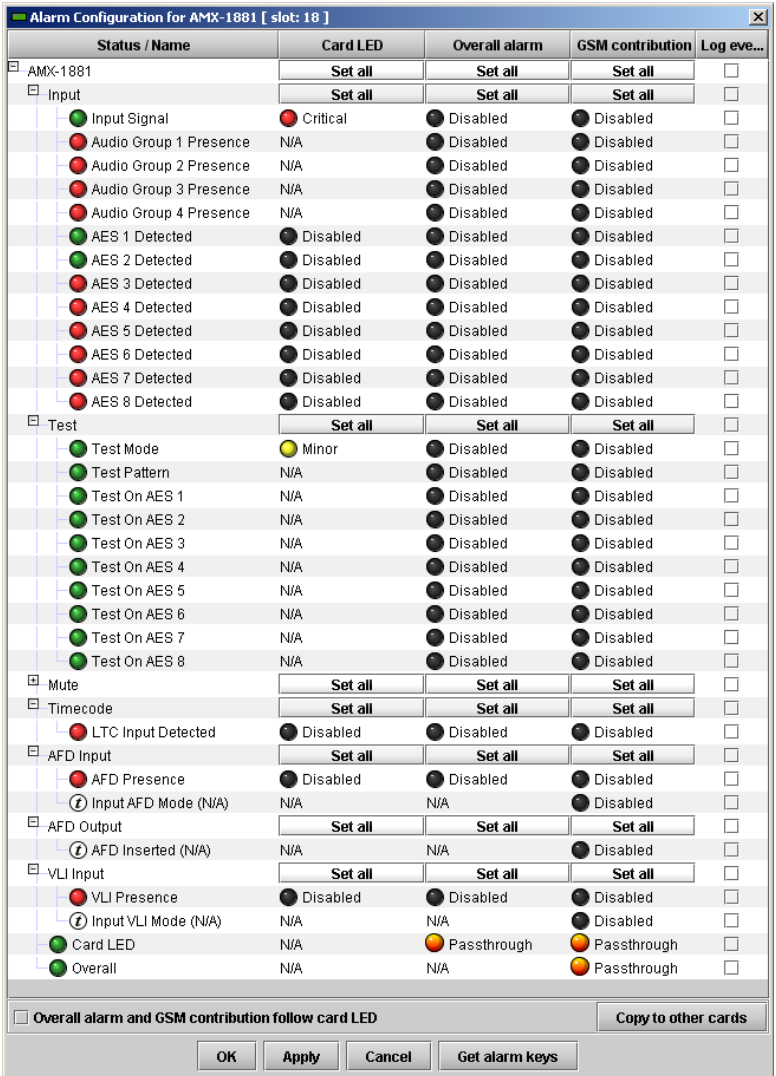





























































This contains an expandable tree listing all the alarms reported by this AMX-1881 card.

- Each alarm name includes an icon that shows its current status
- Some alarms may be text-only and the alarm status is shown in the name and not by a status icon,

e.g.  Input AFD Mode (N/A)

The **Overall alarm** and **GSM contribution** columns contain pulldown lists that allow the level of contribution of each individual alarm to the alarm named in the column heading to be set.







Status / Name	Card LED	Overall alarm	GSM contribution	Log eve...
AMX-1881	Set all	Set all	Set all	<input type="checkbox"/>
Input	Set all	Set all	Set all	<input type="checkbox"/>
Input Signal	 Critical	 Disabled	 Disabled	<input type="checkbox"/>
Audio Group 1 Presence	N/A	 Disabled	 Disabled	<input type="checkbox"/>
Audio Group 2 Presence	N/A	 Disabled	 Disabled	<input type="checkbox"/>
Audio Group 3 Presence	N/A	 Disabled	 Disabled	<input type="checkbox"/>
Audio Group 4 Presence	N/A	 Disabled	 Disabled	<input type="checkbox"/>
AES 1 Detected	 Disabled	 Disabled	 Disabled	<input type="checkbox"/>
AES 2 Detected	 Disabled	 Disabled	 Disabled	<input type="checkbox"/>
AES 3 Detected	 Disabled	 Disabled	 Disabled	<input type="checkbox"/>
AES 4 Detected	 Disabled	 Disabled	 Disabled	<input type="checkbox"/>
AES 5 Detected	 Disabled	 Disabled	 Disabled	<input type="checkbox"/>
AES 6 Detected	 Disabled	 Disabled	 Disabled	<input type="checkbox"/>
AES 7 Detected	 Disabled	 Disabled	 Disabled	<input type="checkbox"/>
AES 8 Detected	 Disabled	 Disabled	 Disabled	<input type="checkbox"/>
Test	Set all	Set all	Set all	<input type="checkbox"/>
Test Mode	 Minor	 Disabled	 Disabled	<input type="checkbox"/>
Test Pattern	N/A	 Disabled	 Disabled	<input type="checkbox"/>
Test On AES 1	N/A	 Disabled	 Disabled	<input type="checkbox"/>
Test On AES 2	N/A	 Disabled	 Disabled	<input type="checkbox"/>
Test On AES 3	N/A	 Disabled	 Disabled	<input type="checkbox"/>
Test On AES 4	N/A	 Disabled	 Disabled	<input type="checkbox"/>
Test On AES 5	N/A	 Disabled	 Disabled	<input type="checkbox"/>
Test On AES 6	N/A	 Disabled	 Disabled	<input type="checkbox"/>
Test On AES 7	N/A	 Disabled	 Disabled	<input type="checkbox"/>
Test On AES 8	N/A	 Disabled	 Disabled	<input type="checkbox"/>
Mute	Set all	Set all	Set all	<input type="checkbox"/>
Timecode	Set all	Set all	Set all	<input type="checkbox"/>
LTC Input Detected	 Disabled	 Disabled	 Disabled	<input type="checkbox"/>
AFD Input	Set all	Set all	Set all	<input type="checkbox"/>
AFD Presence	 Disabled	 Disabled	 Disabled	<input type="checkbox"/>
Input AFD Mode (N/A)	N/A	N/A	 Disabled	<input type="checkbox"/>
AFD Output	Set all	Set all	Set all	<input type="checkbox"/>
AFD Inserted (N/A)	N/A	N/A	 Disabled	<input type="checkbox"/>
VLI Input	Set all	Set all	Set all	<input type="checkbox"/>
VLI Presence	 Disabled	 Disabled	 Disabled	<input type="checkbox"/>
Input VLI Mode (N/A)	N/A	N/A	 Disabled	<input type="checkbox"/>
Card LED	N/A	 Passthrough	 Passthrough	<input type="checkbox"/>
Overall	N/A	N/A	 Passthrough	<input type="checkbox"/>

Overall alarm and GSM contribution follow card LED Copy to other cards

OK Apply Cancel Get alarm keys

### Levels associated with these alarms

The pulldown lists may contain some or all of the following options:

-  Disabled The alarm makes no contribution (black)
-  Minor The alarm is of minor importance (yellow)
-  Major The alarm is of major importance (orange)
-  Critical The alarm is of critical importance (red)
-  Passthrough The alarm exists but has no effect (used for text and composite alarms)

**Shortcut:** if you click **Set All** in one of the columns beside a major heading in the Status/Name column, you will open a pulldown that lets you assign a level to all alarms in that section of the column simultaneously.

- **Overall Alarm**

This column allows configuration of the contribution of each individual alarm to the Overall Alarm associated with this card. The Overall Alarm is shown in the upper left corner of the iControl panel, and also appears at the bottom of the Status/Name column.

- **GSM Contribution**

# AMX-1881 HD/SD 8 AES Embedder

## Guide to Installation and Operation

This column allows configuration of the contribution of each individual alarm to the GSM Alarm Status associated with this card. GSM is a dynamic register of all iControl system alarms, and is also an alarm provider for external applications. The possible values for this contribution are related to the Overall alarm contribution:

- If the Overall alarm contribution is selected as Disabled, the GSM alarm contribution can be set to any available value
- If the Overall alarm contribution is selected as any level other than disabled, the GSM contribution is forced to follow the Overall Alarm.

### Log Events

iControl maintains a log of alarm events associated with the card. The log is useful for troubleshooting and identifying event sequences. Click in the checkbox to enable logging of alarm events for each individual alarm.

At the bottom of the window are several other controls:

### Overall Alarm and GSM Contribution follow card LED

Click in the checkbox to force the Overall alarm and GSM contribution to be identical to the Card LED status

- All Overall alarms and GSM contributions for which there is a Card LED alarm will be forced to match the Card LED alarm
- All Overall Alarms and GSM contributions for which there is no Card LED alarm will be forced to Disabled

A warning box will open allowing you to confirm the action, since it will result in changes to the configuration and there is no *undo* function.

### Copy to other cards

Click this button to open a panel that allows the alarm configuration set for this card to be copied into another AMX-1881 card.

- Select one or more destination cards from the list in the window by clicking in the checkboxes, or all of them by clicking in the *All* checkbox
- Note that when you do a Copy Profile for this card (see Annex 3), the alarm configuration is copied along with all the other settings.

### Get alarm keys

Click this button to open a save dialog where you can save a file containing a list of all alarms on this card and their current values, along with an Alarm Key for each. The alarm keys are useful for system integration and troubleshooting.

- The file is saved in Excel.csv format

### OK, Apply, Cancel

- **OK** accepts the settings and closes the window once the card confirms that there are no errors.
- **Apply** accepts the settings, but leaves the window open
- **Cancel** closes the window without applying any changes, and leaves the previous settings intact

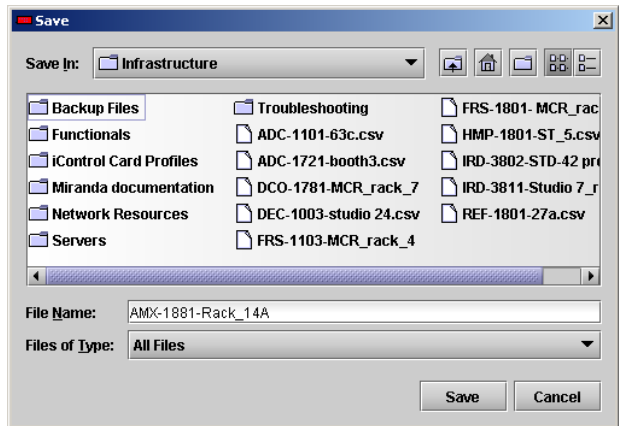
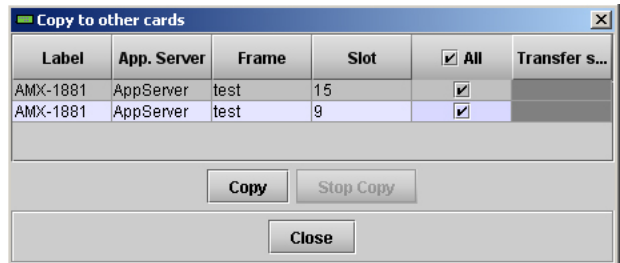
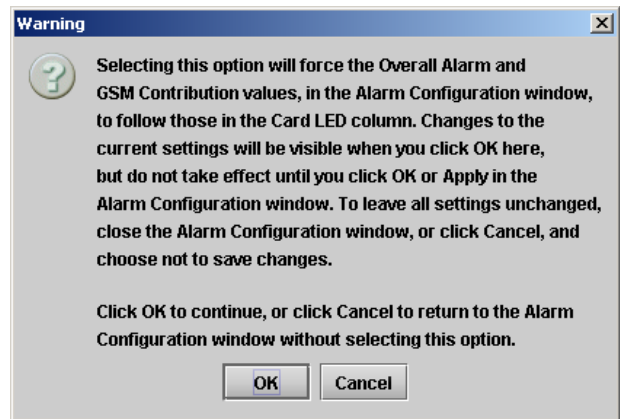



### Annex 3 – Profile Copy

This panel provides the option to save and recover the entire card configuration (including user presets if desired) on an external disk, or to copy it to another AMX-1881 card.

Click on *Profiles* to open the Profile Copy window.

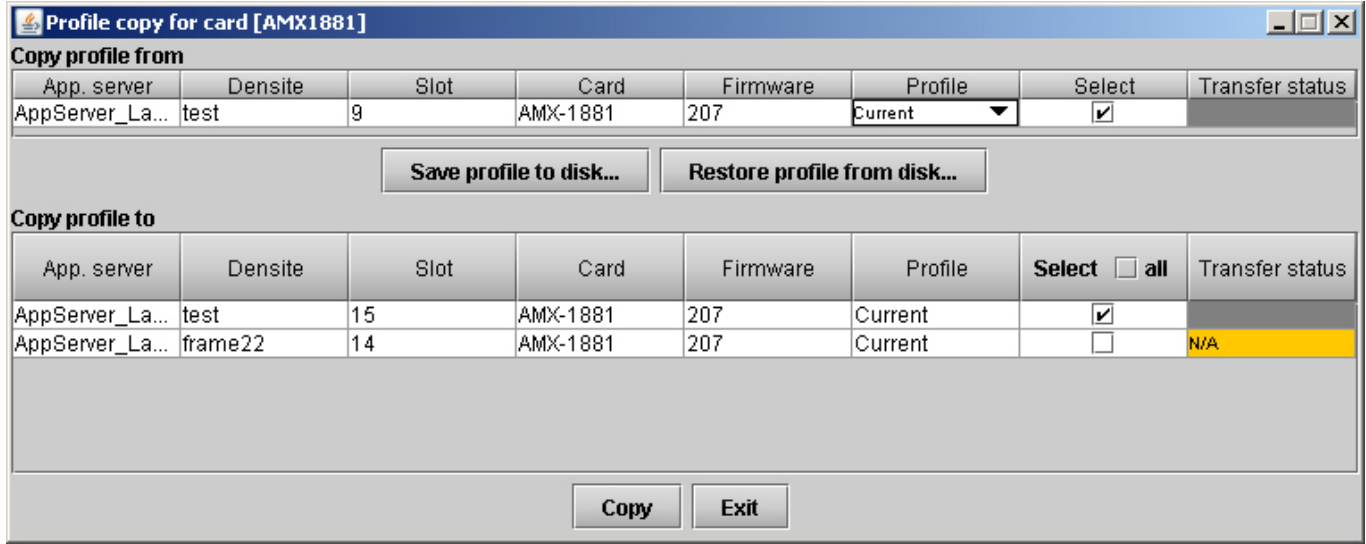

#### Copy Profile From:

This line shows this AMX-1881 card, and identifies it by App server, Densité frame and slot number, card type and firmware version.

The *Profile* column has a pulldown that allows you to select which profiles you will work with, and gives these choices:

- Current, User1, User2, User3, User4, User5

The *Select* column includes a checkbox, preselected as checked, to confirm that you want to work with the current card.

#### Save Profile to Disk...

Click this button to open a Save dialog allowing you to specify a file name and location to which the selected profiles for this card will be saved.

*Hint - It is a good idea to create a folder for these files, because they are not explicitly identified as AMX-1881 profiles, and will be difficult to find and identify if not clearly named and conveniently located.*

- Click the save button once the name and location have been identified in the Save box
- If the file is saved correctly, the Transfer Status box on the right of the *Copy profile from* line will indicate *Succeeded* against a green background
- If the file was not saved for some reason, the Transfer Status box to the right of the *Copy profile from* line will indicate *Failed* against a red background

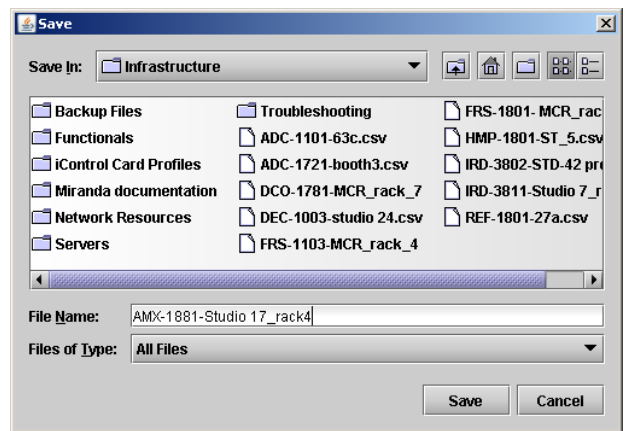

# AMX-1881 HD/SD 8 AES Embedder

## Guide to Installation and Operation

### Restore profile from disk...

Click this button to open an *Open* dialog box within which you can locate and select a valid AMX-1881 profile file.

- Click Open to read the contents of the file and to reconfigure this AMX-1881's profiles according to its contents
- While the reconfiguration is in progress, the Transfer Status box on the right of the *Copy profile from* line will indicate *Working* against a yellow background
- When the reconfiguration is complete, the Transfer Status box on the right of the *Copy profile from* line will indicate *Succeeded* against a green background

**Note:** There is no need to select a profile using the Profile pulldown (e.g. current, User1, etc.) when restoring a profile from disk, because the profile selection is stored within the file.

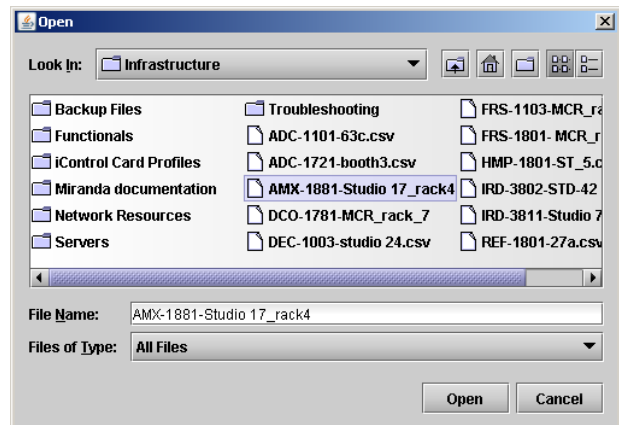

### Copy profile to section

This line shows other AMX-1881 cards that are available on the iControl network, each identified by App server, Densité frame and slot number, card type and firmware version.

The *Profile* column shows the same information as is shown for the current card in the *Copy profile from* line, i.e.

- Current, User1, User2, User3, User4, User5

The *Select* column includes a checkbox to identify which AMX-1881 cards you wish to copy profiles into from the current card.

- For convenience, a *Select all* checkbox is provided in the column header
- Source and destination cards must have the same firmware version for the copy profile to work

Click *Copy* to copy the selected profiles from this card into the selected other AMX-1881 cards

- While the profile copy operation is in progress, the Transfer Status box on the right of the *Copy profile to* line will indicate *Working* against a yellow background
- When the profile copy operation is complete, the Transfer Status box on the right of the *Copy profile to* line will indicate *Succeeded* against a green background

## Electromagnetic Compatibility

**FC** This equipment has been tested for verification of compliance with FCC Part 15, Subpart B requirements for Class A digital devices.

---

**NOTE:** This equipment has been tested and found to comply with the limits for a Class A digital device, pursuant to part 15 of the FCC Rules. These limits are designed to provide reasonable protection against harmful interference when the equipment is operated in a commercial environment. This equipment generates, uses, and can radiate radio frequency energy and, if not installed and used in accordance with the instruction manual, may cause harmful interference to radio communications. Operation of this equipment in a residential area is likely to cause harmful interference in which case the user will be required to correct the interference at his own expense.

---

**CE** This equipment has been tested and found to comply with the requirements of the EMC directive 2004/108/CE:

- EN 55022 Class A radiated and conducted emissions
- ENV 50204
- EN 61000-3-2 Harmonic current injection
- EN 61000-3-3 Limitation of voltage changes, voltage fluctuations and flicker
- EN 61000-4-2 Electrostatic discharge immunity
- EN 61000-4-3 Radiated electromagnetic field immunity – radio frequencies
- EN 61000-4-4 Electrical fast transient immunity
- EN 61000-4-5 Surge immunity
- EN 61000-4-6 Conducted emissions immunity
- EN 61000-4-11 Voltage dips, short interruptions and voltage variations immunity

### How to contact us:

For technical assistance, please contact the Grass Valley Technical support centre nearest you:

#### Americas

*Telephone:*

+1-800-224-7882

*e-mail:*

techsupp@miranda.com

#### Asia

*Telephone:*

+852-2539-6987

*e-mail:*

asiatech@miranda.com

#### Europe, Middle East, Africa, UK

*Telephone:*

+44 (0) 1491 820222

*e-mail:*

eurotech@miranda.com

#### China

*Telephone:*

+86-10-5873-1814

*e-mail:*

asiatech@miranda.com

#### France (only)

*Telephone:*

+33 (0) 1 55 86 87 88

*e-mail:*

eurotech@miranda.com

Visit our web site at [www.grassvalley.com](http://www.grassvalley.com)