

CameraMan

3-CCD DIGITAL ROBOTIC CAMERA SYSTEM

Installation and Operation Manual

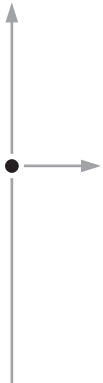

L1207100 Rev A
2000

the most watched worldwide

Contacting Grass Valley

Region	Voice	Fax	Address	Web Site
North America	(800) 547-8949 Support: 530-478-4148	Sales: (530) 478-3347 Support: (530) 478-3181	Grass Valley P.O. Box 599000 Nevada City, CA 95959-7900 USA	www.thomsongrassvalley.com
Pacific Operations	+852-2585-6688 Support: 852-2585-6579	+852-2802-2996		
U.K., Asia, Middle East	+44 1753 218 777	+44 1753 218 757		
France	+33 1 45 29 73 00			
Germany, Europe	+49 6150 104 782	+49 6150 104 223		

Copyright © Grass Valley. All rights reserved.

Grass Valley Web Site

The www.thomsongrassvalley.com web site offers the following:

Online User Documentation — Current versions of product catalogs, brochures, data sheets, ordering guides, planning guides, manuals, and release notes in .pdf format can be downloaded.

FAQ Database — Solutions to problems and troubleshooting efforts can be found by searching our Frequently Asked Questions (FAQ) database.

Software Downloads — Software updates, drivers, and patches can be downloaded.

Table Of Contents

I. CameraMan 3-CCD DIGITAL Camera Overview	
▼ About this Manual	1
▼ 3-CCD Product Description	2-3
▼ 3-CCD DIGITAL Camera Components	4
▼ CameraMan Ports and Jacks	5
▼ CameraMan LED Displays	6
▼ CameraMan Configuration Switches	7
II. Connecting the CameraMan 3-CCD DIGITAL Camera	
▼ Mounting the CameraMan 3-CCD DIGITAL Camera	8
▼ Connecting to the Camera System	
Connecting the Camera Control Cables	9
Connecting the SDI Video Output.....	9
Connecting to the RS-232 Port	10
▼ Connecting Camera Control Devices	11
▼ Cable Restraint and System Power	
Restraining the Cable Connections	12
Connecting the Power Supply	12
III. Configuring the CameraMan 3-CCD DIGITAL Camera	
▼ Switch Configuration	13
IV. Use Your CameraMan	
▼ System Startup	14
V. Appendices	
▼ A: Troubleshooting	15
▼ B: Multiple Camera Applications	16
▼ C: Camera Specifications	17
▼ D: Pin-out Diagrams	18
▼ E: Field-of -View Specifications	19-20
▼ F: The 18x Lens Shroud	21
▼ G: Typical System Diagram	22
▼ H: On-screen Camera Menus	23-29

About this Manual

The CameraMan 3-CCD DIGITAL Camera is unmatched in quality, flexibility and expandability, providing one of the best video-communications cameras in the industry.

This manual will introduce the CameraMan 3-CCD DIGITAL Camera, explain how to install, connect and configure it, and how to use it in single and multi-camera network applications. In addition, useful diagrams and charts can be found in the appendices, providing technical specifications.

Two icons are used throughout the manual:



This icon alerts *important instructions* in the operation and maintenance of the CameraMan 3-CCD DIGITAL Camera.



This icon alerts *tips or noteworthy suggestions* in the operation or maintenance of the CameraMan 3-CCD DIGITAL Camera.

The 3-CCD DIGITAL Camera should include these components:

- One CameraMan 3-CCD DIGITAL Camera (with 18x lens and Mini Docking Station attached)
- One CameraMan Power Supply.
- One RS-485 Connector "T"
- One 3' CameraMan Communication Cable
- One 25' CameraMan Keypad Cable
- One 3-CCD Installation and Operations Manual

3-CCD Product Description

The 3-CCD DIGITAL Camera is designed to be used in a variety of applications. This camera may have been purchased with one of the below packages. Information on upgrade paths, and recommended accessories can be found on this page.

Product Description

The 3-CCD DIGITAL Camera's pan/tilt functions, zoom perspective, focus and IMAGE settings can be controlled via the Remote Control Keypad, PVTV DIGITAL SHOT Director, or Tracking Keypad. In addition to the camera-control these optional accessories provide, they also provide multi-camera control and store up to 125 presets per camera.

Student Camera Upgrade Package

Used in distance learning applications, this system gives each student the power to be instantly identified by the camera with the touch of a press to talk microphone. This includes the Programmable Response Module for distributed preset control and a 3-CCD Camera Control Keypad.

Presenter Camera Upgrade Package

Used in distance learning, telemedicine and videoconferencing applications. The system gives presenters and instructors the ability to provide dynamic presentations while the camera automatically follows their every move. Includes a Tracking Ring Package, 3-CCD RF Tracking Keypad, and Main Docking Station.

Personal Locator Upgrade Package

For videoconferencing applications, this system gives each videoconferencing participant the power to be instantly identified by the camera with the touch of a MY TURN button on individually controlled keypads. Includes three 3-CCD RF Personal Locator Keypads and one RF Chairperson Locator Keypad for distributed preset control.

Deluxe Upgrade Package

Combines the distributed preset control of the Personal Locator System and the autoTRACK presentation capabilities of the Presenter Camera System. Includes three 3-CCD RF Personal Locator Keypads, one RF Chairperson Locator Keypad, Tracking Ring Package, 3-CCD RF Tracking Keypad, and Main Docking Station.

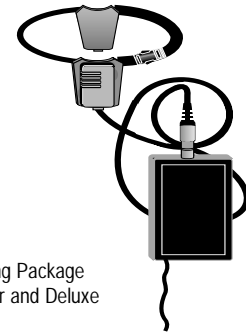

Tracking Ring Package
for Presenter and Deluxe
Systems

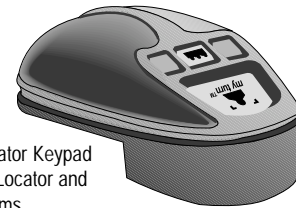

Personal Locator Keypad
for Personal Locator and
Deluxe Systems

3-CCD Product Description

Recommended Accessories

Camera Control Keypad

Whether used in wireless RF, or hard-wired mode, this keypad gives the ability to control the pan, tilt, zoom, focus, iris, and location presets for up to three separate cameras. The keypad comes standard with the Student Camera System, and the Tracking Keypad comes standard with the Presenter and Deluxe Camera Systems.

PVTV DIGITAL SHOT Director

Some applications require precise and flexible camera control. The DIGITAL SHOT Director is a joystick controller designed to give ultimate control by affording the ability to adjust to the pan, tilt, zoom, focus, iris, CCU functions and location presets on 1 to 16 different cameras from one location. And its built-in CCU functionality allows adjustment of each camera's on-screen image.

CameraMan Tally Light

For visual indication of which camera is selected in a multi-camera application, the CameraMan Tally Light provides a high intensity indication from an easy-to-install interface on the rear of the camera. A bright red indicator is mounted to the top of a flexible pedestal, allowing precise adjustment and positioning of the light for the best possible studio-wide observation. Control of the Tally light can be accomplished through Control Center, and PVTV STUDIO, as well as via an external closure connected to a side-mounted Phoenix connector. All current 3-CCD cameras are Tally-light compatible, and previous models are factory upgradeable.

PVTV SCRIPT Viewer Display

Adding a full-feature teleprompting display that moves with the camera is now available with the addition of the powerful PVTV SCRIPT Viewer system. The 12" active matrix, full color displays are available separately and are easily mounted to the camera. Contact your reseller for more information on the complete Script Viewer system.

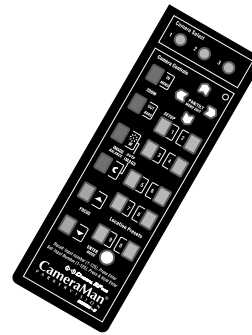

3-CCD Camera Control Keypad



PVTV DIGITAL SHOT Director



CameraMan Tally Light



PVTV SCRIPT Viewer Display

3-CCD DIGITAL Camera Components

Below is a description of each part that came with the CameraMan 3-CCD DIGITAL Camera.

CameraMan 3-CCD DIGITAL Camera

The camera and its integrated intelligent pan/tilt system is the primary component, and the basis for all CameraMan camera systems.

The 18x version of the 3-CCD DIGITAL Camera includes a rectangular lens shroud. See Appendix H: page 24 for instructions on how to install the shroud.

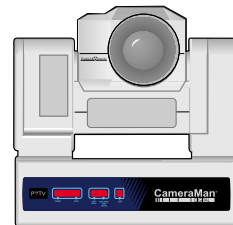
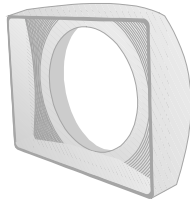

Front View of CameraMan 3-CCD DIGITAL Camera

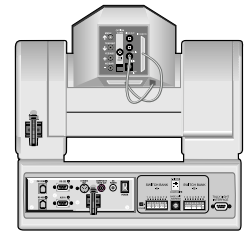

Rear View of CameraMan 3-CCD DIGITAL Camera

Mini Docking Station

The Mini Docking Station should be attached to the back of the camera. This box is the point of connection for all RS-232 and RS-485. The only time this box needs to be removed is if the camera is upgraded to a Presenter Camera System.

Note: If a Presenter or Deluxe Camera System was purchased, the Mini Docking Station is not needed.

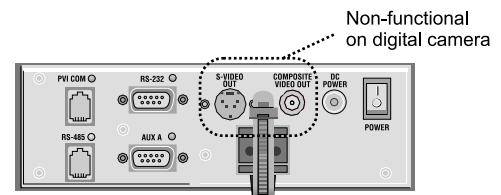

Mini Docking Station

CameraMan Power Supply

The included power supply enables use with 50/60 Hz, 100-240V Power sources.

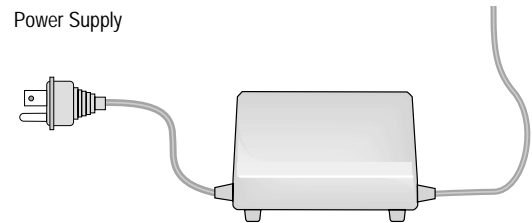

Connection Accessories

- RS-485 Connector "T"
- 3' CameraMan Communication Cable
- 25' CameraMan Keypad Cable

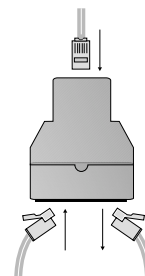

Top of T-connector with RS-485 cables.

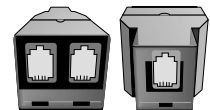

Front and back of T-connector

CameraMan Ports and Jacks

The back of the CameraMan 3-CCD DIGITAL Camera has a variety of ports and jacks used to connect the camera to other video, audio, and camera control components in a system.

- ▼ **MENU** – Turns on the on-screen menu for appearance adjustments. Also used to scroll upward through the on-screen menus.
- ▼ **ITEM/AWC** – When in shooting mode, the automatic white balance control can be set with this switch. It can also be used to scroll downward through the on-screen menus.
- ▼ **YES/ABC** – When in shooting mode, the automatic black balance control can be set with this switch. It is also used to display and increase the value of the sub-menus of the main on-screen menu.
- ▼ **NO/BAR** – When in shooting mode, the color bar and the shooting conditions are alternately indicated by pressing this switch. This is also used to scroll downward through, or lower the value of sub-menu items.
- ▼ **SDI OUT** – A digital video signal is provided at this BNC connector.

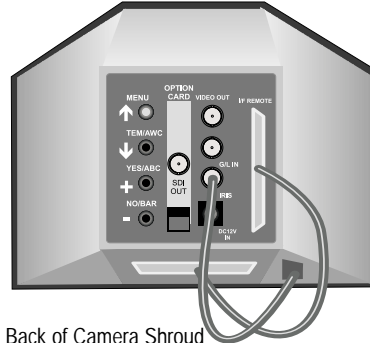

Back of Camera Shroud

- ▼ **VIDEO OUT** – This is an ANALOG Video Out signal which is utilized to view the on-screen menus.
- ▼ **G/L IN** – A GEN LOCK BNC connector used to synchronize the camera by connecting it to the network's Video Timing Source.
- ▼ **IRIS** – Input terminal for lens iris control.
- ▼ **DC12V IN** – Not Used.
- ▼ **I/F REMOTE** – Allows communication with the pan/tilt unit.

Ports and Jacks

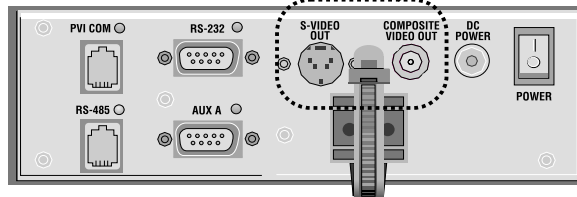

Non-functional on digital camera

- ▼ **PVI COM Jack**– Used by certain devices as a communication interface to the camera system. (For example, a hard-wired keypad would attach here). This is a standard 6-conductor RJ-11 jack.
- ▼ **RS-485 Jack**– Used for RS-485 communications between the camera system and other devices. This jack can be used to network multiple cameras or to connect appropriate, approved peripherals using a T-connector. This is a standard 4-position modular handset jack.
- ▼ **Auxiliary Communication Port**– Provides communications to select peripherals and provides capability for future expansion.
- ▼ **RS-232 Port**–Provides RS-232 communications to external devices such as PC's or other vendor control systems. This connector is a standard DB-9 (female) connector.

- ▼ **S-Video Jack**– Non-functional.
- ▼ **Cable Restrainer**– Helps keep cables from becoming disconnected, or hindering the pan and tilt capabilities of the camera.
- ▼ **Composite Video Jack**– Non-functional.
- ▼ **DC Power Jack**– Power input for the CameraMan Camera. Plug only the supplied power supply into this jack. No other types of power supplies should be used.
- ▼ **Power**– Used to power on/off the CameraMan Camera.

CameraMan LED Displays

On the front of the DIGITAL CameraMan 3-CCD Camera, there are several LEDs. These indicate various functions that are being performed by the camera. Below is a description of each.

When the camera is first powered ON, all LEDs will illuminate. During this time, basic system hardware checks are being performed. These checks include communication with the camera interface board which verifies proper installation of the camera block on the pan/tilt unit. After the initial system checks are completed, the LEDs will turn on and off one by one in a binary pattern. This pattern represents the progress the camera is making during hardware initialization. During this initialization, pan/tilt positions and camera settings are being restored. Once initialization is complete, the camera LEDs will represent the following functions:

- ▼ **Power**-- Indicates that the camera has an active power supply and is powered ON.
- ▼ **Setup**-- The camera is in the camera setup mode.
- ▼ **COM**-- Indicates that the camera is receiving valid network data on a communication link (the LEDs on the back of the camera only indicate line activity, not valid data).
- ▼ **autoTRACK**-- Indicates that the camera is in autoTRACK mode. The IR spinners are running and the camera is attempting to acquire data from the TRP.
- ▼ **Tracking Unit Status**-- Indicates that the camera has acquired the RF signal from the TRP and is receiving valid data. When this LED is OFF, TRP power is usually OFF.
- ▼ **Lock**-- This LED is used in the CLK/PLK package option only. There are two types of keypads in this package: the Personal Locator Keypad and the Chairman Locator Keypad. The Chairman Locator Keypad has lock/unlock buttons on it that enable the CLK operator to disable or override the PLK users. The LED is illuminated when the CLK operator has disabled the PLK keypads by pressing the LOCK button on the CLK keypad.

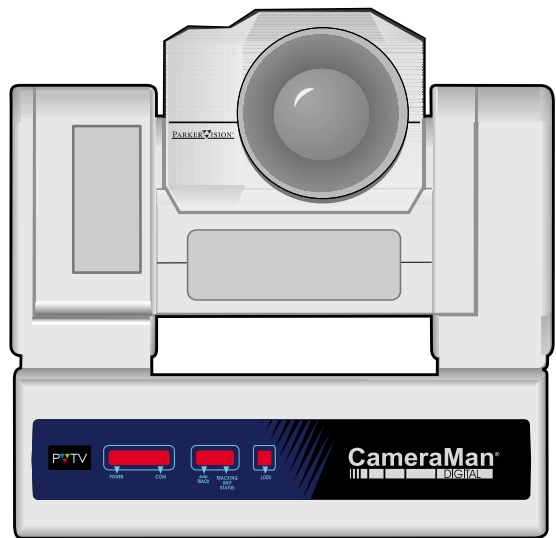

CameraMan Configuration Switches

Behind the configuration plate on the lower right side rear of the 3-CCD DIGITAL Camera is the configuration panel. These DIP and rotary switches are used to link the camera's settings to other components in the system.

! **Note:** After changing any switch's settings, turn the camera off, then back on to activate the change. Refer to page 12 for Dip Switch configuration.

Switch Bank A

- ▼ **Switch 7 (Baud Rate Switch)**– Used to change the camera's Baud Rate.
- ▼ **Switch 8 (Memory Lock Select Switch)**–Can be used to prevent programmed settings from being accidentally overridden.
- ▼ **Switches 1, 2, 3, 4, 5 and 6**– Reserved for future use.

Center Control Switches

- ▼ **Video Select Switch**–Non-functional.
- ▼ **Base Unit Address**–Used to configure the address of the Camera.

Switch Bank B

- ▼ **Switch 1 (Protocol Select Switch)** – Used to select the type of Protocol being used for RS-232 and RS-485 communications. This can be configured as either Basic or High Reliability.
- ▼ **Switch 4 (RF Commands Switch)** – Used to enable or disable the RF Receiver in the CameraMan camera.
- ▼ **Switch 5 (Preset Save)** - Used to determine how the preset settings will be saved.
- ▼ **Switch 8 (Interlink Switch)** – Used to disable commands from being sent on the RS-485 bus to other CameraMan devices.
- ▼ **Switches 2, 3, 6 and 7**– Reserved for future use.
- ▼ **Tally Light Interface Port**- Provides output and external control for CameraMan Tally Light.

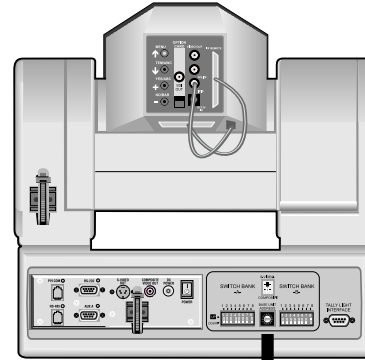

Back of 3-CCD DIGITAL Camera

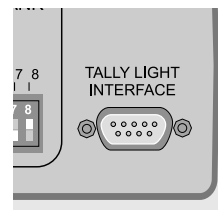
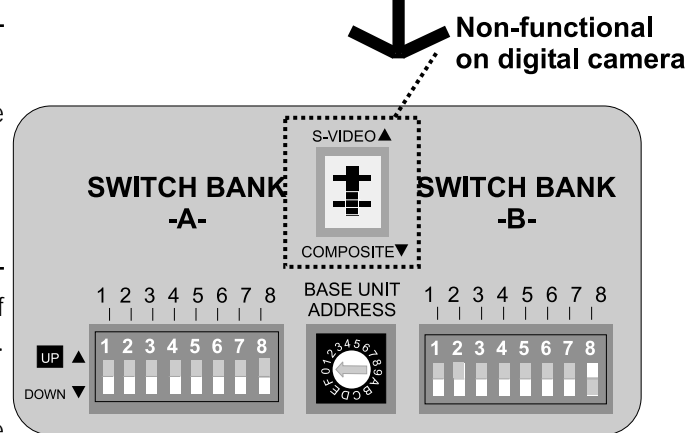

Mounting the CameraMan 3-CCD DIGITAL Camera

Mount the DIGITAL Camera on any flat, non-slick, non-metal surface with a minimum supporting area of 8"x8" by following these easy steps.

Step 1: Check the selected camera-location to ensure that there is enough camera and cable clearance space (right) for the CameraMan to pan and tilt without obstruction.



Note: Do not mount the camera upside down, or with more than a 10° angle from horizontal.



Tip: See Appendix E: FIELD OF VIEW SPECIFICATIONS on page 18, to assist in placing the CameraMan to achieve optimum optical views.

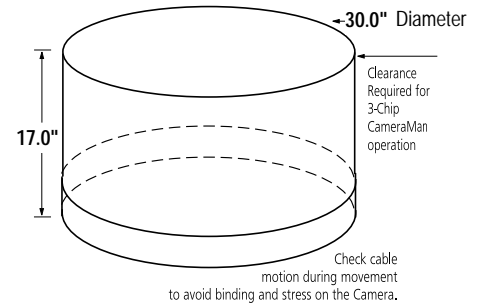

Step 2: Locate the zero-degree position mark labeled FRONT on the bottom of the base unit. This mark helps ensure that the base unit is calibrated correctly. Point this indicator mark in the direction that best reflects the center of travel in which the camera will be used (usually the center of the room).

Step 3: To ensure that the camera-mounting is not prone to vibrations, securely fasten the camera to a rigid flat surface using a 1/4"-20 UNC cap screw that does not extend into the base platform by more than 0.4". (The screw hole is provided in the base platform for this purpose. The cap screw is not provided.) This screw should be hand-tightened. If necessary, use a non-hardening threadlock to prevent the screw from loosening.



Note: Be sure to take environmental conditions into consideration when operating the camera. Always operate the camera indoors, and follow the temperature and humidity specifications outlined in Appendix C: CAMERA SPECIFICATIONS on page 16.

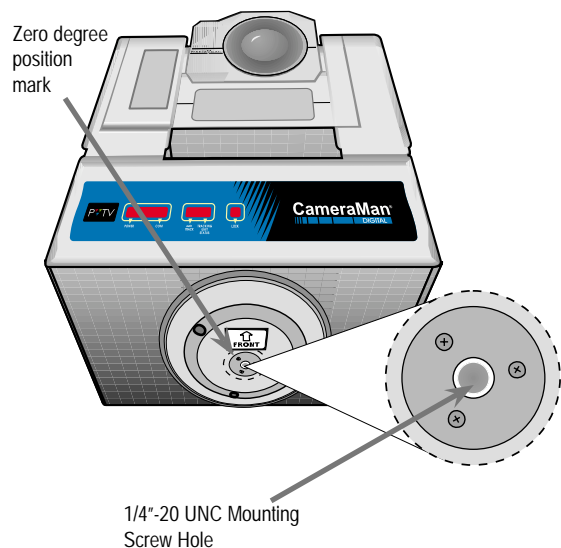

Connecting to the Camera System

Follow the instructions below to begin connecting the camera to the system.

Tip: After connecting each cable to the camera, let it hang loosely behind the camera. Then follow the instructions in the “Restraining the Cable Connections” section before attaching the other ends of the cable to other equipment. This will relieve undue stress on the cables, allowing the camera to move freely.

Connecting The Camera Control Cables

On the back of the camera shroud, there are two cables. These control the camera’s lens, power and video signals. *These must be attached for the camera to operate properly.*

- Connect the 12-pin male connector (#1) to the IRIS jack.
- Connect the 50-pin SCSI connector (#2) to the I/F REMOTE jack.

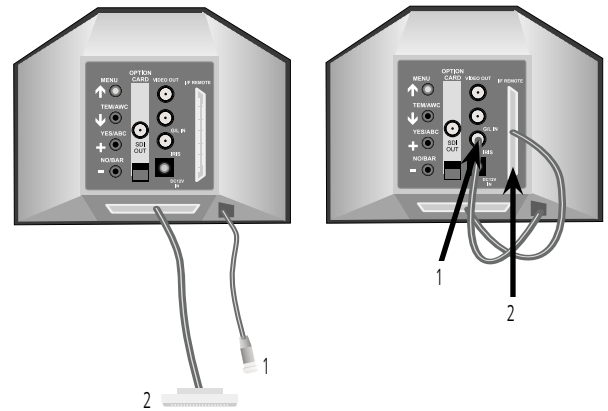

Connecting The SDI Video Output

The 3-CCD DIGITAL Camera supports SDI format (270 Mbls component out).

Connect to the BNC jack labeled SDI OUT on the back of the camera shroud, using a standard SDI coaxial cable with a BNC connector.

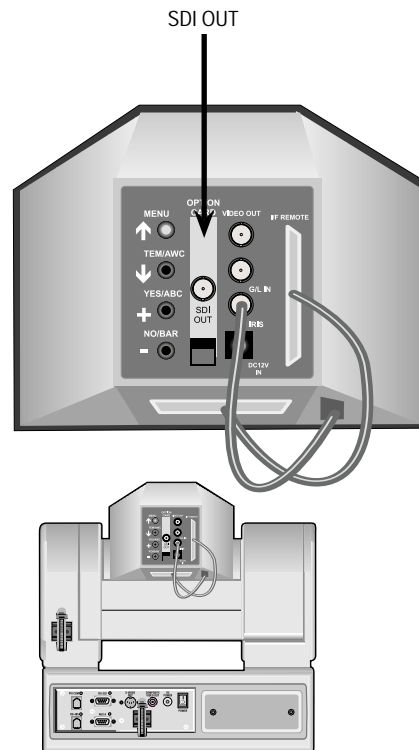

Rear View of DIGITAL Camera

Connecting to the Camera System

Connecting To The RS-232 Port

The 3-CCD DIGITAL Camera provides for RS-232 communications using the DB-9 jack on the back of the camera, labeled RS-232. This RS-232 port can be used to control the CameraMan Camera from external devices such as a PC or other vendor control system (i.e.: AMX, Crestron). Connect to this port using a standard computer cable with a DB-9 connector. When used with a PVTV DIGITAL SHOT Director, this port operates at 19,200 Baud, No Parity and software hand-shaking using High Reliability protocol. Otherwise, the port operates at 9600 Baud, No Parity, and software hand-shaking using High Reliability or Basic protocols.

! **Note:** To verify which protocol is being used, check the PROTOCOL switch on the configuration panel on the back lower-right of the DIGITAL Camera.

💡 **Tip:** The COM light above the RS-232 port is used to indicate communication activity.

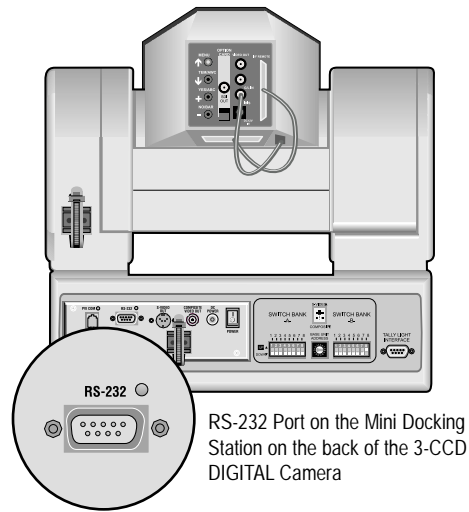

RS-232 Port on the Mini Docking Station on the back of the 3-CCD DIGITAL Camera

Connecting Camera Control Devices

There are several ways to control the CameraMan's movement. The information below explains how to connect and configure the optional Camera Control Keypad, or the PVTV DIGITAL SHOT Director.

 **Tip:** For the DB-9 pinout port information, see the Appendix D: PIN-OUT DIAGRAMS.

Connecting Optional Camera Control Devices

 **Note:** Do not use the Camera Control Keypad and the CameraMan SHOT Director at the same time

Camera Control Keypad (or Tracking System Keypad)

The optional Camera Control Keypad controls the camera's movement via wireless RF technology (up to 60 feet), or hard-wired connection (up to 250 feet). If you choose to use a Camera Control Keypad in the hard-wired mode, follow these directions for installation.

1. Using the 25' CameraMan Keypad Cable included with your camera, connect one end of the cable to the RJ-11 type jack located in the battery compartment of the keypad.
2. Connect the other end of the cable to the RJ-11 type jack on the back of the camera, labeled PVI COM.

 **Tip:** When the system is powered on, the light on the keypad should illuminate momentarily, indicating the keypad is ready for operation. The light located above the PVI COM port is used to indicate communication activity.

 **Note:** Using cable other than the supplied cable for the PVI COM port may cause damage.

PVTV DIGITAL SHOT Director

The optional PVTV DIGITAL SHOT Director multi-camera controller can be connected in hard-wired mode only. Follow these directions to connect the DIGITAL SHOT Director to the CameraMan.

1. Using a standard RS-485 cable, connect one end of the cable to one of the RS-485 jacks (either one) on the back of the Shot Director.
2. Connect the other end of the cable to:
 - The jack labeled RS-485 on the back of the CameraMan connector box for single camera applications, or
 - The T-Connector for multiple-camera applications. Then use the provided 3' CameraMan Communication Cable to connect the T-connector to the camera's RS-485 jack.

 **Note:** If using a Camera Control Keypad or DIGITAL SHOT Director, refer to its operations manual. If it is unavailable, contact your local reseller.

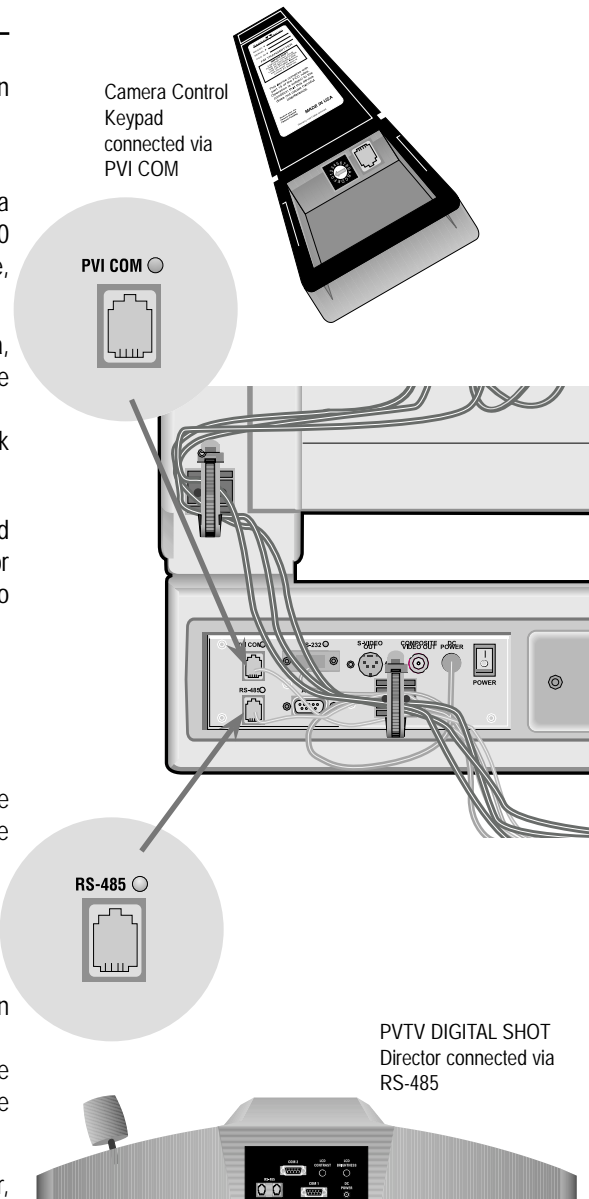

Cable Restraint and System Power

Notice that if left alone, the connected cables may impede the camera's movement. To combat this, the 3-CCD DIGITAL Camera comes equipped with two cable restrainers on the left back, and on the Mini Docking Station. Follow the instructions below to properly restrain the cables and power-up the camera.

Restraining The Cable Connections

For upper (ie GEN LOCK) cable connections (if used)

1. Locate the cable restraint on the back left side of the camera.
2. Insert cable(s) through the cable restraint from left to right.

! Note: Allow 16" of cable between the restraint and the connection port to provide enough slack for the camera's tilting movement.

3. Tighten the restraint by pulling on the strap's "free" end to prevent any cable from becoming dislodged. (the cable restraint is reusable and adjustable).
4. Group the cables with all the other cables connected to the connector box and follow the instructions below to feed them through the lower cable restraint.

For lower cable connections

1. Insert all cables (upper and lower) through the cable restraint from left to right. This will result in the cables being located approximately in the center of the camera, instead of near the edge.
2. Tighten the restraint by pulling on the strap's "free" end to prevent any cable from becoming dislodged.

! Note: To relieve undue stress on the camera and the cable connections, it is important to fasten all cables using the cable restrainer on the back of the camera.

! Note: Be sure to leave enough slack in the cables for the camera to pan left and right free of any constraints.

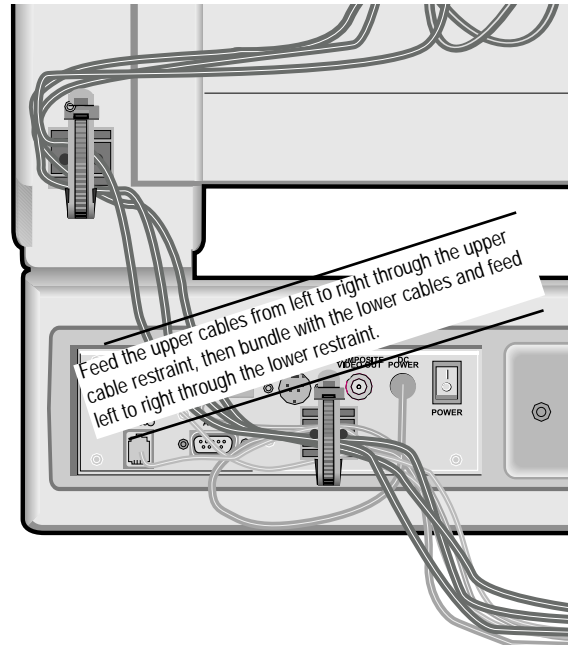

Connecting The Power Supply

Mount the Power Supply with any orientation, or on top of a table or roll-about unit by using the following steps.

1. Verify that the POWER switch, on the back of the camera, is turned OFF.
2. Plug the 5.5mm female connector from the power supply cord into the DC POWER jack in the back of the camera.
3. Connect the other end of the power supply into a 120 VAC source.

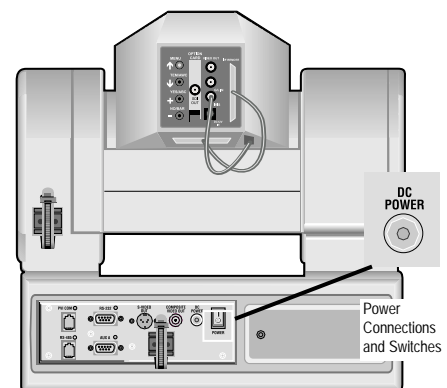

Switch Configuration

Now that CameraMan is connected to the power supply and control devices, the DIGITAL Camera must be configured to work in the desired application. To begin, remove the configuration plate on the back right side of the camera by removing the two screws holding it in place. Behind it are the configuration switches. From left to right, they are:

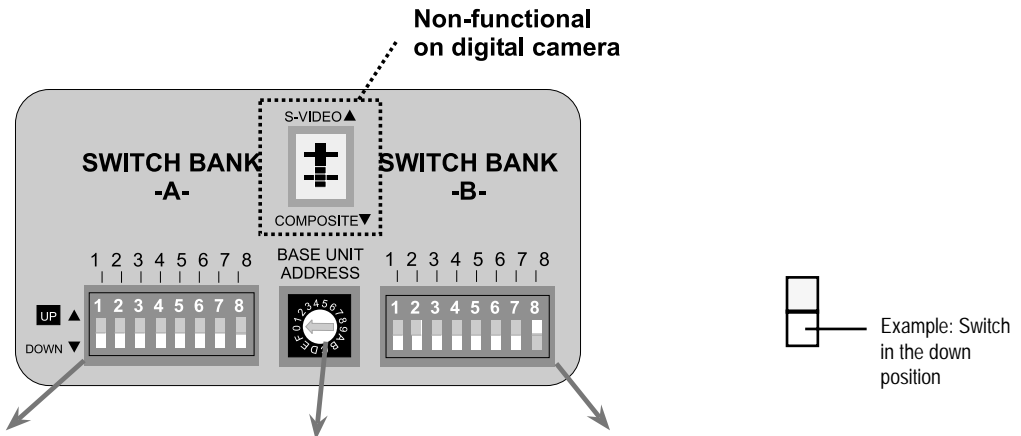

Switch Bank A	Central Control Switches	Switch Bank B
<p>Dip Switch 7 (Baud Rate) This switch is used to configure the camera's Baud Rate for the RS-232 and RS-485 ports. Switch UP for 19,200 and DOWN for 9600. (factory default: UP)</p> <p>Dip Switch 8 (Memory) For the majority of applications, this switch should be set to UNLOCK (UP). When DOWN, all programmed features are locked and cannot be overridden. (factory default: UP)</p>	<p>Base Unit Address Use the 16-position rotary switch labeled BASE UNIT ADDRESS to set the unique identification number for this CameraMan. If using the optional Keypad, DIGITAL SHOT Director, or another control system, refer to the documentation provided with those accessories for proper configuration.</p> <p> For setting up a camera network, see page 15, Appendix B: MULTIPLE CAMERA APPLICATIONS.</p>	<p>Dip Switch 1 (Protocol) Select the communication protocol which will be used by the RS-232 and RS-485 ports on the camera. The High Reliability protocol includes some advanced error checking that is not performed in the Basic protocol. (factory default: DOWN)</p> <p>Dip Switch 4 (RF Command) When this switch is DOWN, the camera responds to commands sent from an RF Keypad. When it is UP, the RF receiver in the camera is disabled and the camera cannot receive commands directly from a wireless keypad. (factory default: DOWN)</p> <p> When using multiple cameras networked on the RS-485 bus, only one camera should have its RF receiver enabled. Set switch 4 on the other cameras to UP.</p> <p>Dip Switch 5 (Preset Save) Use this switch to determine how the preset settings will be recalled. DOWN recalls your Manual Gain, Iris, and Focus settings. UP recalls only the Auto settings for presets and autoTRACK Views. (factory default: DOWN)</p> <p>Dip Switch 8 (Interlink) Use this feature in multi-camera applications. When it is DOWN, all commands will be passed onto the RS-485 communication bus to the appropriate camera. For a single-camera application, the setting of this switch does not matter. (factory default: DOWN).</p>

All switches not discussed on this page should remain in the DOWN or OFF position.

System Startup

Once all necessary connections and configurations are made, you are ready to turn on the system.

Powering On

1. Just switch the Power button on the back of the CameraMan DIGITAL Camera to the ON position. The Camera should automatically enter its position calibration mode and then stop at the zero degree point.
2. Verify that the camera is now facing in the direction the "FRONT" label was pointing during mounting (see page 7).
3. If you are using the optional Camera Control Keypad or DIGITAL SHOT Director, make sure its base unit address is the same as on the camera. If they are, verify that the camera's PAN and TILT functions are working properly.



Tip: If the camera does not move, refer to the TROUBLESHOOTING section of the Camera Control Keypad, or DIGITAL SHOT Director manual.

If using more than one CameraMan 3-CCD DIGITAL Camera, they need to be set up in a "daisy-chain" network

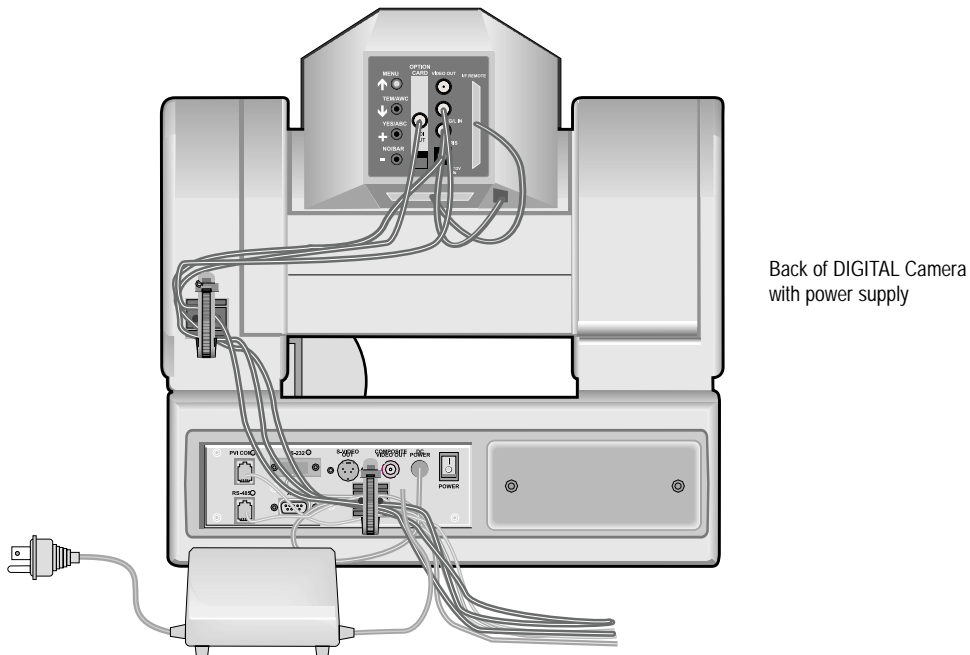

Appendix A: Troubleshooting

Should any problems occur with the CameraMan 3-CCD DIGITAL Camera, please refer to the following guide. If questions or problems still exist after troubleshooting, please contact your authorized, or contact Customer Support directly at (904) 596-3500.

Problem: *The Camera's Video is not working properly.*

- Solution:**
1. Verify that the SDI OUT connection is being used on the back of the camera shroud.
 2. Verify that the video output of the camera is connected to the appropriate video input on the switcher or CODEC.

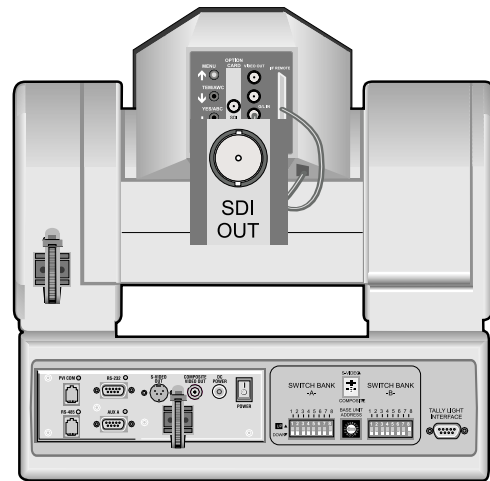

Back of 3-CCD CameraMan with configuration plate removed

Problem: *No communications through the RS-232 port.*

- Solution:**
1. Verify that the cable being used is wired correctly. (see page 17)
 2. Verify that the PROTOCOL SELECT switch on the rear configuration panel is set properly. (see page 12)

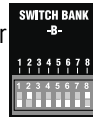

3. Verify that the BASE UNIT ADDRESS on the rear configuration panel is set properly.



4. Does the COM light above the RS-232 port on the back of the camera blink when you send a command through this port? If no, change the cable and retry.

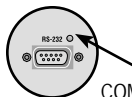

COM light on RS-232 Connection

5. Verify that the POWER LED, on the front of the camera, is illuminated. Also verify that the 12VDC indicator, on the rear of the camera block, is illuminated. If the POWER LED is not lit, check the POWER switch to make sure that it is ON, then verify that the Power Supply is connected to the camera properly. If the 12VDC LED on the rear of the camera block is not illuminated, verify that the I/F Remote SCSI cable is connected properly.

Appendix B: Multi-Camera Applications

configuration by following these steps:

1. Connect the cameras together by plugging the T-connector into the RS-485 port on the back of the camera.
2. Connect each camera using a 4-conductor cable, with 4-position modular handset plugs wired "straight-through":

Pin 1 Pin 1
Pin 2 Pin 2
Pin 3 Pin 3
Pin 4 Pin 4

! **Note:** Do NOT use a standard phone cable, as these are wired differently and may cause damage.

3. Using the BASE UNIT ADDRESS rotary switch, which is located on the back of the Camera, configure each camera with a unique Base Unit Address. (i.e.: Camera One would be set with address 0, Camera Two would be set with address 1, and so on)
4. In order to control each camera with your Camera Control Keypad, the rotary switch inside the keypad battery compartment must match the lowest Base Unit Address in your system. For example, if the Base Unit Address switches are set according to the illustration to the right, the rotary switch inside the keypad should be set to zero. The Camera Control Keypad can control up to three cameras.

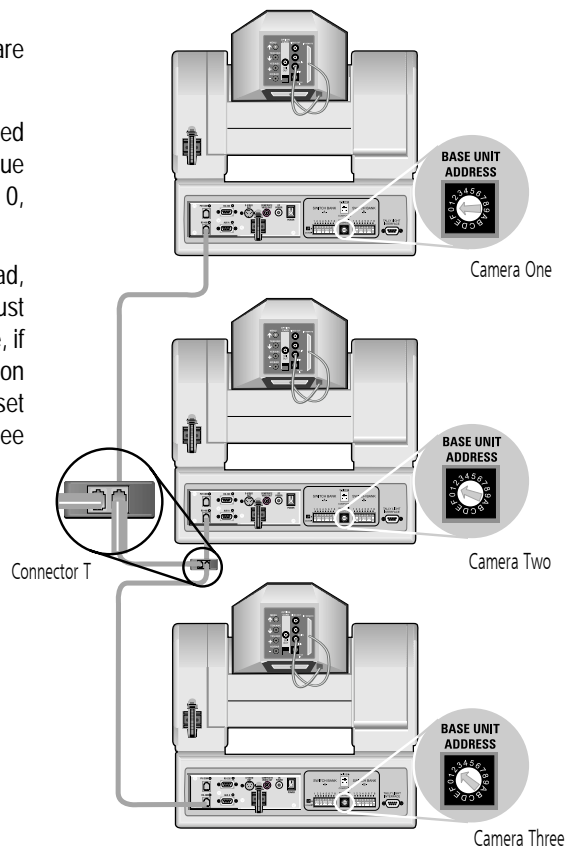

Appendix C: Camera Specifications

This device complies with part 15 of the FCC rules. Operation is subject to the condition that this device does not cause harmful interference. FCC identifier: JFECM003-AA.

3-CCD DIGITAL Camera

3-CCD DIGITAL Camera (1/2" CCD)

Image Sensor:.....(3) 1/2" interline, supersensitive CCD
Hor. Resolution:.....850 TV Lines (high band, DTL ON)
Aspect Ratio:.....4:3
Pixels:.....768 (H) x 494 (V) pixels
S/N Ratio:.....65 dB (DNR on)
Scanning:.....2:1 interlace
System:.....NTSC
Scanning Frequency: 15.734kHz (hor), 59.94 Hz (vert)
Synchronizing:.....Internal or external
Sensitivity:.....2000 lx, F11, 3200 K
Min. Illumination:.....0.25 lx, F1.4, Night Eye HIGH mode
Registration:.....0.05%
Contour Correction:.....Horizontal and Vertical
White Balance:.....Auto (2 memories), 3200K, 5600K,
.....Fine Man, ATW
Black Balance:.....AUTO
Color Bar:.....SMPTE color bar (Setup 0/7.5)
Shutter Speed:.....Synchro Scan:60.34 Hz-15.75 kHz
Step Shutter:.....OFF, 1/100, 1/250, 1/500, 1/1000,
.....1/2000, 1/4000, 1/10000 s ELC
Gain:.....AGC low/high, 0 - 30 dB, Night Eye Low/High
Iris:.....Auto, Manual
Temperature:.....-10° to 45° C
Humidity:.....20 to 90% Non-condensing
Dimensions:.....US: 14"L x 13.5"W x 10.75"H
.....INT:35.6cm L x 34.3cm W x 27.31cmH
Zoom Ratio:.....18x
Focal Length:.....6.7 - 121mm
Angular F.O.V.:.....51.1° x 39.4° (wide)
.....3.03° x 2.27° (tele)
Maximum Relative Aperture.....1:1.4 (f=6.7-91mm),
.....1:1.85 (f=121mm)

3-CCD Switchable DIGITAL Camera (2/3" CCD)

Image Sensor:.....(3) 2/3" interline, supersensitive CCD
Hor. Resolution:.....850 TV Lines (high band, DTL ON)
Aspect Ratio:.....4:3, 16:9 switchable
Pixels:.....948 (H) x 485 (V) pixels
S/N Ratio:.....62 dB (DNR on)
Scanning:.....2:1 interlace
System:.....NTSC
Scanning Frequency: 15.734kHz (hor), 59.94 Hz (vert)
Synchronizing:.....Internal or external
Sensitivity:.....2000 lx, F9.5, 3200 K
Min. Illumination:.....2.0 lx (F1.7 + 30dB)
Registration:.....0.05%
Contour Correction:.....Horizontal and Vertical
White Balance:.....Auto (2 memories), 3200K, 5600K,
.....Fine Man, ATW
Black Balance:.....AUTO
Color Bar:.....SMPTE color bar (Setup 0/7.5)
Shutter Speed:.....Synchro Scan:60.34 Hz-15.75 kHz
Step Shutter:.....OFF, 1/100, 1/250, 1/500, 1/1000,
.....1/2000, 1/4000, 1/10000 s ELC
Gain:.....AGC, 0 - 30 dB, Night Eye
Iris:.....Auto, Manual
Temperature:.....-10° to 45° C
Humidity:.....20 to 90% Non-condensing
Dimensions:.....US: 14"L x 13.5"W x 10.75"H
.....INT: 35.6cm L x 34.3cm W x 27.31cmH
Zoom Ratio:.....18x
Focal Length:.....9 - 162mm (16:9),
.....10.8-194mm (4:3)
Angular F.O.V (16:9).....52.1° x 40.3° (wide),
.....3.11° x 2.33° (tele)
Angular FOV (4:3).....44° x 34°(wide), 2.6° x 1.9° (tele)
Maximum Relative Aperture.....1:1.4 (f=9.0-117mm),
.....1:2.5 (f=162mm)

BOTH CAMERAS

Mechanical

Mechanical Drives:.....WhisperDRIVE Plus™ Rated For
5000 Hrs. Of Continuous Motion
Tilt:.....± 25° (Speed: 1°/Sec to 50°/Sec)
Pan:.....359° (Speed: 1°/Sec to 45°/Sec)
Location Presets:.....125
Location Preset Data:.....Pan, Tilt, Zoom, Focus, Iris
Location Preset Accuracy:.....±0.125°

Inputs/Outputs

Video Output:.....Composite: 1V[p-p] (75 ohm) BNC
.....SDI: 270Mb/s component (SMPTE 259M) BNC
External Sync Input:.....BB (BNC)
RS-232 Port:.....DB-9(F) Connector
RS-485 Port:.....Bus Up To 16 Cameras
.....(4 pos. RJ handset port)
Power:.....100-240VAC Power Supply
.....100 W Maximum Consumption

CameraMan Clearance

The minimum dimension for the CameraMan is a circular diameter of 30". This accounts for both camera and cable clearance. Check cable movement to avoid binding and stress on the camera.

Appendix D: Pin-Out Diagrams

The following pinout connections can be found on the back of the Mini Docking Station on the rear of the CameraMan. These diagrams are for reference.

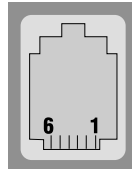

PVI COM
RJ-11

Pin	Signal
1	12v
2	12v
3	Ground
4	Signal A
5	Signal B
6	Ground

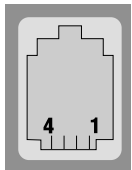

RS-485
Four position
Modular
Handset

Pin	Signal
1	Ground
2	Signal A
3	Signal B
4	Ground

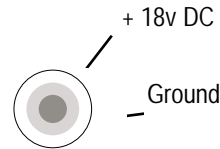

5.5mm DC
Power
Connector

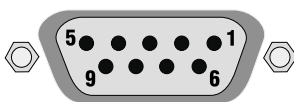

RS-232
9-pin Female D-9
Sub

Pin	Signal
2	Transmit
3	Receive
5	Ground
1,4,6-9	Not Used

Appendix E: Field-Of-View Specifications

The reference charts below represent the size of the field of view and angle of view from various distances and with different lenses.

18 x 6.7 Lens on Standard 4:3 DIGITAL Camera:

Dist. from Lens (feet)	No Zoom			Full Zoom		
	Hor. (ft)	Vert. (ft)	Square Feet	Hor. (ft)	Vert. (ft)	Square Feet
10	9.56	7.16	68.47	0.53	0.40	0.21
15	14.34	10.74	154.05	0.79	0.59	0.47
20	19.12	14.32	273.87	1.06	0.79	0.84
25	23.90	17.90	427.91	1.32	0.99	1.31
30	28.68	21.48	616.20	1.59	1.19	1.89
35	33.46	25.06	838.71	1.85	1.39	2.57
40	38.54	28.64	1095.46	2.12	1.58	3.35
45	43.02	32.22	1386.44	2.38	1.78	4.24
50	47.80	35.81	1711.66	2.64	1.98	5.24
55	52.59	39.39	2071.10	2.91	2.18	6.34
60	57.37	42.97	2464.79	3.17	2.38	7.55
65	62.15	46.55	2892.70	3.44	2.58	8.86
70	66.93	50.13	3354.85	3.70	2.77	10.27
Angle of view	51.10°	39.40°		3.03°	2.27°	

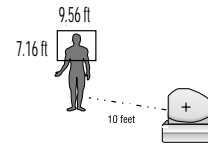

Example of distance's impact on field of view: taken from Standard Lens Table (10 feet and 20 feet)

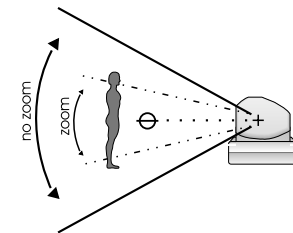
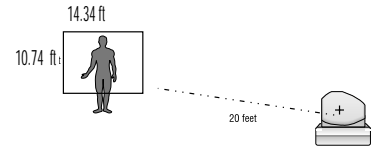

18 x 9 Lens on 16:9/4:3 DIGITAL Camera switched to 4:3 Aspect Ratio:

Without 0.8 Wide-angle Crossover Adaptor

Dist. from Lens (feet)	No Zoom			Full Zoom		
	Hor. (ft)	Vert. (ft)	Square Feet	Hor. (ft)	Vert. (ft)	Square Feet
10	8.18	6.11	50.03	0.46	0.35	0.16
15	12.27	9.17	112.57	0.69	0.52	0.36
20	16.36	12.23	200.12	0.92	0.69	0.63
25	20.46	15.29	312.69	1.15	0.86	0.99
30	24.55	18.34	450.28	1.38	1.04	1.43
35	28.64	21.40	612.88	1.61	1.21	1.94
40	32.73	24.46	800.50	1.84	1.38	2.54
45	36.82	27.52	1013.13	2.07	1.56	3.21
50	40.91	30.57	1250.78	2.30	1.73	3.97
55	45.00	33.63	1513.44	2.53	1.90	4.80
60	49.09	36.69	1801.12	2.75	2.07	5.71
65	53.18	39.74	2113.81	2.98	2.25	6.70
70	57.28	42.80	2451.52	3.21	2.42	7.77
Angle of view	44.50°	34.00°		2.63°	1.98°	

Above- Vertical angle of view:
Below- Horizontal angle of view:

no zoom= wide angle (more scenery, less specific detail)

zoom= narrow angle (less scenery, more specific detail)

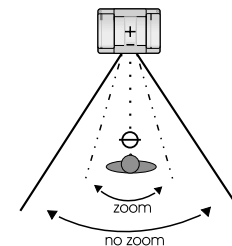

Appendix E: Field-Of-View Specifications

The reference charts below represent the size of the field of view and angle of view from various distances and with different lenses. *When the camera is switched to a 4:3 aspect ratio, the wide-angle conversion is at approximately 11mm. To obtain the conventional 4:3 view, the user must use a wide-angle 0.8 crossover adapter.*

18 x 9 Lens on 16:9/4:3 DIGITAL Camera switched to 4:3 Aspect Ratio:

With 0.8 Wide-angle Crossover Adapter

Dist. from Lens (feet)	No Zoom			Full Zoom		
	Hor. (ft)	Vert. (ft)	Square Feet	Hor. (ft)	Vert. (ft)	Square Feet
10	9.78	7.43	71.75	0.54	0.41	0.22
15	14.66	11.01	161.43	0.81	0.61	0.50
20	19.55	14.68	286.98	1.09	0.81	0.88
25	24.44	18.35	448.41	1.36	1.02	1.38
30	29.33	22.02	645.71	1.63	1.22	1.99
35	34.22	25.69	878.88	1.90	1.42	2.71
40	39.11	29.36	1147.93	2.17	1.63	3.53
45	43.99	33.02	1452.85	2.44	1.83	4.47
50	48.88	36.69	1793.64	2.71	2.03	5.52
55	53.77	40.36	2170.31	2.99	2.24	6.68
60	58.66	44.03	2582.84	3.26	2.44	7.95
65	63.55	47.70	3031.25	3.53	2.64	9.33
70	68.43	51.37	3515.54	3.80	2.85	10.82
Angle of view	52.10°	40.30°		3.11°	2.33°	

18 x 9 Lens on 16:9/4:3 DIGITAL Camera switched to 16:9 Aspect Ratio:

Dist. from Lens (feet)	No Zoom			Full Zoom		
	Hor. (ft)	Vert. (ft)	Square Feet	Hor. (ft)	Vert. (ft)	Square Feet
10	10.59	6.04	63.94	0.59	0.33	0.20
15	15.88	9.06	143.87	0.89	0.50	0.44
20	21.18	12.08	255.77	1.19	0.66	0.79
25	26.47	15.10	399.64	1.48	0.83	1.23
30	31.77	18.12	575.49	1.78	0.99	1.77
35	37.06	21.13	783.30	2.08	1.16	2.41
40	42.36	24.15	1023.09	2.37	1.33	3.15
45	47.65	27.17	1294.84	2.67	1.49	3.99
50	52.95	30.19	1598.57	2.97	1.66	4.92
55	58.24	33.21	1934.27	3.26	1.82	5.95
60	63.54	36.23	2301.94	3.56	1.99	7.09
65	68.83	39.25	2701.59	3.86	2.16	8.32
70	74.13	42.27	3133.20	4.16	2.32	9.65
Angle of view	55.80°	33.60°		3.40°	1.90°	

Appendix F: The 18x Lens Shroud

The 18x version of the CameraMan 3-CCD DIGITAL Camera comes equipped with a rectangular lens shroud. The shroud helps to keep out glares from light sources located on the sides of the camera.

Installing the Shroud

1. Locate the red dots on the top and bottom of the shroud, and on the lens itself.
2. Align the red dot on the shroud with the dot on the lens, then slide the shroud over the lens.
3. Tighten the shroud in place using the bolt attached to the shroud.

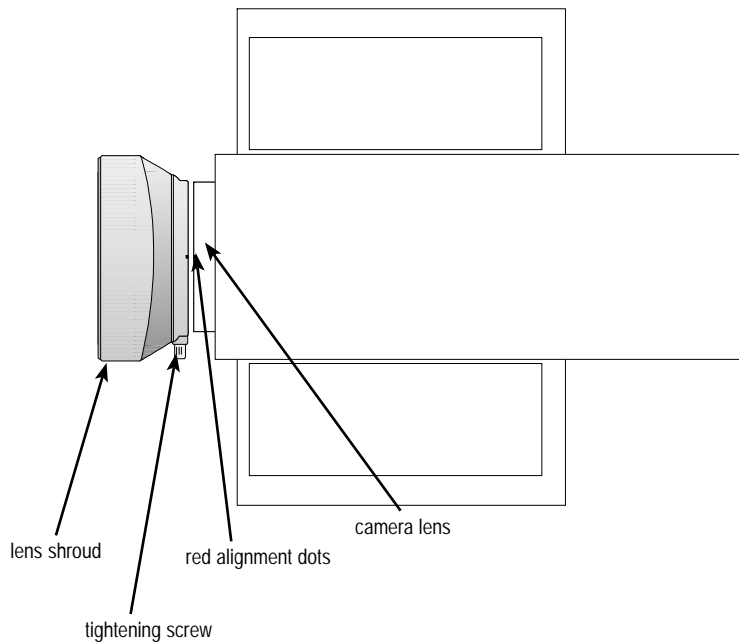

Appendix G: Typical System Diagrams

Below is a typical setup for the CameraMan camera. The items in the diagram are not to scale.

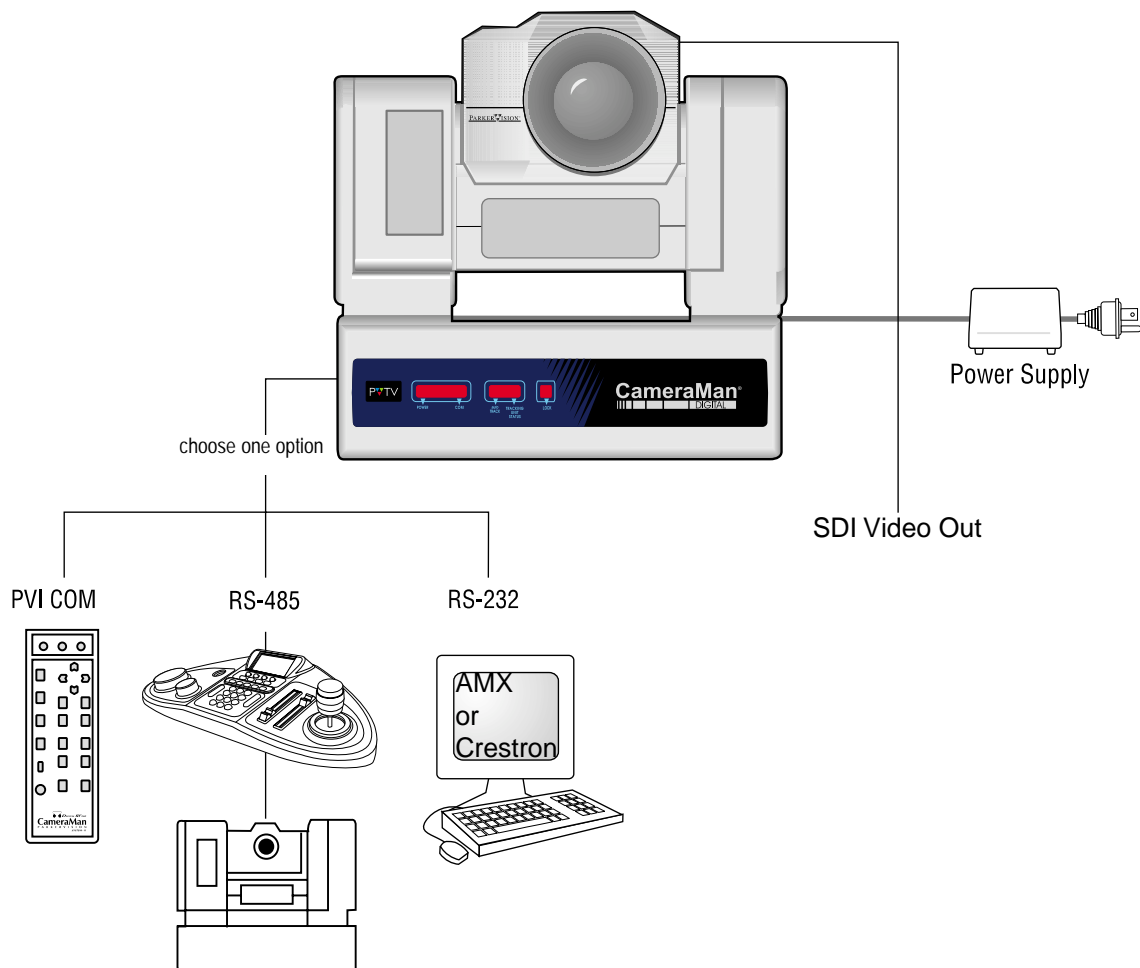

Appendix H: On-Screen Camera Menus

The 3-CCD DIGITAL Camera allows for adjustments to the camera settings via on-screen menus by using the controls on the back of the camera block, the Camera Control Keypad, or PVTV DIGITAL SHOT Director. These adjustments should be performed by qualified technical personnel only. *If your system includes a DIGITAL SHOT Director, always use the DIGITAL SHOT Director's LCD menus to make these adjustments.*

■ Use Mode Setting

The camera has four use modes, and various functions for four use modes have been preset.

Functions can be set as best suited to each use mode.

- Halogen mode
Suited to indoor shooting, such as at weddings, parties, lecture meetings, events, etc.
Settings can be changed using a simple menu.
- Fluorescent mode
Suited to indoor shooting under fluorescent lighting.
Settings can be changed using a simple menu.
- Outdoor mode
Suited to outdoor shooting.
Settings can be changed using a simple menu.
- User mode
Settings can be changed using a detail menu.

■ SETTING BY CAMERA

1. Turn the camera on while keeping the MENU switch depressed.
The use mode setting menu shown at right appears on the monitor screen and one of the use mode blinks.
2. Press the MENU switch, ITEM/AWC switch, or NO/BAR switch to let the desired use mode blink.
MENU switch (↑): The blinking item moves up by one.
ITEM/AWC switch (↓), NO/BAR switch (-): The blinking item moves down by one.

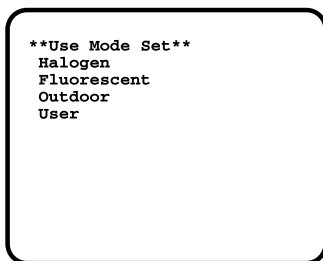

3. Press the YES/ABC switch.
The blinking use mode comes into effect. After the use mode setting menu is shown for about 5 seconds, the camera returns to be ready for operation. Then, the camera operates in the selected use mode.

! On-screen menu items can only be viewed by connecting to the analog VIDEO OUT connector on the rear of the camera block.

■ SETTING BY RCU (RCB) OR HYBRID CONTROL PANEL

An operation mode is selected depending on the position of the scene file switch.

Operation mode	Scene File Switch Position of RCU (RCB)	Scene File Switch Position of Hybrid control panel
Halogen Mode	1	1
Fluorescent Mode	2	2
Outdoor Mode	3	3
User's Mode	USER SET	4

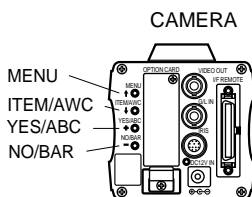

Appendix H: On-Screen Camera Menus

■ MENU ITEM SETTING

- Each of the four use modes of the camera has a main menu. (Shown at right)
- Each item of the main menu has a submenu, which consists of several settings.
- These settings have been preset to the optimum values to suit each use mode, and can be changed to suit actual shooting conditions.

■ MAIN MENU SCREEN

Main Menu of Halogen,
Fluorescent, Outdoor Mode

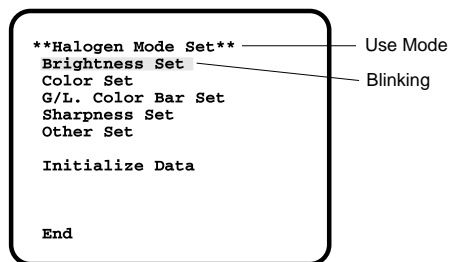

■ SETTING

1. From the camera alone:

Keep the MENU switch depressed for 5 seconds or more.

The main menu appears on the monitor screen.

2. Each time the MENU switch (↑), ITEM/AWC switch (↓), or NO/BAR switch (-) is pressed, the blinking item moves up or down.
3. When the YES/ABC switch is pressed after selecting the desired item to blink, the submenu for the selected item appears on the screen.
4. Select the desired item to be changed in its settings using the MENU switch (↑) and ITEM/AWC switch (↓).
5. Press the YES/ABC switch (+) or NO/BAR switch (-) to change the settings.
6. Select [Return] using the MENU switch and ITEM/AWC switch, then press the YES/ABC switch to return to the main menu.
7. After changing the settings, take the following steps.

Camera alone: Select [End] using the MENU switch and ITEM/AWC switch and press the YES/ABC switch.

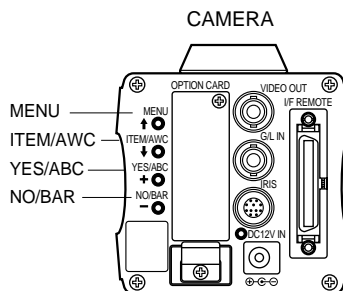

Appendix H: On-Screen Camera Menus

■ SUB MENU (Halogen Mode, Fluorescent Mode, Outdoor Mode)

<ul style="list-style-type: none"> ① **Brightness Set** ② Picture Level ±0 ③ Light PEAK/AVG 0 ④ Light Area Top cut ⑤ Auto ND (ELC) (OFF) ⑥ Auto Gain Up (OFF) ⑦ Manu Gain Up (0dB) ⑧ Pedestal (±0) ⑧ Contrast (Gamma) MID <p>Return</p>	<ul style="list-style-type: none"> ⑬ **G/L. Color Bar Set** ⑬ H Phase ±0 ⑭ SC Coarse (1) ⑮ SC Fine (±0) ⑯ Color Bar Set (7.5IRE) <p>Return</p>	<ul style="list-style-type: none"> ⑳ **Other Set** ⑳ Shutter Speed (OFF) ㉑ Syncro Scan --- ㉒ V Resolution Normal ㉓ Baud Rate 9600bps ㉔ Nega/Posi Posi <p>Return</p>
<ul style="list-style-type: none"> ⑨ **Color Set** ⑨ Chroma Level ±0 ⑩ Flesh Tone ±0 ⑪ White Bal (AWC A) ⑫ Highlight Chroma OFF <p>Return</p>	<ul style="list-style-type: none"> ⑰ **Sharpness (DTL) Set** ⑰ DTL Select Sharpness ⑱ Level (HIGH) ⑲ Noise Suppress OFF ⑳ Clean DNR OFF ㉑ DTL Flesh Tone MID <p>Return</p>	

- Settings enclosed in parentheses can be set with the RCU (RCB) switch or VR in RCU (RCB) mode.
- To return to the initial settings, refer to page 46.

■ Setting and Changing of the Setting (Halogen Mode, Fluorescent Mode, Outdoor Mode)

① Video Level Adjustment

[Picture Level: -50 - +50]

Convergence level of AUTO IRIS/AUTO GAIN UP/AUTO ND (ELC) can be adjusted.

② Detecting Ratio Adjustment [Light PEAK/AVG: P50 - A50]

The ratio of AUTO IRIS/AUTO GAIN UP/AUTO ND (ELC) detected peak to average can be adjusted within a predetermined range.

③ Photometric Measurement Method Setting [Light Area: All, Center, Top cut, BTM cut, R/L cut]

A photometric measurement method can be selected for AUTO IRIS/AUTO GAIN UP/AUTO ND (ELC).

All: All the screen area is measured.

Center: The screen is measured mainly in the center area, about one-third of both the top and bottom and one-third of both the right and left portions of the screen are excluded from measurement.

Top cut: About one-third of the top part of the screen is excluded from measurement.

BTM cut: About one-third of the bottom portion of the screen is excluded from measurement.

R/L cut: About one-third of both the right and left portions of the screen are excluded from measurement.

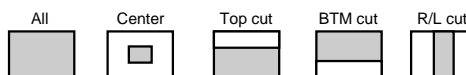

④ Auto ND (ELC) Setting [Auto ND (ELC): ON/OFF]

ON: The electronic shutter is controlled to automatically adjust the luminance.

OFF: Luminance is not automatically adjusted by the electronic shutter.

Appendix H: On-Screen Camera Menus

⑥ **Auto Gain Up Control Setting [Auto Gain Up: OFF/ LOW/HIGH]**

LOW: The Auto Gain Up control with a maximum gain increase of about 18 dB adjust the luminance automatically.

HIGH: The Auto Gain Up control with a maximum gain increase of about 30 dB operates. If the luminance is still insufficient, the Night Eye also operates to adjust the luminance automatically.

OFF: No auto gain up takes place. (Gain can be increased manually.)

⑥ **Manual Gain Up Control Setting [Manu Gain Up: 0 dB - 30 dB / NIGHT EYE]**

Manual setting is possible only when the Auto Gain Up control is in the OFF position.

0 dB: 0 dB should be selected in normal cases.

1 dB - 30 dB: Use this range if sufficient video output cannot be obtained even when the lens iris is opened in shooting dark scenes.

NIGHT EYE (Night Eye L/H): Use this mode if sufficient video output cannot be obtained even if 30 dB gain up should be selected.

Night Eye can be selected to any of two (L or H) levels.

⑦ **Black Level Setting [Pedestal: -30 - +30]**

The black level (pedestal) of the luminance (Y) signal can be set. Used in adjusting the black levels of two or more cameras.

⑧ **Contrast Adjustment [Contrast (Gamma): LOW/MID/HIGH]**

Contrast can be adjusted to any of three levels.

⑨ **Chroma Level Adjustment [Chroma Level: -3 - +3]**

Chroma Level can be decreased or increased to any of three levels each.

⑩ **Skin Color Adjustment [Flesh Tone: -3 - +3]**

Skin color can be decreased or increased to any of three levels each.

⑪ **White Balance Setting [White Bal: ATW/AWC A/ AWC B/P SET 3 200K/P SET 5 600K]**

ATW: The white balance is automatically adjusted to be always right.

AWC A, AWC B: Once the white balance is adjusted with the ITEM/AWC switch on the back of the camera, it is no longer necessary to set the white balance again if you simply select AWC A or AWC B, provided that the camera is used under the same conditions.

Fine color adjustment can be made after setting AWC by red/blue gain adjustment in user mode or from the RCU (RCB).

P SET 3 200K: The white balance is adjusted to 3 200K illumination.

P SET 5 600K: The white balance is adjusted to 5 600K illumination.

Appendix H: On-Screen Camera Menus

⑫ **Highlight Chroma Setting [Highlight Chroma: OFF/LOW/HIGH]**

At LOW or HIGH, the color dynamic range widens to prevent highlighted white portions from suppression.

⑬ **Color Bar Setup Setting [Color Bar Set: 0.0 IRE/7.5 IRE]**

The setup level of color bar can be adjusted.

⑭ **Horizontal Phase Adjustment [H Phase: -206 - +49]**

Horizontal phase can be adjusted when a genlock signal is supplied.

⑮ **Sub Carrier Phase Coarse Adjustment [SC Coarse: 1/2/3/4]**

Coarse adjustment of subcarrier phase can be made when a genlock signal is supplied.

⑯ **Subcarrier Phase Fine Adjustment [SC Fine: -511 - +511]**

Fine adjustment of subcarrier phase can be made when a genlock signal is supplied.

⑰ **Detail Select Setting [DTL Select: Sharpness/Super DTL]**

If contour correction is not sufficient at the Sharpness position when Detail Level setting ⑱ is set to LOW or HIGH, select the Super DTL position.

Note

Neither Sharpness nor Super DTL is valid for contour correction if Detail Level setting ⑱ is in the OFF position.

⑱ **Detail Level Setting [Level: OFF/LOW/HIGH]**

Detail level can be adjusted when Detail Select setting ⑰ is at Sharpness. Super DTL level can be adjusted when it is at Super DTL.

⑲ **Noise Suppress Level Setting [Noise Suppress: OFF/LOW/HIGH]**

Screen noise can be reduced when Detail Level setting ⑱ is at HIGH or LOW.

⑳ **Clean DNR Setting [Clean DNR: OFF/LOW/HIGH]**

Clean DNR effect can be selected.

㉑ **Detail Flesh Tone Level Setting [DTL Flesh Tone: LOW/MID/HIGH]**

LOW: Skin color coarseness is suppressed.

MID: Standard

HIGH: Skin color is emphasized.

㉒ **Electronic Shutter Setting [Shutter Speed: OFF/1/100 to 1/10 000 / S/Scan / Auto ND]**

OFF: Electronic shutter is turned off.

1/100, 1/250, 1/500, 1/1 000, 1/2 000, 1/4 000, 1/10 000: Electronic shutter operates at one of these speeds as selected.

S/Scan (Synchro Scan): Electronic shutter operates at the speed set with the electronic shutter synchro-scan setting ㉓.

Auto ND: Electronic shutter is controlled to automatically adjust the luminance. (ELC)

Appendix H: On-Screen Camera Menus

23 Electronic Shutter Synchro-Scan Setting [Synchro Scan: 60.34 Hz - 15.75 kHz]

This setting is possible only when Electronic Shutter setting 22 is at S/Scan.

Horizontal bar noise can be reduced by synchro-scan adjustment in shooting workstation scenes, for example.

* For luminance settings at each shutter speed and synchro-scan shutter speed, refer to the table below.

Shutter Speed	Synchro-scan	Required luminance ratio
OFF	—	1
1/100	99.68 Hz	2
1/250	250.0 Hz	4
1/500	492.2 Hz	8
1/1 000	984.4 Hz	16
1/2 000	1.969 kHz	32
1/4 000	3.938 kHz	64
1/10 000	7.875 kHz	160

24 CCD Read Out Mode Setting [V Resolution: Normal/Fine]

Normal: Normal image. (CCD storage will be by field storage.)

Fine: Vertical resolution increases. (Vertical resolution is raised without increasing residual images by frame storage and electronic shutter.

Normal is recommended for general use because sensitivity will decrease at the Fine setting.

25 PC Control Access Speed Setting [Baud Rate: 1 200 bps/2 400 bps/4 800 bps/9 600 bps]

Select a communication speed in controlling the camera from the computer.

25 Negative/Positive Selection [Nega/Posi: Posi/Nega]

Posi: Normal image

Nega: Image is shown reversed in darkness and color.

Appendix H: On-Screen Camera Menus

■ Setting to initial set

In case of the wrong setting in any use mode, take the following steps to return to the initial settings.

- (1) Select [Initialize Data] on the main menu screen of each Use Mode. (See page 29.)
Press the YES/ABC switch, then [Initialize Data] screen shown for about 10 seconds.

- (2) Press the YES/ABC switch within about 10 seconds to return to the initial settings, the existing settings are initialized, the screen shown at ②, and the camera returns to main menu.

- (3) If the NO/BAR switch is pressed, or if the YES /ABC switch is not pressed, within about 10 seconds, the screen shown at ③, and the camera returns to main menu, and the existing settings are not initialized.

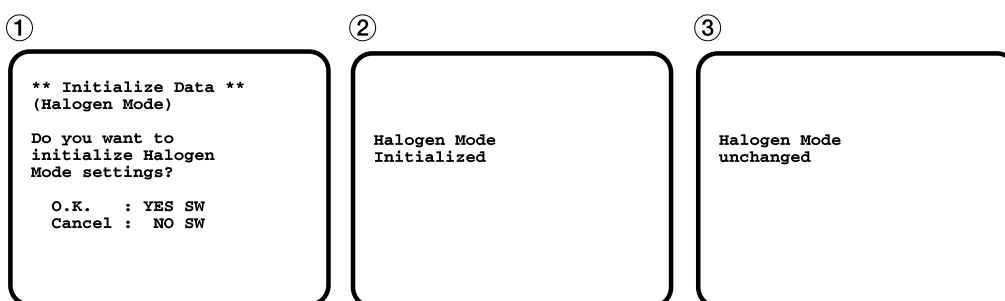

■ INITIAL SETTINGS OF THE SETTING ITEMS

(Factory preset values)

• Halogen, Fluorescent, Outdoor Mode

	Item	Halogen mode	Fluorescent mode	Outdoor mode
Brightness Set	Picture Level Light PEAK/AVG Light Area Auto ND (ELC) Auto Gain Up Manu Gain Up Pedestal Contrast (Gamma)	±0 0 Top cut OFF OFF 0dB ±0 MID	±0 0 Top cut OFF OFF 0dB ±0 MID	±0 0 Top cut ON HIGH --- -10 MID
Color Set	Chroma Level Flesh Tone White Bal High-light Chroma	±0 ±0 AWC A OFF	+1 ±0 AWC A OFF	+2 ±0 ATW OFF
G/L. Color Bar Set	H Phase SC Coarse SC Fine Color Bar Set	±0 1 ±0 7.5 IRE	±0 1 ±0 7.5 IRE	±0 1 ±0 7.5 IRE
Sharpness (DTL) Set	DTL Select Level Noise Suppress Clean DNR DTL Flesh Tone	Sharpness HIGH OFF OFF MID	Sharpness HIGH OFF OFF MID	Sharpness HIGH OFF OFF MID
Other Set	Shutter Speed Synchro Scan V Resolution Baud Rate Nega/Posi	OFF --- Normal 9600bps Posi	OFF --- Normal 9600bps Posi	Auto ND --- Normal 9600bps Posi

