

# CameraMan

ANALOG SHOT DIRECTOR

Installation and Operation Manual

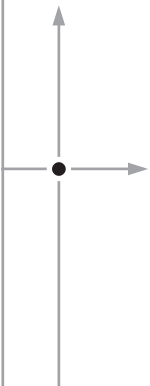

L1211101 Rev C  
1998

*the most watched worldwide*

# Contacting Grass Valley

Region	Voice	Fax	Address	Web Site
North America	(800) 547-8949 Support: 530-478-4148	Sales: (530) 478-3347 Support: (530) 478-3181	Grass Valley P.O. Box 599000 Nevada City, CA 95959-7900 USA	www.thomsongrassvalley.com
Pacific Operations	+852-2585-6688 Support: 852-2585-6579	+852-2802-2996		
U.K., Asia, Middle East	+44 1753 218 777	+44 1753 218 757		
France	+33 1 45 29 73 00			
Germany, Europe	+49 6150 104 782	+49 6150 104 223		

Copyright © Grass Valley. All rights reserved.

## Grass Valley Web Site

The [www.thomsongrassvalley.com](http://www.thomsongrassvalley.com) web site offers the following:

**Online User Documentation** — Current versions of product catalogs, brochures, data sheets, ordering guides, planning guides, manuals, and release notes in .pdf format can be downloaded.

**FAQ Database** — Solutions to problems and troubleshooting efforts can be found by searching our Frequently Asked Questions (FAQ) database.

**Software Downloads** — Software updates, drivers, and patches can be downloaded.

# Table of Contents

I. Meet Your Shot Director	
? Welcome and Icons . . . . .	1
? General Information . . . . .	2
? For Your Safety . . . . .	3
? Shot Director Components . . . . .	4
? Knob, Buttons, and Slide Controls . . . . .	5
? LCD Display, Jacks and Ports . . . . .	6
II. Connect Your Shot Director	
? Connecting to your network . . . . .	7
? Powering Up . . . . .	8
• Startup LCDs . . . . .	8
• Home LCD Menu . . . . .	8-9
• Special Home LCD Menu . . . . .	9
III. Setup Your Shot Director	
? CameraMan and Shot Director Setup	
• Setting Up Multiple-Camera Systems . . . . .	10
• Setup LCD Menu . . . . .	10
? CameraMan Setup . . . . .	11-12
? Shot Director Setup . . . . .	13
IV. Use Your Shot Director	
? Using the Controls . . . . .	14-15
? Controlling the Camera's Movement	
• Location Presets . . . . .	16
• Menu LCD menus (movement). . . . .	16
• Using autoTRACK . . . . .	17
• autoTRACK Views. . . . .	18
• Tracking Adjustments . . . . .	19
• autoTRACK LCD menus. . . . .	20-21
? Controlling the Camera's Video (3-CCD only)	
• Menu LCD Menu (video) . . . . .	22
• Camera Adjust LCD Menu . . . . .	22-28
V. Appendices	
? A: Troubleshooting. . . . .	29-30
? B: Glossary and Specifications . . . . .	31
? C: Pin-out Diagrams . . . . .	32
? D: Default Reset Settings. . . . .	33
? E: LCD Handling Precautions . . . . .	34

# Congratulations on Your Purchase

Your new CameraMan Shot Director is your key to the ultimate in camera control. The CameraMan Shot Director is designed for use with the CameraMan cameras, so you should use this manual with the Installation and Operations Manual that came with your CameraMan 1-CCD or 3-CCD camera.

## Important Note

The Shot Director is compatible only with:

- CameraMan Camera Systems with software revision 6.3 or higher.
- PRM (Programmable Response Module) software revision 2.4 or higher.

To verify the software revision number, remove its ROM card per the instructions in the camera system's Installation and Operation Manual. The revision number is located on the label of each chip. If you have any questions, please contact Grass Valley at (904) 596-3500.

## Your CameraMan Shot Director should include these components:

- One CameraMan Shot Director
- One CameraMan Shot Director Power Supply
- One 25 ft (7.6 m) CameraMan Communication Cable
- One Shot Director Installation and Operations Manual

This manual covers the connection, configuration, and operation of your new CameraMan Shot Director, which combines robotic camera control with proven autoTRACK capabilities (in autoTRACK models), location presets, and virtual CCU control for up to 16 separate cameras – all in one control unit.

The CameraMan Shot Director can store and recall up to 99 presets (125 on the 3-CCD & 2112 CameraMan cameras) and up to 15 autoTRACK views per camera. The Shot Director also offers variable pan/tilt and zoom speed through two slider adjustments for precise, smooth camera control. Its powerful backlit LCD display enables you to adjust tracking views, obtain camera movement readouts, and adjust each camera's CCU settings (3-CCD & 2112) on-the-fly without compromising the video.

If you have any questions regarding the installation or operation of your CameraMan camera, please refer to the installation and operation manual included with the camera.

You will see the following icons in this manual:



This icon alerts you to important instructions in the operation and maintenance of your CameraMan Shot Director.



This icon alerts you to tips or noteworthy suggestions in the operation, use or maintenance of your CameraMan Shot Director.



This icon refers you to the General Pan/Tilt Camera Installations and Operations Manual that came with your camera.

# General Information

---

## Important Identification Numbers

---

Before starting to assemble and use your CameraMan SHOT Director, please take a moment to find the Model and Serial number tag on your unit, and fill out the following information.

PARKERVISION™	
<b>MODEL #</b>	_____
<b>SERIAL #</b>	_____
<b>FCC ID #</b>	_____

The manufacturer reserves the right to change specifications and warranty at any time without notice or obligation.

The following section describes important material and instructions regarding the installation and use of Grass Valley equipment.

## Safety Notices

---

### Instructions to the user:

1. Do not use this apparatus near water.
2. Clean only with a damp cloth.
3. Do not defeat the safety purpose of the polarized or grounding-type plug. A polarized plug has two blades with one wider than the other. A grounding type plug has two blades and a third grounding prong. The wide blade or the third prong is provided for your safety. If the provided plug does not fit into your outlet, consult an electrician for replacement of the obsolete outlet.
4. Unplug this apparatus during lightning storms or when unused for long periods of time.
5. Refer all servicing to qualified service personnel. Servicing is required when the apparatus has been damaged in any way, such as damaging a power supply cord or plug, spilling liquid or objects falling into the apparatus, exposing the apparatus to rain or moisture, operating abnormally, or dropping the apparatus.

# CameraMan Shot Director Components

The following information introduces you to each of the Shot Director components and their features.

## CameraMan Shot Director

The CameraMan Shot Director is a unique, multiple-camera control device combining pan/tilt, CCU, and autoTRACK (on autoTRACK-equipped models) control.



## Power and Connection Accessories

- 25' (7.6 m) CameraMan Communication Cable
- US Power Supply: 120 VAC, 60 Hz, 100 W Power Supply with attached cords  
or  
International Power Supply: 100-240 VAC, 50/60 Hz, 2.0A, 20VDC Power Supply

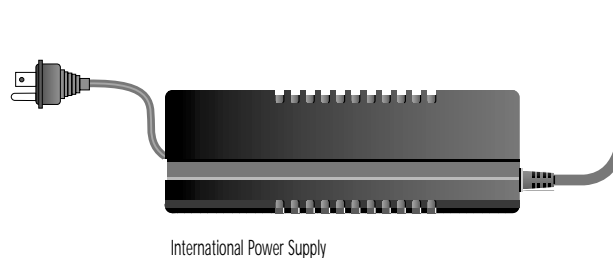
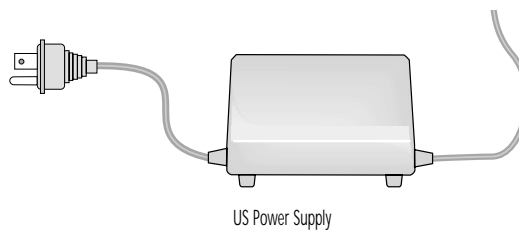
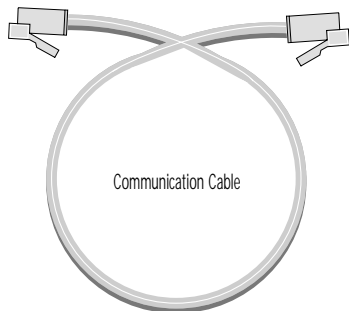

# Knobs, Buttons, and Slide Controls

Look at the top of your CameraMan Shot Director and you will notice that it is divided into four sections: the knobs (left), the buttons (lower-middle), the slide controls and joystick (right), and the LCD display (upper-middle).

## The Knobs

- ▼ **Focus Control** – Used manually to adjust the focal point of the lens.
- ▼ **Power Switch** – Turns the CameraMan Shot Director on and off. The power light is illuminated when power is ON.
- ▼ **Auto Iris** – When active, the CameraMan will adjust the camera's IRIS and GAIN automatically to maintain a constant video level. The AUTO IRIS light illuminates when it is active.
- ▼ **Manual Iris** – Used to manually adjust the camera's IRIS to brighten and darken the video picture.

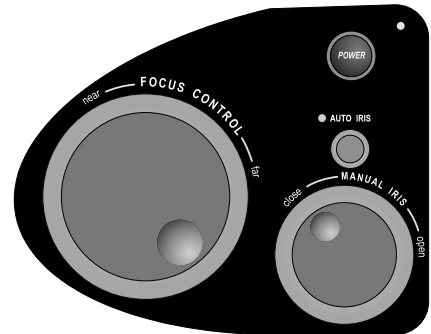

## The Buttons

- ▼ **Upper Section**– Used to navigate through the various LCD displays.
  - HOME– Displays the initial status menu
  - MENU– Displays menus allowing you change **Camera** settings.
  - SETUP– Displays menus allowing you to adjust **Camera and Shot Director** setup.
  - BACK– Displays the last menu you were viewing.

The four function command buttons on the top of this section correspond with function command fields on the LCD display.

- ▼ **Middle Section**– Used to store and recall the five preset autoTRACK Views: Left, Tight, Mid, Wide and Right (autoTRACK model only).
- ▼ **Lower Section**– Used to store and recall location presets, select between cameras in a multi-camera network, and enter and clear information found on the LCD display.

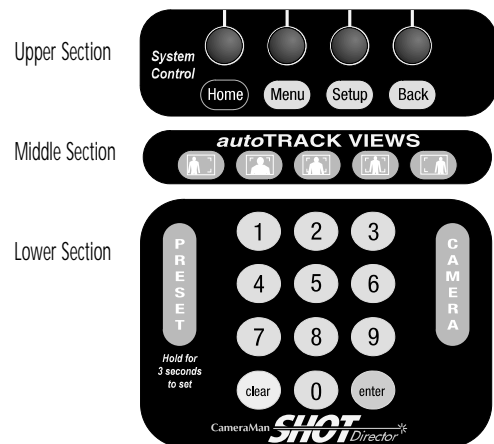

## The Slide Controls and Joystick

- ▼ **Speed Control Slides** – Used manually to adjust the maximum speed of the camera's pan and tilt motions and its zoom capabilities. When the slide control is adjusted to the down limit, the control is OFF. Zoom Speed Control is on the 3-CCD and 2112 cameras only.
- ▼ **Joystick (X-Y Control)** – Used manually to control the camera's pan/tilt motion. This control is speed proportional.
- ▼ **Joystick (Rotational Control)** – Used manually to zoom in (clockwise) for tighter views and to zoom out (counter-clockwise) for wider views. This control is speed proportional for the 2112 and 3-CCD cameras only.

*autoTRACK version only:*

- ▼ **autoTRACK button** – Used to activate and deactivate the autoTRACK capabilities to enable the camera to follow the presenter automatically.

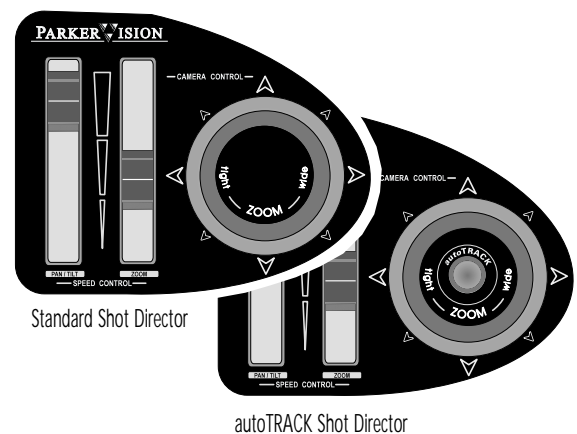



# LCD Display , Jacks And Ports

The knobs, buttons, and slide controls are used in conjunction with the display screen at the top of your CameraMan Shot Director. The jacks and ports on the back of your Shot Director are used to communicate with the CameraMan network.

## LCD Display Features

- ▼ **Camera # and Menu Title Field** – Numbers and words in this location identify the Camera Selected, and title for each menu display.
- ▼ **Function Command Fields** – items in these locations correspond to the function command buttons directly below them.

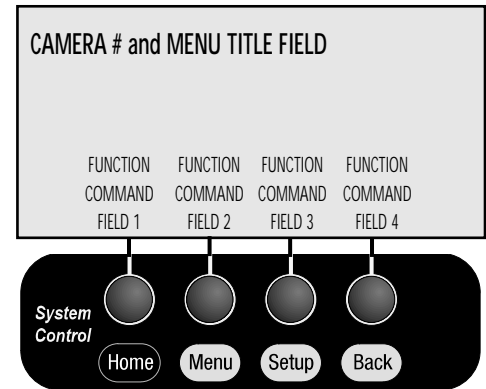

## Jacks and Ports



- ▼ **LCD Contrast Knob** - Used to increase and decrease the contrast on the Shot Director's LCD Display.

- ▼ **LCD Backlight Brightness Knob** - Used to increase and decrease the amount of light showing through the LCD Display.

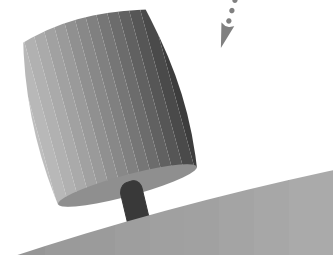

- ▼ **RS-485 Ports** – Used for communications with CameraMan cameras.
- ▼ **RS-232 Jack** – Used to update Shot Director software.
- ▼ **18-20 VDC** ===== Used to supply power to the Shot Director.

# Connecting To Your Network

Now that you are acquainted with your Shot Director's features, you can begin connecting it to your CameraMan network by following these steps:

1. Position the Shot Director on a flat surface. You should leave enough space around the unit so you can access all of the controls.
2. Using the CameraMan Power Supply, connect the DC Plug into the Shot Director port labeled 18-20 VDC and connect the other end into a standard wall outlet.
3. Connect the RS-485 port of the Shot Director to the RS-485 port of the CameraMan or Main Docking Station using the supplied cable. The RS-485 cable is a 4-conductor telephone cable wired straight through with RJ-type handset connectors.



Using any other wiring configuration may cause damage.



Multiple camera's require daisy-chain wiring (see diagram below).



For more information on multiple camera applications, refer to [General Pan/Tilt Camera Installation and Operations Manual](#).

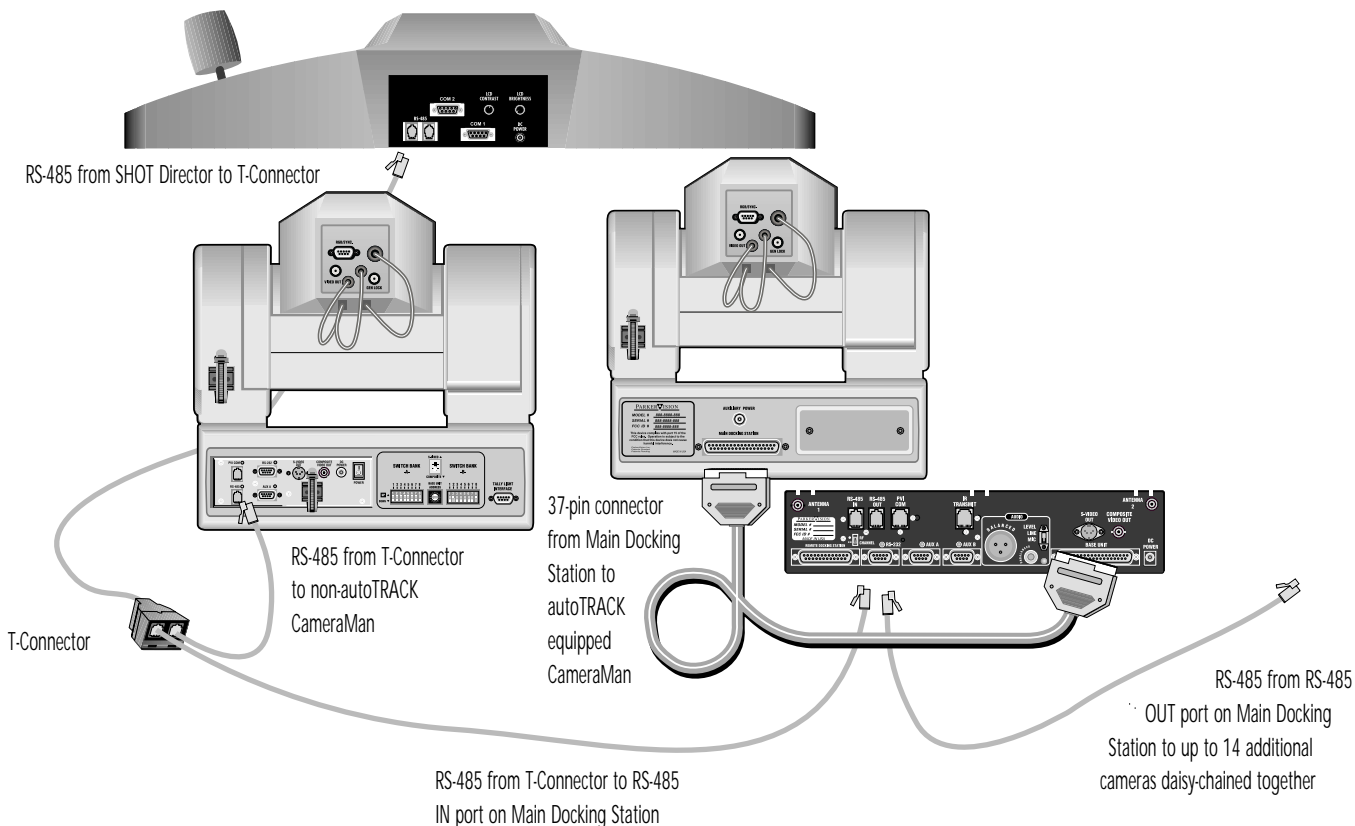
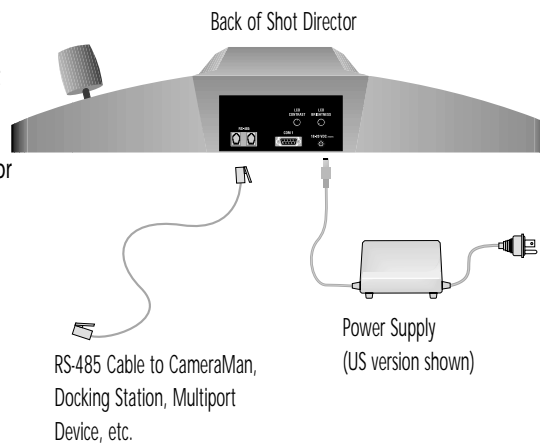

# Powering Up

To power up your CameraMan Shot Director and CameraMan network, power up the cameras and devices in your network, then press **POWER** on the Shot Director. The power light will illuminate and you will see the Startup Displays and HOME menus.

## Startup LCDs

### Startup Display 1

Indicates that the CameraMan Shot Director is zeroing the joystick automatically.

**Do not move the joystick during this procedure.**

- ! If manual calibration is needed (see troubleshooting section), press the **SETUP** button while the startup display is on. This will take you to startup display 2.

### Startup Display 2

- Rotate joystick several times in all directions as far as it will go, then twist the zoom back and forth several times to its maximum positions to calibrate the joystick.
- Press **Enter** when complete.

- 💡 If necessary, adjust the LCD CONTRAST and LCD BACKLIGHT on the rear panel of the Shot Director to obtain the best LCD clarity.

- 📖 For more information on powering up other devices in your CameraMan network, see the operations manuals that came with those devices.

## Home LCD Menus

Press **HOME** just below the display to access the HOME menus.

### Display Indicators

- **PAN**: Indicates horizontal plane rotation relative to the camera's 0 point (the arrow indicated on the bottom of the camera).
- **TILT**: Indicates the vertical plane rotation relative to horizontal (0.0 degrees).
- **ZOOM**: Indicates the value of zoom setting.
- **FOCUS**: Indicates the value of the focus setting (1-CCD cameras display **AUTO**)
- **CAMERA**: Indicates the active camera for Shot Director control (also shown in upper-left corner of LCD)
- **IRIS**: Indicates the value of the iris setting.
- **GAIN**: Indicates gain level as determined by the **GAIN** control and the **AUTO IRIS** control.

### Display Function Command Buttons

- **MAS PED**: (3-CCD) Selects the Master Pedestal Adjustment display screen.

- 💡 See page 22 for more information on Master Pedestal adjustments.

- **AUTO FOCUS** (1-CCD): Activates the camera's auto focus mode.
- **GAIN UP** or **DOWN**: Controls the brightness level of the video image. The current gain setting is indicated above the controls.
- **MORE**: Selects Home Menu Speed Display.

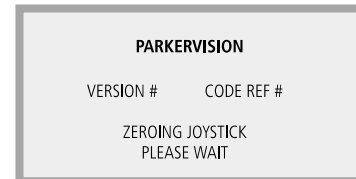

Startup Display 1

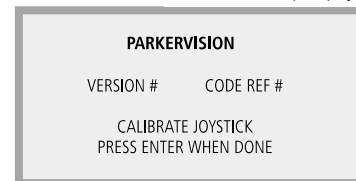

Startup Display 2

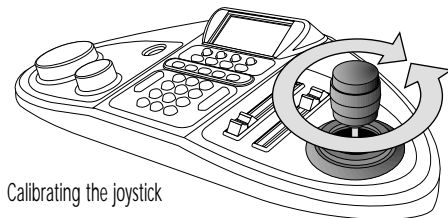

Calibrating the joystick

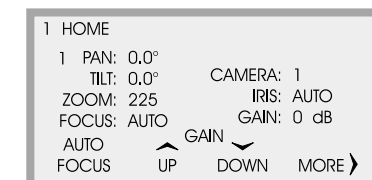
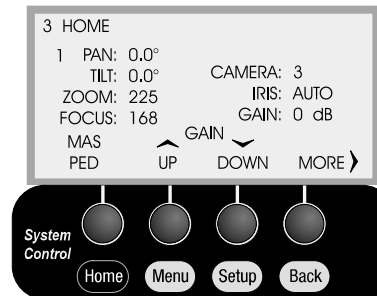

The 3-CCD version of the Home Indicator Menu (top) displays the MAS PED above the first function command button. The 1-CCD version (bottom) displays AUTO FOCUS.

# Powering Up

## Home Menu Speed Display

### Indicators

- MAX ZOOM SPEED: Speed indicator for the zoom speed control (3-CCD only).
- MAX PAN/TILT SPEED: Speed indicator for the pan/tilt speed control.

### Function Command Buttons

TOP: Selects Home Menu Indicator Display.

## Special Home LCD Menus

The looks of your Shot Director's Indicator Display can change to reflect whether various features are active or inactive. The autoTRACK and autoTRACK View Indicators are available only when using an autoTRACK-equipped Shot Director.

### Preset Home Menu

Indicates which Location Preset (if any) is active for the current camera.

### autoTRACK Home Menu

Indicates if the Shot Director is currently in autoTRACK mode.

### autoTRACK View Home Menus

Shows an autoTRACK View icon when autoTRACK is turned on and when using an autoTRACK View.

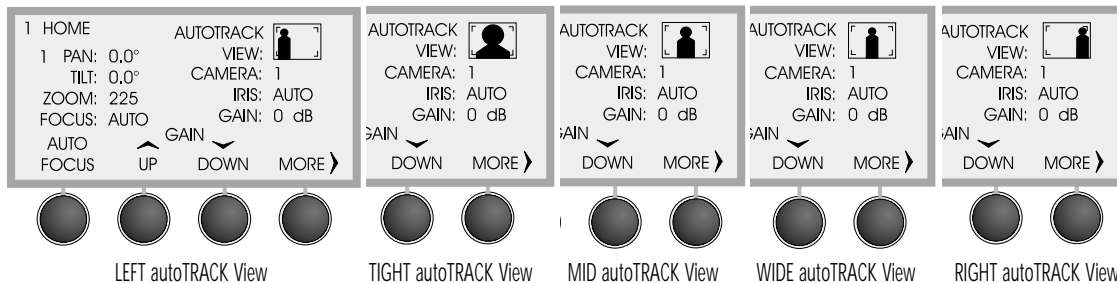
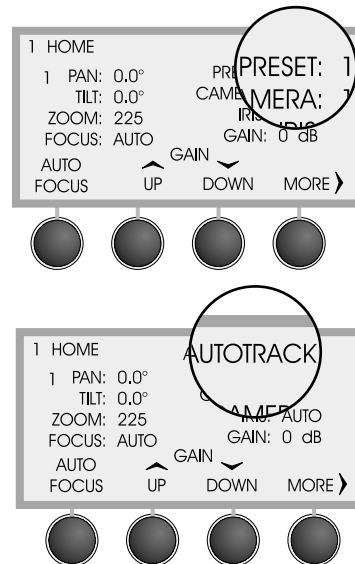
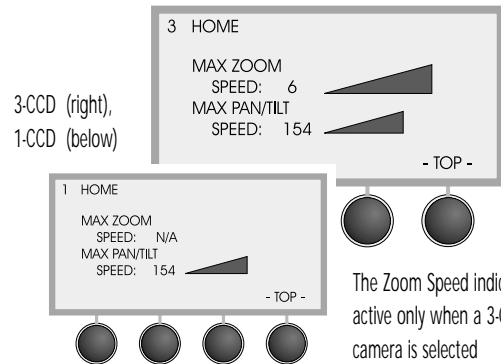

# CameraMan and Shot Director Setup

Now that you've powered up your system, you can begin setting up the Shot Director to work with the cameras in your system. The **SETUP** menus enable you to configure both the Shot Director and each camera in your network.

## Setting Up Multiple-Camera Systems

1. Set the **BASE UNIT ADDRESS** on the each camera in your network. The CameraMan Shot Director automatically numbers the CameraMan cameras in your network from 1 to 16. These numbers correspond to addresses 0-F on the CameraMan base unit. Therefore, set the base unit address of the cameras as follows:

Camera Number:	1	2	3	4	5	6	7	8	9	10	11	12	13	14	15	16
Camera Base Unit Address:	0	1	2	3	4	5	6	7	8	9	A	B	C	D	E	F



For details on changing your CameraMan camera's base unit address, see your *CameraMan System Installation and Operations Manual*.

2. Use the keypad to select a camera to configure.
  - Press the number of the camera you wish to configure (note the LCD displays the camera selection screen).
  - Press **CAMERA** (note the LCD verifies the camera selected).
  - Verify that the **HOME** menu indicates your selected camera.
3. Repeat steps 1-2 to set up each camera using the **SETUP** menus.



Enter the camera number, then press **CAMERA**.



Note the camera selection and verification screens, and the camera number shows on the indicator screen.

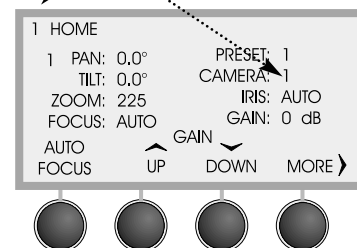

## Setup LCD Menu

The initial Setup menu appears when you press **SETUP**.

**Camera:** Used to access the Setup Camera menus.

**Shot Dir:** Used to access the Setup Director menus.

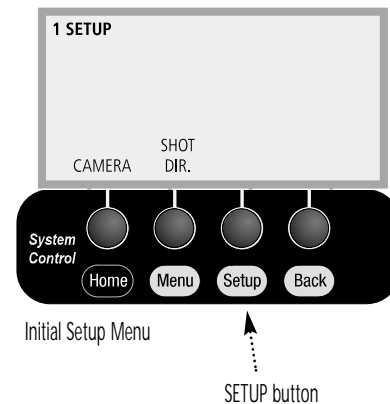

# CameraMan Setup

## Setup Camera Menu

Display Path: **SETUP > CAMERA**

The Camera Setup LCD menus enable you to adjust various camera parameters. The Camera Default setup feature (**CAMERA DFLTS**) is not available when working with 1-CCD cameras (except the 2112).

3-CCD/1-CCD

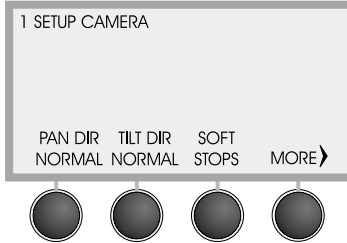

3-CCD/2112

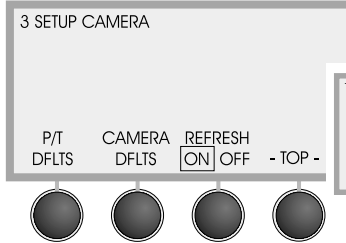

Setup Camera menus: The Camera Default settings are not available for 1-CCD cameras (below).

1-CCD

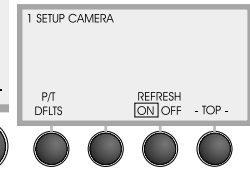

### Pan Dir [Normal/Reverse]:

Used to re-orient the camera's pan direction relative to Shot Director movement. Default is **NORMAL**.

#### Understanding the PAN Motion

- In **NORMAL** mode, the camera's PAN motion is designed to operate as if you are behind the CameraMan, looking at your subject. In this mode, the camera pans in the direction that you move the joystick.
- The **REVERSE** mode is designed to enable you to operate a camera that may be facing toward you. In this mode, the camera pans in the opposite direction that you move the joystick.

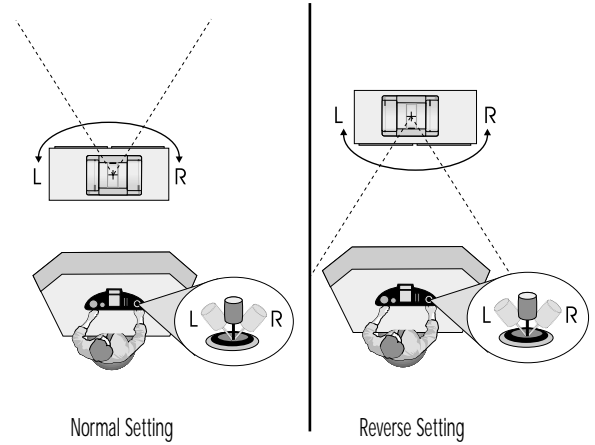

### Tilt Dir [Normal/Reverse]:

Used to re-orient the camera's tilt direction relative to Shot Director movement. Default is **NORMAL**.

#### Understanding the TILT Motion

While the orientation of **PAN** motion is based more on your application need and the orientation of the controller to the camera, the **TILT** orientation is based more on the controller's preference.

- In **NORMAL** mode, the joystick's movement corresponds to the camera's motion. Pushing forward on the joystick makes the camera tilt up.
- In **REVERSE** mode, moving the joystick's movement is opposite the camera's motion. Pushing forward on the joystick makes the camera tilt down.

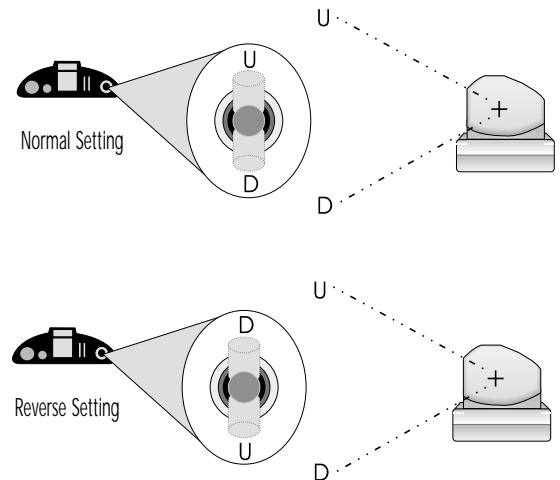

Try each of these settings to see which is best for your application, and with which you are most comfortable.



Each CameraMan in your system communicates independently with the Shot Director, so you can change each camera's setup settings (including pan and tilt orientation).

# CameraMan Setup

## Soft Stops Menu:

Display Path: **SETUP > CAMERA > SOFT STOPS**

The Soft Stops menu enables you to set the pan and tilt limits for the camera.

### Indicators:

- The numbers in the center of the screen are the camera's current position relative to the zero point (straight ahead with 0° tilt).
- The second row of numbers indicate the current limits.

### Function Control Buttons:

1. Using the joystick, pan the camera to it's left and stop it where you want to set the soft stop.
  2. Press and hold the **LEFT** function control button until you hear a beep (Note: A confirmation window appears with **\*CAMERA DATA SAVED\***).
  3. Repeat steps 1-2 for the **RIGHT**, **UP**, and **DOWN** soft stops.
  4. If you need to change a soft stop, press **CLEAR** on the keypad and the stop you want to change. This erases that soft stop, enabling you to reset it using steps 1-2.
- **Range:** LEFT: -180° / RIGHT: +180° / UP: +25° / DOWN: -25°

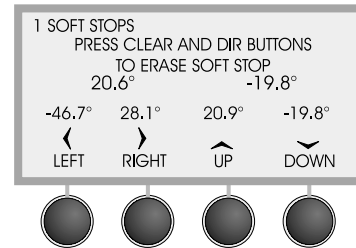

Soft Stops Menu

## Pan/Tilt Default Menu:

Display Path: **SETUP > CAMERA > P/T DFLTS**

To restore the camera's Pan/Tilt orientation, location presets, soft stops, and factory preset autoTRACK Views:

1. Press **DEFAULT**.
2. Press **YES** to perform or **NO** to cancel the system reset (Note: A confirmation window appears with **\*CAMERA DATA SAVED\***).

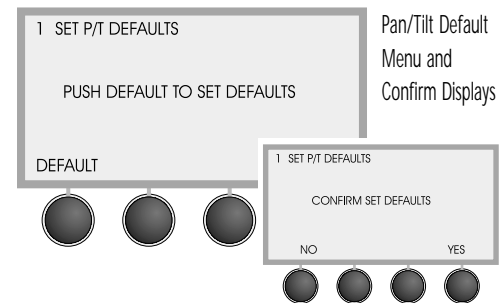

Pan/Tilt Default Menu and Confirm Displays

## Camera Default Menu (3-CCD and 2112):

Display Path: **SETUP > CAMERA > CAMERA DFLTS**

To restore a 3-CCD or 2112 camera's factory CCU settings:

1. Press **DEFAULT**.
2. Press **YES** to perform or **NO** to cancel the system reset (Note: A confirmation window appears with **\*DIRECTOR DATA SAVED\***).



See Appendix D for system default details.

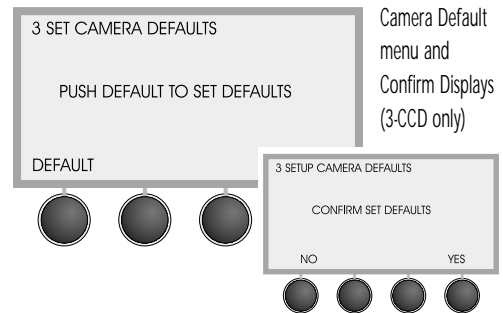

Camera Default menu and Confirm Displays (3-CCD only)

## Refresh ON/OFF:

Display Path: **SETUP > CAMERA**

Shot Director is designed to work with CameraMan cameras, so this setting defaults to **Y** (YES). If your application does not use CameraMan cameras, press the function control button so the box surrounds **N** (No).

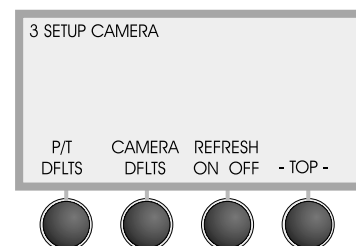

Press **TOP** to return to the first Setup Camera Display.

# Shot Director Setup

## Setup Director Menu

Display Path: *SETUP > SHOT DIR*

### Address Menu:

Display Path: *SETUP > SHOT DIR > ADDRESS*

The Shot Director requires a unique address. To set the address, key in the address number on the numeric keypad, then press Enter.

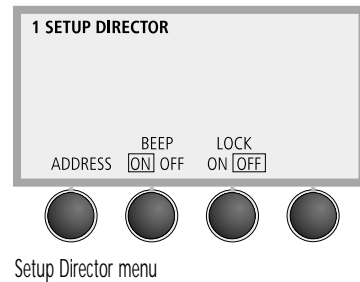
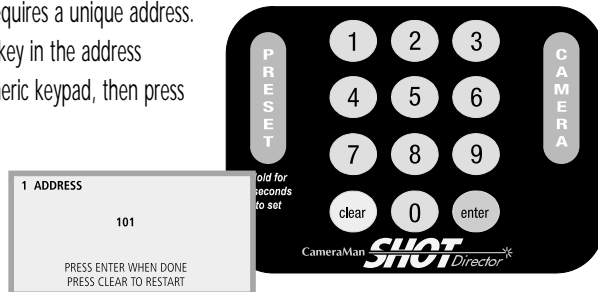

Setup Director menu

- ! The Default address should work in most applications.
- ! If the address is invalid or the Shot Director is locked (right), a notification screen displays.



### Beep Setting:

Display Path: *SETUP > SHOT DIR*

Press the function command button to turn the audible beep on or off. The beep occurs when location presets or autoTRACK views are being stored. Default is **ON**.

### Lock Setting:

Display Path: *SETUP > SHOT DIR*

Press the function command button to prevent setup changes and preset storage. Makes the Shot Director *read-only*. Default is **OFF**.



# Using the Controls

Now you are ready to begin using the CameraMan Shot Director to maneuver your CameraMan cameras. The next few pages explain how to use the knobs, buttons, slides, and menus to give you the ultimate in camera control.

## Left-Side Controls

### Power Button

- Press **POWER** to turn the Shot Director on/off.
- The red LED light illuminates when the power is ON.

### Focus Control

- Turn clockwise to focus far (send the focal point farther from the camera).
- Turn counter-clockwise to focus near (bring the focal point closer to the camera).
- Range: 0 (near) – 255 (far).

### Manual Iris

- Turn clockwise to brighten the picture.
- Turn counter-clockwise to darken the picture.
- Range: 1 (closed)–31 for 3-CCD cameras, 0 (closed)–16 for 1-CCD cameras.

### Auto Iris

- Press **AUTO IRIS** to turn Auto Iris ON.
- The red light illuminates when the Auto Iris is ON.



Any movement of the Manual Iris Control, or change of the Manual Gain, turns the Auto Iris OFF.

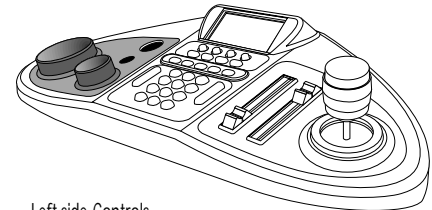

Left-side Controls

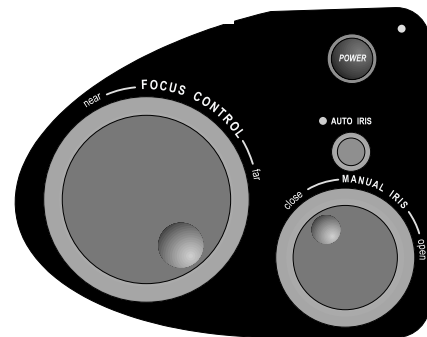

## Right-Side Controls

### Pan/Tilt Speed Slide Control

- Slide UP to increase and DOWN to decrease the maximum pan/tilt velocity of the camera.
- Range: 0 (off) – 252.

### Zoom Speed Slide Control (3-CCD and 2112)

- Slide UP to increase, and DOWN to decrease the maximum zoom velocity of the camera.
- Range: 0 (off)–12.

### CameraMan Joystick Controller

- Camera Control: See page 9 for information on setting the directional controls.
- Zoom Control:
  - Turn the outer ring clockwise to zoom in (tight).
  - Turn the outer ring counter-clockwise to zoom out (wide).

(autoTRACK-equipped models only)

- autoTRACK Button: Press autoTRACK to turn the camera's autoTRACK mode ON and OFF.



The autoTRACK button defaults to a center-referenced window with 0° PAN, 0° TILT, and an offset Subject Position of 0°. See page 17 for more information.

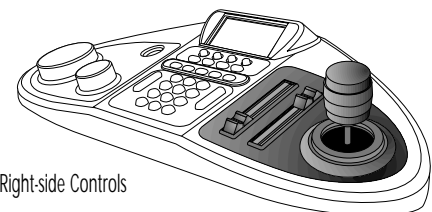

Right-side Controls

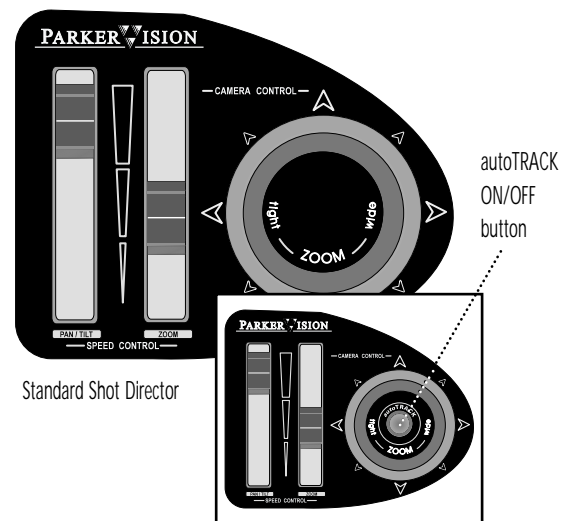

Standard Shot Director

autoTRACK Shot Director

# Using the Controls

## Middle Controls

### System Control Buttons

- Press **HOME** to select the HOME display menu.
- Press **MENU** to select the MENU display menus.
- Press **SETUP** to select the SETUP display menus.
- Press **BACK** to view the previous display menu.
- The four function command buttons correspond to information you see on the LCD.



Middle Controls

### autoTRACK Views (on autoTRACK-equipped models only)

Used to position the presenter in the frame of the autoTRACK View. Five preset views are pre-programmed, but can be changed: Left, Tight, Mid, Wide, and Right. To change one of the pre-programmed autoTRACK Views, follow the procedures on page 16. You also can store and recall an additional ten (10) custom autoTRACK Views by following the procedures on page 20.

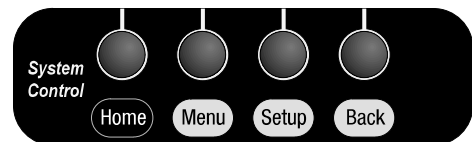

System Control Panel

### Numeric Keypad

Used to store and recall location presets (next page) and to select the camera to be controlled (below). The **CLEAR** and **ENTER** buttons are used in certain menu operations.

#### To select a camera to control:

1. Press the number of the desired camera.
2. Press **CAMERA**.



autoTRACK Panel or ParkerVision logo on

non-autoTRACK Shot Directors



Numeric Keypad Panel

# Controlling The Camera's Movement

Location Presets, autoTRACK, and autoTRACK Views are several Shot Director features which provide automated control over the camera's movement. This section explains how to use these features.

## Location Presets

Location Presets enable you to position and adjust the view quickly of any camera on the network. Using the Shot Director's numeric keypad and camera control features, you can store and recall pan/tilt position, zoom perspective, iris, and focus setting (3-CCD) for each Location Preset.

### To store a Location Preset:

1. Select the desired camera (if it is not already selected).
2. Adjust the camera for the desired Pan, Tilt, Zoom, Focus, Gain, and Iris settings.
3. Key in the number of the preset location desired.
4. Press and hold **PRESET** for 3 seconds (you will hear one beep).
5. Release **PRESET** (Note: the LCD displays **\*CAMERA DATA SAVED\***).

### To recall a location preset:

1. Select the desired camera.
2. Key in the number of the desired preset.
3. Press and release **PRESET**.



The **Invalid Entry** message appears if you enter a camera number over 16 or a location preset over 99 on 1-CCD models/125 on 3-CCD models.

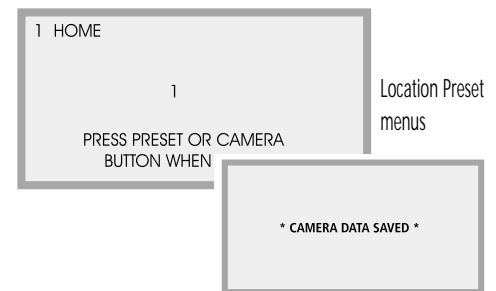

## Menu LCD Menus

The initial **Menu** display appears when you press **MENU**. These menus enable you to control each camera's movement and video. The initial display changes depending on whether you are accessing a 1-CCD or 3-CCD/2112 camera.

### Movement Controls (1-CCD and 3-CCD cameras):

- **PRESET SPEED**: Displays the menu used to adjust the preset speed.
- **AUTO TRACK**: Gives you access to the autoTRACK menus (on autoTRACK models only).



The Video Controls (**CAMERA ADJUST**) are explained on pages 20-26.

Movement Controls on the Initial Menu Display

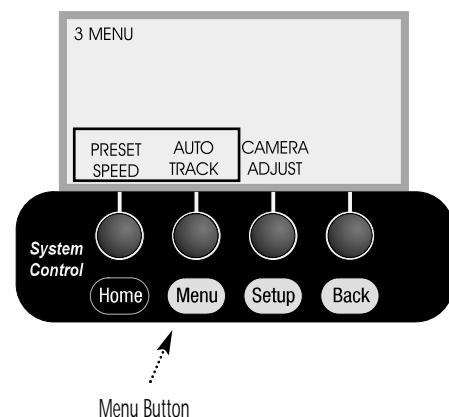

# Controlling The Camera's Movement

## Preset Speed LCD

Display Path: MENU > PRESET SPEED

- The Preset Speed menu enables you to set the maximum speed at which the camera moves from one Location Preset to another. Press the **UP** and **DOWN** function command buttons to increase and decrease the speed.
- Range: 10-100, in steps of 10 (10 = slowest).

**!** Changing the preset speed affects the camera's operation with the Personal Locator, Camera Control, and Tracking System Keypads. Return the setting to 100 for normal operations with these keypads.

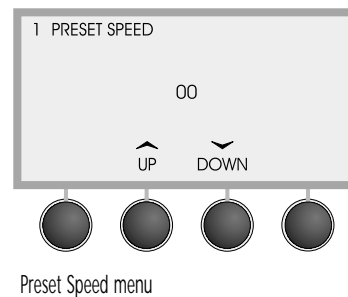

## Using autoTRACK

autoTRACK-equipped Shot Directors enable you to use CameraMan's patented autoTRACK technology, so the camera will follow a subject around the room automatically.

**!** Pages 16-19 refer to the autoTRACK functionality of your Shot Director. If your Shot Director is not autoTRACK-equipped, you can skip to page 20.

**!** For detailed information on autoTRACK, please refer to your *Presenter* or *Deluxe Camera System Installations and Operation Manual*.

### Before entering autoTRACK mode:

1. Ensure that the Main Docking Station is properly installed, and that your subject is wearing the Tracking Ring.
2. Turn the Tracking Ring Power Pack ON.

### Entering autoTRACK mode:

There are two ways to enter autoTRACK:

1. autoTRACK View buttons - put the camera into autoTRACK mode, recalling a view with preset zoom, focus, iris, window, subject position, and sensitivity settings.
2. autoTRACK button on top of the joystick - puts the camera into autoTRACK mode without changing the current zoom perspective.

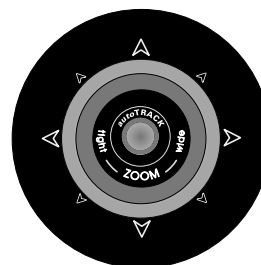
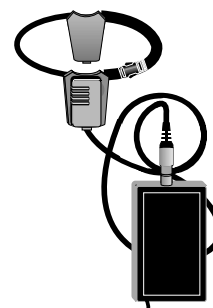

To enter autoTRACK mode, press the button on top of the joystick controller (left) or one of the autoTRACK Views (below).



# Controlling The Camera's Movement

## autoTRACK Views

If you have an autoTRACK-equipped CameraMan Shot Director, it is capable of storing and recalling up to 15 autoTRACK Views. Five basic preset views – left, tight, mid, wide, and right – are programmed into the Shot Director already. You can adjust these or create new Custom Views (see page 19).

The five basic preset views enable you to change from a close head shot with the **TIGHT** autoTRACK View button to emphasize facial expressions, then switch to a full-body shot by pressing the **WIDE** autoTRACK View button. Presenters also can share the video screen with a flipchart or other key presentation areas with the **LEFT** or **RIGHT** autoTRACK View buttons. The **MID** autoTRACK View gives you a medium-range shot.

Each autoTRACK View stores and recalls changes in Window, Sensitivity, Subject Position, Zoom, Focus, and Iris. This enables you to customize each autoTRACK View to suit your needs.

To store an adjusted view in one of the five basic autoTRACK Views buttons:

1. Press the autoTRACK View button that you want to change.
2. Adjust the zoom, focus, gain, and iris to the desired new positions.
3. Adjust your Window, Subject position, and Sensitivity levels (if needed).
4. Press and hold the same autoTRACK view button for 3 seconds (you will hear one beep).
5. Release the button.



After changing an autoTRACK View, the LCD displays a confirmation of **\*Camera Data Saved\***.

\* CAMERA DATA SAVED \*

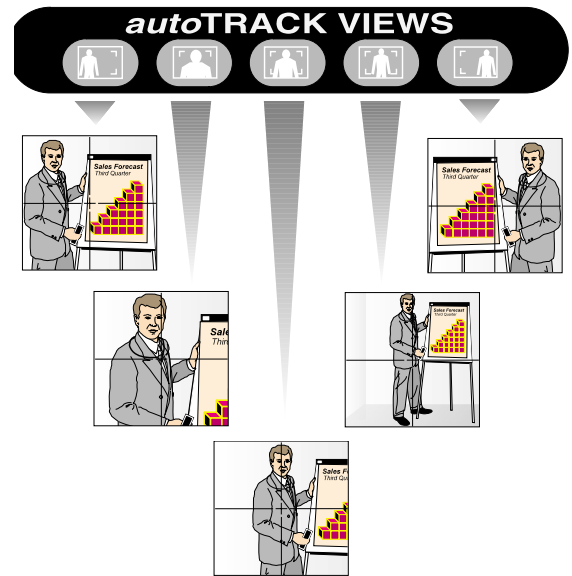

Example of the five preset autoTRACK Views

To recall one of the five basic autoTRACK Views:

1. Press and release the autoTRACK View button that you want to change. The camera automatically switches to that view and engages autoTRACK.
2. Look at the display, which should now show an icon representing the autoTRACK view you're currently using.



To deactivate autoTRACK, press **autoTRACK** on top of the joystick or recall a location preset.



Once you are in autoTRACK mode, the pan/tilt functions of the joystick are disabled. You must press **autoTRACK** on top of the joystick to deactivate autoTRACK and return pan/tilt functionality to the joystick.

# Controlling The Camera's Movement

## Tracking Adjustments

### Terms and Definitions:

- An **autoTRACK Window** is an invisible area in which your subject can move without the camera following. If the person moves outside this defined area, the camera begins to follow them again. This window is measured by the number of degrees of **PAN** and **TILT** from the center of the window.
- The **Window Reference** is based on the center of your Pan/Tilt Window. It can be referenced to either the center of the screen – *Center Reference*, or the person wearing the Tracking Ring Sensor – *Sensor Reference*.
- The **Subject Position** refers to the Subject's location as it appears on the screen. This is measured by the distance from the center of the screen. When the Subject moves outside the Pan/Tilt Window, the camera resumes tracking them at the Subject Position offset.
- The **Screen** is the visible area on the monitor.

**!** If your presenter can walk off the screen before the camera begins following, you may need to change the size of your Window or decrease the offset of the Subject Position (see Figure 4).

**!** Zooming in and out impacts your Subject Position. Zooming in causes the Subject to move toward the outer edge of the screen. Zooming out causes the Subject to move toward the center of the screen.

### Tips to Adjusting the Parameters

While in autoTRACK mode, the pan and tilt capabilities of the joystick are disabled, but you can continue to zoom in and out. The following tips can help you keep your subject from moving off the screen while zooming in and out in autoTRACK mode.

1. Determine the physical area (presentation space) you need your camera to cover.
2. Ask your subject to wear the Tracking Ring Package, power it up, and stand within the presentation space at the point closest to the camera.
3. Press the autoTRACK button on top of the joystick to enable the camera's autoTRACK functionality.
4. Zoom in on your subject.
5. Make your adjustments to the Window, Window Reference, and Subject Position, then focus.
6. Ask your subject to walk around within the presentation area.
7. While the camera follows the subject automatically, zoom in and out to ensure that he/she remains on-screen.

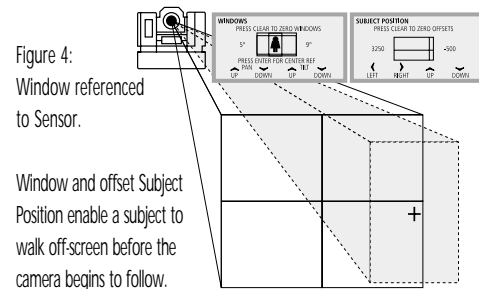
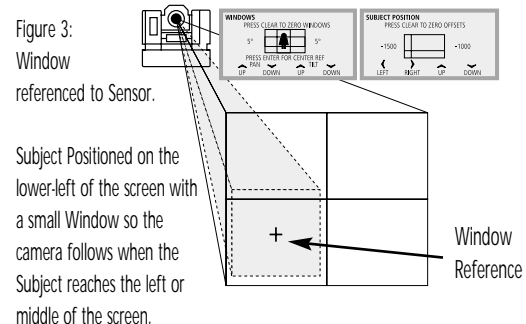
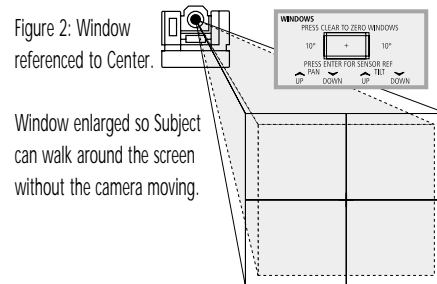
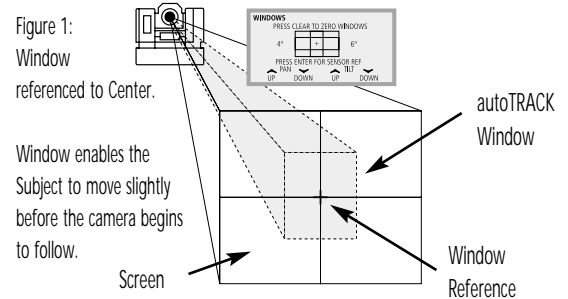

# Controlling The Camera's Movement

## autoTRACK LCD Menus

The autoTRACK menus enable you to fine-tune your Subject's position on-screen while the camera is in Tracking mode.

### Main autoTRACK Menu

Display Path: **MENU > AUTO TRACK**

- **WINDOW:** Selects the menu used to adjust the autoTRACK Window size.
- **SUBJECT POSITION:** Selects the menu used to adjust the Subject Position.
- **SENSITIVITY:** Selects the menu used to adjust the tracking Sensitivity.
- **CUSTOM VIEWS:** Used to store and recall 10 additional autoTRACK Views.



If your Shot Director is not in autoTRACK mode, a **Tracking is off** message displays.

### autoTRACK Windows Menu

Display Path: **MENU > AUTOTRACK > WINDOW**

The Window adjustment sets the size of the window that autoTRACK uses to follow the presenter. A small window tracks the presenter's every move, while a larger window enables the presenter to move a greater distance before the camera reacts to the movement. The Shot Director defaults to the *Sensor Reference*.

#### Sensor Reference

A Window with a sensor reference (depicted by the person figure in the box) uses the Tracking Ring Sensor as a reference point.

#### Center Reference

A Window with a centered reference (depicted by a + in the box) uses the center of the screen as a reference point.

#### Making Adjustments

- **PAN UP/DOWN:** Adjusts the horizontal size of the window. Range: 0-12 degrees.
- **TILT UP/DOWN:** Adjusts the vertical size of the window. Range: 0-12 degrees.
- **Clear:** Resets the window size to zero.
- **Enter:** Toggles between Center and Sensor Reference displays.
- **Default:** 0° PAN, 0° TILT.

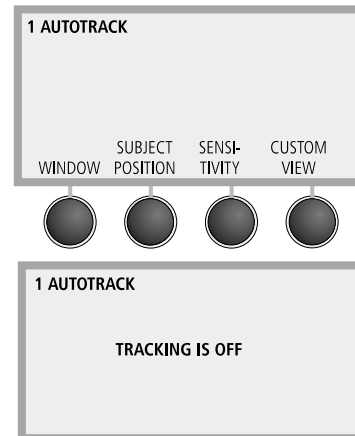

autoTRACK display when autoTRACK is ON (top) and when autoTRACK is OFF (bottom).

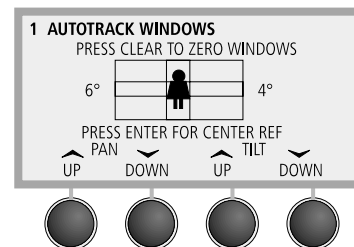

Sensor Referenced autoTRACK Window (above)

Center Referenced autoTRACK Window Menu (below).

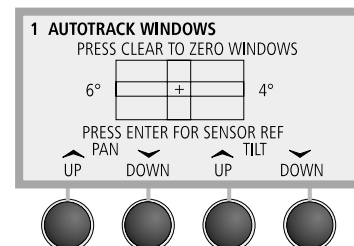

# Controlling The Camera's Movement

## *Subject Position Menu*      *Display Path: MENU > AUTOTRACK > SUBJECT POSITION*

This menu enables you to offset the Centered or Sensor Reference relative to the center of the picture. The entire window can be shifted up or down and left or right.

- **Up, Down, Left, Right** Function Command Buttons: Move the tracking window in the respective direction.
- **PAN Range:** +/- 4600 (approximately +/- 20°).
- **TILT Range:** +/- 2300 (approximately +/- 10°).
- You also can use the Shot Director joystick to make these adjustments.

 Use caution when adjusting Pan/Tilt windows and Subject Position. It is possible to adjust the windows so that the presenter is off the screen.

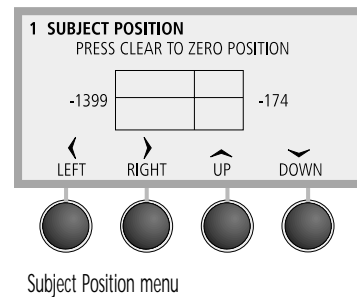

## *Sensitivity Menu*      *Display Path: MENU > AUTOTRACK > SENSITIVITY*

Used to adjust the speed at which the CameraMan returns the presenter to the Subject Position setting.

- **Up/Down Keys:** Adjust sensitivity up or down.
- **Range:** 10-120, in steps of 10 (10 = slow).

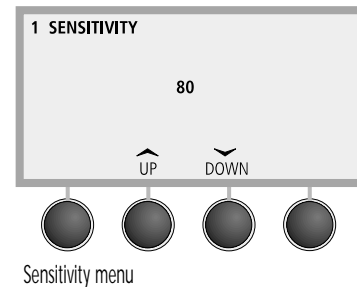

## *Custom Views Menu*      *Display Path: MENU > AUTOTRACK > CUSTOM VIEW*

Used to store or recall up to 10 autoTRACK views. These are separate from, and in addition to, the autoTRACK Views stored in the buttons above the numeric keypad.

### To store an additional Custom View:

1. Adjust zoom, focus, Iris, window, subject position and sensitivity to the desired positions or settings.
2. Access the Custom Views Menu.
3. Enter the number (1-10) of the Custom View to be stored.
4. Press and hold **Recall/Store** for 3 seconds. You will hear one beep.
5. Release the button (A confirmation displays **\*CAMERA DATA SAVED\***).

### To recall a Custom autoTRACK View:

1. Verify that the Tracking Ring Package is turned ON.
2. Open the **Custom Views** menu.
3. Select the number of the desired Custom View.
4. Press and release **Recall/Store**.

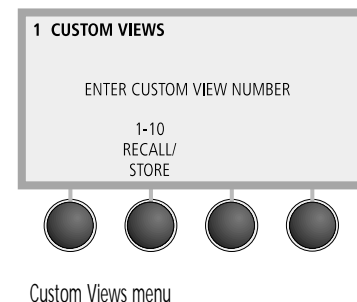



# Controlling The Camera's Video

Your Shot Director's CCU functionality gives you the ability to fine-tune each 3-CCD camera's video. All of the following CCU adjustments are stored in the Shot Director. If a 3-CCD camera is powered on, then you can use the Shot Director to select that camera. This will download that camera's settings and enable you to make adjustments.

## Menu LCD Menus

The initial **Menu** display appears when you press **MENU**. These menus enable you to control each camera's movement and video. The initial display changes depending on whether you are accessing a 1-CCD or 3-CCD/2112 camera.

### Video Controls (for 3-CCD cameras only):

- **CAMERA ADJUST**: Provides access to the camera menus (i.e., Gain, Paint, White Balance) and enables you to change the settings while using the Shot Director.



The Movement Controls (**PRESET SPEED** and **AUTO TRACK**) are covered on pages 15-19.

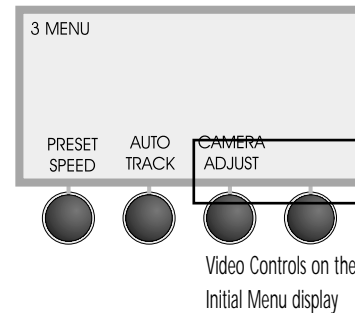

## Camera Adjust LCD Menus

*Display Path: MENU > CAMERA ADJUST*

- **DETAIL**: Selects the **Detail Control** menu.
- **KNEE**: Used to adjust the **Knee**.
- **WHITE BALANCE**: Selects the **White Balance** control menus.
- **MORE**: Selects **Camera Adjust menu 2**.

*Display Path: MENU > CAMERA ADJUST (2112 Camera)*

- **GEN LOCK**: Turns the **GEN LOCK** function **ON** or **OFF**.
- **HORZ PHASE**: Displays the **H-Phase** Menu.
- **SC FINE**: Displays the **SC-Phase** Menu.
- **SHUTTER**: Displays the **Shutter** Menu for the 2112 Camera.

*Display Path: MENU > CAMERA ADJUST > MORE*

- **AE WIN**: Used to select the size of the **Automatic Exposure Window**.
- **FLD/FRM**: Used to select between **Field** or **Frame**.
- **SHUTTER**: Selects the **Shutter Control** menus.
- **MORE**: Selects **Camera Adjust menu 3**.

*Display Path: MENU > CAMERA ADJUST > MORE > MORE*

- **LIN MAT**: Used to turn the **Linear Matrix** on and off.
- **C. TEMP**: Used to select the **Color Temperature**.
- **GAMMA**: Used to turn the **Gamma** on and off.
- **MORE**: Selects **Camera Adjust menu 4**.

*Display Path: MENU > CAMERA ADJUST > MORE > MORE > MORE*

- **G. SYNC**: Used to turn the the **G Sync** on and off.
- **D-SUB**: Used to configure the **DB-9** video out.
- **SHADE**: Selects the **Shade Control** menus.
- **MORE**: Selects **Camera Adjust menu 5**.

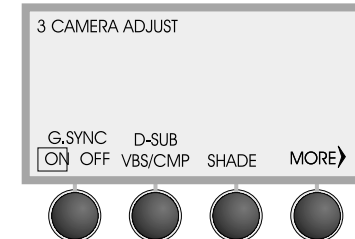
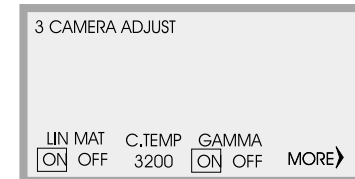
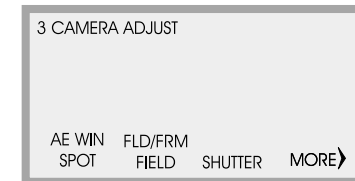
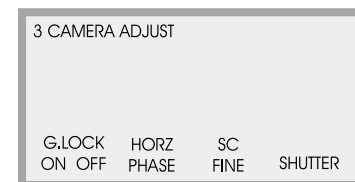
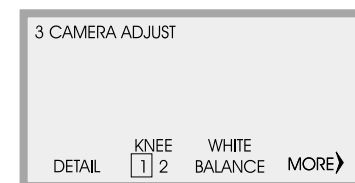

# Controlling The Camera's Video

Display Path: **MENU > CAMERA ADJUST > MORE > MORE > MORE > MORE**

- **H PHASE:** Selects the **Horizontal Phase Control** menus.
- **SC FINE:** Selects the **Sub-Carrier Phase Fine Adjustment Control** menus.
- **TOP:** Returns to **Camera Adjust menu 1**.

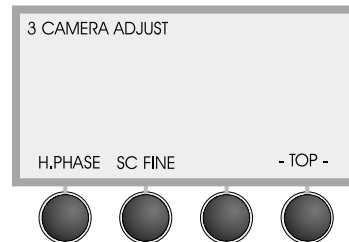

Camera Adjust menu 5

## Detail Menu

Display Path: **MENU > CAMERA ADJUST > DETAIL**

Increases and decreases the level of sharpness in the picture.

- **UP:** makes picture sharper.
- **DOWN:** makes picture softer.
- **Range:** -99 to +99.

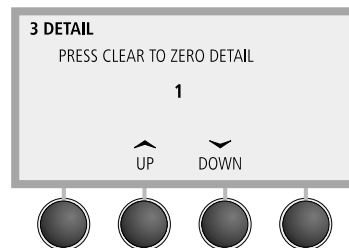

Detail menu

## Knee Setting

Display Path: **MENU > CAMERA ADJUST**

Selects the knee value (amount of peak white compression) for the camera.

- Select **1** for use in normal lighting.
- Select **2** to shoot a bright object in a dark scene.

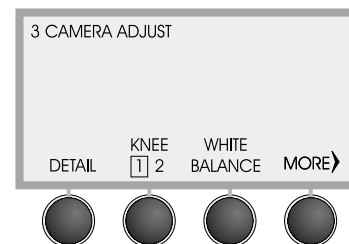

Knee Setting on Camera Adjust menu

## White Balance Menu

Display Path: **MENU > CAMERA ADJUST > WHITE BALANCE**

- **AUTO:** Used to set the camera's **White Balance** automatically in a fixed lighting condition. This must be reset if the lighting changes.
- **ATW:** Used to activate **Auto Trace White**, which continually changes the camera's **White Balance** as light temperatures change.
- **MANUAL:** Used to adjust the camera's **White Balance** manually.
- Press **MORE** to:
  1. Display the **Red/Blue Paint** menu when **AUTO** or **ATW** is selected.
  2. Display the **Red/Blue Gain** menu when **MANUAL** is selected.

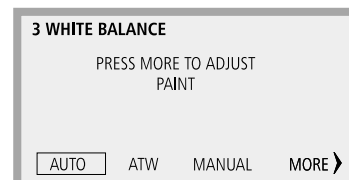

- Pressing **MORE** while in **AUTO** and **ATW** **White Balance** enables you to adjust the **Red/Blue Paint**.



- **MANUAL** **White Balance** enables you to adjust the **Red/Blue Gain**.

# Controlling The Camera's Video

## Red/Blue Paint Menu

(available in AWB and ATW)

Display Path: **MENU > CAMERA ADJUST > WHITE BALANCE > AUTO or ATW > MORE**

Increases and decreases the red and blue levels in the video image to compensate for inadequate lighting or the subject's color characteristics.

- **RED UP or DOWN:** Used to adjust the Red Paint.
- **BLUE UP or DOWN:** Used to adjust the Blue Paint.
- **Range:** -7 to +7.
- **Clear:** Sets both Paint settings to zero.
- **Enter:** Toggles between Paint and Master Pedestal menus (see below).

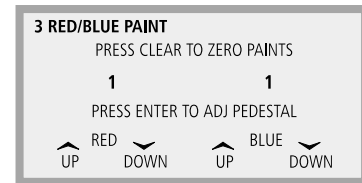

Paint menu

## Red/Blue Gain Menu

(available only in Manual WB)

Display Path: **MENU > CAMERA ADJUST > WHITE BALANCE > MANUAL > MORE**

Increases and decreases the red and blue levels in the brightest area of the video image.

- **RED UP or DOWN:** Used to adjust the Red Gain.
- **BLUE UP or DOWN:** Used to adjust the Blue Gain.
- **Range:** -99 to +99.
- **Clear:** Sets both Gain settings to zero.
- **Enter:** Toggles between Gain and Master Pedestal menus (see below).

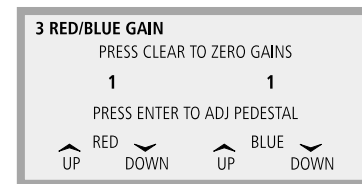

Gain menu

## Master Pedestal Menu

Display Path 1: **MENU > CAMERA ADJUST > WHITE BALANCE > MORE > ENTER**

Display Path 2: **HOME > MAS PED**

Lightens and Darkens the level of the black component of the video picture.

- **UP:** Lightens the black component level and decrease the overall picture contrast.
- **DOWN:** Darkens the black component level and increase the overall picture contrast.
- **Range:** -99 to +99.
- **P1 or P2:** Recalls pedestal presets for the selected camera.

### To store pedestal presets:

1. Adjust the Master pedestal using the **Up/Down**.
2. Press and hold **P1** or **P2** for 3 seconds (a beep will sound).
3. Release the preset key (A confirmation displays **\*DIRECTOR DATA SAVED\***).

### To recall a preset:

1. Press and release the desired preset button.

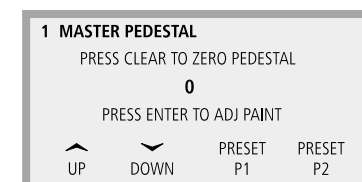

Master Pedestal/Paint menu

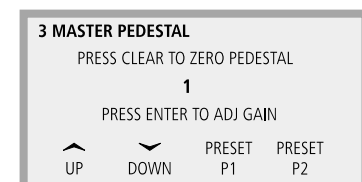

Master Pedestal/Gain menu

Red/Blue Paint or Gain, and Master Pedestal information are stored in Presets.

# Controlling The Camera's Video

## AE Win Setting

Display Path: MENU > CAMERA ADJUST > MORE

The size of the **Automatic Exposure Window** dictates how much of the video frame is used in determining the **AGC**, **CCD-Iris**, and **AUTO IRIS** settings. Default: **LARGE**.



Large Window

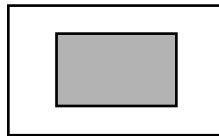

Medium Window

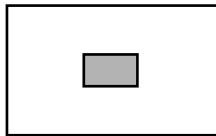

Spot Window

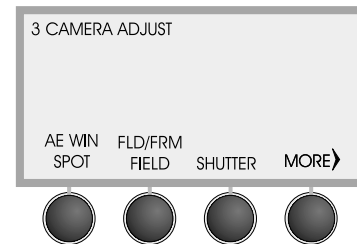

Camera Adjust menu 2

## Fld/Frm Setting

Display Path: MENU > CAMERA ADJUST > MORE

- **FIELD**: Used to eliminate blur when shooting fast-moving objects. The CCD accumulates and outputs the charges, field-by-field, to give pictures showing a minimum of blur, even when the subject is moving fast.
- **FRAME**: Used to produce pictures with the highest possible vertical resolution. The CCD accumulates and outputs the charges frame-by-frame.
- Default: **FIELD**.



If you are using a booster (see page 24), the **FIELD/FRAME** setting remains fixed on **FRAME**.

## Shutter Menus

Display Path: MENU > CAMERA ADJUST > MORE > SHUTTER

The electronic shutter enables you to obtain blur-free pictures of fast-moving subjects and to produce good still images of subjects shot in poor lighting conditions. To change between modes, press the first function command button. Default mode: **OFF**.

**OFF**: Turns off the electronic shutter.

**CCD-IRIS**: Increases the shutter speed automatically when an excessive amount of light passes through the lens. This has the same effect as reducing the lens iris by six stops.

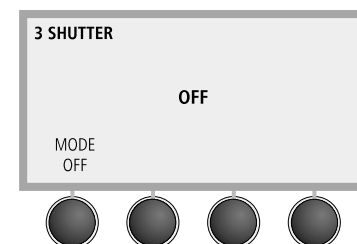

Shutter menu in OFF mode (above) and in CCD-IRIS mode (below)

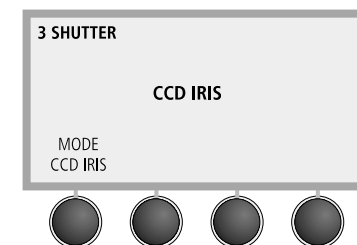

# Controlling The Camera's Video

**C.SCAN:** Sets the shutter speed in units of 1 H (horizontal scanning time; 63.56µs). This setting can be used to reduce horizontal noise when shooting a computer screen.

- **UP and DOWN:** Used to change the shutter speed setting. Do this while observing the picture on a video monitor.
- **Range:** 1/525 H. – 260/525 H.
- **Default:** 260/525 H.

**STEP:** Sets the shutter to one of the following eight speeds: FL (flickerless), 1/125, 1/250, 1/500, 1/1000, 1/2000, 1/4000, and 1/10000 sec.

- **UP:** Increases the shutter speed.
- **DOWN:** Decreases the shutter speed.
- **Default:** FL.

**L EXP:** Sets the shutter speed in units of 1 frame. This mode is useful for shooting a poorly-illuminated object in a dark place.

- **Range:** Field mode: 1-255 FRM (frames).  
Frame mode: 2-256 FRM (frames).
- **UP:** Increases increases the number of frames.
- **DOWN:** Decreases the number of frames.
- **MORE:** Displays **Long Exposure menu 2**.
- **BOOSTER:** Lets you set the focus or color for subjects in poor lighting conditions by allowing 4 frames accumulation and gain adjustment. In such situations, turn booster **ON**, set the focus and color, and then turn it **OFF**. You can then shoot in long exposure mode.
- **W.EN:** Lets you change the output from the **RGB/SYNC** connector on the rear panel. It is enabled only when the unit is in **L EXP** mode.
  - **Sync:** Outputs a composite sync signal. This is the normal setting.
  - **W.EN:** Outputs a **WEN** (timing) pulse. Use this function to synchronize a connected frame memory.

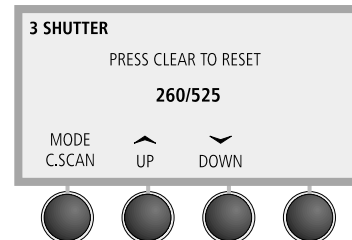

Shutter in C SCAN mode

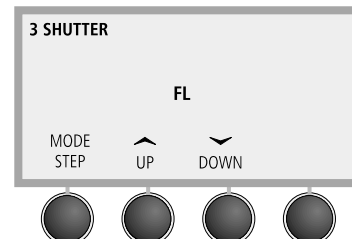

Shutter in STEP mode

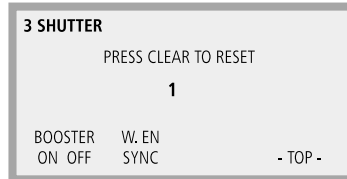
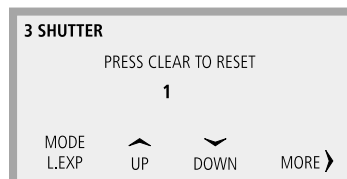

Shutter in L EXP mode- menu 1 (top) and 2 (bottom)

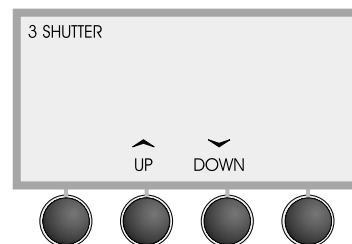

*Shutter Menu (2112)*

*Display Path: MENU > CAMERA ADJUST > SHUTTER*

**UP/DOWN:** UP increases the shutter speed and DOWN decreases the shutter speed.

# Controlling The Camera's Video

## *Lin Mat (Linear Matrix) Setting* Display Path: MENU > CAMERA ADJUST > MORE > MORE

The **Linear Matrix** setting processes images with a color matrix to produce natural colors.

- **ON:** Matrix processing is activated.
- **OFF:** Matrix processing is de-activated.
- **Default:** ON.

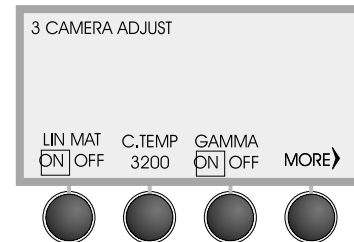

Camera Adjust menu 3

## *C. Temp (Color Temperature) Setting*

Display Path: MENU > CAMERA ADJUST > MORE > MORE

- **3200K:** For indoor shooting.
- **5600K:** For outdoor shooting.
- **Default:** 3200K.

## *Gamma Setting*

Display Path: MENU > CAMERA ADJUST > MORE > MORE

- **ON:** For normal use of the camera. The camera compensates the reproduction characteristics of the monitor CRT to produce natural-tone images.
- **OFF:** The video signal is output linearly from the CCD without gamma compensation.
- **Default:** ON.

## *G Sync Setting*

Display Path: MENU > CAMERA ADJUST > MORE > MORE > MORE

- **ON:** Adds sync to the G signal output from the RGB/SYNC connector of the camera.
- **OFF:** The sync is separate from the G signal output at the RGB/SYNC connector of the camera.
- **Default:** ON.

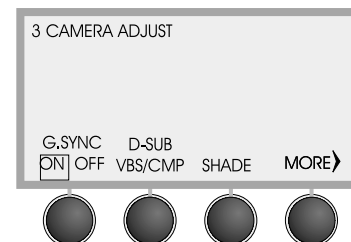

Camera Adjust menu 4

## *D-Sub Setting*

Display Path: MENU > CAMERA ADJUST > MORE > MORE > MORE

- **VBS/CMP:** Changes the output of the RGB/SYNC connector on the camera to either VBS or Component output.
- **VBS/RGB:** Changes the output of the RGB/SYNC connector on the camera to either VBS or RGB output.
- **YC/CMP:** Changes the output of the RGB/SYNC connector on the camera to either Y/C (S-video) or Component output.
- **YC/RGB:** Changes the output of the RGB/SYNC connector on the camera to either Y/C (S-video) or RGB output.

# Controlling The Camera's Video

**Shading Menu**     *Display Path: MENU > CAMERA ADJUST > MORE > MORE > MORE > SHADE*

Use the Shading menu to compensate for uneven color shading throughout the screen. In most situations, this should be set to **OFF**.

- **UP** and **DOWN**: Used to adjust the level of shading.
- **Default**: OFF.

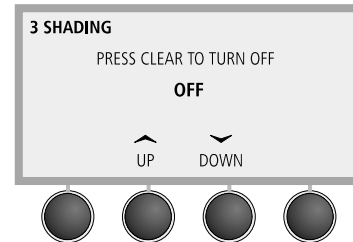

Shading menu

## H. Phase Menu

*Display Path: MENU > CAMERA ADJUST > MORE > MORE > MORE > MORE > H. PHASE*

When an external reference sync signal is connected to the **GEN LOCK** connector on the back of the camera, the camera operates at the frequency of that reference signal. You can use the **Horizontal Phase** function to synchronize the horizontal phase of the camera perfectly with the horizontal phase of the reference signal.

- **UP**: Used to increase the Horizontal Phase.
- **DOWN**: Used to decrease the Horizontal Phase.
- **RANGE**: -99 to +99.
- **Default**: 0.



If the external sync signal is not connected, then this setting adjustment has no effect.

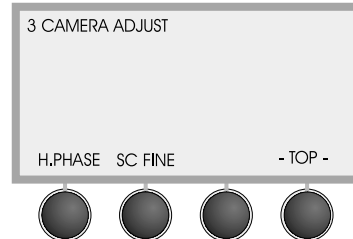

Camera Adjust menu 5

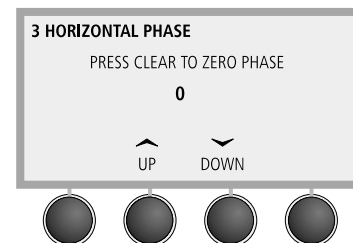

Horizontal Phase menu

## SC Phase Menu

*Display Path: MENU > CAMERA ADJUST > MORE > MORE > MORE > MORE > SC FINE*

When gen locking the camera, use this function for fine adjustments to the **Sub Carrier Phase**. Refer to your *3-CCD Camera Installation and Operations Manual* for information on how to make coarse adjustments to the **Sub Carrier Phase**.



If the external sync signal is not connected, then this setting adjustment has no effect.

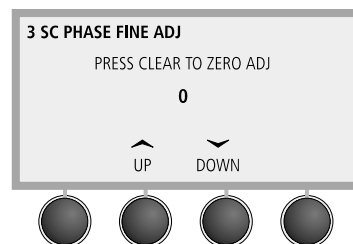

SC Phase Fine menu

# Appendix A: Troubleshooting

If you experience any problems with your CameraMan Shot Director, then please refer to the following Troubleshooting section. If you still have questions, then please contact your authorized reseller or call Grass Valley at (904)596-3500.

## Troubleshooting

**Problem:** *The Shot Director will not power up.*

- Solution:**
- Is the power supply plugged in and the power light illuminated?
  - Is the wall outlet supplying the necessary voltage?
  - Will the power supply operate a CameraMan camera?

**Problem:** *The selected camera doesn't move, or it moves sporadically when the Joystick is moved.*

- Solution:**
- Is the proper CameraMan selected?
  - Does the desired CameraMan's base unit address match the Shot Director selection?

Camera Base Unit	Shot Director Camera
0	1
1	2
2	3
	etc.

- Is autoTRACK on? If yes, press the button on top of the joystick to disable autoTRACK and to enable the joystick to control the camera's movement again.
- Are pan/tilt speed slider controls set to the bottom?
- Are soft stops set too close together?
- Is the Joystick calibrated?
  1. Turn the Power off.
  2. Turn the Power back on.
  3. Press **SETUP** when the opening menu appears.
  4. When the new menu appears, move the pan/tilt through all of its possible positions several times. Also, rotate the zoom control in each direction.
  5. After calibrating the joystick, push **Enter**. After the Joystick zeroes itself, the display returns to the **Home** menu.
- Is Dip Switch 8 on Switch Bank B of the CameraMan base unit enabled? See your CameraMan's manual for instructions.

**Problem:** *The Shot Director doesn't beep when setting a location preset or autoTRACK View.*

- Solution:** Is the **Beep** function in the **Setup Director** menu turned **OFF**? If so, press the function command button to turn it **ON**.

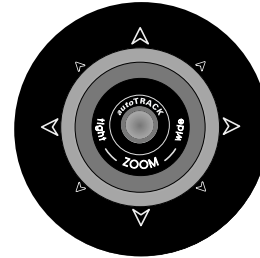
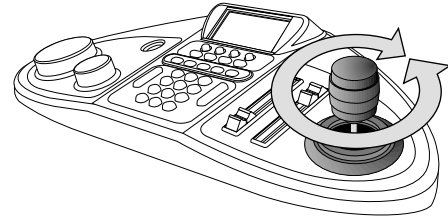

Top view of the joystick controller

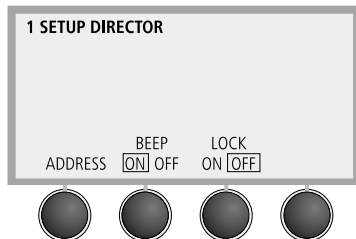
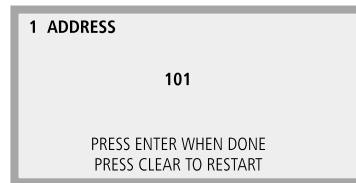
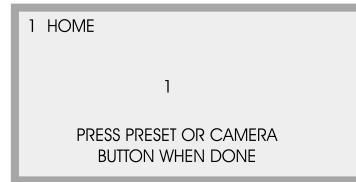



# Appendix A: Troubleshooting

**Problem:** *Shot Director displays a \*COMMUNICATIONS ERROR\**

**Solution:** The Shot Director is not communicating properly with the selected camera.

- Check all the connection cables.
- Verify that the selected CameraMan is on your network.
- Verify that the CameraMan's DIP Switch 7 on Switch Bank A is UP (see the CameraMan operations manual for more details).
- Verify that the CameraMan's ROM card revision # is correct.
- Verify that the base unit address is set accordingly (see page 8).



**Problem:** *CameraMan will not autoTRACK. (autoTRACK version only).*

**Solution:**

- Is autoTRACK turned ON? If not, press the button on top of the joystick to turn autoTRACK ON.
- Is one of the autoTRACK Views selected? If not, press one of the autoTRACK View buttons on the keypad.
- Are the soft stops set too close together?



**Problem:** *Cannot change any camera settings or presets.*

**Solution:** Is the **Lock** function on the **Setup** menu turned **ON**? If it is, then press the function command button beneath **LOCK** to turn it **OFF**.

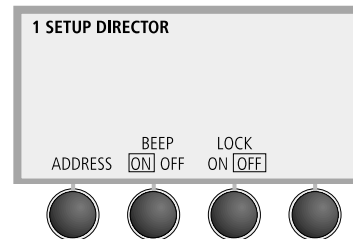

**Problem:** *The 3-CCD menu is not present.*

**Solution:** Is the selected camera a 3-CCD CameraMan model?

**Problem:** *The camera allows me to walk off-screen before it begins to follow me.*

**Solution:** Have you adjusted your Pan/Tilt Window size or Subject Position?

1. Reset the **Pan/Tilt Window Size** and **Subject Position** to 0.
2. Readjust the **Pan/Tilt Window Size** and **Subject Position** settings.
3. Make your Pan/Tilt Window size smaller.
4. Zoom out.

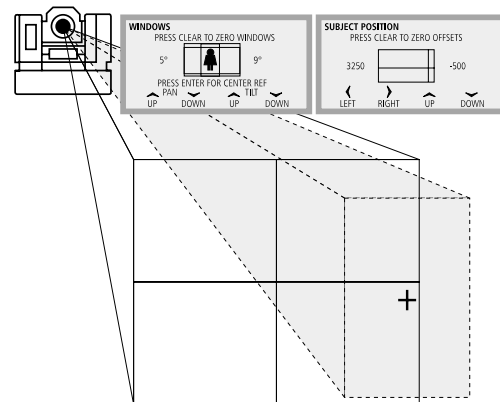

Is the sensitivity too low?

**Problem:** *The camera moves faster in one direction than the other.*

**Solution:** Is the Joystick calibrated? Follow the directions on the previous page to calibrate the joystick.

# Appendix B: Glossary and Specifications

Listed below are some key terms mentioned in this manual, as well as the specifications for the Shot Director. For the specifications on your 1-CCD or 3-CCD camera, see the specifications section of the Installation and Operations Manual that came with the camera.

## Glossary

**CCU (Camera Control Unit)** – A device, external to the camera, that adjusts video characteristics (detail, gains, pedestal, etc.).

**Detail** – Used to sharpen or soften a video image.

**Gains** – The level of the brightest areas of the video image. Gain may be expressed as separate components of red, blue, and green.

**Knee** – Video compression at the brightest parts of a picture. The knee is used to get as much detail as possible from very bright objects.

**Linear Matrix** – Color-correction circuitry used to adjust color without affecting white balance.

**Master Pedestal** – Adjusts the darkness level of the black parts of the image. Use this function to bring out details of heavily shaded areas.

**Paint** – Artificially coloring a video image to compensate for poor lighting or a subject's color characteristics. Also used to match the color of multiple cameras.

**RS-485** – The protocol used by the Shot Director to communicate with the CameraMan camera.

**Tracking Views** – Presets, stored by the CameraMan, that enable you to change the presenter's position in the autoTRACK frame.

**White Balance** – Matching the red, green, and blue picture components to achieve proper color hues.

## Specifications

Display Type . . . . . LCD, H: 1.5 in (3.81 cm) W: 3 in (7.62 cm),  
Adjustable Contrast and Backlight

Pan/Tilt control type . . . Self-Centering joystick, software configured

Iris/Focus control type . . . Rotary encoders

RS-485 Max Distance . . . 2,500 ft (762.2 m)

Power . . . . . 100 - 240VAC 50/60 Hz 100w

Dimensions . . . . . L: 18 in (45.72 cm) H: 5.5 in (13.97 cm)  
D: 8.5 in (21.59 cm)

Weight . . . . . 4.5 lbs. (2.04 kg)

Temperature . . . . . 32° - 100° F (0°-37.78° C)

Humidity . . . . . 0-95% non-condensing

## Maximum Pan/Tilt Travel

The CameraMan camera has a maximum pan range of 359° and a maximum tilt range of 50°. It comes programmed with factory default settings of ± 90° of PAN (left and right) and ±25° of TILT.

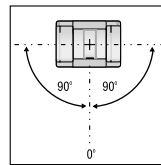

180° Default Pan Settings

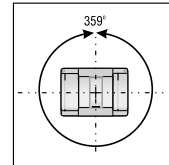

359° Maximum Pan Settings

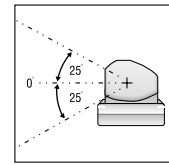

50° Default and Maximum Tilt Settings

# Appendix C: Pinout Diagrams

You'll find the following pinout connections on the back of your CameraMan Shot Director. These diagrams are for your reference.

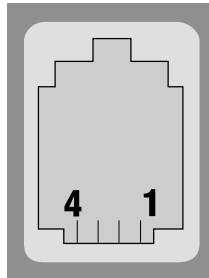

RS-485  
Four position  
Modular Handset

<u>Pin</u>	<u>Signal</u>
1	Ground
2	Signal A
3	Signal B
4	Ground

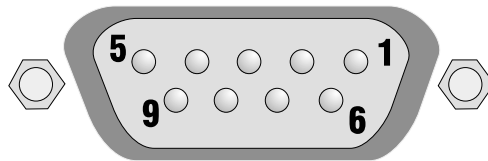

9-pin Female D-9 Sub

<u>Pin</u>	<u>Signal</u>
2	Transmit
3	Receive
5	Ground
1,4,6-9	Not Used

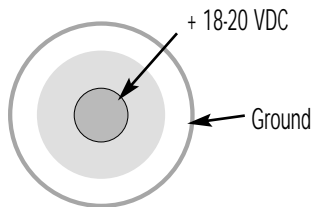

5.5mm DC Power  
Connector

# Appendix D: Default Reset Settings

Your CameraMan Shot Director gives you the power to adjust various camera, autoTRACK, and location preset settings. Below are the default settings, which take effect if you follow the instructions on page 7 to restore the defaults.

## CameraMan Default Settings

System Lock/Unlock . . . . . Unlocked	<b>Default Preset</b>	<b>Preset 2</b>
Tracking . . . . . Off	Pan Position . . . . . 0°	Pan Position . . . . . 45°
Pan Direction . . . . . Normal	Tilt Position . . . . . 0°	Tilt Position . . . . . -10°
Tilt Direction . . . . . Normal	Zoom Position . . . . . Wide	Zoom Position . . . . . Tight
Pan Soft Stops . . . . . +90° to -90°	Iris . . . . . Auto	Iris . . . . . Auto
Tilt Soft Stops . . . . . Cleared	<b>Preset 1</b>	<b>Preset 3</b>
Preset Speed . . . . . 100	Pan Position . . . . . 0°	Pan Position . . . . . -45°
Gain . . . . . AGC	Tilt Position . . . . . 0°	Tilt Position . . . . . 10°
	Zoom Position . . . . . Wide	Zoom Position . . . . . Mid-range
	Iris . . . . . Auto	Iris . . . . . Auto

**Note:** All other position presets remain unchanged.

## autoTRACK Default Settings: 3-CCD (1-CCD)

<b>Default Tracking View</b>	<b>Wide Tracking View</b>	<b>Left Tracking View</b>
Zoom Position . . . . . 0	Zoom Position . . . . . 130 (56)	Zoom Position . . . . . 130 (56)
Iris Position . . . . . Auto	Iris Position . . . . . Auto	Iris Position . . . . . Auto
Pan Subject Position . . . . . 0	Pan Subject Position . . . . . 0	Pan Subject Position . . . . . 1000 (2079)
Tilt Subject Position . . . . . 0	Tilt Subject Position . . . . . 0	Tilt Subject Position . . . . . -231
Pan autoTRACK™ Window . . . 0°	Pan autoTRACK™ Window . . . 4° (3°)	Pan autoTRACK™ Window . . . 6° (3°)
Tilt autoTRACK™ Window . . . 0°	Tilt autoTRACK™ Window . . . 2°	Tilt autoTRACK™ Window . . . 2°
Tracking Sensitivity . . . . . 80	Tracking Sensitivity . . . . . 100 (70)	Tracking Sensitivity . . . . . 80 (70)
<b>Tight Tracking View</b>	<b>Right Tracking View</b>	<b>Mid Tracking View</b>
Zoom Position . . . . . 175 (156)	Zoom Position . . . . . 130 (56)	Zoom Position . . . . . 152 (106)
Iris Position . . . . . Auto	Iris Position . . . . . Auto	Iris Position . . . . . Auto
Pan Subject Position . . . . . 0	Pan Subject Position . . . . . -1000 (-2079)	Pan Subject Position . . . . . 0
Tilt Subject Position . . . . . 0	Tilt Subject Position . . . . . -231	Tilt Subject Position . . . . . 0
Pan autoTRACK™ Window . . . 0° (3°)	Pan autoTRACK™ Window . . . 6° (3°)	Pan autoTRACK™ Window . . . 2°
Tilt autoTRACK™ Window . . . 2°	Tilt autoTRACK™ Window . . . 2°	Tilt autoTRACK™ Window . . . 2°
Tracking Sensitivity . . . . . 110 (70)	Tracking Sensitivity . . . . . 80 (70)	Tracking Sensitivity . . . . . 100 (70)

## Lock Mode

The following settings cannot be changed when the Shot Director is in **LOCKED** mode:

1. All **SETUP** options except for the **LOCK** option itself.
2. All **MENU** options (the **MENU** selection is inaccessible).
3. All **POSITION PRESETS** and **TRACKING VIEWS**.

# Appendix E: LCD Handling Precautions

Due to the delicate nature of the LCD screen on your Shot Director, please make note of the following handling precautions.

1. An LCD screen is a fragile item and should not be subjected to stro mechanical shocks.
2. Avoid applying pressure to the screen's surface. This distorts the glas cause a change in color.
3. In the event of LCD breakage and fluid leakage:
  - Do not inhale, ingest, or make skin contact with the fluid. If cor is made, then rinse immediately.
4. When cleaning the screen, use a soft, damp cloth with a mild solvent, such as Isopropyl or Ethyl alcohol. **DO NOT** use water, ketone, or aromatic.

