



GV CONVERGENT

VERSION 3.3.0

User's Manual

13-00952-030 AS

2021-08-04

www.grassvalley.com

FCC Compliance

In order to comply with FCC/CFR47: Part 15 regulations, it is necessary to use high-quality, triple-screened Media or Monitor cable assemblies with integrated ferrite suppression at both ends.

Patent Information

This product may be protected by one or more patents.

For further information, please visit: www.grassvalley.com/patents/

Copyright and Trademark Notice

Grass Valley®, GV® and the Grass Valley logo and/or any of the Grass Valley products listed in this document are trademarks or registered trademarks of GVBB Holdings SARL, Grass Valley USA, LLC, or one of its affiliates or subsidiaries. All other intellectual property rights are owned by GVBB Holdings SARL, Grass Valley USA, LLC, or one of its affiliates or subsidiaries. All third party intellectual property rights (including logos or icons) remain the property of their respective owners.

Copyright © 2018 - 2020 GVBB Holdings SARL and Grass Valley USA, LLC. All rights reserved.

Specifications are subject to change without notice.

Terms and Conditions

Please read the following terms and conditions carefully. By using GV Convergent documentation, you agree to the following terms and conditions.

Grass Valley hereby grants permission and license to owners of GV Convergent to use their product manuals for their own internal business use. Manuals for Grass Valley products may not be reproduced or transmitted in any form or by any means, electronic or mechanical, including photocopying and recording, for any purpose unless specifically authorized in writing by Grass Valley.

A Grass Valley manual may have been revised to reflect changes made to the product during its manufacturing life. Thus, different versions of a manual may exist for any given product. Care should be taken to ensure that one obtains the proper manual version for a specific product serial number.

Information in this document is subject to change without notice and does not represent a commitment on the part of Grass Valley.

Warranty information is available from the Legal Terms and Conditions section of Grass Valley's website (www.grassvalley.com).

Title	GV Convergent User's Manual
Part Number	13-00952-030 AS
Revision	2021-08-04, 22:42

toc

Table of Contents

1 Introduction	7
Related Documentation	7
Latest Software	7
2 Getting Started With GV Convergent	9
Logging in to GV Convergent	9
Client Server Version Check Warning	10
Navigating Back to Stage	10
Switching User Profiles	11
Viewing Notifications	13
3 Configuration Tasks	15
Required Permissions	16
Area Configurator Tasks	17
Accessing Areas in the GV Convergent	17
Adding an Area	18
Configuring a Controller Group	19
Selecting an Area	23
Deleting an Area	24
Selecting a Graph	25
Creating a new Graph for a Topology	26
Deleting a Graph	28
Logical Level Editor Tasks	30
Accessing the Logical Level Editor	30
Viewing the Default Logical Levels	32
Duplicating a Logical Level	33
Creating the Logical Levels for a UHD 4K Routing Setup	34
Editing a Logical Level	35
Deleting a Logical Level	36
Configuring a New Logical Level	36
Configuring the Logical Levels for the Devices in a Topology	37
Topology Configurator Tasks	39
Accessing the Topology Configurator	39
Refreshing the Topology	42
Viewing the Topology in Full Screen Mode	42
Adding Devices to a Topology	44
Using Quick Config	50
Methods to Link Devices in a Topology	53
Deleting the Connection Between Device Groups	60
Defining Device Properties	61

Deleting a Device From a Topology	65
Activating a Topology	66
Making an Active Topology Inactive.....	67
Unlocking / Relocking a Topology.....	69
Locking an Unlocked Topology	70
Logical Device Table Tasks	72
Accessing the Logical Device Table task	72
About the Multilevel Table and GVOP Devices.....	76
About Automatic Sources or Destinations	76
Setting the Logical Levels to be Displayed in the Multilevel Table	78
Adding a Source or Destination to the Logical Level Table	79
Configuring Streams for New Sources / Destinations.....	80
Bulk Assigning Logical Levels in the Multilevel Table.....	84
Adding and Configuring a Destination	85
Using Megasource.....	85
Deleting a Source, Destination, or Virtual XPTS	87
Exporting a Logical Device Table.....	88
Selecting all Devices in the Logical Device Table for Export	88
Configuring Virtual Crosspoints (XPTs)	88
Filtering Lists, Table Columns, Sources, and Destinations.....	97
Category Configurator Tasks	98
Accessing the Category Configurator	98
Creating Categories for the Sources and Destinations in Your Topology	100
Re-ordering Category Content	102
Assigning a Keystroke Label to a Source or Destination	103
Creating a Keystroke Label.....	104
Panel Configurator Tasks	105
Accessing the Panel Configurator	105
Creating a New Panel.....	107
Duplicating a Pre-Existing Panel	109
Viewing another Panel	110
Configuring a Panel's Properties	111
Adding Panel Pages	113
Adding Actions to a Panel	114
Adding Resources to the Panel.....	117
Creating a Single-Destination Work Flow Panel.....	127
Adding the New Panel to the Topology	129
Panel Configuration Example Using Categories with Custom Navigation	132
GPIO Configurator Tasks	142
Accessing the GPIO Configurator	142
Adding a GPIO Rule.....	144
Configuring a GPI to Trigger an Event	145
Configuring a Script to Trigger a GPO	147
Deleting a GPI or GPO Action Configuration	149
Activating / Deactivating a Rule.....	150
Duplicating a Rule.....	150
Deleting a Rule.....	151
Choosing an Alias for all Rules	151
Stream Configurator Tasks	152
Accessing the Stream Configurator	152

Stream Configurator Filters Tool	155
Pasting IP addresses from a Microsoft Excel worksheet into the Stream Configurator.....	155
Editing Unicast and Multicast IP Addresses	157
Setting SDP Templates for one or more Streams	157
Selecting Stream Configurator Rows	159

4 Special Device Configuration Tasks 161

Description of Common Device Properties	162
Configuring a GV Node Device	163
Configuring an IPG-3901 / IPG-4901 Device.....	174
Connecting an IPG-4901 device.....	178
Device properties	178
Example Topology Using an IPG-4901.....	179
Configuring an IPVU Device.....	180
Configuring an IQMix, IQUCP, or UCP-3901 Device.....	183
How to Know if a Spigot is an Input or an Output	184
Configuring UHD 4K Two-Sample Interleave Division IP Streams for use with an IQMix, IQUCP, UCP- 3901, or IPVU Device	185
Configuring UHD 4K Quad-Link SDI Streams for use with an IQMix, IQUCP, UCP-3901, or IPVU Device ... 190	
Configuring an MV-820-IP Multiviewer Device.....	194
Configuring a Kahuna IP Production Switcher Device	198
Configuring a K-Frame Production Switcher	201
Adding NMOS Devices to a Topology	208
To Add an NMOS Device to a Topology	214
Using SDP Parameters to Take a Stream from a non-NMOS Device to an NMOS Device.....	216
Configuring Cisco DCNM Network Switch Devices.....	220
Configuring the Network Switch's Flow Policies	220
Configuring a DCNM Network Switch Device	223
Direct Flow Orchestration: How To Create a Static Flow with a Cisco Network Switch	226
Configuring Network Switch Redundancy to Support SMPTE ST 2022-7	230
Configuring an NVISION Hybrid Series Router	235
Configuring Router Devices.....	241
Configuring a Router's Control Port	244
Configuring a Device that Supports Audio Breakaway/Shuffling such as Audio Live	252
About Audio Live.....	252
About the Routing Path of Audio Channels.....	253
Prerequisites	253
Configuring an Audio Live device in GV Convergent.....	257
Known Audio Live limitations.....	260
Audio Live Redundancy Support	260
Configuring an IQAMD40 Device.....	265
About IQAMD40.....	265
IQAMD40 Integration in GV Convergent.....	265
Automatically Creating AES67 Audio Channels for Sources and Destinations	266

5	Monitoring Tasks	269
	Overview	269
	Path Manager Tasks	270
	Accessing the Path Manager	271
	Viewing Information about the Tie-lines	273
	Viewing Information about the Streams	273
	Viewing Information about the Destinations	274
	Viewing Information about the Status	275
	System Status Task	277
	Accessing the System Status Task	277
	Forcing the Inactive Controller to be the Active Controller	279
	Permissions	281
	Audio Live Usage	282
	Accessing the Audio Live Usage Task	282
6	Control Tasks	285
	Overview	285
	Alias Editor Tasks	286
	Accessing Alias Editor Tasks	286
	Adding Aliases	287
	Renaming Source and Destination Labels	288
	Router Control Tasks	289
	Accessing the Router Control Task	289
	Performing a Take in Router Control	290
	Creating Salvos	293
	Selecting the Name of Sources and Destinations	295
7	Administration Tasks	297
	The User Management Task Overview	298
	Creating User Profiles	299
	Granting Access Permissions to an Area	301
	Viewing Permissions by Role	304
	Setting a User ID for Lock, Protect, and Release with NDAC NP0016 / NP0017 Northbound Interfaces	307
	General commands	309
	Device-based support	309
	Port-based support	311
	User ID and Lock, Protect, and Release	312
	GV Convergent user external id configuration	312
	How to...	312

1 Introduction

The purpose of this guide is to provide a brief introduction to GV Orbit Control and its features.

When you log in to GV Orbit Control you open the Stage.

The GV Orbit Control Stage presents a series of tiles, which are arranged in the order you would perform the tasks if you were to configure a GV Orbit system from start to finish. Each task builds on the last. It all begins by defining one or more areas. Once you have area, you can add logical levels. Then, you can create a topology.

These tasks are described in the chapters that follow.

Related Documentation

Use the following related documentation to configure GV Convergent and to better understand the available features. You can obtain the latest product documentation from the Documentation Library section of Grass Valley's website (www.grassvalley.com/docs/gvconvergent).

Part Number	Document Title
GVB-1-0491F-EN-DS	GV Convergent Datasheet
13-00952-010	GV Convergent Release Notes
13-00952-040	GV Convergent Quick Tour of Admin Tasks
13-00952-030	GV Convergent User's Manual

Latest Software

You can obtain the latest GV Orbit software from Grass Valley Technical Support. See [Grass Valley Technical Support](#), on page 845.

Getting Started With GV Orbit Control



This chapter describes the following tasks:

- [Launching GV Convergent](#), on page 9
- [Logging in to GV Convergent](#), on page 9
- [Navigating Back to Stage](#), on page 10
- [Switching User Profiles](#), on page 11
- [Viewing Notifications](#), on page 13

Launching GV Orbit Control

Once GV Orbit Control is installed on your computer, the shortcut icon appears on your desktop.

For details on installing GV Orbit Control for the first time, refer to *GV Orbit, Quick Tour of Admin tasks*.

Logging in to GV Orbit Control

Tip: Before logging in to GV Orbit Control ensure that you have a valid **user name** and **password**, as well as the **Management IP address** of GV Orbit Admin.

To log in to GV Orbit Control

- 1 Click the GV Orbit Control icon on your PC.
The GV Orbit Control login screen appears.

The screenshot shows the login interface for the GV Convergent IP/SDI Router Control System. At the top left is the Grass Valley logo. The main title is 'GV CONVERGENT' in a purple box, followed by 'IP/SDI ROUTER CONTROL SYSTEM'. Below this is copyright information: 'Copyright © 2013-2020 Grass Valley Canada. All rights reserved.' A disclaimer states: 'This product may be protected by one or more patents. For further information, please visit: www.grassvalley.com/patents/'. The login form includes four fields: 'User name:' (text input), 'Password:' (password input), 'Server:' (dropdown menu with '10.37.72.47' selected), and 'Remember me:' (checkbox). At the bottom are 'Log in' and 'Cancel' buttons, and a 'Version:' label.

- 2 Enter your user name and password in the **User name** and **password** text boxes.
- 3 Enter the Management IP address of the GV Orbit Admin in the **Server** text box.
- 4 Click **Log in**.

Client Server Version Check Warning

A warning is displayed if the GV Orbit Control's software version is different from the software version currently running on the connected server. In this case, it is strongly recommended that you download and reinstall the GV Orbit Control's software from the server so that the client and server software versions will match: for details on installing GV Orbit Control, refer to *GV Orbit, Quick Tour of Admin tasks*.

If both client and server software versions are the same, no warning will be displayed and the GV Orbit Control opens normally.

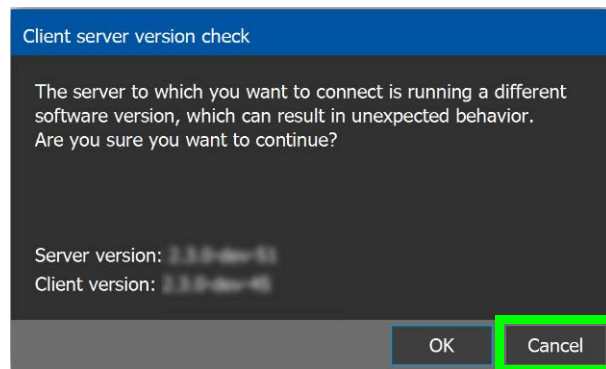

Click **OK** to continue to run the client application regardlessly: this can result in software crashes, database corruption, or other unexpected behavior. Running mismatched software versions is untested and unsupported. Click **Cancel** to go back to the login screen and then close and upgrade your GV Orbit Control.

Navigating Back to Stage

The Stage is the main entry point to configure GV Orbit Control. At any time, you can return to the Stage view.

To navigate back to Stage

- 1 Open GV Orbit Control to any task.
- 2 Do one of the following:
 - Click the Stage tab at the bottom of the UI.
 - Click the plus button at the bottom of the UI.

Tip: The second option is useful, if you have a lot of tasks open.

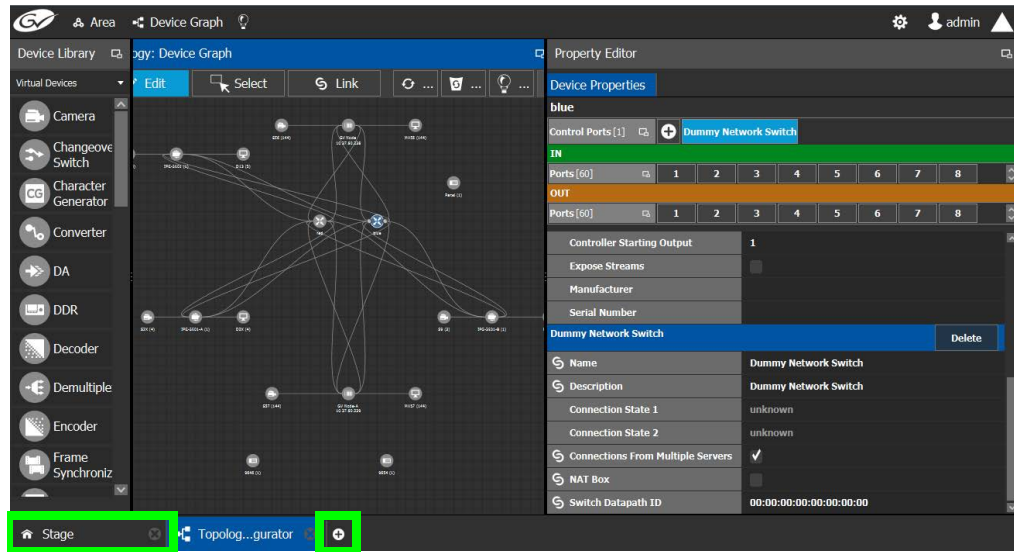

The home or Stage view appears.

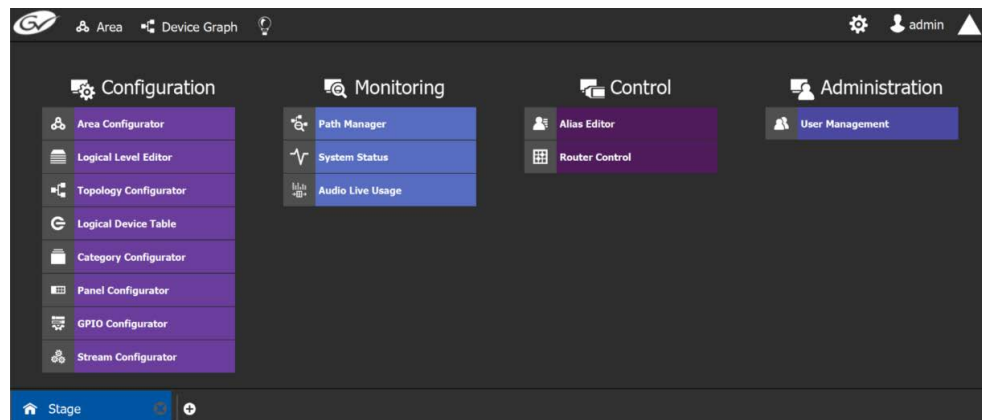

Switching User Profiles

From the Stage or any open task, you can change to another user profile.

Note: Before switching to another user profile, ensure that you have the required user name, password, and Management IP address.

To switch to another user profile

- 1 Click on the user profile name at the top right of GV Orbit Control.

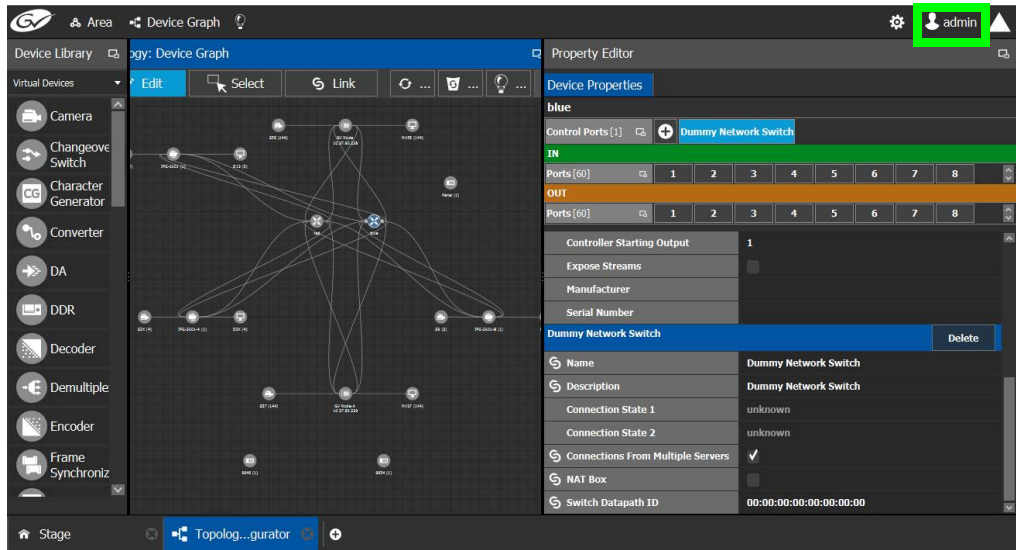

A confirmation message appears.



- 2 Click **Log out** to continue.
The Log in screen appears.

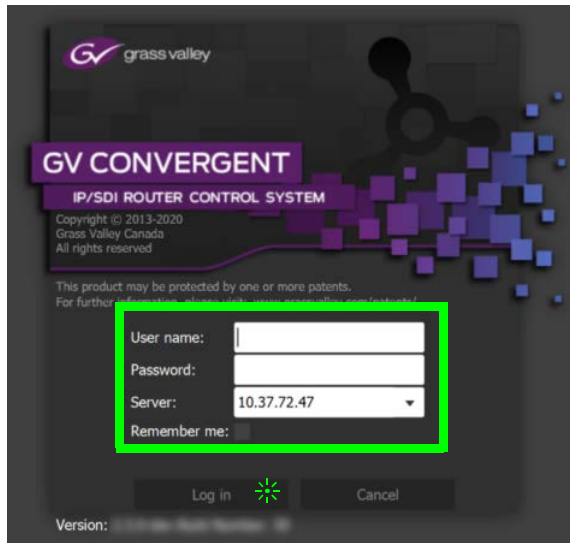

- 3 Enter your login credentials in the **User name** and **Password** text boxes.
- 4 Enter the Management IP address of the GV Orbit server you are connecting to in the **Server** field.
- 5 Click **Log in**.

GV Orbit Control opens to the view applicable to the user.

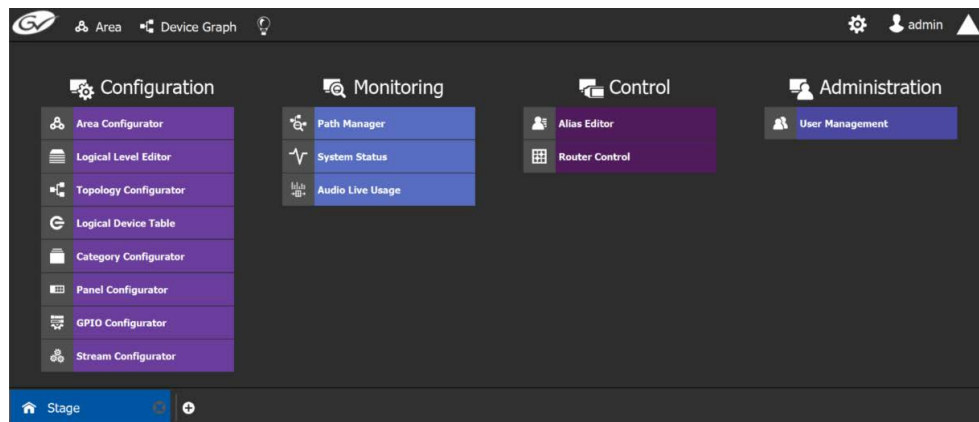

Note: Access permissions vary according to the permissions granted to the user's role. For further information, see [Administration Tasks](#), on page 297.

Viewing Notifications

A notification is an indicator that an event has occurred.

To view your notifications

- 1 Log in to GV Orbit Control.

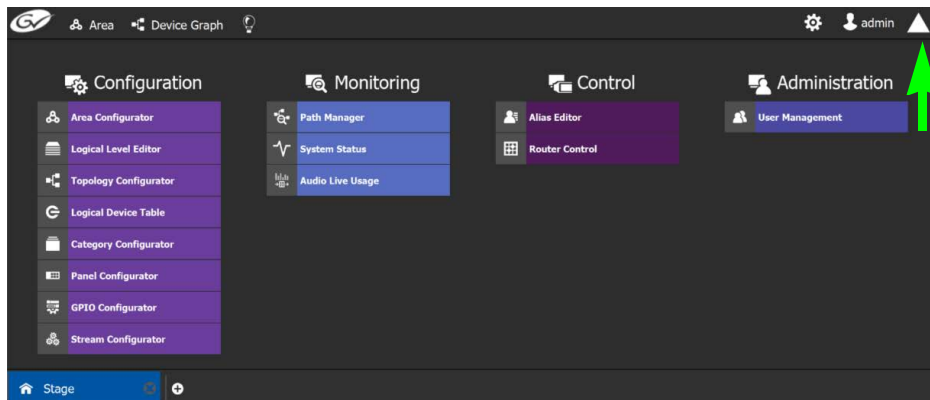

- 2 Click on the up arrow in the top right corner of the UI.
The Notification window appears.

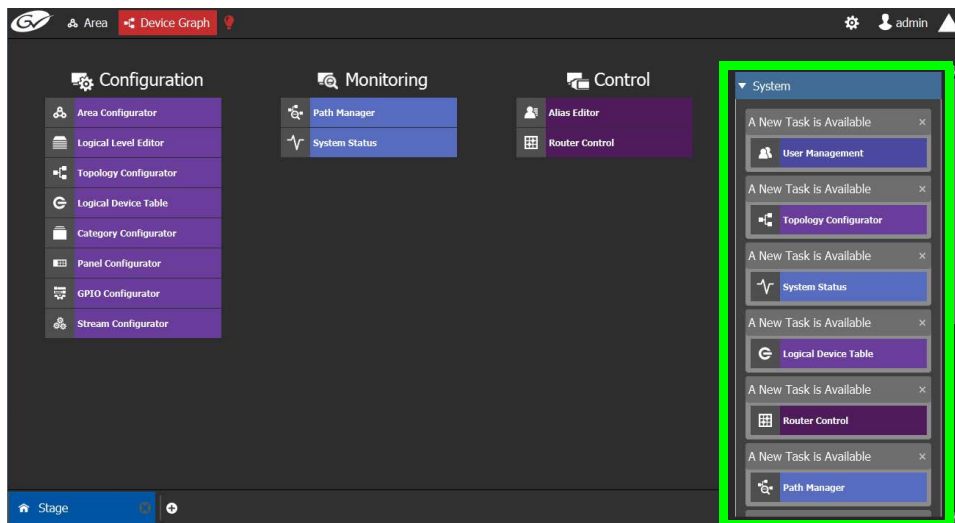

- 3 Expand the **System** list. The list of new events appears.
- 4 Click on a listed event on the right to view it in the UI.

3 Configuration Tasks

The Configuration tasks in GV Orbit Control are used for creating and maintaining areas, topologies, categories, and panels.

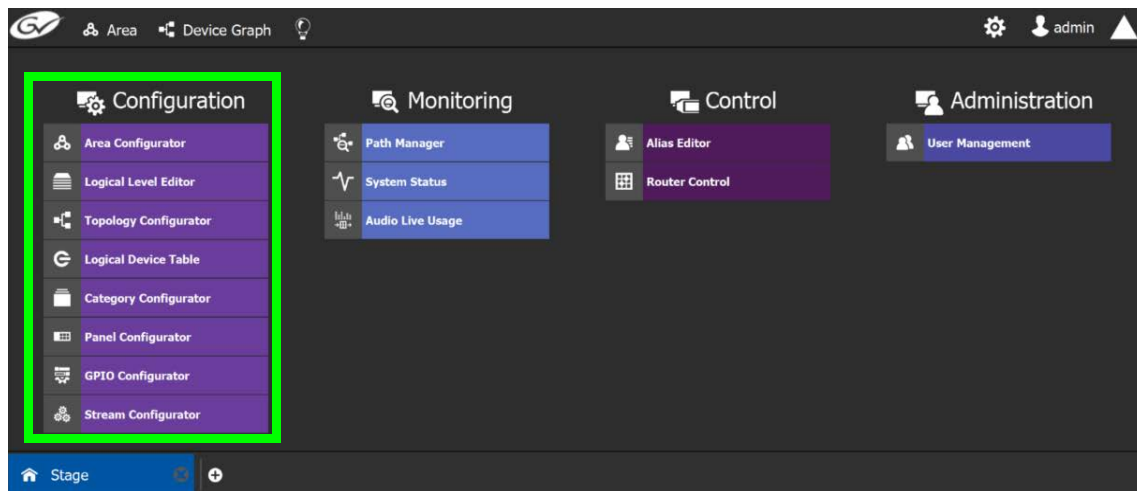

The Configuration Tasks are described under the following headings:

- [Area Configurator Tasks](#), on page 17
- [Logical Level Editor Tasks](#), on page 30
- [Topology Configurator Tasks](#), on page 39
- [Logical Device Table Tasks](#), on page 72
- [Category Configurator Tasks](#), on page 98
- [Panel Configurator Tasks](#), on page 105
- [GPIO Configurator Tasks](#), on page 142
- [Stream Configurator Tasks](#), on page 152

Required Permissions

Only users who are assigned to the Administrators role have View, Edit, and Delete permissions in the Area task. All other configuration tasks are accessible to users with either Administrator or Engineer rights only. For more information, see [Viewing Permissions by Role](#), on page 304.

Area Configurator Tasks

The Area Configurator task is used for configuring the *Areas* and controllers in GV Orbit Control.

An *Area* is container that is used for grouping together a subset of resources within a system. Typically, these resources are closely related, by physical location, functionality, ownership, and/or logical organization. An area is managed by a single controller group, which is made up of:

- a single controller
- or optionally, two redundant controllers to provide 1:1 fail-over protection

This section describes the following:

- [Accessing Areas in the GV Convergent](#), on page 17
- [Adding an Area](#), on page 18
- [Configuring a Controller Group](#), on page 19
- [Selecting an Area](#), on page 23
- [Deleting an Area](#), on page 24

Accessing Areas in the GV Orbit Control

All configuration in GV Orbit Control begins by creating one or more areas. Once you have the areas defined, you can add the logical levels, the topologies, and so on.

To configure the area in GV Orbit Control

- 1 Open GV Orbit Control Stage. See [Navigating Back to Stage](#), on page 10.
- 2 Select **Configuration > Area Configurator**.

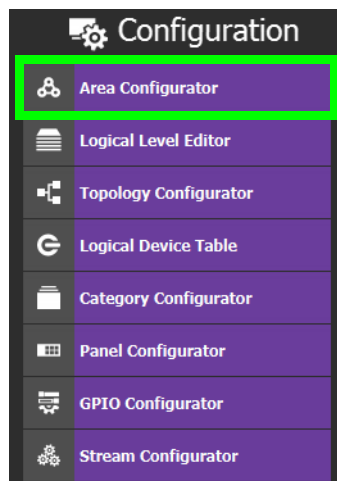

The Area Graph appears.

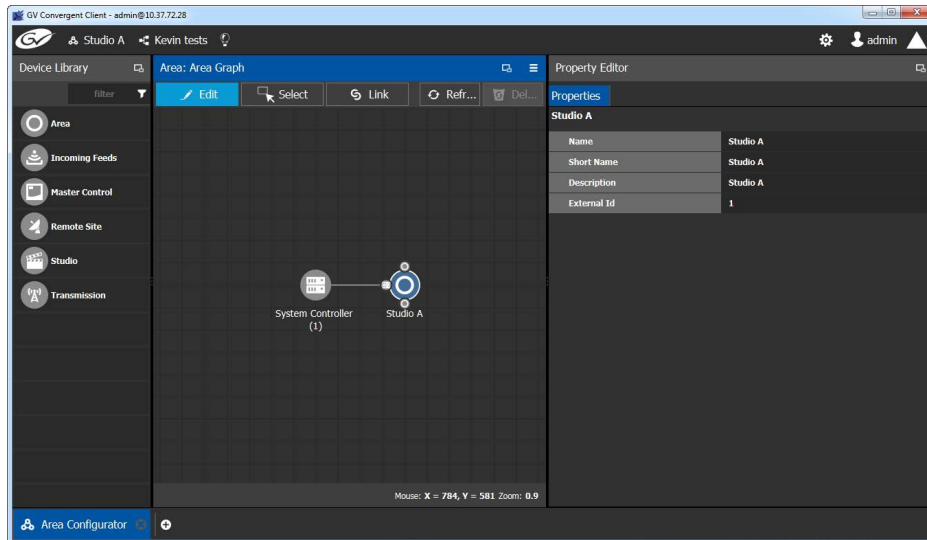

By default, there is one area, called Area. Use the **Property Editor** on the right to rename it and make it easy to identify within your system.

- 3 Select the Area to access the **Property Editor**.
You are automatically in Edit mode. **Edit** is highlighted in the bar at the top.
- 4 Enter the required information in the **Name**, **Short Name**, **Description**, and **External ID** fields to identify the area.
- 5 Repeat the procedure for each area in your system.

Adding an Area

You can create multiple areas for your system. This can facilitate configuration and control tasks. Smaller subsets are easier to bring into focus and manage.

To add an area

- 1 Open GV Orbit Control Stage. See [Navigating Back to Stage](#), on page 10.
- 2 Select **Configuration > Area Configurator**. See [Accessing Areas in the GV Convergent](#), on page 17.

This opens the Area Graph.

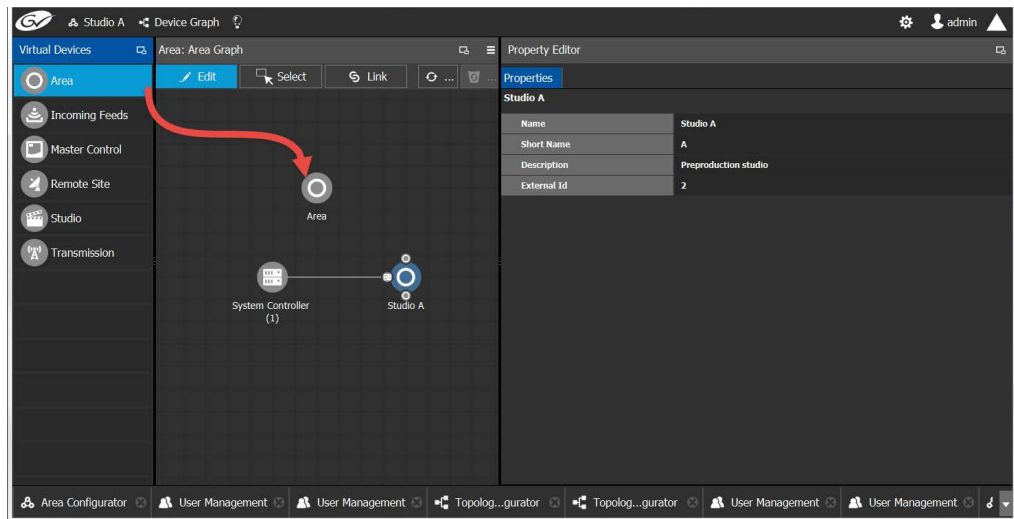

- 3 Select the area tile on the left.
- 4 Drag it to the Area Graph.
- 5 Repeat the procedure as many times as required to add all the areas you require.

Note: Currently, GV Orbit Control supports one Area. Area inter-connectivity and multiple areas (Incoming Feeds, Master Control, Remote Site, Studio, and Transmission) are not supported.

Configuring a Controller Group

By default, there is one area and one System Controller group on the Area Configurator Device Graph.

A controller group can have one or more areas. The controller is a physical or virtual server that runs the GV Orbit software.

A Controller group can be made up of either one or two controllers. You need two controllers to implement redundancy or failover protection. In the redundant configuration, one controller is active and the other is on standby. If there is a problem, such as a network connection loss, the standby controller becomes the active controller, automatically. In addition, you can force the standby controller to become the active controller by performing a manual failover operation, at any time.

To configure a controller group

- 1 Open GV Orbit Control Stage. See [Navigating Back to Stage](#), on page 10.
- 2 Select **Configuration > Area Configurator**. See [Accessing Areas in the GV Convergent](#), on page 17.

By default, there is one controller and one area on the graph.

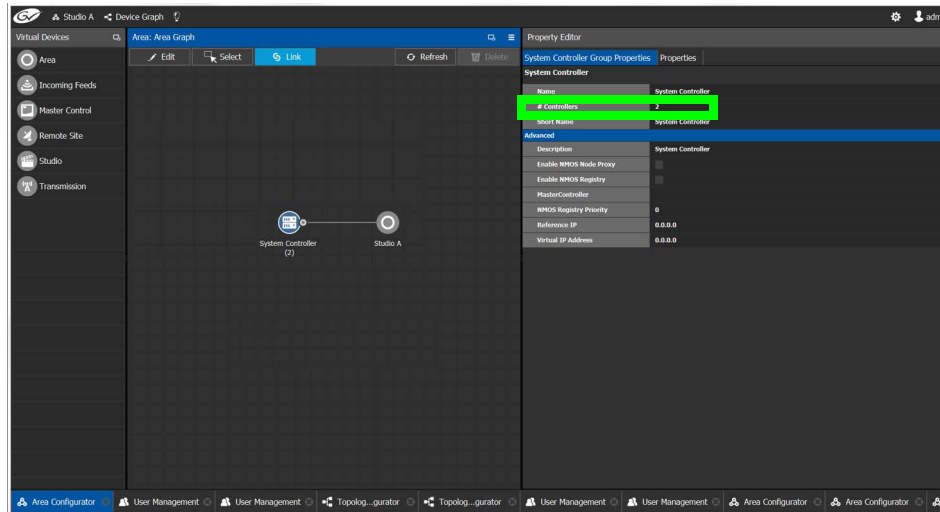

- 3 Select the bubble for the **System Controller** you are configuring.
- 4 Select the **System Controller Group Properties**.

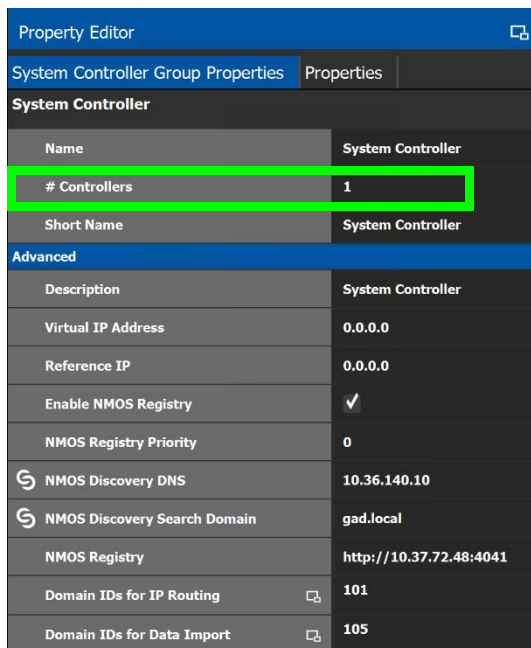

The following properties can be configured for the panel. See also [Description of Common Device Properties](#), on page 162.

Parameter	Description
Name	The name or identifier for this system controller group.
# Controllers	Enter 2 in the field if you are setting up redundancy. Otherwise, enter 1 . You can only have one or two system controllers in a group.
Description	An optional description for this system controller group.

Parameter	Description
Virtual IP Address	This is the virtual IP address to communicate with the active server in a GV Orbit Server cluster (when a redundant configuration is used). If a GV Orbit Server cluster is not being used, use the GV Orbit Server administration IP address for devices instead of this IP Address. For example, in a cluster configuration, a soft panel can be configured to point to this virtual IP address. When a failover happens, control is maintained through the panel using this virtual IP address. See also System Status Task , on page 277 for more information about server clusters and failover.
Reference IP	Set the IP of a machine that is always on. After a failover the server that can connect first to this IP will become the master.
Enable NMOS Registry	Set to start GV Orbit Control's NMOS registry located on the GV Orbit Server. For more information about how to configure and use GV Orbit Control's NMOS registry, see To configure GV Convergent for use with NMOS , on page 208.
NMOS Registry Priority	Sets the priority of GV Orbit Control's built-in registry that is started when the <i>Enable NMOS Registry</i> option is enabled.
NMOS Discovery DNS	GV Orbit Control can automatically discover an NMOS registry through DNS-SD when the NMOS Discovery DNS and NMOS Discovery Search Domain parameters are set. For more information about how to configure and use GV Orbit Control's NMOS registry, see To configure GV Convergent for use with NMOS , on page 208.
NMOS Discovery Search Domain	
NMOS Registry	This shows the current NMOS Registry Query API URL (hostname / IP address and port number). For more information about how to configure and use GV Orbit Control's NMOS registry, see To configure GV Convergent for use with NMOS , on page 208.
Domain IDs for IP Routing	Only applications / devices that use the same Domain IDs can communicate with each other on the network. For a list of such devices, see GVOP Devices , on page 46. This is a comma separated list of domain IDs on which you want to discover devices and communicate with them. The default value for Grass Valley equipment is 101 . Valid range: 0 to 232 .
Domain IDs for Data Import	This is for future use.

5 Select the **Properties** tab.

- 6 Select **1** under **System Controller** to configure the first controller.

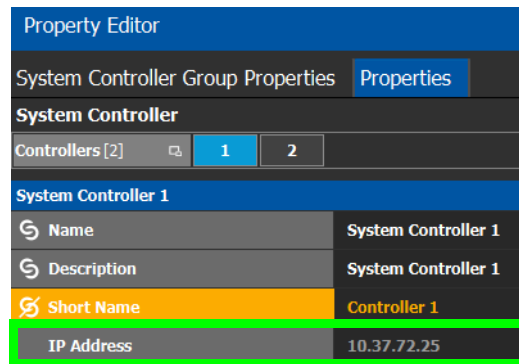

The following properties can be configured for the individual system controller that form the system controller group. See also [Description of Common Device Properties](#), on page 162.

Parameter	Description
Name	The name or identifier for this system controller instance.
Description	An optional description for this system controller instance.
Short Name	A nickname used wherever the controller is specified. This name should be limited to 8 characters or less in length. This requirement is important if you are using NVISION panels as they use the Short Name to display device names and NVISION hardware can display a maximum of 8 characters for a device name. Otherwise, a longer nickname can be used.
IP Address	The network IP address for this system controller instance. This field for System Controller 1 is populated automatically with this system controller's Management IP address. This cannot be changed. When system controller redundancy is used (System Controller 2 is available), set the network IP address for System Controller 2.

- 7 Select tab **2** under **System Controller** to configure the second controller.

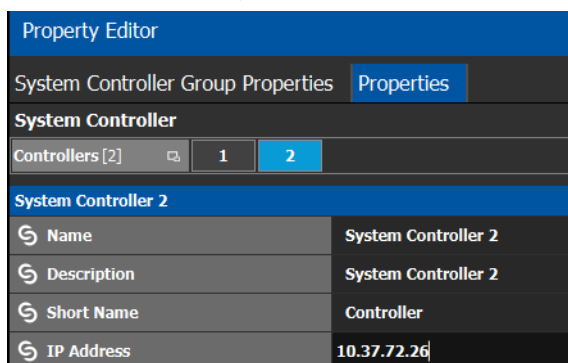

- 8 Update the identification fields for the second controller and set the network IP address for System Controller 2: see the table above.

A confirmation message is displayed:

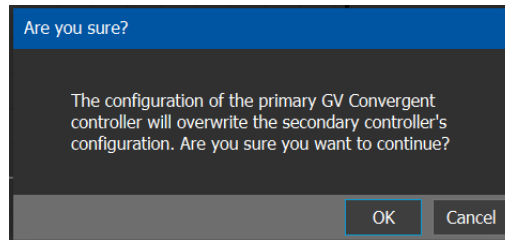

- 9 Click **OK** to continue.

Notes

When redundancy has been configured, System Controller 2 joins the Controller group automatically as the standby controller. It becomes the active controller in the event of an automatic or manual failover.

When you click OK, the database from Controller 1 is copied to Controller 2

You can view the health of both controllers on the System Status task. The System Status Task page will show the status of the controllers at all times, and the right hand section shows the health of devices specific to a topology. However, you must create your areas and topologies first. See [System Status Task](#), on page 277.

Selecting an Area

You must select an area before you can create or maintain a topology within it. Only one area can be selected at a time.

To switch from one selected area to another

- 1 Open GV Orbit Control Stage. See [Navigating Back to Stage](#), on page 10.

The currently selected Area is displayed at the top of the interface.

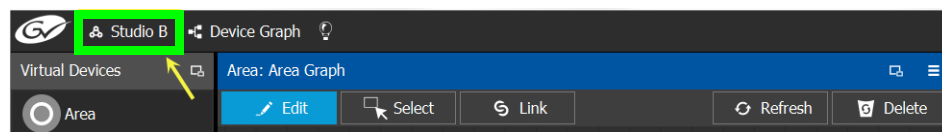

Note: You can perform this procedure from Stage or from any open task. You can always select an area.

- 2 Click on this area.

A secondary window appears.

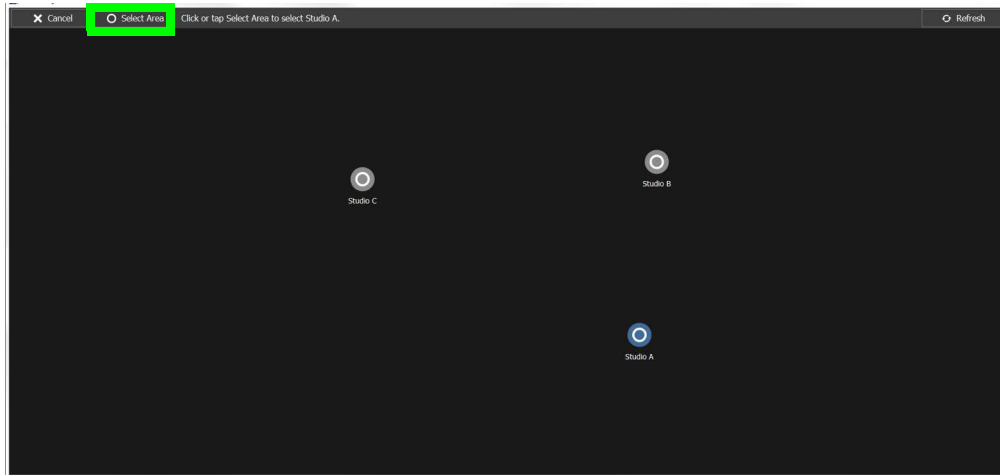

- 3 Click on the area that you to select.
In the screen shot above, this is Studio A.
- 4 Click **Select Area** at the top of the window.

Deleting an Area

Note: You cannot delete the currently selected Area. If necessary, make another Area active first. See [Selecting an Area](#), on page 23.

To delete an area

- 1 Select another Area other than the one you are going to delete. See [Selecting an Area](#), on page 23.
- 2 Open GV Orbit Control Stage. See [Navigating Back to Stage](#), on page 10.
- 3 Select **Configuration > Area Configurator**. See [Accessing Areas in the GV Convergent](#), on page 17.
- 4 Click on the Area you want to delete.
- 5 Click **Delete**  at the top of the logical level editor.
- 6 A confirmation message appears. It lists the topologies created in the Area.

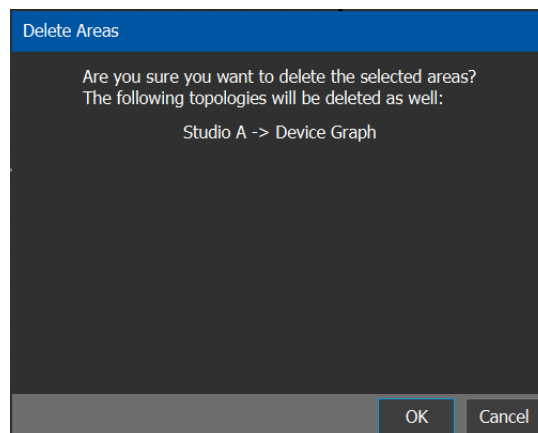

- 7 Click **OK** to continue.

Selecting a Graph

In the Area Configurator, you define the various Areas in your system. Within each Area, you can create multiple Graphs, and each Graph contains a *Topology*. Each topology shows a part of how the various physical and logical devices are arranged and interconnected within the broadcast facility.

To work on a topology, you first need to select the Graph in which the Topology is held. You can work on only one topology at a time.

To select a Graph

Note: A Graph must be created in an area. Then, it is available only in the area where it was created.

- 1 Select the required Area. See [Selecting an Area](#), on page 23.
- 2 Click the Graph icon  that holds the currently active topology at the top left of GV Orbit Control.

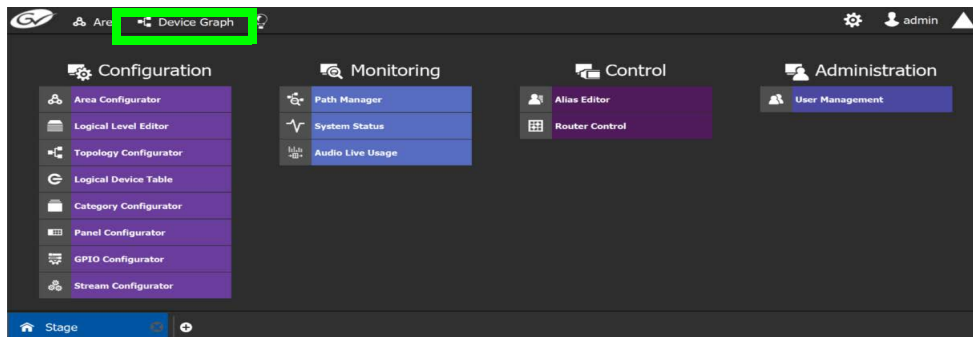

This opens the graphs window. It shows the currently-available graphs for the selected Area. Each Graph contains a Topology.

- 3 Double-click the Graph you want to update or select the Graph you want to update and then click **Load**.

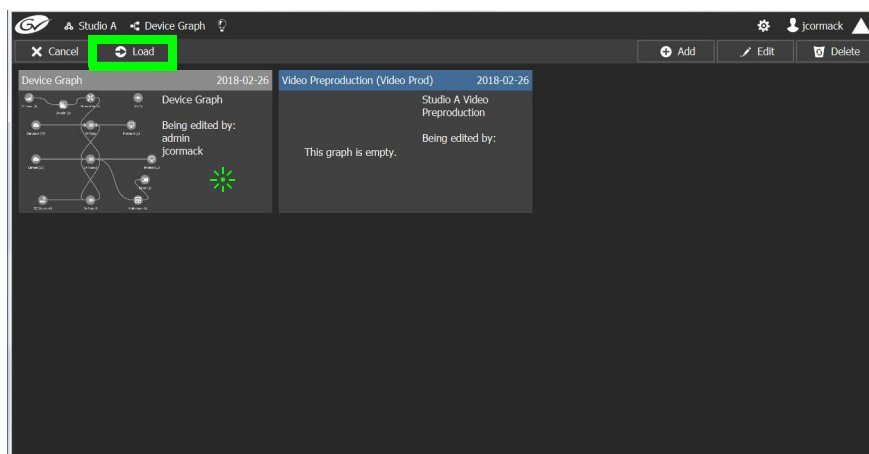

Now, any configuration work you carry out will be on this selected Graph.

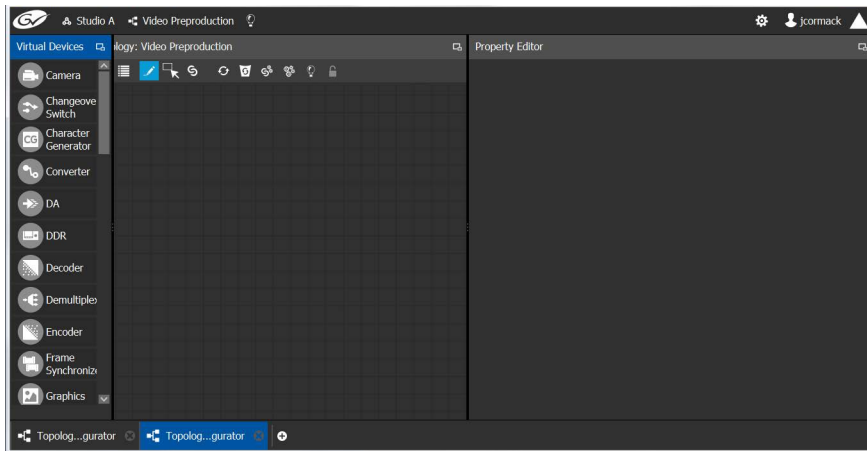



If the topology is new, the Graph is blank. The next step is to begin adding devices. See [Adding Devices to a Topology](#), on page 44.

Creating a new Graph for a Topology

To create a new topology

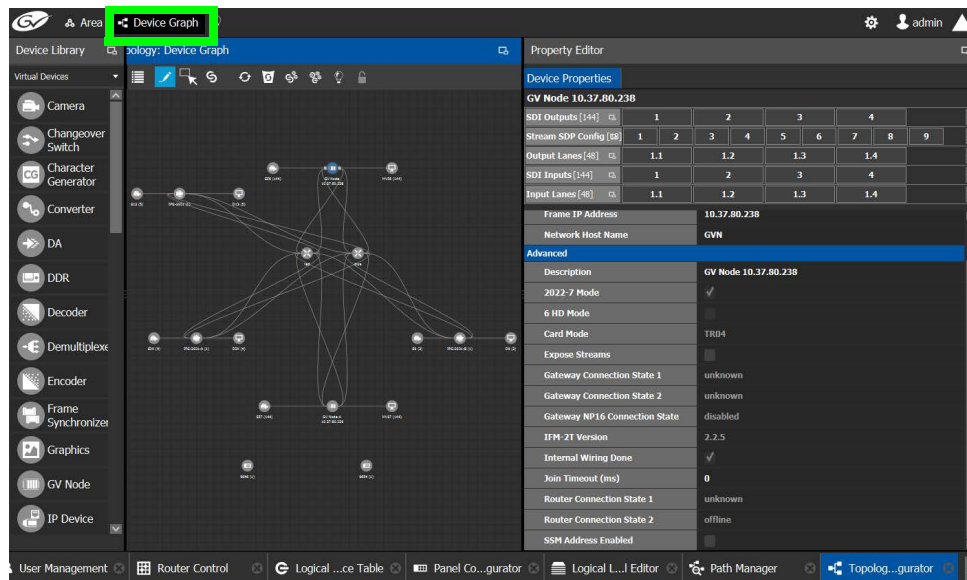
- 1 Open GV Orbit Control Stage. See [Navigating Back to Stage](#), on page 10.
- 2 Select the required Area. See [Selecting an Area](#), on page 23.



- 3 Click the Graph icon  that holds the currently active topology at the top left of GV Orbit Control.

This opens a secondary window.

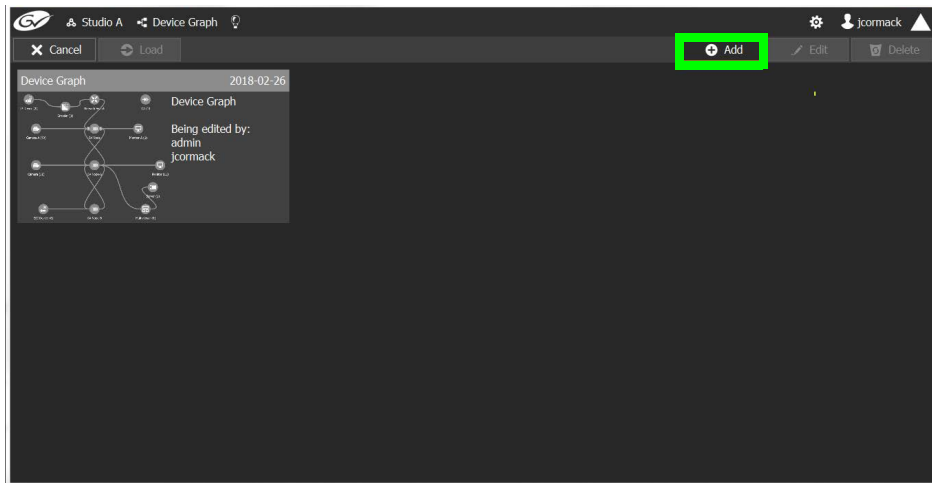

4 Click **Add** .

The Create New Graph window appears.

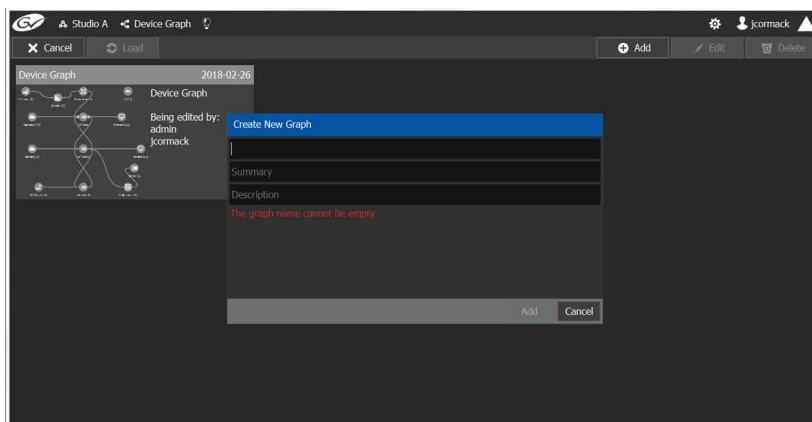

5 Enter a name for the new topology and enter meaningful text in the **Summary** and **Description** fields for easy identification.

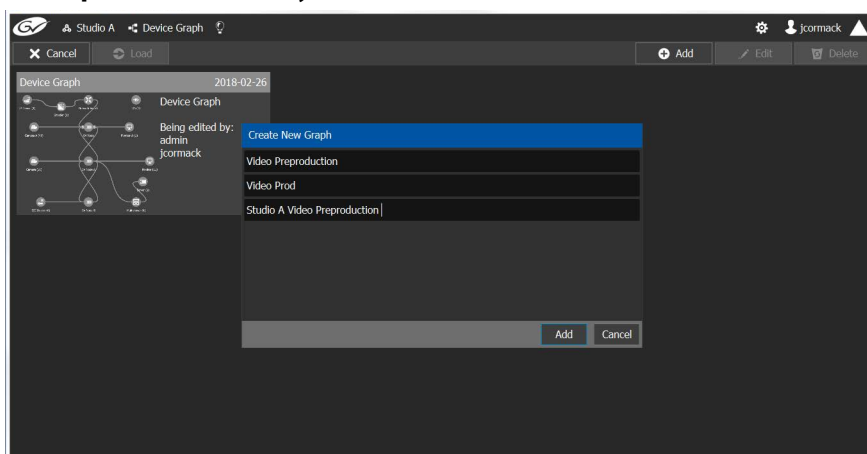

6 Click **Add** on the Create New Graph window.

The new topology appears in the list box with the existing topologies.

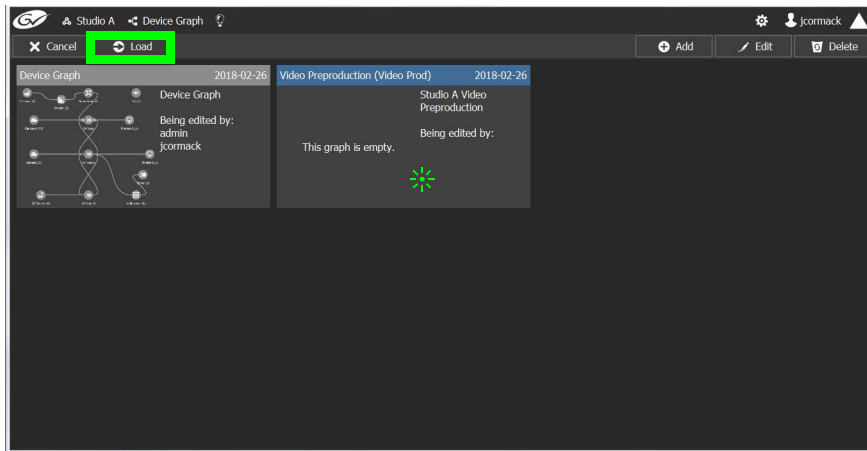

- 7 Select the new topology and click **Load**. Or double-click the topology. The selected topology is opened.

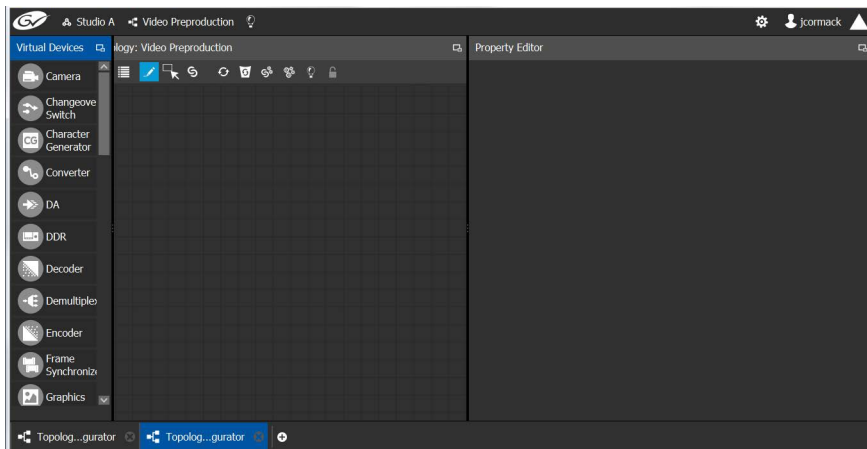

If the topology is new, the Topology is blank. The next step is to begin adding devices. See [Adding Devices to a Topology](#), on page 44.

Deleting a Graph

Only inactive graphs / topologies can be deleted. See [Making an Active Topology Inactive](#), on page 67. You cannot delete all graphs from GV Orbit Control; at least one graph must always be present.

To delete a Graph

- 1 Select the required Area. See [Selecting an Area](#), on page 23.
- 2 If you are deleting the active topology, you must first make it inactive. See [Making an Active Topology Inactive](#), on page 67.

- 3 Click the Graph icon  that holds the currently active topology at the top left of GV Orbit Control.

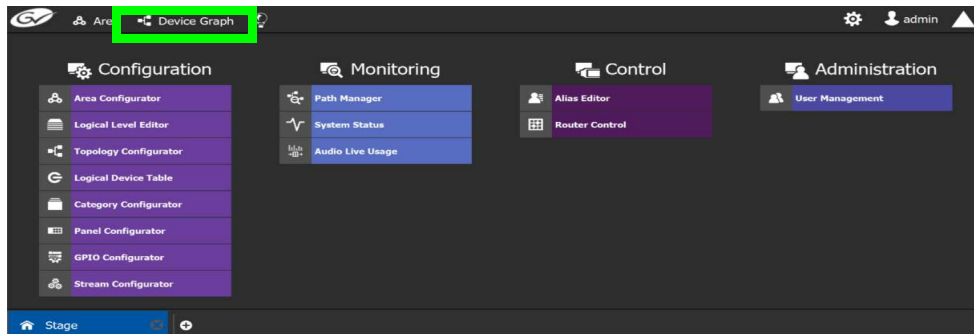

This opens the graphs window. It shows the currently-available graphs for the selected Area.

- 4 Select the Graph you want to delete and then click **Delete**.

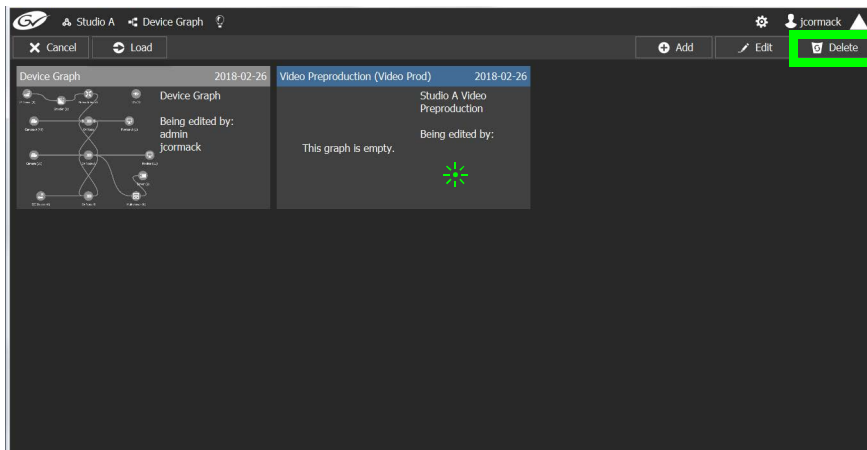

Deleting the last Graph

You cannot delete all graphs from GV Orbit Control; at least one graph must always be present. To delete the last graph, proceed as follows.

- 1 Create a new graph (see [Creating a new Graph for a Topology](#), on page 26)
- 2 Make the new graph active ([Activating a Topology](#), on page 66).
- 3 Delete the previous graph.

Logical Level Editor Tasks

Logical levels allow for the definition of compatibility and shuffling rules. This gives you complete control of the path definition to prevent routing of incompatible levels. For example, Logical levels are used to identify a stream's video resolution, the number of audio channels, ancillary data, and so on.

Every unique type of stream format in your facility should have a unique Logical Level. These levels are then assigned to sources and destinations (in the Logical Device Table; see [Logical Device Table Tasks](#), on page 72). This allows GV Orbit Control's routing system to make takes between sources and destinations with signal types that are compatible with each other, and with the underlying hardware, so that takes can be successfully made in the real world.

This section describes the following:

- [Accessing the Logical Level Editor](#), on page 30
- [Viewing the Default Logical Levels](#), on page 32
- [Duplicating a Logical Level](#), on page 33
- [Editing a Logical Level](#), on page 35
- [Deleting a Logical Level](#), on page 36
- [Configuring a New Logical Level](#), on page 36
- [Configuring the Logical Levels for the Devices in a Topology](#), on page 37

Accessing the Logical Level Editor

Use the Logical Level Editor to define new logical levels and to view the compatibility of the default levels.

To access the Logical Level Editor Task

- 1 Open GV Orbit Control Stage. See [Navigating Back to Stage](#), on page 10.
- 2 Select an area.
- 3 Select **Configuration > Logical Level Editor**.

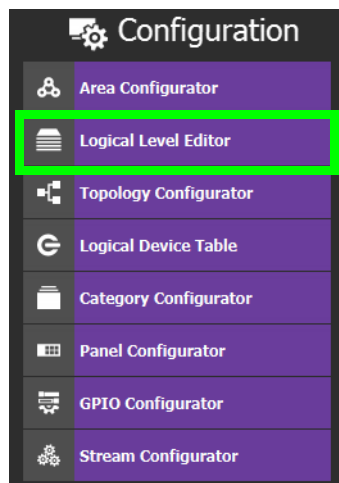

The Logical Level Editor appears.

Note: Only users who are assigned to the Administrators or Engineers role in the selected area have View, Edit, and Delete permissions in the Logical Level Editor task. See [Viewing Permissions by Role](#), on page 304.

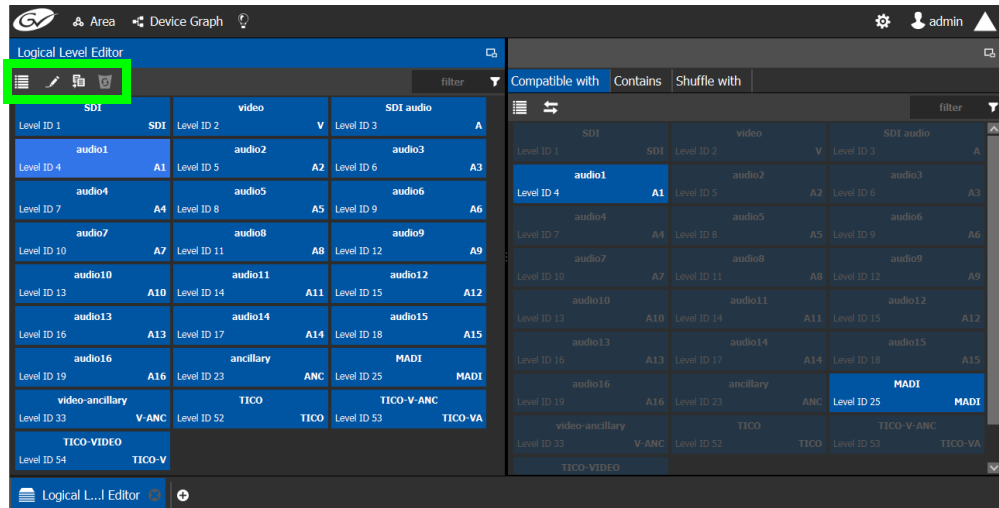

Note: Before you can open the Logical Level Editor, you must open an Area and a Topology. Logical levels are defined specifically for each topology.

The Logical Level Editor has two columns:

- The first column contains tiles for all default logical levels along with the logical levels you have added.
- The second column has three tabs: *compatible with*, *contains* and *shuffle with*. The *shuffle with* allows a user to configure which audio levels can be shuffled with which. See [Configuring Virtual Crosspoints \(XPTs\)](#), on page 88.

Logical Level Editor Menu

The Logical Level Editor menu has the following menu options.

Icon	Description
	Edit a logical level's properties. See Editing a Logical Level , on page 35.
	Make a copy of the currently-selected logical level. See Duplicating a Logical Level , on page 33.
	Remove the currently-selected logical level. See Deleting a Logical Level , on page 36.

Viewing the Default Logical Levels

The default logical levels are represented by the first tiles displayed in the **Logical Level Editor** column, beginning with video, then audio, ancillary, and finally AES67. When you create new logical levels, they are added after these ones.

You can change the Short Label and Level ID of a default Logical Level, but not the Name. Click  Edit to do so. Also, you cannot delete a default level.

The Audio Live device uses AES67 audio levels. See [AES Logical Levels that are used for IP Audio Streams](#), on page 255 for more information.

Verifying the Compatibility of the Default Logical Levels

Compatibility defines which Logical Levels are compatible when making a take. This is shown in the **Compatible with** tab shown below. When a source and destination use the same Logical Level, or the two Logical Levels are compatible with each other, then a take is possible between the source and destination.

Certain default Logical Levels are compatible with other Logical Levels. For example, **AES67-16** is compatible with **SDI audio**. That is to say, a take between an **AES67-16** source and an **SDI audio** destination is allowed by the router system. See also [AES Logical Levels that are used for IP Audio Streams](#), on page 255.

When you create a Logical Level, you always modify the compatibility between these Logical Levels according to the required source / destination signal types.

To verify the compatibility of Logical Levels

- 1 Open GV Orbit Control Stage. See [Navigating Back to Stage](#), on page 10.
- 2 Select **Configuration > Logical Level Editor**. See [Accessing the Logical Level Editor](#), on page 30.

The Logical Level Editor appears.

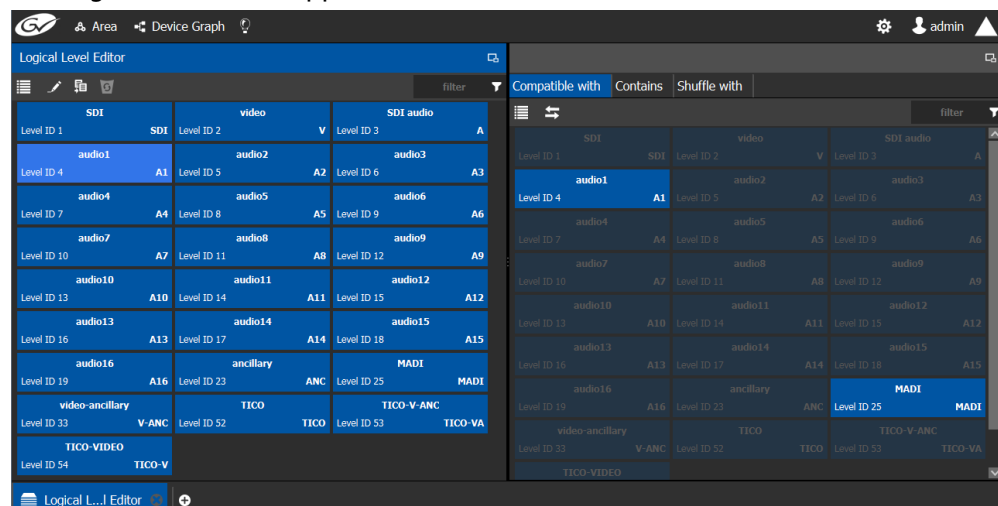

- 3 Select a logical level tile on the left.

The tiles for the logical levels it is compatible with are highlighted in the right column.

Note: A logical level is always compatible with itself.

Verifying the Component Signal Types of the Default Logical Levels

Like the compatibility, the signal types of the default logical levels is predefined and cannot be changed. When you create a Logical Level, you always modify the signal type components.

To verify the signal types of the default logical levels

- 1 Follow the procedure under [Verifying the Component Signal Types of the Default Logical Levels](#), on page 33.
- 2 When you select a tile for a logical level in **Logical Level Editor**, the compatibility is highlighted in the **Contains** tab.

Duplicating a Logical Level

A pre-existing logical level can be copied to reuse that logical level's configuration properties and then you only need to modify the necessary logical level properties as required for the new application.

Notes

Logical levels are specific to topologies. In another topology, you won't see the logical levels you create in the currently selected topology.

Only SDI and TICO levels can be duplicated.

To duplicate a logical level

- 1 Open GV Orbit Control Stage. See [Navigating Back to Stage](#), on page 10.
- 2 Select **Configuration > Logical Level Editor**. See [Accessing the Logical Level Editor](#), on page 30.
- 3 Select a pre-existing level on the left-hand panel that you want to duplicate.

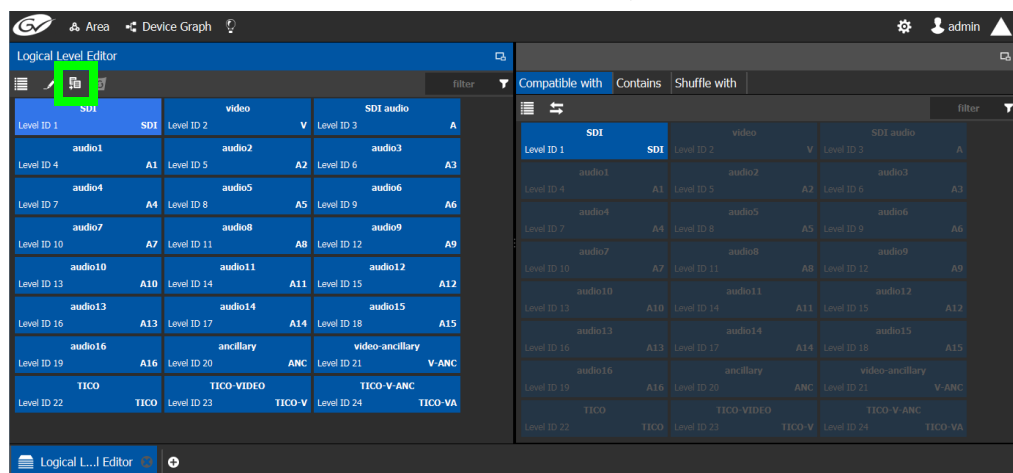

- 4 Click **Duplicate**  at the top of the interface.

The Logical Level configuration window opens.

Level To Duplicate	SDI
Name Prefix	
Name Suffix	HD
Short Label Prefix	
Short Label Suffix	HD
Starting Level ID	36
<input type="button" value="Ok"/> <input type="button" value="Cancel"/>	

- 5 Enter meaningful names to identify the level in the **Name Prefix**, **Name Suffix**, **Short Label Prefix**, and **Short Label Suffix** text boxes.
- 6 Enter a unique identifier in the **Starting Level ID** text box.
- 7 Click **OK**.

A tile for your new logical level is displayed in the left hand column.

video-ancillary		TICO-V-ANC		TICO-VIDEO	
Level ID 33	V-ANC	Level ID 34	TICO-VA	Level ID 35	TICO-V
Level ID 36	SDIHD	Level ID 37	VHD	Level ID 38	AHD
Level ID 39	A1HD	Level ID 40	A2HD	Level ID 41	A3HD
Level ID 42	A4HD	Level ID 43	A5HD	Level ID 44	A6HD
Level ID 45	A7HD	Level ID 46	A8HD	Level ID 47	A9HD
Level ID 48	A10HD	Level ID 49	A11HD	Level ID 50	A12HD
Level ID 51	A13HD	Level ID 52	A14HD	Level ID 53	A15HD
Level ID 54	A16HD	Level ID 55	ANCHD	Level ID 56	V-ANCHD

See [Configuring the Logical Levels for the Devices in a Topology](#), on page 37.

Creating the Logical Levels for a UHD 4K Routing Setup

For an example of how to create the logical levels for UHD routing when a quad-link signal path is used, see:

- [Configuring UHD 4K Two-Sample Interleave Division IP Streams for use with an IQMix, IQUCP, UCP-3901, or IPVU Device](#), on page 185.
- [Configuring UHD 4K Quad-Link SDI Streams for use with an IQMix, IQUCP, UCP-3901, or IPVU Device](#), on page 190.

Editing a Logical Level

Use the following procedure to modify a logical level’s identification information. The **Audio** setting marks that the level is an audio level.

To edit a logical level

- 1 Open GV Orbit Control Stage. See [Navigating Back to Stage](#), on page 10.
- 2 Select **Configuration > Logical Level Editor**. See [Accessing the Logical Level Editor](#), on page 30.
- 3 Select a level on the left-hand panel that you want to edit.

Note: For the default logical levels, you can modify the Short Label and Level ID. You cannot modify the Name.

- 4 Click **Edit** at the top of the logical level editor.

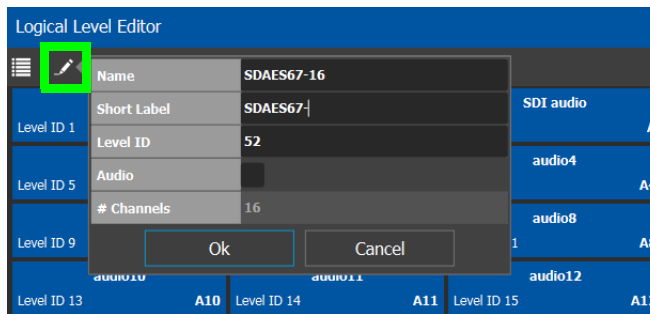

- 5 Modify the properties as required.

Parameter	Description
Name	The level’s name.
Short Label	A shortened name for the level.
Level ID	A unique identifier for this level.
Audio	When set, this level will appear in the Shuffle with tab of the right pane for shuffling rules. See Configuring Virtual Crosspoints (XPTs) , on page 88.
# Channels	When available, this shows the number of audio channels supported by this level. The Audio Live device uses a range of levels, each one supporting a different number of audio channels. See AES Logical Levels that are used for IP Audio Streams , on page 255 for more information. See also Configuring a Device that Supports Audio Breakaway/Shuffling such as Audio Live , on page 252.

- 6 Click **OK**.

Deleting a Logical Level

Use the following procedure to delete a logical level you have created that is no longer required in the selected topology.

Note: You cannot delete the default logical levels. The Delete button is disabled when you click on these levels.

To delete a logical level

- 1 Open GV Orbit Control Stage. See [Navigating Back to Stage](#), on page 10.
- 2 Select **Configuration > Logical Level Editor**. See [Accessing the Logical Level Editor](#), on page 30.
- 3 Select the tile for the logical level you want to delete.

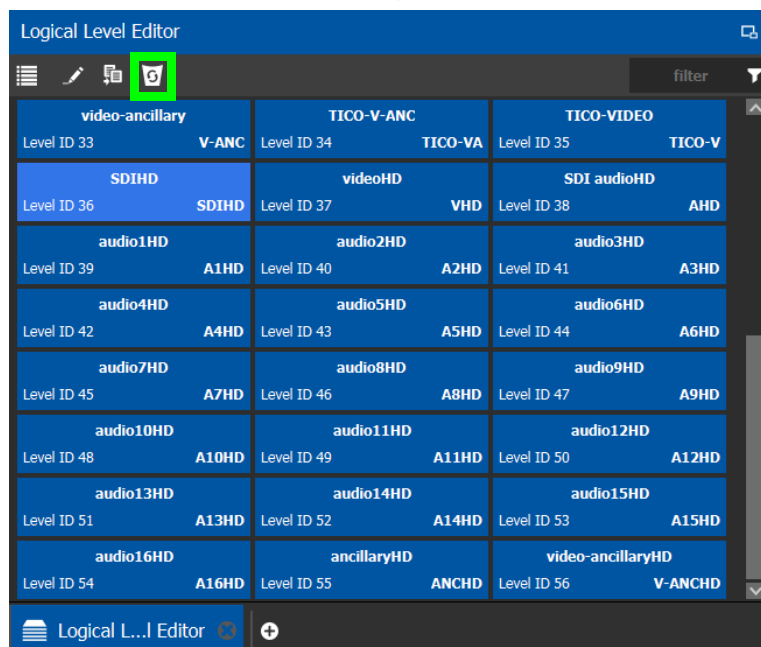

- 4 Click **Delete** at the top of the logical level editor.

Note: There is no confirmation for the deletion.

Configuring a New Logical Level

Use the following procedure to configure a new logical level. This determines which signal types are compatible with this level.

To configure a new logical level

- 1 Open GV Orbit Control Stage. See [Navigating Back to Stage](#), on page 10.
- 2 Select **Configuration > Logical Level Editor**. See [Accessing the Logical Level Editor](#), on page 30.

- 3 Select the tile for the logical level you want to configure.

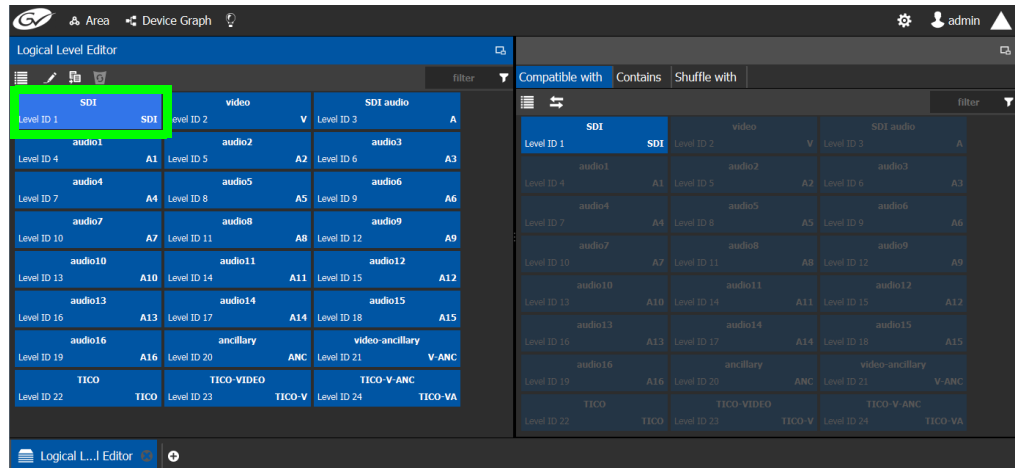

The tile for your new logical level is automatically highlighted in the right hand column.

- 4 Select the tiles for the signal types in the right hand column that are compatible. Click a tile a second time to deselect it.

Configuring the Logical Levels for the Devices in a Topology

Use the following procedure to set the logical levels for the device's sources and destinations in your topology. Logical levels can be used to define the type of signal carried on a physical connection between physical devices. If compatibility is not an issue, the default logical levels may be utilized.

To configuring an area in GV Orbit Control

- 1 Select the required topology in the area. See [Accessing the Topology Configurator](#), on page 39.

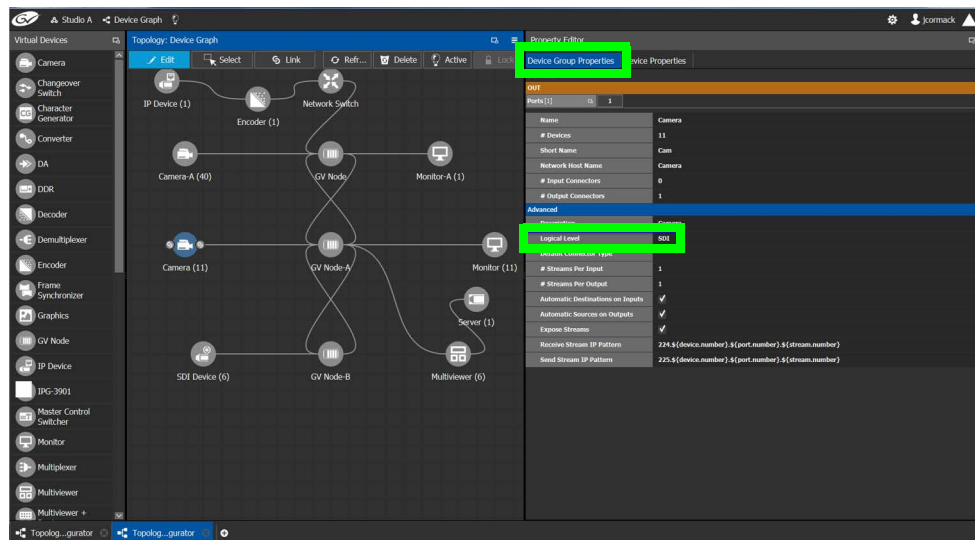

- 2 Select the device for which you want to configure its logical level.
In the above example, the camera bubble is selected. SDI is the default logical level for cameras.

- 3 Select Device Group Properties.
- 4 Select the **Logical Level** parameter in the **Property Editor**.
This opens the Logical Level list.

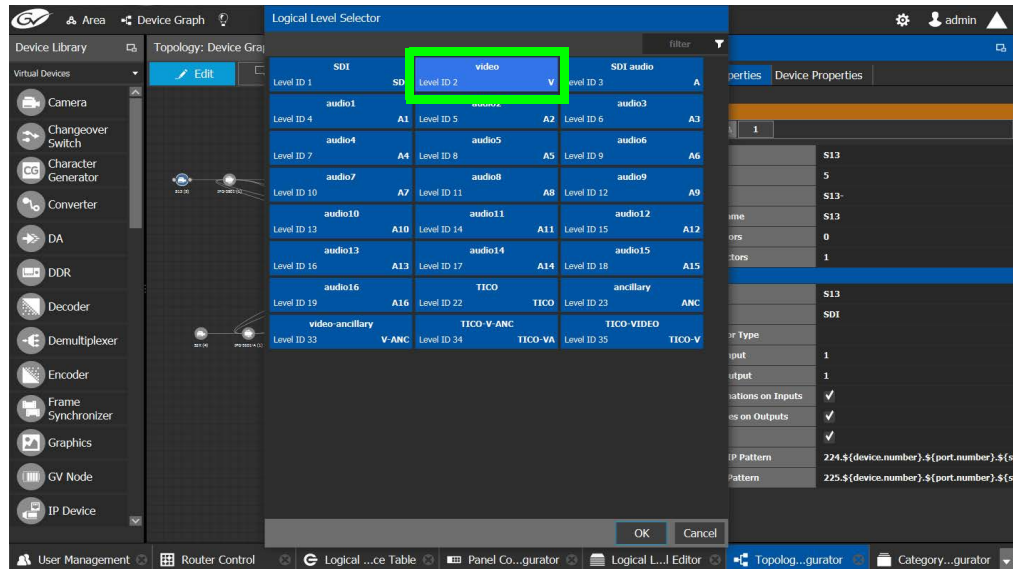

- 5 Select the required logical level for the device group.

Topology Configurator Tasks

In the Area Configurator, you define the various Areas in your system. Within each Area, you can create multiple Graphs, and each Graph contains a *Topology*. The topologies show how the various physical and logical devices are arranged and interconnected within the broadcasting facility. See [Area Configurator Tasks](#), on page 17 and [Selecting a Graph](#), on page 25.

These sections describes the following:

- [Accessing the Topology Configurator](#), on page 39
- [Selecting a Graph](#), on page 25
- [Refreshing the Topology](#), on page 42
- [Creating a new Graph for a Topology](#), on page 26
- [Adding Devices to a Topology](#), on page 44
- [Methods to Link Devices in a Topology](#), on page 53
- [Defining Device Properties](#), on page 61
- [Deleting a Device From a Topology](#), on page 65
- [Activating a Topology](#), on page 66
- [Making an Active Topology Inactive](#), on page 67
- [Unlocking / Relocking a Topology](#), on page 69
- [Locking an Unlocked Topology](#), on page 70

Certain devices require a detailed procedure to configure them; see [Special Device Configuration Tasks](#), on page 161 for more information about these devices.

Accessing the Topology Configurator

You can access the Topology Configurator from Stage or from any open task. Access permissions are required. See also [Selecting a Graph](#), on page 25.

To access the Topology Configurator from Stage

- 1 Open GV Orbit Control Stage. See [Navigating Back to Stage](#), on page 10.
- 2 Select **Configuration > Topology Configurator**.

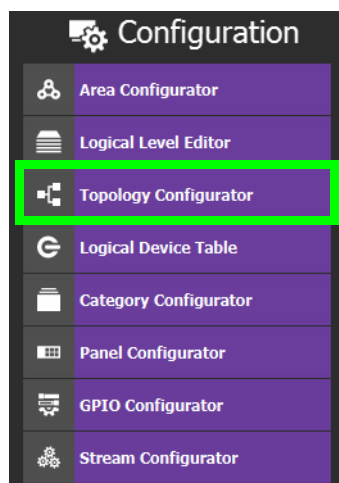

The Topology Configurator appears. The Topology Configurator comprises three sections. The left hand column has a list of bubbles, representing the device groups, such as cameras, routers, and monitors. You drag these onto to the Topology (middle column) and create connections between them. Then, you can configure the properties for the Device Groups in the **Property Editor** (right-hand column).

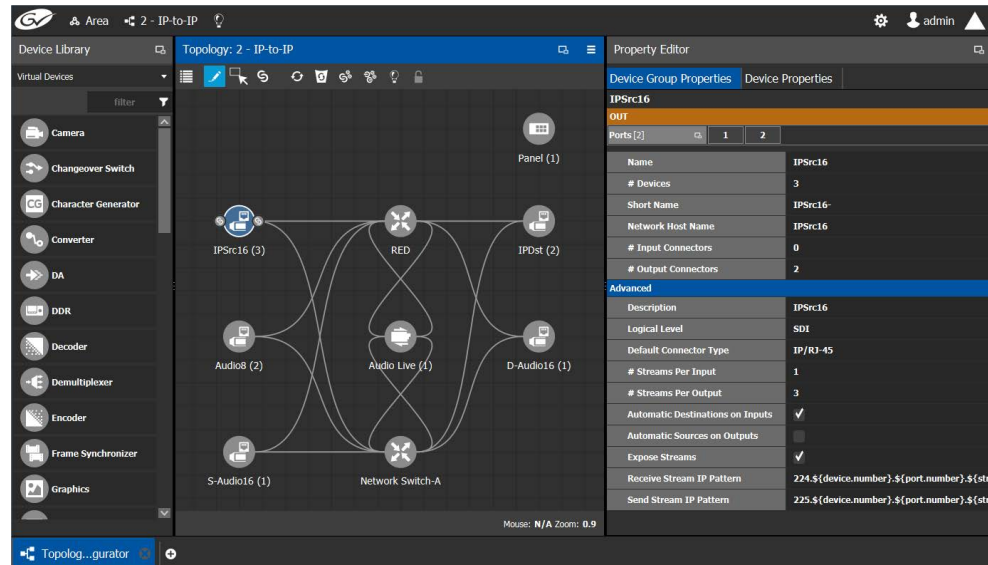

If an Area is open, the Topology Configurator opens in that area. You can switch areas from anywhere in GV Orbit Control. See [Selecting an Area](#), on page 23.

Access Permissions





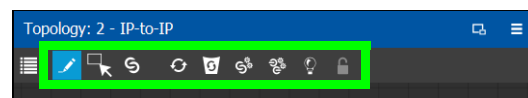

Access permissions to the Topology Configurator vary according to role. Only users who are assigned to the Administrators or Engineers role can View, Edit, and Delete topologies and device properties. Operators have the right to view topologies and device properties. Maintenance staff and Guests have no access. See [Viewing Permissions by Role](#), on page 304.

Topology Configurator Menu



The Topology Configurator has the following menu options.

Icon	Description
	Edit Use this editing mode to select a device on the topology to edit its properties. See Defining Device Properties , on page 61.
	Select Use this editing mode to select one or more devices on the topology (by drawing a square with your mouse cursor) to move the selected devices around on the topology as a group, or to delete them. Press the <Ctrl> key to temporarily enable this option.

Icon	Description
 Link	Use this editing mode to connect a device's sources to the destinations of another device. See Methods to Link Devices in a Topology , on page 53. This editing mode is also used to break the connection between two devices. See Deleting the Connection Between Device Groups , on page 60.
 Refresh	Reloads the Topology's contents. See Refreshing the Topology , on page 42.
 Delete	Remove the currently-selected device from the topology. See Deleting a Device From a Topology , on page 65.
 Quick Connect	This automatically connects the unconnected ports of devices on the topology. See Methods to Link Devices in a Topology , on page 53 and Using Quick Connect to Link all Devices in a Topology , on page 53.
 Quick Config	This sets the configuration of the selected devices on the topology. See Using Quick Config , on page 50.
 Deactivate / Active	Activating a topology makes GV Orbit Control connect to and activate all drivers to devices in the topology. This is important for GV Orbit Control to learn a device's current configuration. See Activating a Topology , on page 66 and Making an Active Topology Inactive , on page 67.
 Lock / Unlock	Lock a Topology to prevent you from inadvertently making edits on an active topology. See Unlocking / Relocking a Topology , on page 69 and Locking an Unlocked Topology , on page 70.

How to Identify if a Device Bubble is Selected or Not

A device bubble has the following selection states.



Description	Device Bubble State	Device properties are shown in the Property Editor
Gray, no white circle	Not selected	
Gray with white circle	Selected	
Blue with white circle	Selected	•

Refreshing the Topology

If you have added a lot of devices to a topology or made many modifications to it, you may need to refresh the Topology. You can refresh topology regardless of whether it is active or inactive.

To refresh the Topology

- 1 Open a topology in the Topology Configurator.

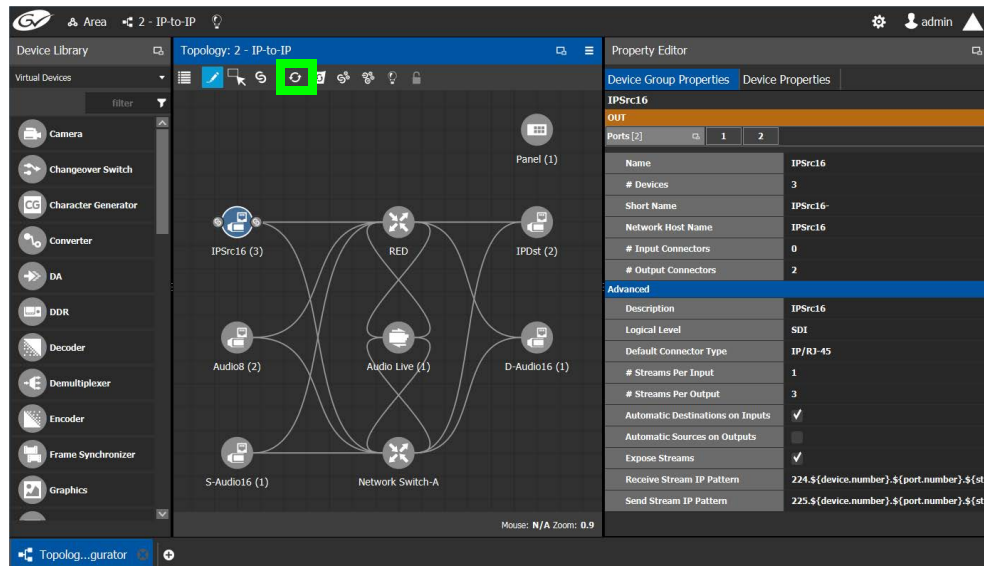

- 2 Click the Refresh button at the top of the interface.
The topology is inaccessible during the brief time it takes to refresh the window.

Viewing the Topology in Full Screen Mode

By default, the selected topology is displayed in the center of the Topology Configurator task. The devices are displayed on the left and the **Property Editor** is displayed on the right.

To view the topology in fullscreen mode

- 1 Open GV Orbit Control Stage. See [Navigating Back to Stage](#), on page 10.
- 2 Select the required Area. See [Selecting an Area](#), on page 23.

- 3 Select the required topology. See [Selecting a Graph](#), on page 25.

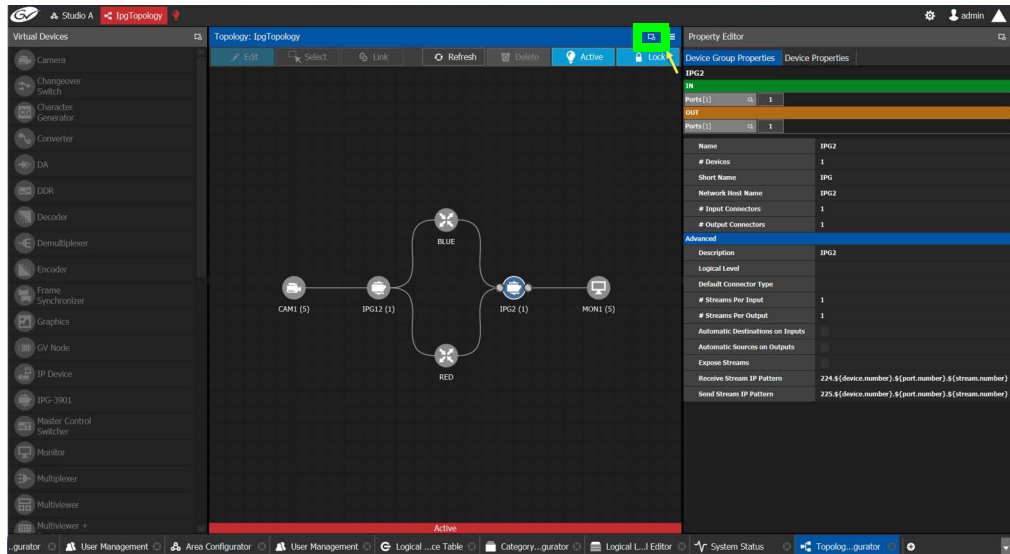

- 4 Click the Fullscreen toggle button at the top of the interface.
The Topology expands across all three columns in the Topology Configurator.

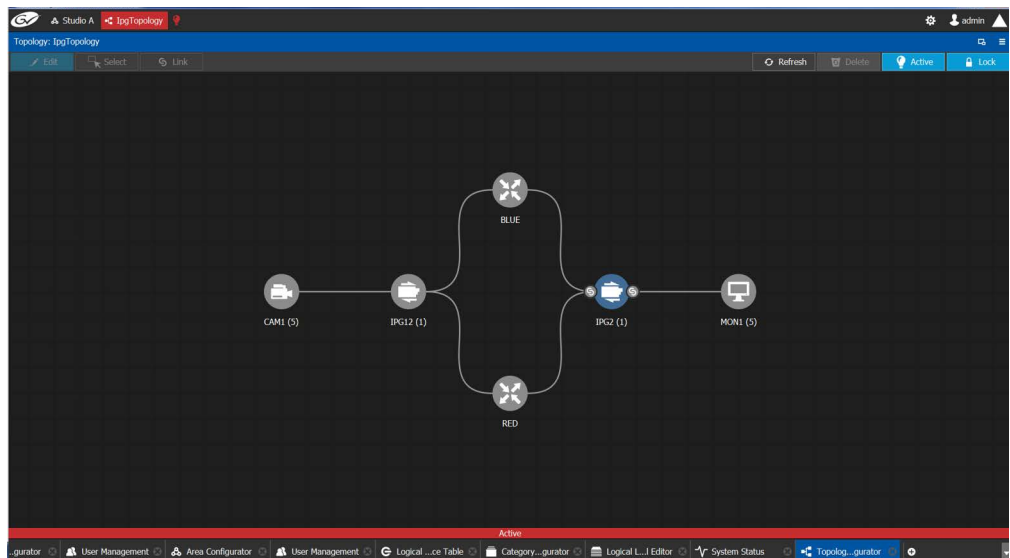

TIP

To zoom and center the topology view:

- click the Refresh button.
- double-click an empty space.

To return to default mode

- 1 When the Topology is in fullscreen mode, click Fullscreen to toggle the display back to the default mode.

Adding Devices to a Topology

By adding devices to a topology, you are making a representation in GV Orbit Control of the real world equipment you are using, and the physical interconnections made between this equipment.

There are two types of devices in GV Orbit Control.

- **Virtual Devices:** These are devices that GV Orbit Control does not need to know any of the device's configuration parameters in order to use the device. Therefore, the device can be offline when configuring it in GV Orbit Control. See [To add a Virtual Device to a topology](#), on page 44. Certain devices may require advanced configuration procedures; see [Special Device Configuration Tasks](#), on page 161.
- **Discovered:** These are devices that GV Orbit Control needs to know the device's configuration parameters in order to know which of the device's spigots have been configured as sources or destinations, the levels, and so on. These devices must be online when configuring them in GV Orbit Control. For more information about discovered devices, see [About Discovered Devices](#), on page 45.

To add a Virtual Device to a topology

Certain Virtual Devices require advanced configuration procedures; see [Special Device Configuration Tasks](#), on page 161 for more information about the specific device you are adding to the Graph, if necessary.

- 1 Select the required Area. See [Selecting an Area](#), on page 23.
- 2 Select the required topology. See [Selecting a Graph](#), on page 25.
- 3 The topology must be currently:
 - Activated (see [Activating a Topology](#), on page 66).
 - Unlocked (see [Unlocking / Relocking a Topology](#), on page 69).
- 4 From the **Device Library**, **Virtual Device** on the left, select **Virtual Devices** from the drop-down list.

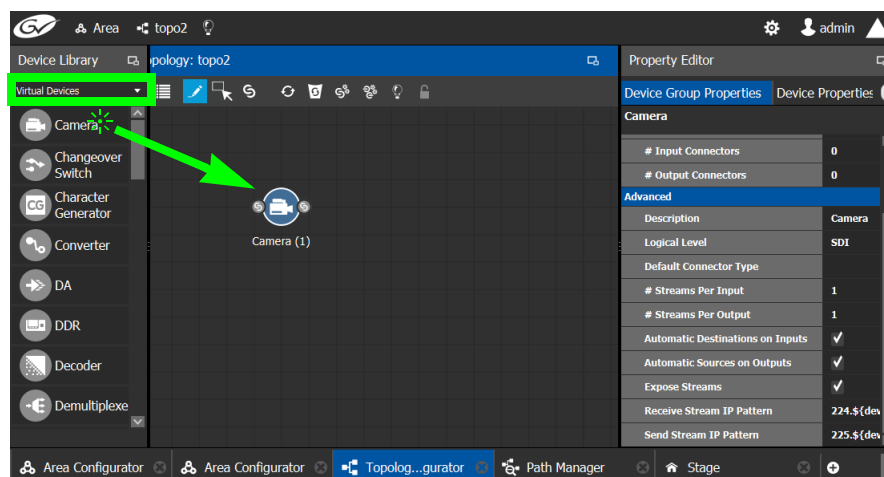

- 5 From the **Device Library**, **Virtual Device**, find the device that represents a piece of equipment you want to control: select the device bubble and drag it into position on the Topology and release the mouse button.

Initially, the device bubble represents a single device, such as a single camera. However, a bubble is a device group that can represent one or more devices. See [To name a device and set the number of devices in the group](#), on page 45.

- 6 Repeat [step 5](#) to and the following procedure ([To name a device and set the number of devices in the group](#), on page 45) until you have added all the required devices to the topology.

To name a device and set the number of devices in the group

A device group is a collection of devices of the same type that can be configured together. All bubbles in a Topology are automatically device groups with the exception of the following devices: IPVU, IPG-3901, IPG-4901, IQMIX, IQUCP, UCP-3901, MV-820-IP, Kahuna-IP, NMOS devices, Audio Live, IQAMD, Network Switch, Router, and GV Node.

- 1 Click on the name of the device underneath the bubble to create a device group. The Device Group configuration window appears.

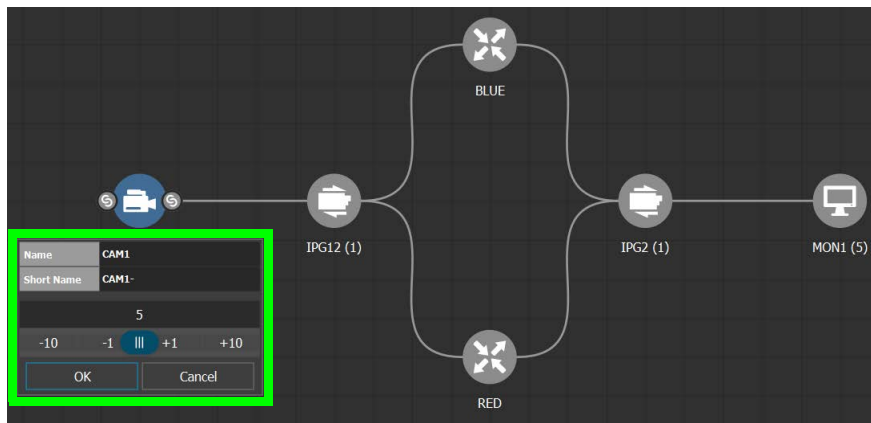

- 2 Enter meaningful names to identify the device group in the **Name** and **Short Name** fields.

In this case, the Camera device group is named CAM1 to identify the cameras controlled by Controller 1. These parameters can also be set in the **Property Editor**.

- 3 Use the plus and minus buttons to enter the number of device instances are in the device group.
- 4 Click **OK**.

Each device instance is shown and can be individually configured in the **Property Editor**, under **Devices**, by clicking an instance.

In the above example, five monitors, two IPGs, two network switches, and five cameras have been added to the Topology.

About Discovered Devices

There are two different types of discovered devices:

- NMOS devices discovered with IS-04, that can be senders, receivers or both. For more information, see [Adding NMOS Devices to a Topology](#), on page 208.
- Grass Valley devices discovered with GVOP; see below for a list of these devices.

GVOP Devices

In order to use discovered GVOP devices in GV Orbit Control, the discovered devices must first be configured through the RollCall. GV Orbit Control needs to know the device's configuration parameters in order to know which of the device's spigots have been configured as sources or destinations, the levels, and so on. These devices must be online when configuring them in GV Orbit Control.

The following Devices Use GVOP to be discovered by GV Orbit Control.

Discovered Device Type	For more information, see
IPG-3901 / IPG-4901	Configuring an IPG-3901 / IPG-4901 Device , on page 174
IPVU	Configuring an IPVU Device , on page 180
IQMIX	Configuring an IQMix, IQUCP, or UCP-3901 Device , on page 183
IQUCP	
UCP-3901	
MV-820-IP	
Kahuna-IP	Configuring a Kahuna IP Production Switcher Device , on page 198
Audio Live	Configuring a Device that Supports Audio Breakaway/Shuffling such as Audio Live , on page 252
IQAMD	Configuring an IQAMD40 Device , on page 265
Other devices that use GVOP for Configuration	These are devices that can be configured through RollCall.

When the device uses GVOP for Configuration:

- Logical sources/destinations are created using the device spigot streams (Video, Audio, ANC). There is a logical source for each sender spigot and a logical destination for each receiver spigot.

Logical sources/destinations for GVOP devices are created using the audio channels from the spigot streams. The device's spigot configuration must have the **Num Audio Flows** configuration parameter that allow the use of 1, 2 or 4 audio streams.

The device's **Num Audio Flows** configuration parameter is configured on the device's Spigot page by connecting to the card's configuration with RollCall. See the device's documentation to see if this parameter is supported and how to set it.

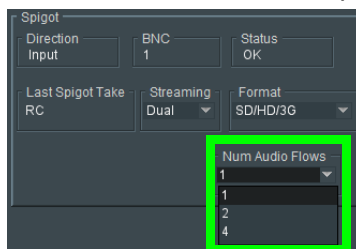

This spigot configuration allows the use of 1, 2 or 4 audio flows where the audio channels count in GV Orbit Control is accordingly adjusted. The 16 audio channels from

the automatic logical sources / destinations are accordingly created using the multi audio streams / flows set in the card's configuration.

Num Audio Flows set in the GVOP card's Spigot	Effect in GV Orbit Control
1	<p>There is 1 audio stream for the spigot with 16 audio channels which are represented in GV Orbit Control by the AES67-16 logical level. In the GV Orbit Control GVOP device Properties, the following streams are available:</p> <p>1: SDI, SMPTE ST 2022. In the Logical Device Table, this is represented by the SDI column.</p> <p>2: Video, SMPTE ST 2110-20. In the Logical Device Table, this is represented by the V column.</p> <p>3: Audio AES67-16, SMPTE ST 2110-30. In the Logical Device Table, this is represented by the A1 to A16 columns.</p> <p>7: Ancillary, SMPTE ST 2110-40. In the Logical Device Table, this is represented by the ANC column.</p>
2	<p>There are 2 audio streams for the spigot; each stream has 8 audio channels which are represented in GV Orbit Control by the AES67-8 logical level. In the GV Orbit Control GVOP device Properties, the following streams are available:</p> <p>1: SDI, SMPTE ST 2022. In the Logical Device Table, this is represented by the SDI column.</p> <p>2: Video, SMPTE ST 2110-20. In the Logical Device Table, this is represented by the V column.</p> <p>3: Audio AES67-8, SMPTE ST 2110-30. In the Logical Device Table, this is represented by the A1 to A8 columns.</p> <p>4: Audio AES67-8, SMPTE ST 2110-30. In the Logical Device Table, this is represented by the A9 to A16 columns.</p> <p>7: Ancillary, SMPTE ST 2110-40. In the Logical Device Table, this is represented by the ANC column.</p>

Num Audio Flows set in the GVOP card's Spigot	Effect in GV Orbit Control
4	<p>There are 4 audio streams for the spigot; each stream has 4 audio channels which are represented in GV Orbit Control by the AES67-4 logical level. In the GV Orbit Control GVOP device Properties, the following streams are available:</p> <p>1: SDI, SMPTE ST 2022. In the Logical Device Table, this is represented by the SDI column.</p> <p>2: Video, SMPTE ST 2110-20. In the Logical Device Table, this is represented by the V column.</p> <p>3: Audio AES67-4, SMPTE ST 2110-30. In the Logical Device Table, this is represented by the A1 to A4 columns.</p> <p>4: Audio AES67-4, SMPTE ST 2110-30. In the Logical Device Table, this is represented by the A5 to A8 columns.</p> <p>5: Audio AES67-4, SMPTE ST 2110-30. In the Logical Device Table, this is represented by the A9 to A12 columns.</p> <p>6: Audio AES67-4, SMPTE ST 2110-30. In the Logical Device Table, this is represented by the A13 to A16 columns.</p> <p>7: Ancillary, SMPTE ST 2110-40. In the Logical Device Table, this is represented by the ANC column.</p>

In the GV Orbit Control GVOP device Properties, the number, type of streams, and AES67 Logical Level are updated in real time according to the card's settings made in RollCall. For example, this screen shows the Properties for a card where the card's **Num Audion Flows** parameter configured to 1 and as a consequence, the level for the audio stream is shown as AES67-16.

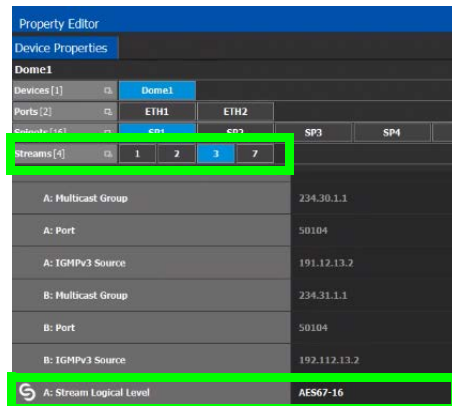

In the Logical Device Table, the GVOP device reflects the configuration settings, where there is only one audio stream.

Name	Description	#	SDI	V	A	ANC
Spigot1	Dome1 Spigot1	516		Dome1 Spigot1 Dome1	Dome1 Spigot1 Dome1	Dome1 Spigot1 Dome1

To add a Discovered device to a Topology, see below. See also [AES Logical Levels that are used for IP Audio Streams](#), on page 255.

To add a Discovered Device to a Topology

Discovered devices typically require advanced configuration procedures; see [Special Device Configuration Tasks](#), on page 161 for more configuration information about the specific device you are adding to the Graph.

Adding a discovered device to a topology

- 1 Select the required Area. See [Selecting an Area](#), on page 23.
- 2 Select the required topology. See [Selecting a Graph](#), on page 25.
- 3 The topology must be currently:
 - Activated (see [Activating a Topology](#), on page 66).
 - Unlocked (see [Unlocking / Relocking a Topology](#), on page 69).
- 4 From the **Device Library**, on the left, select **Discovered** from the drop-down list. In the example below, an IQMix was discovered on the network.

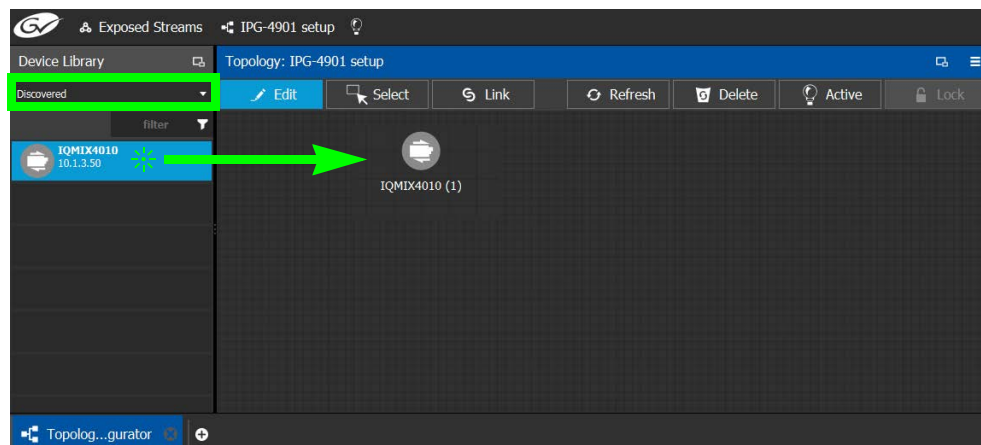

- 5 From the **Device Library**, **Discovered** find the device that you want to control: select the device bubble and drag it into position on the Topology and release the mouse button.

The device pulled from the **Device Library**, **Discovered** becomes grayed out and another instance of the same device instance cannot be added again to the Topology. However, multiple device instances found in the Device Library can be used to create a device group.

- 6 To create a device group:
 - a From the **Device Library, Discovered**, find the device that you want to control: select the device bubble and drag it into position on the Topology and release the mouse button.
 - b From the **Device Library, Discovered**, find another identical device that you want to control: select the device bubble and drag it on top of the first device instance already on the Topology and release the mouse button.

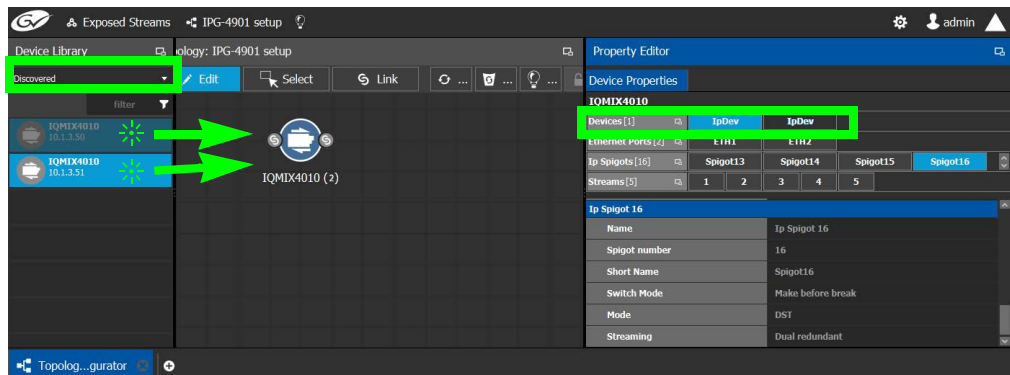

The two device instances are shown and can be individually configured in the **Property Editor**, under **Devices**, by clicking an instance.

- 7 Click on the name of the device underneath the bubble to name the device or device group.

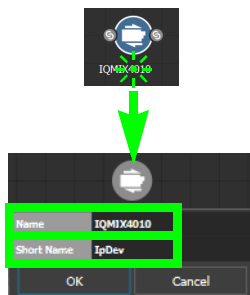

These parameters can also be set in the **Property Editor** when the device bubble is selected.

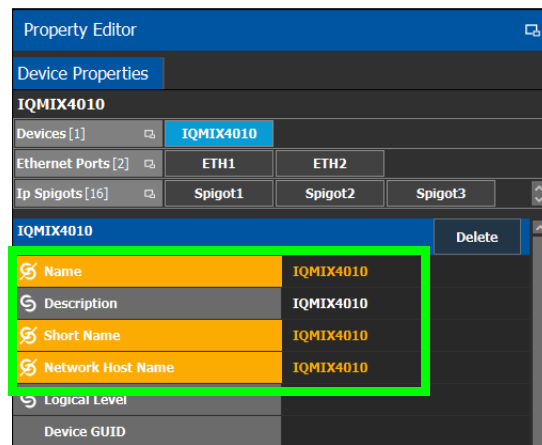

Using Quick Config

Quick Config is used to make bulk configuration changes to the selected devices. See [How to Identify if a Device Bubble is Selected or Not](#), on page 41. It can:

- Change a device’s logical level.
- Expose or un-expose the device’s streams.

Switches allow the changes to apply only to IP streams, SDI streams, inputs, or outputs. For example, Quick Config can be used multiple times: the first time to set the logical level for the device’s inputs, and then a second time to set another logical level for the device’s outputs.

To set the Quick Config options for the selected devices

- 1 Select the devices on the Topology you want to configure.
- 2 Click  in the Topology Configurator’s toolbar.

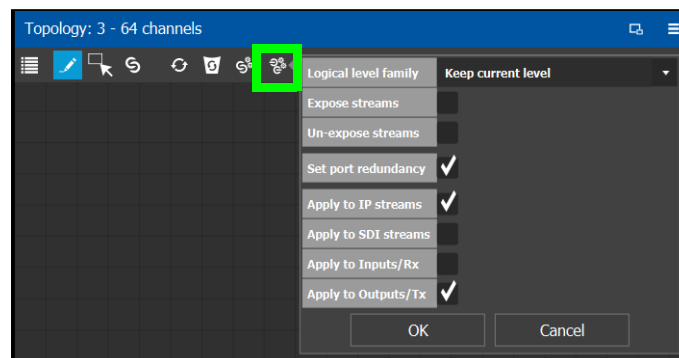

- 3 Set the following options.

Parameter	Description
Logical level family	Select the logical level to assign to the device’s source and destination streams. See also Duplicating a Logical Level , on page 33. Keep current level: leaves the device’s currently-assigned source and destination logical levels untouched.
Expose streams un-expose streams	Only certain devices support this property. When Expose Stream is set, it displays the streams for this device in the Logical Device Table. See Logical Device Table Tasks , on page 72.
Set port redundancy	Certain third-party devices that support port redundancy are not automatically recognized by GV Orbit Control to support redundancy. When devices have been configured with two or more ports, set this option to make the ports redundant in GV Orbit Control. See Setting Port Redundancy for Many Devices at Once , on page 51.
Apply to IP streams	Set to apply the above settings to IP network connections between devices.
Apply to SDI	Set to apply the above settings to SDI connections between devices.
Apply to Inputs/Rx	Set to apply the above settings to device destinations.
Apply to Outputs/Tx	Set to apply the above settings to device sources.

4 Click **OK**.

Setting Port Redundancy for Many Devices at Once

Redundancy associates a port with another port to create a redundant network traffic flow path for failover protection. The associated port will not be available to carry other traffic. For example, this is a requirement of a SMPTE ST 2022-7 network topology. See also [Configuring Network Switch Redundancy to Support SMPTE ST 2022-7](#), on page 230.

Note: This feature is to only be used with third-party devices.

Certain third-party devices that support port redundancy are not automatically recognized by GV Orbit Control to support redundancy. For such devices, once they have been configured with two or more input / output connectors, use the **Set port redundancy** option in **Quick Config** (see [Using Quick Config](#), on page 50) to make the ports redundant in GV Orbit Control. When completed, the **Redundancy Port** parameter in the **Device Properties** for *in / out 1* is *in / out 2* and the **Redundancy Port** parameter for *in / out 2* is *in / out 1*. If there are 4 ports, then the **Redundancy Port** parameter for *in / out 3* is *in / out 4* and the **Redundancy Port** parameter for *in / out 4* is *in / out 3* and so on.

For more information about **Device Properties**, see [Defining Device Properties](#), on page 61.

Use other **Quick Config** options to focus the redundancy on the required ports and port direction. For example, to make the selected device's output IP streams redundant, set the Quick Config as shown below.

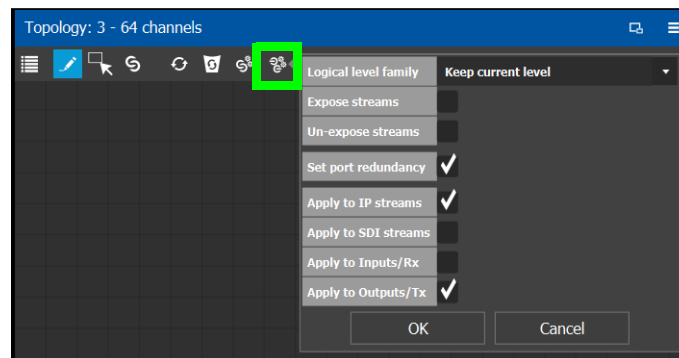

Once these devices have been configured, use the Stream Configurator to set the IP address for a large number of devices in an efficient way. See [Stream Configurator Tasks](#), on page 152.

Example of how to set port redundancy for many devices at once

This procedure is an example for the following scenario:

- 100 IP analog-to-digital audio devices have been connected to the network switches with redundant connections.
- Each audio device supplies IP outputs for 16 channels of AES67 audio.

This example makes the IP output connections 1 and 2 redundant for each audio device in a device group of 100 generic IP Devices.

- 1 Open the Topology Configurator. See [Accessing the Topology Configurator](#), on page 39.

- 2 From the Device Library, drag an **IP Device** onto the Topology Configurator. See [To add a Virtual Device to a topology](#), on page 44.
- 3 Select the **IP Device**. See [How to Identify if a Device Bubble is Selected or Not](#), on page 41.
- 4 Set the device group's properties as follows (see [Defining Device Properties](#), on page 61 and [Device Properties Definitions](#), on page 64):
 - Set the number of output connections in **# Output Connections** to **2**.
 - Set the logical levels for the device in **Logical Level** to **AES67-16**.
 - For a SMPTE ST 2110 device with three output streams, set the number of streams in **# Streams Per Output** to **3**.
 - Set the logical levels for each of these streams to video, audio, and ancillary found under the individual stream properties.
 - Set the IP address for each stream (video, audio, and ancillary) found under the individual stream properties.
- 5 Set the number of **IP Device** instances to 100 and set a name for the devices. See [To name a device and set the number of devices in the group](#), on page 45.
- 6 Click  in the Topology Configurator's toolbar while the device group is selected. See [To set the Quick Config options for the selected devices](#), on page 50.
- 7 Set the following Quick Config options:
 - Set port redundancy
 - Apply to IP streams
 - Apply to outputs / Tx
- 8 Click **OK**.

When complete, the **Redundancy Port** parameter in the **Device Properties** for *out 1* is *out 2* and the **Redundancy Port** parameter for *out 2* is *out 1* for all device instances. The IP address for these devices can be efficiently set with the Stream Configurator. See [Stream Configurator Tasks](#), on page 152.

Methods to Link Devices in a Topology

Once two or more devices have been added to the Topology Configurator (see [Adding Devices to a Topology](#), on page 44), devices can be linked together using the following methods. Using one method does not prevent you from using another method in the future.

Linking Method	Description	See Procedure
Quick Connect	Automatically connects all unconnected ports of devices currently in the Topology Configurator. Quick Connect options can limit automatic connections by stream, source, or destination type.	Using Quick Connect to Link all Devices in a Topology , on page 53.
Manual Linking	Create the links between devices manually. Manual linking allows precise control over link parameters. You must also set the link's physical connection parameters (sources and destinations) for each link.	<ol style="list-style-type: none"> Manually Linking the Devices in a Topology, on page 55. Manually Setting the Link's Physical Connection Parameters (Sources and Destinations), on page 57.

Using Quick Connect to Link all Devices in a Topology

Quick Connect automatically connects all unconnected ports of:

- All devices currently in the Topology Configurator when no devices are selected.
- The currently selected devices in the Topology Configurator.

See [How to Identify if a Device Bubble is Selected or Not](#), on page 41.

When necessary, it reads the device's configuration to learn:

- Which ports / spigots have been configured as sources or destinations.
- The available IP ports, including control and management ports.

If a NMOS node has been added to the topology and has been configured and is working (see [Adding NMOS Devices to a Topology](#), on page 208), Quick Connect will connect the NMOS node's management ports.

Quick connect also automatically connects the link's physical connection parameters (sources and destinations) for each link.

Once more devices have been added to the topology, or if a link has been cut, Quick Connect can be run again to automatically connect those devices. Quick Connect will ignore pre-existing connections between devices.

Quick Connect has an option to automatically create sources and destinations for SDI inputs and outputs. SDI inputs are connected to Camera device groups, and outputs are connected to Monitor device groups. As a result, these SDI Camera and Monitor devices become available in the Logical Device Table as the device's inputs and outputs. See [Logical Device Table Tasks](#), on page 72.

GV Orbit ControlQuick Connect is found in the Topology Configurator's toolbar.

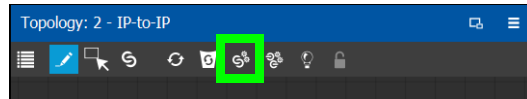

PREREQUISITES: The following must have been configured:

- If the system requires physical IP connections to be made, make sure you have at least one network switch device in your topology. If your network uses a second network switch to support redundancy (for example, to support SMPTE ST 2022-7), then you must have at least two network switch devices in your topology. See also [Configuring Network Switch Redundancy to Support SMPTE ST 2022-7](#), on page 230.
- Ensure that core devices such as those listed in [Special Device Configuration Tasks](#), on page 161 have been added to the topology using drag-and-drop from the Virtual or Discovered devices libraries and have been configured before using this tool. For example, GV Nodes, IPG-X901, IQMix, IQUCP, UCP-3901 cards, Audio Live, and Routers. See [Special Device Configuration Tasks](#), on page 161 for specific configuration information about these devices.
- Add the remaining devices to the topology. See [Adding Devices to a Topology](#), on page 44.
- The topology must be currently:
 - Activated (see [Activating a Topology](#), on page 66).
 - Unlocked (see [Unlocking / Relocking a Topology](#), on page 69).
- All devices must be currently online. That is, no device should be shown in red in the System Status. See [System Status Task](#), on page 277.
- The required logical levels have been created. See [Accessing the Logical Level Editor](#), on page 30.

Using Quick Connect

Set the Quick Connect options before using Quick Connect. See [Using Quick Config](#), on page 50.

- 1 Click  in the Topology Configurator's toolbar.

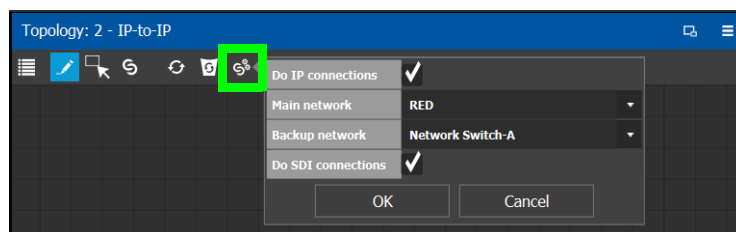

- 2 Set the following options.

Parameter	Description
Do IP connections	Set to automatically create IP network connections between devices.
Main network	Select the name of the primary switch in your network.

Parameter	Description
Backup network	If your network uses two network switches to support redundancy (for example, to support SMPTE ST 2022-7), then select the name of the secondary switch in your network. See also Configuring Network Switch Redundancy to Support SMPTE ST 2022-7 , on page 230.
Do SDI connections	Set to automatically create SDI connections between devices.

3 Click **OK**.

Manually Linking the Devices in a Topology

Once the device groups are added to the Topology, the next step is to create links between them using the Link mode which allows you to link bubbles with a touch-based device. Otherwise, if you are using a mouse and keyboard interface, you can link devices together using the following procedure while in the Edit mode as well.

To link devices or device groups in a topology

Open the required topology.

- 1 Select the required Area. See [Selecting an Area](#), on page 23.
- 2 Select the required topology. See [Selecting a Graph](#), on page 25.

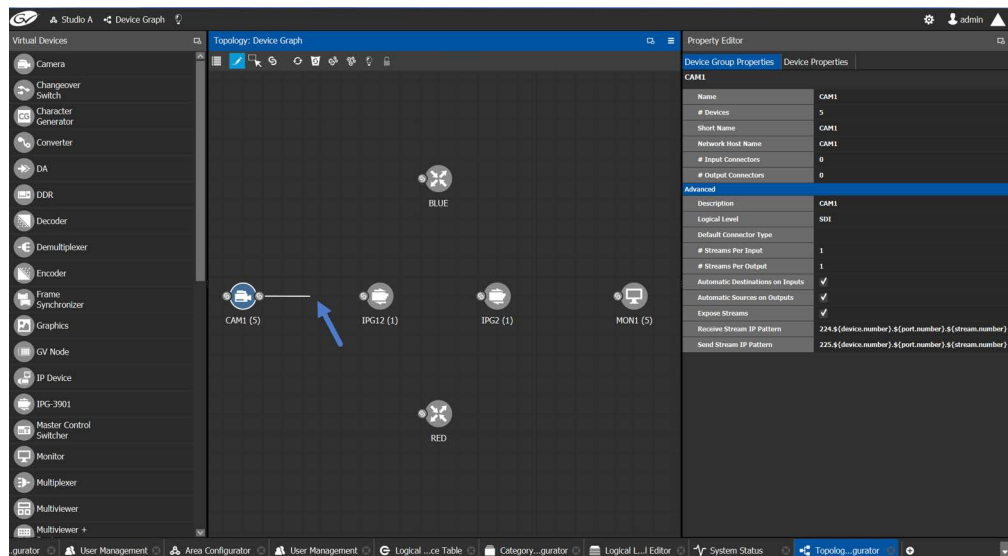

3 Click the **Link** button at the top of the interface.

4 Select the first bubble in the pair you want to connect.

When the bubble is selected, the device is highlighted in blue and both the bubble's input and outputs ports become available. Input ports are on the left side of the bubble. Output ports are on the right side of the bubble.

5 Select an input or output port on the bubble.

If the input port was selected, the output ports of all the available devices appear. If the output port was selected, the input ports of all the available devices appear.

- 6 Draw a line, with your mouse, between the ports of the two devices to make the connection between them. Or if you are using a touch-based device, the Link mode allows you to link bubbles together by dragging a bubble over others so that the connectors touch each other and then pull them apart to their final position.

Manually Setting the Link's Physical Connection Parameters (Sources and Destinations)

When a link is selected, the **Physical Connection Table** appears. It is in this table where you create the connections between device ports. When you add devices to a Topology and you then link two devices, you are indicating that the two devices in two groups are virtually connected. Therefore, you need a place to specify how these devices are actually connected. This is achieved through the Physical Connections Table. It is in this table where you will actually specify that port1 of device1 that is part of group1 is connected physically with port1 of device1 of group2, for example.

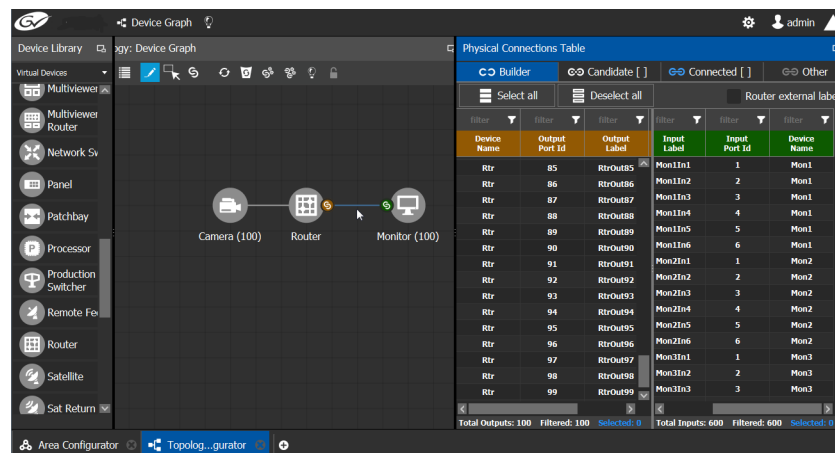



To make a connection, you must start in the Builder tab, and then complete the action in the Candidate tab.

The **Physical Connection Table** uses connection icons as follows.

Icon	State (status)	Action
	The stream is ready to be connected as it has been selected in the Builder tab.	—
	The stream is connected.	Connect: make the connection between the source and destination devices.
	—	Disconnect: break the connection between the source and destination devices.

The **Physical Connection Table** uses port type icons as follows. A source's output port type must be linked to the same input port type at the destination.

Port Type Icon	Description
 SDI	The connection type is SDI.
 IP	The connection type is IP.
 MADI	The connection type is MADI.

In the **Physical Connection Table**, more than one table row can be selected at a time; to add to a selection, use *Shift* or *Ctrl* to select a range of table rows or to add another row to the selection.

Builder Tab

The Builder tab shows all the outputs and the inputs available for connections. The output streams are shown on the left and the inputs are shown on the right for the selected link. By selecting streams in the Builder tab makes them available in the Candidate tab where they are then linked. For extra information about an input or output, set **Router external labels**. The Router external labels are only available for router ports and not all device ports.

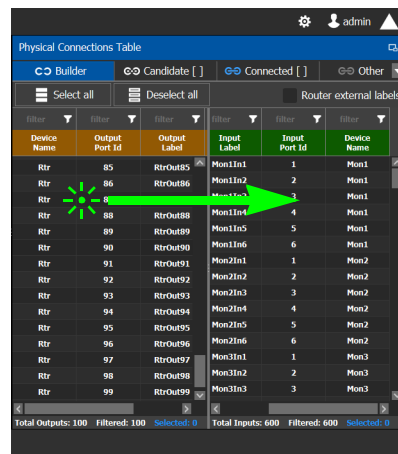

To associate a device's output stream to another device's input

- 1 Select one or more source output stream table rows that you want to link to destination's input.
- 2 Drag the source output stream table rows onto the destination input(s).
The selected items become available in the Candidate tab.

You can bypass the Candidate tab as follows: you select all your destination, and all your sources and then with your right mouse button held down you drag the destinations over the sources. With this method, the only way to review your connections is by going into the Connected tab and disconnecting the wrong/unwanted ones.

Candidate Tab

Once a device's output stream has been associated to another device's input in the Builder tab, you can review these associations to then select the ones you want to link together.

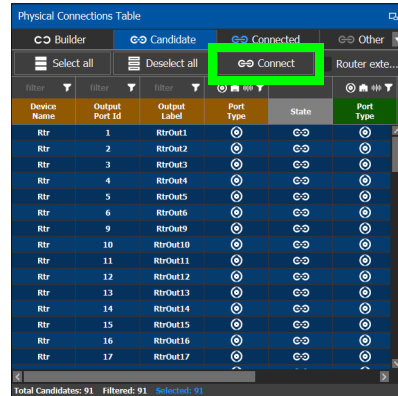

To link a device's output stream to another device's input

- 1 Select one or more table rows that you want to link the source's output stream to the destination's input.
- 2 When satisfied with your selection, click Connect at the top of the table.

Connected Tab

This tab shows the currently linked streams between the source's output and the destination's input. Links can be disconnected in this tab.

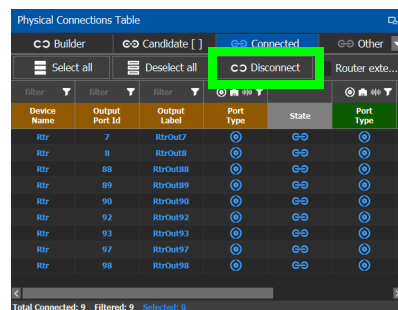

To disconnect a device's output stream from another device's input

- 1 Select one or more table rows that you want to disconnect the source's output stream to the destination's input.
- 2 When satisfied with your selection, click Disconnect at the top of the table.

Other Tab

This tab will show you all the other connections that a device's ports has on another links. For example, you have device1 with 20 ports, 10 are connected to device2 and 10 to device3. You select the first link and you connect the 10 ports. You select the second link on the Other tab you will see the first 10 ports that you connected.

Deleting the Connection Between Device Groups

To delete the connection between devices

Open the required topology.

- 1 Select the required Area. See [Selecting an Area](#), on page 23.
- 2 Select the required topology. See [Adding Devices to a Topology](#), on page 44.

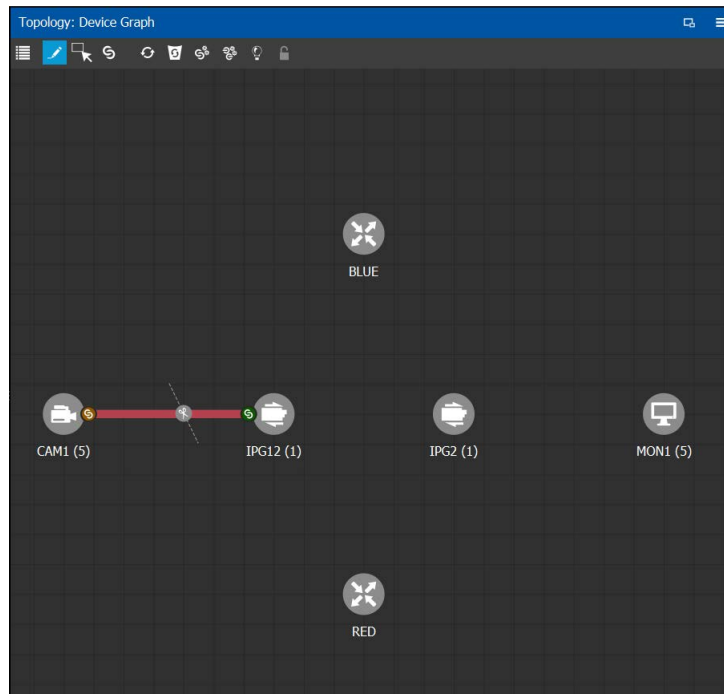

- 3 Select the **Link** button at the top of the interface.
- 4 Draw a line across the connection.
The scissor icon appears on the line and the link turns red.
- 5 Release the mouse.
The connection link is removed.

Defining Device Properties

You set the parameters for the selected device in the **Property Editor**.

- The configuration parameters for most devices is intuitive and no further explanation is required. See [Device Properties Definitions](#), on page 64 for a primer.
- The configuration of certain devices requires advanced knowledge; see [Special Device Configuration Tasks](#), on page 161 for more information about these devices.

Inheritance of Property Values from the Device Group Properties Tab

Certain parameter values in the **Device Properties** tab inherit their values from the corresponding parameter values in the **Device Group Properties** tab. This allows you to configure common parameters for a large number of devices at once with a default value.

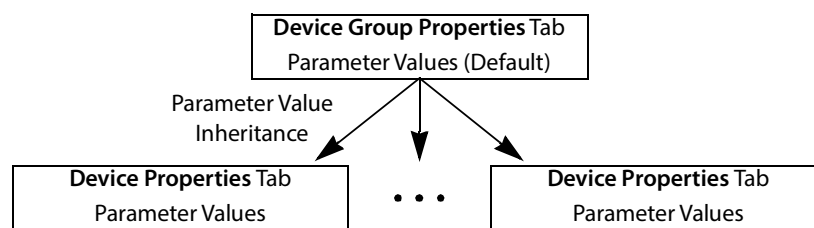

When you change the value of a parameter in the **Device Properties** tab such that it is now different from the corresponding value set in the **Device Group Properties** tab, the parameter will be displayed with an orange background. This is shown below.

The screenshot shows the "Property Editor" interface. The "Device Properties" tab is selected and highlighted in green. The "Slot Number" parameter is highlighted in orange. Two callout boxes with arrows point to the orange highlight and the "Slot Number" parameter name.

The parameter's value is a non-default value (indicated by the orange highlight)

Click to reset the parameter's value back to the default value set in the **Device Group Properties**

To define properties for a device

- 1 Open the required topology. See [Selecting a Graph](#), on page 25.
- 2 Select the device you want to configure.

The **Property Editor** is displayed on the right.

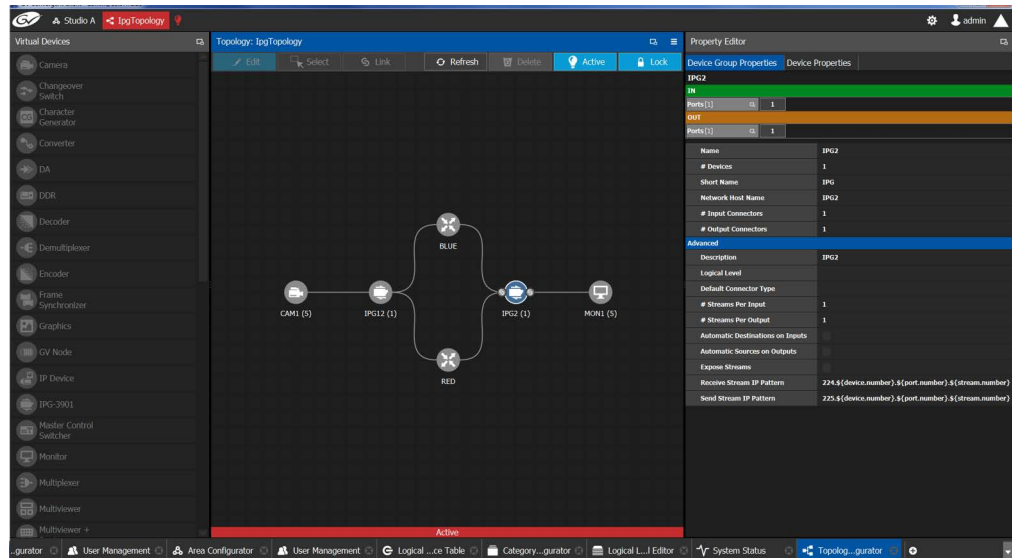

In this case, the IPG2 bubble is selected and the Device Group Properties tab is selected in the **Property Editor**.

- 3 Select the **Device Properties** tab to view the properties for the individual device. See also [Description of Common Device Properties](#), on page 162.

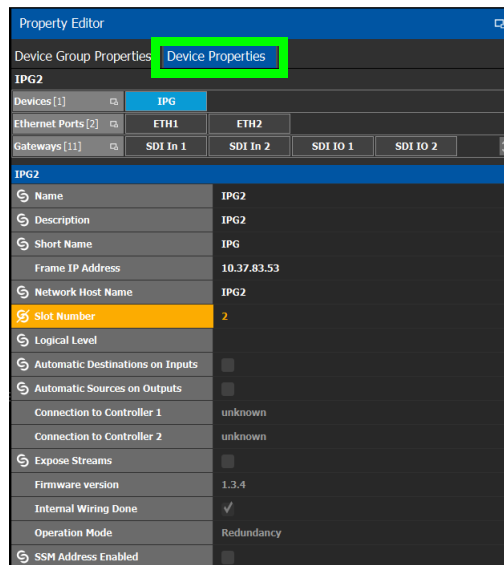

For example, for the Cameras, there is a **Device Group Properties** tab for the camera group and a **Device Properties** tab for each of the five cameras.

Camera Device Group Properties

The **Device Group Properties** tab sets the default parameter values to be passed down to each individual device in the **Device Properties** tab to save time. These default values can be overridden in the at the device level in the **Device Properties** tab.

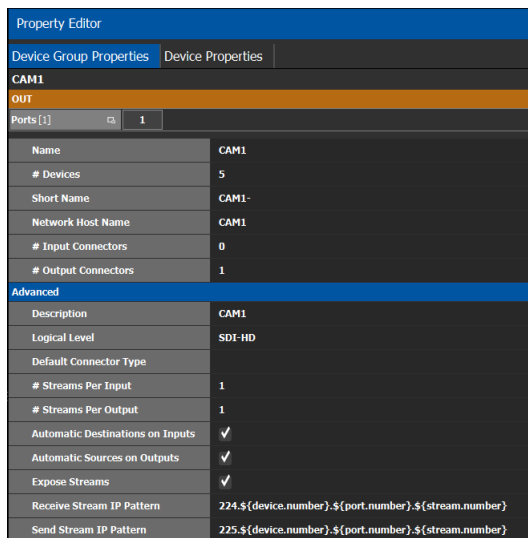

Camera Device Properties

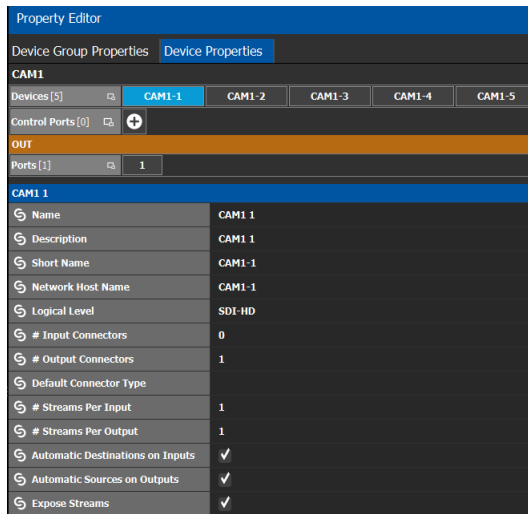

Note: All devices, device groups, and connections have properties.

Device Properties Definitions

This is a non-exhaustive overview of the device properties parameters.

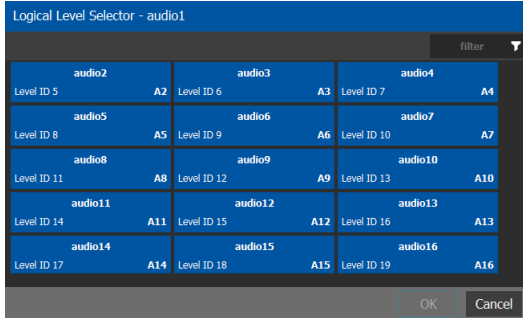
Parameter	Description
Name	The name or identifier for this device instance. The name or identifier for this input or output port.
Description	An optional description for the related input, output, or device.
Short Name	The nickname by which the input, output, or device is referred to everywhere in the system.
# Devices	The number of device instances in this device group.
Network Host Name	The hostname is the unique name by which the device is known on the network.
Logical Level	<p>The logical level for this input or output. Click to change the logical level through the Logical Level Selector.</p>  <p>Select a logical level and click OK to change the level. For more information about logical levels, to create, or modify logical levels, see Logical Level Editor Tasks, on page 30.</p>
# Input Connectors	The number of physical input port connections made to the device.
# Output Connectors	The number of physical output port connections made to the device.
# Streams Per Input	The typical number of streams available on each physical input connection.
# Streams Per Output	The typical number of streams available on each physical output connection.
# Streams	The actual number of streams available on the selected physical input / output connection.
Port Identifier	This is the generic identifier of the port within GV Orbit Control.
IP Address	The port's IP Address.

Parameter	Description
Automatic Destination Automatic Destinations on Inputs Automatic Destinations on Outputs	Set to automatically create a destination by the system for the specified streams. See also About Automatic Sources or Destinations , on page 76.
Automatic Source Automatic Sources on Outputs Automatic Sources on Inputs	Set to automatically create a source by the system for the specified streams. See also About Automatic Sources or Destinations , on page 76.
Expose Streams	When set, it displays the streams for this device in the Logical Device Table. See Logical Device Table Tasks , on page 72. The following methods are available to set or clear this parameter at once: <ul style="list-style-type: none"> • Quick Config; see Using Quick Config, on page 50. • The Stream Configurator; see Stream Configurator Tasks, on page 152
SSM Address Enabled	Shows if the source specific multicast address is enabled.
SDP	See Using SDP Parameters to Take a Stream from a non-NMOS Device to an NMOS Device , on page 216.
Redundancy Port	Associates a port with another port to create a redundant network traffic flow path for failover protection. The associated port will not be available to carry other traffic. This is usually a requirement of a SMPTE ST 2022-7 network topology. See also Configuring Network Switch Redundancy to Support SMPTE ST 2022-7 , on page 230. See also Setting Port Redundancy for Many Devices at Once , on page 51.

Deleting a Device From a Topology

You must open a topology in the Topology Configurator before you can delete it.

To delete a topology

- 1 Select the Area. See [Selecting an Area](#), on page 23.
- 2 Select the topology. See [Selecting a Graph](#), on page 25.
- 3 Select the device you want to remove.
The device is highlighted on the Topology.

4 Click **Delete**.

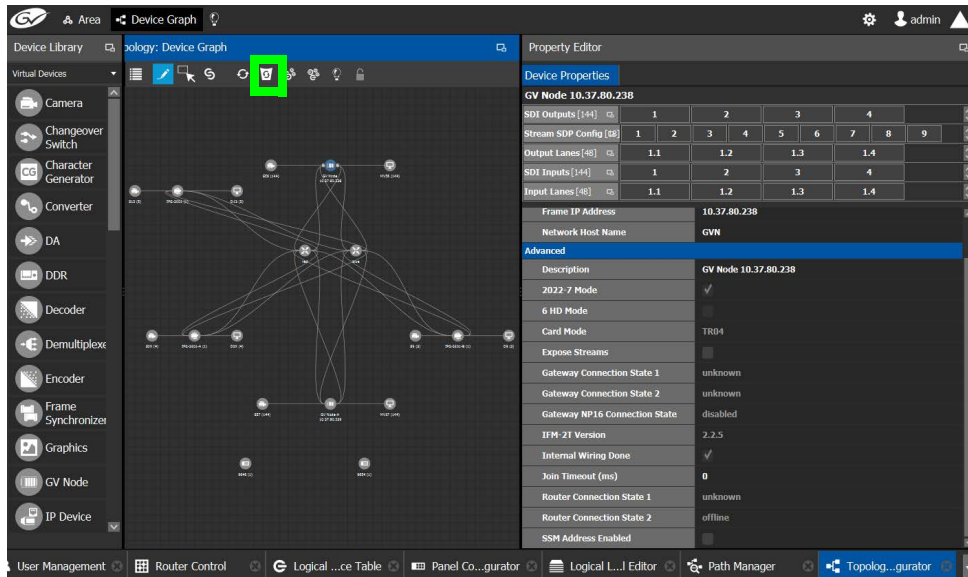

Activating a Topology

By activating a topology makes GV Orbit Control connect to and activate all drivers to devices in the topology. For example, for a GV Node it means initiating the Densité and NP0016 connections and being able to control them. By activating a topology, panels will become active and light up.

You must select a topology and open it in the Topology Configurator before you can make it active.

Note: Only one topology can be active at a time for each area.

To make a topology active

- 1 Select the required Area. See [Selecting an Area](#), on page 23.
- 2 Select the required topology. See [Selecting a Graph](#), on page 25.

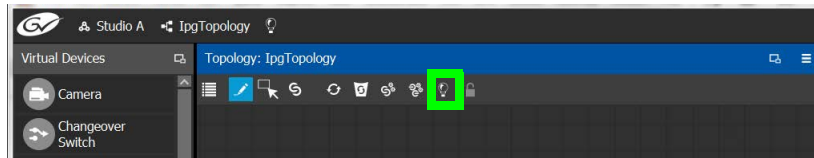

- 3 Click **Active** at the top of the Topology Configurator.
A confirmation message appears.

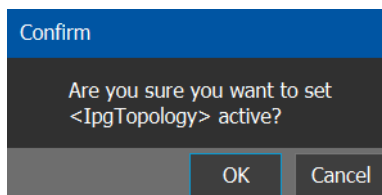

- 4 Click **OK** to continue.

The following changes occur.

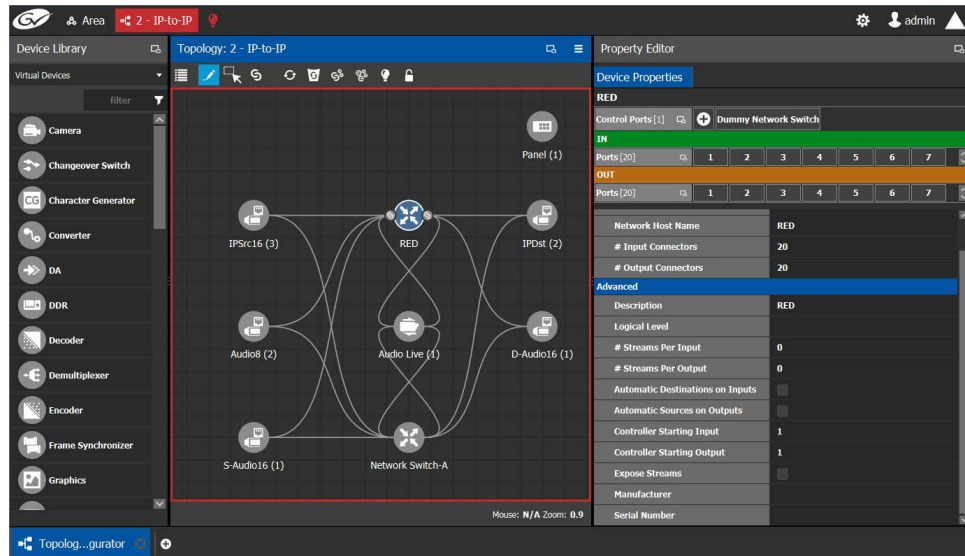

- The topology name is displayed in red at the top of the Topology Configurator.
- A red lightbulb is displayed beside the topology name.
- A red box appears around the topology.
- Active is written on the bar.
- The topology is locked.
- The red Active bar is displayed on the thumbnail for the active topology.

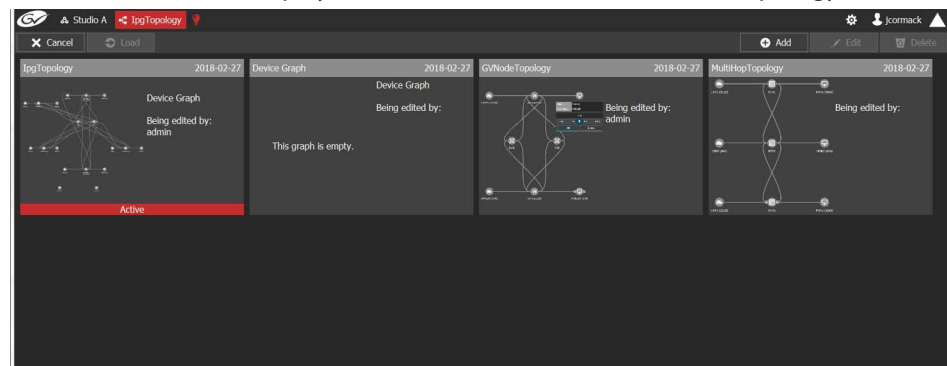

Making an Active Topology Inactive

Only one topology can be active at a time for each area. You must open the active topology in the Topology Configurator before you can make it inactive.

To make an active topology inactive

- 1 Select the required Area. See [Selecting an Area](#), on page 23.

- 2 Select the required topology. See [Adding Devices to a Topology](#), on page 44.

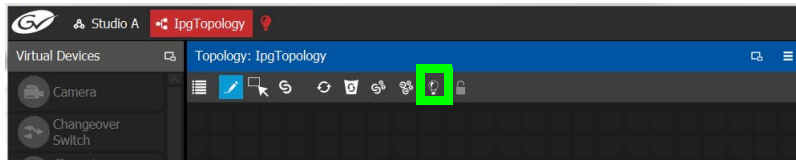

- 3 Click the **Active** button at the top of the Topology Configurator.
A confirmation message appears.

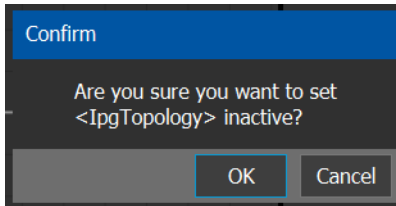

- 4 Click **OK** to continue.
The following changes occur.

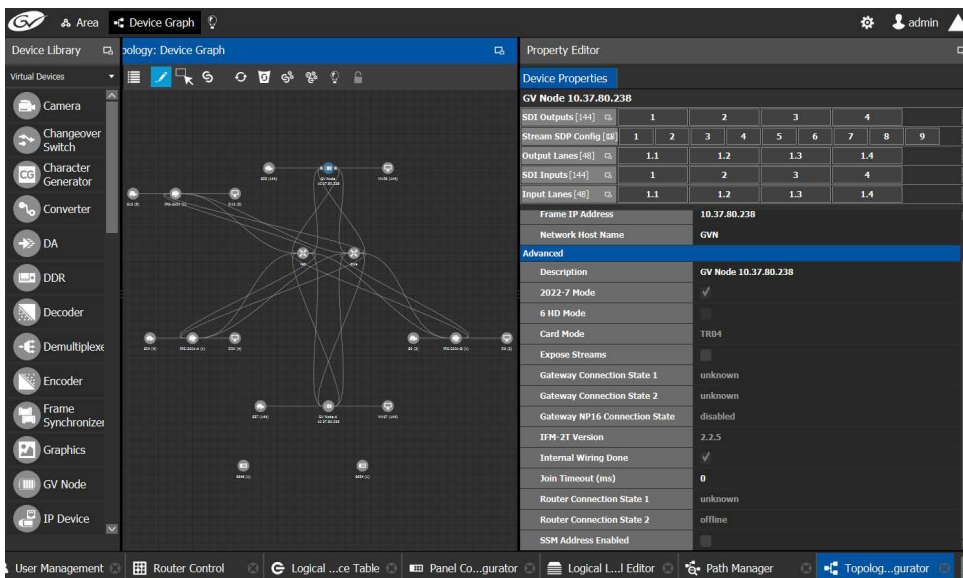

- The topology name no longer appears in red at the top of the Topology Configurator.
- The red bar no longer appears at the base of the Topology.
- The topology is unlocked.
- The red Active bar is no longer displayed on the thumbnail for the active topology in the secondary window.

Unlocking / Relocking a Topology

A topology is locked automatically when you make it active. The lock only affects the current GV Orbit Control application. If multiple users have the same topology open, then each user can lock/unlock their client to do edits; this setting is not global to all open clients.

To unlock an active topology

- 1 Select the required Area. See [Selecting an Area](#), on page 23.
- 2 Select the required topology. See [Selecting a Graph](#), on page 25.

This opens the topology in the Topology Configurator.

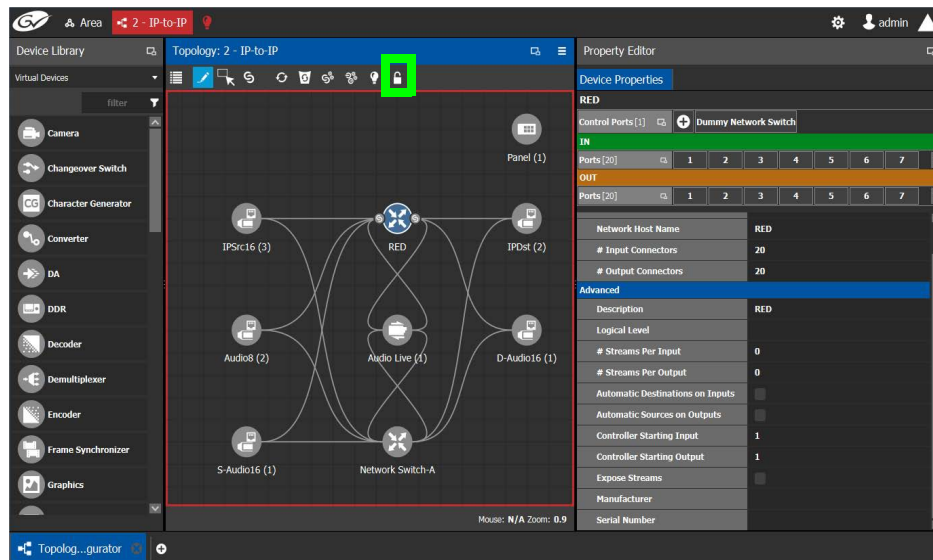

- 3 Click the **Lock** button.
A confirmation message appears.

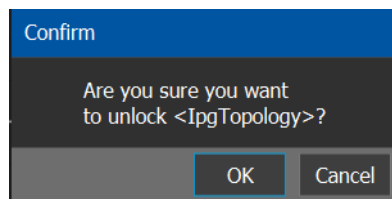

4 Click **OK** to continue.

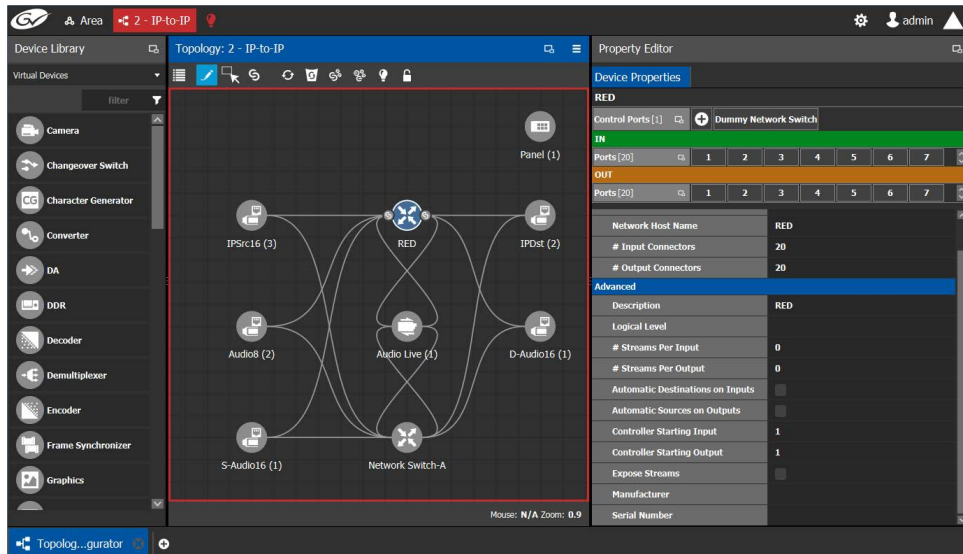

When a topology is unlocked

- The lock icon is unlocked.
- If you have Edit permissions to the Topology Configurator for the selected area, you can modify the active topology.

Locking an Unlocked Topology

It is recommended to relock an unlocked topology, when you have finished your edits. This prevents you from inadvertently making edits on an active topology, such as selecting an object and pressing delete by accident.

Note: You can only lock an unlocked active topology. Inactive topologies cannot be locked or unlocked.

To lock a unlocked active topology

- 1 Select the required Area. See [Selecting an Area](#), on page 23.
- 2 Select the required topology. See [Selecting a Graph](#), on page 25.

This opens the topology in the Topology Configurator.

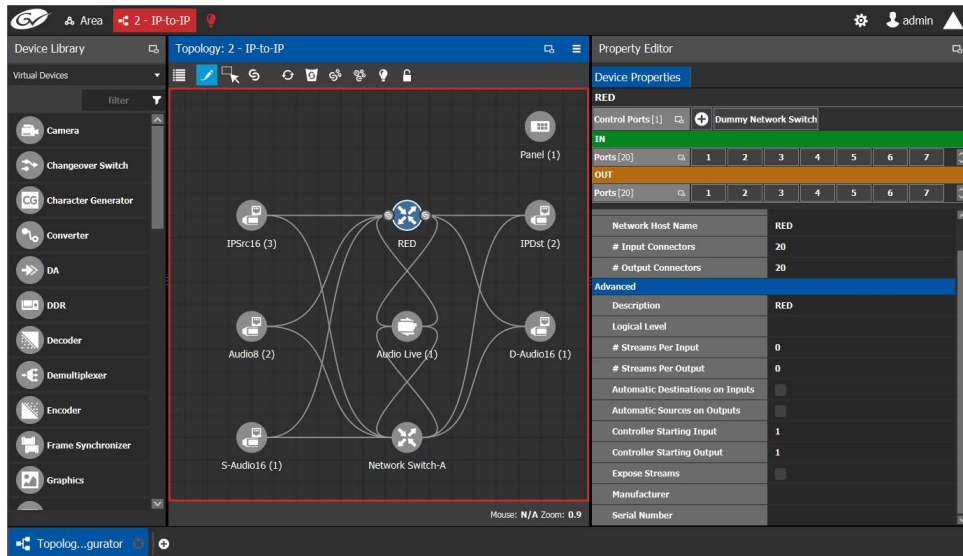

- 3 Click the unlocked Lock button at the top of the Topology Configurator.
No confirmation message appears.

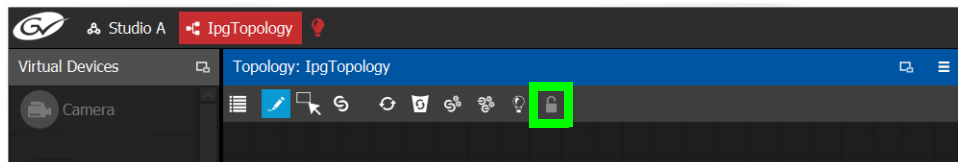

The **Lock** icon switches to the locked state.
No one can edit the topology.

Logical Device Table Tasks

Use the Logical Device Table task to view and configure the streams for the logical levels. Audio shuffling and breakaway can also be configured to create multiple streams with different audio channels (for example, for multi-language support).

The Logical Device Table task is also where you create virtual crosspoints (XPTs) and to configure logical destination devices that are related to these virtual XPTs. See [Configuring Virtual Crosspoints \(XPTs\)](#), on page 88.

Megasource is a logical source device that is defined with multiple streams, under multiple logical levels, that can be routed to a logical destination with at least one matching logical level. This allows the definition of a source device with multiple locations in the topology, where the destination devices' logical levels will determine which streams to route. For example, you may connect Bars to two different routers, the destination logical level will determine which of these two source streams are to be used. This is usually the source stream that is local to the destination. Megasource also allows for UHD quad-link sources to share a single stream of 16 channel audio and ancillary data with the 4 video streams. See [Using Megasource](#), on page 85 for more information.

Accessing the Logical Device Table task

To access the Logical Device Table Task

- 1 Open GV Orbit Control Stage. See [Navigating Back to Stage](#), on page 10.
- 2 Select an area. See [Selecting an Area](#), on page 23.
- 3 Select a topology. See [Selecting a Graph](#), on page 25.
- 4 Select **Configuration > Logical Device Table**.

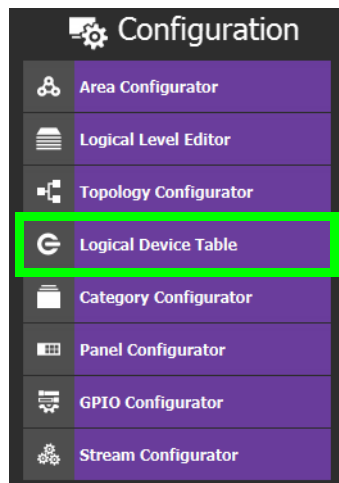

The Logical Device Table task appears.

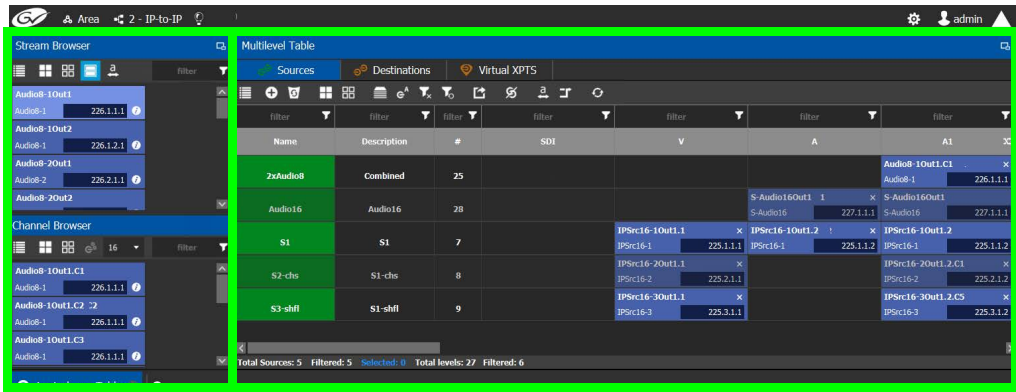

The default streams for your topology, are displayed in the left hand column under **Stream Browser**.

The following tabs are found in the right hand column under **Multilevel Table**.

Tab	Description
Sources	Show the currently configured sources. Sources are the available outputs for all the devices on your topology. See Adding a Source or Destination to the Logical Level Table , on page 79.
Destinations	Show the currently configured destinations. Destinations are the available inputs for all the devices on your topology. See Adding and Configuring a Destination , on page 85.
Virtual XPTS	Show the currently configured virtual crosspoints. See Configuring Virtual Crosspoints (XPTs) , on page 88.

- 5 Select the **Sources** tab to view the streams from the sources.
The Logical Level associated with the source are displayed. For information on the logical levels, see [Logical Level Editor Tasks](#), on page 30.
- 6 Scroll down in the **Sources** view to see all the levels for the selected source.

Stream Browser / Channel Browser

The Stream Browser shows all currently available steams. When a stream has two or more channels, the Channel Browser gives you access to the individual audio channels in a stream thereby allowing you to implement audio breakaway and audio shuffle for independent audio routing. See [Configuring Streams for New Sources / Destinations](#), on page 80.

To make use of this feature, streams will need to pass through a device that supports audio breakaway/shuffling, such as a hybrid router, GV Node, or Audio Live. See [Configuring a GV Node Device](#), on page 163 and [Configuring a Device that Supports Audio Breakaway/Shuffling such as Audio Live](#), on page 252.



The screenshot shows two windows: 'Stream Browser' and 'Channel Browser'. The Stream Browser window has a menu bar with icons for 'Select All', 'Clear All', 'Channel Browser', 'Show Long Names', 'Automated Sources', 'Automated Destinations', and 'Channels per Device'. The Channel Browser window shows a list of audio channels. Annotations with arrows point to specific elements:

- The selected stream (Audio8-1Out1)
- Shows detailed information about this stream (IP address 226.1.1.1)
- The Channel Browser shows the available audio channels for the selected stream (Audio8-1Out1.C1, C2, C3)
- Each audio channel can be dragged onto a different level in the Multilevel table to shuffle the source's audio

Note: if more than one stream is selected in the Stream Browser, then the Channel Browser shows all channels derived from the selected streams



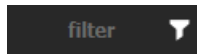









The Stream Browser and Channel Browser menu have the following menu options.



Icon	Description
Select All	Selects all items in the Stream Browser.
Clear All	Deselects all items in the Stream Browser.
Channel Browser	Shows the Channel Browser (found in the Stream Browser only).
Show Long Names	Toggles between the display of the long name or short name of the stream and device names.
Automated Sources Automated Destinations	Creates all the audio levels in the Multilevel Table for the selected streams. See also Configuring an IQAMD40 Device , on page 265 for an example of how to use this feature.
16 Channels per Device	Set how many channels are assigned per logical device when you have enabled the Automated Sources or Automated Destinations options. For example, if you select 64 streams in the channel browser, and you set Channels per Device to 16, and then you click the Automatic Sources option, it will automatically create 4 logical sources for you. The first 16 streams are assigned to A1-16 of the first source, the next 16 are assigned to A1-A16 of the second source, and so on. Likewise, if you select 64 streams in the channel browser, and you set Channels per Device to 8, and then you click the Automated Sources option, it will automatically create 8 logical sources for you. The first 8 streams assigned to A1-A8 of the first source, the next 8 assigned to A1-A8 of the second source, and so on. Similarly, if you select 64 streams, and set Channels per Device to 2, it will create 32 sources.

Icon	Description
 Filter	Filters the list. Note that the filter operates on the currently shown list items according to the Show Long Names setting. See Filtering Lists, Table Columns, Sources, and Destinations , on page 97.
 Information	Shows detailed information about the stream / channel.

Multilevel Table Menu

The Multilevel Table menu has the following menu options.

Icon	Description
 New	Creates a new Source / Destination / Virtual XPTS in the Logical Device Table. See Adding a Source or Destination to the Logical Level Table , on page 79, Adding and Configuring a Destination , on page 85, and Configuring Virtual Crosspoints (XPTs) , on page 88.
 Delete	Removes the currently-selected Source / Destination / Virtual XPTS in the Logical Device Table. See Deleting a Source, Destination, or Virtual XPTS , on page 87.
 Select All	Selects all rows in the Multilevel table.
 Clear All	Deselects all rows in the Multilevel table.
 Levels	Shows the Logical Level Selector. This allows you to set the logical levels that are to be shown in the Multilevel Table. See Setting the Logical Levels to be Displayed in the Multilevel Table , on page 78.
 Hide automatic sources	Shows or hides automatic sources / destinations in the Logical Device Table.
 Hide automatic destinations	
 Virtual Destinations	Shows the available destinations available from previously-configured virtual XPTS.
 Reset all filters	The columns of the Logical Device Table have filters. These buttons clear all filters and restores the previous filters. See Filtering Lists, Table Columns, Sources, and Destinations , on page 97.
 Reload all filters	
 Export	Exports the Logical Device Table to a CSV file. See Exporting a Logical Device Table , on page 88 or Selecting all Devices in the Logical Device Table for Export , on page 88.
 Restore default label	When a source or destination has been renamed, this resets the name to its original label.
 Show Long Names	Toggles between the display of the long name or short name of the stream and device names.

Icon	Description
 Show Redundant Streams	For each stream in the Multilevel Table: <ul style="list-style-type: none">• When a source or destination has redundant IP streams (as may be the case with an SMPTE ST 2022-7 network for example), for each stream in the Multilevel Table, this toggles between the display of the IP address for the primary stream and the display of the IP address for the secondary stream.• When this option is selected, and the stream has a secondary IP address to be shown, the stream's secondary IP address is shown with a blue background to identify that the secondary stream's IP address is currently being shown. Streams that have no redundancy (no secondary IP address) are unaffected by this option.
 Refresh	Reloads the Logical Device Table's contents.

About the Multilevel Table and GVOP Devices

When the following conditions are met, the device's configuration is read from the GVOP device in real time and GV Orbit Client automatically creates / updates sources and destinations for these GVOP devices in the Logical Device Table's Multilevel Table:

- The device uses GVOP (see [GVOP Devices](#), on page 46), and the **Automatic Sources and Destinations** parameter is enabled in the device's properties (this is the default setting; see [Device Properties Definitions](#), on page 64).
- The device is online.

For example, if the Flow Type for a video flow is assigned to SMPTE2022 in a GVOP device, then in the Multilevel Table, this flow appears as an SDI flow for this device and the SMPTE ST 2110-20, 2110-30, and 2110-40 flows are not used. Likewise, if an SMPTE ST 2110-30 audio flow is set to None, then in the Multilevel Table, this flow is no longer applied to the audio level for the given source or destination.

About Automatic Sources or Destinations

Certain sources and destinations are created automatically by GV Orbit Control, such as edge devices: cameras, monitors, and so on. Automatic sources or destinations are created when the following properties (as applicable) have been set in the device's property editor:

- Automatic Sources and Destinations
- Automatic Destination
- Automatic Destinations on Inputs
- Automatic Destinations on Outputs
- Automatic Source
- Automatic Sources on Outputs
- Automatic Sources on Inputs

See also [Device Properties Definitions](#), on page 64.





The **A** icon is shown next to the name for the row in the Multilevel Table to indicate that the source or destination was automatically created by GV Orbit Control.



Note: You cannot delete a default source from the Logical Level Table. However, you can modify the levels associated with the source. Also, you can modify or delete the sources that you create.

Automatically created sources' and destinations' name can be re-named by double-clicking the name field. A yellow bar indicates that the name of the source or destination is no longer the automatically-generated name. Click  **Restore default label** to revert back to the automatically-generated name.

Such automatically generated sources and destinations have icons to represent the source or destination type when shown, for example, in the Panel Configurator, Category Configurator, or elsewhere. A key to a few source and destination icons is shown below. These icons are derived from the icon used to represent the device in the Device Library and on the Topology Configurator. See [Adding Devices to a Topology](#), on page 44.

Icon	Description
	Camera source
	Logical device source
	Encoder source
	Monitor destination
	Default destination for a panel. See Creating a Single-Destination Work Flow Panel , on page 127.

If you try to delete an automatic source or destination from the Logical Device Table, the following message is displayed at the bottom of the task.

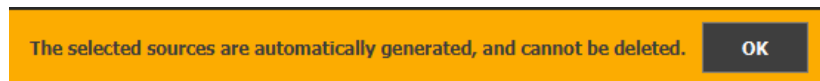

To remove an automatic source or destination, you must deselect the following properties (as applicable) in the device's Property Editor:

- Automatic Sources and Destinations
- Automatic Destination
- Automatic Destinations on Inputs
- Automatic Destinations on Outputs
- Automatic Source
- Automatic Sources on Outputs
- Automatic Sources on Inputs

Setting the Logical Levels to be Displayed in the Multilevel Table

You can show or hide the Logical Level shown in the Multilevel Table. For example, once you have created custom levels in the Logical Table Editor, you might want to show those levels while hiding others that are not of interest for the moment. Showing or hiding Logical Levels in the Multilevel Table is used to facilitate bulk assignment of sources and destinations in the Multilevel Table. See [Bulk Assigning Logical Levels in the Multilevel Table](#), on page 84.

To modify the logical levels associated with a source / destination

- 1 Select a Source / destination in the Logical Device Table. See [Accessing the Logical Device Table task](#), on page 72.
- 2 Click the Logical Levels icon  at the top of the table.
 A secondary window opens displaying the levels for the selected source / destination.

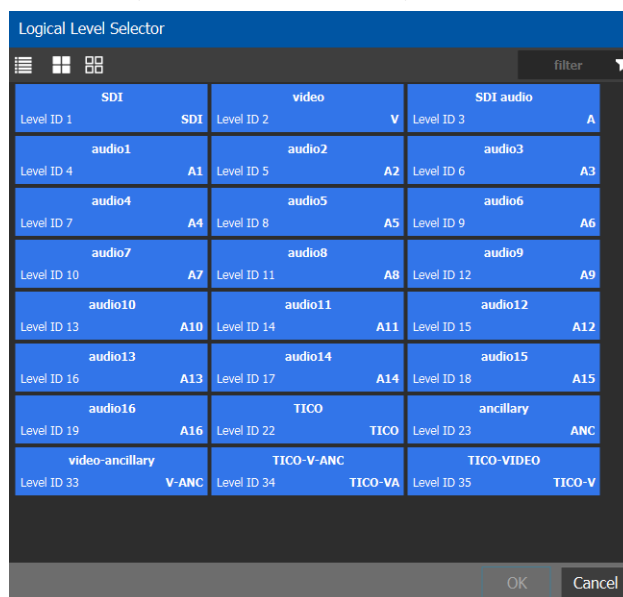

- 3 Select one or more levels you want to use for the selected source / destination.
- 4 Click **OK**.

The columns in the Multilevel Table adjust to show the ones you have selected.

Adding a Source or Destination to the Logical Level Table

By default, the logical device table displays the sources and destinations in the selected topology in the **Sources** and **Destinations** tabs. You can add a logical device to the table that is not on the topology. You would then have the option of switching to the new logical device in place of the existing device.

To add a source or destination to the logical level table

- 1 Open the logical level table for the required topology.

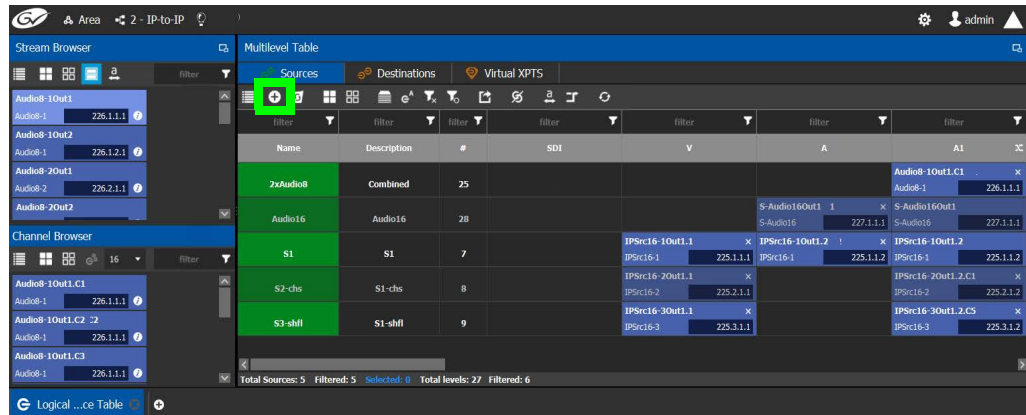

- 2 Select the **Sources** or **Destinations** tab.
- 3 Click **New**  at the top of the **Multilevel Table**.

A secondary window appears.

Base Name:	CAM100
Start Index:	1
Count (Max 200):	5
<input type="button" value="OK"/> <input type="button" value="Cancel"/>	

- 4 Enter the required information in the **Base Name**, **Start Index**, and **Count** fields.
- 5 Click **OK**.

New sources / destinations are created. The **Base Name** is displayed under the **Name** and **Description** fields. The number of new sources / destinations created corresponds to the number you enter in the **Count** field.

Name	Description	#	SDI	V	A
Cam1001	Cam1001	302			
Cam1002	Cam1002	303			
Cam1003	Cam1003	304			
Cam1004	Cam1004	305			
Cam1005	Cam1005	306			
SZX-1	SZX 1 Out 1	294	SZX-1	SZX-1	SZX-1
SZX-2	SZX 2 Out 1	297	SZX-2	SZX-2	SZX-2
SZX-3	SZX 3 Out 1	295	SZX-3	SZX-3	SZX-3
SZX-4	SZX 4 Out 1	296	SZX-4	SZX-4	SZX-4
S9-1	S9 1 Out 1	298	S9-1	S9-1	S9-1
			S9-2	S9-2	S9-2

In the example, five new sources are created. The name for each device begins with the base name CAM100. A number is appended to the base name. This begins with the starting index and increases by one for every number in the count.

Configuring Streams for New Sources / Destinations

After creating new sources / destinations, the next step is to configure the streams for them. Different streams can be assigned to different levels, so that a source / destinations is composed of streams from different devices (to do an implicit breakaway).

For example, the column you drop a stream on in the Multilevel table selects the part of the stream to use to create the logical device. This is shown below for a stream from the Stream Browser.

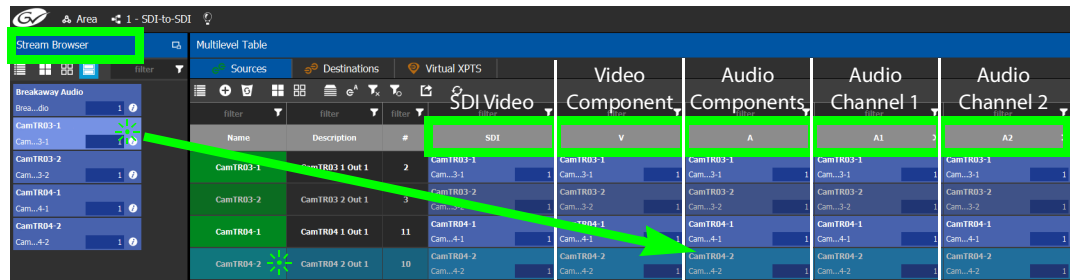

Select the row before dropping a source / destination onto it

Stream Drop onto Multilevel Table Column	Description
SDI	This fills all levels (video, 16 audio channels (A1 to A16), ANC, and V-ANC) with the equivalent levels from the SDI video stream.
V	This takes the video level only from the SDI stream.
A	This takes the audio levels only from the SDI or audio stream for all 16 audio channels (A1 to A16).
A1 to A16	This takes the first audio channel from the SDI or audio stream.
ANC	This takes the ANC level only from the SDI stream.
V-ANC	This takes the V-ANC level only from the SDI stream.

For instance, you could create a source with Video from a GV Node and the audio from an IPG-3901, or IPG-4901. You do this by assigning the GV Node stream under the **SDI** column, and the IPG-3901, or IPG-4901 stream under the **Audio (A)** column. If audio breakaway/shuffling is required to complete the path, GV Orbit Control will automatically choose a route through Audio Live for example.

LIMITATIONS

- Any shuffling done internally in a card through iControl or RollCall is not taken into account by GV Orbit Control and is not controlled by GV Orbit Control. Such shuffling is local to the card and this can result in unexpected shuffling should the card's processing path be dynamically assigned by GV Orbit Control to another use or destination, where such internal shuffling would be detrimental.
- You cannot shuffle audio to the same destination more than once. For example, the same Destination channel is added to a destination from the Channel Browser three times. This will not work and must be avoided, as multiple sources cannot be routed to the same destination. A destination can only resolve to a single source.

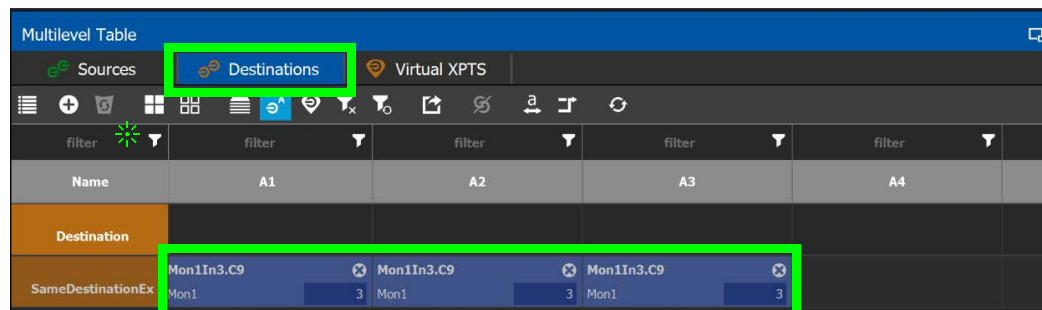

To configure streams for the new sources

- 1 Open the Logical Device Table for the required topology.
 In the left hand column under **Stream Browser**, the default streams for your topology are displayed.
- 2 Add sources to the Logical Level Table. See [Adding a Source or Destination to the Logical Level Table](#), on page 79.
- 3 Select a source's row to which you want to add a stream.

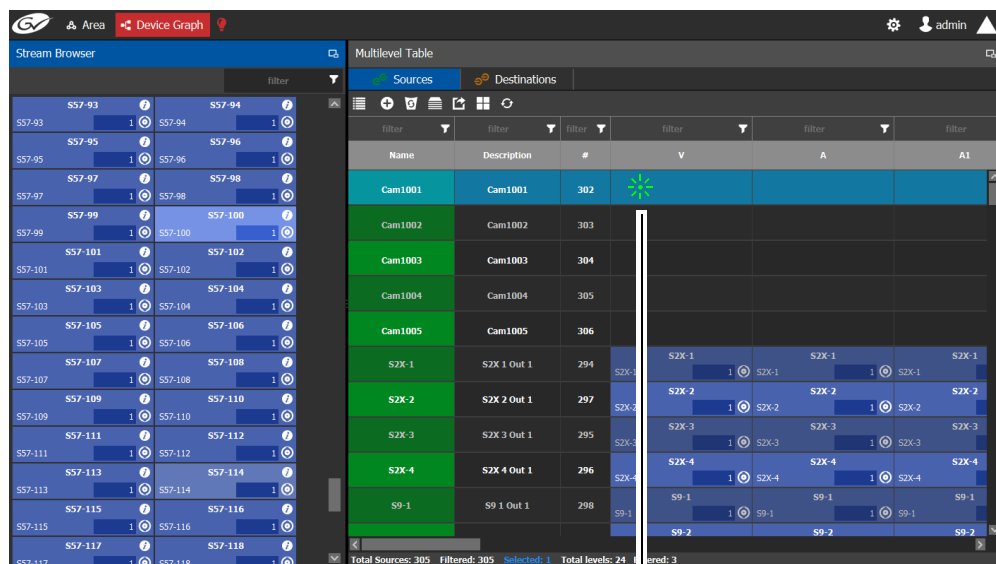

Select the row before dropping a source / destination onto it

4 Drag a stream onto the source.

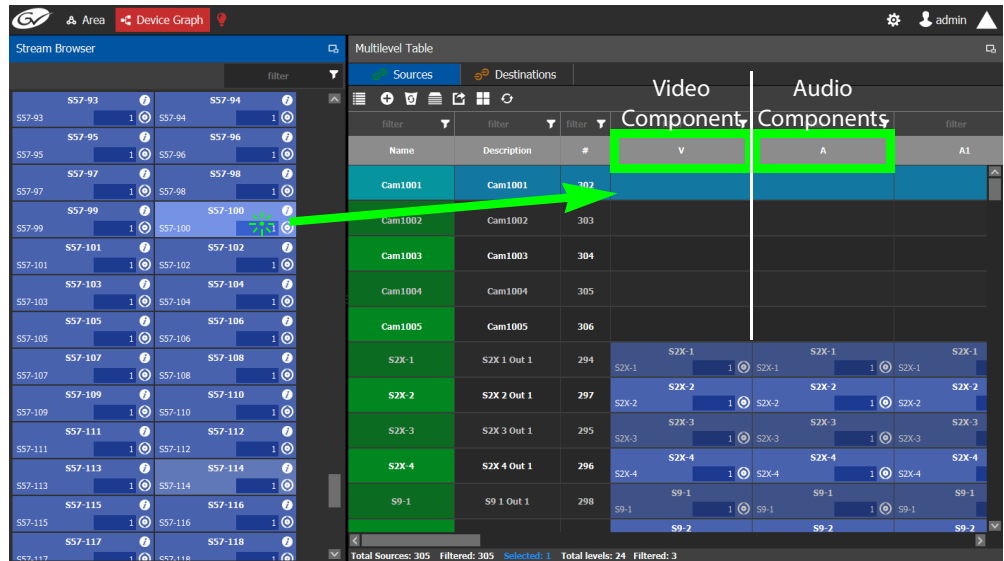

In the above image, a stream is added to a source for its video component. Optionally drag the same stream or another stream from the **Stream Browser** to a source to add its audio components.

- To create an audio or video breakaway with this new source or destination, once the stream has been assigned to the **SDI** column, drag another stream from the Stream Browser onto the Video (V), Audio (A, A1 to A16), or **ANC** column to use that specific flow component from that second stream.

To indicate that the source / destination is composed of streams from more than one device (this includes a video or audio breakaway), the following  symbol is shown with the name of the new source / destination.

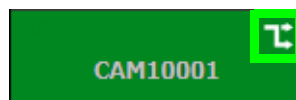

Configuring Streams for Audio Live Audio Channels

When using Audio Live in your topology or a similar device (see [Configuring a Device that Supports Audio Breakaway/Shuffling such as Audio Live](#), on page 252), you can:

- From the Stream Browser, drop the main audio stream (never the redundant audio stream) onto the audio (A) column.
- From the Channel Browser, drop one or more audio channels from the stream onto the A1 to A16 column(s). To open the Channel Browser, click . See also [Stream Browser / Channel Browser](#), on page 73.

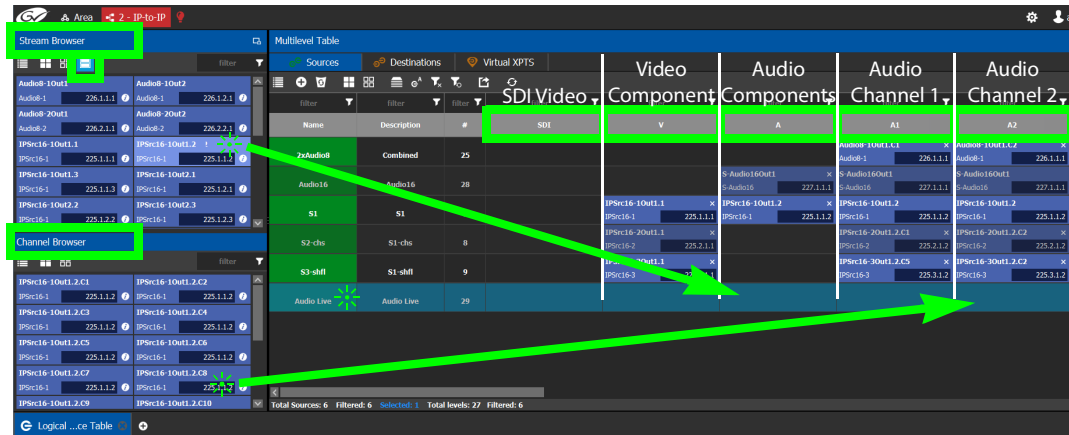

Bulk Assigning Logical Levels in the Multilevel Table

The Stream Browser and Channel Browser have filters that allow you to refine the stream selection shown. See [Filtering Lists, Table Columns, Sources, and Destinations](#), on page 97. It is often possible that by using filtering, streams can be grouped together so that they can be dropped in bulk onto the Multilevel Table, on a row or a column.

- To bulk drop streams on to a row, select one row first and then select two or more streams to drop onto the row.

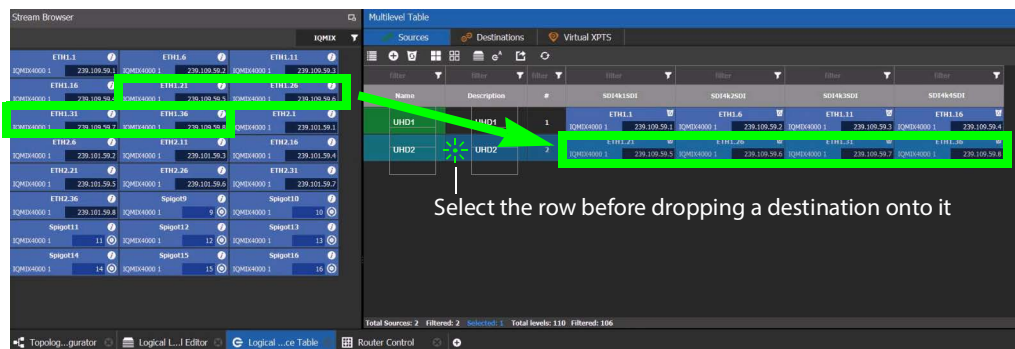

- To bulk drop streams on to a column, select two or more rows first and then select two or more streams to drop onto the column.

Adding and Configuring a Destination

The procedures for adding and configuring destinations are the same as for adding and configuring sources. For details, see [Setting the Logical Levels to be Displayed in the Multilevel Table](#), on page 78, [Adding a Source or Destination to the Logical Level Table](#), on page 79, [Configuring Streams for New Sources / Destinations](#), on page 80, and [Bulk Assigning Logical Levels in the Multilevel Table](#), on page 84.

Destinations have the **IP Clean Switch** option which enables the routing of an IP source to a local GV Node destination for a vertically accurate switch.

Using Megasource

Megasource changes GV Orbit Control's pathfinding rules to match exact logical levels before applying best match logic. This allows you to create logical sources where the same or different streams can be added to the logical level columns that share the different custom logical levels. Megasource only applies to sources with multiple stream/level pairings and the filtering happens when a normal destination is used in a route.

When doing a take, the GV Orbit Control's pathfinding algorithm will attempt to find an exact level match between the logical source and the logical destination. Failing to find an exact match, it attempts to find a compatible level match as it currently does. If there is more than one possible compatible match (ambiguous take), it will fail the take because we don't know which stream should be used on the logical destination.

Note that a UHD 4K take is a subset of this feature where there are four SDI levels per logical source and logical destination (one SDI level for each quad-link or two-sample interleave division substream component). See [Creating the Logical Levels for a UHD 4K Routing Setup](#), on page 34 for more information.

For example, you have three SDI signals from the same source. One signal is full resolution 1080p video, the second signal is 720p video, and the third is 480p video. One destination is for the full resolution 1080p video, the second destination is for the 720p video, the second destination is for the 480p video, where the destination devices' logical levels will determine which streams to route.

The following is an example of how to do this.

Using Megasource

- 1 Create the following Topology to use for this example. See [Adding Devices to a Topology](#), on page 44.

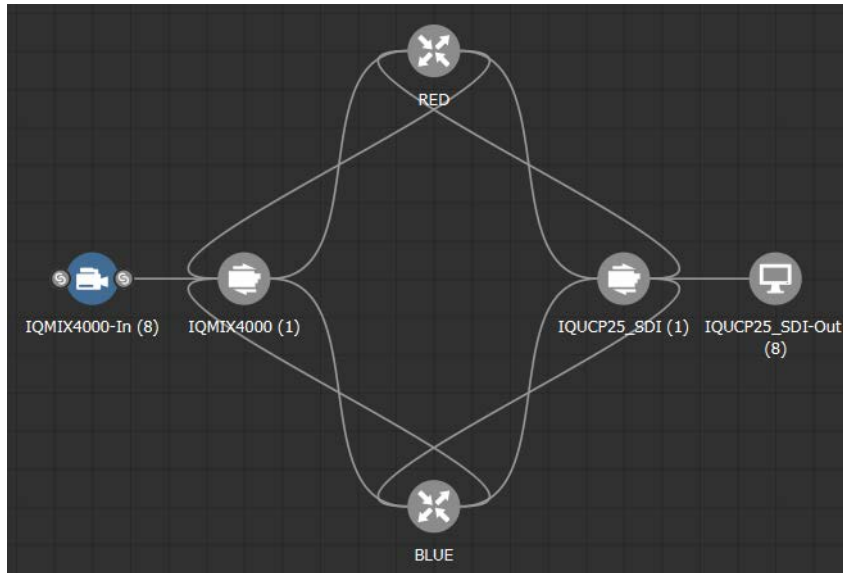

- 2 Create three copies of the **SDI** Logical Level called **SDI-A**, **SDI-B**, and **SDI-C** in the **Logical Level Editor**. See [Duplicating a Logical Level](#), on page 33.
- 3 Click in the **Multilevel Table**, **Sources** tab, of the **Logical Device Table** to hide the automatically-generated sources. See [Multilevel Table Menu](#), on page 75.
- 4 Click in the **Multilevel Table**, **Sources** tab, of the **Logical Device Table** to create a new source (shown in this example as *Megasource*). See [Adding a Source or Destination to the Logical Level Table](#), on page 79.
- 5 In the Logical Device Table, select a source's row to which you want to add the streams. See [To configure streams for the new sources](#), on page 82.
- 6 From the Stream Browser of the **Logical Device Table**, drag the three source streams onto the Multilevel Table. The first stream represents 1080p video, the second stream represents is 720p video, and the third stream represents 480p video.

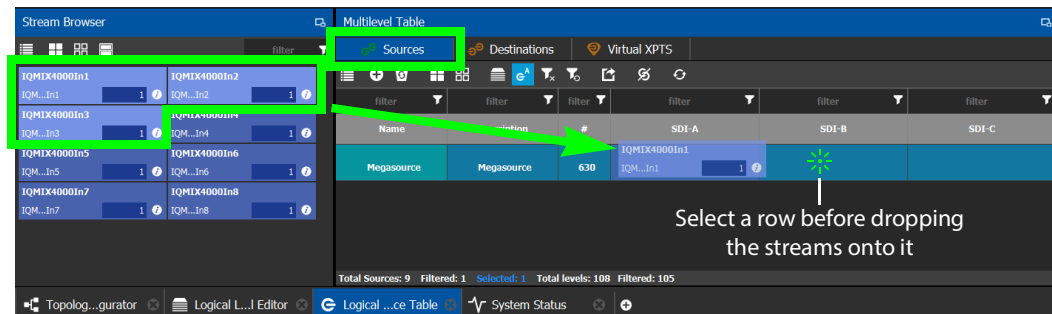

- 7 Click in the **Multilevel Table**, **Destinations** tab, of the **Logical Device Table** to hide the automatically-generated destinations. See [Multilevel Table Menu](#), on page 75.

- 8 Click  in the **Multilevel Table, Destinations** tab, of the **Logical Device Table** to create new destinations, one for each level (1080p, 720p, and 480p video). See [Adding a Source or Destination to the Logical Level Table](#), on page 79.
- 9 In the Logical Device Table, select the first source's row to which you want to add the streams.
- 10 From the Stream Browser of the **Logical Device Table**, drag the first destination stream onto the Multilevel Table.
- 11 In the Logical Device Table, select the second source's row to which you want to add the streams.
- 12 From the Stream Browser of the **Logical Device Table**, drag the second destination stream onto the Multilevel Table.
- 13 In the Logical Device Table, select the third source's row to which you want to add the streams.
- 14 From the Stream Browser of the **Logical Device Table**, drag the third destination stream onto the Multilevel Table.

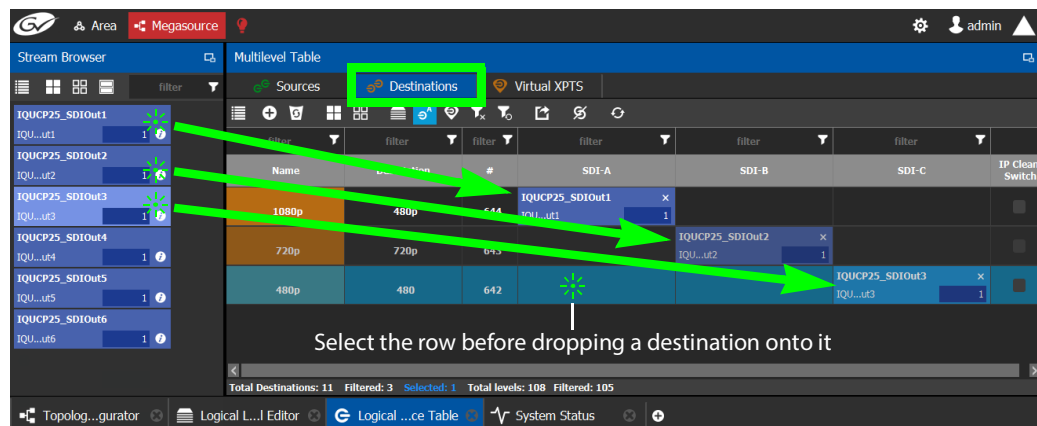

- 15 Test the configuration by making takes between a logical source and destination that use the *Megasource* source. See [Performing a Take in Router Control](#), on page 290. See in Pathfinder that the correct source resolution is received by each destination. See [Viewing Information about the Destinations](#), on page 274.

Deleting a Source, Destination, or Virtual XPTS

You can delete any source, destination, or virtual XPTS that you have created.

To delete a source, destination, or virtual XPTS

- 1 Open the Logical Device Table task for the required topology.
- 2 Select the Sources tab, the Destination tab, or virtual XPTS tab according to what you are deleting.
- 3 Select the sources, destinations, or virtual XPTS in the table.

Note: You can delete one or more sources or destinations at the same time.

- 4 Click the **Delete** icon .

Exporting a Logical Device Table

You can export the data in your logical device table in a csv file.



To export a logical device table

- 1 Open the Logical Device Table task for the required topology.
- 2 Select the rows you want to export.
- 3 Click the **Export** icon .
- 4 Navigate to the folder where you want to save the file.
- 5 Click **Save**.

Selecting all Devices in the Logical Device Table for Export

You can select all devices in the logical device table, for example, to export the Device Table's configuration data to a csv file.

To select all the devices and save their configuration data

- 1 Open the Logical Device Table task for the required topology.
- 2 Click the **Select All** icon .
- 3 Click the **Export** icon .
- 4 Navigate to the folder where you want to save the file.
- 5 Click **Save**.

Configuring Virtual Crosspoints (XPTs)

Without virtual XPTs, only one route can be made for each task. Virtual XPTs are used when multiple outputs are required to be switched to the same source *in a single take*.

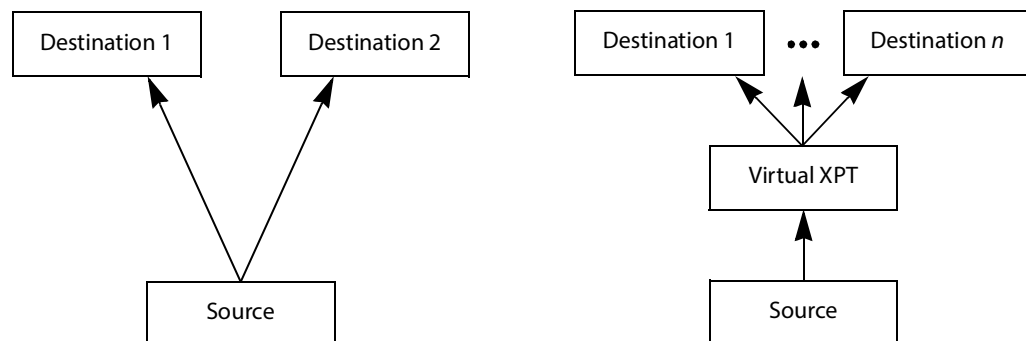

Virtual XPTs can be used to:

- Show user-friendly device names on the operators' control panels. For example, the name of the virtual XPT is shown on control panels when used.
- Hide implementation details from the operator(s). For example, in a transparent fashion, an output signal is also sent to a monitor.

Virtual XPTs are used for the following two primary applications:

- Monitoring: to follow the source routed to a given destination and to route that same source to other destinations as needed.
- Utility DA (distribution and amplifier): to allow for a configurable virtual destination/source that can be routed to other real destinations.

The following virtual XPT functional behaviors are by design:

- A take with a virtual XPT will fail if the path to the source does not exist and as a consequence the virtual source will fail. The status (Tally) will not reflect this.
- A take with a virtual XPT's destination will be ignored if the take fails.
- A logical destination can only be added to one virtual XPT destination at a time. Once a real destination has been added to a virtual XPT, it is no longer available to be used with other virtual destinations. A pop-up message is shown if you try to add a logical destination that has already been added to another virtual XPT. Click **OK** to remove the logical destination from the previous virtual XPT and add to it the new virtual XPT.
- You can only route virtual sources to unrelated virtual destinations that are not associated with the same virtual XPT. This allows you to increase the number of logical destination devices that can be switched with a single route. Routing a logical source device to the virtual destination of another virtual XPT will route said source to all logical destination devices that the virtual source is routed to. Routing that virtual source to another virtual destination, will mean routing the original logical source device to all destination devices that the corresponding virtual source was routed to, as well.

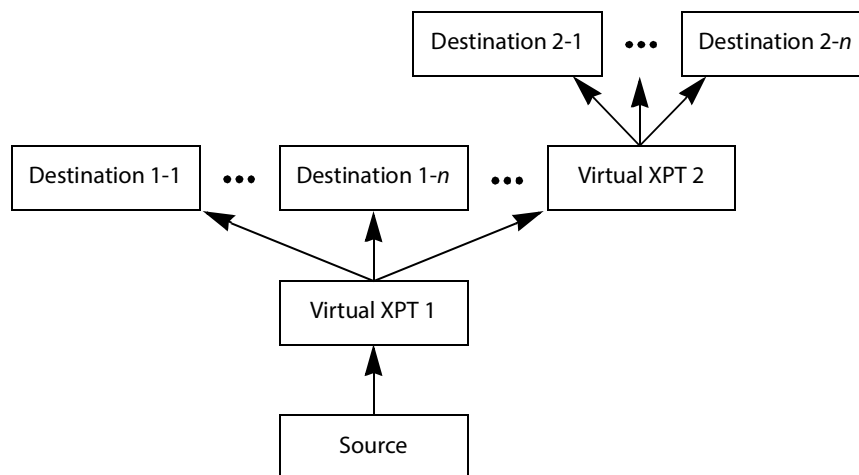

Routing a logical source device to the virtual destination of another virtual XPT

- A virtual XPT can have up to 100 real logical destinations.
- The status of a virtual XPT is shown in the Path Manager. See [Accessing the Path Manager](#), on page 271.
- Adding a logical destination device to a virtual XPT changes the status of the destination to the virtual source - with the logical source device content being routed to the logical destination device(s). Removing the logical destination device from a virtual XPT, will change the status of that destination to the logical source device.

Virtual XPT Use Scenario 1

In this scenario, the physical level is set up so that any source routed to destination Z will be taken to the following destinations: R, S, and T.

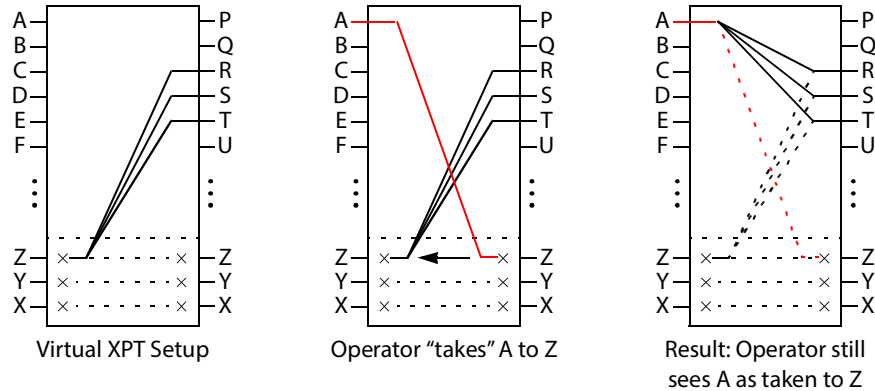

If the operator takes A to Z, the software “discovers” that source Z is virtually routed to R, S, and T. Therefore, it routes A to R, S, and T as real routes.

Here, a source was taken to multiple destinations with a single take, and that fact was concealed from the operator. The operator’s control panel reports that A was taken to Z. The Path Manager can be used to know the actual path that was internally used by the router; see the [Path Manager Tasks](#), on page 270.

Other inputs can be taken to Z with a similar result: that source will be taken to destinations R, S, and T.

Virtual XPT Use Scenario 2

In this scenario, the virtual XPT setup is the same as for scenario 2.

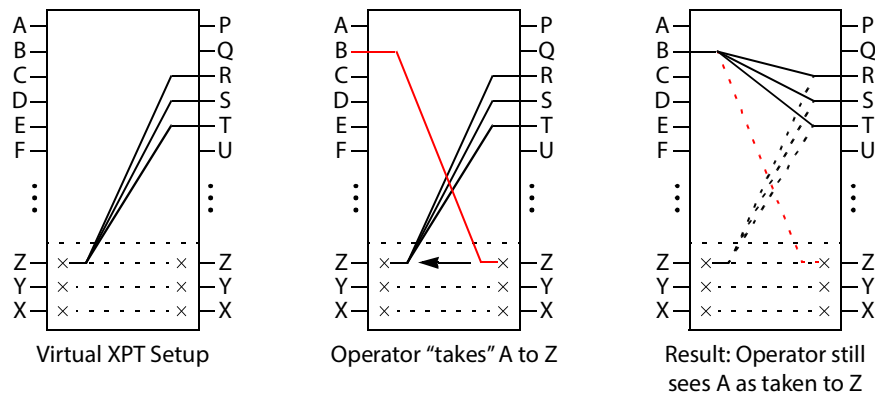

If the operator takes B to Z, the software “discovers” that source Z is virtually routed to R, S, and T. Therefore, it routes B to R, S, and T as real routes.

The operator’s control panel reports that A was taken to Z. The operator executed a single take.

This scenario illustrates that any time an operator takes a source to virtual XPT destination n , the router actually takes the source to the real destinations “connected” to virtual XPT source n .

To create Virtual XPTs

Virtual XPTs are created in the Logical Device Table task.

- 1 In the Topology Configurator, activate the topology. See [Activating a Topology](#), on page 66.
- 2 Open the Logical Device Table task. See [Accessing the Logical Device Table task](#), on page 72.
- 3 Select the **Virtual XPTs** tab.

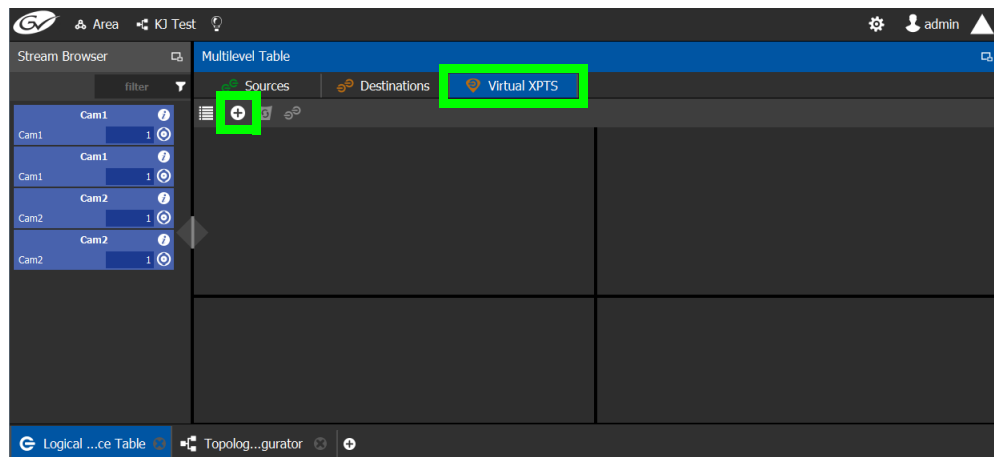

- 4 Click **New** 

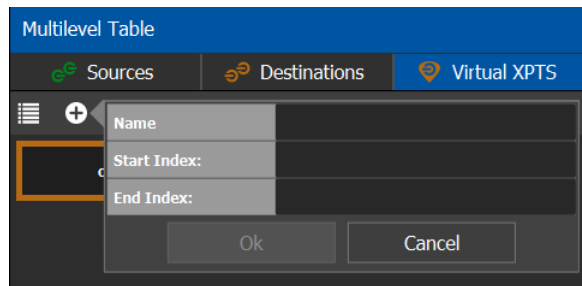

- 5 Enter a name for the new virtual XPT and click **OK**.

Optionally, a range of virtual XPTs can be created: The **Name** parameter is the prefix for the generated virtual XPTs. The **Start Index** is the index starting value, and the **End Index** is the last index value for the virtual XPT range.

The new virtual XPT is added to the **Multilevel Table** under the **Virtual XPTS** tab.



A new logical source and a new logical destination are created automatically in the system with the name of the virtual XPT.



Virtual source and destination filters are available for you to filter on virtual XPTs when configuring the panel, categories, and router control user interfaces. See [Filtering Lists, Table Columns, Sources, and Destinations](#), on page 97

- 6 Add the default destinations for the virtual XPT. Select the virtual XPT and then click Destinations .

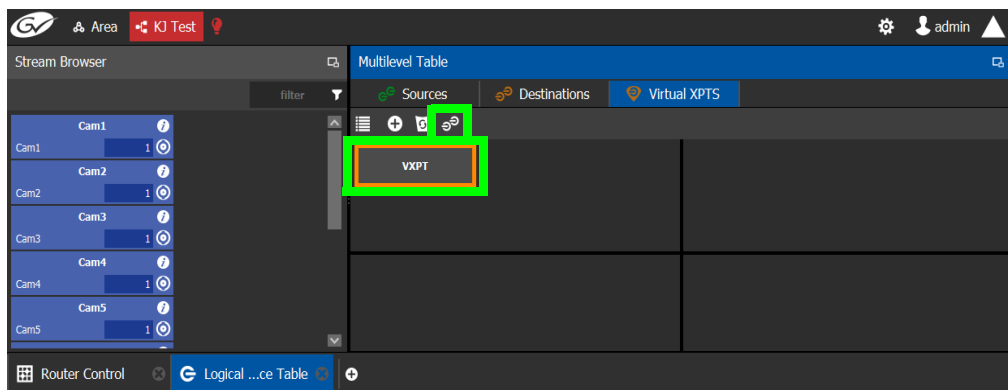

A list of all currently available destinations appears.

- 7 Select the default destinations the virtual XPT will use and click OK.

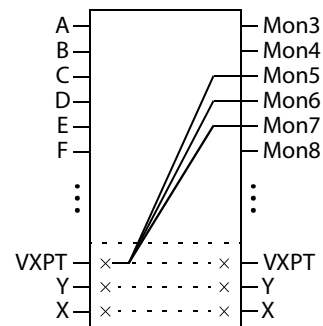
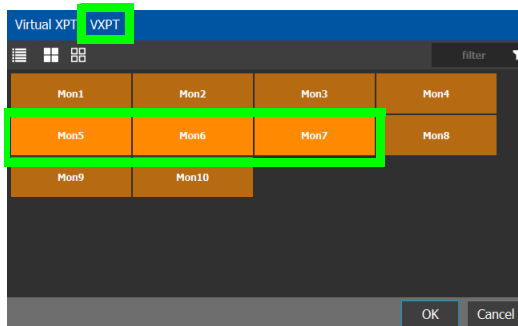

In this scenario, the physical level is set up so that any source routed to destination **VXPT** will be taken to the following destinations: **Mon5, Mon6, and Mon7**.

Once you have created one or more Virtual XPTs, you can start using them in Router Control.

To perform a take with a Virtual XPT

You must first create and activate the topology in the Topology Configurator. You perform takes with a Virtual XPT in Router Control. See also [Performing a Take in Router Control](#), on page 290.

- 1 In the Topology Configurator, activate the topology. See [Activating a Topology](#), on page 66.
- 2 Create a virtual XPT in the Logical Device Table task. See [To create Virtual XPTs](#), on page 91. As an example, in this procedure, the name of the virtual XPT is **VXPT**.
- 3 Open Router Control. See [Accessing the Router Control Task](#), on page 289.

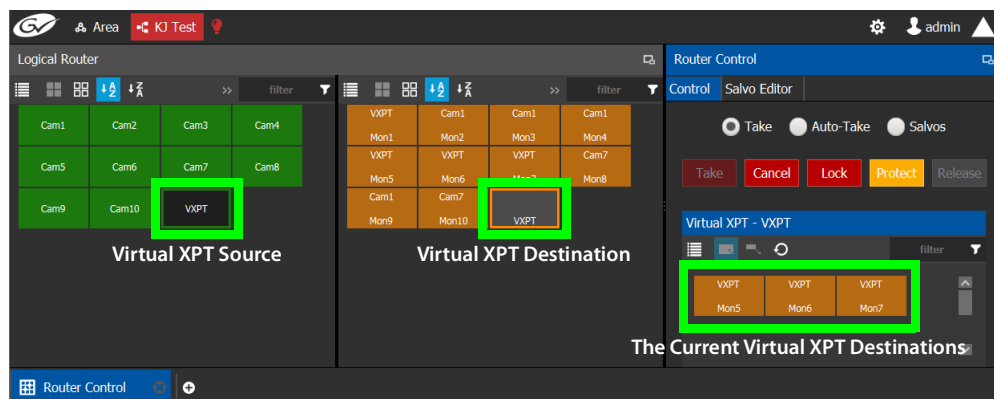

The default virtual XPT destinations that were configured in the Logical Device Table are shown by selecting the virtual XPT destination. See [To create Virtual XPTs](#), on page 91.

- 4 To route Cam1 to Mon5, Mon6, and Mon7 using the virtual XPT **VXPT**, perform a take **Cam1** to destination **VXPT**.

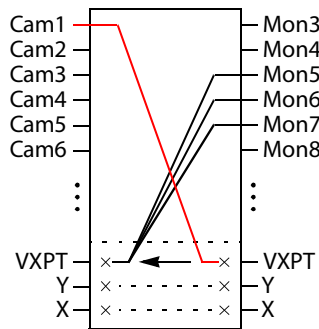

First click the destination virtual XPT **VXPT** and then click **Cam1** and finally click **Take**.

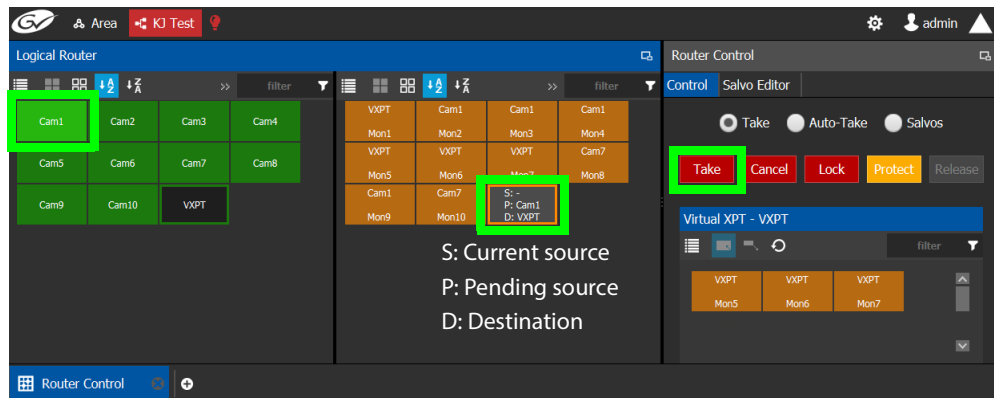

The destination virtual XPT **VXPT** button shows the current source.



The Path Manager can be used to know the actual path that was internally used by the router; see the [Path Manager Tasks](#), on page 270.

To dynamically add a Virtual XPT destination

Destinations can dynamically be added to a virtual XPT. In this example, **Mon8**, and **Mon9** are added to the virtual XPT **VXPT**'s destination.

- 1 In the Topology Configurator, activate the topology. See [Activating a Topology](#), on page 66.
- 2 First click the source virtual XPT and then click **Mon8** and finally click **Take**.
- 3 First click the source virtual XPT and then click **Mon9** and finally click **Take**.

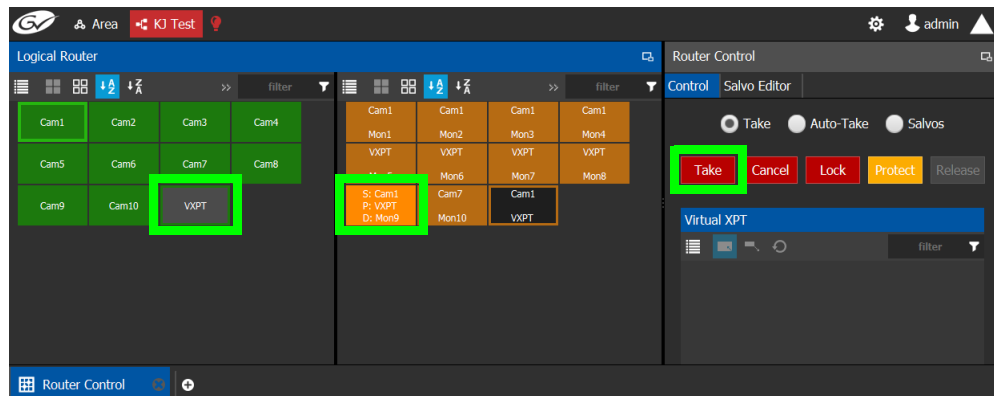

The current destinations for the selected virtual XPT are updated.

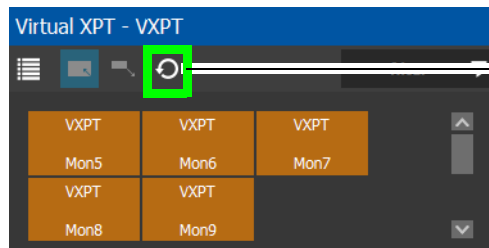

Click to revert to the default virtual XPT destinations configured in the Logical Device Table

See also [Performing a Take in Router Control](#), on page 290 for more information about how to use the controls available in this window. The Path Manager can be used to know the actual path that was internally used by the router; see the [Path Manager Tasks](#), on page 270.

To dynamically remove a Virtual XPT destination

Destinations can dynamically be removed from a virtual XPT. In this example, **Mon9** is removed from the virtual XPT **VXPT**'s destinations. This is done by assigning the destination to be removed to another source.

- 1 In the Topology Configurator, activate the topology. See [Activating a Topology](#), on page 66.
- 2 First click the destination **Mon9** then click **Cam9** and finally click **Take**.

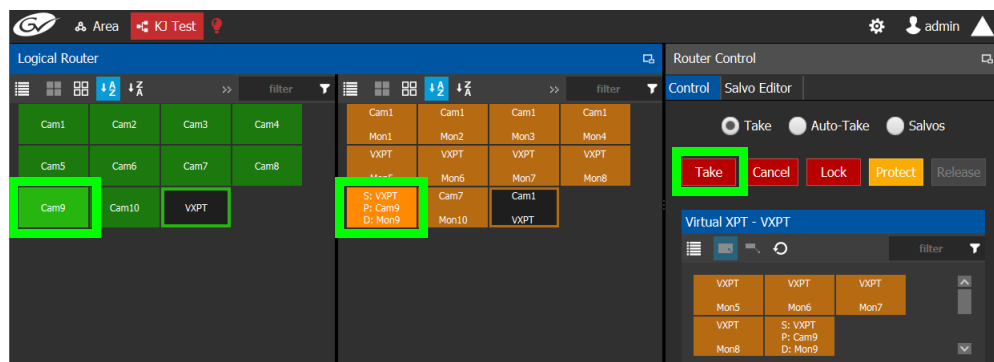

Minimize and Expand Virtual XPT Destinations

In the Router Control Task, when a virtual XPT is routed to another virtual XPT, the second virtual source is nested in the first virtual XPT. See [Routing a logical source device to the virtual destination of another virtual XPT](#), on page 89.

As shown below, when **Minimize Virtual XPT** is selected, the VXPT2 virtual XPT is shown minimized.

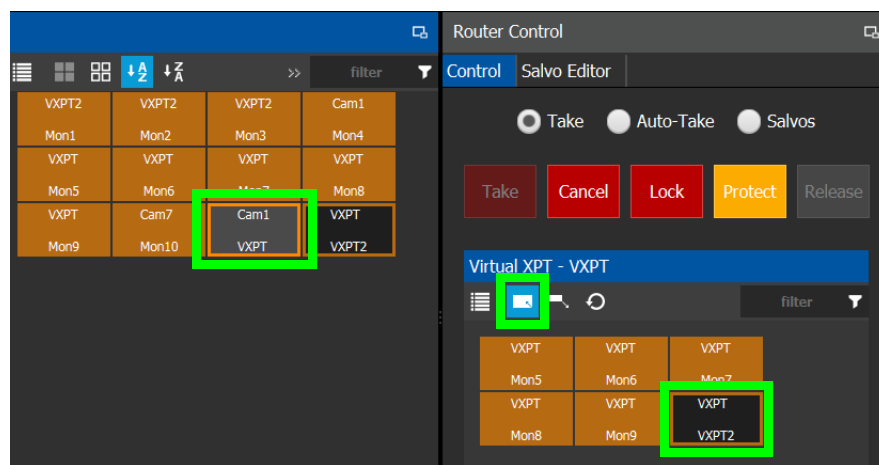

As shown below, when **Expand Virtual XPT**  is selected, all destinations are shown, including the nested destinations of all other virtual XPTs.

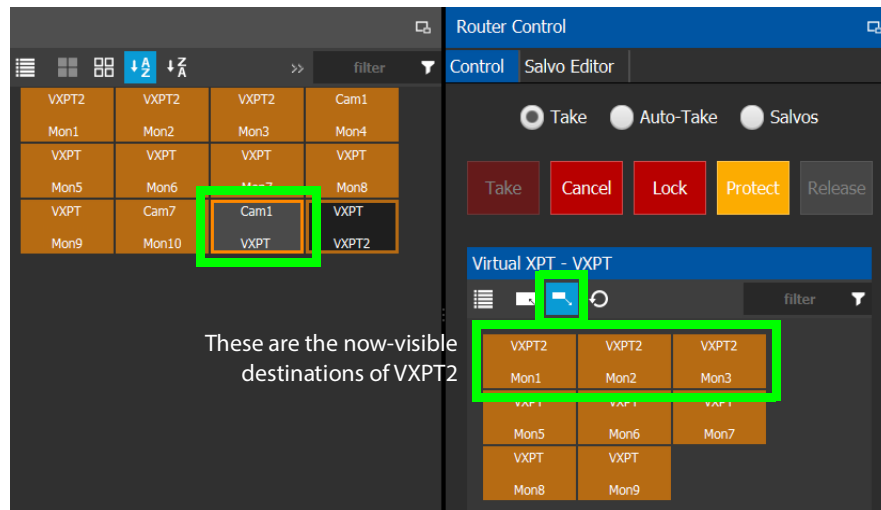

See also [Performing a Take in Router Control](#), on page 290 for more information about how to use the other controls available in this window.

Filtering Lists, Table Columns, Sources, and Destinations

Virtual source and destination filters are available for you to filter on virtual XPTs when configuring the panel and category configurator user interfaces. To show virtual XPT sources or destinations only, enable the **Show virtual** setting in the filters dialog only.

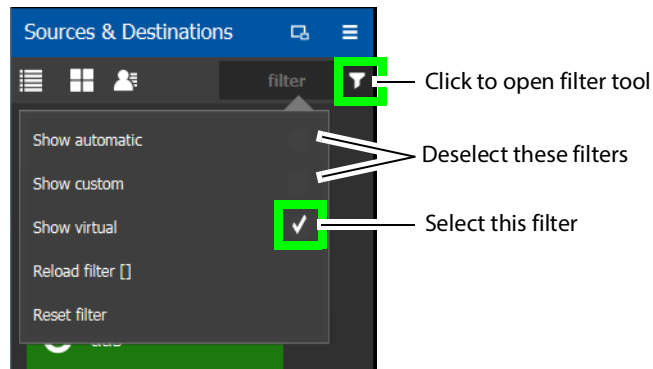

The functions available in a filter adapt to the screen in which the filter is found. For example, the Stream Browser has filters to allow you to filter streams that come from either input or output ports.

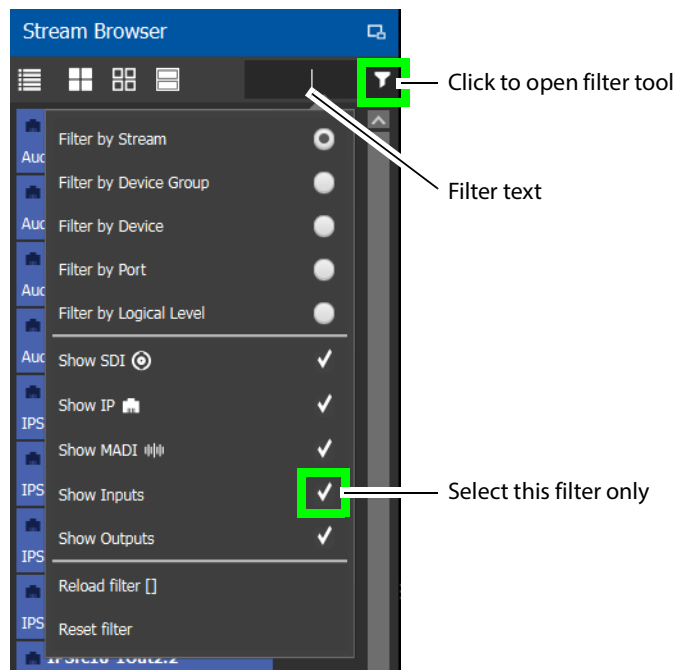

Filter Parameter	Description
Reload filter []	Reloads the previously-used filter.
Reset filter	Clears the text in the filter function.
Filter by Stream	Filter by the stream's name.
Filter by Device Group	Filter by the device group's name.
Filter by Device	Filter by the device's name.
Filter by Port	Filter by the port's name.

Filter Parameter	Description
Filter by Logical Level	Filter by the Logical Level's name.
Show SDI	Show results where the connection type is SDI.
Show IP	Show results where the connection type is IP.
Show MADI	Show results where the connection type is MADI.
Show Inputs	Show results where the connection direction is an input.
Show Outputs	Show results where the connection direction is an output.
Show automatic	Show automatically-created sources and destinations.
Show custom	Show user-created sources and destinations.
Show virtual	Show virtual XPTS.

Category Configurator Tasks

Use the Category Configurator to make it easier to manage the sources in your topologies. Creating groups of categories, based on type or use, is useful when you have multiple resources.

Categories are used to group sources and destinations together thereby allowing them to be accessed quickly on a panel, either by adding a category button or by using keyboard shortcuts. See also [Panel Configuration Example Using Categories with Custom Navigation](#), on page 132.

Accessing the Category Configurator

To access the Category Configurator Task

- 1 Open GV Orbit Control Stage. See [Navigating Back to Stage](#), on page 10.
- 2 Select an area. See [Selecting an Area](#), on page 23.
- 3 Select a topology. See [Selecting a Graph](#), on page 25.
- 4 Select **Configuration > Category Configurator**.

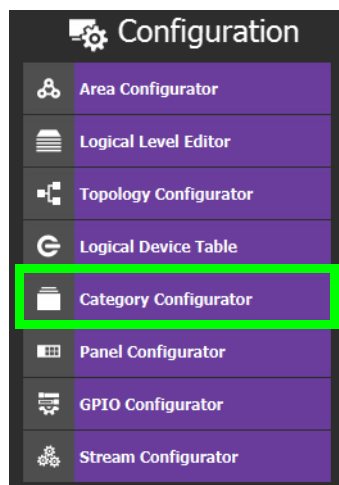

The Category Configurator task opens:

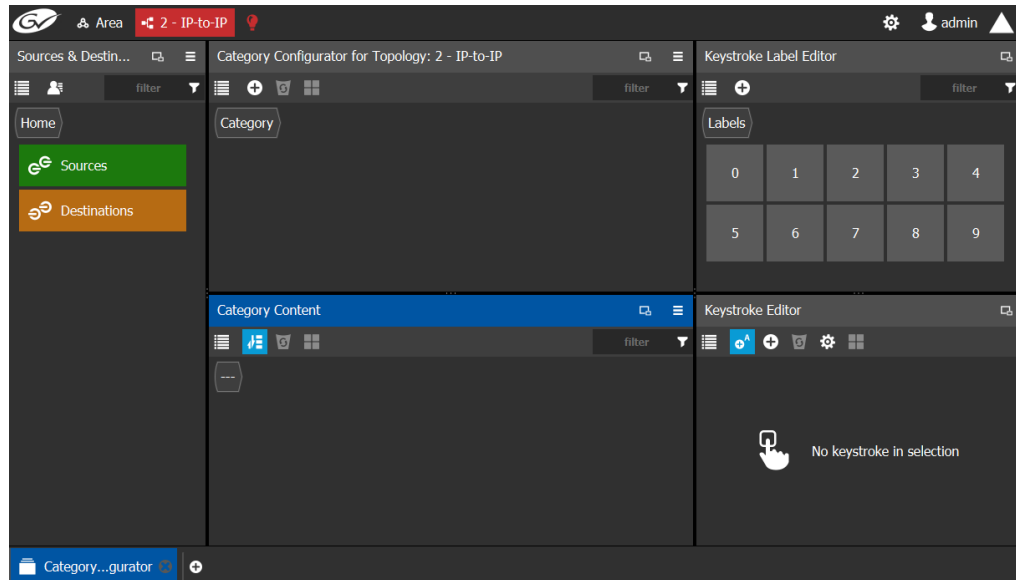



See the following Category Configurator procedures:

- [Creating Categories for the Sources and Destinations in Your Topology](#), on page 100
- [Assigning a Keystroke Label to a Source or Destination](#), on page 103
- [Creating a Keystroke Label](#), on page 104

Sources & Destinations Menu

The Sources & Destinations menu has the following menu options.

Icon	Description
 Select All	Select / deselect all source or destination items.
 Select Alias	Select the Alias you want to use to identify Source and Destination streams in GV Orbit Control's interface.

Aliases are created in the Alias Editor. See [Adding Aliases](#), on page 287.

Creating Categories for the Sources and Destinations in Your Topology

When you first open the Category Configurator, the Home tab appears in the Sources and Destinations tab.



To create a category for your sources

- 1 Open the Category Configurator task for the required topology. See [Accessing the Category Configurator](#), on page 98.
- 2 Click **Add** .

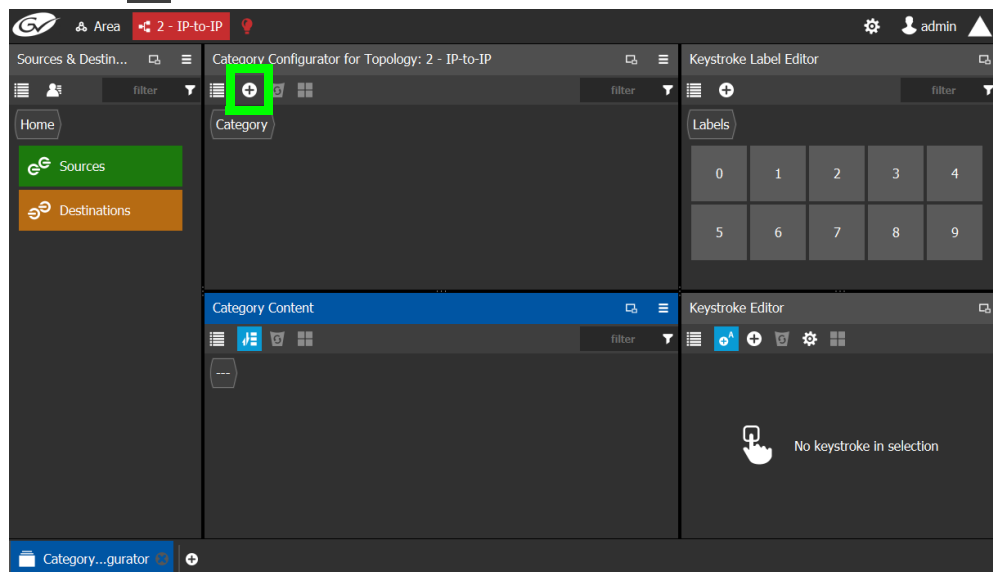

- 3 The **Enter a name for the new category** window appears:

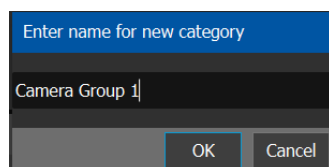

- 4 Enter a name for the new category and click **OK**.
The new category is added to the top of the **Category Configurator** column.
- 5 Click **Sources** or **Destinations** to view the available sources / destinations.
All the sources / destinations in the selected topology are displayed. This includes the logical sources you created in the Logical Device Table task. See [Logical Device Table Tasks](#), on page 72.

6 Select the newly created category.

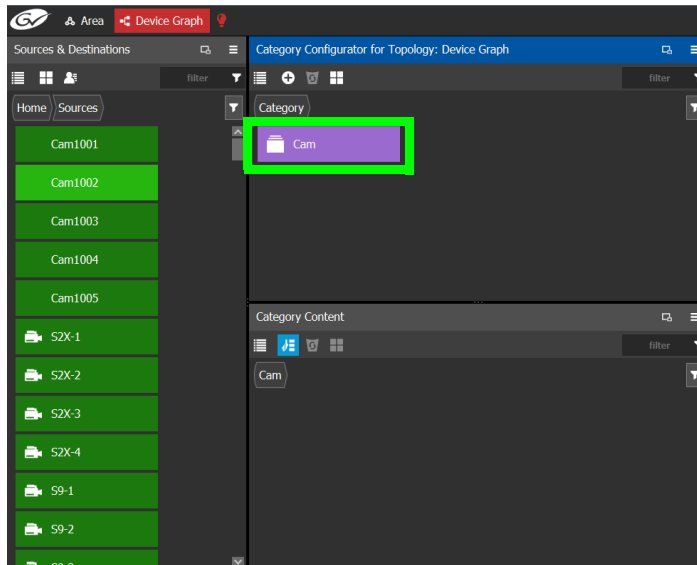

The category is added to the lower part of the center column under Category Content.

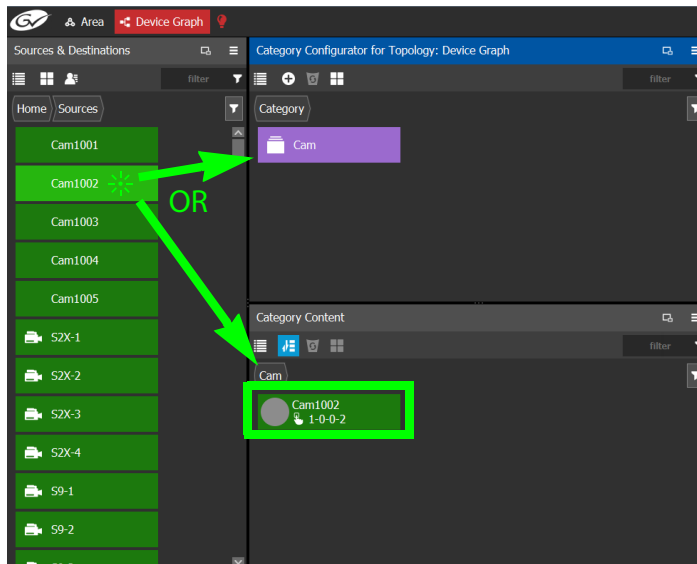

7 Drag the sources / destinations from the **Sources & Destinations** column to the Category Content area.



Alternatively, you can drag a source/destination to the created Category button. When a Category contains only Sources or it contains only Destinations, the Category's symbol will change accordingly to show the type of content. For example, this allows

you to have two Categories with the same name where one only has Sources and the other Category only has Destinations and you can still distinguish them.

Table 1: Meaning of Category Icons

Icon	Description
	The category: <ul style="list-style-type: none"> Is empty (contains no Sources or Destinations). Contains a mix of Sources and Destinations.
	The category only contains Sources.
	The category only contains Destinations.

- 8 Click Home to toggle between **Sources** (Green) or **Destinations** (Orange) as necessary.

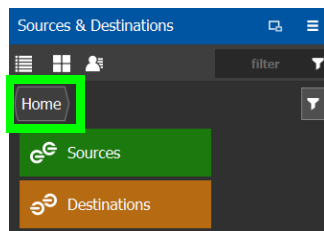

Re-ordering Category Content

The sequence of category content (Sources and Destinations) can be re-ordered so that when a category is used on a panel, the Sources and Destinations will be shown in the order that you want it to be.

- 1 Add Sources and Destinations to a Category. See [Creating Categories for the Sources and Destinations in Your Topology](#), on page 100.
- 2 Re-order the Sources and Destinations in a Category: in the Category Content, drag the Source and Destination tiles into the order you want them to be.

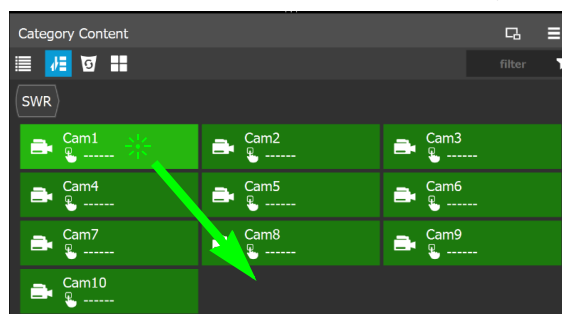

- 3 In the Panel Configurator, add a panel and configure it. See [Panel Configurator Tasks](#), on page 105.
- 4 Add the Category to a panel button. See [Adding Resources to the Panel](#), on page 117.
- 5 For each panel button you have added a Category to, select the panel button individually and set the **Sort Mode** property to **Manual** it in the button's Property Editor. See [Setting the Properties for Panel Resources](#), on page 122.

Assigning a Keystroke Label to a Source or Destination

A keystroke label can be added to sources and destinations once they have been added to a category. Assigning a keystroke label to a source or destination allows a user to bring up categories by using a keypad on a panel. For example, if you have 100 categories in your system, a panel can bring up category 37 by pressing 3 then 7 instead of browsing through dozens of panel pages. This also applies to selecting sources or destinations. For instance, Cam17 can be directly accessed by pressing 1 then 7 on the panel instead of searching for the Cam17 button.

To add a keystroke label to a source or destination

- 1 Open the Category Configurator task for the required topology. See [Accessing the Category Configurator](#), on page 98.
- 2 Click a **Category** to show sources and destinations that have been configured for that category, shown in **Category Content**.
- 3 From the Keystroke Label Editor drag one or more labels onto a source or destination to create a unique sequence for that source or destination.

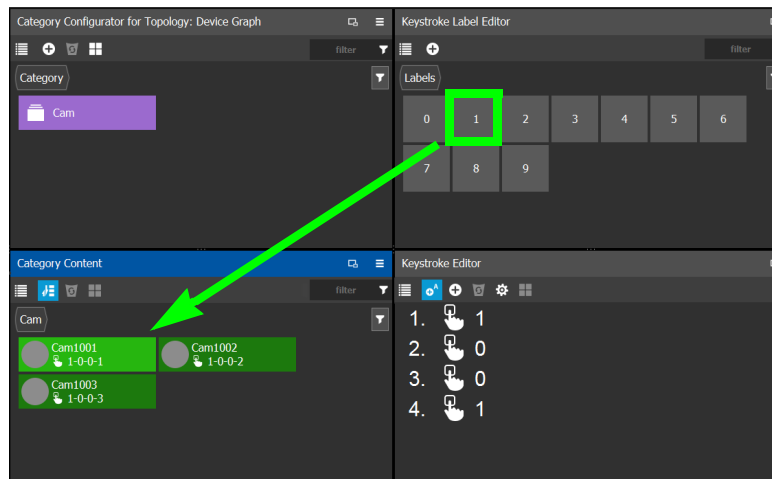

The **Keystroke Editor** shows the current keystroke label for the selected source or destination.

Edit a Source or Destination Keystroke Sequence

The **Keystroke Editor** allows you to change the selected source or destination's keystroke label. Setting for automatically assigning keystroke labels to a source or destination can also be set.

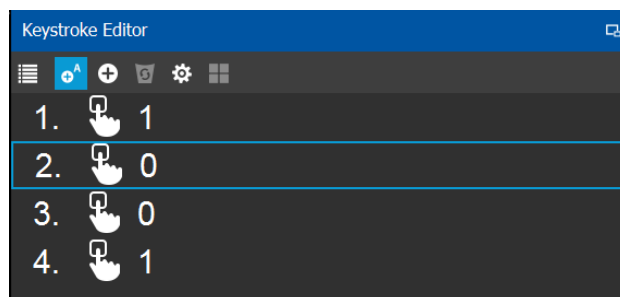

Set **Auto Add** to automatically assign a keystroke to a source or destination as it is added to a category. Click **Options** to configure this feature.

Proceed as follows to delete a keystroke.

- 1 Select a source or destination shown in **Category Content**.
- 2 Select a keystroke in the **Keystroke Editor** and click Delete.

Proceed as follows to delete all keystrokes.

- 1 Select a source or destination shown in **Category Content**.
- 2 Click **Clear All** in the **Keystroke Editor**.

Creating a Keystroke Label

You can assign custom keystrokes to a source or destination. Create a keystroke label to do so.

To creating a keystroke label

- 1 Open the Category Configurator task for the required topology. See [Accessing the Category Configurator](#), on page 98.
- 2 In the Keystroke Label Editor, click **New** .
The Create a new keystroke label window opens.

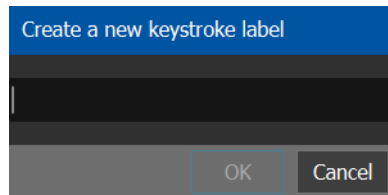

- 3 Set the keystroke label as required and click **OK**.

Panel Configurator Tasks

This allows you to add buttons and behaviors to a panel. Those buttons represent sources, destinations, levels, groups and various operations that can be saved under specific configurations and then pushed to a software or hardware panel.

For an example of how to setup and use a panel, see [Panel Configuration Example Using Categories with Custom Navigation](#), on page 132.

Accessing the Panel Configurator

To access the Panel Configurator Task

- 1 Open GV Orbit Control Stage. See [Navigating Back to Stage](#), on page 10.
- 2 Select an area. See [Selecting an Area](#), on page 23.
- 3 Select a topology. See [Selecting a Graph](#), on page 25.
- 4 Select **Configuration > Panel Configurator**.

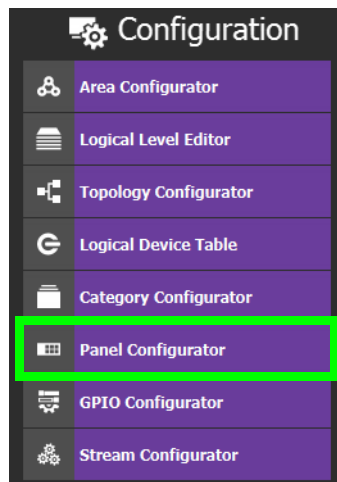



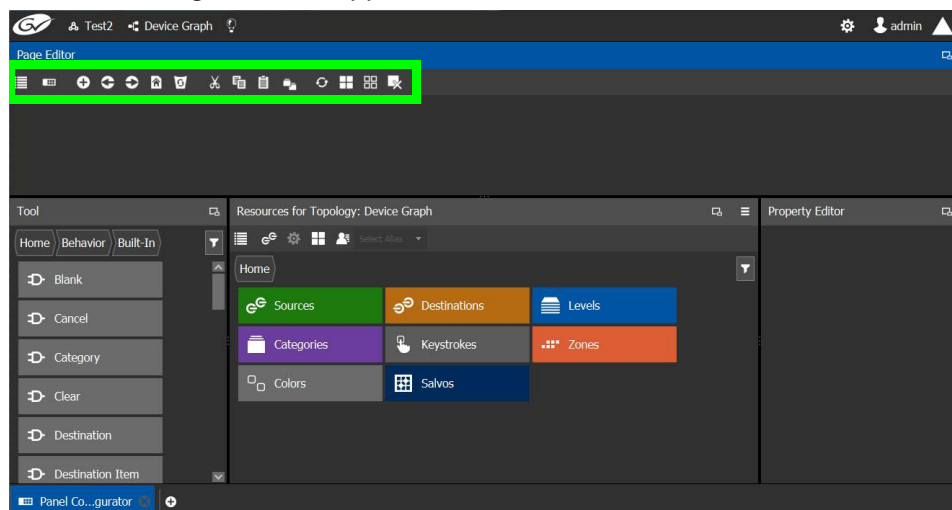











The Panel Configurator task appears:



Page Editor Menu

The Page Editor menu has the following menu options.

Icon	Description
 Manage	Creates multiple templates for hardware or software panels for various panel models. Then, you can add the template to a panel that you have added to the topology. A pre-existing panel can be duplicated; see Creating a New Panel , on page 107 or Viewing another Panel , on page 110. Using Layouts, panel layouts can be nested when used with the same panel model type. See <i>Layouts</i> in Adding Resources to the Panel , on page 117.
 Add Page	Adds a page to the panel's layout. See Adding Panel Pages , on page 113.
 Previous Page	Returns to the panel's previous page, when the panel configuration has two or more pages.
 Next Page	Goes forward to the panel's next page, when the panel configuration has two or more pages.
 Home Page	Make the currently shown page the panel's Home page. This is available when the panel's configuration has two or more pages and you currently are not on the Home page. To add panel pages, see Adding Panel Pages , on page 113. To set a page to be a panel's home page, see step 4 on page 113.
 Delete Page	Removes the currently-selected page from the panel's configuration. This is unavailable for the panel page currently designated as the Home page.
 Cut	Cuts the contents from the panel's currently selected button(s).
 Copy	Copies the contents from the panel's currently selected button(s).
 Paste	Pastes the clipboard contents to the panel's currently selected button. See About the Copy / Cut / Paste Buttons , on page 107.
 Copy Category Properties	Copies the properties of another category to the panel's currently selected category. First configure a category's properties according to your needs, and then copy the properties to other categories using this feature as needed. See Copying the Properties from one Category to Another , on page 125.
 Refresh	Reloads the Panel's contents.
 Select All	Selects all the panel's contents.
 Clear All	Deselects all the panel's contents.
 Clear	Removes all the selected panel's contents.

About the Copy / Cut / Paste Buttons

Copy / cut / paste buttons can be used from one panel page to another and from one panel to another. Copy / cut / paste can be done using either the icons in the toolbar or through keyboard shortcuts: <ctrl>+X, <ctrl>+C, and <ctrl>+V.

You can multi-select using the <Shift> / <Ctrl> key:

- By holding the <Shift> key and selecting the first and the last button/cell on the panel, all buttons/cells in between are selected. If the first and the last selected buttons/cells are in different lines, the entirety of the lines will be selected between the two buttons/cells.
- By holding the <Ctrl> key, you can toggle the selection by clicking individual buttons/cells on the panel.

Creating a New Panel

You can create multiple templates for hardware or software panels of various models. Then, you can add the template to a panel that you have added to the topology. A pre-existing panel can be duplicated; see [Viewing another Panel](#), on page 110.

To create a new panel

- 1 Open GV Orbit Control Stage. See [Navigating Back to Stage](#), on page 10.
- 2 Select an area. See [Selecting an Area](#), on page 23.
- 3 Select a topology. See [Selecting a Graph](#), on page 25.
- 4 Select **Configuration > Panel Configurator**. See [Accessing the Panel Configurator](#), on page 105.

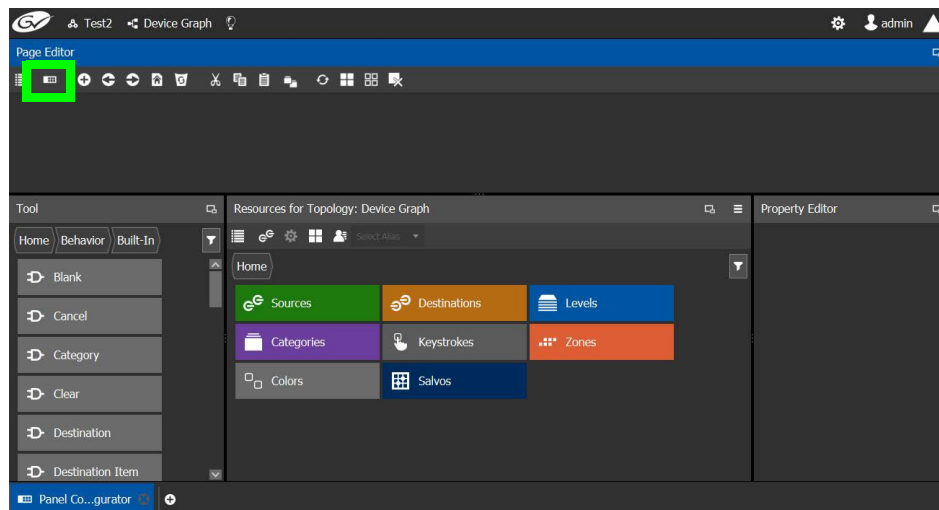

- 5 Click **Manage**.

A secondary window opens.

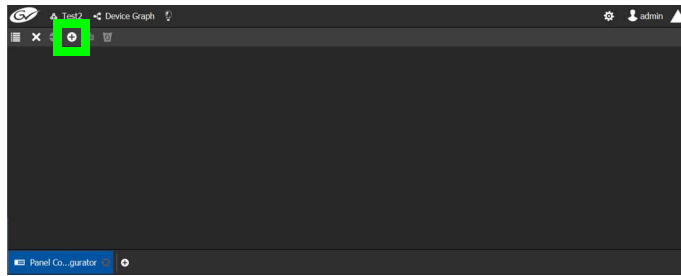

6 Click **New** .

The **New** window appears.

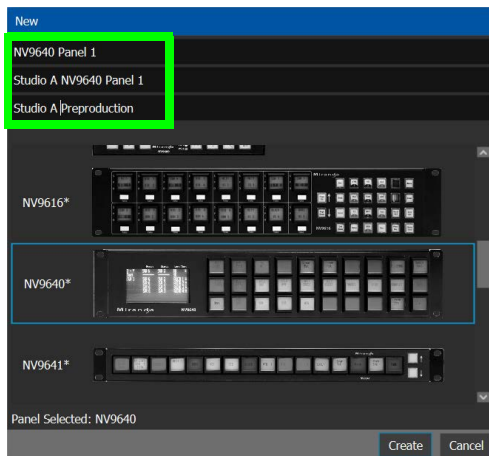

7 Enter meaningful text in the **Name**, **Summary**, and **Description** fields to identify the panel.

8 Select the required model from the list.

9 Click **Create**.

The new panel is added to GV Orbit Control.

Panels can have more than one page. When the panel is shown with a red outline, this indicates that the Home Page is being shown.

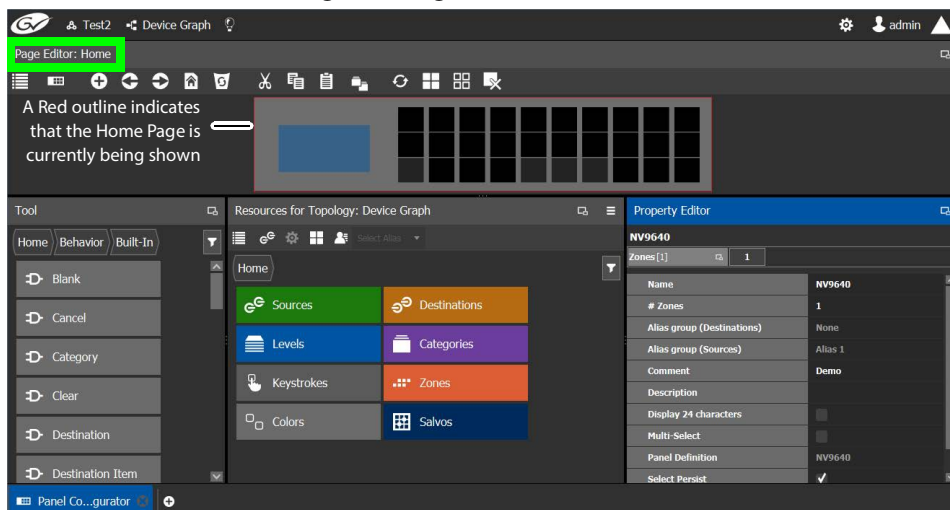

- 10 Configure the panel's properties; see [Configuring a Panel's Properties](#), on page 111.

Duplicating a Pre-Existing Panel

A pre-existing panel can be copied to reuse that panel's configuration properties and then you only need to modify the necessary panel properties as required for the new application. The new panel configuration will have a new name and any changes to that configuration will not affect the original panel configuration that you chose to base its configuration on.

To duplicate a Pre-Existing Panel

- 1 Open GV Orbit Control Stage. See [Navigating Back to Stage](#), on page 10.
- 2 Select an area. See [Selecting an Area](#), on page 23.
- 3 Select a topology. See [Selecting a Graph](#), on page 25.
- 4 Select **Configuration > Panel Configurator**. See [Accessing the Panel Configurator](#), on page 105.

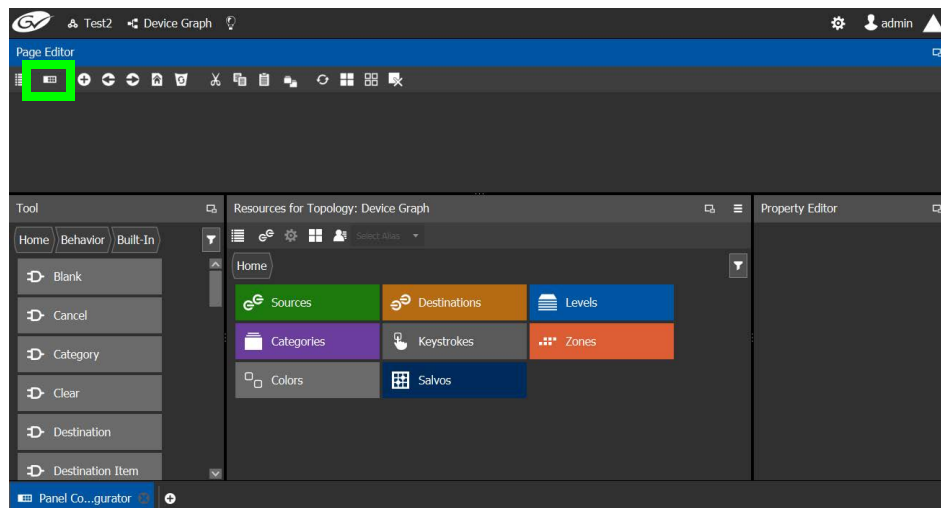

- 5 Click **Manage**.

A secondary window opens.

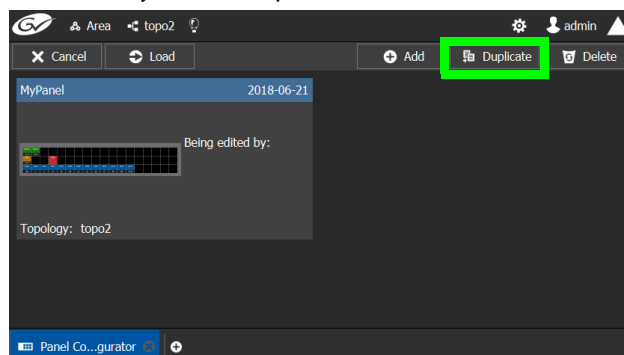

- 6 Click on a pre-existing panel that you want to duplicate and then click **Duplicate** .

The **New Name** window appears.

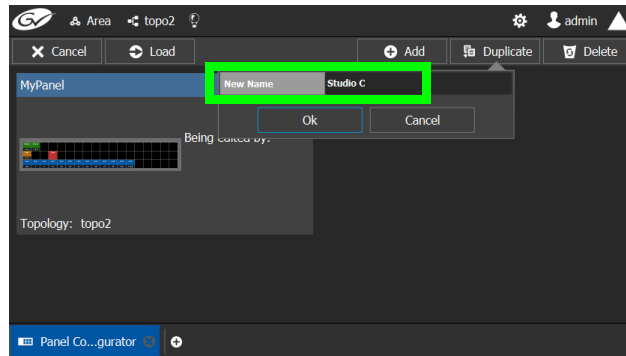

- 7 Enter a name to identify the panel.
- 8 Click **Ok**.
- 9 Configure the panel's properties; see [Configuring a Panel's Properties](#), on page 111.

Viewing another Panel

When you have configured two or more panels, you can change between configuring them as follows.

To view a Pre-Existing Panel

- 1 Open GV Orbit Control Stage. See [Navigating Back to Stage](#), on page 10.
- 2 Select an area. See [Selecting an Area](#), on page 23.
- 3 Select a topology. See [Selecting a Graph](#), on page 25.
- 4 Select **Configuration > Panel Configurator**. See [Accessing the Panel Configurator](#), on page 105.

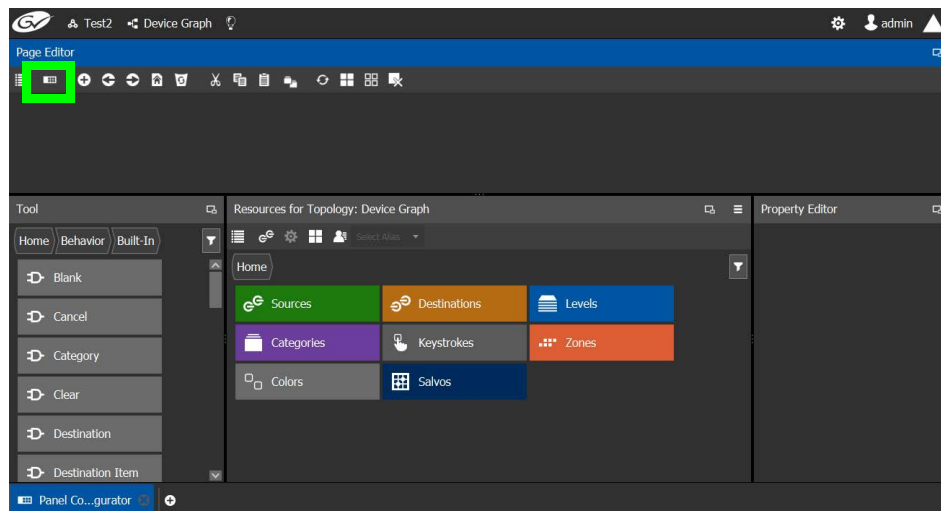

- 5 Click **Manage**.

A secondary window opens.

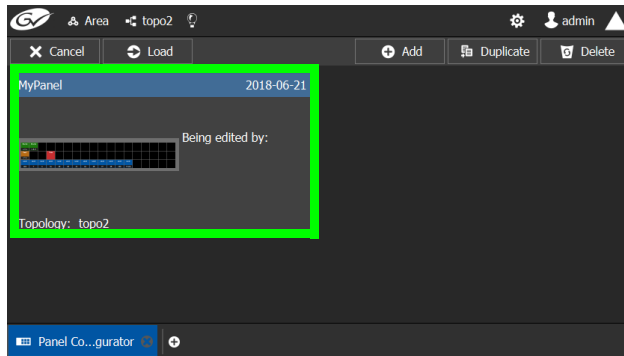

- 6 Click on a pre-existing panel that you want to view.
The configuration for the selected panel appears.

Configuring a Panel's Properties

Set the basic parameters to configure the panel.

To Configure a Panel's Properties

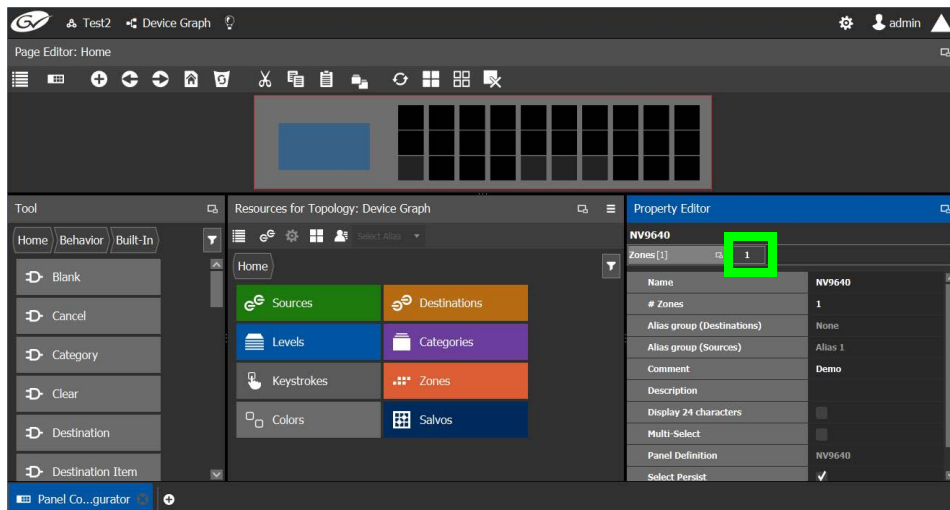

- 1 Click 1 next to Zones [1].

The following properties can be configured for the panel. See also [Description of Common Device Properties](#), on page 162.

Parameter	Description
Name	The name or identifier for this panel
# Zones	Sets the number of zones available for the selected panel. The default is 1, however you can add more as needed. Buttons can be assigned to any zone. Each zone can then act as an separate panel. For example, you can have two zones on a panel, and each zone has its own sources, destinations, and take button. Selection and take in one zone will not affect the other zone. Zones can be assigned to the button in the <i>Property Editor</i> when the button is selected in the <i>Resources for Topology</i> .
Alias group (Destinations)	Shows the currently selected destination / source alias to use on the panel button's / interface to use in place of the short labels. See Using Source and Destination Aliases with a Panel , on page 121.
Alias group (Sources)	
Comment	An optional comment about this panel.
Default Destination	Shows the currently selected default destination for this panel. See Creating a Single-Destination Work Flow Panel , on page 127.
Description	An optional description for this panel.
Display 24 characters	When deselected, panel button labels are limited to a maximum length of 8 characters. When selected, panel button labels are limited to a maximum length of 24 characters. This option is useful when using source / destination aliases that usually are longer than 8 characters. This will disable the destination status on the destination buttons. The display will only show the system names. The level buttons will only show the system names. To create source / destination aliases, see Alias Editor Tasks , on page 286. See also Using Source and Destination Aliases with a Panel , on page 121.
Multi-select	When deselected, the panel will allow multiple selection of destination buttons. This enables an operator to take a single source to multiple destinations at once. When selected, only one destination can be selected at a time.
Panel Model	The current panel's model number that was added in step 6 on page 108.
Select Persist	When deselected, the source and destination selections are cleared when a take is complete. When selected, the source and destination selections are maintained when a take is complete. This parameter is selected by default. This parameter is not zone-specific.

See also [Setting the Properties for Panel Resources](#), on page 122.

Adding Panel Pages

A panel can have one or more pages. Each page can be tailored to a function or purpose. Navigation buttons can be added to the page so the panel user can go page to page. There is more than one way for a panel user to navigate to another page; for example, see [Panel Configuration Example Using Categories with Custom Navigation](#), on page 132.

To add a panel page

- 1 View a panel. See [Viewing another Panel](#), on page 110.
- 2 Configure the panel. See [Configuring a Panel's Properties](#), on page 111.
- 3 In **Tool**, navigate to **Home > Pages** and click **Add Page** .

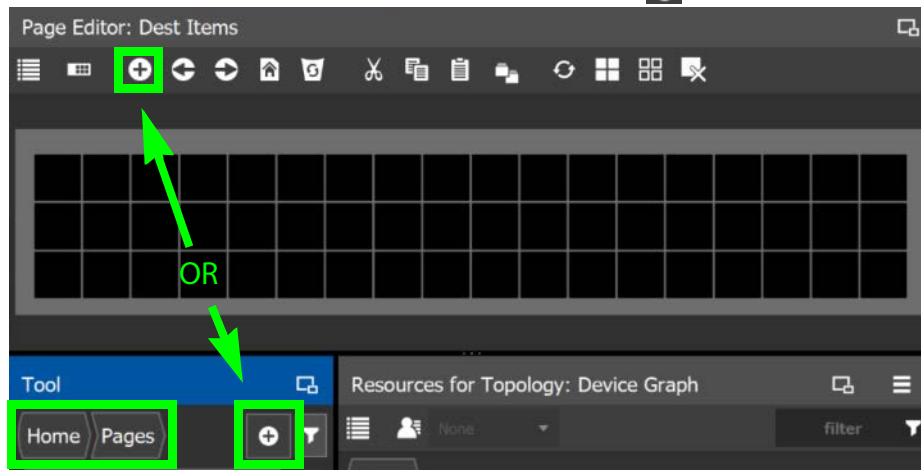

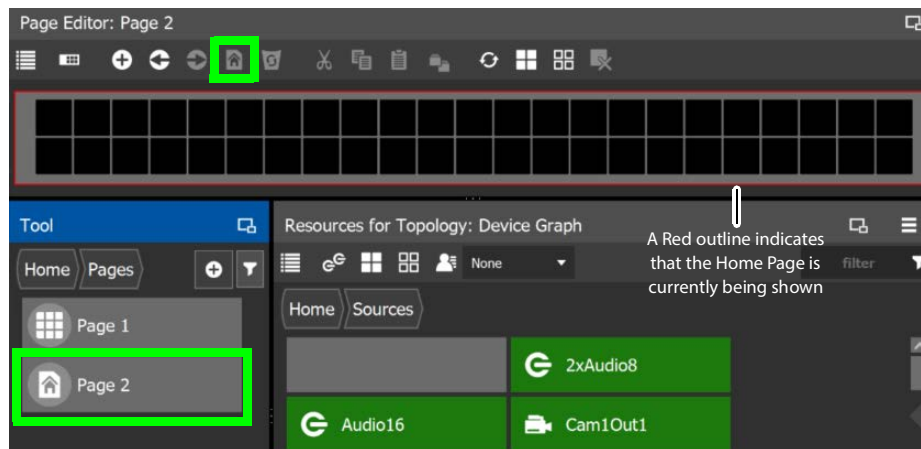

A new page is added to the **Pages** list in the **Tool** pane.

- 4 To make a panel page the Home page, select the page in **Tools** and click **Home** .



In the Tool list of panel pages, the Home icon is shown for current Home page. A red outline around the panel image indicates when the Home page is currently being shown.

Tool Page Icon	Description
	The panel page is currently not a home page.
	The panel page is currently a home page.

Adding Actions to a Panel

A panel can support a number of actions that must be added to it before the action becomes available to the panel user. For example, add a Take button to a panel as follows.

- 1 Open the Panel Configurator task for the required topology. See [Creating a New Panel](#), on page 107.
- 2 Select the required Panel.
- 3 Drag the **Take** tool from the **Tools** column onto a panel button.

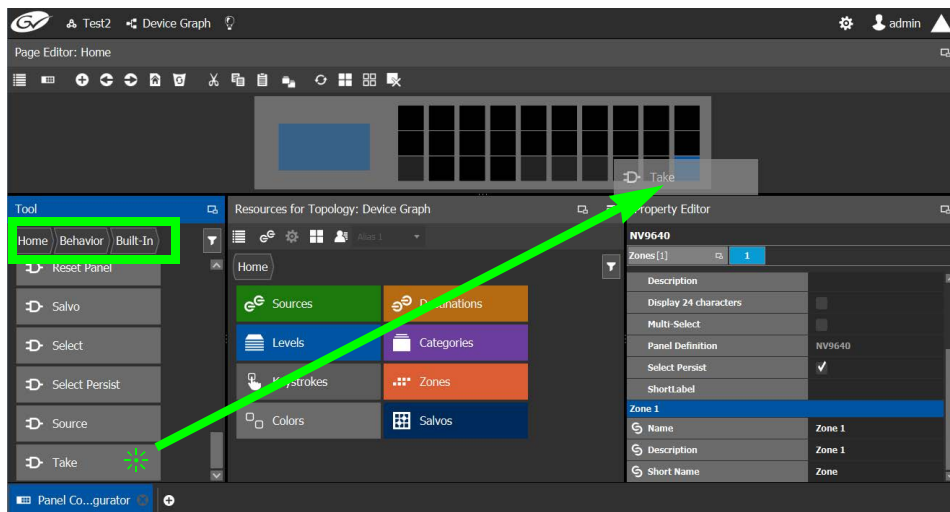

- 4 If the panel has a display, drag the **Page Up** and **Page Down** tools from the **Tools** column onto panel buttons (some panels have two dedicated buttons set apart for this purpose next to the display).

See the panel's documentation for more specific details about the behavior of panel buttons. The following table provides summary information.





Built-in Panel Actions	Description
Back	<p>Allows the panel user to go back to a previously visited page. The Back button stacks all visited pages or layout pages and will be highlighted until the panel user reaches the first page visited where the button becomes low tally. The stack of visited pages:</p> <ul style="list-style-type: none"> • Is persisted against restart, reboot and failover actions. • Is cleared when a panel user clicks a <i>Load home Page</i> button on the panel.
Blank	Some buttons can span multiple pages. This is used to force a button to appear on a higher-level page only.
Cancel	Cancels a Keystroke. Removes all keystrokes in the selection.
Category	This either (1) displays a category's device list or (2) displays a "suffix page." A category button is associated with either a source category or destination category. The button text is normally the category name and is short as space is limited.
Clear	Clears the Keystroke. Removes the last key stroke.
Default Destination	<p>Provide the tally for the default destination when the Show Tally parameter is set in the button's property.</p> <p>Set a destination to which all takes made on a panel will be made. See Creating a Single-Destination Work Flow Panel, on page 127.</p>
Destination	Select a destination.
Destination Item	This is used to do an indexed take. Use Multiple destination items to preset a multiple take. Each destination item will have a different index.
Destination Status	Provide the tally for the selected destination. See also Creating a Single-Destination Work Flow Panel , on page 127.
Indexed Take	Make a take on the Destination item.
Keystroke	Create a Keypad to select Source or Destination by their numbers.
Level	<ul style="list-style-type: none"> • Used to display the level of the destinations. • Used to display the preset of a selected level. • Used for audio Break away and audio shuffling.
Level Map	This cross-connects levels. The function is typically used to shuffle audio channels, for example, to connect AES1/2 to AES3/4.
List Item	Used in conjunction with the Category list button to create an area where the source or destination will be displayed in a list.
Load Home Page	Takes the panel user to the Home page. To set a page to be a panel's home page, see step 4 on page 113.
Load Layout	This is shown when a layout is dropped on a panel button. See <i>Layouts</i> in Adding Resources to the Panel , on page 117.



Built-in Panel Actions	Description
Load Page	Loads any panel page. To add a panel page, see Adding Panel Pages , on page 113
Lock	<p>This prevents changes to the panel settings, especially router crosspoints. When the panel is locked, the button array becomes blank except for the Panel Lock button which becomes high-tally red. The button is a toggle: press the 'Lock' button to lock the panel. Press it again to unlock the panel. The button text is either "Lock" or "Unlock."</p> <p>See also About Lock, Protect, and Release, on page 291 for more information about the use and limitations of this feature.</p>
Multi-Select	Allows the selection of multiple destinations.
Next	Continue forward to browse down a category list (this does not change the page). Normally you would not use this button directly but let the category list place it automatically, unless you need to map to a special button on a panel.
Next Page	When there are two or more pages that have been configured in the panel's layout, this cycles forward to the next panel page when available. When the panel user is at the last page, the button becomes low tally and the panel user can go no further.
Page Down	This scrolls the alphanumeric display down.
Page Up	This scrolls the alphanumeric display up.
Panel Lock	This locks the panel. When set, the panel button turns red and all other panel buttons are unavailable. Press the button again to release the lock.
Previous	Browse backwards to move up a category list (this does not change the page). Normally you would not use this button directly but let the category list place it automatically, unless you need to map to a special button on a panel.
Previous Page	When there are two or more pages that have been configured in the panel's layout, this cycles backwards to the previous panel page. When the panel user is at the first page, the button becomes low tally and the panel user can go no further.
Protect	<p>This is a toggle that sets or clears a protect on the current destination device. The protect can be removed at the panel that originally set the protect, at any panel that has the same user ID, or by a forced release at any panel.</p> <ul style="list-style-type: none"> • Note: a protect prevents others from routing to a destination; a lock prevents anyone—even the panel user who issued the lock—from routing to the destination. • You may lock a protected destination, but you cannot change a locked destination to a protected destination directly. <p>You must first unlock it. The 'Destination Protect' button text is normally Dest Protect and when a selected MD destination is protected, the button legend becomes Dest Unprotect.</p> <p>See also About Lock, Protect, and Release, on page 291 for more information about the use and limitations of this feature.</p>

Built-in Panel Actions	Description
Reset Panel	Reset the panel to its initial state and go to the home page.
Salvo	This executes a system salvo. A salvo is a pre-defined set of commands. The button text is the salvo's mnemonic. Pressing the salvo button puts the panel in "salvo" mode. To confirm that you want to execute the salvo, press a 'Take' button. When you press the take button, the salvo begins executing immediately. Salvos are typically short in duration. If you want to cancel the salvo before it executes, press the salvo button again. If you press an 'Information' button while the panel is in salvo mode, the panel presents the salvo commands on the display. You may scroll the display to view the entire salvo. See Creating Salvos , on page 293.
Select	After selecting Source or Destination from a Keypad, the panel user presses Select. This confirms the choice.
Select Persist	The destination stays selected after a Take.
Source Quick Source	This selects a source. Note that the quick source button selects a source and also performs an immediate take. Quick Source and Source buttons are similar, except that the Quick Source performs a take. Be aware of which buttons are quick sources so you do not perform an accidental take.
Take	In X-Y mode, a take button routes the preset source device(s) on selected levels to the selected destination device. In MD mode, a take button routes the preset source device(s) to the selected destination device(s) on all levels.

Adding Resources to the Panel



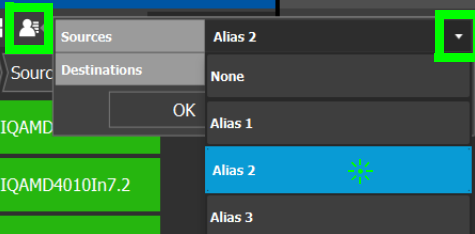

The Resources for Topology menu has the following menu options.

Icon	Description
 Quick Source	This is shown only when <i>Sources</i> is selected. When enabled, the sources that are dragged onto the panel are quick sources, meaning the operator does not need to press the take button to do the take. The take is done as soon as the source is selected on the panel.
 Default Destination	This is shown only when <i>Destinations</i> is selected. This makes the selected destination the default destination for the panel. When set: <ul style="list-style-type: none"> The panel's properties shows the currently selected destination, found under Default Destination. The icon on the destination changes to  thus indicating its default destination status. To remove the Default Destination, select the destination set as the Default Destination and click  . See Configuring a Panel's Properties , on page 111. See Creating a Single-Destination Work Flow Panel , on page 127.
 Select All	Selects all the available resources.

Icon	Description
 Clear All	Deselects all the available resources.
 Select Alias	Select the Alias you want to use to identify Source and Destination streams in GV Orbit Control's interface.
	 <p>Aliases are created in the Alias Editor. See Adding Aliases, on page 287.</p>

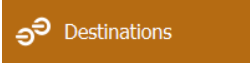
In the Tool list of panel pages, the Home icon is shown for current Home page. A red outline around the panel image indicates when the Home page is currently being

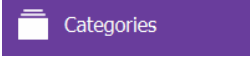
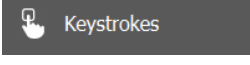
shown. From the Resources for Topology, the following resources can be dropped onto panel buttons.

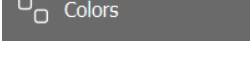
Tool Page Icon	Description
 Sources	<p>The currently configured sources. Sources are the available outputs for all the devices on your topology. See Adding a Source or Destination to the Logical Level Table, on page 79.</p> <p>Sources may be identified by an icon that represents the source type when it was automatically created as a virtual device. See About Automatic Sources or Destinations, on page 76 for more information.</p>
 Destinations	<p>The currently configured destinations. Destinations are the available inputs for all the devices on your topology. See Adding and Configuring a Destination, on page 85.</p> <p>Destinations may be identified by an icon that represents the destination type when it was automatically created as a virtual device. See About Automatic Sources or Destinations, on page 76 for more information.</p> <p>When a destination has been set to be the default destination for a panel, it is designated by the Default Destination icon . See Creating a Single-Destination Work Flow Panel, on page 127.</p>
 Levels	<p>Logical levels allow for the creation of shuffling and breakaways. For more information about logical levels, see Logical Level Editor Tasks, on page 30.</p>
 Categories	<p>Shows the available categories. See:</p> <ul style="list-style-type: none"> • Table Category Configurator Tasks on page 98. • Table 1 Meaning of Category Icons on page 102. • Panel Configuration Example Using Categories with Custom Navigation, on page 132
 Keystrokes	<p>A keystroke label can be added to sources and destinations once they have been added to a category. See Assigning a Keystroke Label to a Source or Destination, on page 103.</p>
 Zones	<p>Click a zone to see which panel buttons are assigned to that specific zone. The number of zones is set in the # Zones parameter in the panel properties. See Configuring a Panel's Properties, on page 111.</p>
 Colors	<p>Some panel buttons support the display of more than one color. For buttons that support colors, the button's color is used to show the current operating state. The color used for a button to represent any one of the given states can be changed. See Changing a Button's Color used to Represent a State, on page 125 and Changing a Button's Default Color used to Represent a State, on page 127.</p>

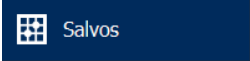
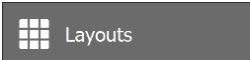
Tool Page Icon	Description
	When a salvo is triggered, it executes a list of pre-configured actions. See Creating Salvos , on page 293.
	<p>Allows a panel to be used as a template to then be used in another panel. Making changes to the template panel will be seen everywhere the template is used. When:</p> <ol style="list-style-type: none"> 1 You have created two or more panels with the same model type (for example, you have added three NV6954 panels in the Panel Configurator), 2 And you are viewing a panel with the same model type (for example, one of the three NV6954 panels in the Panel Configurator). <p>Then:</p> <ul style="list-style-type: none"> • These model types become available in this list (excluding the current panel). To create a panel, see Creating a New Panel, on page 107. • A panel from the Layouts can be drag and dropped onto the current panel layout to be reused. This creates a <i>Load Layout</i> button on the panel. <p>Select the <i>Load Layout</i> button to configure its properties in the <i>Property Editor</i>. See Setting the Properties for Panel Resources, on page 122.</p>

To add panel resources

- 1 Open the Panel Configurator task for the required topology. See [Creating a New Panel](#), on page 107.
- 2 Select the required Panel. See [Viewing another Panel](#), on page 110.

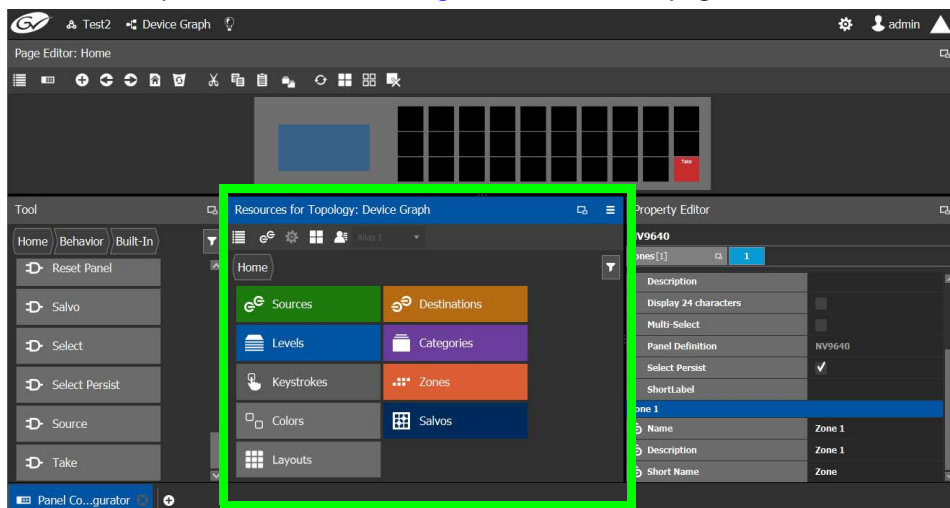

The resources that can be added to the panel are displayed in the lower section of the center column under **Resources for Topology**.

- 3 Click on resource type to begin adding individual resources to the panel such as **Sources**, **Destinations**, or **Levels**.

For example, click **Sources** to add cameras and other types of sources.

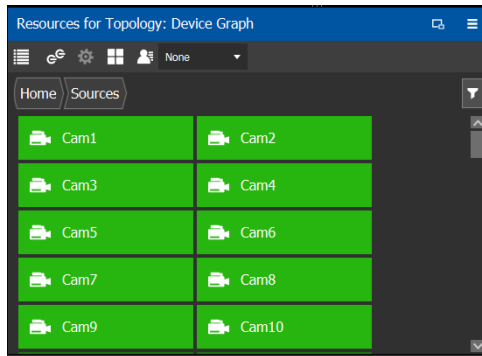

All the sources available in the topology are listed. This includes the logical sources you created in the Logical Device Table task. See [Logical Device Table Tasks](#), on page 72.

- 4 Select a resource and drag it to one of the panel buttons at the top of the column. More than one resource can be added at a time; to add to a selection, use *Shift* or *Ctrl* to select a range of resources or to add another resource to the selection.

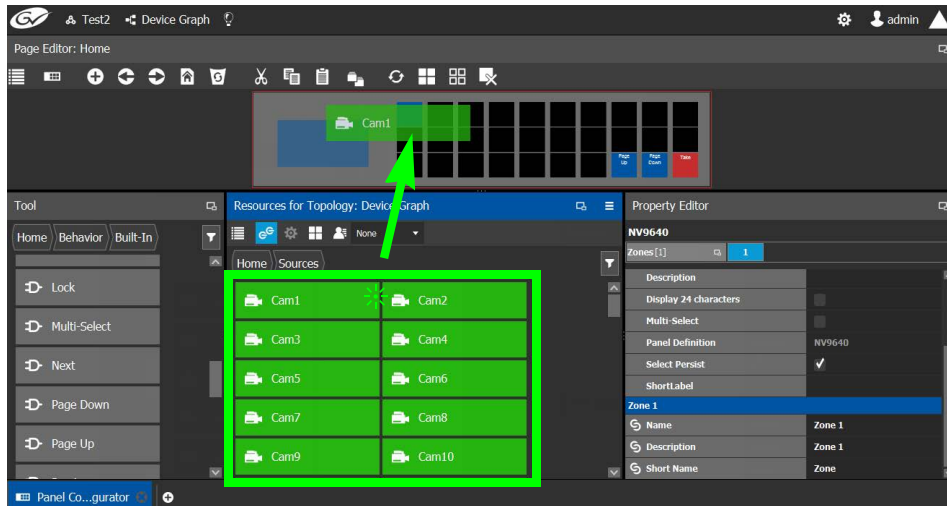

- 5 For each panel button you have added a resource to, select it individually and set the properties for it in the Property Editor. For a Category, see [Setting the Properties for Panel Resources](#), on page 122.
- 6 Add resources from **Destinations**, **Levels**, and **Keystrokes** to the panel as required.

Note:

Only use the video+ancillary (V-ANC) logical level button unless you are routing in SMPTE ST 2110 mode. For SMPTE ST 2110 mode, you can individually use the Video or the Ancillary logical level buttons.

To directly control a GV Node's internal matrix, you must use the video + ancillary logical level button for video breakaway.

Using Source and Destination Aliases with a Panel

Aliases can be used for a panel to change the name of sources and destinations from short labels to the labels of the corresponding alias. First you must create one or more source and destination aliases; to create an alias, see [Alias Editor Tasks](#), on page 286.

- 1 Under **Resources for Topology**, click **Sources** or **Destinations**.
- 2 Select from the **Select Alias** drop-down list the alias to use for this panel instance.

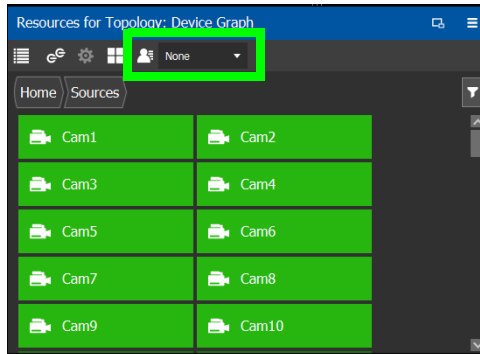

- 3 If the aliases are longer than 8 characters, consider setting the **Display 24 characters** option for the panel in the Panel's **Property Editor**. See [Creating a New Panel](#), on page 107.

Setting the Properties for Panel Resources

When a resource has been added to a panel's button, you can select the button to then configure the properties for it.

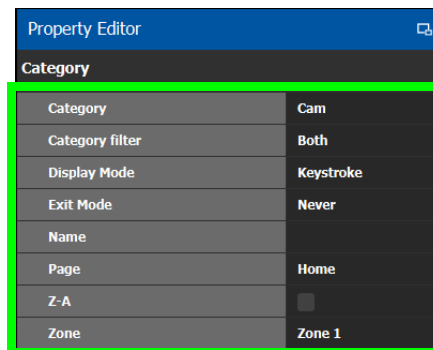

Parameter	Description
Category	Selects the category instance for the selected button. Typically this should be the category that was dragged onto the panel in Resources for Topology. It can be changed here for another category.
Category filter	A category can contain sources and/or destinations. Select the ones you want to be displayed. Both: display sources and destinations. Destinations: display destinations only. Sources: display sources only.
Display Mode	Keystroke: if the category item has keystrokes assigned to it, you can select this option. List: if not select List; this will list all sources/destinations in the category.

Parameter	Description
Exit Mode (for Load Layout, when a panel is used as a template)	<p>Select how the panel user will be returned from a panel layout once they have made a category item selection or Take. The category item selection is displayed once the panel user has pressed the category selection button.</p> <p>Never: The panel user will remain in the same page where the category item selection is made. Other navigation buttons must be added to the page so that the panel user can navigate from the page (such as the Back button and / or the Previous Page and Next Page buttons).</p> <p>Preset: Once the panel user has made a selection in the category items, the panel user is immediately returned to the previous page (where the category selection button is located).</p> <p>Take: When the category items page has a Take button, the panel user is returned to the previous page (where the category selection button is located) once they select a category and then click Take.</p> <p>See Panel Configuration Example Using Categories with Custom Navigation, on page 132 for an example of how to use this parameter.</p>
Exit Mode (for category item selection)	<p>Select how the panel user will be returned once they have made a category item selection or Take. The category item selection is displayed once the panel user has pressed the category selection button.</p> <p>Never: The panel user will remain in the same page where the category item selection is made. Other navigation buttons must be added to the page so that the panel user can navigate from the page (such as the Back button). With this option, the Exit Page parameter below is not applicable.</p> <p>Preset: Once the panel user has made a selection in the category items, the panel user is immediately returned to the previous page (where the category selection button is located). This is the default. With this option, the Exit Page parameter can send the panel user to any other page (see below).</p> <p>Take: When the category items page has a Take button, the panel user is returned to the previous page (where the category selection button is located) once they select a category and then click Take. With this option, the Exit Page parameter can send the panel user to any other page (see below).</p> <p>See Panel Configuration Example Using Categories with Custom Navigation, on page 132 for an example of how to use this parameter.</p>

Parameter	Description
Exit Page (for category item selection)	<p>In conjunction with the Exit Mode parameter, this parameter changes the Preset and Take return navigation to any other panel page. This can be used to save the panel user from making extra panel presses to navigate back to the Home page, for example.</p> <p>In order to use this feature the Exit Mode must be set to Preset or Take. See above.</p> <p>When the value for this parameter is blank (empty), the Exit Page parameter has no effect. This is the default.</p> <p>When the value for this parameter is a panel's page, the panel behavior is to take the panel user to the selected panel page once they have pressed the category item selection or Take button. See Panel Configuration Example Using Categories with Custom Navigation, on page 132 for an example of how to use this parameter.</p>
Layout	Set the panel to be associated to the Load Page button.
Name	Set the name that will appear in the category button instead of the category name.
Page	Sets the page to display when the category button is pressed. It should typically contain either List Item buttons or Keystroke buttons.
Sort Mode	<p>If the list display mode is selected, this will:</p> <p>A-Z: show the sources/destinations in alphabetical order.</p> <p>Manual: show the sources/destinations in the order you have set for the Category. see Re-ordering Category Content, on page 102.</p> <p>Z-A: show the sources/destinations in reverse alphabetical order.</p>
Next	<p>These options are present for the List Item buttons. If the list of sources/destinations in the category is greater than the number of list item buttons added to the page, some buttons will be used as next or previous buttons. This is determined automatically by GV Orbit Control, but you can override the default by specifying that a button can be used as a next or previous button if need be.</p>
Previous	
Keystroke	This parameter is available with the Keystroke button. It specifies the keystroke associated with the button.
Zone	<p>Select the zone for the category button.</p> <p>Buttons can be assigned to any zone. Each zone can then act as an separate panel. For example, you can have two zones on a panel, and each zone has its own sources, destinations, and take button. Selection and take in one zone will not affect the other zone. Zones can be assigned to the button in the <i>Property Editor</i> when the button is selected in the <i>Resources for Topology</i>.</p>



Copying the Properties from one Category to Another

Copies the properties of the panel's currently selected category to one or more other categories used on the panel. The scope (the type of parameters) of the copy can be controlled.

To copy the Properties from one Category to Another

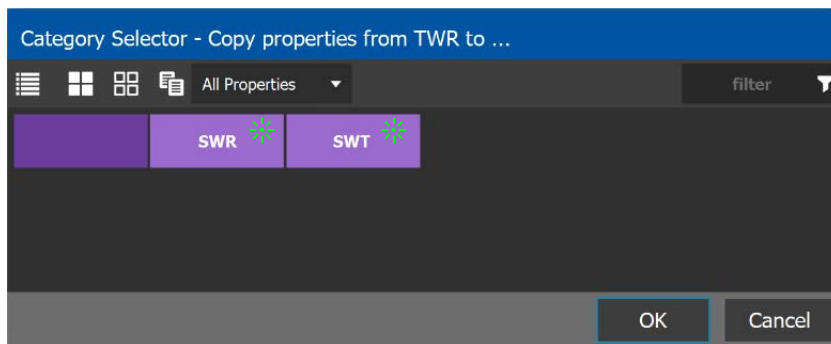
- 1 Add two or more categories to the panel. See [Adding Resources to the Panel](#), on page 117.
- 2 Configure the properties of one of the categories according to your needs. See [Setting the Properties for Panel Resources](#), on page 122.
- 3 Select the category from which you want to copy the properties from.
- 4 Click  **Copy Category Properties** to copy the properties of the selected category to other categories.



Icon	Description
 Select All	Selects all the available categories.
 Clear All	Deselects all the available categories.
 Property to copy	Select from the dropdown list the property parameter field you want to copy. <ul style="list-style-type: none"> • All Properties: Copy all the following properties to the selected categories: Display Mode, Exit Mode, Page, Category Filter, Zone, and Sort Mode. • Display Mode, Exit Mode, Page, Category Filter, Zone, and Sort Mode: This allows you to copy only a specific property parameter while leaving the remaining property parameters for the categories untouched. For more information about these category property parameters, see Setting the Properties for Panel Resources , on page 122.

- 5 Select one or more categories to which you want to copy the properties to. Click **OK**.

Changing a Button's Color used to Represent a State

Some panel buttons support the display of more than one color. For buttons that support colors, the button's color is used to show the current operating state. The color used for a button to represent any one of the given states can be changed as follows.

- 1 Click a button that has a behavior previously associated to it (a blank button will not work). See [Adding Actions to a Panel](#), on page 114 and [Adding Resources to the Panel](#), on page 117.

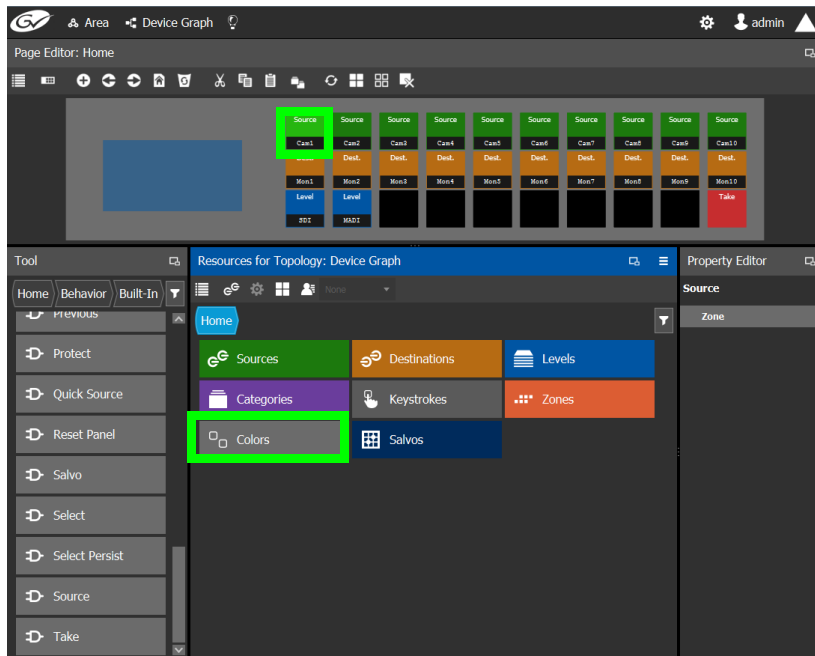

- 2 Click on the **Colors** resource type.

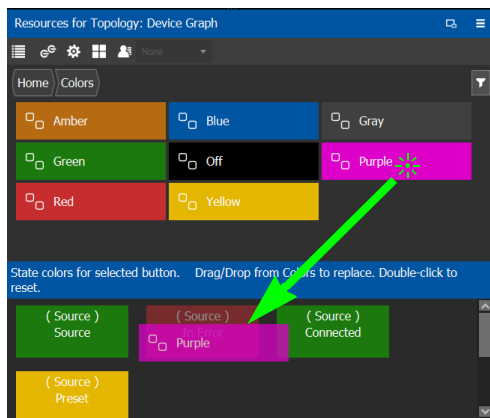

All available state colors for the selected button are shown on the lower half.

- 3 Drag a color from the color pallet (shown on the upper half) onto any one the state colors on the lower half.

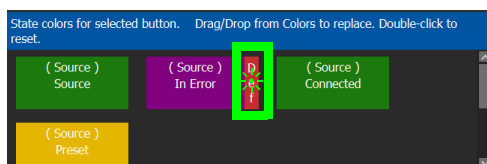

A *Def* bar appears on the state color which indicates the default color. Double-click the state color to revert to this default color.

Changing a Button's Default Color used to Represent a State

The default color used by all buttons for a behavior state can be changed when an across the system change is necessary.

- 1 Click the Custom Color Settings icon .
- 2 Click a behavior that you want to configure, for example, *Destination*.

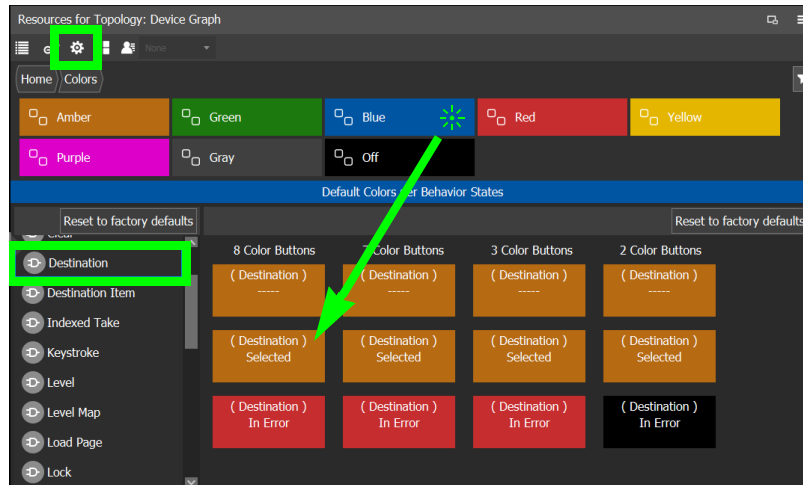

- 3 Drag a color from the color pallet (shown on the upper half) onto any one the state colors on the lower half.

Certain panel buttons support fewer colors. The 7, 3, and 2 Color Buttons columns will show how your color choice will be implemented for these reduced color-range buttons.

Creating a Single-Destination Work Flow Panel

A panel can be configured as an input selector: the panel shows a range of sources, from which the panel operator can choose from, and the selected source will always be routed to a single specific, pre-defined static destination for monitoring. Note that in this example, there are no destination buttons defined on the panel.

To create a single-destination work flow panel



This example shows how to create a single-destination work flow panel.

- 1 Create a new panel. See [Creating a New Panel](#), on page 107.
- 2 Add the sources and a Lock and Take buttons to the panel. See [Adding Resources to the Panel](#), on page 117 and [Adding Actions to a Panel](#), on page 114.

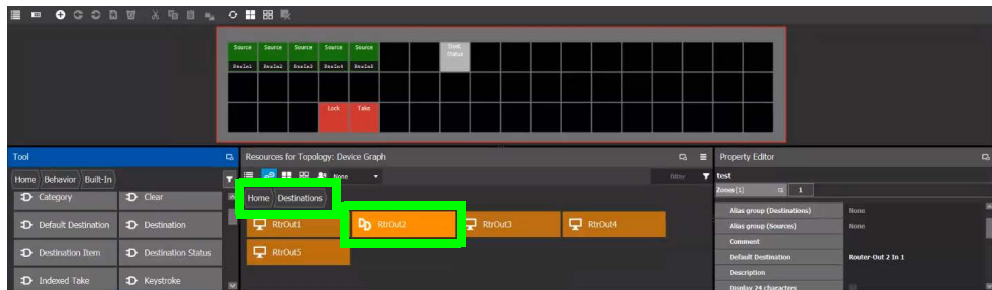

- 3 Select the destination to which all sources will be routed for this panel: In **Resources for Topology, Destinations**, select a destination to which any selected source will be sent.



- 4 Set this destination as the default destination: click **Default Destination** . The icon on the destination changes to .

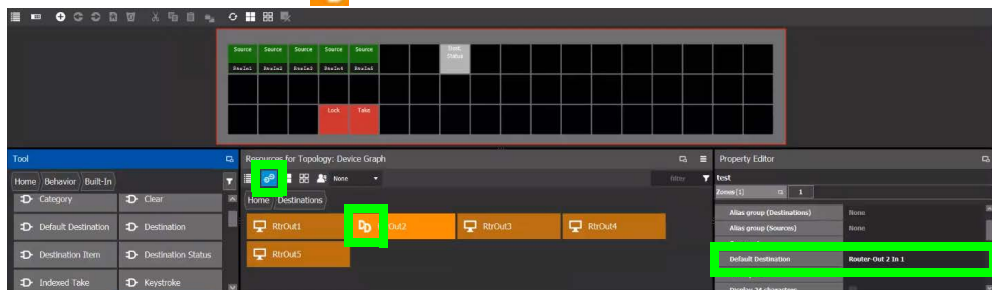

In the panel properties, the **Default Destination** parameter shows the selected destination as its value.

- 5 On the **Home** page, add a **Destination Status** from the **Built-In** Tool to a panel button. This panel button provides the tally of the default destination to the panel operator. See [Adding Actions to a Panel](#), on page 114.

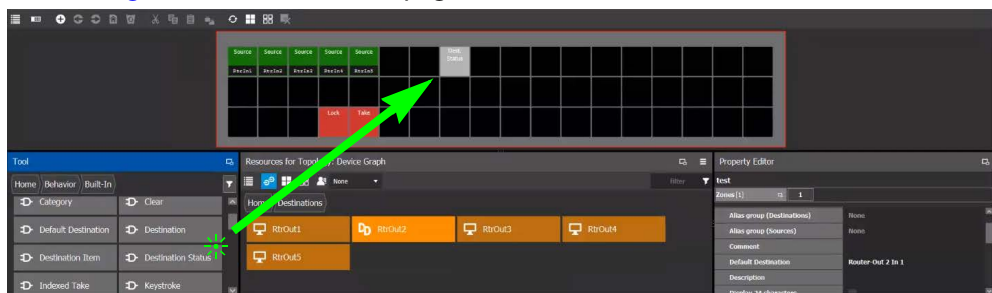

The panel operator can now select a source that will be routed to the **Router-Out 1 In 1** destination. The **Destination Status** button updates with the current tally for the destination.

Adding the New Panel to the Topology

After you have configured one or more templates for your software or hardware panels, you can add a panel to your topology.

To add a panel to the topology

- 1 Add the Panel to the Topology: from the **Device Library, Virtual Device**, find the Panel bubble. See [To add a Virtual Device to a topology](#), on page 44.

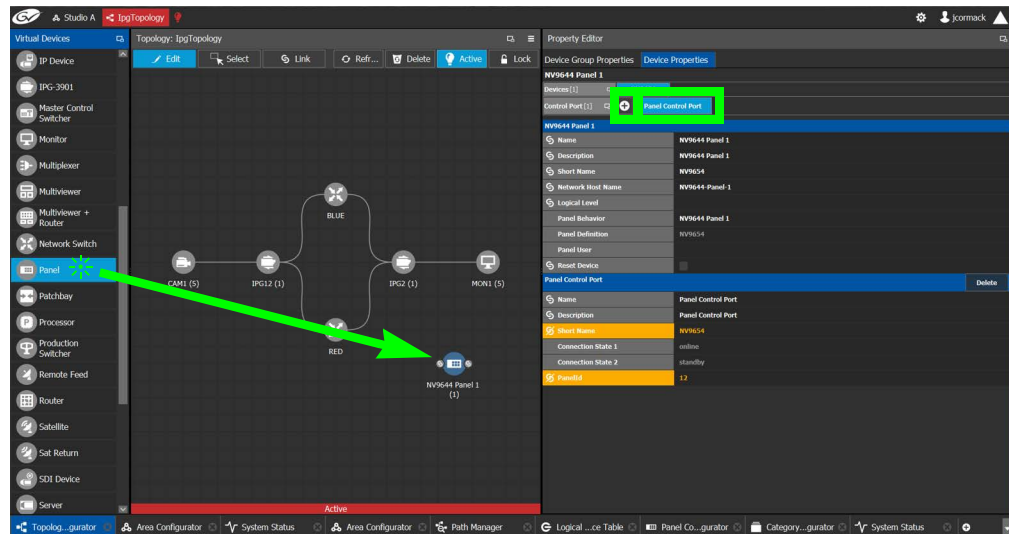

- 2 Select the bubble for the panel device to configure the panel's Device Group Properties in the **Property Editor**. See also [Description of Common Device Properties](#), on page 162.

Parameter	Description
Name	The name or identifier for this panel instance.
# Devices	The number of panel instances in this device group.
Network Host Name	When one or more panels are managed by DCNM through the media network, set a unique network identifier for these panels so as to be able to push policies to them.
Advanced > Description	An optional description for this panel's control port.
Advanced > Logical Level	The logical level for this panel. See Logical Level Editor Tasks , on page 30.
Advanced > Default Connector Type	The panel's connector type.

- 3 Select **Device Properties** and click **New**  next to **Control Port** at the top of the **Property Editor** and select **NV96XX Panel Control** from the list.

The **Panel Control Port** tab appears. See also [Description of Common Device Properties](#), on page 162.

Parameter	Required ^a	Description
Name		The name or identifier for this panel instance.
Description		An optional description for this panel instance.
Logical Level		The logical level for this panel. See Logical Level Editor Tasks , on page 30.
Panel Layout	•	Select the name of the panel you used when you created the panel (see Creating a New Panel , on page 107) from the drop-down list.
Panel Model		When you have selected the <i>Panel Layout</i> parameter, this is the panel's model number that was selected when you created the panel. It is read-only.
Panel User	•	Select the panel's user name from the drop-down list. For further information, see Administration Tasks , on page 297. A panel <i>Admin</i> or <i>Operator</i> user has the ability to release locks made by another user. Whereas non-Admin or non-Operator users can only release locks they made themselves. Destinations Lock/Protect is performed through the panel and if a destination is currently locked by another user, any take to this same destination will fail. If a specific router port is locked/protected but not linked to any destination within the Control System, the Lock/Protect status won't be exposed in the Control System and in fact is not releasable. See also About Lock, Protect, and Release , on page 291 for more information.
Reset Device		When the topology is inactive (see Making an Active Topology Inactive , on page 67), click to reset the device.

a. This parameter must be configured in order for the panel to become functional.

4 Select **Panel Control Port** tab to make the following properties visible. See also [Description of Common Device Properties](#), on page 162.

Parameter	Required ^a	Description
Panel Control Port > Name		The panel's control port name.
Panel Control Port > Description		An optional description for this panel's control port.

Parameter	Required ^a	Description
Panel Control Port > Connection State 1 / 2		Connection State 1 shows the connection status of the panel with the primary server of a server group. Connection State 2 shows the connection status of the panel with the secondary server of a server group. See Configuring a Controller Group , on page 19. unknown: the topology is inactive (see Activating a Topology , on page 66) or the panel does not have network connectivity to the GV Orbit Server(s). offline: the panel does not have network connectivity to the GV Orbit Server(s). online: the panel is connected to the GV Orbit Server(s).
Panel Control Port > PanelID	•	Each control panel must have been configured with a unique Panel ID number. Enter the Panel ID that corresponds with the physical panel that is to be used with this panel instance.

a. This parameter must be configured in order for the panel to become functional.

- In the hardware or software panel, ensure you have configured the Panel ID number and the Controller 1 IP address. For a software panel, set **Connect**.

When the panel is online, you can control GV Orbit Control from the panel.

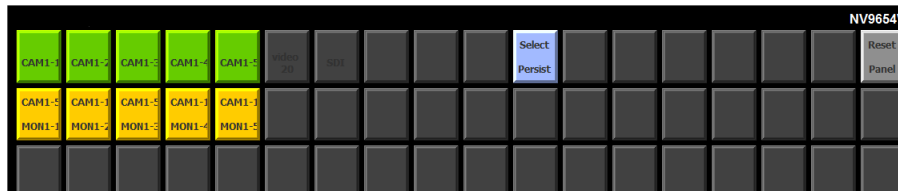

You can view the health of the panel in the System Status task. See [System Status Task](#), on page 277.

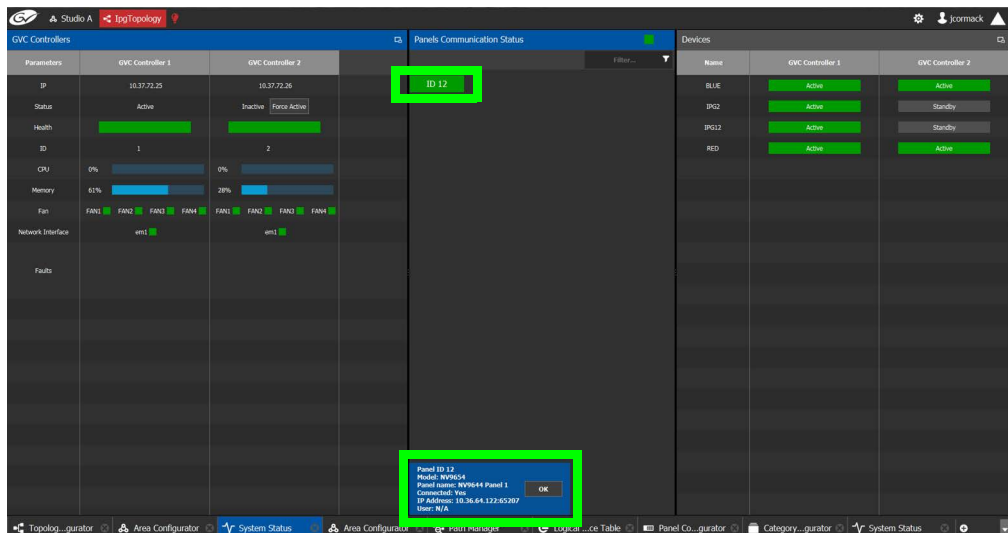

The green bar indicates the health of the panel is good.

- Click the Panel ID at the top of Panel Communication Status column to view data on the panel. This appears at the bottom of the interface.

Panel Configuration Example Using Categories with Custom Navigation

This panel configuration example shows how to:

- Set panel navigation when using categories.
- Generally configure a panel.

For this example, the following panel page structure is used. The goal of this example is to teach you how to configure the panel so that the panel user has a work flow with the least number of panel navigation button presses (that is, the need to use *exit*, *return*, or *home* button presses has been minimized).

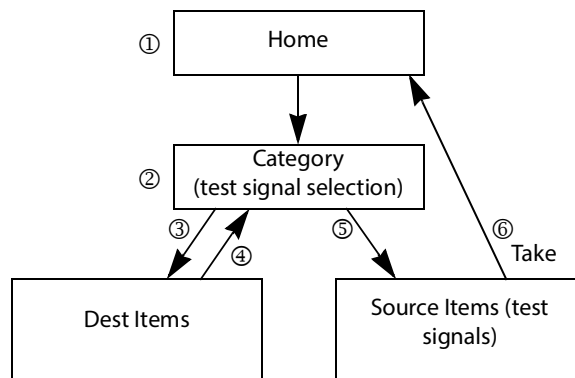

Panel Page Structure and Panel User Navigation Steps for this Example

The following steps outline panel navigation button presses used for this example. See the circled numbers in the above diagram.

Step	Panel User Button Press	Description
1	Category	On the panel's Home page is: <ul style="list-style-type: none"> • Is a range of sources and destinations, plus a Take button for normal routing activities. • A Category button (test signal selection) that allows the panel user to route a test signal to a destination using categories.
2	Dest Items	On the panel's Category page (test signal selection) are Dest Items and Source Signals buttons (test signals). The panel user presses Dest Items .
3	Select a destination	A selection of five destination category items are shown in the Dest Items page. The panel user presses a button to select a destination to which a test signal will be sent. The panel user is returned to the panel's Category page.
4	Source Items	On the panel's Category page (test signal selection) are Dest Items and Source Signals buttons (test signals). The panel user presses Source Items .
5	Select a source and then Take	A selection of five source category items (test signals) are shown in the Source Items page. The panel user presses a button to select a source (test signal) and then presses TAKE .
6	–	Once the Take is made in the Source Items page, the panel's configuration navigates the panel user to the Home page where the panel user is ready to continue with other operations.

About panel user navigation in this example

Note that *no up, home, or return* navigation buttons are used in this example. In practice, a panel's configuration should include navigation buttons as an answer to when a panel user changes their mind and no longer wants to commit to an action. In this example, a panel user must complete the action once started; there is no escape function to exit the above procedure part way through. This is solved by adding a *Load Page* action to a panel button and configuring the action to take the panel user to the **Home** Page for example. See [Adding Actions to a Panel](#), on page 114.

To configure this example

Proceed as follows.

- 1 Create the following topology that is used for this example.

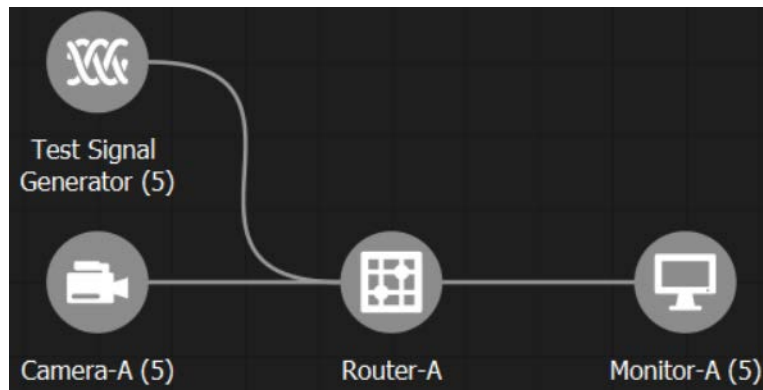

Add to the Topology Configurator the following device groups: 5 Test Signal Generators, 5 cameras, 5 monitors. Then add a router with 10 inputs and 5 outputs to the Topology Configurator. See [Adding Devices to a Topology](#), on page 44 and [To name a device and set the number of devices in the group](#), on page 45.

- 2 Click Quick Connect to link the devices together. See [Using Quick Connect to Link all Devices in a Topology](#), on page 53.
- 3 In the Category Configurator, Create the categories you will use with the panel. See [Creating Categories for the Sources and Destinations in Your Topology](#), on page 100. For this example, five test signal sources have been added to the **Source** Category (shown) and five destinations have been added to the **Destination** Category (not shown).

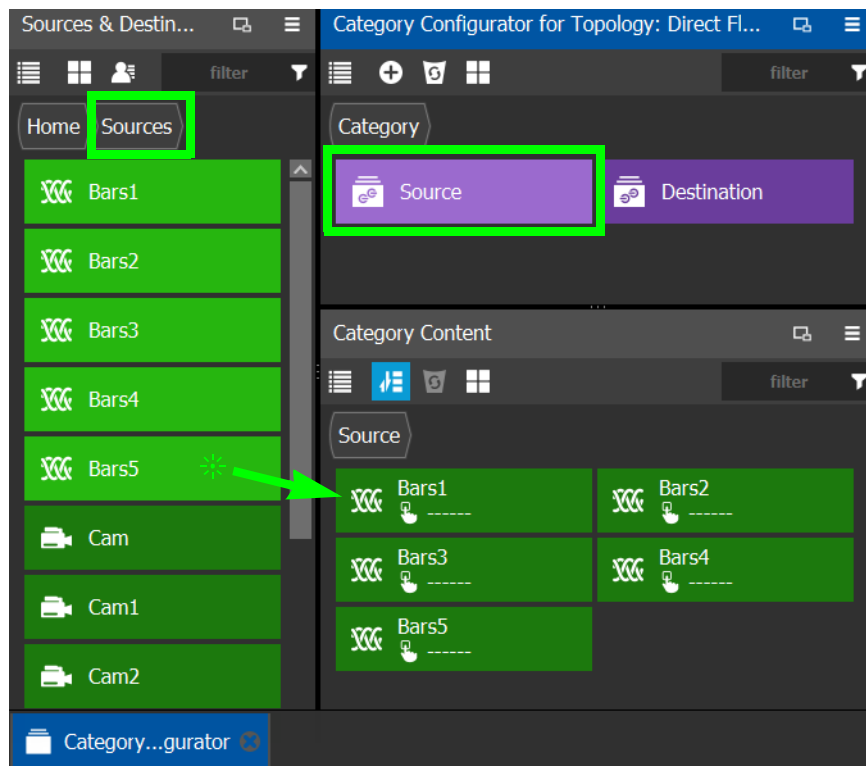

- 4 Create a panel if you have not already done so. See [Creating a New Panel](#), on page 107.
- 5 Configure the panel's properties. See [Configuring a Panel's Properties](#), on page 111.

- 6 Add the following pages to the panel: **Category**, **Source Items**, and **Dest Items**. See [Adding Panel Pages](#), on page 113.

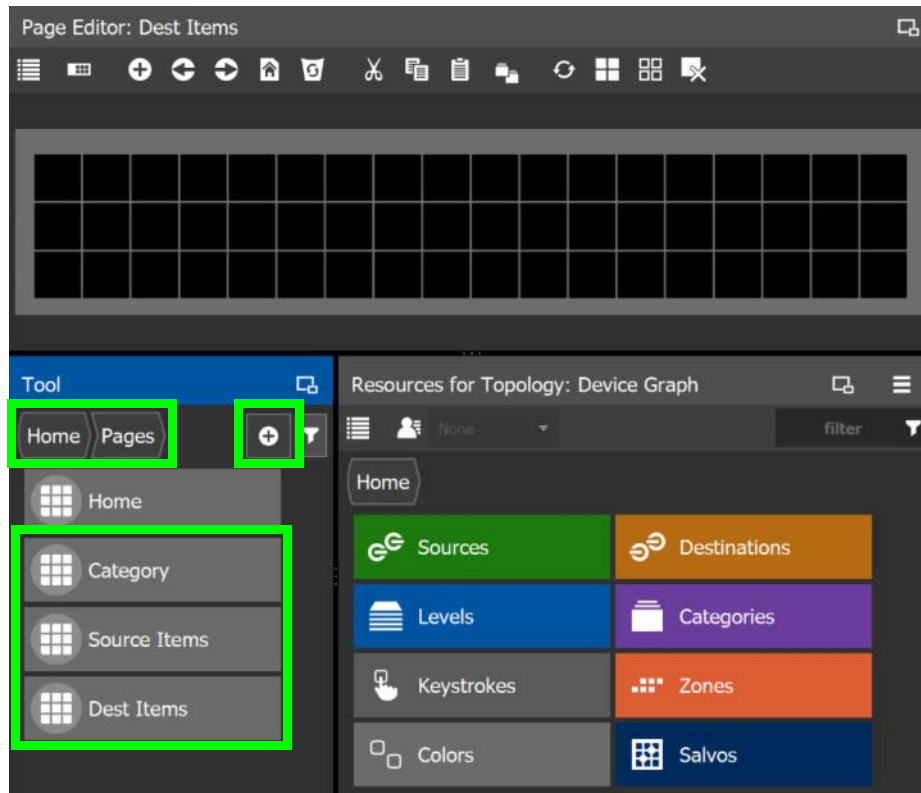

These are the pages between which the panel user will navigate according to the configuration parameters you set in the Panel's configuration, shown in later steps in this procedure.

- 7 On the **Home** page, add a **Load Page** from the **Built-In** Tool to a panel button. See [Adding Actions to a Panel](#), on page 114.

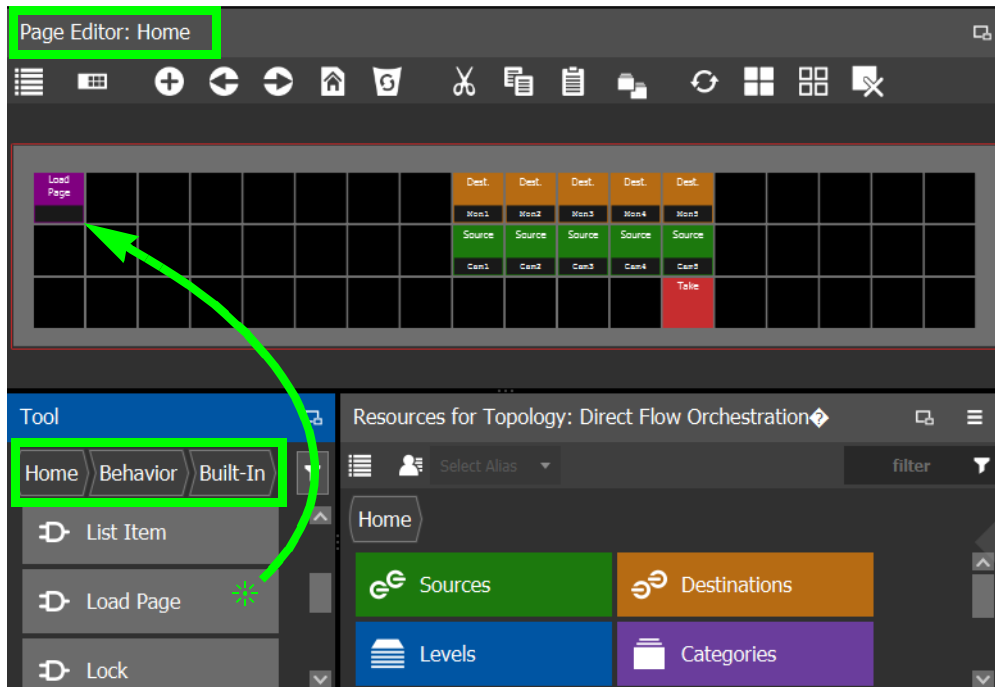

- 8 On the **Home** page, select the **Load Page** panel button and set the **Page** property parameter to **Category**. With this setting, when the panel user presses this button, they will be shown the **Category** page.

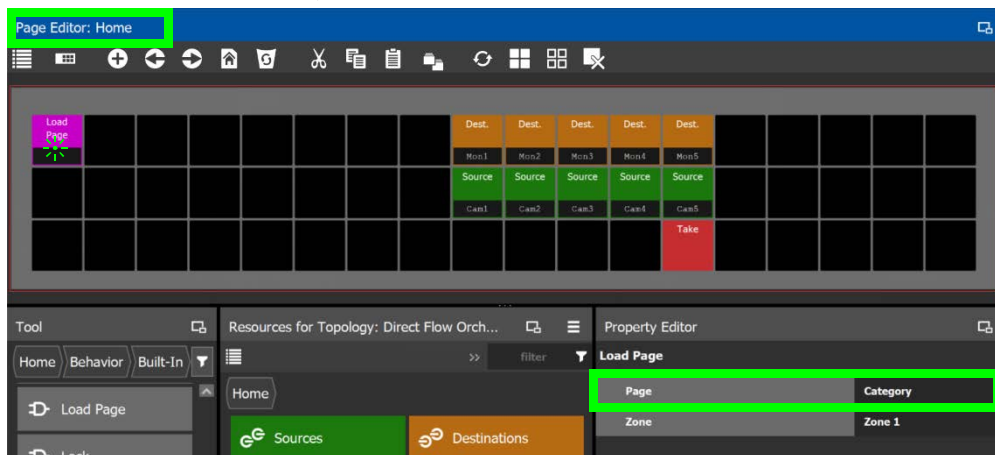

- 9 On the **Category** page, add the **Destination** Category to a panel button. See [Adding Resources to the Panel](#), on page 117.

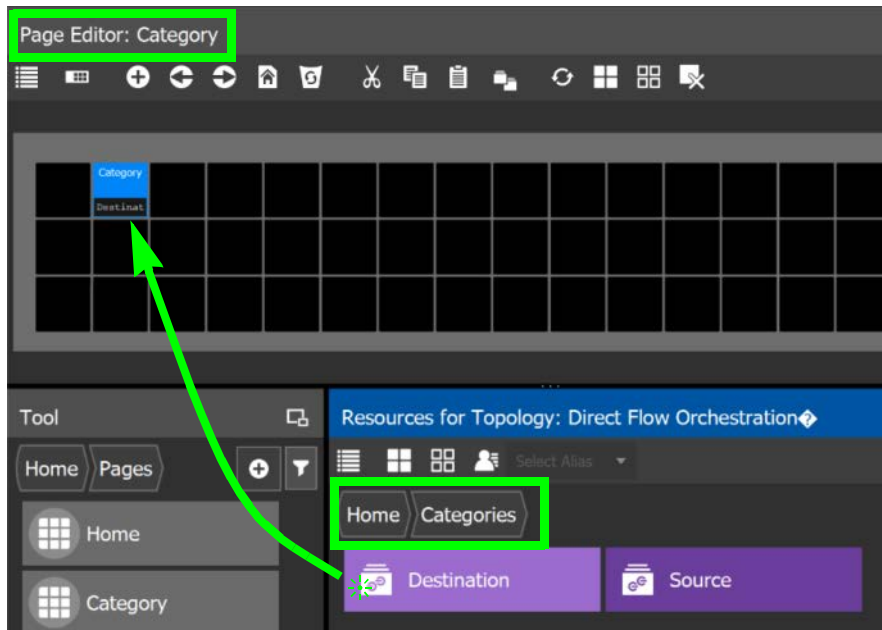

- 10 On the **Category** page, add the **Source** Category to a panel button. See [Adding Resources to the Panel](#), on page 117.

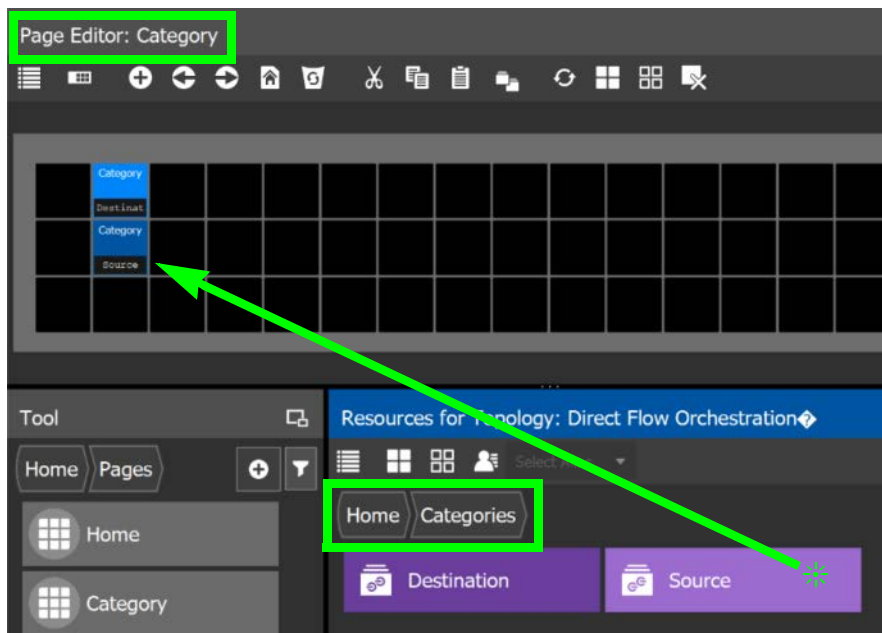

- 11 On the **Category** page, select the **Destination** Category panel button and set the **Exit Mode**, **Exit Page**, and **Page** property parameters.

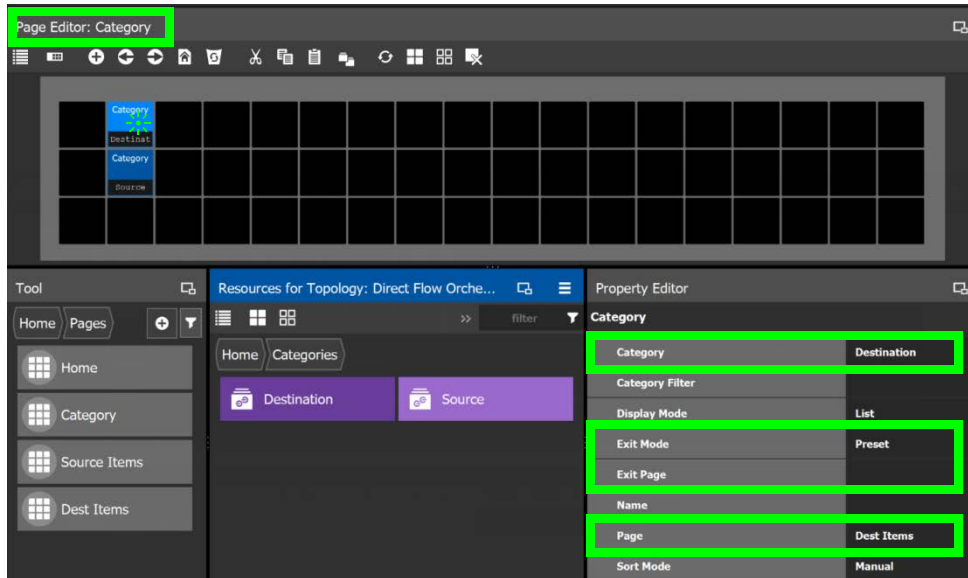

The following configuration parameter explanation should be interpreted within the context of this example procedure.

Parameter	Description
Category	This should show Destination for this step.
Exit Mode	Select how the panel user will be returned once they have made a category item selection or Take. In this example, set this to Preset . With this option, the panel behavior is to take the panel user to the Category page immediately once they have pressed a destination category in the Dest Items page.
Exit Page	In this example, this is set to [blank]. The Exit Page feature is unused.
Page	For the Destination category, set to Dest Items . With this setting, when the panel user presses this panel button on the Category page, they will be shown the Dest Items page where the panel user is able to select a destination item.

See also [Adding Resources to the Panel](#), on page 117 and [Setting the Properties for Panel Resources](#), on page 122 for more information about the remaining properties.

- 12 On the **Category** page, select the **Source** Category panel button and set the **Exit Mode**, **Exit Page**, and **Page** property parameters.

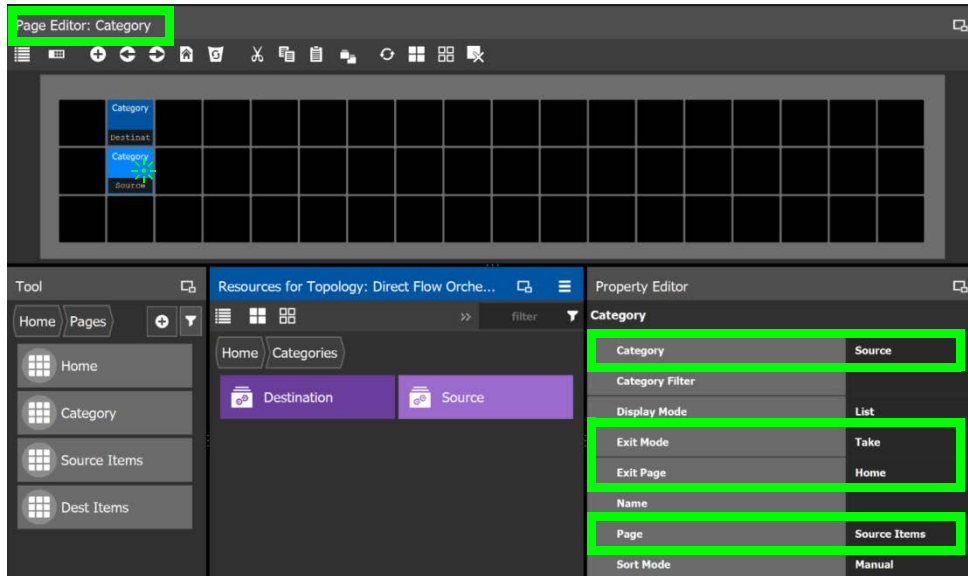

The following configuration parameter explanation should be interpreted within the context of this example procedure.

Parameter	Description
Category	This should show Source for this step.
Exit Mode	Select how the panel user will be returned once they have made a category item selection or Take. In this example, set this to Take . With this option, the panel user has to select a source category and then press the Take button.
Exit Page	In conjunction with the Exit Mode parameter, this parameter changes the Take return navigation to any other panel page. In this example, set this to Home ; the panel behavior is to take the panel user to the Home page immediately once they have pressed the category item selection and then the Take button in the Source Items page.
Page	For the Source category, set to Source Items . With this setting, when the panel user presses this panel button on the Category page, they will be shown the Source Items page where the panel user is then able to select a source item and then clicks Take.

- 13 On the **Dest Items** page, add five **List Item** from **Built-In** to five panel buttons. This corresponds to one **List Item** for each of the five sources.

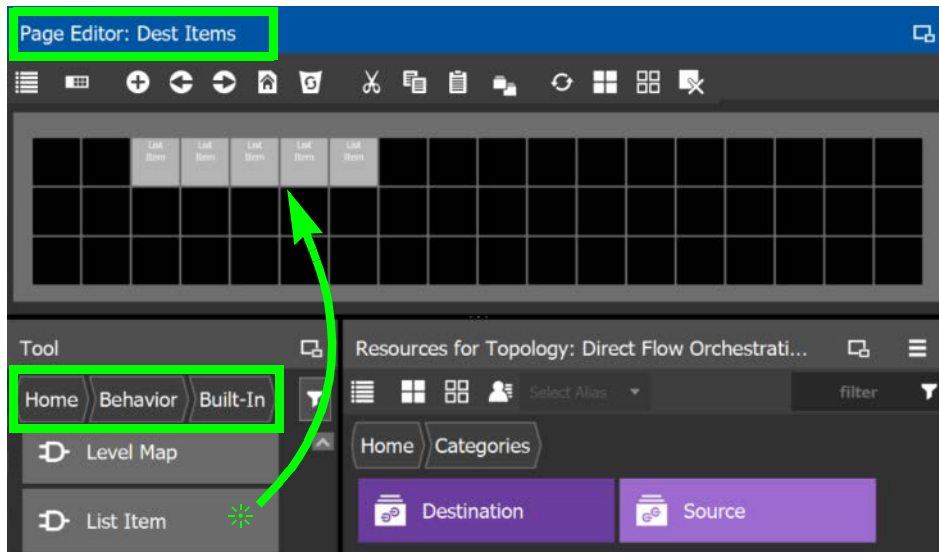

Note: You can use copy and paste a block of **List Item** on the panel to quickly create a large number of sources or destinations.

- 14 On the **Source Items** page, add five **List Item** from **Built-In** to five panel buttons. This corresponds to one **List Item** for each of the five sources. See [Adding Resources to the Panel](#), on page 117.

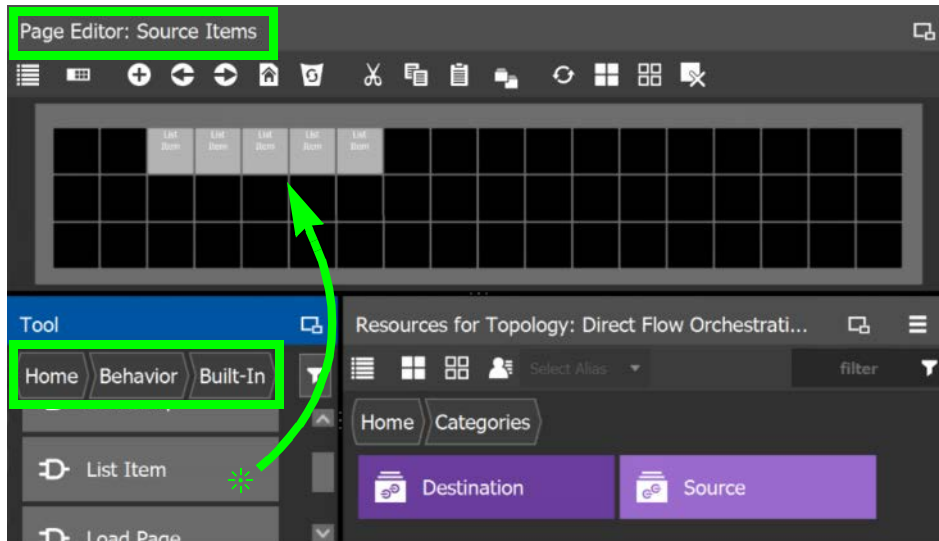

- 15 On the **Source Items** page, add a **Take** button.

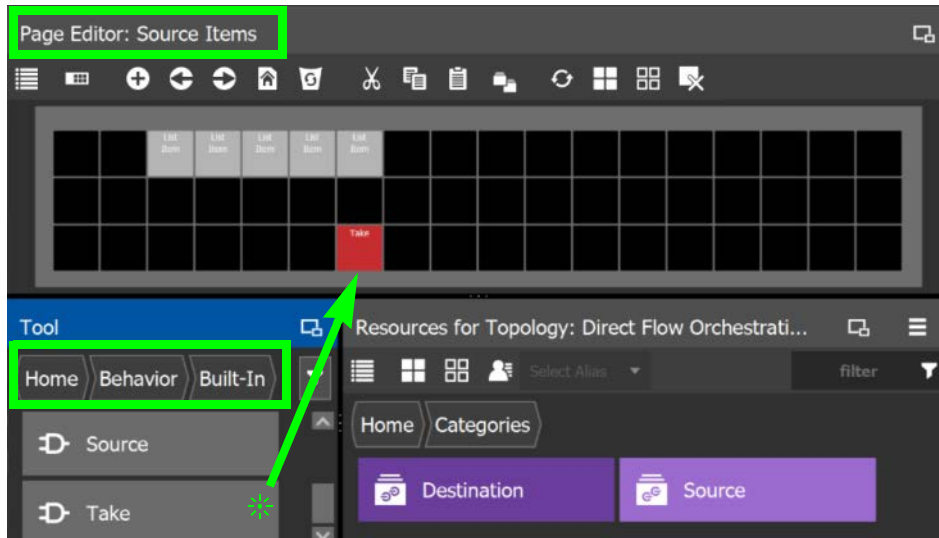

- 16 Add a panel device to the topology and configure the panel and its control port properties. See [Adding the New Panel to the Topology](#), on page 129.
Note: The panel device bubble on the Topology Configurator does not need to be linked to any other bubble.
- 17 In the Topology Configurator, activate the topology. See [Activating a Topology](#), on page 66.
- 18 Test the panel's behavior. Change the **Exit Page** and **Exit Mode** property parameters for the **Source** and **Destination** buttons on the **Category** page to see how the navigation behavior changes.
- 19 Add load page buttons that will allow the panel user to return to the Home page, to each of the following pages: **Category**, **Source Items**, and **Dest Items**. See also [Adding Resources to the Panel](#), on page 117 and [Setting the Properties for Panel Resources](#), on page 122 for more information.
This step is necessary because when the changing the **Exit Page** and **Exit Mode** property parameters for the **Source** and **Destination** buttons on the **Category** page, the panel user might wind up in a page without a way to exit out of it. Once testing is complete, and navigation is perfected, these buttons can be removed.

GPIO Configurator Tasks

Tally devices you connect to the panel's inputs can trigger events in the router control system such as a salvo or it can route a source to a destination.

In reaction to pressing a panel button, to a GPI input, or to a XPT status, the router control system can trigger events through the panel's relay outputs to switch your tally devices.

SUPPORTED PANELS: the following panels that support GPIO; NV9605, NV9606, NV9607, NV9609, NV9646, NV9649 (configured as a NV9609 panel model), NV9640, and NV9642.

Soft panels are available with GPIO controls that allow you to test and debug your GPIO configuration before putting a panel into production.

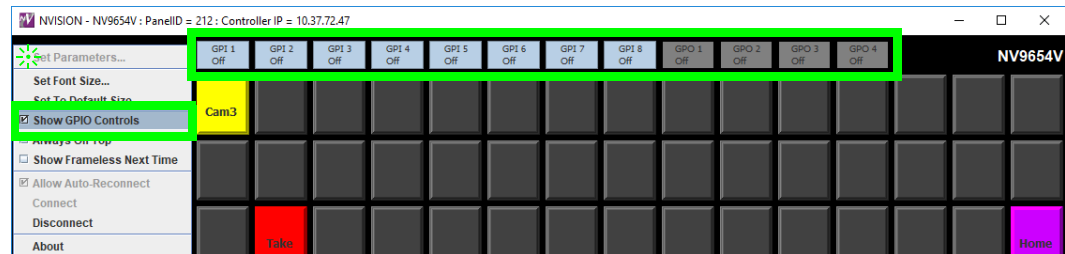

PREREQUISITES: The following must have been configured:

- a Topology ([Topology Configurator Tasks](#), on page 39) including:
 - Panel Configuration: see [Panel Configurator Tasks](#), on page 105
 - Sources and destinations: see [Methods to Link Devices in a Topology](#), on page 53.
- a router: see [Configuring Router Devices](#), on page 241

Accessing the GPIO Configurator

To access the GPIO Configurator Task

- 1 Open GV Orbit Control Stage. See [Navigating Back to Stage](#), on page 10.
- 2 Select an area. See [Selecting an Area](#), on page 23.
- 3 Select a topology. See [Selecting a Graph](#), on page 25.
- 4 Create and configure a Panel. See [Creating a New Panel](#), on page 107, [Configuring a Panel's Properties](#), on page 111, [Adding Actions to a Panel](#), on page 114, and [Adding Resources to the Panel](#), on page 117.
- 5 If a salvo is to be triggered by a GPI, create one or more salvos. See [Creating Salvos](#), on page 293.
- 6 If aliases are to be used, create them. See [Adding Aliases](#), on page 287.
- 7 Add a panel to the topology. See [Adding the New Panel to the Topology](#), on page 129.

8 Select **Configuration > GPIO Configurator**.

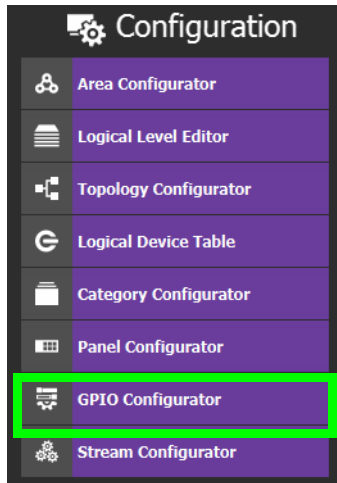

The GPIO Configurator task appears:

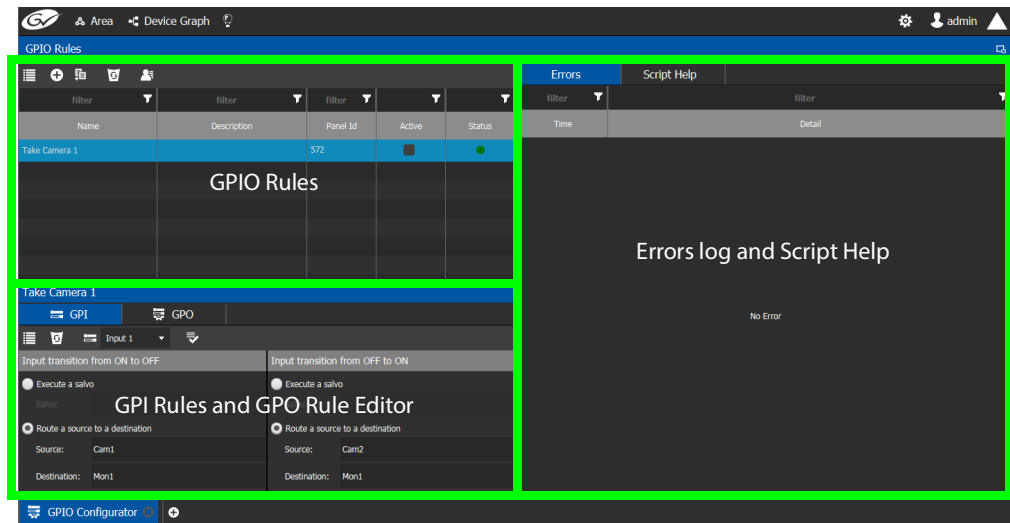





The GPIO Configurator has the following main sections shown above:

- GPIO Rules
- GPI Rules and GPO Rule Editor
- Errors log and Script Help

GPIO Rules Menu





The GPIO rules menu has the following menu options.

Icon	Description
 New	Create a new rule in the rules list. See Adding a GPIO Rule , on page 144.
 Duplicate	Make a copy of the currently-selected rule. See Duplicating a Rule , on page 150.

Icon	Description
 Delete	Remove the currently-selected rule. See Deleting a Rule , on page 151.
 Alias	Select the Alias to use for all rules. See Choosing an Alias for all Rules , on page 151.

GPI / GPO Rule Editor Menu

The GPIO rule editor has the following menu options.

Icon	Description
 Delete	Remove the configuration for this rule.
 Select GPI	Select the GPI input to be configured. See Configuring a GPI to Trigger an Event , on page 145.
 Select GPO	Select the GPO output to be configured. See Configuring a Script to Trigger a GPO , on page 147.
 Validate	Verifies if the rule is valid

Adding a GPIO Rule

Create one or more rules to control your tallies. Rules can be enabled and disabled as needed.

Note:

It is possible to create two or more rules can that act upon the same GPO, thereby creating a conflict. No error or warning will be flagged in this case. When two or more rules conflict, you must deactivate rule(s) such that only one rule controls a GPO at a time. See [Activating / Deactivating a Rule](#), on page 150.

To add a rule

- 1 Click **New** .

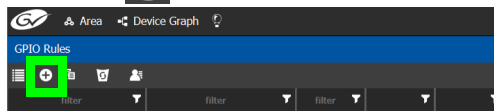

- 2 Enter meaningful text in the **Name** and **Description** fields to identify the rule.

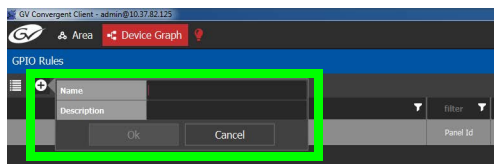

- 3 For the new row, click the cell for the Panel ID column.

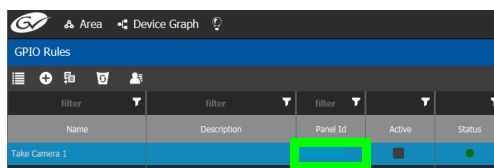

The **Panel Selector** window appears showing the panels that have been previously configured. See [Panel Configurator Tasks](#), on page 105.

- 4 Select the panel which has GPIO connections made to it that you want to configure.

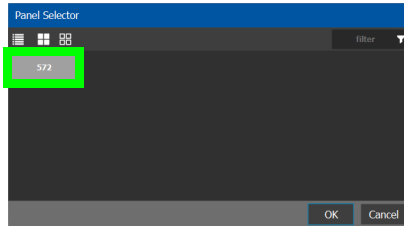

- 5 Click **OK**.

The Panel Id is shown for the GPIO rule and the Status is green.

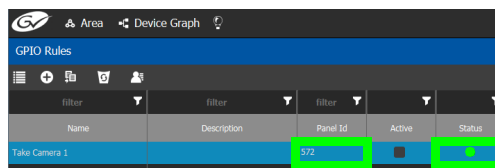

Configuring a GPI to Trigger an Event

Tally inputs (called GPIs) can be configured to trigger an event when the input transitions from OFF to ON and to trigger another event on a transition from ON to OFF. Events include:

- Execute a salvo. The salvo must have been previously created. See [Creating Salvos](#), on page 293.
- Route a source to a destination. The source and destination must have been previously created. See [Logical Device Table Tasks](#), on page 72.

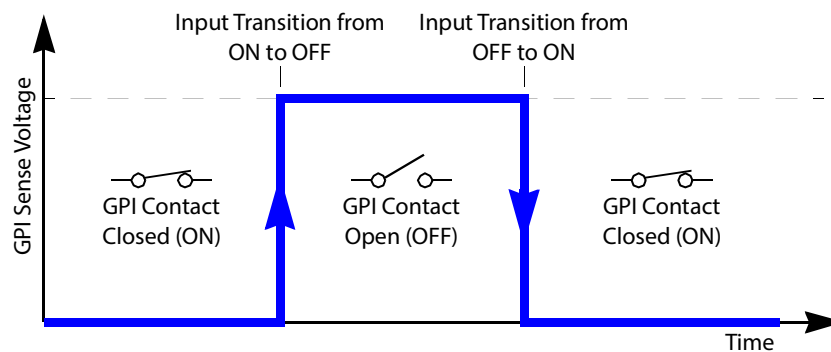

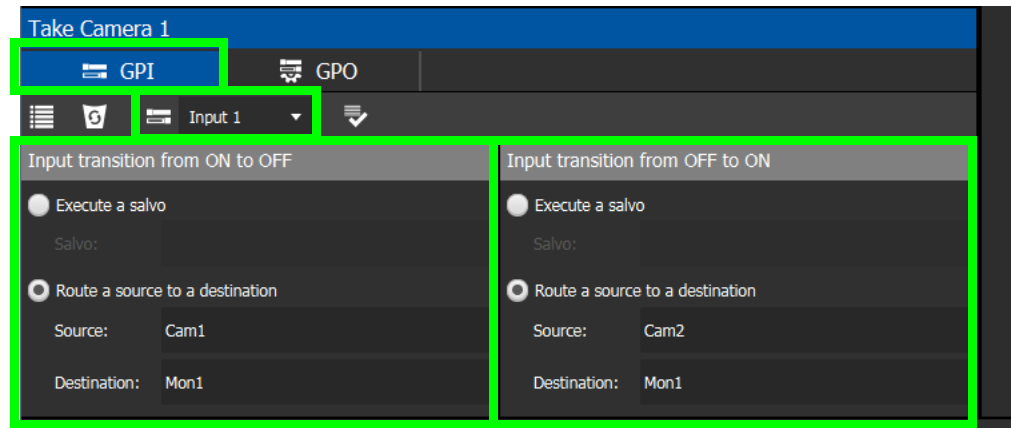

Separate actions are triggered depending on whether the transition is from ON to OFF or the transition is OFF to ON as shown above.

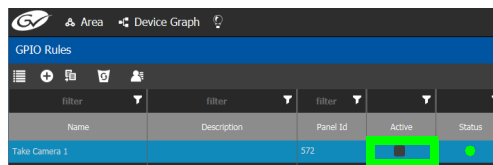

To configure a GPI state transition to route a source to a destination or trigger a salvo

- 1 Add a Rule if necessary. See [To add a rule](#), on page 144. Select the rule you want to configure. Ensure the rule is de-activated.



- 2 Click the GPI tab.
- 3 Select the panel's GPI input to be used as a trigger.
- 4 Select the action to execute when this input transitions from ON to OFF:
 - **Execute a salvo:** select the salvo to be executed from the list.
 - **Route a source to a destination:** select a source and a destination from the lists.
- 5 Select the action to execute when this input transitions from OFF to ON:
 - **Execute a salvo:** select the salvo to be executed from the list.
 - **Route a source to a destination:** select a source and a destination from the lists.
- 6 Repeat for the remaining GPI inputs to be used as a trigger for an action.
- 7 Click **Validate**  to check the syntax and semantics with respect to the current configuration and it then saves the script.
- 8 Activate the rule. See [To activate a rule](#), on page 150.

Configuring a Script to Trigger a GPO

Relay outputs can be configured to activate on a number of Boolean true or false conditions that form a script:

- One or more routes occurring on specific levels.
- Conditions involving output ports (destination, level).
- A transition on one or more of the panel's tally inputs.

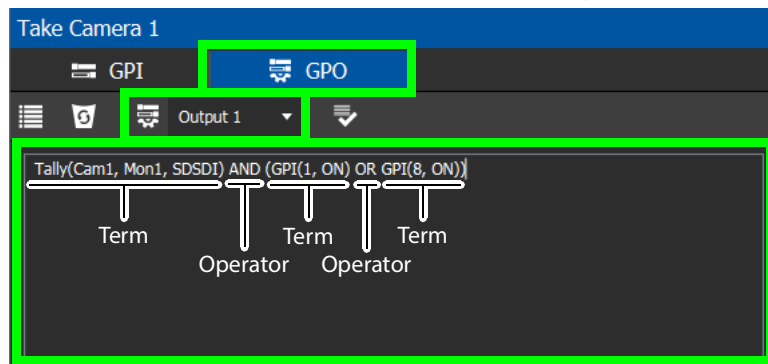

In this dialog, you create a Boolean script involving sources, destinations, port status, and GPI (input) status. When the conditions of the entire Boolean script evaluates as true, the relay output closes. When the conditions are not met, the relay output opens. Names of sources, destinations, levels and so on are case sensitive.

Boolean expressions comprise terms and operators. The operators include those shown under the **Script Help** tab. Expressions can be parenthesized to control the order of evaluation. Operator precedence is normally NOT > AND > OR. All parenthesized expressions are evaluated first; expressions in nested parentheses are evaluated before those in outer parentheses.

Function	Description
AND,OR, NOT,()	Logical AND, OR, NOT, and precedence. Note that && (AND), (OR), ! (NOT) are also supported.
Tally(SRC,DST)	Returns true when the specified source is tallied on the specified destination for the SDI level.
Tally(SRC,DST,Level)	Returns true when the specified source is tallied on the specified destination for the specified level.
Tally(SRC,DST,Levels...)	Returns true when the specified source is tallied on the specified destination for the specified level shuffles. Level shuffle arguments are in pairs.
Locked(DST)	Returns true when the specified destination is locked.
LockReleased(DST)	Returns true when the specified destination is unlocked.
Protected(DST)	Returns true when the specified destination is protected.
ProtectReleased(DST)	Returns true when the specified destination is unprotected.
GPI(GPI#, STATUS)	Returns true when the GPI status is equal to the specified STATUS. STATUS value could be ON or OFF.

For example, the following script is true when Cam1 is tallied on Mon1 for the SDSDI level and GPI1 input is on or GPI8 input is on:

`Tally(Cam1, Mon1, SDSDI) AND (GPI(1, ON) OR GPI(8, ON))`

Click a function to see an example script of how to use the function under **Example**.

Function	Description
AND, OR, NOT, ()	Logical AND, OR, NOT and precedence. Note that &&, , ! are also supported.
Tally(SRC, DST)	Returns true when the specified source is tallied on the specified destination for the SDI level.
Tally(SRC, DST, Level)	Returns true when the specified source is tallied on the specified destination for the specified level.
Tally(SRC, DST, Levels...)	Returns true when the specified source is tallied on the specified destination for the specified level shuffles. Level shuffle arguments are in pairs.
Locked(DST)	Returns true when the specified destination is locked.
LockReleased(DST)	Returns true when the specified destination is unlocked.
Protected(DST)	Returns true when the specified destination is protected.
ProtectReleased(DST)	Returns true when the specified destination is unprotected.
GPI(GPI#, STATUS)	Returns true when the GPI status is equal to the specified STATUS. STATUS value could be ON or OFF.

Examples

`Tally(Cam1, Mon1) AND (Tally(Cam1, Mon2) OR NOT(Tally(Cam2, Mon3)))`

To configure a script to control GPOs

- 1 Add a Rule if necessary. See [To add a rule](#), on page 144. Select the rule you want to configure. Ensure the rule is de-activated.

Name	Description	Panel Id	Active	Status
Take Camera 1		572	<input type="checkbox"/>	

- 2 Click the **GPO** tab.
- 3 Select the panel's GPO output to be used as a trigger.

Take Camera 1

GPI | **GPO**

Output 1

```
Tally(Cam1, Mon1, SDSDI) AND (GPI(1, ON) OR GPI(8, ON))
```

- 4 Create a script that when true will close the output relay's contact.

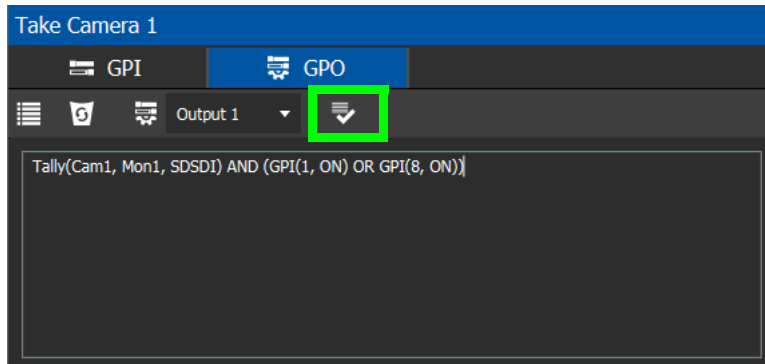

- 5 Click **Validate**  to check the script's syntax.

Any errors are shown in the **Errors** tab. Correct the script as necessary. Click the **Script Help** tab for how to use script arguments.

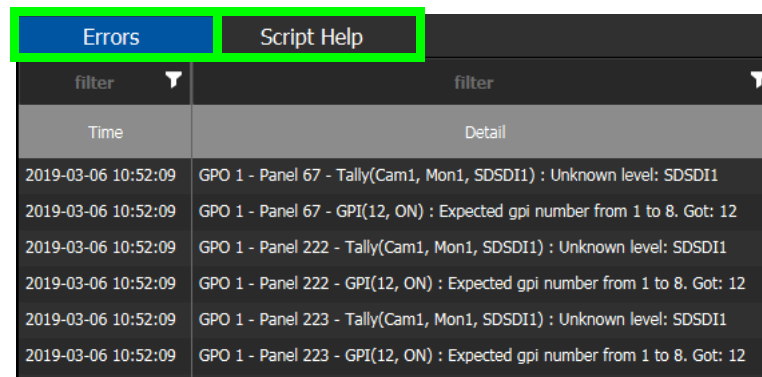

- 6 Activate the rule. See [To activate a rule](#), on page 150.

Deleting a GPI or GPO Action Configuration

To delete a GPI or GPO action configuration

- 1 Click the GPI or GPO tab.

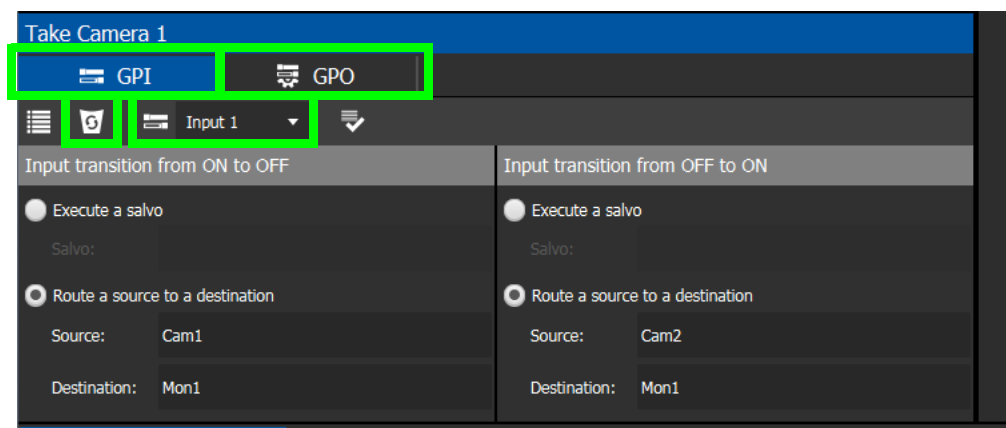

- 2 Select an **Input** or **Output** to be deleted.
- 3 Click **Delete** .

Activating / Deactivating a Rule

To activate a rule

- 1 Set **Active** in the rule's row.

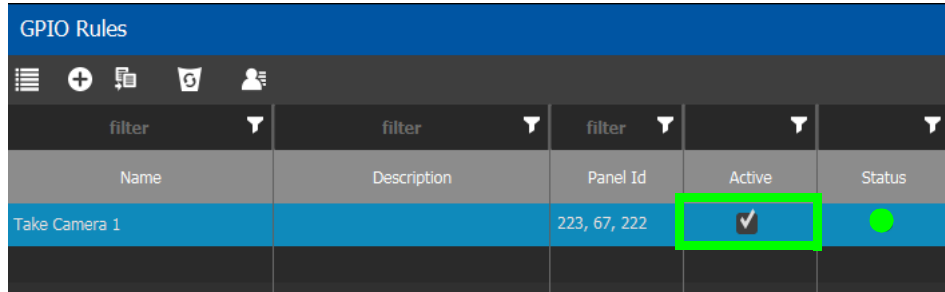

The screenshot shows a table titled "GPIO Rules" with the following columns: Name, Description, Panel Id, Active, and Status. The row for "Take Camera 1" is highlighted in blue, and the "Active" checkbox is checked and highlighted with a green box. The "Status" column shows a green circle.

Name	Description	Panel Id	Active	Status
Take Camera 1		223, 67, 222	<input checked="" type="checkbox"/>	●

The rule's configuration becomes read only and cannot be modified. The rule's status becomes a green circle to indicate that the rule is valid.

To deactivate a rule

- 1 Deselect **Active** in the rule's row.

Duplicating a Rule

To duplicate a rule

- 1 Select the rule to be duplicated.
- 2 Click **Duplicate** .

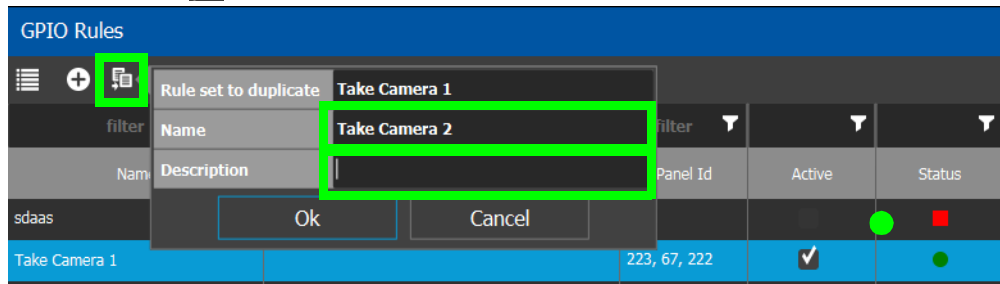

The screenshot shows the "GPIO Rules" table with the "Duplicate" button highlighted in green. A dialog box is open over the table, titled "Rule set to duplicate: Take Camera 1". The dialog has fields for "Name" (containing "Take Camera 2") and "Description" (empty). There are "Ok" and "Cancel" buttons at the bottom of the dialog. The table below the dialog shows the "Take Camera 1" row with its "Active" checkbox checked and "Status" as a green circle.

Name	Description	Panel Id	Active	Status
Take Camera 1		223, 67, 222	<input checked="" type="checkbox"/>	●

- 3 Set the name and description of the new rule.
- 4 Click **OK**.

Deleting a Rule

To delete a rule

- 1 Select the GPIO rule to be deleted.

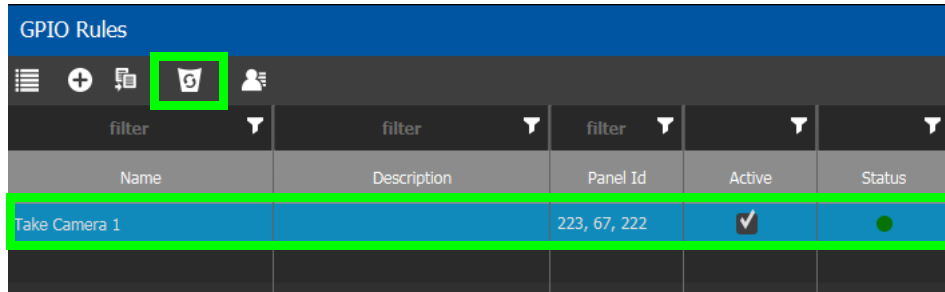

- 2 Click **Delete** .

Choosing an Alias for all Rules

The source and destination aliases must have been previously created. See [Adding Aliases](#), on page 287. The alias selection applies to all current rules.

To set an alias

- 1 Click **Alias** .

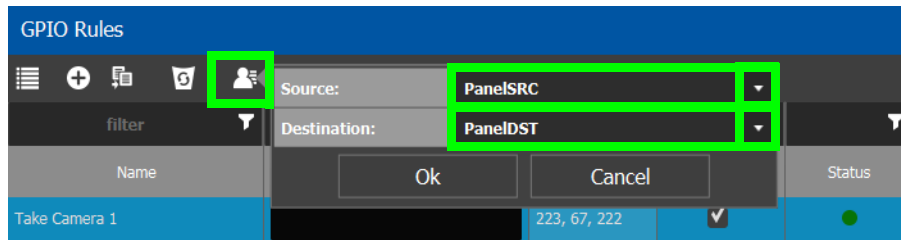

- 2 Set the **Source** and **Destination** aliases to use for all rules.
- 3 Click **OK**.

Stream Configurator Tasks

The Stream Configurator task displays all streams in the current topology and allows you to configure on a large scale the following stream parameters:

- Set the stream's Unicast and multicast IP addresses
- Change the stream's SDP template
- Change the stream's logical levels
- Expose or hide streams

This can be done in bulk by selecting multiple rows and using the paste functionality, to set the IP addresses of hundreds of streams in one action. Filters allow you to narrow down the list in order to only show the devices you want to change their IP addresses / port numbers. The list has multiple sort, so you can put the devices in the right order (from top to bottom), thereby allowing you to paste an incremental range of IP addresses. Content can be pasted from a vertical column of Microsoft Excel worksheet cells, or from a text editor where there is one IP address per line.

The Stream Configurator is also useful for troubleshooting: for example, you discover an unexpected IP address is being routed and you want to find the device associated with that IP address. Use the IP address in the filtering at the top of the **Unicast IP** or **Multicast IP** columns in the Stream Configurator to find the device.

PREREQUISITES: The following must have been configured:

- a Topology ([Topology Configurator Tasks](#), on page 39).
- a number of devices on the topology such as a GV Node which has a variety of streams (see [Adding Devices to a Topology](#), on page 44).

Setting the IP address in GV Orbit Control for third-party IP devices are an ideal application for the stream configurator; see [Using Quick Config](#), on page 50 and the example in [Setting Port Redundancy for Many Devices at Once](#), on page 51 to create such devices.

Accessing the Stream Configurator

To access the Stream Configurator Task

- 1 Open GV Orbit Control Stage. See [Navigating Back to Stage](#), on page 10.
- 2 Select an area. See [Selecting an Area](#), on page 23.
- 3 Select a topology. See [Selecting a Graph](#), on page 25.
- 4 The topology must be currently:
 - Activated (see [Activating a Topology](#), on page 66).
 - Unlocked (see [Unlocking / Relocking a Topology](#), on page 69).

5 Select **Configuration > Stream Configurator**.

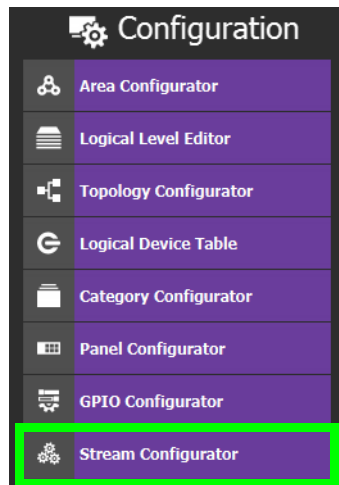

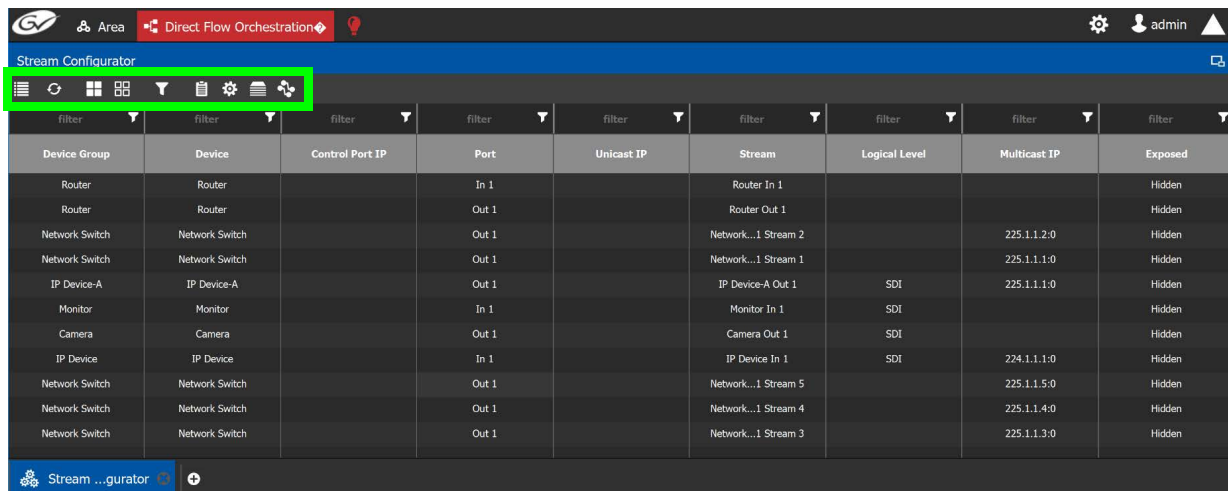

The Stream Configurator task appears:



Stream Configurator Menu

The Stream Configurator menu has the following menu options.

Icon	Description
Refresh	Reloads the Stream Configurator's contents. The Stream Configurator's content is static. If you make a configuration change in another task, it will not automatically be reflected in the Stream Configurator.
Select All	Selects all rows in the Stream Configurator.
Clear All	Deselects all rows in the Stream Configurator.
Filters	Filters the list by signal type and direction. See Stream Configurator Filters Tool , on page 155.

Icon	Description																																				
 Paste IP addresses	<p>Pastes the clipboard contents to the selected Stream Configurator's column from a Microsoft Excel spreadsheet column or a text editor, where there is one IP address per line.</p> <p>See Pasting Unicast and Multicast IP Addresses from a Microsoft Excel Spreadsheet / Text Editor, on page 156.</p> <p>Certain IP addresses are reserved by GV Orbit Control and cannot be used. Refer to the Release Notes for more information. See Related Documentation, on page 7.</p>																																				
 Set stream SDP file	<p>Set the SDP pattern for streams. See Setting SDP Templates for one or more Streams, on page 157.</p>																																				
 Set stream level	<p>Sets the logical level of one or more selected streams. This shows the Logical Level Selector.</p> <div data-bbox="646 741 1166 1056" style="border: 1px solid black; padding: 5px; margin: 10px 0;"> <p>Logical Level Selector - audio1</p> <table border="1" style="width: 100%; border-collapse: collapse; text-align: center;"> <thead> <tr> <th colspan="2">audio2</th> <th colspan="2">audio3</th> <th colspan="2">audio4</th> </tr> <tr> <th>Level ID 5</th> <th>A2</th> <th>Level ID 6</th> <th>A3</th> <th>Level ID 7</th> <th>A4</th> </tr> </thead> <tbody> <tr> <td>Level ID 8</td> <td>audio5 A5</td> <td>Level ID 9</td> <td>audio6 A6</td> <td>Level ID 10</td> <td>audio7 A7</td> </tr> <tr> <td>Level ID 11</td> <td>audio8 A8</td> <td>Level ID 12</td> <td>audio9 A9</td> <td>Level ID 13</td> <td>audio10 A10</td> </tr> <tr> <td>Level ID 14</td> <td>audio11 A11</td> <td>Level ID 15</td> <td>audio12 A12</td> <td>Level ID 16</td> <td>audio13 A13</td> </tr> <tr> <td>Level ID 17</td> <td>audio14 A14</td> <td>Level ID 18</td> <td>audio15 A15</td> <td>Level ID 19</td> <td>audio16 A16</td> </tr> </tbody> </table> <p style="text-align: right;">OK Cancel</p> </div> <p>Select a logical level and click OK to change the level of all selected streams to the new logical level.</p> <p>For more information about logical levels, see Logical Level Editor Tasks, on page 30.</p>	audio2		audio3		audio4		Level ID 5	A2	Level ID 6	A3	Level ID 7	A4	Level ID 8	audio5 A5	Level ID 9	audio6 A6	Level ID 10	audio7 A7	Level ID 11	audio8 A8	Level ID 12	audio9 A9	Level ID 13	audio10 A10	Level ID 14	audio11 A11	Level ID 15	audio12 A12	Level ID 16	audio13 A13	Level ID 17	audio14 A14	Level ID 18	audio15 A15	Level ID 19	audio16 A16
audio2		audio3		audio4																																	
Level ID 5	A2	Level ID 6	A3	Level ID 7	A4																																
Level ID 8	audio5 A5	Level ID 9	audio6 A6	Level ID 10	audio7 A7																																
Level ID 11	audio8 A8	Level ID 12	audio9 A9	Level ID 13	audio10 A10																																
Level ID 14	audio11 A11	Level ID 15	audio12 A12	Level ID 16	audio13 A13																																
Level ID 17	audio14 A14	Level ID 18	audio15 A15	Level ID 19	audio16 A16																																
 Expose or hide streams	<p>Sets to expose or hide streams of one or more selected streams. Only certain devices support this property. When Expose Stream is set, it displays the streams for this device in the Logical Device Table. See Logical Device Table Tasks, on page 72.</p>																																				
 Filter	<p>Row filters can be applied to each column by typing text in the filter boxes to filter the list according to a column's content. The combination of all applied filters means that a row must match all filter values in order to be displayed. See Filtering the Stream Configurator List, on page 155. See also Filtering Lists, Table Columns, Sources, and Destinations, on page 97.</p>																																				

Stream Configurator Filters Tool

A filter button is available in the toolbar for you to show or hide signal types (SDI, IP, MADI) or signal direction (Input/Rx and Output/Tx streams).

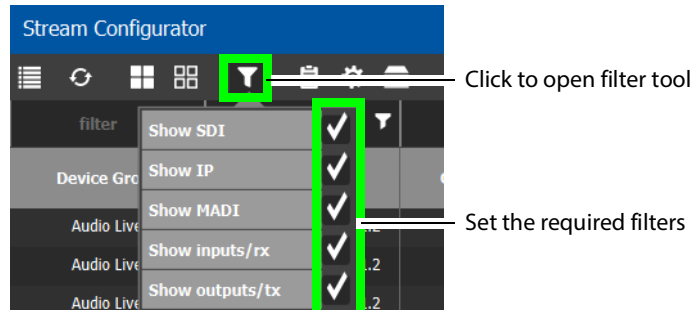

Icon	Description
Show SDI	Show results where the connection type is SDI.
Show IP	Show results where the connection type is IP.
Show MADI	Show results where the connection type is MADI.
Show inputs / rx	Show results where the connection direction is an input.
Show outputs / tx	Show results where the connection direction is an output.

Pasting IP addresses from a Microsoft Excel worksheet into the Stream Configurator

In order to paste a vertical column of worksheet cells of an ordered list of IP addresses you have created in Microsoft Excel, you must first prepare the Stream Configurator by:

- 1 Filtering the table to only show the devices, inputs / outputs, signal type, logical levels, for which you are going to update their IP addresses. Filters allow you to narrow down the Stream Configurator list in order to only show the devices of interest.
- 2 Sorting the filtered list such that the devices are in the same order as the vertical column of worksheet cells you have created in Microsoft Excel.
- 3 Paste a vertical column of worksheet cells you have created in Microsoft Excel into either the Unicast IP or Multicast IP columns of the Stream Configurator.

Certain IP addresses are reserved by GV Orbit Control and cannot be used. Refer to the Release Notes for more information. See [Related Documentation](#), on page 7.

Filtering the Stream Configurator List

First, filter the Stream Configurator's contents to create a list of only the devices that are of interest; those devices you want to update their IP addresses.

Filtering can be done by combining the following methods:

- Use the Filters tool to show or hide signal types (SDI, IP, MADI) or signal direction (Input/Rx and Output/Tx streams). See [Stream Configurator Filters Tool](#), on page 155.
- Enter text into the row filters found at the top of each column by typing text in the filter boxes to filter the list according to a column's content. The combination of all applied filters means that a row must match all filter values in order to be displayed. See [Filtering Lists, Table Columns, Sources, and Destinations](#), on page 97.

filter	filter	filter	filter	filter	filter	filter	filter
Device Group ▲	Device ▲	Control Port IP ▲	Port ▲4	Unicast IP ▲5	Stream ▲6	Logical Level ▲7	Multicast IP ▲8
Audio Live	Audio Live 191.13.11.2		Eth In 1	191.13.11.2	Audio Live...1 Stream 1	AES67-64	236.1.1.1:0
Audio Live	Audio Live 191.13.11.2		Eth In 1	191.13.11.2	Audio Live...1 Stream 2	AES67-64	225.2.1.1:0

Sorting the Stream Configurator List

Once the Stream Configurator's contents have been filtered, then sort the filtered list.

The list has multiple sort, so you can put the devices in the right order (from top to bottom), thereby allowing you to paste an incremental range of IP addresses. Content can be pasted from a vertical column of Microsoft Excel worksheet cells, or from a text editor where there is one IP address per line.

Each column can be sorted by clicking the header text. Multiple sort can be applied by <Shift> + clicking the headers. Bullets and numbers will appear next to the sort arrow indicating the column's sort priority. An up arrow is ascending sort, and a down arrow is a descending sort.

filter	filter	filter	filter	filter	filter	filter	filter
Device Group ▲	Device ▲	Control Port IP ▲	Port ▲4	Unicast IP ▲5	Stream ▲6	Logical Level ▲7	Multicast IP ▲8
Audio Live	Audio Live 191.13.11.2		Eth In 1	191.13.11.2	Audio Live...1 Stream 1	AES67-64	236.1.1.1:0
Audio Live	Audio Live 191.13.11.2		Eth In 1	191.13.11.2	Audio Live...1 Stream 2	AES67-64	225.2.1.1:0

First sort priority (one bullet)
 Second sort priority (two bullets)
 Third sort priority (three bullets)
 Fourth sort priority
 Fifth sort priority
 . . .
 Eighth sort priority

Pasting Unicast and Multicast IP Addresses from a Microsoft Excel Spreadsheet / Text Editor

Unicast and Multicast IP address values can be bulk pasted into the Stream Configurator from a Microsoft Excel spreadsheet column by using copy/paste.

- Multicast IPs are formed with the following semi-colon separated concatenated format: **[IPv4 Address]:[Port Number]**. For example, the text to be pasted for a multicast address should look like **231.102.30.13:5004**
 If you paste an IPv4 address without a port number into the **Multicast IP** column, only the IP address will be updated and the current port number will be left intact.
- Unicast IPs are a basic IP address without a port number.

To paste Unicast or Multicast IP Addresses

- 1 Select a column with IP addresses from a Microsoft Excel spreadsheet and copy them.
- 2 Select the rows in the Stream Configurator that contain the streams to be changed. See [Selecting Stream Configurator Rows](#), on page 159.

- 3 Click the paste  button in the Stream Configurator toolbar. Choose whether to apply the paste to Unicast or Multicast IP addresses. The paste is made starting from top-to-bottom of the selected rows.

Note: All pasted IP addresses are validated and if any one address is invalid, the entire paste is canceled and nothing happens.
Certain IP addresses are reserved by GV Orbit Control and cannot be used. Refer to the Release Notes for more information. See [Related Documentation](#), on page 19.

Editing Unicast and Multicast IP Addresses

Cells in the Unicast IP column can be double-clicked in order to edit their contents. These cells will only accept valid IPv4 addresses.

Cells in the Multicast IP column can also be double-clicked in order to edit their contents. These cells only accept valid IPv4 addresses and a port number separated by a colon (:). For example **231.102.30.13:1080**.

Setting SDP Templates for one or more Streams

Not all devices are NMOS compliant, however with the use of SDP parameters, GV Orbit Control may be able to make a take of a stream from a non-NMOS Device to an NMOS Device. GV Orbit Control can intuit some SDP parameters while other parameters will have to be provided by you. For more information about how to form an SDP template, see [Using SDP Parameters to Take a Stream from a non-NMOS Device to an NMOS Device](#), on page 216.

You can set the SDP templates for one or more streams as follows.

- 1 If necessary, filter and sort the Stream Configurator list to only show the devices, inputs / outputs, signal type, logical levels, for which you are going to update their SDP templates. Filters allow you to narrow down the Stream Configurator list in order to only show the devices of interest. See [Filtering the Stream Configurator List](#), on page 155 and [Sorting the Stream Configurator List](#), on page 156.
- 2 Select the rows in the Stream Configurator that contain the streams to be changed. See [Selecting Stream Configurator Rows](#), on page 159.
- 3 Click the cogwheel  icon. The SDP template text for the last selected stream in the table is shown in a pop-up.
If the last selected stream type is SDI or a receiver, the SDP template text area will be blank.
- 4 Type in or paste the SDP template text into the pop-up text area and click **OK**. See [Using SDP Parameters to Take a Stream from a non-NMOS Device to an NMOS Device](#), on page 216.

Note: The SDP text you enter is not validated by GV Orbit Control. The SDP is directly applied to IP streams only. All other stream types are ignored.

All selected streams will be updated with the new SDP template.

GV Orbit Control SDP Variables that can be used with Third-Party Devices

The following table lists whether the GV Orbit Control SDP variables are supported when used with third-party devices. Any unsupported SDP variable must be replaced by a hard coded value that represents the third-party device's static property value.

GV Orbit Control SDP Variable	Supported with third-party-devices	Description
<code>\${audioBits}</code>		The audio stream's bit depth.
<code>\${channelCount}</code>		The number of (audio) channels.
<code>\${clockSetting}</code>		The PTP master clock setting.
<code>\${sequence}</code>		This SDP file's ID.
<code>\${packetTime}</code>		The length of time in milliseconds represented by the (audio) media in a packet.
<code>\${portIpAddress}</code>	•	The sending port's IP address. The source for this variable comes from the Port's IP Address parameter for this stream.
<code>\${streamIpAddress}</code>	•	The transmit (sending) stream's multicast IP address. The source for this variable comes from the stream's IP Address parameter.
<code>\${streamPortNumber}</code>	•	The transmit (sending) stream's IP port number. The source for this variable comes from the stream's IP Port parameter.
<code>\${redundantIpAddress}</code>	•	The transmit (sending) stream's redundant multicast IP address. The source for this variable comes from the stream's IP Address parameter used for the redundancy port. See the Redundancy Port parameter to identify the current redundancy port.
<code>\${redundantPortNumber}</code>	•	The transmit (sending) stream's redundant IP port number. The source for this variable comes from the stream's IP Port parameter used for the redundancy port. See the Redundancy Port parameter to identify the current redundancy port.

GV Orbit Control SDP Variable	Supported with third-party-devices	Description
<code>\${redundantPortIpAddress}</code>	•	The transmit (sending) stream's redundant IP port number. The source for this variable comes from the stream's IP Address parameter used for the redundancy port. See the Redundancy Port parameter to identify the current redundancy port.
<code>\${rtpPayloadType}</code>		The RTP payload type as defined by the SDP specification.
<code>\${samplingRate}</code>		The audio stream's sampling rate.

Selecting Stream Configurator Rows

Stream Configurator rows can be selected as follows:

- All current rows can be selected by clicking **Select All** from the Stream Configurator's menu. See [Stream Configurator Menu](#), on page 153.
- Select one or more streams in the Stream Browser using <Ctrl> + click.
- Select a range of streams in the Stream Browser by selecting the first stream and then <Shift> + click the last stream in the range.

4 Special Device Configuration Tasks

The configuration of certain features for a specific device require an in depth explanation which is provided here.

Special Devices

These special device are described under the following headings:

- [Configuring a GV Node Device](#), on page 163
- [Configuring an IPG-3901 / IPG-4901 Device](#), on page 174
- [Configuring an IPVU Device](#), on page 180
- [Configuring an IQMix, IQUCP, or UCP-3901 Device](#), on page 183
- [Configuring UHD 4K Two-Sample Interleave Division IP Streams for use with an IQMix, IQUCP, UCP-3901, or IPVU Device](#), on page 185
- [Configuring UHD 4K Quad-Link SDI Streams for use with an IQMix, IQUCP, UCP-3901, or IPVU Device](#), on page 190
- [Configuring an MV-820-IP Multiviewer Device](#), on page 194
- [Configuring a Kahuna IP Production Switcher Device](#), on page 198
- [Configuring a K-Frame Production Switcher](#), on page 201
- [Adding NMOS Devices to a Topology](#), on page 208
- [Using SDP Parameters to Take a Stream from a non-NMOS Device to an NMOS Device](#), on page 216
- [Configuring Cisco DCNM Network Switch Devices](#), on page 220
- [Direct Flow Orchestration: How To Create a Static Flow with a Cisco Network Switch](#), on page 226
- [Configuring Network Switch Redundancy to Support SMPTE ST 2022-7](#), on page 230
- [Configuring an NVISION Hybrid Series Router](#), on page 235
- [Configuring Router Devices](#), on page 241
- [Configuring a Device that Supports Audio Breakaway/Shuffling such as Audio Live](#), on page 252
- [Configuring an IQAMD40 Device](#), on page 265

Description of Common Device Properties

The description for certain device properties are universal.

Parameter	Description
# Input Connectors	The number of physical input port connections made to the device. This shows the current status for information purposes.
# Output Connectors	The number of physical output port connections made to the device. This shows the current status for information purposes.
# Streams Per Input	The typical number of streams available on each physical input connection. This shows the current status for information purposes.
# Streams Per Output	The typical number of streams available on each physical output connection. This shows the current status for information purposes.
# Streams	The actual number of streams available on the selected physical input / output connection. This shows the current status for information purposes.
Automatic Destination Automatic Destinations on Inputs Automatic Destinations on Outputs	Set to automatically create a destination by the system for the specified streams. See also About Automatic Sources or Destinations , on page 76.
Automatic Source Automatic Sources on Outputs Automatic Sources on Inputs	Set to automatically create a source by the system for the specified streams. See also About Automatic Sources or Destinations , on page 76.
Description	An optional description for the related input, output, or device.
Enabled	This shows the current status for information purposes.
Expose Streams	When set, it displays the streams for this device in the Logical Device Table. See Logical Device Table Tasks , on page 72. Quick Config can be used to set or clear this parameter; see Using Quick Config , on page 50.
Logical Level	The logical level for this input or output. See Logical Level Editor Tasks , on page 30.
Name	The name or identifier for this device instance. The name or identifier for this input or output port.
Short Name	The nickname by which the input, output, or device is referred to everywhere in the system.
SSM Address Enabled	Shows if the source specific multicast address is enabled.
SDP	See Using SDP Parameters to Take a Stream from a non-NMOS Device to an NMOS Device , on page 216.

Configuring a GV Node Device

To configure a GV node Device

- 1 Add the **GV Node** device to the Topology: from the **Device Library, Virtual Device**, find the **GV Node** device bubble. See [To add a Virtual Device to a topology](#), on page 44.

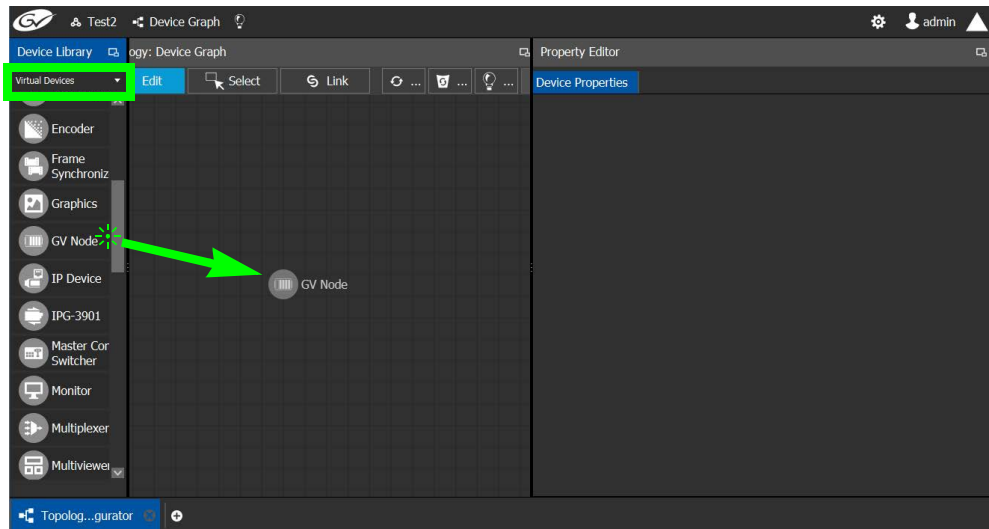

- 2 Select the **GV Node** bubble and configure the Device Properties in the **Property Editor**. See [Defining Device Properties](#), on page 61 for more information.

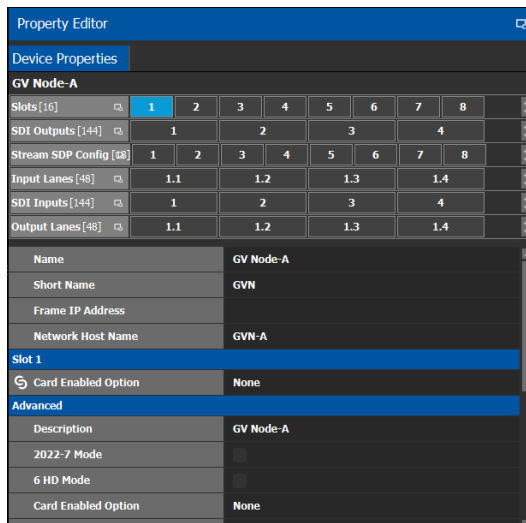

See also [Description of Common Device Properties](#), on page 162.

Parameter	Description
Frame IP Address	The network IP address for the associated GV Node frame.
Network Host Name	The hostname is the unique name by which the associated GV Node CPU-ETH3 is known on the network.
Advanced > Description	An optional description for this GV Node's control port.

Parameter	Description
Advanced > 2022-7 Mode	When the IFM-2T-OPT-40G-6 option is active, you can choose to enable SMPTE ST 2022-7 Low Latency redundant, high-bit-rate streams on the aggregation ports, using the GV Node manager. If this option has been enabled in the GV Node Manager, then enable it here.
Advanced > 6 HD Mode	This no redundancy, low bitrate option reduces each channel from 3Gbps to 1.5Gbps, allowing all 144 channels to be sent on aggregation ports 1-6, and leaving aggregation ports 7-12 unused. If this option has been enabled in the GV Node Manager, then enable it here.
Advanced > Card Enabled Option	This option controls audio embedding / de-embedding. For example, the XIO-4901 3G/HD/SD SDI input/output card supports audio embedding/de-embedding, as a software option (MDX): MDX: The GV Node Manager allows you to enable or disable audio embedding/de-embedding on a card's SDI inputs and outputs. None: If your system is monitoring MADI signals (supported at the XIO-4901 card's inputs/outputs 8 and 9), then disabling the MDX option lets you select MADI at the inputs and outputs matching your physical configuration. See Configuring MADI support with a GV Node Device , on page 169 for more information.
Advanced > Card Mode	Set the signal type.
Advanced > Gateway Connection State 1	Gateway Connection State 1 shows the connection status of the GV Node frame with the primary server of a server group.
Advanced > Gateway Connection State 2	Gateway Connection State 2 shows the connection status of the GV Node frame with the secondary server of a server group. See Configuring a Controller Group , on page 19. unknown: The topology is inactive (see Activating a Topology , on page 66) or the GV Node frame does not have network connectivity to the GV Orbit Server(s). offline: The GV Node frame does not have network connectivity to the GV Orbit Server(s). online: The GV Node frame is connected to the GV Orbit Server(s).
Advanced > Gateway NP16 Connection State	This shows the NP16 connection status of the GV Node frame with a server of a server group. unknown: The topology is inactive (see Activating a Topology , on page 66) or the GV Node frame does not have network connectivity to the GV Orbit Server(s). offline: The GV Node frame does not have network connectivity to the GV Orbit Server(s). online: The GV Node frame is connected to the GV Orbit Server(s).
Advanced > IFM-2T Version	The IFM-2T Fabric Module User Interface version number.
Advanced > Internal Wiring Done	Shows if the internal modeling of the GV Node is complete.

Parameter	Description
Advanced > Join Timeout (ms)	When GV Orbit Control is used with a GV Node version 1.3.0, to allow a clean switch that will not be reported as a fail, we recommend this parameter to be set to 2 ms.
Advanced > Router Connection State 1	Router Connection State 1 shows the connection status of the router with the primary server of a server group.
Advanced > Router Connection State 2	Router Connection State 2 shows the connection status of the router with the secondary server of a server group. See Configuring a Controller Group , on page 19. unknown: The topology is inactive (see Activating a Topology , on page 66) or the router does not have network connectivity to the GV Orbit Server(s). offline: The router does not have network connectivity to the GV Orbit Server(s). online: The router is connected to the GV Orbit Server(s).

3 Configure the card in each slot and configure the inputs and outputs for each card by making a selection at the top to make the related parameters become available below.

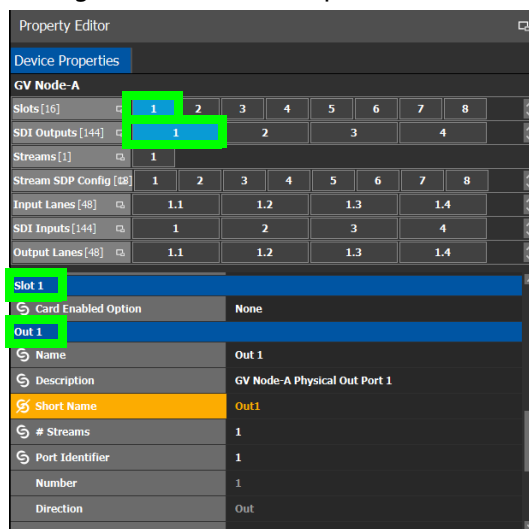

Select the	To configure the properties exposed below under
Card by its slot number in Slots	Slot #
Card's SDI output number in SDI Outputs . Then select the Card's SDI Output Stream Configuration number in Streams	Out # GV Node-[instance] Out #
Card's Stream SDP Configuration number in Stream SDP Config	IP Stream Prototype #
Card's Input Lanes number in Input Lanes . Then select the card's stream number in Streams .	Eth In #.# GV Node-[instance] Eth In#.# Stream #

Select the	To configure the properties exposed below under
Card's SDI Input number in SDI Inputs . Then select the card's stream number in Streams .	In# GV Node-[instance] In#
Card's Output Lanes number in Output Lanes . Then select the card's stream number in Streams .	Eth Out #.# GV Node-[instance] Out#.# Stream #

Configure the GV Node Card Properties in the **Property Editor**. See also [Description of Common Device Properties](#), on page 162.

Parameter	Description
Slot #	
Card Enabled Option	This option controls audio embedding / de-embedding. For example, the XIO-4901 3G/HD/SD SDI input/output card supports audio embedding/de-embedding, as a software option (MDX): MDX: The GV Node Manager allows you to enable or disable audio embedding/de-embedding on a card's SDI inputs and outputs. None: If your system is monitoring MADI signals (supported at the card's inputs/outputs 8 and 9), then disabling the MDX option lets you select MADI at the inputs and outputs matching your physical configuration. See Configuring MADI support with a GV Node Device , on page 169 for more information.
Out #	
Name	The name or identifier for this SDI output.
# Streams	The number of streams for this SDI output.
Port Identifier	An input lane is specified as QSPFport.lane which in turn corresponds to a physical port on the router. The number property specifies which physical port it is. The port identifier is how you name it so that you can refer to it.
Number	Set the port number on the router.
Direction	This shows the current status for information purposes.
Connector Type	
Capacity (bps)	The stream's data rate.
IP Address	The stream's network IP address.
Mods-Out to IFM	This option sets the expected output signal type: SDI: The output signal is a standard SDI video signal with embedded audio. MADI: The output signal is a MADI signal (supports 64 audio channels). See Configuring MADI support with a GV Node Device , on page 169 for more information.

Parameter	Description
Redundancy Port	Associate this port with another port to create a redundant network traffic flow path for failover protection. The associated port will not be available to carry other traffic.
GV Node-[instance] Out #	
Name	The name or identifier for this SDI output.
Automatic Source	Set to automatically create a source by the system using the specified stream.
Bandwidth (bps)	The stream's data rate.
IGMPv3 SSM Address	Source Specific Multicast address as per IGMPv3 (Internet Group Management Protocol) protocol.
IP Stream Prototype #	
Name	The name or identifier for this SDI output.
Flow Type	Set the content type for this stream: Audio, Data, or Video.
SDP	The Session Description Protocol is a format for describing streaming media communications parameters.
Eth In #.#	
Name	The name or identifier for this IP input.
# Streams	The number of streams for this IP input.
Port Identifier	An input lane is specified as QSPFport.lane which in turn corresponds to a physical port on the router. The number property specifies which physical port it is. The port identifier is how you name it so that you can refer to it.
Number	Set the port number on the router.
Direction	This shows the current status for information purposes.
Connector Type	
Capacity (bps)	The stream's data rate.
GV Node-[instance] Eth In#.# Stream #	
Name	The name or identifier for this IP input.
Flow Type	Set the content type for this stream: Audio, Data, or Video.
Automatic Source	Set to automatically create a source by the system using the specified stream.
SDP	The Session Description Protocol is a format for describing streaming media communications parameters.
IGMPv3 SSM Address	Source Specific Multicast address as per IGMPv3 (Internet Group Management Protocol) protocol.
IP Address	The stream's network IP address.
IP Port	Port number for the stream.
In#	

Parameter	Description
Name	The name or identifier for this IP input.
# Streams	The number of streams for this IP input.
Port Identifier	An input lane is specified as QSPFport.lane which in turn corresponds to a physical port on the router. The number property specifies which physical port it is. The port identifier is how you name it so that you can refer to it.
Number	Set the port number on the router.
Direction	This shows the current status for information purposes.
Connector Type	
Capacity (bps)	The stream's data rate.
Bandwidth Usage (bps)	The stream's data rate.
IP Address	The stream's network IP address.
Mods-In to IFM	This option sets the expected input signal type: SDI: The input signal is a standard SDI video signal with embedded audio. MADI: The input signal is a MADI signal (supports 64 audio channels). See Configuring MADI support with a GV Node Device , on page 169 for more information.
Redundancy Port	Associate this port with another port to create a redundant network traffic flow path for failover protection. The associated port will not be available to carry other traffic.
GV Node-[instance] In#	
Name	The name or identifier for this IP input.
Automatic Source	Set to automatically create a source by the system using the specified stream.
IGMPv3 SSM Address	Source Specific Multicast address as per IGMPv3 (Internet Group Management Protocol) protocol.
Eth Out #.#	
Name	The name or identifier for this IP input.
# Streams	The number of streams for this IP input.
Port Identifier	An input lane is specified as QSPFport.lane which in turn corresponds to a physical port on the router. The number property specifies which physical port it is. The port identifier is how you name it so that you can refer to it.
Number	Set the port number on the router.
Direction	This shows the current status for information purposes.
Connector Type	
Capacity (bps)	The stream's data rate.

Parameter	Description
Bandwidth Usage (bps)	The stream's data rate.
IP Address	The stream's network IP address.
Redundancy Port	Associate this port with another port to create a redundant network traffic flow path for failover protection. The associated port will not be available to carry other traffic.
GV Node-[instance] Out#.# Stream #	
Name	The name or identifier for this IP input.
IP Address	The stream's network IP address.
IP Port	Port number for the stream.
Flow Type	Set the content type for this stream: Audio, Data, or Video.
Automatic Source	Set to automatically create a source by the system using the specified stream.
SDP	The Session Description Protocol is a format for describing streaming media communications parameters.
Bandwidth (bps)	The stream's data rate.
IGMPv3 SSM Address	Source Specific Multicast address as per IGMPv3 (Internet Group Management Protocol) protocol.

Configuring MADI support with a GV Node Device

To support a MADI input on a GV Node frame, this option must be configured both in GV Orbit Control and the MADI input must have been previously configured in iControl Navigator; locate the GV Node Manager associated with your GV Node and double-click its icon. For example, the following figure shows the 9th input XIO-4901 card in slot 16 is set to accept a MADI input. Within GV Orbit Control, the same setting must be made wherever a MADI input has been configured in iControl Navigator for a GV Node frame.

Module Inputs -Tx Streams				Module Outputs -Rx Streams									
Slot#	Main Module	Rear panel	Enabled Options	Module Inputs (Mod-In) to Internal Fabric Module (IFM)									
				1	2	3	4	5	6	7	8	9	
1	XIO-4901	XIO-4901-4SRP-D	MDX	MDX	MDX	MDX	MDX	MDX	MDX	MDX	MDX	MDX	MDX
2	KMX-4911	KMX-49N1-9x2-4...	MDX	SDI	SDI								
3	KMX-4911	KMX-49N1-9x2-4...	MDX	SDI	SDI								
4	XIO-4901	XIO-4901-4SRP-D	MDX	MDX	MDX	MDX	MDX	MDX	MDX	MDX	MDX	MDX	MDX
5	Empty												
6	Empty												
7	Empty												
8	Empty												
9	SME-1911												
10	Empty												
11	XVP-3901												
12	Empty												
13	HDA-3931												
14	XIO-4901	XIO-4901-4SRP-D	MDX	MDX	MDX	MDX	MDX	MDX	MDX	MDX	MDX	MDX	MDX
15	Empty												
16	XIO-4901	XIO-4901-4SRP-D	None	SDI	SDI	SDI	SDI	SDI	SDI	SDI	SDI	SDI	MADI

Module Inputs (Mod-In) to Aggregation Ports (Agg-Tx)					
Video Streams		Ancillary Data Streams		Audio Streams	
Mod-In	Agg-Tx	Mod-In	Agg-Tx	Mod-In	Agg-Tx
39	72	27	72	31	72

Fig. 4-1: A GV Node in iControl Navigator

The above iControl Navigator configuration is used as an example configuration for the following procedure.

To configure a GV node MAD I input in GV Orbit Control

- 1 Select the required Area. See [Selecting an Area](#), on page 23.
- 2 Select the required topology. See [Selecting a Graph](#), on page 25.
- 3 Add and configure a GV Node device. See [Configuring a GV Node Device](#), on page 163.
- 4 In the **Property Editor** for the GV Node device, make the same setting as in GV Node Manager for **Enabled Options** for the card: in the GV Node’s properties, in **Slots**, select **16**, then set **None** in **Card Enabled Option**.

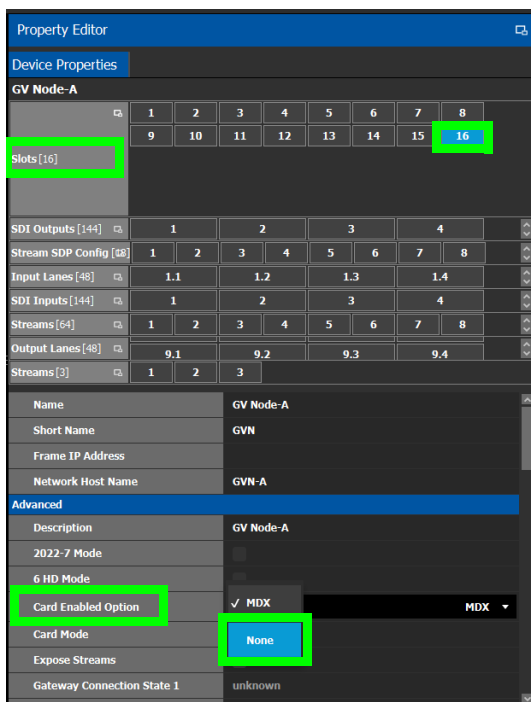

- 5 Use the following table to identify the SDI input number used by GV Orbit Control from the card’s slot and input number for the next step. Only the eighth and ninth inputs of each slot support MAD I input signals. For example, the ninth input of the card in slot 16 is 144.

Matrix Input from Fabric Number for each GV Node Frame Slot

Card’s Input from GV Node Fabric	GV Node Frame Slot Number															
	1	2	3	4	5	6	7	8	9	10	11	12	13	14	15	16
First Input	1	10	19	28	37	46	55	64	73	82	91	100	109	118	127	136
Second Input	2	11	20	29	38	47	56	65	74	83	92	101	110	119	128	137
Third Input	3	12	21	30	39	48	57	66	75	84	93	102	111	120	129	138
Fourth Input	4	13	22	31	40	49	58	67	76	85	94	103	112	121	130	139
Fifth Input	5	14	23	32	41	50	59	68	77	86	95	104	113	122	131	140
Sixth Input	6	15	24	33	42	51	60	69	78	87	96	105	114	123	132	141

Matrix Input from Fabric Number for each GV Node Frame Slot (continued)

Card's Input from GV Node Fabric	GV Node Frame Slot Number															
	1	2	3	4	5	6	7	8	9	10	11	12	13	14	15	16
Seventh Input	7	16	25	34	43	52	61	70	79	88	97	106	115	124	133	142
Eighth Input	8	17	26	35	44	53	62	71	80	89	98	107	116	125	134	143
Ninth Input	9	18	27	36	45	54	63	72	81	90	99	108	117	126	135	144

- In the **Property Editor** for the GV Node device, make the same setting as in GV Node Manager for the card's input: in the GV Node's properties, in **SDI Inputs**, select **144**, then set **MADI in Mods-In** to **IFM**.

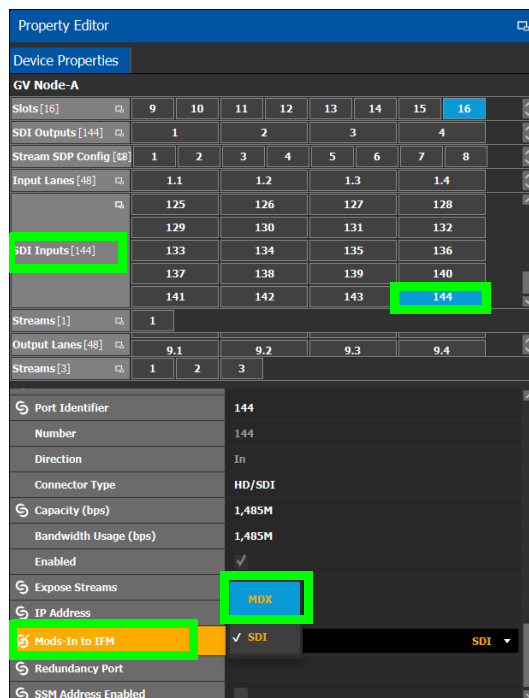

For each MADI input, 64 audio streams are shown in **Streams** and the logical level is MADI for each stream. These 64 streams are made available within the Logical Device Table for use on manually created logical devices. If you choose the Automatic source/destination option for the MADI, then 4 devices of 16 channels of audio are

created in the Logical Device Table on the appropriate tab. See [Logical Device Table Tasks](#), on page 72.

The screenshot shows the 'Property Editor' window for a 'GV Node-A 10.37.73.211' device. The 'Device Properties' tab is selected, displaying a grid of configuration options. A red box highlights the 'Streams [64]' row, and a blue box highlights the 'Logical Level' property set to 'MADI'.

Property	1	2	3	4	5	6	7	8	9	10	11	12	13	14	15	16
Slots [16]	1	2	3	4	5	6	7	8	9	10	11	12	13	14	15	16
Stream SDP Config [48]	1	2	3	4	5	6	7	8	9	10	11	12	13	14	15	16
SDI Outputs [144]	1	2	3	4	5	6	7	8	9	10	11	12	13	14	15	16
Input Lanes [48]	1.1	1.2	1.3	1.4	2.1	2.2	2.3	2.4	3.1							
SDI Inputs [144]	100	101	102	103	104	105	106	107	108							
	109	110	111	112	113	114	115	116	117							
	118	119	120	121	122	123	124	125	126							
	127	128	129	130	131	132	133	134	135							
Streams [64]	136	137	138	139	140	141	142	143	144							
	3.2	3.3	3.4	4.1	4.2	4.3	4.4	5.1	5.2							
	5.3	5.4	6.1	6.2	6.3	6.4	7.1	7.2	7.3							
	7.4	8.1	8.2	8.3	8.4	9.1	9.2	9.3	9.4							
Output Lanes [48]	10.1	10.2	10.3	10.4	11.1	11.2	11.3	11.4	12.1							
	12.2	12.3	12.4													

Redundancy Port

SSM Address Enabled

GV Node-A 10.37.73.211 In 144 Stream 1

Name: GV Node-A 10.37.73.211 In 144 Stream 1

Description: GV Node-A 10.37.73.211 In 144 Stream 1

Logical Level: **MADI**

Automatic Source

Automatic Destination

Enabled:

Expose Stream

IGMPv3 SSM Address: 0.0.0.0

SSM Address Enabled

Configuring an IPG-3901 / IPG-4901 Device

The Densité IP Gateway (IPG-3901) plug-and-play module is a 3 RU module for the Densité 3 frame, which provides bidirectional IP/SDI conversion. The Gateway operates with 10 GigE audio/video video-over-IP, supporting UHD/3G/HD/SD-SDI formats.

The GV Node IP Gateway (IPG-4901) plug-and-play module is a 3 RU single slot module for the GV Node frame, which provides bidirectional fiber IP connectivity to provide conversion to and from other equipment that cannot be handled directly by the GV Node aggregation ports (GV Node's receivers and transmitters). This card allows you to expand the receivers available on the GV Node, as well as it brings more flexibility to the allowed audio profiles that can be accepted through the IPG-4901

PREREQUISITES: All IPG-3901 and IPG-4901 devices must have been previously configured in iControl Navigator. GV Orbit Control reads this configuration information from iControl through the GV Node / Densité Manager.

To configure an IPG-3901 / IPG-4901 Device

- 1 Add the **IPG-3901** or **IPG-4901** device to the Topology: from the **Device Library, Virtual Device**, find the **IPG-3901** or **IPG-4901** device bubble. See [To add a Virtual Device to a topology](#), on page 44.

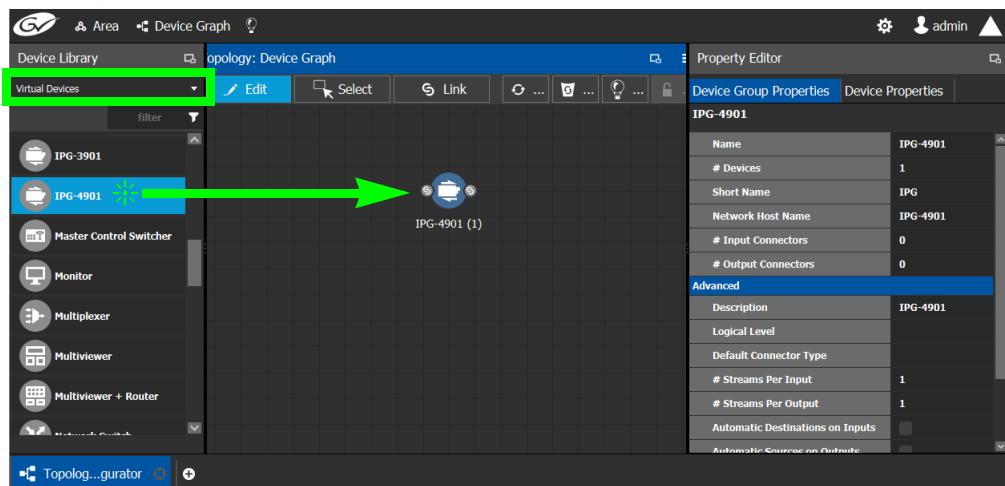

- 2 Select **Device Group Properties**. Configure the **GV Node IP Address / Frame IP Address** and **Slot Number** properties.

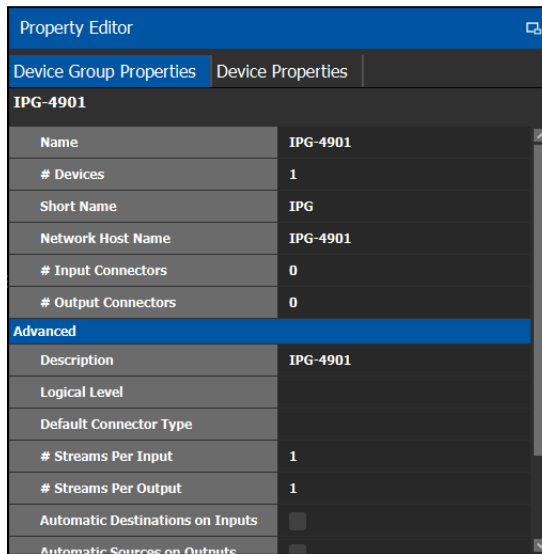

See also [Description of Common Device Properties](#), on page 162.

Parameter	Description
# Devices	The number of panel instances in this device group.
Network Host Name	The hostname is the unique name by which the associated IPG-3901 or IPG-4901 is known on the network.
# Input Connections	The current status for information purposes, once the GV Node IP Address and Slot Number parameters are configured and the topology is activated. See Activating a Topology , on page 66.
# Output Connections	
Advanced > Default Connector Type	
Advanced > # Streams Per Input	
Advanced > # Streams Per Output	
Advanced > Receive Stream IP Pattern	
Advanced > Send Stream IP Pattern	

- 3 Activate the topology. See [Activating a Topology](#), on page 66.
 The card configuration is read from Densité Manager and applied to the device.

- 4 Select the **Device Properties** tab and then select **IPG** next to **Devices**. See also [Description of Common Device Properties](#), on page 162.

Parameter	Applies to		Description
	IPG-3901	IPG-4901	
Network Host Name	•	•	The hostname is the unique name by which the associated IPG-3901 or IPG-4901 is known on the network.
GV Node IP Address		•	IP Address of the CPU-ETH3 for the GV Node frame into which the IPG-4901 card is installed.
Frame IP Address	•		IP Address of the CPU-ETH3 for the Densité frame into which the IPG-3901 card is installed.
Slot Number	•	•	The slot in which the IPG-3901 or IPG-4901 device is located in the GV Node frame.
Connection to Controller 1	•	•	Connection to Controller 1 shows the connection status of the IPG device with the primary server of a server group.
Connection to controller 2	•	•	Connection to Controller 2 shows the connection status of the IPG device with the secondary server of a server group. See Configuring a Controller Group , on page 19. unknown: The topology is inactive (see Activating a Topology , on page 66) or the IPG device does not have network connectivity to the GV Orbit Server(s). offline: The IPG device does not have network connectivity to the GV Orbit Server(s). online: The IPG device is connected to the GV Orbit Server(s).
Firmware Version	•	•	Shows the firmware version installed on the IPG-3901 or IPG-4901 card. This shows the current status for information purposes.
Internal Wiring Done	•	•	Shows if the internal modeling of the IPG-3901 or IPG-4901 is complete.
Operation Mode	•	•	Shows the operation mode of the ETH2 port of the IPG-3901 or IPG-4901 card for information purposes: Redundancy: ETH 2 is redundant to ETH 1. Aggregation: Both ETH 1 and ETH 2 are available simultaneously. OFF: ETH 2 is disabled.

- 5 Select **ETH#** next to **Ethernet Ports**. These are the network configuration parameters for the IPG-3901 or IPG-4901 card's Ethernet ports. See also [Description of Common Device Properties](#), on page 162.

Parameter	Description
IP Address	The network IP address for this Ethernet port.
Gateway	The network gateway IP address.
Subnet Mask	The IP network's subnet mask.

- 6 Select one of the streams next to **Gateways** (by default labelled as **OUT#** or **IN#**). See also [Description of Common Device Properties](#), on page 162.

Parameter	Description
Direction	This shows the current status for information purposes.
Logical Level on SDI Stream	To force a stream to use the IPG-3901 or IPG-4901 device, create a new level (see Duplicating a Logical Level , on page 33) that you will use to select these specific streams at the source and destination ports. Set the logical level that will be used for this here. For example, create a logical level called IPG-SDI from the SDI logical level. Now use this level to send and receive streams to and from this device.

- 7 Select **1** or **2** next to **Streams**. See also [Description of Common Device Properties](#), on page 162.

Parameter	Description
Ethernet Port	The Ethernet port this gateway is assigned to (ETH 1 or ETH 2). This shows the current status for information purposes.
Format	The gateway format: SD, HD, or 3G for video streams, or AES67 profile for audio streams. This shows the current status for information purposes.
IGMPv3 Source	For a receiver gateway, this is the address of the joined stream's port when SSM Address is enabled on the device.
IP Address	The stream's network IP address.
Logical Level on ETH stream	The Logical level to apply on the ETH side of the gateway. By default for the video stream, this value is SDI and for the audio stream, this value is SDI audio.
Port	The stream's network port.
Redundant IGMPv3 Source	When the IPG-3901 or IPG-4901 card is in Redundancy mode: For a receiver gateway, this is the address of the joined stream's port when SSM Address is enabled on the device.

Parameter	Description
Redundant IP Address	When the IPG-3901 or IPG-4901 card is in Redundancy mode: The stream's network IP address.
Redundant Port	When the IPG-3901 or IPG-4901 card is in Redundancy mode: The stream's network port.

Connecting an IPG-4901 device

The IPG 4901 has 9 SDI input ports, 9 SDI output ports, and 2 bidirectional ETH ports. The SDI ports must be connected to the SDI ports of the GV Node in which the IPG-4901 is slotted in. This rule is not enforced in GV Orbit Control. GV Orbit Control allows you to use an IPG-4901 like an IPG-3901, however this is not a valid use case and will not work.

The 9 SDI input ports short labels are called OUT for OUT from fabric, and the 9 SDI output ports short labels are called IN for In to fabric to follow iControl's behavior.

Device properties

- It is possible to assign a logical level to SDI ports by changing the Logical Level of SDI stream at the Gateway level.
- It is possible to assign a logical level to IP streams by changing the Logical Level on ETH stream on Stream level, under the Gateway.
- It is possible to change the multicast address for SDI to IP gateways (called OUT) by changing the IP Address, Port, Redundant IP Address and Redundant Port properties on Stream level, under Gateway. These changes are propagated to iControl.
- In OFF or Redundancy mode, gateways OUT 6 to 9 and IN 6 to 9 are disabled and not visible in **Property Editor**. They become visible only if card is in Aggregation mode.

Example Topology Using an IPG-4901

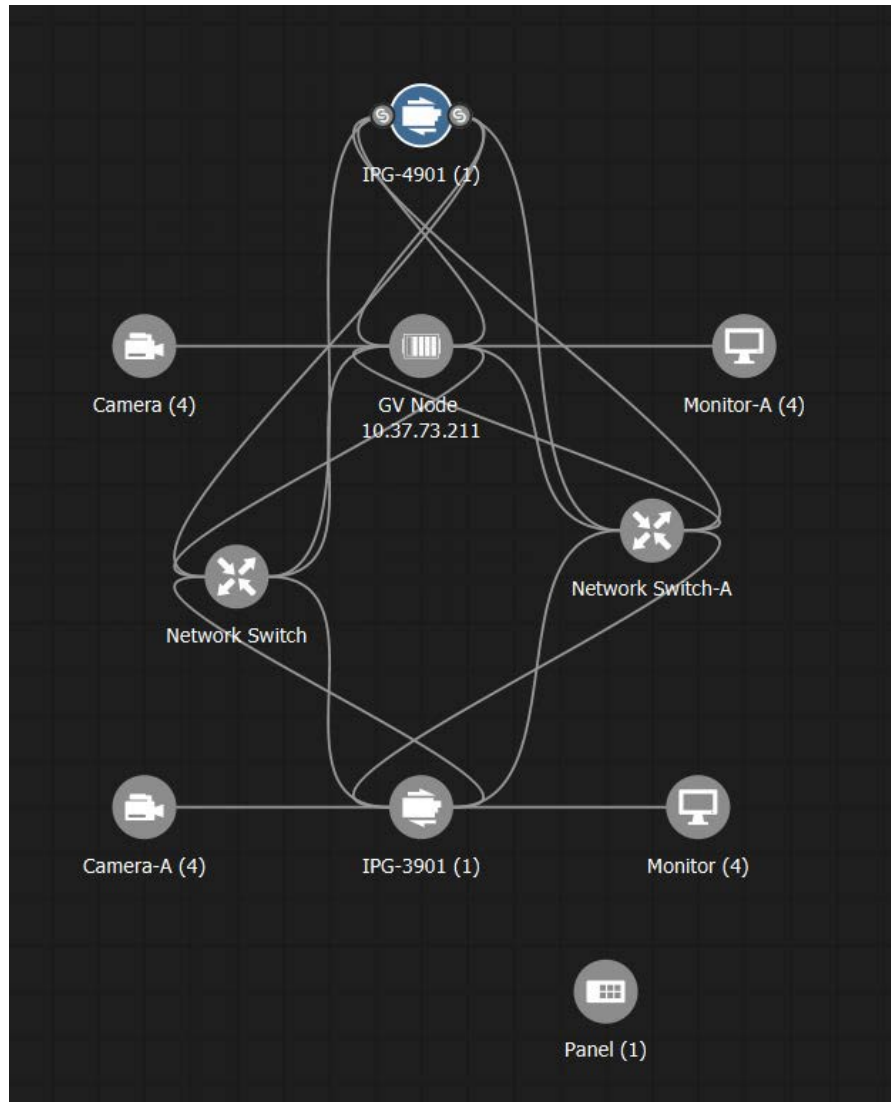

Configuring an IPVU Device

The IPVU is a compact dual-channel IP-to-HDMI converter that is perfect for displaying IP sources and a multiviewer's IP outputs on HD and UHD HDMI displays.

The inputs of an IPVU are called *spigots*. See also [How to Know if a Spigot is an Input or an Output](#), on page 184.

WARNING

The IPVU's configuration is set through RollCall and then GV Orbit Control reads the configuration from the IPVU device. All spigots on an IPVU are inputs.

There is no offline configuration of the IPVU device. It must first be discovered on the network by GV Orbit Control.

The IPVU device must have been previously configured with RollCal before being integrated into GV Orbit Control as most configuration parameters shown in GV Orbit Control are for information purposes only (GV Orbit Control reads it from the IPVU devices). See the *IPVU Installation Guide* for more information.

PREREQUISITES: The Domain ID of the IPVU device(s) must be set in the System Controller Group Properties under **Domain Ids**. See [Configuring a Controller Group](#), on page 19. These devices must be on the same subnet that the GV Orbit Server is connected to.

Related Topics

- [How to Know if a Spigot is an Input or an Output](#), on page 184.
- [Configuring UHD 4K Two-Sample Interleave Division IP Streams for use with an IQMix, IQUCP, UCP-3901, or IPVU Device](#), on page 185.
- [Configuring UHD 4K Quad-Link SDI Streams for use with an IQMix, IQUCP, UCP-3901, or IPVU Device](#), on page 190.

Spigot Usage

An IPVU device has 8 input spigots. They are used according to the IPVU's output resolution.

Input Spigot Number	HD Output Description	UHD Output Description
Spigot1	Stream input for Monitor Output 1 connection	SMPTE ST 424-5 Link 1 input stream for Monitor Output 1 output connection
Spigot2	Not used	SMPTE ST 424-5 Link 2 input stream for Monitor Output 1 output connection
Spigot3	Not used	SMPTE ST 424-5 Link 3 input stream for Monitor Output 1 output connection
Spigot4	Not used	SMPTE ST 424-5 Link 4 input stream for Monitor Output 1 output connection
Spigot5	Stream input for Monitor Output 2 connection	SMPTE ST 424-5 Link 1 input stream for Monitor Output 2 output connection
Spigot6	Not used	SMPTE ST 424-5 Link 2 input stream for Monitor Output 2 output connection

Input Spigot Number	HD Output Description	UHD Output Description
Spigot7	Not used	SMPTE ST 424-5 Link 3 input stream for Monitor Output 2 output connection
Spigot8	Not used	SMPTE ST 424-5 Link 4 input stream for Monitor Output 2 output connection

To configure an IPVU Device

- 1 Add the IPVU device to the Topology: from the **Device Library, Discovered**, find an IPVU device bubble that you want to control. See [To add a Discovered Device to a Topology](#), on page 48.

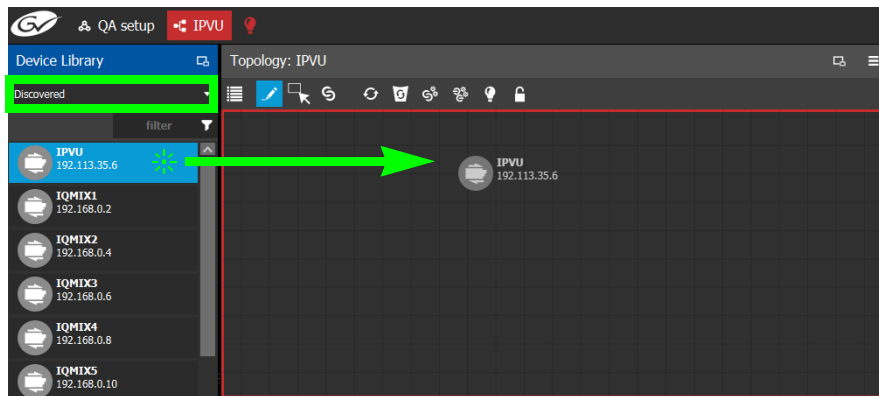

- 2 Configure the IPVU properties. See also [Description of Common Device Properties](#), on page 162. The IPVU device should be first configured with RollCall before being integrated into GV Orbit Control as most configuration parameters shown in GV Orbit Control are shown for information purposes only.

Parameter	Description
Network Host Name	The hostname is the unique name by which the associated IPVU is known on the network.
Domain ID	Set the same Domain IDs on all IPVU devices that are to communicate with each other on the network. The default value for Grass Valley equipment is 101 . Valid range: 0 to 232. See also Configuring a Controller Group , on page 19.
Internal wiring	Shows if the internal modeling of the IPVU is complete.

- 3 Create and connect the core IP devices to the IPVU. See [Methods to Link Devices in a Topology](#), on page 53.

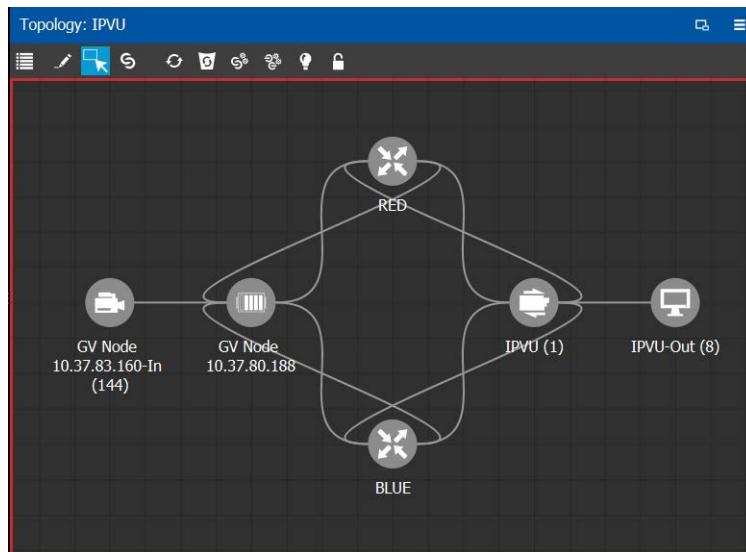

Configuring an IQMix, IQUCP, or UCP-3901 Device

The IQMIX / IQUCP / UCP-3901 series is a range of multi-channel video over IP transceiver modules developed for use within low latency, high bandwidth Ethernet IP networks, capable of encoding / decoding multiple SDI signals. They provide both compressed and uncompressed modes of operation.

The inputs and outputs of an IQMIX / IQUCP / UCP-3901 are called *spigots*. There are a variety of spigot configurations that are available; for example, 6 inputs / 6 outputs, 12 inputs / 0 outputs, 0 inputs / 12 outputs, 8 inputs / 0 outputs. See also [How to Know if a Spigot is an Input or an Output](#), on page 184.

WARNING

The spigot configuration is set through RollCall and then GV Orbit Control reads it from the IQMIX / IQUCP / UCP-3901 card. For any given spigot, you must know which mode (input or output) has been configured to connect the spigots correctly in GV Orbit Control.

There is no offline configuration of the IQMIX / IQUCP / UCP-3901 device. It must first be discovered on the network by GV Orbit Control.

The IQMIX / IQUCP / UCP-3901 device must have been previously configured with RollCall before being integrated into GV Orbit Control as most configuration parameters shown in GV Orbit Control are for information purposes only (GV Orbit Control reads it from the IQMIX / IQUCP / UCP-3901 devices). See the IQMIX / IQUCP / UCP-3901 User Manual for more information.

PREREQUISITES: The Domain ID of the IQMIX / IQUCP / UCP-3901 device(s) must be set in the System Controller Group Properties under **Domain Ids**. See [Configuring a Controller Group](#), on page 19. These devices must be on the same subnet that the GV Orbit Server is connected to.

Note: An IQMix using VC2 video compression format is not currently supported by GV Orbit Control.

Related Topics

- [How to Know if a Spigot is an Input or an Output](#), on page 184
- [Configuring UHD 4K Two-Sample Interleave Division IP Streams for use with an IQMix, IQUCP, UCP-3901, or IPVU Device](#), on page 185.
- [Configuring UHD 4K Quad-Link SDI Streams for use with an IQMix, IQUCP, UCP-3901, or IPVU Device](#), on page 190

To configure an IQMIX / IQUCP / UCP3901 Device

- 1 Add the IQMIX / IQUCP / UCP-3901 device to the Topology: from the **Device Library, Discovered**, find an IQMIX / IQUCP / UCP-3901 device bubble that you want to control. See [To add a Discovered Device to a Topology](#), on page 48.

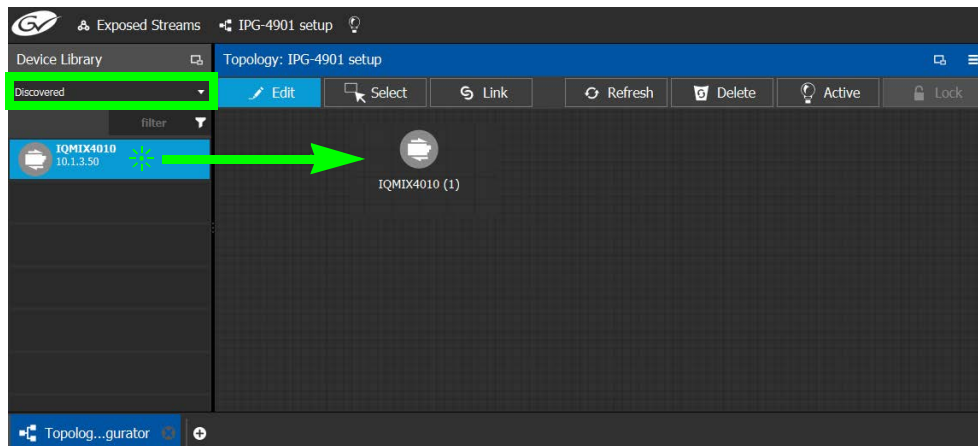

- 2 Configure the IQMIX / IQUCP / UCP-3901 properties. See also [Description of Common Device Properties](#), on page 162. The IQMIX / IQUCP / UCP-3901 device should be first configured with RollCall before being integrated into GV Orbit Control as most configuration parameters shown in GV Orbit Control are shown for information purposes only.

Parameter	Description
Network Host Name	The hostname is the unique name by which the associated IQMIX / IQUCP / UCP-3901 is known on the network.
Domain ID	Set the same Domain IDs on all IQMIX / IQUCP / UCP-3901 devices that are to communicate with each other on the network. The default value for Grass Valley equipment is 101 . Valid range: 0 to 232. See also Configuring a Controller Group , on page 19.
Internal wiring	Shows if the internal modeling of the IQMIX / IQUCP / UCP-3901 is complete.

- 3 Create and connect the edge devices (SDI and IP devices) that are connected to the IQMIX / IQUCP / UCP-3901. See [Methods to Link Devices in a Topology](#), on page 53.

How to Know if a Spigot is an Input or an Output

To know if a spigot In GV Orbit Control is an input or output, proceed as follows:

- 1 Select the device bubble on the Topology Configurator. See [Selecting a Graph](#), on page 25.
- 2 Expand **Ip Spigots** in **Device Properties** and select a spigot from the list.
- 3 For each spigot, interpret the **Mode** property as follows:
 - SRC = Output
 - DST = Input

Configuring UHD 4K Two-Sample Interleave Division IP Streams for use with an IQMix, IQUCP, UCP-3901, or IPVU Device

To support UHD 4K streams, the image is mapped onto four SDI HD sub-images using a two-sample interleave division. This means each of the four sub-stream carries a quarter-resolution picture. These four sub-streams must:

- each be individually represented by four logical levels; one level for each sub-stream. For example, **SDI2Sluhd1**, **video2Sluhd2**, **video2Sluhd3** and **video2Sluhd4**.
 - The first logical level, **SDI2Sluhd1**, carries the full SDI stream for video, audio, and ancillary data.
 - The remaining logical levels will only use the video stream from the SDI levels, **video2Sluhd2**, **video2Sluhd3**, and **video2Sluhd4**.
- be logically linked together so that they are switched together at once ensuring that there is no switching delay between the four streams that would create visible glitches between the four quadrants.

The following shows the typical video stream composition of a two-sample interleave division display with the associated logical levels used in this procedure.

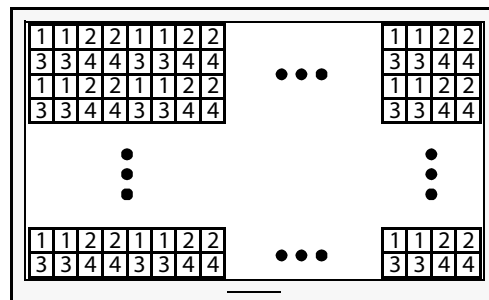

UHD Composite Image

- 1: SMPTE ST 424-5 Link 1 pixels carried by HD Logical Level **SDI2Sluhd1**
- 2: SMPTE ST 424-5 Link 2 pixels carried by HD Logical Level **Video2Sluhd2**
- 3: SMPTE ST 424-5 Link 3 pixels carried by HD Logical Level **Video2Sluhd3**
- 4: SMPTE ST 424-5 Link 4 pixels carried by HD Logical Level **Video2Sluhd4**

PREREQUISITES:

- For IQMix / IQUCP / UCP-3901 devices:
 - The IQMix / IQUCP / UCP-3901 device(s) must already be configured in RollCall. See [Configuring an IQMix, IQUCP, or UCP-3901 Device](#), on page 183.
 - Configure the IQMix / IQUCP / UCP-3901 device spigots to be used for UHD in RollCall by enabling the **UHD Links** parameter in the **Link Control Page** for all quad-link signal spigots.
 - Set the corresponding spigots to use 2SI signals: Under **TPG**, clear (disable) the **SDQS** check boxes as required.

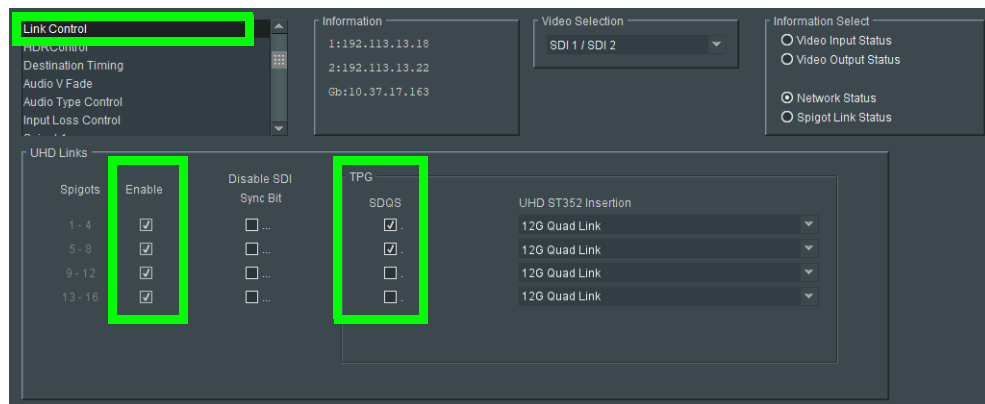

- The IPVU device(s) must already be configured in RollCall. See [Configuring an IPVU Device](#), on page 180.
 - Configure the IPVU device spigots to be used for UHD in RollCall by:
 - Enabling the **Enable UHD** parameter in the **IPVU** configuration page for **Monitor Output 1** and **2** as necessary.
 - Set the **UHD Mode** to **2SI**.

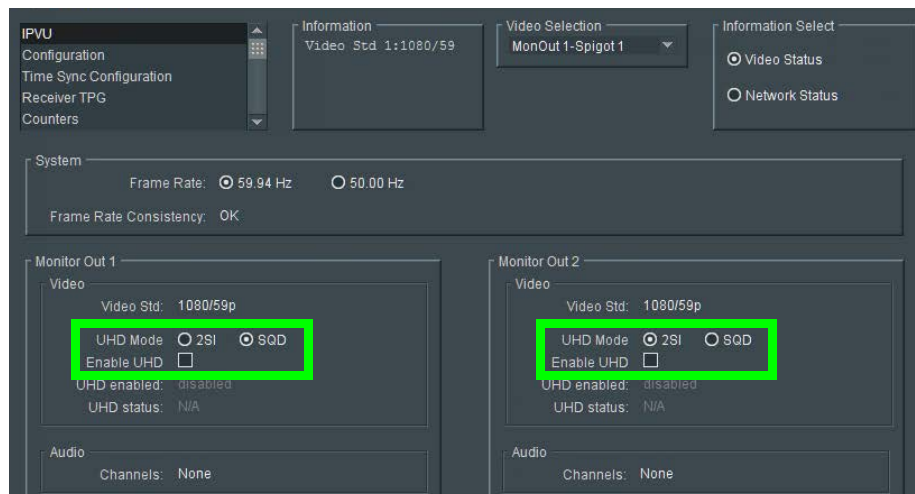

To configure UHD 2SI Streams with an IPVU Device

- 1 Add IPVU device(s) to the topology and configure them in GV Orbit Control. See [Configuring an IPVU Device](#), on page 180.

- 2 Link the IPVU device(s) to the logical sources and destinations in GV Orbit Control. See [Methods to Link Devices in a Topology](#), on page 53.

The following topology will be used as an example, where the IPVU receives UHD stream sources from the GV Node.

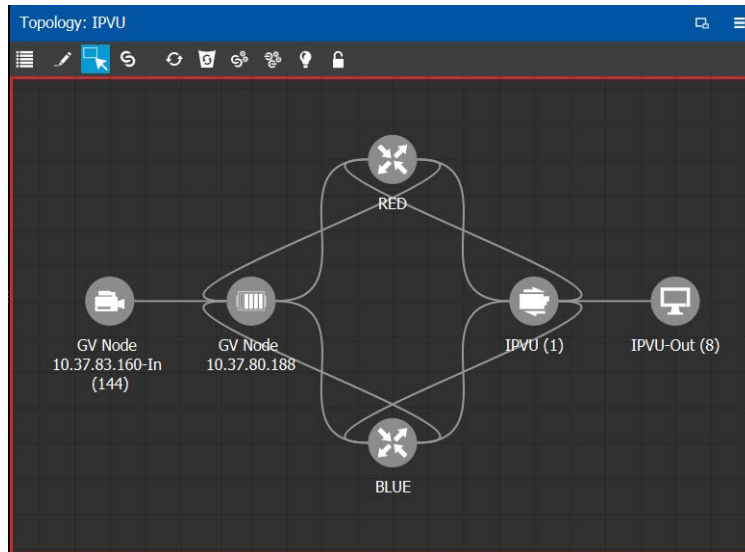

- 3 Create the logical levels necessary to support 2SI sources and destinations: Create the following UHD logical levels from the Logical Level Editor from the pre-existing SDI logical level: **SDI2Sluhd1**, **SDI2Sluhd2**, **SDI2Sluhd3**, and **SDI2Sluhd4**. See [Duplicating a Logical Level](#), on page 33.

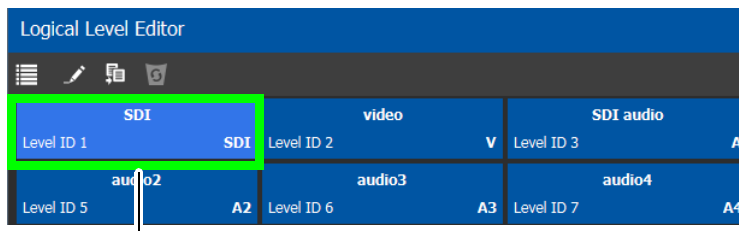

Duplicate the SDI Logical Level four times to create **SDI2Sluhd1**, **SDI2Sluhd2**, **SDI2Sluhd3**, and **SDI2Sluhd4**

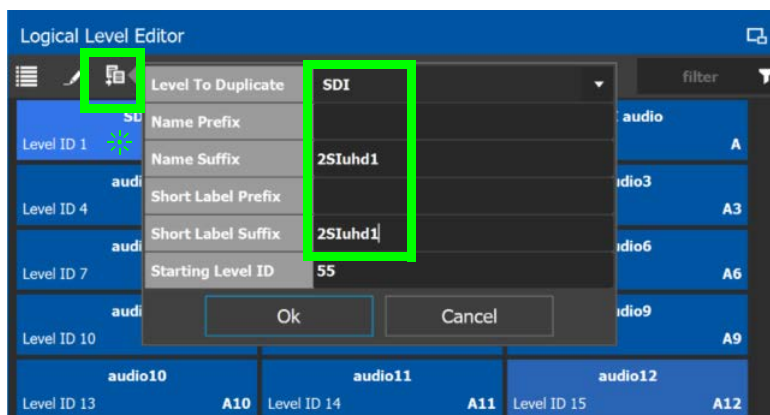

For this example, only the following "2Sluhd" levels will be used: **SDI2Sluhd1**, **Video2Sluhd2**, **Video2Sluhd3**, and **Video2Sluhd4**. It is optional to delete all other

“2Sluhd” logical levels for a cleaner presentation, if they are not used elsewhere. See [Deleting a Logical Level](#), on page 36.

- 4 From the **Multilevel Table** of the **Logical Device Table**, under the **Sources** tab, click the Levels icon . See [Accessing the Logical Device Table task](#), on page 72.
- 5 Select the levels you want to display in the **Logical Device Table**. As shown below, the **2Sluhd** filter was applied and then you can select the 4 Sluhd levels (**SDI2Sluhd1**, **Video2Sluhd2**, **Video2Sluhd3**, and **Video2Sluhd4**), each representing one sub-stream of a of a 2SI signal. Click **OK**.



The columns of the Multilevel Table updates to only show the **SDI2Sluhd1**, **Video2Sluhd2**, **Video2Sluhd3**, and **Video2Sluhd4** columns.

- 6 In the Logical Device Table, select a source’s row to which you want to add the streams. See [To configure streams for the new sources](#), on page 82.

- 7 In the Logical Device Table, map streams with levels: Configure the UHD sources and destinations by assigning quad-link IP streams to each level.

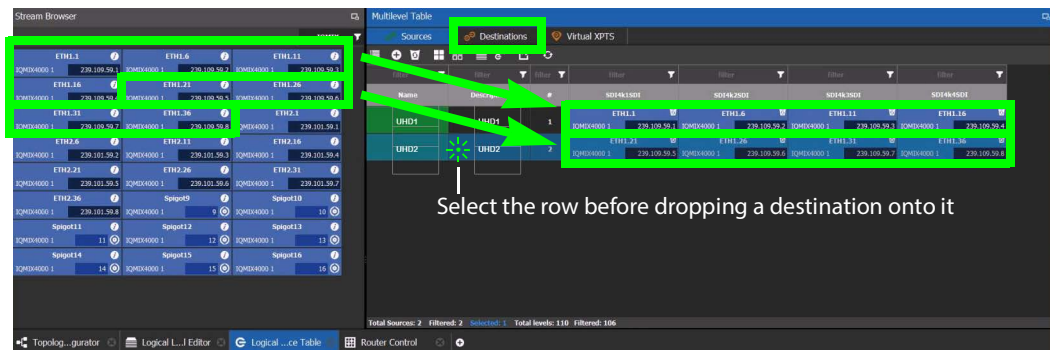

- 8 Select the levels you want to display in the **Logical Device Table**. Again, select the 4 Sluhd levels (**SDI2Sluhd1**, **Video2Sluhd2**, **Video2Sluhd3**, and **Video2Sluhd4**), each representing one sub-stream of a of a 2SI signal. Click **OK**.

The columns of the Multilevel Table updates to only show the **SDI2Sluhd1**, **Video2Sluhd2**, **Video2Sluhd3**, and **Video2Sluhd4** columns.

- 9 From the **Multilevel Table** of the **Logical Device Table**, under the **Destinations** tab, click the Levels icon . See [Accessing the Logical Device Table](#) task, on page 72.
- 10 Repeat step 6 for destinations.
- 11 Test the configuration by making takes between a logical source and destination that use the two-sample interleave division streams. See [Performing a Take in Router Control](#), on page 290. See in Pathfinder that the correct source sub-streams are received by each destination. See [Viewing Information about the Destinations](#), on page 274.

Configuring UHD 4K Quad-Link SDI Streams for use with an IQMix, IQUCP, UCP-3901, or IPVU Device

To support UHD 4K streams, a quad-link (square division) configuration is used. That is, the UHD image is divided into four SDI HD quadrants, and each quadrant is sent as four separate streams. These four streams must:

- each be individually represented by four logical levels; one level for each quadrant. For example, **SDI**, **SDIuhd2**, **SDIuhd3** and **SDIuhd4**.
 - The first logical level is the base **SDI** logical level. This logical level carries the video, audio, and ancillary data.
 - The **SDIuhd2**, **SDIuhd3** and **SDIuhd4** logical levels are video only.
- be logically linked together so that they are switched together at once ensuring that there is no switching delay between the four streams that would create visible glitches between the four quadrants.

The following shows the typical video stream composition of a UHD quad-link display with the associated logical levels used in this procedure.

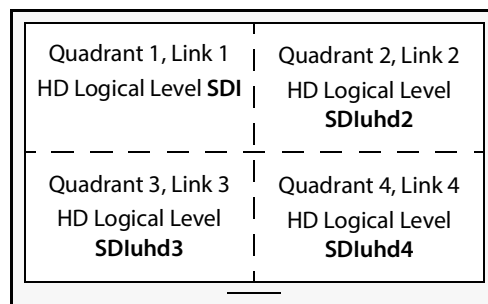

UHD Composite Image

PREREQUISITES:

- For IQMix / IQUCP / UCP-3901 device(s):
 - The IQMix / IQUCP / UCP-3901 device(s) must already be configured in RollCall. See [Configuring an IQMix, IQUCP, or UCP-3901 Device](#), on page 183.
 - Configure the IQMix / IQUCP / UCP-3901 device spigots to be used for UHD in RollCall by enabling the **UHD Links** parameter in the **Link Control Page** for all quad-link signal spigots.
 - Set the corresponding spigots to use Square Division signals: Under **TPG**, set (enable) the **SDQS** check boxes as required.

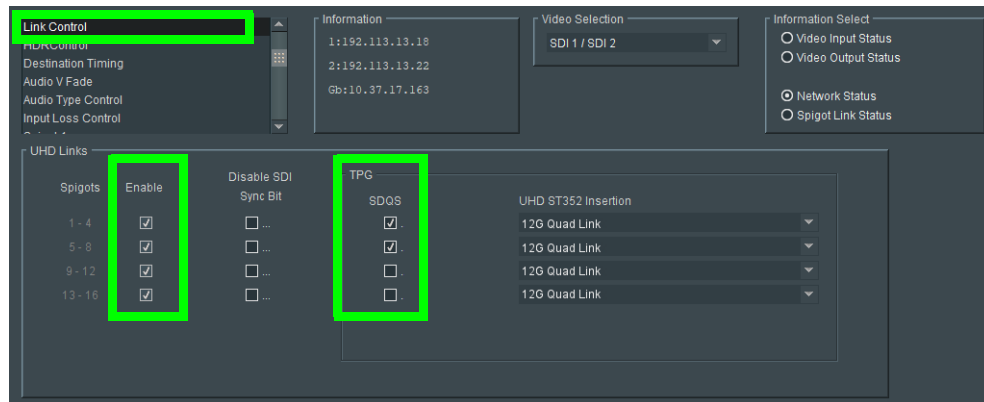

- For IPVU device(s):
 - The IPVU device(s) must already be configured in RollCall. See [Configuring an IPVU Device](#), on page 180.
 - Configure the IPVU device spigots to be used for UHD in RollCall by:
 - Enabling the **Enable UHD** parameter in the **IPVU** configuration page for **Monitor Output 1** and **2** as necessary.
 - Set the **UHD Mode** to **SQD**.

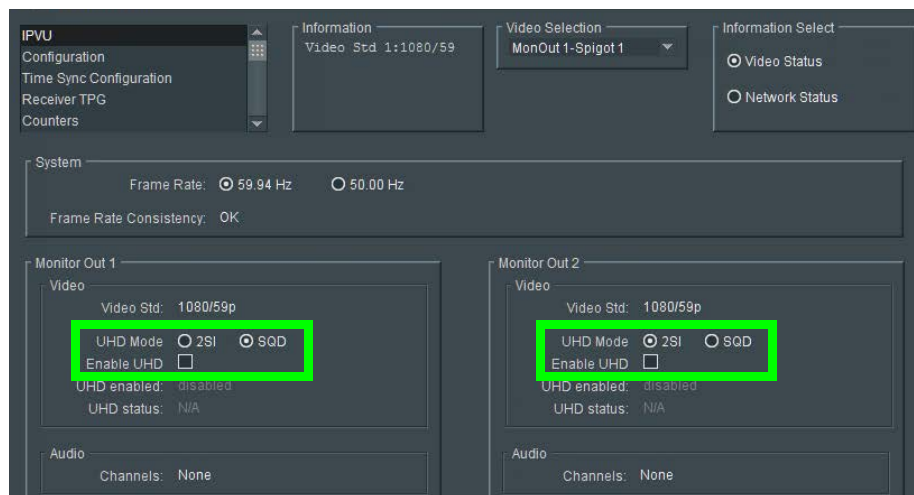

To configure UHD Quad-Link Streams

Create the logical levels necessary to support quad-link sources and destinations.

- 1 Create the following UHD logical levels from the Logical Level Editor from the pre-existing SDI logical level: **SDIuhd1**, **SDIuhd2**, **SDIuhd3** and **SDIuhd4**. See [Duplicating a Logical Level](#), on page 33.

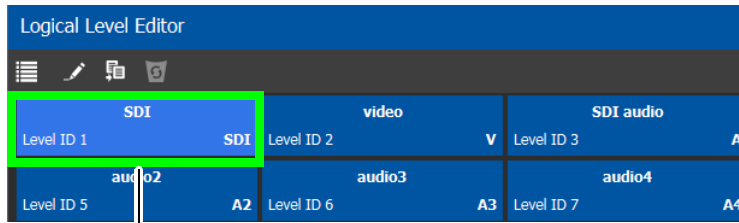

Duplicate the SDI Logical Level four times to create **SDIuhd1**, **SDIuhd2**, **SDIuhd3**, and **SDIuhd4**

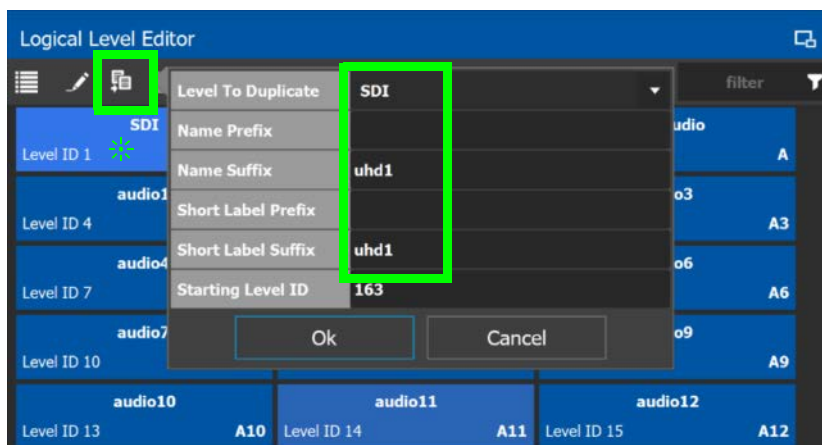

- 2 From the **Multilevel Table** of the **Logical Device Table**, click the Levels icon . See [Accessing the Logical Device Table task](#), on page 72.
- 3 Select the levels you want to display in the table. As shown below, a filter **SDIuhd** was applied and then you can select the 4 SDI UHD levels and click **OK**.



The logical device table will show 4 items (**SDIuhd1**, **SDIuhd2**, **SDIuhd3**, and **SDIuhd4**), each with a UHD level representing one quadrant of a of a quad-link signal.

- 4 Add IQMix / IQUCP / UCP-3901 device(s) to the topology and configure them in GV Orbit Control. See [Configuring an IQMix, IQUCP, or UCP-3901 Device](#), on page 183.
- 5 Link the IQMix / IQUCP / UCP-3901 device(s) to the logical sources and destinations in GV Orbit Control. See [Methods to Link Devices in a Topology](#), on page 53.

The following topology will be used as an example, where the IQMix is used as the UHD stream sources (called *uhd1* and *uhd2*) and the IQUCP is used as the UHD stream destination (called *DEST-uhd*).

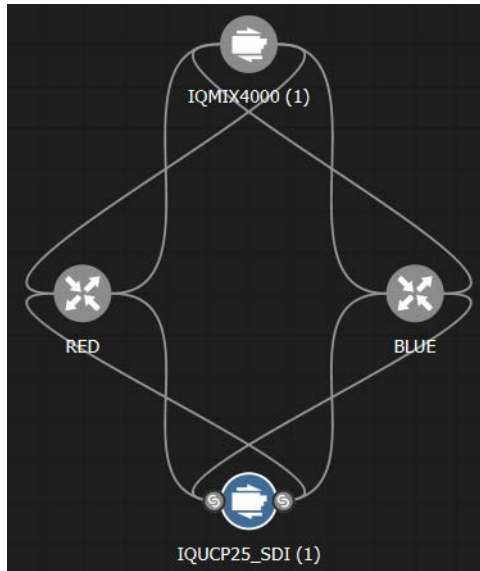

- 6 In the Logical Device Table, map streams with levels: Configure the UHD sources and destinations by assigning quad-link IP streams to each level.

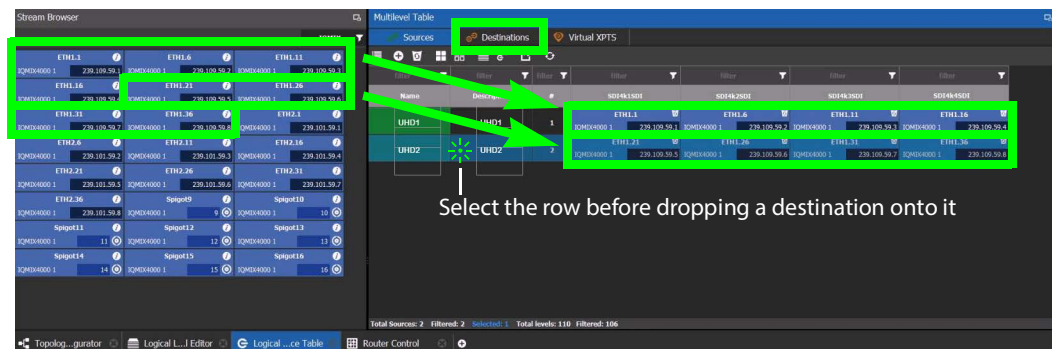

- 7 Repeat step 6 for destinations.
- 8 Test the configuration by making takes between a logical source and destination that use the quad-level link streams. See [Performing a Take in Router Control](#), on page 290. See in Pathfinder that the correct quad-level link streams are received by each destination. See [Viewing Information about the Destinations](#), on page 274.

Configuring an MV-820-IP Multiviewer Device

The MV-820-IP multiviewer has 48 IP inputs and 12 IP outputs in a 2 RU chassis, making it ideal for high-density IP monitoring applications. Internally, the MV-820-IP multiviewer is an MV-820 SDI multiviewer wrapped inside four IQMix cards to provide IP connectivity through a rear panel that supports the QSFP network interface adapters (refer to the MV-820 Multiviewer User Manual, where this is referred to as the *Video IP Circuitry*). These four IQMix cards are used to convert the IP network input streams to feed the 48 × SDI inputs of the MV-820 cards, and uses three of the four same IQMix cards to also convert the 12 × SDI mosaic outputs of the MV-820 cards into IP stream outputs. These IQMix cards are labeled as *MV-820-IP-REAR* in RollCall and GV Orbit Control. See [Configuring an IQMix, IQUCP, or UCP-3901 Device](#), on page 183 for more information about how to configure an IQMix.

The inputs and outputs of an MV-820-IP are called spigots that, within GV Orbit Control, are provided by four MV-820-IP-REAR devices with the following spigot configuration: 48 input spigots across four MV-820-IP-REAR devices and 12 mosaic output spigots across three MV-820-IP-REAR devices. The third MV-820-IP-REAR device has no output spigots.

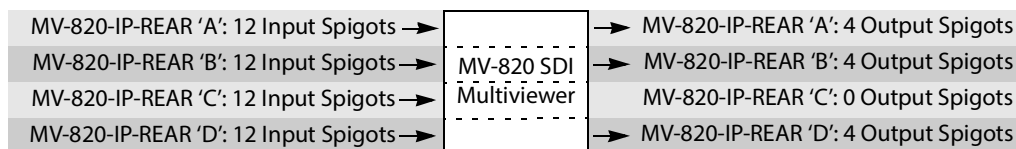

For each MV-820-IP-REAR device, the spigots are used as follows. The third MV-820-IP-REAR device has no output spigots. See also [How to Know if a Spigot is an Input or an Output](#), on page 184.

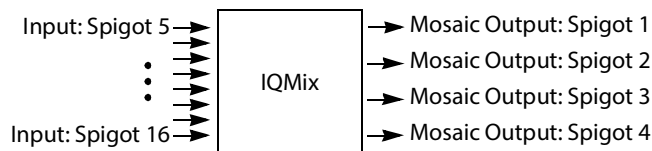

There is no offline configuration of the MV-820-IP device. It must first be discovered on the network by GV Orbit Control.

The MV-820-IP multiviewer must have been previously configured with RollCall before being integrated into GV Orbit Control as most configuration parameters shown in GV Orbit Control are for information purposes only (GV Orbit Control reads it from the MV-820-IP cards). See the MV-820-IP User Guide for more information.

For example, in RollCall 2.5 the MV-820-IP is shown as 4 × MV-820-IP-REAR.

Filter	Spigots	Src Flows	Dest Flows	Router Src Ports	Router Dest Ports	LLDP	LLDP A	LLDP B	Routing Status	Bandwidth Status	Log
(139F7C1E-1D02-1182-87A8-002370008A8C)											
(139F7C1E-1D02-1182-87A8-002370008A8D)											
(13A060CD-1D02-1182-AECF-002370008FC1)											
(13A067D0-1D02-1182-8B38-002370006D66)											
(13A067D0-1D02-1182-8B38-002370006D69)											
(13A067D0-1D02-1182-8B38-002370008FC1)											

PREREQUISITES: The Domain ID of the MV-820-IP devices must be set in the System Controller Group Properties under **Domain Ids**. See [Configuring a Controller Group](#), on

page 19. These devices must be on the same subnet that the GV Orbit Server is connected to.

Note: An MV-820-IP using VC2 video compression format is not currently supported by GV Orbit Control.

To configure an MV-820-IP Multiviewer

- 1 Select the required Area. See [Selecting an Area](#), on page 23.
- 2 Select the required topology. See [Selecting a Graph](#), on page 25.
- 3 The topology must be currently:
 - Activated (see [Activating a Topology](#), on page 66).
 - Unlocked (see [Unlocking / Relocking a Topology](#), on page 69).
- 4 From the **Device Library**, on the left, select **Discovered**, from the drop-down list.

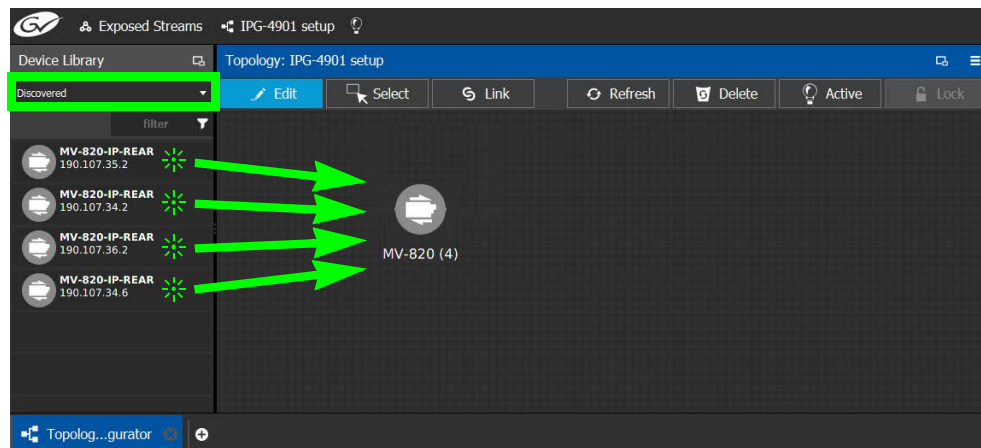

- 5 From the **Device Library**, **Discovered**, find the four **MV-820-IP-REAR** devices with the IP addresses that correspond with those for the MV-820-IP multiviewer on your network: select one of the MV-820-IP-REAR device bubbles and drag it into position on the Topology and release the mouse button.

The device pulled from the **Device Library**, **Discovered** becomes greyed out and another instance of the same device instance cannot be added again to the Topology.

- 6 Now create a device group by adding the remaining three MV-820-IP-REAR device bubbles on top of the MV-820-IP-REAR already on the Topology:
 - a Select another MV-820-IP-REAR device bubble from the **Device Library** and drag it on top of the first MV-820-IP-REAR device instance already on the Topology and release the mouse button.
 - b Repeat this action for the third and fourth MV-820-IP-REAR device bubble in the **Device Library**.

The four MV-820-IP-REAR device instances are shown as a single device on the Topology and can be individually configured in the **Property Editor**, under **Devices**, by clicking an instance. See [Defining Device Properties](#), on page 61 for more information.

- 7 Click on the name of the device underneath the bubble to name the device or device group. See [To name a device and set the number of devices in the group](#), on page 45.

- 8 Configure the MV-820-IP multiviewer's properties. See also [Description of Common Device Properties](#), on page 162. The MV-820-IP device should be first configured with RollCall before being integrated into GV Orbit Control as most configuration parameters shown in GV Orbit Control are shown for information purposes only.

Parameter	Description
Network Host Name	The hostname is the unique name by which the associated MV-820-IP is known on the network.
Domain ID	Set the same Domain IDs on all MV-820-IP devices that are to communicate with each other on the network. The default value for Grass Valley equipment is 101 . Valid range: 0 to 232. See also Configuring a Controller Group , on page 19.
Internal wiring	Shows if the internal modeling of the MV-820-IP is complete.

- 9 Create the logical sources and destinations in GV Orbit Control for the MV-820-IP by adding SDI devices to the topology and then linking them. See [Methods to Link Devices in a Topology](#), on page 53. An example is shown below.

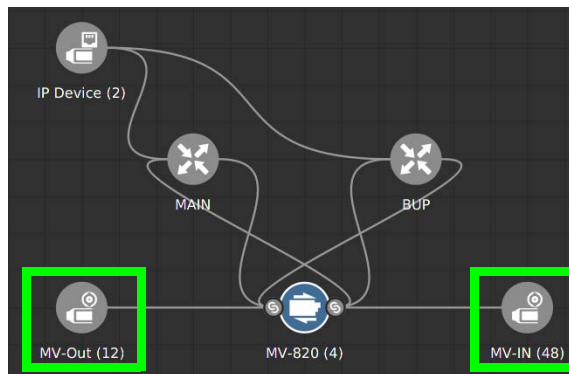

Logical Sources
Represent the
Multiviewer's SDI
Mosaic Outputs

Logical
Destinations
Represent the
Multiviewer's SDI
Inputs

These logical sources and destinations represent the SDI inputs and outputs of the MV-820 multiviewer that will be used when making a take.

- a From the **Device Library, Virtual Devices**, find the **SDI Device** bubble and drag it into position on the Topology and release the mouse button.

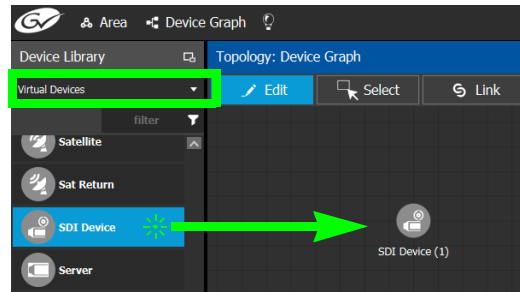

- b Click on the name of the device underneath the bubble to name the device or device group. See [To name a device and set the number of devices in the group](#), on page 45. For example, Enter *MV-Out* in both the **Name** and **Short Name** fields, then enter 12 for the number of device instances. These parameters can also be set in the **Property Editor**.
- c From the **Device Library, Virtual Devices**, find the **SDI Device** bubble and drag it into position on the Topology and release the mouse button.
- d Click on the name of the device underneath the bubble to name the device or device group. For example, Enter *MV-In* in both the **Name** and **Short Name** fields, then enter 48 for the number of device instances.
- e Interconnect the SDI source and destination devices to the proper IQMix spigot SDI inputs and outputs as shown above.

If needed, contact support for more information as how to configure this device. See [Grass Valley Technical Support](#), on page 845.

Configuring a Kahuna IP Production Switcher Device

The Kahuna IP is a production switcher. Internally, the Kahuna IP production switcher is an Kahuna SDI production switcher wrapped inside two IQMix cards to provide IP connectivity. These two IQMix cards are used to convert the IP network input streams to feed the $12 \times$ SDI inputs of the Kahuna, and the other IQMix card to convert the $12 \times$ SDI outputs of the Kahuna into IP stream outputs. These IQMix cards are labelled as *KahunaIP10* and *KahunaPO10* in GV Orbit Control. See [Configuring an IQMix, IQUCP, or UCP-3901 Device](#), on page 183 for more information about how to configure an IQMix.

The inputs and outputs of a Kahuna IP are called *spigots*. There are 12 input and 12 output spigots. In the GV Orbit Control Device Library, the Kahuna IP switcher is discovered as two separate IP devices: the first represents the IP inputs (device type: *KahunaIP10*) and the second represents the IP outputs (device type: *KahunaPO10*).

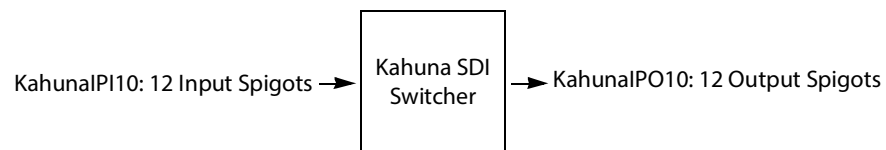

See also [How to Know if a Spigot is an Input or an Output](#), on page 184.

There is no offline configuration of the Kahuna IP device. It must first be discovered on the network by GV Orbit Control.

The Kahuna IP device must have been previously configured with RollCall before being integrated into GV Orbit Control as most configuration parameters shown in GV Orbit Control are for information purposes only (GV Orbit Control reads it from the Kahuna IP device). See the Kahuna IP User Guide for more information.

PREREQUISITES: The Domain ID of the Kahuna IP device(s) must be set in the System Controller Group Properties under **Domain Ids**. See [Configuring a Controller Group](#), on page 19. These devices must be on the same subnet that the GV Orbit Server is connected to.

To configure a Kahuna IP Device

- 1 Select the required Area. See [Selecting an Area](#), on page 23.
- 2 Select the required topology. See [Selecting a Graph](#), on page 25.
- 3 The topology must be currently:
 - Activated (see [Activating a Topology](#), on page 66).
 - Unlocked (see [Unlocking / Relocking a Topology](#), on page 69).

- From the **Device Library**, on the left, select **Discovered** from the drop-down list.

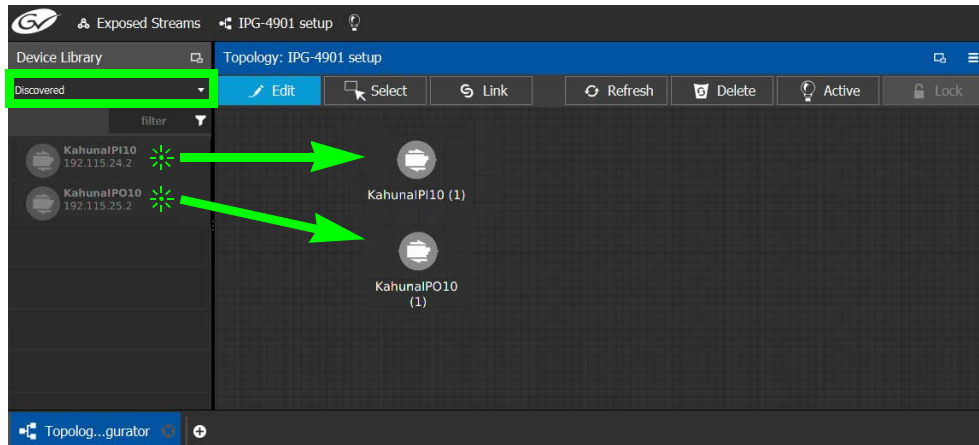

The Kahuna IP is discovered as two separate IP devices: the first represents the IP inputs (device type: KahunaPI10) and the second represents the IP outputs (device type: KahunaIPO10).

- From the **Device Library, Discovered**, find the Kahuna IP input device that you want to control: select the **KahunaPI10** device bubble and drag it into position on the Topology and release the mouse button.
 The device pulled from the **Device Library, Discovered** becomes greyed out and another instance of the same device instance cannot be added again to the Topology.
- From the **Device Library, Discovered**, find the matching **KahunaIPO10** device bubble and drag it into position on the Topology and release the mouse button.
- For each Kahuna IP device (IP inputs device type: **KahunaPI10** and IP outputs device type: **KahunaIPO10**) Click on the name of the device underneath the bubble to name the device. See [To name a device and set the number of devices in the group](#), on page 45.
- Configure the Kahuna IP properties. See also [Description of Common Device Properties](#), on page 162. The Kahuna IP device should be first configured with RollCall before being integrated into GV Orbit Control as most configuration parameters shown in GV Orbit Control are shown for information purposes only.

Parameter	Description
Network Host Name	The hostname is the unique name by which the associated Kahuna IP is known on the network.
Domain ID	Set the same Domain IDs on all Kahuna IP devices that are to communicate with each other on the network. The default value for Grass Valley equipment is 101. Valid range: 0 to 232. See also Configuring a Controller Group , on page 19.
Internal wiring	Shows if the internal modeling of the Kahuna IP is complete.

- 9 Create and connect the edge devices (SDI and IP devices) that are connected to the Kahuna IP. See [Methods to Link Devices in a Topology](#), on page 53. An example is shown below.

Logical Sources
Represent the
Switcher's SDI
Mosaic Outputs

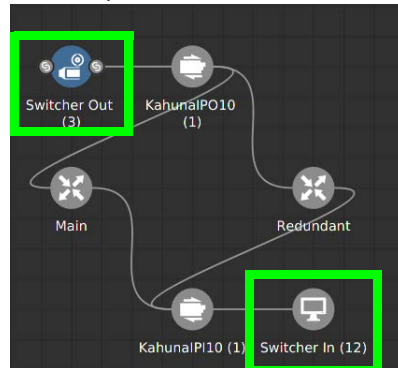

Logical Destinations
Represent the
Switcher's SDI Inputs

These logical sources and destinations represent the SDI inputs and outputs of the Kahuna switcher that will be used when making a take.

- a From the **Device Library, Virtual Devices**, find the **SDI Device** bubble and drag it into position on the Topology and release the mouse button.

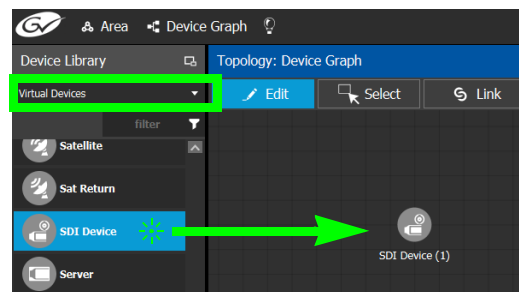

- b Click on the name of the device underneath the bubble to name the device or device group. See [To name a device and set the number of devices in the group](#), on page 45. For example, Enter *Switcher-Out* in both the **Name** and **Short Name** fields, then enter 3 for the number of device instances. These parameters can also be set in the **Property Editor**.
- c From the **Device Library, Virtual Devices**, find the **Monitor Device** bubble and drag it into position on the Topology and release the mouse button.
- d Click on the name of the device underneath the bubble to name the device or device group. For example, Enter *Switcher-In* in both the **Name** and **Short Name** fields, then enter 12 for the number of device instances.
- e Interconnect the SDI source and destination devices to the proper IQMix spigot SDI inputs and outputs as shown above.

If needed, contact support for more information as how to configure this device. See [Grass Valley Technical Support](#), on page 845.

Configuring a K-Frame Production Switcher

The K-Frame is a series of production switchers, and certain models support IP connectivity. The following frames are supported:

- K-Frame-V Production Switcher has 4 slots each providing 8 inputs and 4 outputs to the switcher, for a total of 32 inputs x 16 outputs.
- K-Frame-X Production Switcher has 14 slots. 10 slots each providing 16 inputs and 8 outputs to the switcher, followed by 4 slots each providing 8 inputs and 4 outputs of the switcher, for a total of 192 inputs x 96 outputs.

The following diagram shows a K-Frame-V / K-Frame-X Production Switchers populated with a typical assortment of I/O cards.

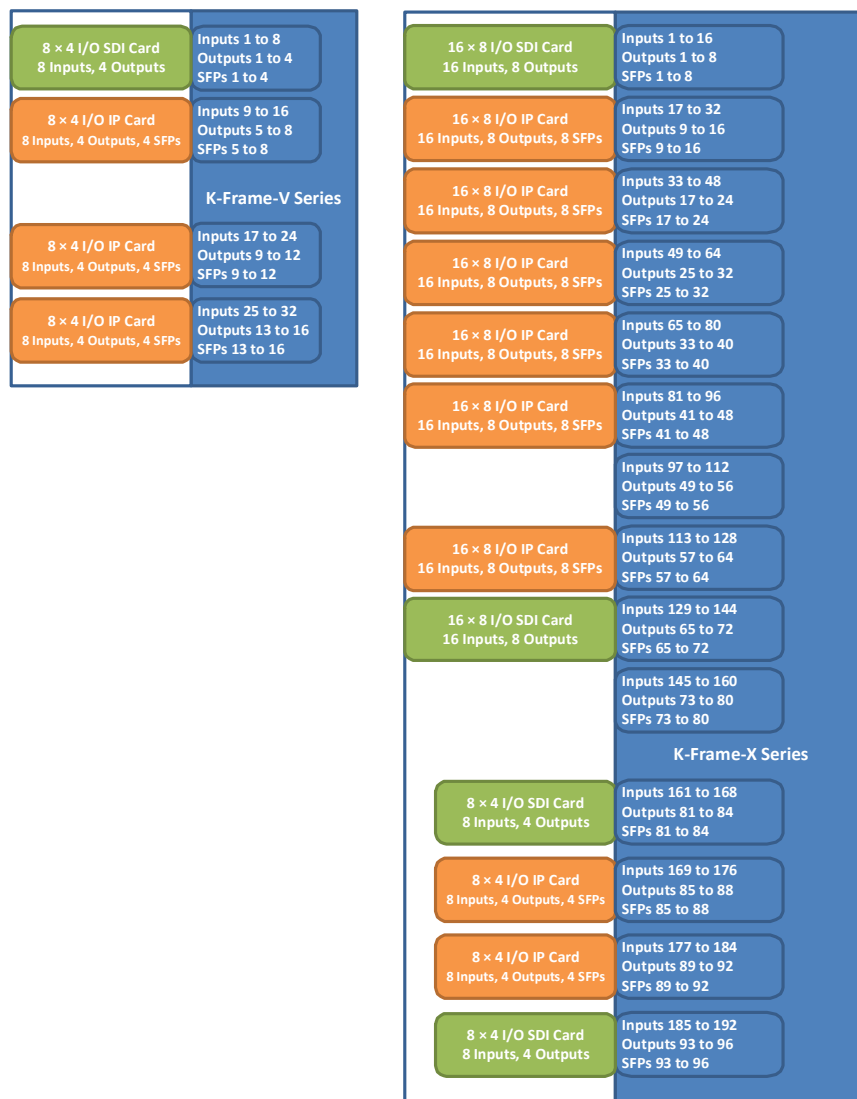

There are two types of modules which can be used in the K-Frame Production Switcher slots:

- SDI only card, equipped with BNC connectors.

- IP only card, equipped with SFP connectors.

Here are some details about IP cards you will need to know to model your K-Frame Production Switcher in GV Orbit Control:

- An SFP can receive two streams and transmit one. A stream is a group of the essence flows (a 2022-6 stream has a single flow, a TR-04 stream has two flows and a SMPTE 2110 stream has three flows)
- Each SFP stream maps directly to a switcher input or output of the slot. For example: the IP card in the second slot of the K-Frame-V Production Switcher has 4 SFP pairs (for redundancy) providing signals to inputs 9-16 of the switcher. The first SFP provides streams for inputs 9-10, the second SFP provides streams for inputs 11-12 and so on.
- IP cards support SMPTE 2022-6, SMPTE 2110, and TICO.
- Redundancy in SMPTE 2022 and SMPTE 2110 is supported.
- For SMPTE 2110-30, the following profiles are supported: L16/48K/125us, L16/48K/1ms, L24/48K/125us, L24/48K/1ms.

Note that GV Orbit Control only controls the K-Frame Production Switcher's IP receivers and transmitters. In consequence, The K-Frame Production Switcher must have been previously setup and configured before being integrated into GV Orbit Control. See the *K-Frame Installation & Service Manual* for more information.

PREREQUISITES: GV Orbit Control must have IP connectivity to the K-Frame Production Switcher:

- to automatically detect the K-Frame Production Switcher's model (K-Frame-V / K-Frame-X) and its current configuration parameters that are needed by GV Orbit Control.
- before making connections to the *Production Switcher* bubble in GV Orbit Control. See [To configure a K-Frame Production Switcher](#), on page 204.

K-Frame Production Switcher Nomenclature used in GV Orbit Control

The following diagram shows the nomenclature used in GV Orbit Control for the K-Frame-V Production Switcher signal flow. A K-Frame-X Production Switcher's signal flow uses a similar architecture, with more inputs and outputs.

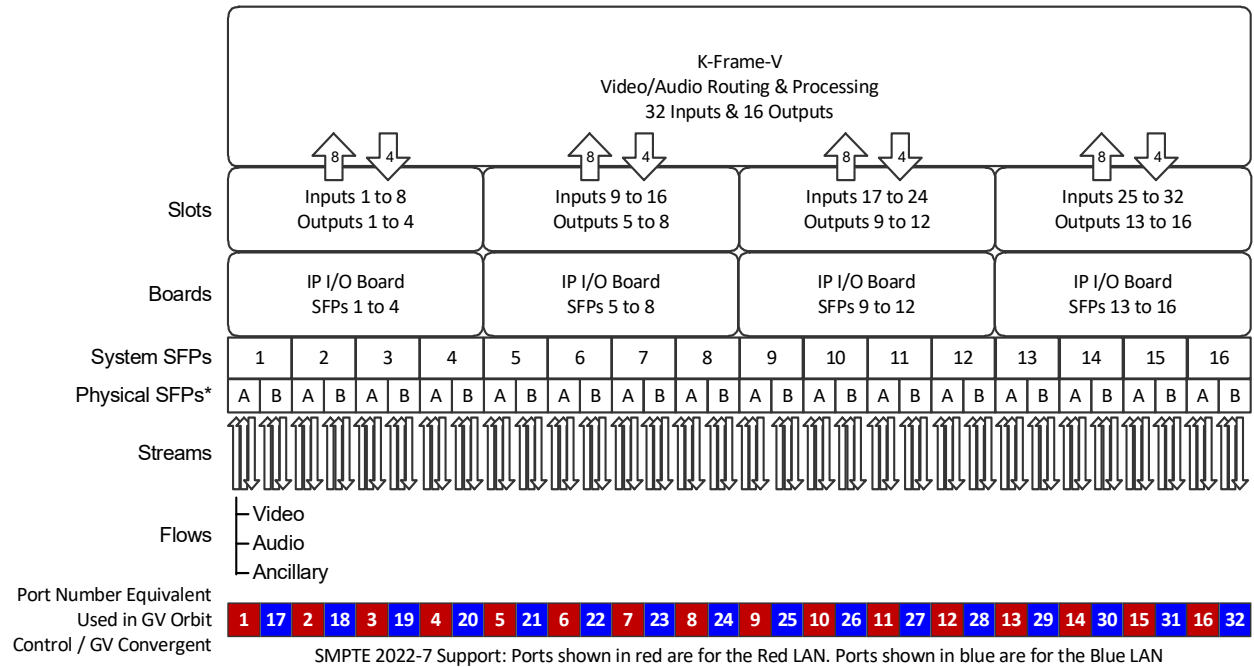

* This is shown in the Short Name property for a port. For example, SFP-1A is the first input port.

* Note that GV Orbit Control's **Short Name** property for a port is composed of a combination of the System SFP number and the Physical SFP letter in the following format:
 SFP-[System SFP number][Physical SFP letter]

For example, **SFP-1A** is the first input port. This port is shown below in the K-Frame Menu for reference.



When *Redundancy Mode* is *Enabled* in the K-Frame Menu, you must use a SMPTE ST 2022-7 network setup; see [Configuring Network Switch Redundancy to Support SMPTE ST 2022-7](#), on page 230.

To configure a K-Frame Production Switcher

- 1 Add the Production Switcher device to the Topology: from the **Device Library, Virtual Device**, find the **Production Switcher** device bubble. See [To add a Virtual Device to a topology](#), on page 44.

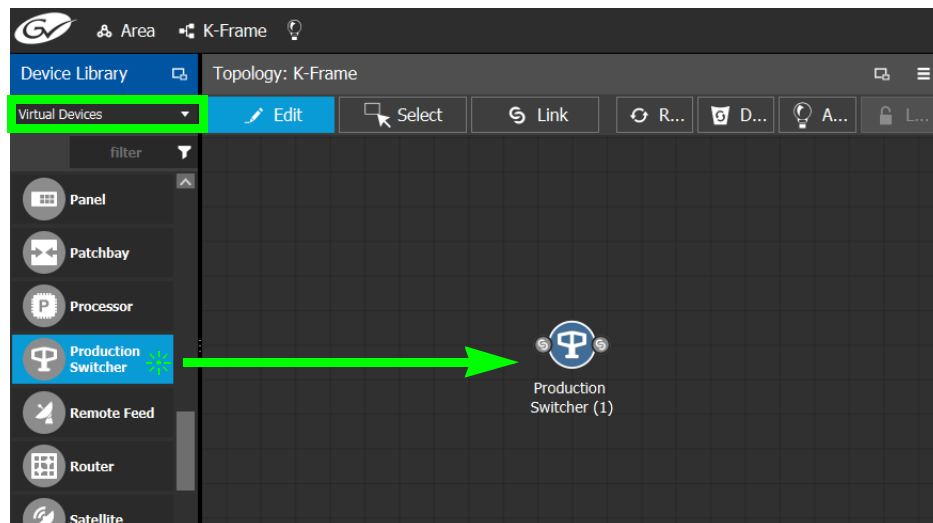

- 2 Click on the name of the device underneath the bubble to enter a meaningful name to identify this device in the **Name** field. See [To name a device and set the number of devices in the group](#), on page 45.

These parameters can also be set in the **Property Editor**.

- Click **New**  next to **Control Port** at the top of the **Property Editor** and select **K-Frame CPL TCP/IP** from the list. See also [Defining Device Properties](#), on page 61 for more information.

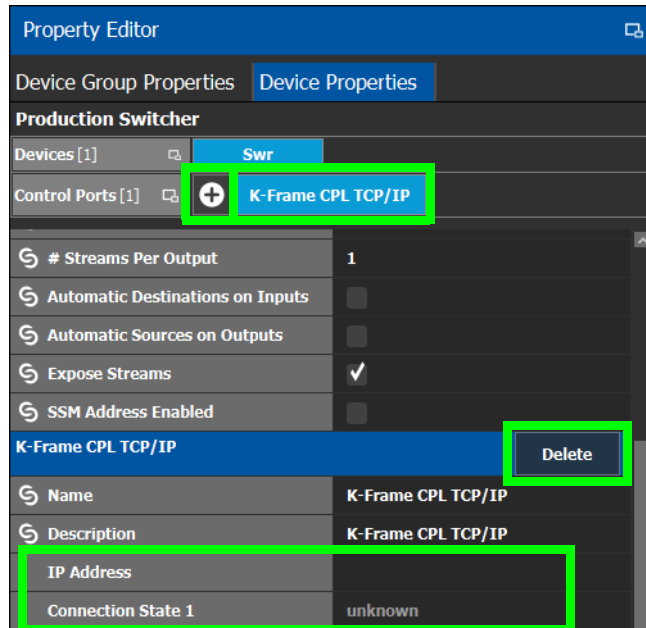

The **K-Frame CPL TCP/IP** tab appears. To remove the control port, click **Delete**.

- Configure the K-Frame Production Switcher properties. See also [Description of Common Device Properties](#), on page 162.

Parameter	Description
Network Host Name	The hostname is the unique name by which the associated K-Frame Production Switcher is known on the network.
IP Address	The IP address of the K-Frame Production Switcher to be controlled. Once connected, GV Orbit Control automatically detects the K-Frame Production Switcher's model (K-Frame-V / K-Frame-X) and K-Frame Production Switcher's configuration parameters that are needed by GV Orbit Control.

Parameter	Description
Connection State 1 Connection State 2	<p>K-Frame Production Switcher Connection State 1 shows the connection status of the K-Frame Production Switcher with the primary server of a server group.</p> <p>K-Frame Production Switcher Connection State 2 shows the connection status of the K-Frame Production Switcher with the secondary server of a server group. See Configuring a Controller Group, on page 19.</p> <p>unknown: The topology is inactive (see Activating a Topology, on page 66) or the K-Frame Production Switcher does not have network connectivity to the GV Orbit Server(s).</p> <p>Reconnecting: The topology has been activated and GV Orbit Control is learning the K-Frame Production Switcher's current configuration.</p> <p>offline: The K-Frame Production Switcher does not have network connectivity to the GV Orbit Server(s).</p> <p>online: The K-Frame Production Switcher is connected to the GV Orbit Server(s).</p>
Frame Model	Once the topology has been activated, this shows the frame model. This is shown for information purposes only.

5 Activate the topology. See [Activating a Topology](#), on page 66.

The current K-Frame Production Switcher input and output ports are read into GV Orbit Control and become available to be connected within GV Orbit Control. According to the type of streams configured in K-Frame Production Switcher, the corresponding logical levels are created in the Logical Device Table. See [Logical Device Table Tasks](#), on page 72 for more information.

When a port is selected, see the **Short Name** property to see the K-Frame Production Switcher’s internal port reference. For more information, see [K-Frame Production Switcher Nomenclature used in GV Convergent](#), on page 203.

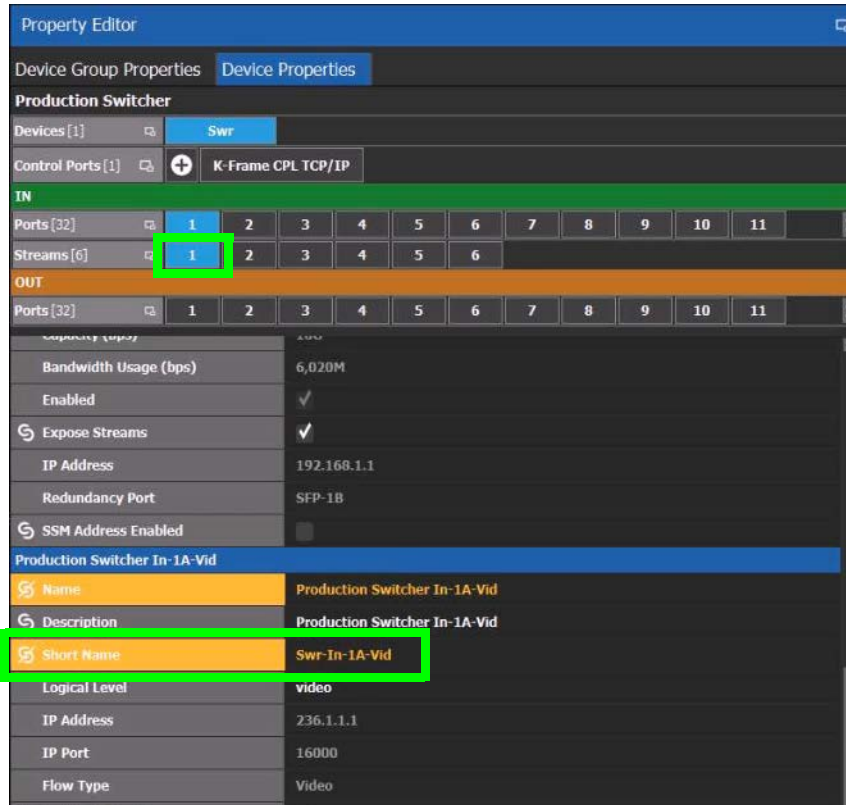

Each input port supports two sources. When a stream is selected, see the **Short Name** property to see the stream type currently configured in the K-Frame Production Switcher.

Streams	Description	Short Name
1	This is the video stream for the first source.	Swr-In-1A-Vid
2	This is the audio stream for the first source ^a .	Swr-In-1A-Aud
3	This is the Ancillary stream for the first source ^a .	Swr-In-1A-Anc
4	This is the video stream for the second source.	Swr-In-2A-Vid
5	This is the audio stream for the second source ^a .	Swr-In-1A-Aud
6	This is the Ancillary stream for the second source ^a .	Swr-In-1A-Anc

a. This stream is not shown if the selected port is configured as SMPTE 2022-6.

The K-Frame Production Switcher can now be used to make takes. See [Router Control Tasks](#), on page 289 for more information.

Adding NMOS Devices to a Topology

GV Orbit Control supports Networked Media Open Specifications (NMOS) AMWA IS-04 for device discovery and registration and IS-05 for connection management¹. Furthermore, it supports AMWA BCP-002-01 for the natural grouping of NMOS resources.

GV Orbit Control has a built-in NMOS registry (see below) that can be used to register NMOS devices. To be able to discover NMOS devices, you have one of the following options:

- Allow GV Orbit Control to automatically discover one or more NMOS registries through DNS-SD. DNS-SD can discover an NMOS registry that is available on the network and registered in your DNS server.
- Point GV Orbit Control to use its internal NMOS registry (when enabled), or to an external NMOS registry.

GV Orbit relies on the NMOS senders / receivers Group Hint Tag property to determine the available audio streams / flows to be used in order to extract the appropriate audio channels used for the creation of the automatic logical sources / destinations. You can still create custom logical sources / destinations using specific streams and specific audio channels.

PREREQUISITES:

- Entries for your NMOS registries have been added to the network DNS server. This enables automatic DNS-SD discovery. Contact your IT department to do so. Otherwise you can manually specify the registry to connect to.
- Routing between IP sources and IP destinations that have different flow configurations requires an Audio Live in order to convert audio flows into compatible ones. See [Configuring a Device that Supports Audio Breakaway/Shuffling such as Audio Live](#), on page 252.

Notes

- GV Orbit Control listens for changes to any of the nodes in the registry. As it receives updates, it automatically updates any device that is dropped onto any topology that is associated with that node.
 - If the registry is shut down, or the node is stopped and is removed from the registry, the devices will disappear from the list of discovered devices. The devices you already have dropped will remain on the topology, but will no longer receive updates.
 - If the registry is restarted or the node is restarted, GV Orbit Control will continue to update the devices on the topology (assuming the devices have the same UUID).
-

To configure GV Orbit Control for use with NMOS

To use GV Orbit Control with NMOS devices, you first must configure it to use its internal NMOS registry, to use an external NMOS registry, or to automatically search for external NMOS registries.

¹ GV Orbit Control supports IS-05 v1.1 API when available. This version is used before v1.0 when both versions are available.

- 1 Open the **System Controller Group Properties**. See [Configuring a Controller Group](#), on page 19.
- 2 Set the following parameters.

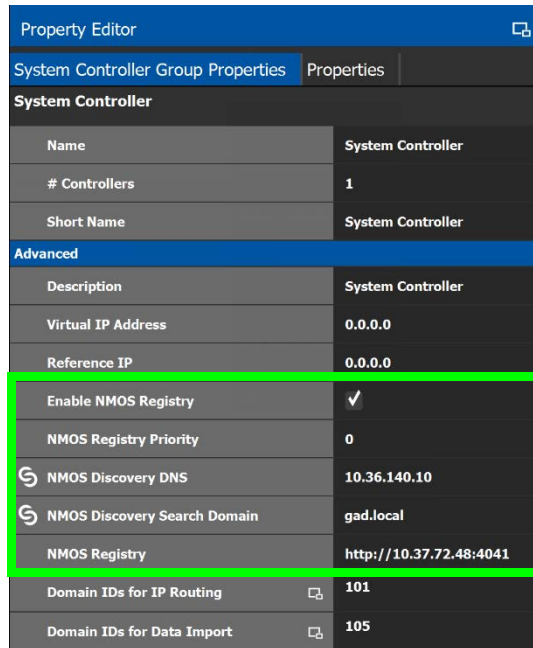

Parameter	Description
Enable NMOS Registry	Set to start the GV Orbit Control NMOS registry located on the GV Orbit Server.
NMOS Registry Priority	Sets the priority of GV Orbit Control's built-in registry that is started when the <i>Enable NMOS Registry</i> option is enabled. If GV Orbit Control's built-in registry is going to be the primary NMOS registry, set this value to 0 . Avoid having more than one registry on your network with the same priority level.
NMOS Discovery DNS	GV Orbit Control can automatically discover an NMOS registry through DNS-SD when the NMOS Discovery DNS and NMOS Discovery Search Domain parameters are set. NMOS Discovery DNS: The IP address of the network DNS server that is also used to support networked NMOS devices. NMOS Discovery Search Domain: The network's domain name on which GV Orbit Control will search for NMOS devices and the NMOS registry.
NMOS Discovery Search Domain	

Parameter	Description
NMOS Registry	<p>This shows the current NMOS Registry Query API URL (hostname / IP address and port number).</p> <p>Set a static NMOS registry URL when NMOS registry discovery is non-functional or when you want to override it to use a specific NMOS registry.</p> <p>If the above Enable NMOS Registry is enabled, and you want to use GV Orbit Control's built-in NMOS registry, set this URL to the local host IP address for this service: http://127.0.0.1:4041. The NMOS registry is available to NMOS devices at the current system controller's IP address^a, on port 4041.</p> <p>If redundancy has been configured for GV Orbit Control, use the Virtual IP Address, on port 4041 to access the NMOS registry.</p> <p>To revert to automatic NMOS registry discovery, clear this field, press <Enter>, and wait 10 seconds for the above NMOS Discovery DNS and NMOS Discovery Search Domain parameters to take effect.</p>

a. This is the same IP address as for GV Orbit's administration interface. This is shown as **IP Address** in [step 6](#) on page 22.

- 3 To be able to discover NMOS devices in GV Orbit Control, you have one of the following options:
 - Allow GV Orbit Control to automatically discover one or more NMOS registries through DNS-SD (set the **NMOS Discovery DNS** and **NMOS Discovery Search Domain** parameters). This is possible when the NMOS registries have been added to the network DNS server.
 - Manually point GV Orbit Control to use its internal NMOS registry (when enabled), or to an external NMOS registry by setting a fixed URL for the registry (set the **NMOS Registry** parameter).

Update the server's Host file

In order for GV Orbit Control to communicate with the NMOS registry to retrieve a list of all its resources, retrieve update notifications, download SDP files and perform connection management, GV Orbit Control must be able to reach the host where the registry is running by its hostname. In order to do this, an entry for the NMOS host **MUST** be added to the server's hosts file.

The Host file is found here: `/etc/hosts`

Sample entry:

```
10.37.80.177 <registryHostName>
```

Once the server for the NMOS registry has been added to the hosts file, the GV Orbit Control service needs to be restarted. See *GV Orbit Server Shutdown and Reboot* in the **GV Orbit Control Quick Tour of Admin Tasks** See [Related Documentation](#), on page 7.

Note that this applies even if you use the registry's IP address when specifying the URL of the NMOS Discovery Registry. Once the entry in the hosts file is added, the **NMOS Registry** parameter can be either `http://10.37.80.177:4041` or `http://<registryHostName>:4041`

To update the server's Host file, contact Grass Valley Technical Support. See [Grass Valley Technical Support](#), on page 845.

NMOS Node control port status in GV Orbit Control

GV Orbit Control pings the NMOS node to keep the connection active using the URL `http://XXX.XXX.XXX.XXX:4041/x-nmos/node/v1.2/self`. GV Orbit Control uses the success of the ping to determine the node's control port status (Online/Offline).

Note: If the NMOS node's status is offline, check if the node's URL contains only a hostname (as opposed to a numeric IP address). If GV Orbit Control cannot resolve the hostname, then you need to add an entry into the server's hosts file and then restart GV Orbit Control. GV Orbit Control must be able to resolve the node's hostname in order to report the control port status as being online, download SDP files, and perform connection management. See [Update the server's Host file](#), on page 210 and *GV Orbit Server Shutdown and Reboot* in the **GV Orbit Control Quick Tour of Admin Tasks** See [Related Documentation](#), on page 7.

How to test the NMOS registry

Test the registry as follows: in a web browser, enter the following address into the browser's address bar: `http://XXX.XXX.XXX.XXX:4041/x-nmos/query/v1.2/`

Where `XXX.XXX.XXX.XXX` is the IP address of GV Orbit's NMOS registry. This can be either GV Orbit's Server IP address (for its internal NMOS registry), or the query API IP address of an external NMOS registry, if available. For external NMOS registries, see the NMOS registry's documentation as it may use a number of different IP addresses; one for the query API and another for the registration API for example.

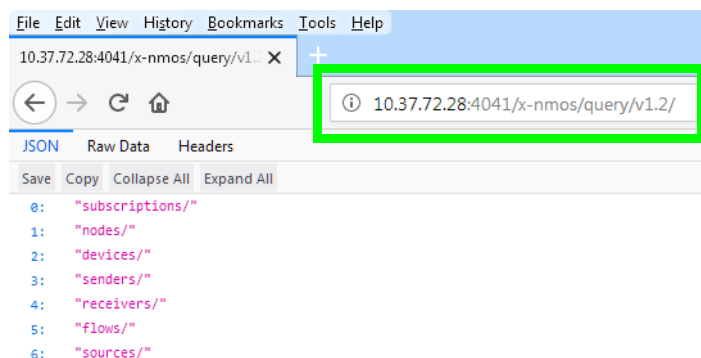

The following NMOS registry switches show the current NMOS registry's content:

- subscriptions
- nodes
- devices
- senders
- receivers
- flows
- sources

This is accessible by, for example, entering the following address into the browser's address bar: `http://XXX.XXX.XXX.XXX:4041/x-nmos/query/v1.2/nodes`

As the NMOS registry has just been started, it is normal that it is empty of content. Wait for devices to discover the NMOS registry and to publish their resources to the registry.

Note: If nodes are not published to the registry and are not listed under `http://XXX.XXX.XXX.XXX:4041/x-nmos/query/v1.2/nodes`, they will not be discovered by GV Orbit Control. Further device troubleshooting will be required to identify why a device is not publishing to the NMOS registry.

About the grouphint tag

AMWA BCP-002-01 makes use of the *grouphint* tags to identify senders and receivers. When a discovered device publishes grouphint tag information in senders / receivers to the NMOS registry, GV Orbit Control will automatically create the related logical sources and destinations for the device, once the NMOS device has been added to the topology. If a discovered device does not publish grouphint tags to the NMOS registry, then you will have to create the logical sources and destinations for the device manually in GV Orbit Control.

Logical sources / destinations are created using the audio channels from the grouphint tag information, when available. GV Orbit assesses if the audio flows use 1, 2 or 4 audio streams and then the 16 audio channels from the automatic logical sources / destinations are accordingly created using the multi audio streams / flows as required.

Number of Audio Flows as determined by the flow's grouphint tag	Effect in GV Orbit Control
1	<p>There is 1 audio stream with 16 audio channels which are represented in GV Orbit Control by the AES67-16 logical level. In the NMOS device's Properties, the following streams are available:</p> <p>1: SDI, SMPTE ST 2022. In the Logical Device Table, this is represented by the SDI column.</p> <p>2: Video, SMPTE ST 2110-20. In the Logical Device Table, this is represented by the V column.</p> <p>3: Audio AES67-16, SMPTE ST 2110-30. In the Logical Device Table, this is represented by the A1 to A16 columns.</p> <p>7: Ancillary, SMPTE ST 2110-40. In the Logical Device Table, this is represented by the ANC column.</p>

Number of Audio Flows as determined by the flow's grouphint tag	Effect in GV Orbit Control
2	<p>There are 2 audio streams; each stream has 8 audio channels which are represented in GV Orbit Control by the AES67-8 logical level. In the NMOS device's Properties, the following streams are available:</p> <p>1: SDI, SMPTE ST 2022. In the Logical Device Table, this is represented by the SDI column.</p> <p>2: Video, SMPTE ST 2110-20. In the Logical Device Table, this is represented by the V column.</p> <p>3: Audio AES67-8, SMPTE ST 2110-30. In the Logical Device Table, this is represented by the A1 to A8 columns.</p> <p>4: Audio AES67-8, SMPTE ST 2110-30. In the Logical Device Table, this is represented by the A9 to A16 columns.</p> <p>7: Ancillary, SMPTE ST 2110-40. In the Logical Device Table, this is represented by the ANC column.</p>
4	<p>There are 4 audio streams; each stream has 4 audio channels which are represented in GV Orbit Control by the AES67-4 logical level. In the NMOS device's Properties, the following streams are available:</p> <p>1: SDI, SMPTE ST 2022. In the Logical Device Table, this is represented by the SDI column.</p> <p>2: Video, SMPTE ST 2110-20. In the Logical Device Table, this is represented by the V column.</p> <p>3: Audio AES67-4, SMPTE ST 2110-30. In the Logical Device Table, this is represented by the A1 to A4 columns.</p> <p>4: Audio AES67-4, SMPTE ST 2110-30. In the Logical Device Table, this is represented by the A5 to A8 columns.</p> <p>5: Audio AES67-4, SMPTE ST 2110-30. In the Logical Device Table, this is represented by the A9 to A12 columns.</p> <p>6: Audio AES67-4, SMPTE ST 2110-30. In the Logical Device Table, this is represented by the A13 to A16 columns.</p> <p>7: Ancillary, SMPTE ST 2110-40. In the Logical Device Table, this is represented by the ANC column.</p>

In the NMOS device Properties, the number, type of streams, and AES67 Logical Level are updated in real time according to the grouphint tag information. For example, this screen shows the Properties for an NMOS device where there is 1 audio stream, and as a consequence, the level for the audio stream is shown as AES67-16.

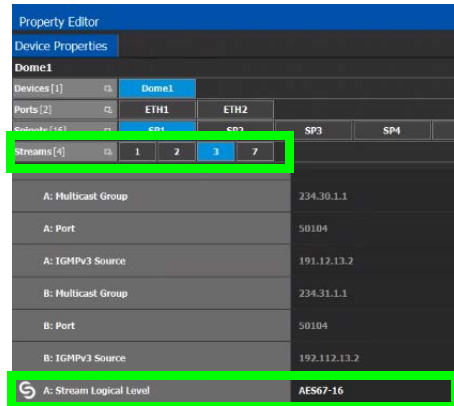

In the Logical Device Table, the NMOS device reflects the automatic.

To Add an NMOS Device to a Topology

PREREQUISITES:

- There is an operational NMOS registry on the network.
- GV Orbit Control has been configured to connect to the NMOS registry. See [To configure GV Convergent for use with NMOS](#), on page 208.
- NMOS devices must be configured to publish their available resources to the NMOS registry.

Proceed as follows.

- 1 Add the NMOS device to the Topology: from the **Device Library, Discovered**, find an NMOS device bubble that you want to control. See [To add a Discovered Device to a Topology](#), on page 48.

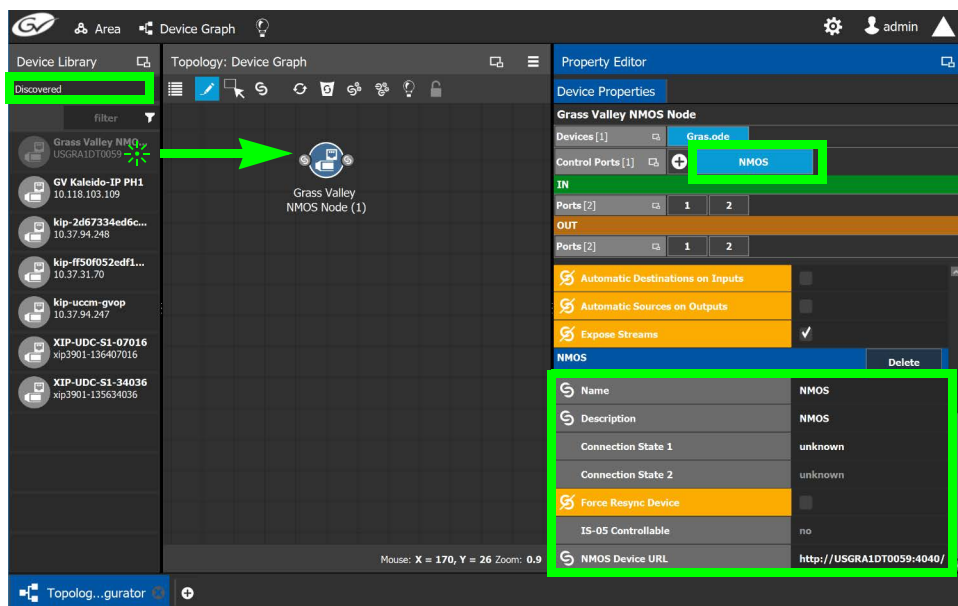

- 2 Click on the name of the device underneath the bubble to name the device or device group. See [To name a device and set the number of devices in the group](#), on page 45.

- 3 The NMOS Control Port parameters are configured in the device's Property Editor, under the **Device Properties** tab. See [Defining Device Properties](#), on page 61 for more information about this tab.
- 4 Select **NMOS** tab (next to **Control Port** at the top of the **Property Editor**) to configure the Device Properties in the **Property Editor**. See also [Description of Common Device Properties](#), on page 162.
The NMOS control port properties appear.

Parameter	Description
Connection State 1 / 2	This shows the current connection state to the NMOS nodes. When a redundant configuration is used (two GV Orbit Servers form a cluster) Connection State 1 and Connection State 2 shows the connectivity of each server to the NMOS nodes. unknown: The topology is inactive (see Activating a Topology , on page 66) or the NMOS device does not have network connectivity to the GV Orbit Server(s). reconnecting: The GV Orbit Server is in the process of establishing communications with the NMOS device. offline: The NMOS device does not have network connectivity to the GV Orbit Server(s). online: The NMOS device is connected to the GV Orbit Server(s).
Force Resync Device	Set to make GV Orbit Control reload the NMOS device's parameters from the NMOS registry.
IS-05 Controllable	This status shows whether the corresponding node in the NMOS registry has devices that support being controlled through IS-05 (connection management). Yes: Routes to these devices should succeed. No: If you try to route to a device that is not IS-05 controllable, the route will fail. Partial: Some devices are controllable in this node, while others are not.
NMOS Device URL	This is the NMOS device's current URL and port number.

Ports and streams are automatically created using the values found in the registry, and they will automatically be updated whenever GV Orbit Control receives notifications of changes from the NMOS registry.

You can change the following NMOS device properties which will not be overwritten with values from the NMOS registry (the value you set for these properties will persist in GV Orbit Control): Labels, Short labels, Descriptions, Network label, and Logical levels. See [Defining Device Properties](#), on page 61.

Using SDP Parameters to Take a Stream from a non-NMOS Device to an NMOS Device

In order to use IS-05 connection management, Session Description Protocol (SDP) information is required to be sent as part of the command. GV Orbit Control can create SDP type parameters that a receiving NMOS device requires in order to successfully complete a take made from devices that do not generate and publish their own information.

The SDP information is now generated by GV Orbit Control and is included in the connection management commands to allow discovered AMWA NMOS receivers to join non-discovered senders, or source devices created within the GV Orbit Control client. This SDP information is not currently published to the AMWA NMOS registry.

Within GV Orbit Control, a number of default SDP parameter templates are built-in and are selected according to the stream's **Logical Level** parameter. The SDP parameters can be tweaked if necessary as these SDP parameters must represent the current details and specifications of the source's stream.

The following device bubbles support SDP parameters:

- IP Device
- GV Node
- IQ-family type IP devices, for example, IQMix, IQUCP, UCP-3901, IQAMD, MV-820-IP, Kahuna IP, and so on
- Audio Live

Related Topics

- The Stream Configurator allows you to configure the SDP template for streams on a large scale. See [Stream Configurator Tasks](#), on page 152.

PREREQUISITES: To customize the SDP parameter, you must know how to form a valid SDP. This is beyond the scope of this document. For more information about SDP specific parameters, see [RFC 4566](#). See also [SDP](#).

The SDP parameters are configured in the device's Property Editor, under the **Device Group Properties** tab and in the **Device Properties** tab. See [Defining Device Properties](#), on page 61 for more information about these tabs.

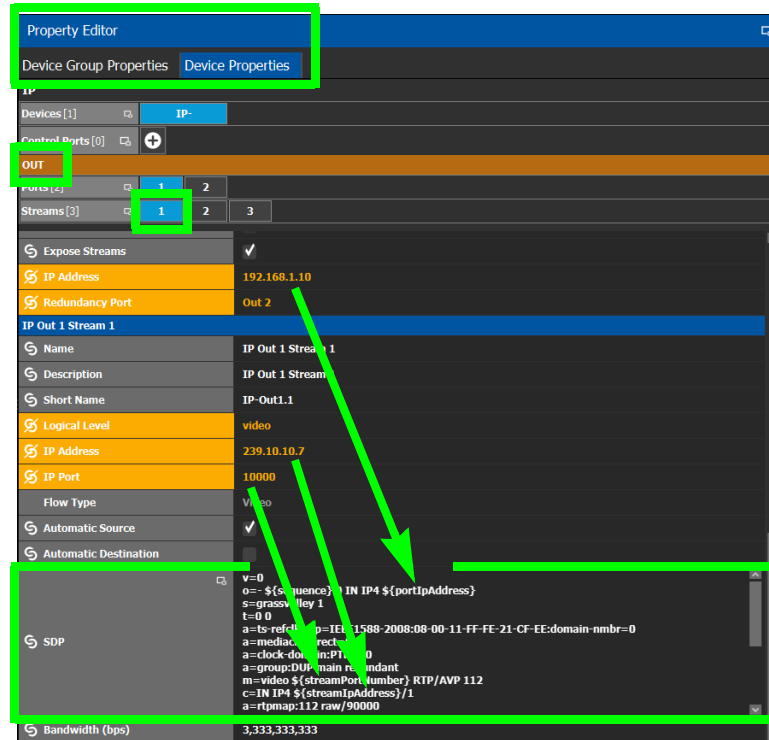

Certain SDP parameters have been enhanced with new GV Orbit Control variables which allows for better device control integration within GV Orbit Control. These variables are available for **SDP** parameters configured under the **Device Group Properties** and the **Device Properties** tab, output stream property. Variables always start with a dollar sign (\$) and are enclosed in curly brackets {} as shown in the example below.

Once the topology is activated, the variables set in the SDP are replaced with the actual values GV Orbit Control has resolved for the device's stream. This can be helpful for troubleshooting.

See [Defining Device Properties](#), on page 61 to know more about how parameter values in the **Device Properties** tab inherit their values from the corresponding parameter values in the **Device Group Properties** tab.

Example of SDP parameters used in GV Orbit Control

The following is a typical example of the SDP parameters used in GV Orbit Control.

```
v=0
o=- ${sequence} 0 IN IP4 ${portIpAddress}
s=grassvalley 1
t=0 0
a=recvonly
a=ts-refclk:ptp=IEEE1588-2008:08-00-11-FF-FE-22-04-00:127
a=mediaclk:direct
m=video ${streamPortNumber} RTP/AVP 98
```

```
c=IN IP4 ${streamIpAddress}/1
a=rtpmap:98 SMPTE2022-6/27000000
```

Special GV Orbit Control SDP Variables

The following table lists the supported special GV Orbit Control variables for use anywhere within the SDP parameter. These variables reference parameters that are configured elsewhere in GV Orbit Control, thereby automatically keeping stream information up-to-date.

GV Orbit Control SDP Variable	Description
<code>\${audioBits}</code>	The audio stream's bit depth.
<code>\${channelCount}</code>	The number of (audio) channels.
<code>\${clockSetting}</code>	The PTP master clock setting.
<code>\${sequence}</code>	This SDP file's ID
<code>\${packetTime}</code>	The length of time in milliseconds represented by the (audio) media in a packet.
<code>\${portIpAddress}</code>	The sending port's IP address. The source for this variable comes from the Port's IP Address parameter for this stream.
<code>\${streamIpAddress}</code>	The transmit (sending) stream's multicast IP address. The source for this variable comes from the stream's IP Address parameter.
<code>\${streamPortNumber}</code>	The transmit (sending) stream's IP port number. The source for this variable comes from the stream's IP Port parameter.
<code>\${redundantIpAddress}</code>	The transmit (sending) stream's redundant multicast IP address. The source for this variable comes from the stream's IP Address parameter used for the redundancy port. See the Redundancy Port parameter to identify the current redundancy port.
<code>\${redundantPortNumber}</code>	The transmit (sending) stream's redundant IP port number. The source for this variable comes from the stream's IP Port parameter used for the redundancy port. See the Redundancy Port parameter to identify the current redundancy port.
<code>\${redundantPortIpAddress}</code>	The transmit (sending) stream's redundant IP port number. The source for this variable comes from the stream's IP Address parameter used for the redundancy port. See the Redundancy Port parameter to identify the current redundancy port.
<code>\${rtpPayloadType}</code>	The RTP payload type as defined by the SDP specification.
<code>\${samplingRate}</code>	The audio stream's sampling rate.

Editing SDP Parameters

Any of the above variables can be substituted with a fixed equivalent value so that it is hard coded. For example, the variable `${portIpAddress}` represents a multicast IP address and it can be replaced with an IP address such as `230.1.1.1`.

When you edit any SDP parameter:

- The SDP becomes fixed and will no longer automatically update when you make a change elsewhere in the Property Editor. For example, changing the logical level parameter will not update the SDP parameters with the logical level change. You will have to further edit the SDP to adapt it to any such change.
- The SDP becomes orange to indicate that its default value has been overridden. See [Defining Device Properties](#), on page 61 to know more about how to reset a parameter to its default value.

Configuring Cisco DCNM Network Switch Devices

Networks that use Cisco Data Center Network Manager (DCNM) to manage LAN fabric can be controlled by GV Orbit Control.

PREREQUISITES:

- GV Orbit Control v1.8 or higher
- DCNM build 11.0(1) or higher
- Switch's firmware: NXOS 9.2(1) or higher for 9200, 9300-EX, and 9500-R switches.
- Switch's BIOS: version 07.64, compile time: 05/17/2018
- Configure the required DCNM network switch's flow policies. See below.

Note: As of DCNM v11.5(1), the DCNM application is now separate from the RabbitMQ application, with each application having its own independent user credential management. Thus, changing DCNM user credentials will not change existing RabbitMQ user credentials. Note that GV Orbit Control uses the user credentials from RabbitMQ and not from DCNM.

Configuring the Network Switch's Flow Policies

If you are using a network switch with DCNM control port, flow policies must be manually set in the DCNM web interface, before you configure GV Orbit Control to use the network switch.

Each flow policy sets the maximum bandwidth that can be allocated to a type of traffic flow. See the table below. **Only the flow policies for bandwidths you will use in your network need to be created.**

Each flow policy must have a multicast IP address range associated to it, according to your network addressing pattern, as GV Orbit Control uses a different multicast IP range for each type of traffic flow and bandwidth (audio, video 3G, Video HD, ANC / metadata, and so on). Class D IP addresses are multicast addresses. By default, IP address 239.255.0.1 may be reserved for use by certain Grass Valley equipment for DDS discovery and should not be allocated for any other purpose.

Review documentation for all equipment you are going to use on your network for any specific IP addressing and bandwidth requirements.

Establish the Customer Multicast IP Addressing Pattern

All network IP devices must be assigned an IP address, and each network traffic type is assigned to a IP address range according to its bandwidth requirement.

For example, the following table shows a typical multicast IP addressing pattern and the bandwidth allocation required by traffic flow type.

Traffic Flow Type	Flow Policy	Typical IP address range		Recommended Bandwidth Allocation
		From	To	
Video	SMPTE2022-6(3G)	230.1.1.1	230.255.255.255	3.2Gbps
	SMPTE2022-6(HD)	229.1.1.1	229.255.255.255	1.601Gbps
	SMPTE2022-6(SD)	228.1.1.1	228.255.255.255	0.27Gbps
	SMPTE2110-20(3G)	238.1.1.1	238.255.255.255	2.703Gbps
	SMPTE2110-20(HD)	237.1.1.1	237.255.255.255	1.401Gbps
	SMPTE2110-20(SD)	236.1.1.1	236.255.255.255	0.23Gbps
Audio	SMPTE2110-30(AES)	234.1.1.1	234.255.255.255	61Mbps
ANC (metadata)	SMPTE2110-40(ANC)	235.1.1.1	235.255.255.255	2Mbps
Default ^a		*		150Kbps

a. This allows any general network management data to pass through the network while guaranteeing that it will not take up any significant amount of total network bandwidth. When needed, this bandwidth allocation is also used for DDS discovery when such equipment uses a multicast address that is outside of any other pre-existing flow policy you have created (this must be the case).

Delete Pre-existing Flow Policies

If your switch has been previously configured, you may need to remove any pre-existing flow policies. These flow policies have the status **Create** under **Deployment Action**.

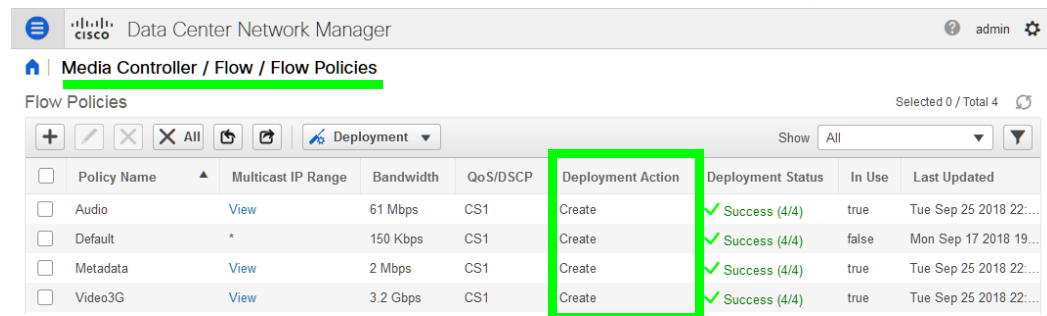

To delete pre-existing current flow policies

- 1 In the **Deployment** drop menu, select **Undeploy All Custom Policies**.

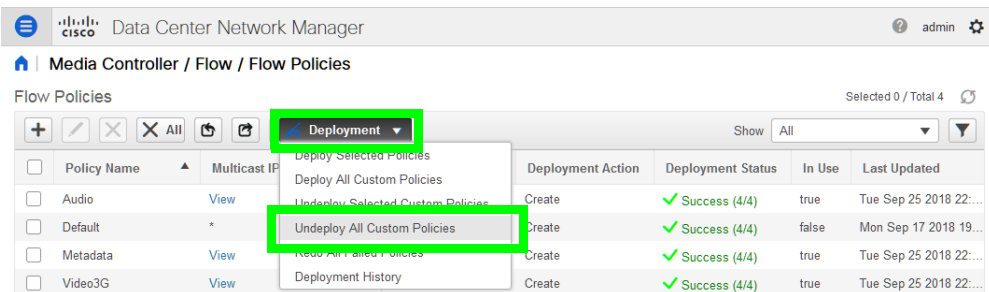

- 2 The **Deployment Action** column will show **Delete** instead of **Create**.
- 3 Select all flow policies from the list, but exclude the **Default** flow policy: do not remove the **Default** flow policy as it will be needed.
- 4 Use the delete (X) button to delete the selected flow policies.

Add New Flow Policies Using Your IP Addressing Pattern

According to the IP addressing pattern shown in the above table, create the new flow policies for each traffic flow type you are going to use.

To add new flow policies

- 1 Click New (+).

	Begin IP Address	End IP Address
<input type="checkbox"/>	239.0.0.0	239.255.0.0
<input type="checkbox"/>	239.255.0.2	239.255.255.255

- 2 Set the parameters for the flow policy. The setting for **QoS/DSCP** is **CS1**.
- 3 Click **Deploy**.
- 4 Repeat to create all necessary flow policies.
- 5 In the **Deployment** drop menu, select **Deploy All Custom Policies**.

The status under **Deployment Action** becomes **Create** and the **Deployment Status** becomes **Success**.

Media Controller / Flow / Flow Policies

Flow Policies

	Policy Name	Multicast IP Range	Bandwidth	QoS/DSCP	Deployment Action
<input type="checkbox"/>	Default	*	150 Kbps	CS1	Create
<input type="checkbox"/>	Audio	View	61 Mbps	CS1	Create
<input type="checkbox"/>	Metadata	View	2 Mbps	CS1	Create
<input type="checkbox"/>	Video_3G	View	3.2 Gbps	CS1	Create
<input type="checkbox"/>	DDS_discovery	View	150 Kbps	CS1	Create

Configuring a DCNM Network Switch Device

To configure a DCNM Network Switch Device

- 1 Add the Network Switch device to the Topology: from the **Device Library, Virtual Device**, find the Network Switch device bubble. See [To add a Virtual Device to a topology](#), on page 44.

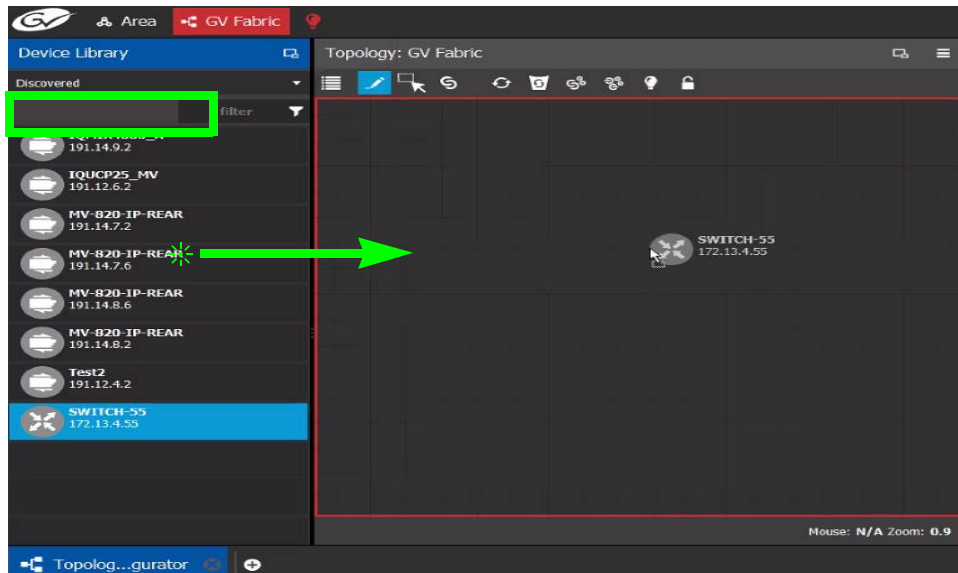

- 2 Click on the name of the device underneath the bubble to enter a meaningful name to identify this device in the **Name** field. See [To name a device and set the number of devices in the group](#), on page 45.

These parameters can also be set in the **Property Editor**.

- 3 Set the number of physical input and output connectors being used on the network switch in **# Input Connectors** and **# Output Connectors**. See [Defining Device Properties](#), on page 61 for more information.

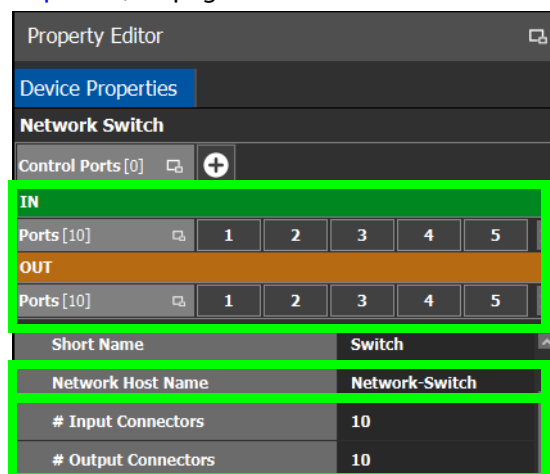

The configuration for these ports become available as **Ports** under **IN** and **OUT**.

- 4 Click **New**  next to **Control Ports** at the top of the **Property Editor** and select **Cisco DCNM** from the list. **Dummy Network Switch** should be used when the DCNM network

manager is not being used for the network switch. See [Defining Device Properties](#), on page 61 for more information.

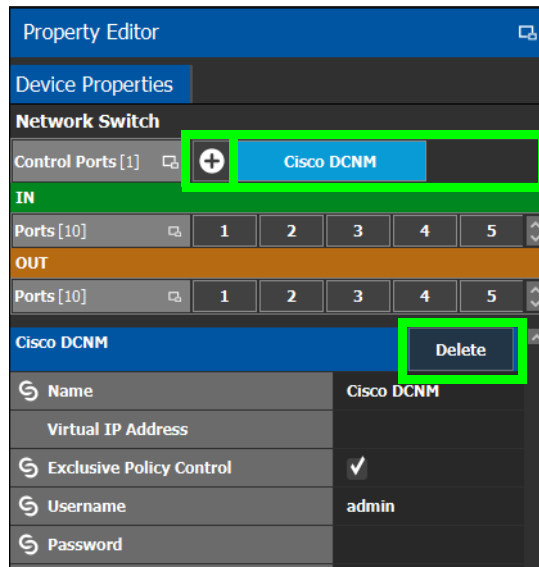

The **Cisco DCNM** tab appears. To remove the control port, click Delete.

- 5 Select **Cisco DCNM** tab (next to **Control Port** at the top of the **Property Editor**) to configure the Device Properties in the **Property Editor**. Only the properties shown below should be used. See also [Description of Common Device Properties](#), on page 162.

Parameter	Description
Network Host Name	This is the unique name by which the Network Switch is identified within GV Orbit Control. This value is used to construct the input/output port labels.
Cisco DCNM Control Port parameters	
Virtual IP Address	This is the virtual IP address to communicate with DCNM cluster. This IP is used to address any active member of the two nodes that are operating in High Availability (HA) mode. If DCNM is not operating in HA mode, use the DCNM node IP address.
Exclusive Policy Control	When set, GV Orbit Control operates in exclusive mode: any change to the host aliases, host policies or flow policies (through DCNM web interface for example) will be overwritten and restored by GV Orbit Control. This is the supported mode to be used. Only deselect this parameter under the guidance of Grass Valley Technical Support.
Enabled	When set, GV Orbit Control controls the switch. When deselected, GV Orbit Control no longer controls the switch, thus allowing you to perform maintenance operations on the switch. When re-establishing control (set Enabled), GV Orbit Control will push the current policies to the switch.
Username	Set the administrator's username to access the DCNM network.
Password	Set the administrator's password to access the DCNM network.

Parameter	Description
Connection State 1 / 2	This shows the current connection state to the switch. When a redundant configuration is used (two GV Orbit Servers form a cluster) Connection State 1 and Connection State 2 shows the connectivity of each server to the switches. Unknown: The Virtual IP is not configured yet or the topology is inactive. Online: GV Orbit Control is connected to DCNM. Offline: The topology is active and GV Orbit Control is unable to communicate with DCNM. Reconnecting: GV Orbit Control is trying to reach DCNM.
Active Host Name	In a redundant High Availability network architecture, one node (in standby mode) provides failover protection to another node (currently active). Host Name: The hostname is the unique name by which the active / standby node is known on the network. IP Address: The network IP address for the active / standby node.
Active IP Address	
Standby Host Name	
Standby IP Address	

- 6 Do not configure any parameters found under Ports or Streams. These are shown for information purposes only.
- 7 Add IP devices to the topology and then connect them to the switch: Click Quick Connect to link the devices. See [Using Quick Connect to Link all Devices in a Topology](#), on page 53. See also [Methods to Link Devices in a Topology](#), on page 53.

To support network redundancy for use with SMPTE ST 2022-7 compatible equipment, see [Configuring Network Switch Redundancy to Support SMPTE ST 2022-7](#), on page 230.

Use the Path Manager to view and troubleshoot the flow of streams through the switch fabric. See [Path Manager Tasks](#), on page 270.

Direct Flow Orchestration: How To Create a Static Flow with a Cisco Network Switch

This topic describes the use case where a destination IP device does not have an API exposed that allows GV Orbit Control to direct the device's receivers to join send streams. Or you want to control what is to be sent to an IP destination. For this, GV Orbit Control can control the egress ports of a network switch to statically stitch flows feeding the IP device. It is also necessary to remove the network interface ports from the available resources for dynamically stitching flows via IGMP joins. Another way of stating this, it is necessary to remove these paths from the available tielines.

To create a static flow with GV Orbit Control you need to set some information on an output port of a network switch with a DCNM control port.

- 1 For this procedure the following topology will be used. See [Adding Devices to a Topology](#), on page 44.



- 2 In the Network Switch's **Property Editor**, under **Control Ports**, select an output port on your network switch (for example, **Cisco DCNM**). This port should not be connected to anything. See [Configuring Cisco DCNM Network Switch Devices](#), on page 220.
- 3 Set the number of streams you need in **#Output Connectors**.
- 4 With the **Cisco DCNM** control port selected, set **Expose Streams**.
- 5 Set the name and IP address of the network switch's control port (**Cisco DCNM**). You find this information through the Inventory page on the DCNM web UI. (*Inventory, Switches, Select a leaf, Interfaces* tab). You have to add 1 to the last number of the IP. For example: 192.102.45.0/31 becomes 192.102.45.1.
- 6 On the port's streams, set the **Logical Level**. See [Configuring the Logical Levels for the Devices in a Topology](#), on page 37.
- 7 On the port's streams, set **Automatic Destination** if you do not want to create a logical destination yourself.
- 8 To create the static flow, you need to do a normal take from the streams (or logical destination if you created one) to the source you want.
- 9 To confirm if the flow is passing, you can check the flow status page on the DCNM UI (*Media Controller, Flow status*). Note: If the static flow was created but the source does not have a signal, there will be no feedback.

To delete a static flow, you need to do a take from the destination to a source with an IP of 0.0.0.0 on the streams.

GV Orbit ControlGV Orbit ControlGV Fabric is an IP switch enabling format agnostic signal routing for small to enterprise-wide installations.

To configure a GV Fabric Network Switch Device

- 1 Add the Network Switch device to the Topology: from the **Device Library, Virtual Device** find the Network Switch device bubble. See [To add a Discovered Device to a Topology](#), on page 48.

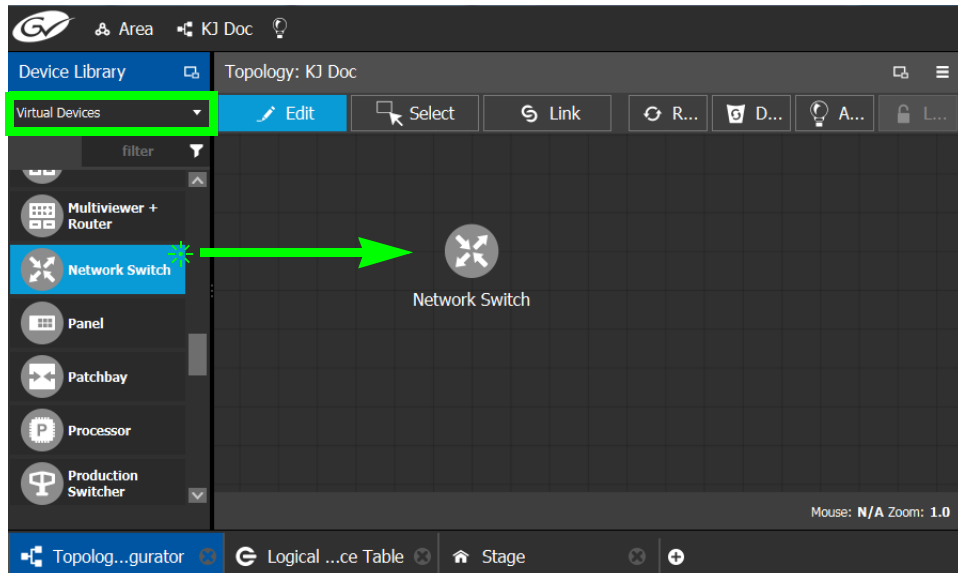

- 2 Click on the name of the device underneath the bubble to enter a meaningful name to identify this device in the **Name** field. See [To name a device and set the number of devices in the group](#), on page 45.

These parameters can also be set in the **Property Editor**.

- 3 Set the number of physical input and output connectors being used on the network switch in **# Input Connectors** and **# Output Connectors**. See [Defining Device Properties](#), on page 61 for more information.

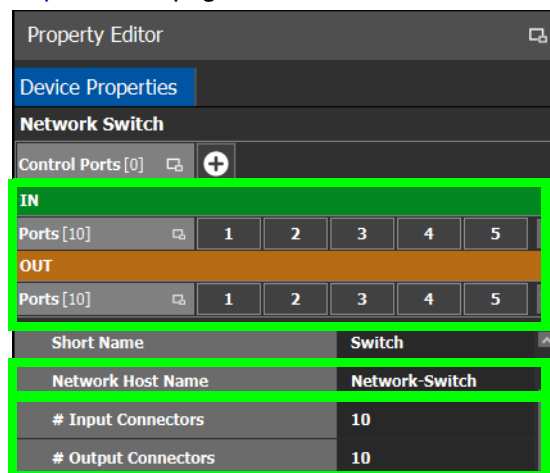

The configuration for these ports become available as **Ports** under **IN** and **OUT**.

- 4 Select **Device Properties** and click **New**  next to **Control Ports** at the top of the **Property Editor** and select **GV Fabric** from the list. See [Defining Device Properties](#), on page 61 for more information.

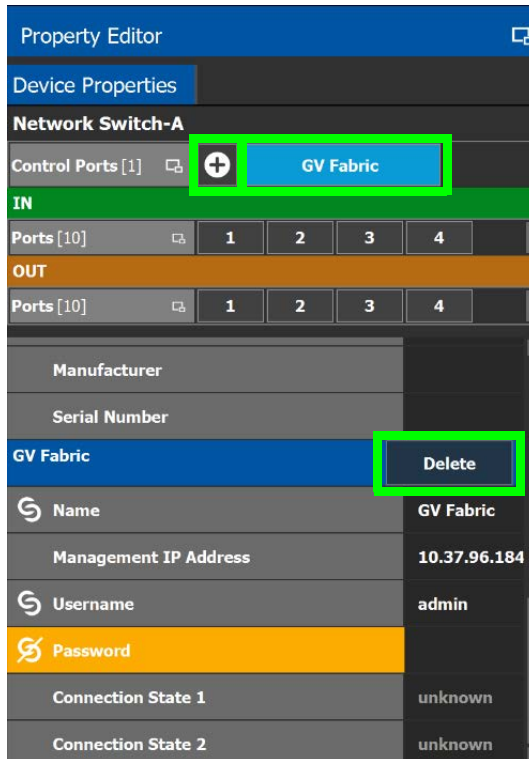

The **GV Fabric** tab appears. To remove the control port, click Delete.

- 5 Select **GV Fabric** tab (next to **Control Port** at the top of the **Property Editor**) to configure the Device Properties in the **Property Editor**. Only the properties shown below should be used. See also [Description of Common Device Properties](#), on page 162.

Parameter	Description
Network Host Name	This the unique name by which the Network Switch is identified within GV Orbit Control. This value is used to construct the input/output port labels.
GV Fabric Control Port parameters	
Name	Once GV Orbit Control connects to the switch, the switch's name is read from the switch's configuration.
Management IP Address	This is the switch's management IP address.
Username	Set the administrator's username to access the DCNM network.

Parameter	Description
Password	Set the administrator's password to access the DCNM network.
Connection State 1 / 2	This shows the current connection state to the switch. When a redundant configuration is used (two GV Orbit Servers form a cluster) Connection State 1 and Connection State 2 shows the connectivity of each server to the switches. Unknown: The Virtual IP is not configured yet or the topology is inactive. Online: GV Orbit Control is connected to DCNM. Offline: The topology is active and GV Orbit Control is unable to communicate with DCNM. Reconnecting: GV Orbit Control is trying to reach DCNM.

6 Do not configure any parameters found under Ports or Streams. These are shown for information purposes only.

Use the Path Manager to view and troubleshoot the flow of streams through the switch fabric. See [Path Manager Tasks](#), on page 270.

Configuring Network Switch Redundancy to Support SMPTE ST 2022-7

This topic describes the theory of how to implement network redundancy, and as such, information is provided as an example that can be used for any SMPTE ST 2022-7 compatible equipment.

To make streaming more reliable over an IP network, the implementation of SMPTE ST 2022-7 seamless protection switching depends on stream redundancy. This protection scheme transmits two identical packet streams over physically separate network routes (shown as Red LAN and Blue LAN in the figure below), so that if packets from one network are lost or delayed, the data can be reconstructed using packets from the second network stream. This process is seamless because switching between the streams is instantaneous and does not impact content.

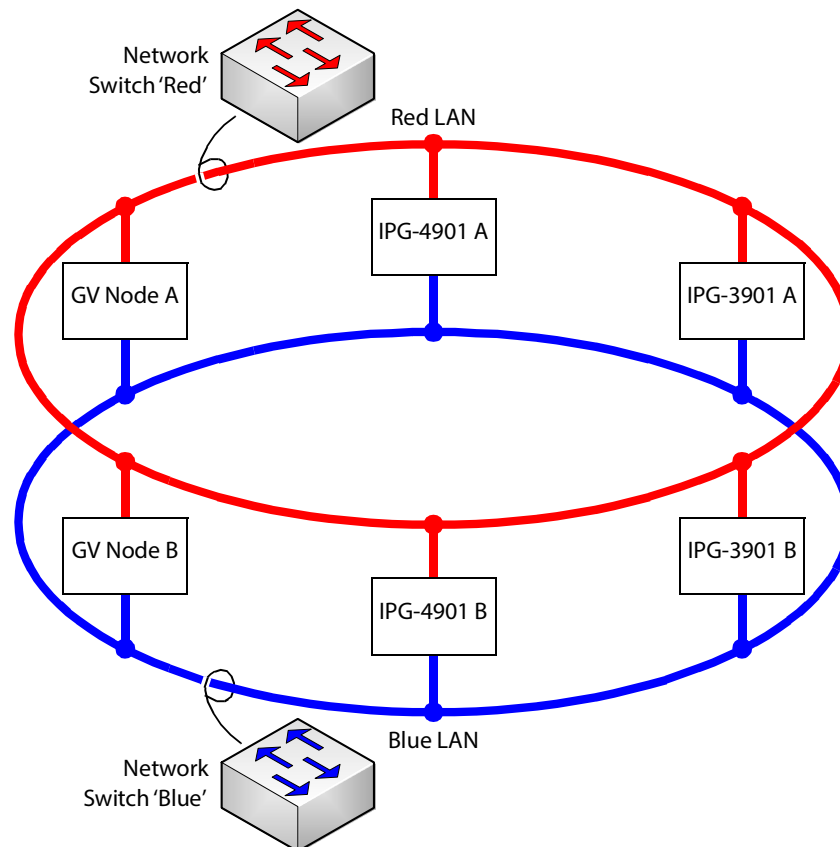

PREREQUISITES:

- At least two DCNM-compliant switches must be used for this application. Contact Grass Valley for more information about switch compatibility. See [Grass Valley Technical Support](#), on page 845.

- For any GV Node frame:
 - a In iControl's GV Node Manager, make sure to set **redundancy** to ON. See the GV Node User Manual for more information.
 - b In GV Orbit Control, set **2022-7 Mode** and configure the **Redundancy Port** parameter. See [Configuring a GV Node Device](#), on page 163.
- For any IPG-4901 / IPG-3901 card
 - a In iControl's **Network panel, Settings** tab, for the **ETH 2 Port**, make sure to set the Operation Mode to **Redundancy**. See the IPG-4901 Guide to Installation and Operation for more information.
 - b In GV Orbit Control, set the **Operation Mode** to **Redundancy**. See [Configuring an IPG-3901 / IPG-4901 Device](#), on page 174.
- For certain third-party devices you may have to configure port redundancy manually. See [Setting Port Redundancy for Many Devices at Once](#), on page 51.

To configure SMPTE ST 2022-7 example

- 1 Add the following devices to the Topology: from the **Device Library, Virtual Device**, add the following device bubbles to the Topology. See [To add a Virtual Device to a topology](#), on page 44.

Quantity	Device
2	Network Switch
2	IPG-3901
2 × 3 instances in a group	Camera
2 × 3 instances in a group	Monitor

Arrange the devices on the Topology as shown below.

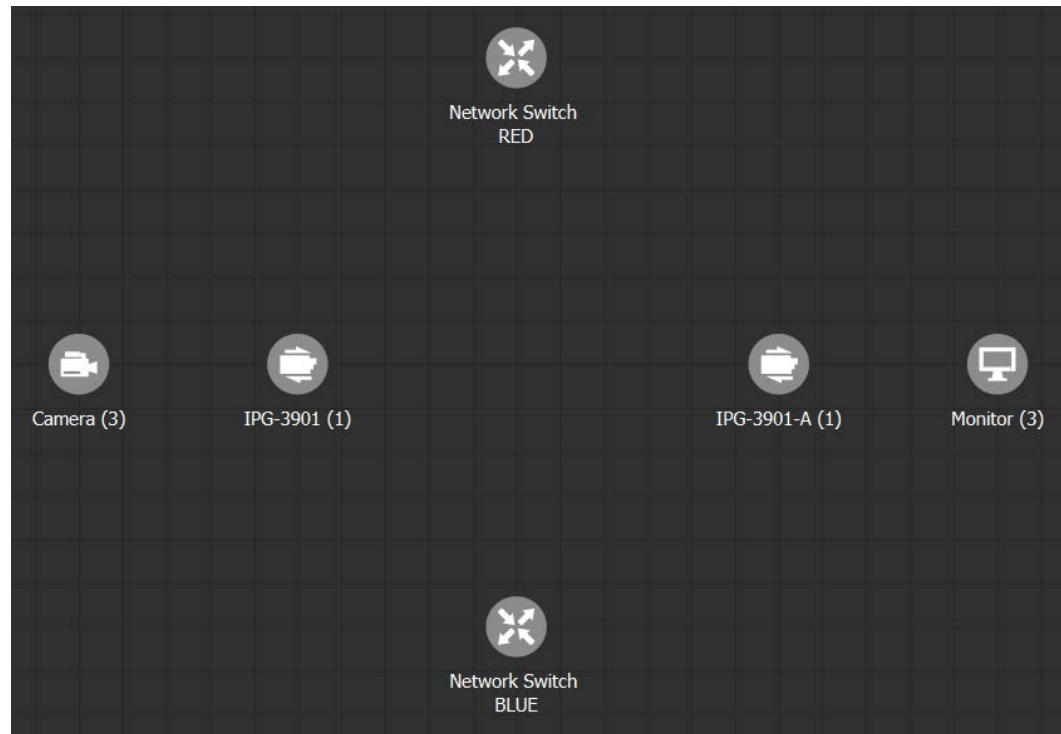

- 2 Activate the topology. See [Activating a Topology](#), on page 66.
- 3 Configure the devices on the Topology. See [Special Devices](#), on page 161. For any other device, see [Adding Devices to a Topology](#), on page 44.

- Click Quick Connect to link the devices as shown below. See [Using Quick Connect to Link all Devices in a Topology](#), on page 53. See also [Methods to Link Devices in a Topology](#), on page 53.

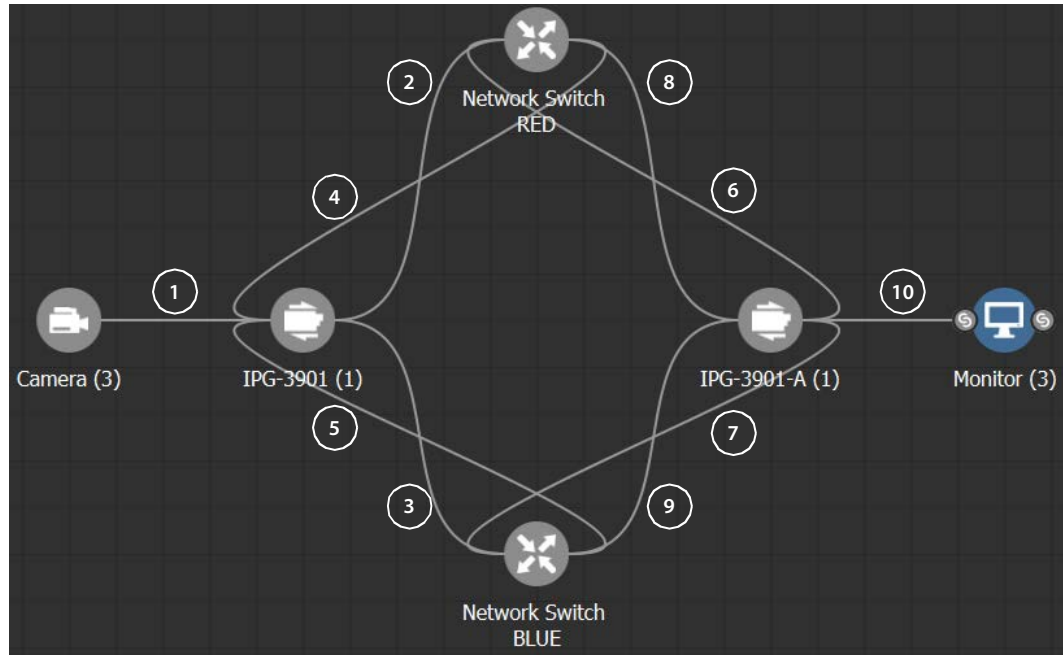

Much more elaborate systems can be configured. The objective is to connect all SMPTE ST 2022-7 IP devices (#2 to #9) to both network switches (RED and BLUE).

- If you are manually making the connections between the devices, select the links between devices, one at a time, to make the connections between devices as shown below. See [Manually Setting the Link's Physical Connection Parameters \(Sources and Destinations\)](#), on page 57. If you use Quick Connect, this is not necessary.

Link			Make the following connections	
#	From	To	From	To
1	Camera	IPG-3901	Cam1 Cam2 Cam3	SDI to 1 (Input Port Id: 3) SDI to 2 (Input Port Id: 4) SDI to 3 (Input Port Id: 5)
2	IPG-3901	Network Switch RED	ETH1	SwitchIn1
3	IPG-3901	Network Switch BLUE	ETH2	SwitchIn1
4	Network Switch RED	IPG-3901	SwitchOut1	ETH1
5	Network Switch BLUE	IPG-3901	SwitchOut1	ETH2
6	IPG-3901-A	Network Switch RED	ETH1	SwitchIn2

Link			Make the following connections	
#	From	To	From	To
7	IPG-3901-A	Network Switch BLUE	ETH2	SwitchIn2
8	Network Switch RED	IPG-3901-A	SwitchOut2	ETH1
9	Network Switch BLUE	IPG-3901-A	SwitchOut2	ETH2
10	IPG-3901	Camera	SDI to 1 (Output Port Id: 3) SDI to 2 (Output Port Id: 4) SDI to 3 (Output Port Id: 5)	Mon1 Mon2 Mon3

Configuring an NVISION Hybrid Series Router

To control an NVISION Hybrid Series Router, GV Orbit Control uses the NP0016 router control protocol. The following NVISION Hybrid Routers are supported: NV8140, NV8144, NV8280, NV8576 or NV8576 Plus. Once the IP address(es) have been added to the Control Port(s) that connects to the NVISION Hybrid Series Router, the router's configuration is read into GV Orbit Control, and the router's card types and ports are automatically configured within GV Orbit Control.

PREREQUISITE: You must have a list of the card type for each slot in the router's frame. This information may be available in the router's MRC configuration software.

LIMITATIONS:

- The disembedder / embedder output card is currently not supported.
- The following topology use case is unsupported.

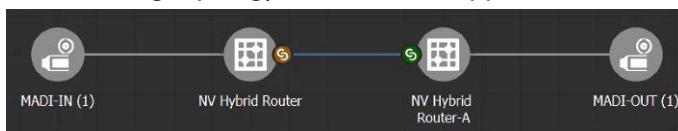

The tieline between two NVISION Hybrid Routers should not be MADI (for example, to link between a MADI source and a MADI destination). Taking a MADI source to a MADI destination will only work if both of them are directly connected to the same NVISION Hybrid Series Router.

- The following topology use case does not support lock and protect from a third-party control system on the NVISION Hybrid Router for a Logical Destination.

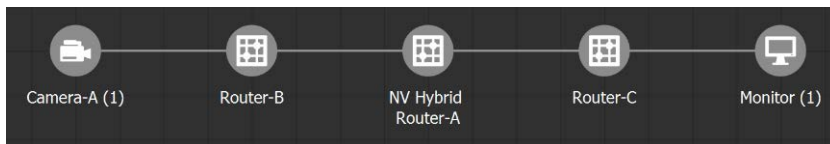

Any output of a NVISION Hybrid Router that is connected to another router cannot be locked in GV Orbit Control. GV Orbit Control will only update the lock/protect status of a destination which is directly connected to the NVISION Hybrid Router (that is, without any other devices in-between).

To configure an NVISION Hybrid Series Router Device

- 1 Add the **NV Hybrid Router** device to the Topology: from the **Device Library, Virtual Device**, find the **NV Hybrid Router** device bubble. See [To add a Virtual Device to a topology](#), on page 44.

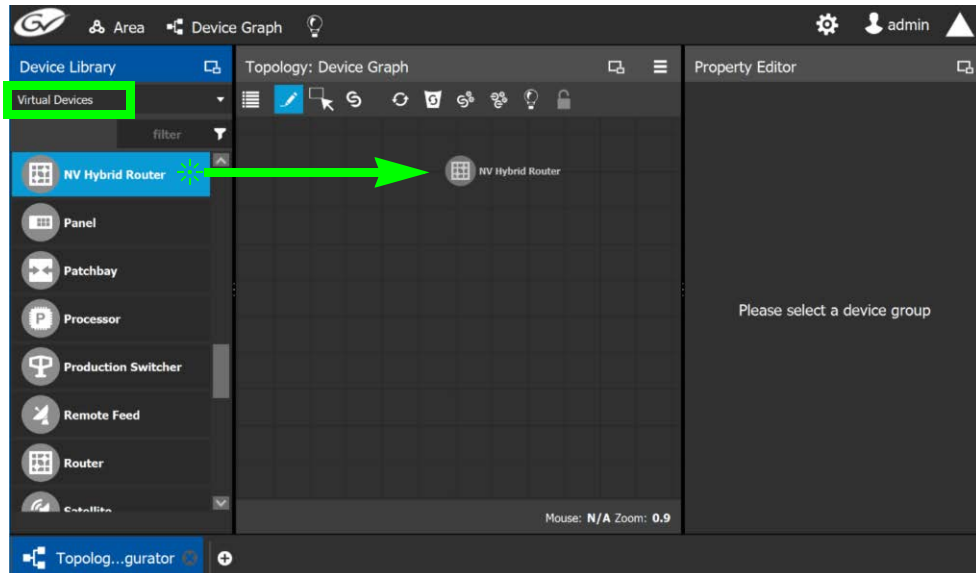

- 2 The control port(s) must be configured to allow communication with the router thereby permitting GV Orbit Control to control the router. NVISION Hybrid Series Routers are controlled through the NP0016 router control protocol.
Select the **NV Hybrid Router** bubble and click **New**  next to **Control Port** at the top of the **Property Editor** and select the router's control protocol from the list. **Dummy** can be used for testing purposes (or pre-deployment) when the actual router model is unknown. See also [Defining Device Properties](#), on page 61 for more information.

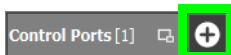

A tab for the selected router model appears. Select this tab to configure the control port.

If the router has a second redundant network connection for controlling it, add a second control port and configure it the same way as the first one except for the IP address which must reflect that of the router's second network connection.

Specifically, you must set the router's control port **IP Address** and **IP Port** number parameters.

Router Control Protocol	See
NP0016 Compact Router	NP0016 Compact Router Control Port Configuration Parameters , on page 246
NP0016 Enterprise Router	NP0016 Enterprise Router Control Port Configuration Parameters , on page 246

To delete a control port, see [To delete a router's control port](#), on page 245.

- 3 Activate the topology. See [Activating a Topology](#), on page 66.

The **Connection State 1 / 2** status for the control port(s) becomes **Online** when is has successfully connected to the NVISION Hybrid router.

Once GV Orbit Control has connected to the NVISION Hybrid Router through the Control Port, it reads the router's configuration to then automatically configure the NVISION Hybrid Router device properties in GV Orbit Control accordingly. Should the NVISION Hybrid router's configuration change (for example, changes have been made to the type and slot location of the router's cards), the router's configuration can be re-loaded into GV Orbit Control; see [To automatically refresh the NVISION Hybrid router's card information in GV Convergent](#), on page 240.

- 4 Deactivate the topology. See [Making an Active Topology Inactive](#), on page 67.
- 5 Configure the NVISION Hybrid Series Router properties. See also [Description of Common Device Properties](#), on page 162.

Parameter	Description
Network Host Name	The hostname is the unique name by which the associated NVISION Hybrid Series Router is known on the network.
Audio Physical Level ID	From the NVISION Hybrid Series Router's configuration, specify the level ID number that has been assigned to the router's audio matrix. Usually this is 2.
Video Physical Level ID	From the NVISION Hybrid Series Router's configuration, specify the level ID number that has been assigned to the router's video matrix. Usually this is 1.
NVision Hybrid Router Type	Shows the router's model type. This is automatically read from the router.
Advanced > Internal Wiring Done	Shows if the internal modeling of the NVISION Hybrid Router is complete.

- 6 This step is optional; setting the **Card Type** for each slot in the router's frame can automatically be done by GV Orbit Control: To automatically update GV Orbit Control's configuration when the type and slot location of the cards have been changed in the router, see [To automatically refresh the NVISION Hybrid router's card information in GV Convergent](#), on page 240.

Manually set the router's card type for any of the router's input and output slots that need to be updated: select an **Input Slot** or **Output Slot** in the router's frame in the

Property Editor and then set the card type in the **Card Type** parameter. If the slot has no card installed in it, set the **Card Type** parameter to **NONE**.

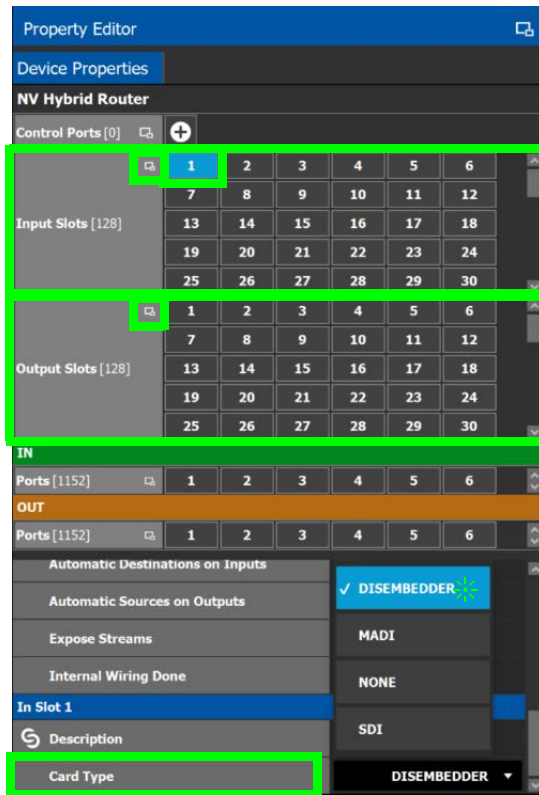

- 7 Select each input or output port to configure them individually. These are the configuration parameters for each of the router's input/output ports. See also [Description of Common Device Properties](#), on page 162.

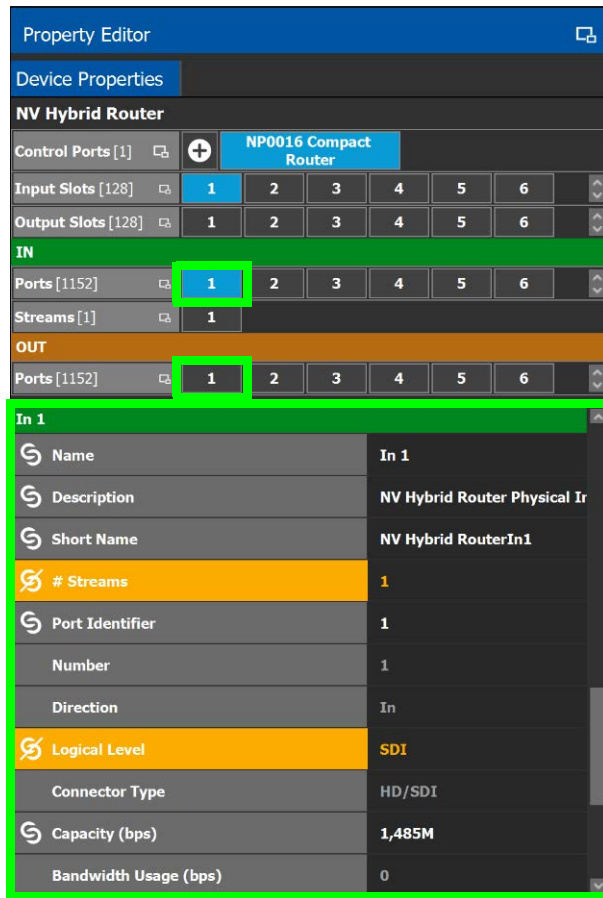

Parameter	Description
Port Identifier	This is the generic identifier of the port within GV Orbit Control.
Number	This shows the current status for information purposes.
Direction	
Connector Type	
Capacity (bps)	The stream's data rate.
Bandwidth Usage (bps)	This shows the current status for information purposes.
Embedder bypassed	Shows the current embedder status for the selected output port according to the current path being routed. See also Path Manager Tasks , on page 270. When set, the output embedder is not being used. When deselected, the output embedder is being used.

- Select each stream found under each input and output port to configure them individually. These are the configuration parameters for the individual streams carried on a network port. See also [Description of Common Device Properties](#), on page 162.

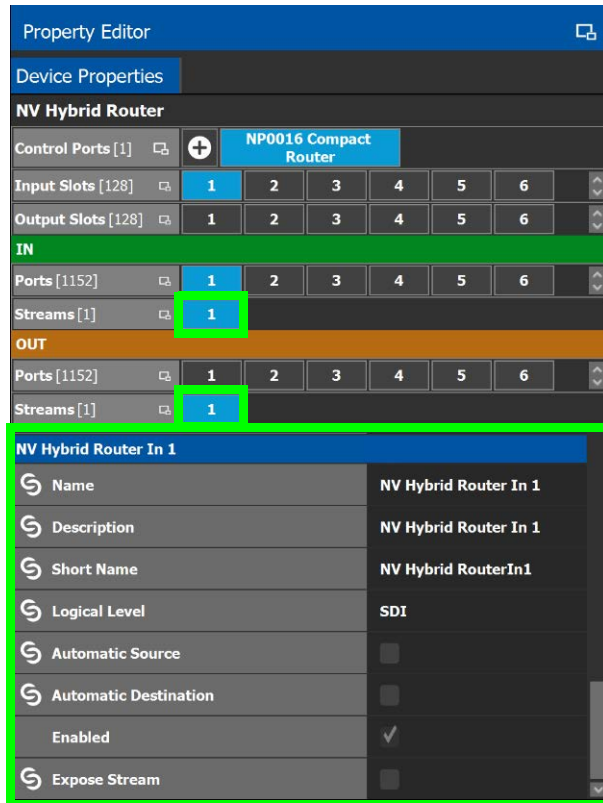

To automatically refresh the NVISION Hybrid router’s card information in GV Orbit Control

When the router has been reconfigured with new or different cards, GV Orbit Control can read the router’s configuration again to automatically configure the NVISION Hybrid Router device properties in GV Orbit Control accordingly.

- De-activate the topology if activated. See [Making an Active Topology Inactive](#), on page 67.
- Select one of the router’s control ports.
- Scroll-down the router’s **Device Properties** list to the control port.



- Click **Update Slotted Cards** and then click OK.
GV Orbit Control reads the router’s configuration to then automatically configure the NVISION Hybrid Router device properties in GV Orbit Control accordingly.
- Activate the topology. See [Activating a Topology](#), on page 66.

Configuring Router Devices

The following procedure configures a router device. Different models of routers use a range of control protocols that GV Orbit Control uses to control the router. Each router control protocol is individually covered in follow up procedures: see also [Configuring a Router's Control Port](#), on page 244.

For more information about how GV Orbit Control manages a router's Lock, Protect, and Release, see also [About Lock, Protect, and Release](#), on page 291.

To configure a Router Device

- 1 Add the Router device to the Topology: from the **Device Library, Virtual Devices**, find the **Router Device** bubble. See [To add a Virtual Device to a topology](#), on page 44.
- 2 Add and configure router control port(s) according to the router model you want to control. Control port(s) must be configured to allow communication with the router thereby permitting GV Orbit Control to control the router; see [Configuring a Router's Control Port](#), on page 244.
- 3 Select the router's tab (next to **Control Port** at the top of the **Property Editor**) to configure the Device Properties in the **Property Editor**. See also [Description of Common Device Properties](#), on page 162.

Parameter	Description
Network Host Name	The hostname is the unique name by which the associated router is known on the network.
Physical Level ID	Set the Physical Level ID value that has been configured for the corresponding router to be controlled by this device instance. To obtain this value, use the router's native configuration interface.
Advanced > Default Connector Type	The router's physical interface port connector: HD/SDI, IP/RJ-45, MADI.
Controller Starting Input	The starting input port number from which you want to control the router's physical level.
Controller Starting Output	The starting output port number from which you want to control the router's physical level.

- 4 Set the number of physical input and output connectors being used on the router in # **Input Connectors** and # **Output Connectors**.

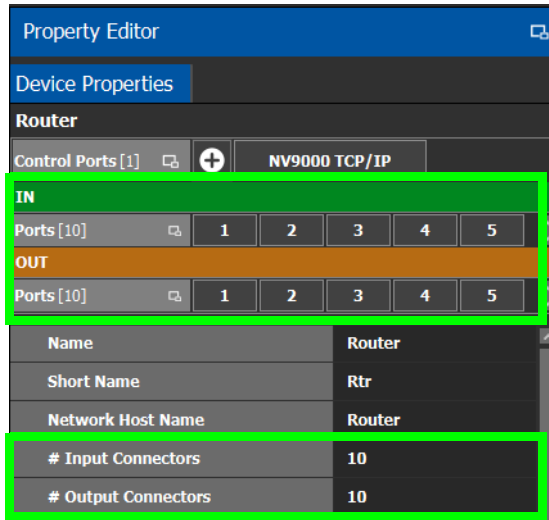

The configuration for these ports become available as **Ports** under **IN** and **OUT**.

- 5 Select each input or output port to configure them individually. These are the configuration parameters for each of the router's input/output ports. See also [Description of Common Device Properties](#), on page 162.

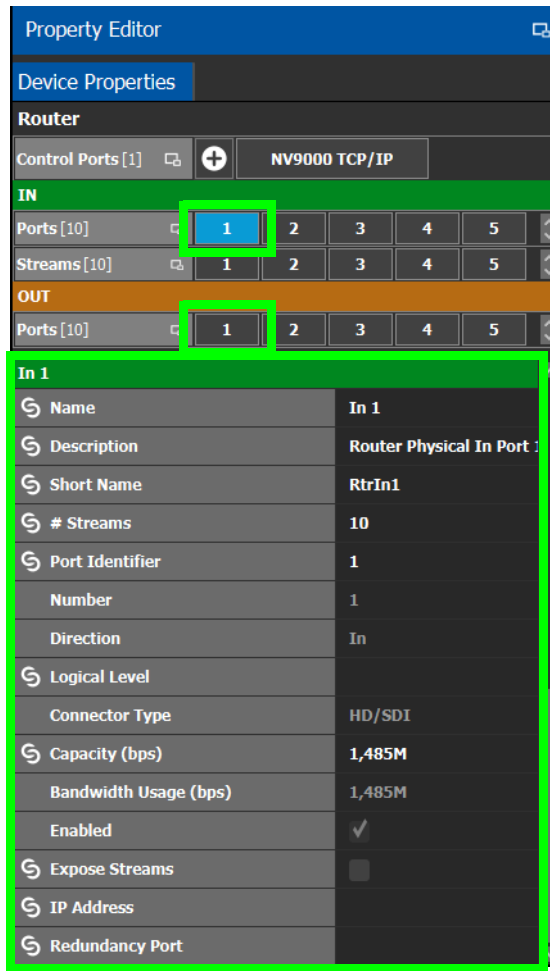

Parameter	Description
Port Identifier	This is the generic identifier of the port within GV Orbit Control.
Number	This shows the current status for information purposes.
Direction	
Connector Type	
Capacity (bps)	
Bandwidth Usage (bps)	This shows the current status for information purposes.
IP Address	This is the interface IP address of the selected port. This is currently not used in the router virtual device.
Redundancy Port	Associate this port with another port to create a redundant network traffic flow path for failover protection. The associated port will not be available to carry other traffic.

- 6 Select each stream found under each input and output port to configure them individually. These are the configuration parameters for the individual streams carried on a network port. See also [Description of Common Device Properties](#), on page 162.

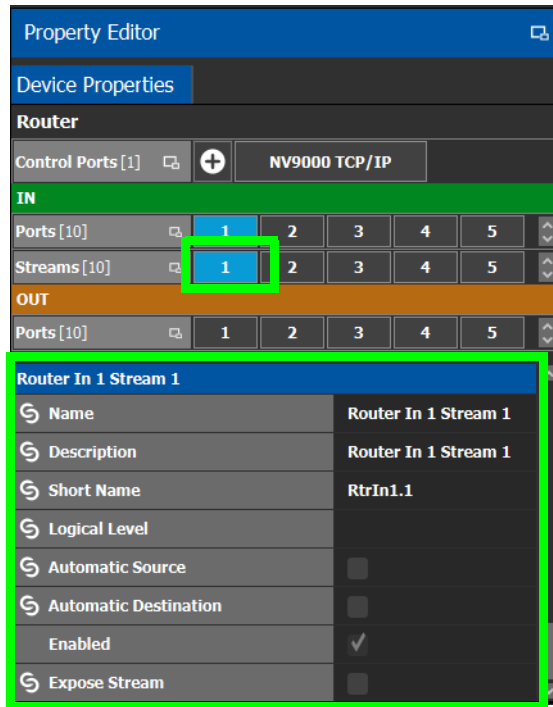

Configuring a Router's Control Port

Control port(s) must be configured to allow communication with the router thereby permitting GV Orbit Control to control the router. There are many types of control ports suited to the router's individual model or control protocol. First, you must add a control port to the router's configuration in GV Orbit Control and then configure it.

PREREQUISITE: Add a router device to the Topology Configurator. See [To configure a Router Device](#), on page 241.

To add a router control port

- 1 Select the **Router** bubble on the Topology Configurator and then select **Device Properties** and click **New**  next to **Control Port** at the top of the **Property Editor** and select the router's model / control protocol from the list. **Dummy** can be used for testing purposes (or pre-deployment) when the actual router model is unknown. See also [Defining Device Properties](#), on page 61 for more information.



A tab for the selected router model appears. Select this tab to configure the control port. The control port(s) must be configured to allow communication with the router thereby permitting GV Orbit Control to control the router.

If the router has a second redundant network connection for controlling it, add a second control port and configure it the same way as the first one except for the IP address which must reflect that of the router's second network connection.

- 2 Configure the control port. See below.

To delete a router's control port

Delete a router's control port as follows.

- 1 De-activate the topology if activated. See [Making an Active Topology Inactive](#), on page 67.
- 2 Select one of the router's control ports.
- 3 Scroll-down the router's **Device Properties** list to the control port

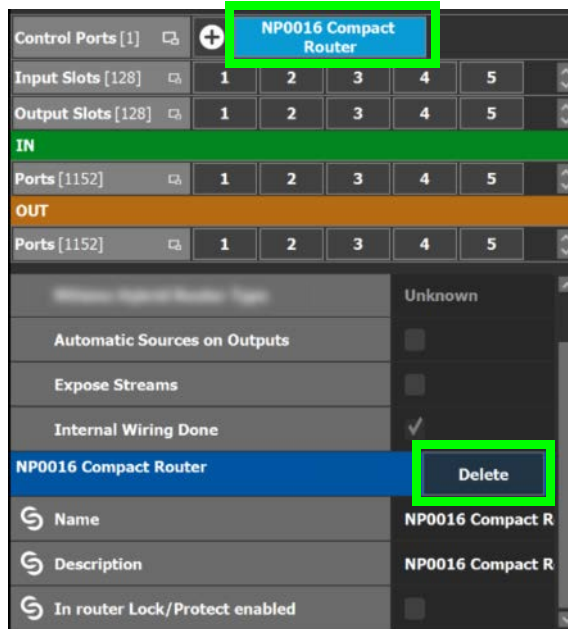

- 4 Click **Delete**.

Supported router control protocols

The following router control protocols are supported.

Router Control Protocol	See
NP0016 Compact Router	NP0016 Compact Router Control Port Configuration Parameters , on page 246
NP0016 Enterprise Router	NP0016 Enterprise Router Control Port Configuration Parameters , on page 246
NS-BUS	NS-BUS Control Port Configuration Parameters , on page 249
NV9000 TCP/IP (NP0017 device-based)	NV9000 TCP/IP Control Port Configuration Parameters , on page 249
SAM SW-P-08 TCP/IP	SAM SW-P-08 TCP/IP Control Port Configuration Parameters , on page 250

NP0016 Compact Router Control Port Configuration Parameters

See also [Description of Common Device Properties](#), on page 162.

Parameter	Description
IP Address	The network IP address for the associated router's management or control port Ethernet address.
Connection State 1	<p>Connection State 1 shows the connection status of the router with the primary server of a server group.</p> <p>Connection State 2 shows the connection status of the router with the secondary server of a server group. See Configuring a Controller Group, on page 19.</p> <p>unknown: The topology is inactive (see Activating a Topology, on page 66) or the router does not have network connectivity to the GV Orbit Server(s).</p> <p>offline: The router does not have network connectivity to the GV Orbit Server(s).</p> <p>online: The router is connected to the GV Orbit Server(s).</p>
Connection State 2	
Connections From Multiple Servers	Set this if the router supports multiple concurrent connections to it. When set, this allows GV Orbit Control main and backup servers to connect at the same time to the router, thereby increasing system availability.
IP Port	Port number for the IP control port stream used by the router. The default is 5194.
In router Lock/Protect enabled	<p>Set to transfer the management of Locks/Protects from the GV Orbit Control control system to the Router for destinations that are directly connected to this router.</p> <p>Deselect to manage all Lock/Protect in GV Orbit Control exclusively. See About In router Lock/Protect enabled for a Router using NP0016 router control protocol, on page 248.</p>

NP0016 Enterprise Router Control Port Configuration Parameters

The enterprise router control port supports the protocol's 'Coherent take' command when performing multiple crosspoint changes at the same time. See also [Description of Common Device Properties](#), on page 162.

Parameter	Description
IP Address	The network IP address for the associated router's management or control port Ethernet address.

Parameter	Description
Connection State 1	<p>Connection State 1 shows the connection status of the router with the primary server of a server group.</p> <p>Connection State 2 shows the connection status of the router with the secondary server of a server group. See Configuring a Controller Group, on page 19.</p> <p>unknown: The topology is inactive (see Activating a Topology, on page 66) or the router does not have network connectivity to the GV Orbit Server(s).</p> <p>offline: The router does not have network connectivity to the GV Orbit Server(s).</p> <p>online: The router is connected to the GV Orbit Server(s).</p>
Connection State 2	
Connections From Multiple Servers	<p>Set this if the router supports multiple concurrent connections to it. When set, this allows GV Orbit Control main and backup servers to connect at the same time to the router, thereby increasing system availability.</p>
IP Port	<p>Port number for the control port stream used by the router. The default is 5194.</p>
In router Lock/Protect enabled	<p>Set to transfer the management of Locks/Protects from the GV Orbit Control control system to the Router for destinations that are directly connected to this router.</p> <p>Deselect to manage all Lock/Protect in GV Orbit Control exclusively. See About In router Lock/Protect enabled for a Router using NP0016 router control protocol, on page 248.</p>
Use Coherent Take Message	<p>Set for GV Orbit Control to use the protocol's 'Coherent take' command when performing multiple crosspoint changes at the same time for this router.</p>

About In router Lock/Protect enabled for a Router using NP0016 router control protocol

For a router using the NP0016 router control protocol, Lock, Protect, and Release have different behaviors depending on whether the **In router Lock/Protect enabled** parameter is set in the Router Control Port configuration.

In router Lock/Protect enabled parameter	Description
Set	<p>For destinations that are directly attached to the router, this setting transfers the management of Locks/Protects from the GV Orbit Control control system to this router, thereby allowing better third-party router control integration with GV Orbit Control. This is called in router lock and protect.</p> <p>This setting keeps the router's Lock/Protect and GV Orbit Control's Lock/Protect in synchronization as follows:</p> <ul style="list-style-type: none"> • If a Lock/Protect is updated in the router, it's also updated in GV Orbit Control. • If a Lock/Protect is updated in GV Orbit Control, it's also updated in the router. <p>This option has the following effects and consequences: When locks / protections are created in the router through another control system, the user name used to create the locks / protections will be unknown to GV Orbit Control's user management mechanism. These unknown users are treated as <i>admin</i> users within GV Orbit Control. Note that <i>admin</i> users within GV Orbit Control can override the locks and protections of any other GV Orbit Control user. This means that any third-party control system will override locks / protections made in GV Orbit Control.</p>
Deselected	<p>GV Orbit Control stores the locks in its database and they are preserved after a restart/reboot. As such, destinations will remain locked/protected. GV Orbit Control system does not read a lock from a router and does not control a lock in the router. This is called in control system lock and protect. This is how all other types of routers are managed.</p> <p>Locks and protections are made in GV Orbit Control without consideration of any locks and protections that have been made through another control system (locks and protections are not synchronized between GV Orbit Control and the router). This can result in unexpected routing behavior such as a failed path that looks as though it should have been successful.</p>

See also [About Lock, Protect, and Release](#), on page 291.

NS-BUS Control Port Configuration Parameters

See also [Description of Common Device Properties](#), on page 162.

Parameter	Description
Connection State 1	<p>Connection State 1 shows the connection status of the router with the primary server of a server group.</p> <p>Connection State 2 shows the connection status of the router with the secondary server of a server group. See Configuring a Controller Group, on page 19.</p> <p>unknown: The topology is inactive (see Activating a Topology, on page 66) or the router does not have network connectivity to the GV Orbit Server(s).</p> <p>offline: The router does not have network connectivity to the GV Orbit Server(s).</p> <p>online: The router is connected to the GV Orbit Server(s).</p>
Connection State 2	
IP Address	The network IP address for the associated router's management or control port Ethernet address.
IP Port	Port number for the control port stream used by the router. The default is 37800.
Multiple Connections Capable	Set this if the router supports multiple concurrent connections to it. When set, this allows GV Orbit Control main and backup servers to connect at the same time to the router, thereby increasing system availability.

NV9000 TCP/IP Control Port Configuration Parameters

This option uses the NP0017 device-based router control protocol to control an NV9000 router through Ethernet network link(s). If the router has two control ports, add a second control port, one for each control port on the router. See also [Description of Common Device Properties](#), on page 162.

Parameter	Description
IP Address	The network IP address for the associated router's management or control port Ethernet address.
Connection State 1	<p>Connection State 1 shows the connection status of the router with the primary server of a server group.</p> <p>Connection State 2 shows the connection status of the router with the secondary server of a server group. See Configuring a Controller Group, on page 19.</p> <p>unknown: The topology is inactive (see Activating a Topology, on page 66) or the router does not have network connectivity to the GV Orbit Server(s).</p> <p>offline: The router does not have network connectivity to the GV Orbit Server(s).</p> <p>online: The router is connected to the GV Orbit Server(s).</p>
Connection State 2	

Parameter	Description
Connections From Multiple Servers	Set this if the router supports multiple concurrent connections to it. When set, this allows GV Orbit Control main and backup servers to connect at the same time to the router, thereby increasing system availability.
IP Port	Port number for the control port stream used by the router.
Protocol	The IP connection protocol. TCP: A point-to-point connection protocol. UDP: A stateless connection protocol that can also broadcast data to more than one device.

Lock, Protect, and Release with the NV9000 Control Port

GV Orbit Control stores the locks in its database and they are preserved after a restart/reboot. As such, destinations will remain locked/protected. The GV Orbit Control system does not read a lock from a router and does not control a lock in the router.

See also [About Lock, Protect, and Release](#), on page 291.

SAM SW-P-08 TCP/IP Control Port Configuration Parameters

Grass Valley/Pro Bel devices including the Sirius router that use the Pro Bel SW-P-08 switcher protocol can be controlled by GV Orbit Control through an IP network. These routers use two control ports to control them.

LIMITATION: GV Orbit Control control of a Sirius router is limited to a maximum of 1152² crosspoints using single-level X-Y control.

To connect the GV Orbit Server to the router

- 1 Add two control ports in GV Orbit Control. See [To add a router control port](#), on page 244.
- 2 Configure both control port configuration parameters. See also [Description of Common Device Properties](#), on page 162.

Parameter	Description
IP Address	The network IP address for the associated router's management or control port Ethernet address.
Connection State 1	Connection State 1 shows the connection status of the router with the primary server of a server group.
Connection State 2	Connection State 2 shows the connection status of the router with the secondary server of a server group. See Configuring a Controller Group , on page 19. unknown: The topology is inactive (see Activating a Topology , on page 66) or the router does not have network connectivity to the GV Orbit Server(s). offline: The router does not have network connectivity to the GV Orbit Server(s). online: The router is connected to the GV Orbit Server(s).

Parameter	Description
Connections From Multiple Servers	Set this if the router supports multiple concurrent connections to it. When set, this allows GV Orbit Control main and backup servers to connect at the same time to the router, thereby increasing system availability.
IP Port	Port number for the control port stream used by the router. The default is 14000.
Matrix ID	A SW-P-08 device can have multiple matrices, each with multiple physical levels. Set the Matrix ID value that has been configured for the corresponding router to be controlled by this device instance. To obtain this value, use the router's native configuration interface. Refer to your router's documentation for more information about this parameter.
Polling	Set this to poll the crosspoint status at regular intervals.
Protocol	The IP connection protocol. TCP: A point-to-point connection protocol. UDP: A stateless connection protocol that can also broadcast data to more than one device.
Use Extended Mode	Set this for GV Orbit Control to try to use the <i>extended</i> command set of the SW-P-08 protocol with the router first. Extended commands allow routers larger than 1023 × 1023 to be controlled. If the router does not support extended commands, the GV Orbit Control will fallback to the standard command set and with it, the associated control limitations.

Configuring a Device that Supports Audio Breakaway/Shuffling such as Audio Live

Audio breakaway and shuffling can be done by Audio Live and by GV Node. Audio Live is designed specifically for audio processing.

About Audio Live

Audio Live is an IP-only device that manages audio feeds only. It accepts a number of AES67 streams as inputs. Internally, it demultiplexes these inputs to obtain a series of mono PCM audio channels which then go through an audio router. Outputs from the router get multiplexed in accordance with the required output configuration. This allows Audio Live to perform breakaway and/or shuffling of mono channel audio feeds, in addition to audio format conversion.

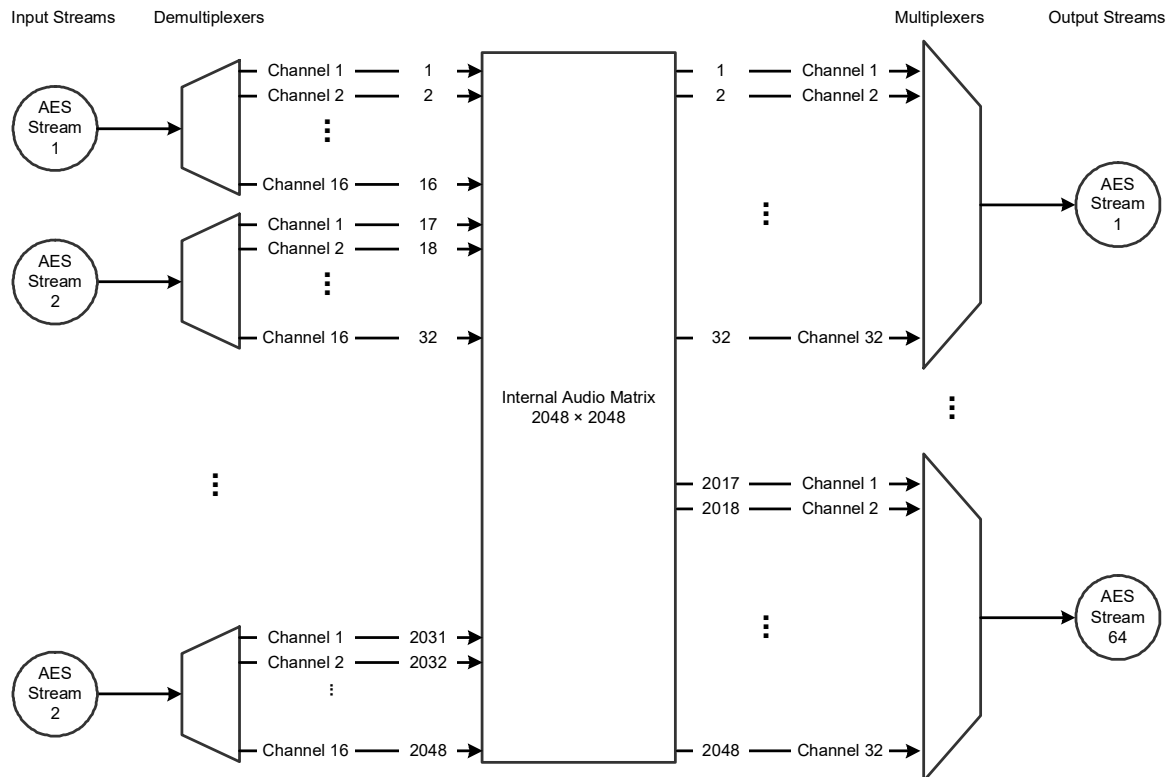

Example Audio Live configuration with 128×16 matrix for the input and 64×32 matrix for the output

The inputs and outputs of an Audio Live are called *spigots*. There are a variety of spigot configurations that are available. See also [How to Know if a Spigot is an Input or an Output](#), on page 184.

GV Orbit Control is able to detect the number of channels in the input spigots and will assign one of the AES67 levels to the input stream for each spigot (for example, AES67-4, AES67-8, AES67-16, AES67-32 or AES67-64). This is conditional on having configured the input spigots in RollCall to not use the **Auto** setting for the number channels. This is shown in the procedure below ([Required Audio Live Configuration in the RollCall Control Panel](#), on page 253).

GV Orbit Control will detect the number of channels in the output spigots and one of the AES67 logical levels will be automatically assigned to the output stream of each output spigot (for example, AES67-4, AES67-8, AES67-16, AES67-32 or AES67-64).

Audio Live can accept audio packets with any packet time on the input. Audio Live can convert audio packet times as well as the number of channels in the streams. For example, an input spigot accepts an AES67 stream with 8 channels and packet time of 1 millisecond, and route the signals to an output spigot with 16 channels and packet time of 250 microseconds. When using audio streams with different packet times however, extra configuration steps are required: see [Required Configuration for Audio Streams with Different Packet Times](#), on page 256.

About the Routing Path of Audio Channels

If there are multiple devices on the topology that can perform audio shuffling, Audio Live will not necessarily always do the shuffle. For example, if the first device reached along the path (from destination to source) is a GV Node, then the GV Node may do the shuffle. It is GV Orbit Control that determines whether and when Audio Live is required for a given route. To know if an Audio Live or GV Node device is currently in use for a given route, use the Path Manager to see if there are tie-line connections to the Audio Live / GV Node device. See [Path Manager Tasks](#), on page 270.

Prerequisites

Audio Live v1.5 or higher must be connected to the network, licensed, and has been previously configured with RollCall.

Required Audio Live Configuration in the RollCall Control Panel

In the *Audio Live User Guide*, see the following topics that must be configured according to your needs.

- 1 In RollCall, set the size of Audio Live's audio matrix (**Maximum Supported Channel Count**) and the number of channels per AES input and output streams. This setting is found under **Audio Live > Setup > System Configuration > Input Configuration** and **Output Configuration**.



- 2 Stop the Audio Live server in **Agent Configuration**; under **Available Agents**, select **Audio Live** and click **Stop**.

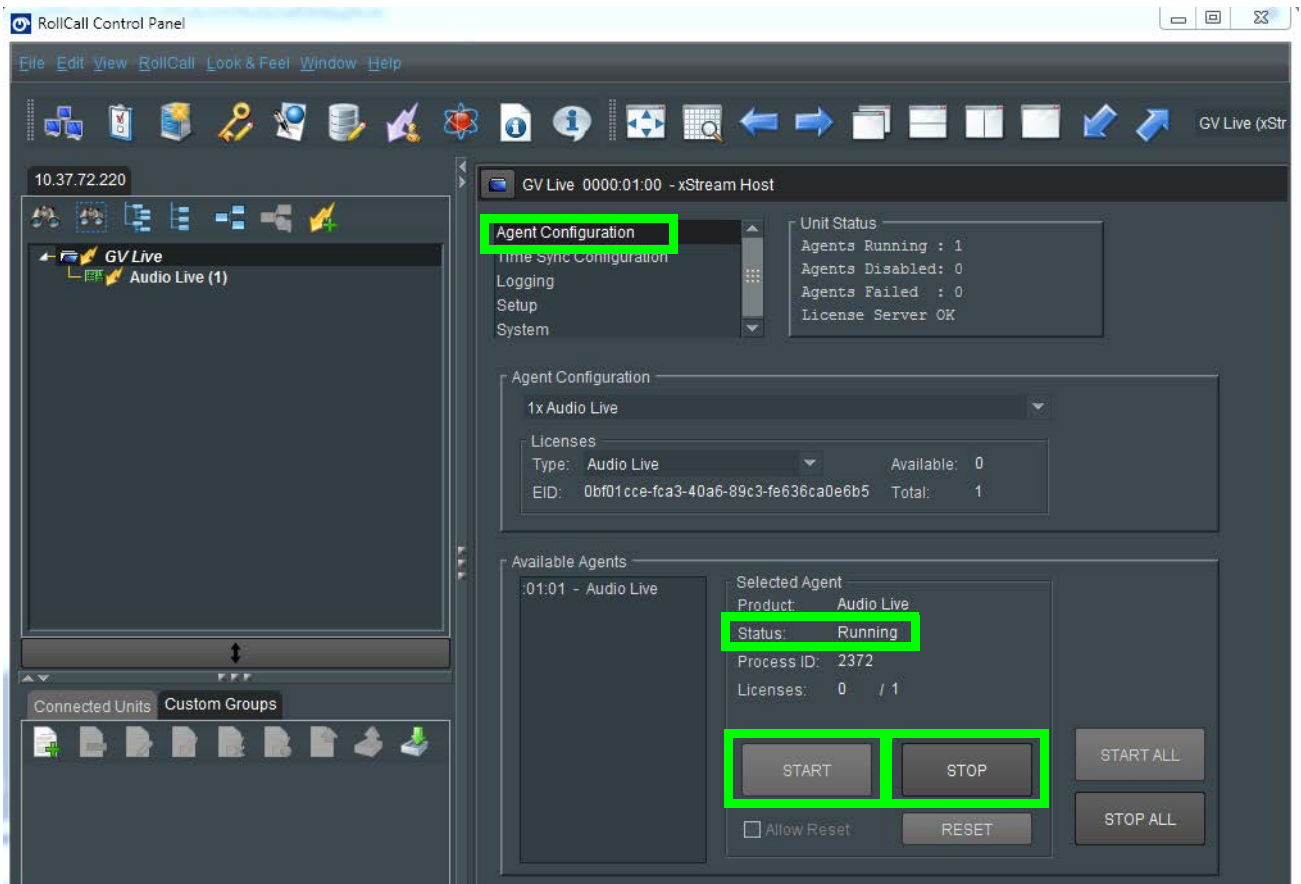

- 3 Once the **Status** under **Selected Agent** becomes **Stopped**, click **Start**.
- 4 In RollCall, set the **Channels** parameter to the maximum number of channels available for *each stream*. This setting is found under **Audio Live > Input > Source Flows > Channels**.

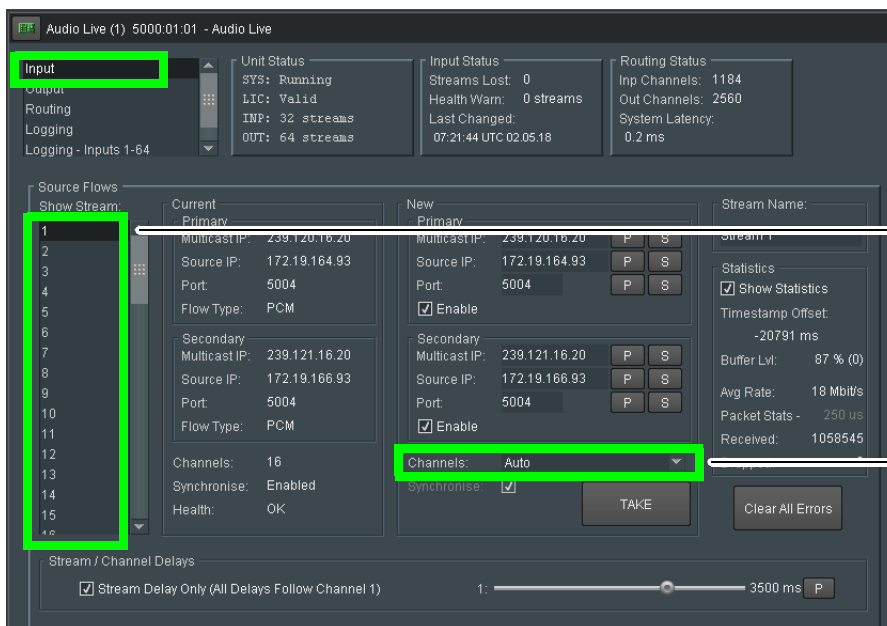

For each available stream, you must...

Set the number of channels to the maximum available in this dropdown. **Note:** the default **Auto** setting will not work.

Setting the maximum number of channels is necessary as GV Orbit Control expects that all channels be available for it to use at any time.

5 Click **Take**.

6 In RollCall under **Audio Live > Output> Dest Flows**:

- Set the **Channels** parameter to the maximum number of channels available for *each stream*. This setting is found under **Audio Live > Output> Dest Flows**.
- Set the **Packet Time** parameter according to the number of channels configured for *each stream*. See table below. This setting is found under **Audio Live > Output> Dest Flows**.

Packet Time	Maximum number of channels that the stream can carry
125us	up to 64 channels
250us	up to 32 channels
500us	up to 16 channels
1 ms	up to 8 channels
4 ms	up to 2 channels

7 Click **Take**.

AES Logical Levels that are used for IP Audio Streams

To support a GVOP device's ability to support a range of audio channels per AES stream (for devices such as Audio Live; see [GVOP Devices](#), on page 46), and on GVOP devices that support this feature, the following logical levels are used according to the number of

channels in the AES stream. See also [Logical Level Editor Tasks](#), on page 30 and [Setting the Logical Levels to be Displayed in the Multilevel Table](#), on page 78.



Logical Level	Description
AES67-4	4 mono audio channels
AES67-8	8 mono audio channels
AES67-16	16 mono audio channels This logical level is interchangeable with the SDI audio logical level.
AES67-32	32 mono audio channels
AES67-64	64 mono audio channels

To see the number of audio channels a given logical level supports, see [Editing a Logical Level](#), on page 35.

Required Configuration for Audio Streams with Different Packet Times

If for a given topology, all audio streams have the same packet time, then the automatically assigned levels to the output spigots will work. If the topology has audio streams with different packet times, you will have to configure the packet times on Audio Live's output spigots. Currently GV Orbit Control is unaware of these settings in RollCall, so you must proceed as follows: duplicate the SDI audio level as many times as there are different packet times. To duplicate an SDI audio level, see [Duplicating a Logical Level](#), on page 33.

For example, to accommodate a 1 microsecond audio packet time, you duplicate the SDI audio level with the **-1** suffix. To accommodate a 250 microseconds audio packet time, you again duplicate the SDI audio level with the **-250** suffix.

You also need to set the proper AES67 levels on the Audio Live output streams in GV Orbit Control. For example:

- If output spigot 1 has been configured with 16 channels at 250 microseconds, then the streams for output spigot 1 should be assigned the **AES67-16-250** level.
- If the output spigot has been configured with 8 channels at 1 ms, then the streams for that spigot should be assigned the **AES67-8-1** level.

Note: You will need to set the level on all output streams of the Audio Live configuration in GV Orbit Control if your topology uses more than one packet time value.

Configuring an Audio Live device in GV Orbit Control

To add an Audio Live device to a topology

- 1 Add the Audio Live device to the Topology: from the **Device Library, Discovered**, find an Audio Live device bubble that you want to control. See [To add a Discovered Device to a Topology](#), on page 48.

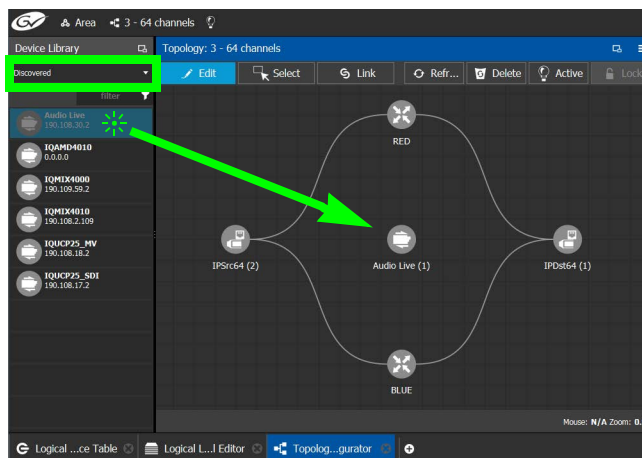

- 2 Click on the name of the device underneath the bubble to name the device or device group. See [To name a device and set the number of devices in the group](#), on page 45.

- On the topology, connect the Audio Live device to the network switches. See [Methods to Link Devices in a Topology](#), on page 53.

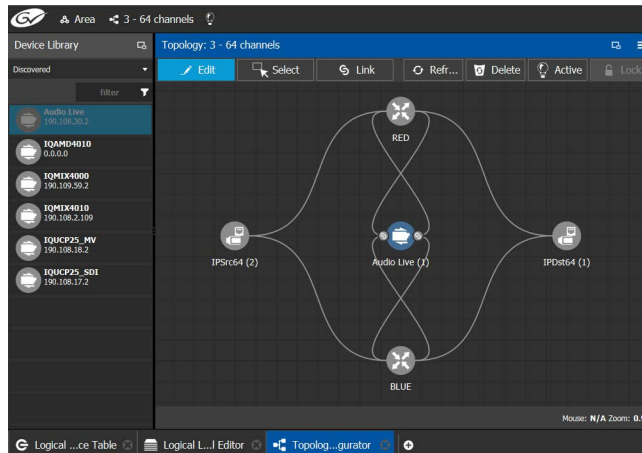

By default, the Audio Live device is created according to the configuration defined in RollCall. The streams are assigned the appropriate AES67 levels, based on the number of channels. The Audio Live can be used as is, without a need to modify the device properties in the Property Editor, unless you need to modify the streams to use custom levels.

- Select the **Audio Live** bubble and configure the Device Properties in the **Property Editor**. See [Defining Device Properties](#), on page 61 for more information.

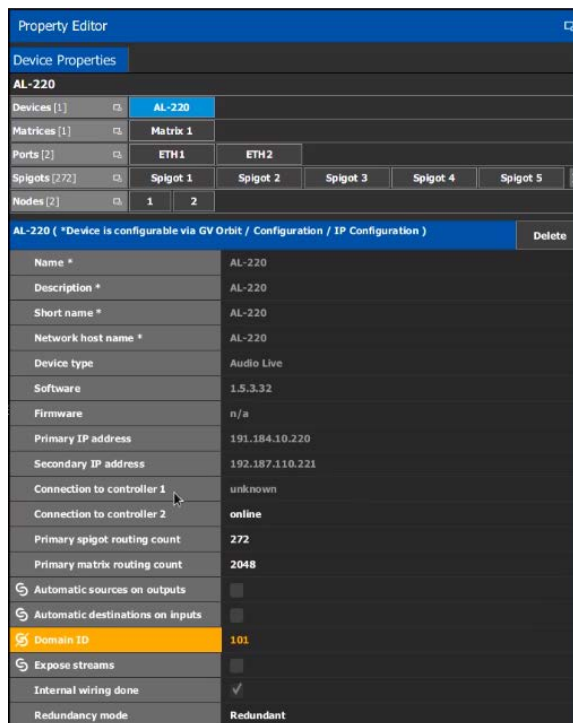

See also [Description of Common Device Properties](#), on page 162.

Parameter	Description
Name (of device bubble)	The name of the Audio Live device set in RollCall. When two Audio Live devices have been configured to be redundant, the name comes from the primary device.
Name (found under Node)	The name of the individual Audio Live device set in RollCall.
Nodes	When two Audio Live devices have been configured to be redundant: Node 1: The Audio Live that has been configured as <i>Redundant - Primary</i> in RollCall. Node 2: The Audio Live that has been configured as <i>Redundant - Secondary</i> in RollCall. See Audio Live Redundancy Support , on page 260.
Software	The firmware version running on the Audio Live device.
Primary IP Address Secondary IP Address	When two Audio Live devices have been configured to be redundant: Primary IP Address: The IP Address of the Audio Live that has been configured as <i>Redundant - Primary</i> . Secondary IP Address: The IP Address of the Audio Live that has been configured as <i>Redundant - Secondary</i> . See Audio Live Redundancy Support , on page 260.
Connection to Controller 1	Connection to Controller 1 shows the connection status of the Audio Live device with the primary server of a server group.
Connection to controller 2	Connection to Controller 2 shows the connection status of the Audio Live device with the secondary server of a server group. See Configuring a Controller Group , on page 19. unknown: The topology is inactive (see Activating a Topology , on page 66) or the Audio Live device does not have network connectivity to the GV Orbit Server(s). offline: The Audio Live device does not have network connectivity to the GV Orbit Server(s). online: The Audio Live device is connected to the GV Orbit Server(s).
Primary spigot routing count	These paramters come from the Audio Live's configuration made in RollCall.
Primary matrix routing count	
Redundancy Mode	Shows the Audio Live's current configuration. Independent: This Audio Live bubble represents a single Audio Live device. Redundant: This Audio Live bubble represents a pair of Audio Live devices operating in a cluster for improved availability. See Audio Live Redundancy Support , on page 260.

- 5 Create the sources and destinations. See [Automatically Creating AES67 Audio Channels for Sources and Destinations](#), on page 266.

- 6 Test the configuration by making takes between a logical source and destination that use the AES67 audio levels. See [Performing a Take in Router Control](#), on page 290.

Known Audio Live limitations

- When choosing an Audio Live spigot to use for the take, GV Orbit Control will only use an output spigot that has the same number of channels as the destination, and only use an input spigot that has the same number of channels as the source. If no such spigot is available, the take will fail. It will not try to use multiple spigots (for example, if the source/destination is 16 channels, it will not try to use 2 spigots, each with 8 channels), and it will not try to use part of a spigot (for example, if the source/destination is 8 channels, it would not try to use the first 8 channels of a 16 channel spigot).
- In the Audio Live configuration, the channel count of an **Input Configuration** and **Output Configuration** cannot be set to **Auto** as GV Orbit Control does not support this setting. See [Required Audio Live Configuration in the RollCall Control Panel](#), on page 253.
- The number of channels on the input stream must match the number of channels on the source stream, and the number of channels on the output stream must match the number of channels on the destination stream.
- For streams that have an AES67-X level, the logical source/destination that is automatically created is not usable. Instead, you must create custom logical sources and destinations, and place the streams in the SDI Audio or audio1 to audio16 level columns instead. See [Required Configuration for Audio Streams with Different Packet Times](#), on page 256.

Audio Live Redundancy Support

Audio Live redundancy is supported in GV Orbit Control systems with Audio Live v1.5.3 firmware version or higher. With this Audio Live firmware, each Audio Live unit can be configured as *Independent*, *Redundant - Primary*, or *Redundant - Secondary*. These configuration parameters are available through the RollCall Unit Redundancy page, for each unit. When two Audio Live units are configured as follows, the units form a cluster for increased availability: Audio Live 1 is configured as *Redundant - Primary* and Audio Live 2 is configured as *Redundant - Secondary*.

Audio Live Network Connections

The Audio Live Primary and Secondary input and output ports from both units must be connected to RED and BLUE network switches and the corresponding spigots/streams must be properly configured.

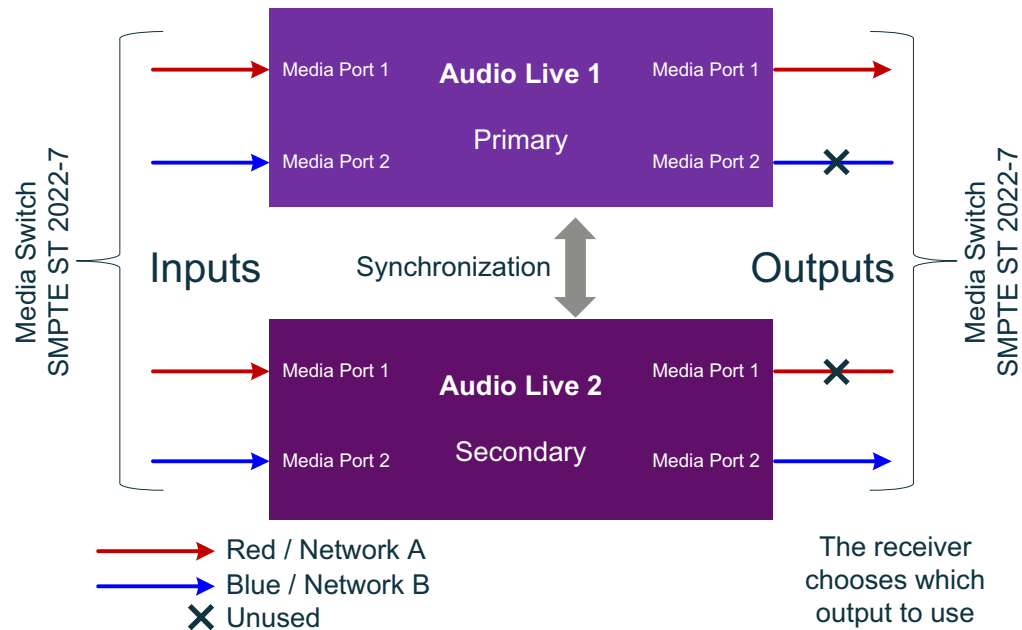

Redundancy on Audio Live was designed to prevent signal loss or signal glitching in case of a hardware failure of one of the two units. In order to achieve this, the Audio Live cluster is using, on the sender side, the primary port from the Primary unit as the cluster primary output, whereas the secondary port of the secondary unit is used as the cluster secondary output.

The secondary output from the primary unit and the primary output from the secondary unit are not used by the GV Orbit Control systems.

On the receiver side, input ports from both Primary and Secondary units are used and join the same flows; primary input from the primary unit and the primary input from the secondary unit, as well as the secondary input from the primary unit and the secondary input from the secondary unit. The input and output ports currently being used are displayed through the Path Manager. See [Path Manager Tasks](#), on page 270.

Required Audio Live Configuration in RollCall

Access the Audio Lives units, one at a time through RollCall and configure them as follows in their **Unit Redundancy** page. For redundancy support, both Audio Live units must be

configured in redundancy mode, one unit as *Redundant - Primary* and the other one as *Redundant - Secondary*.

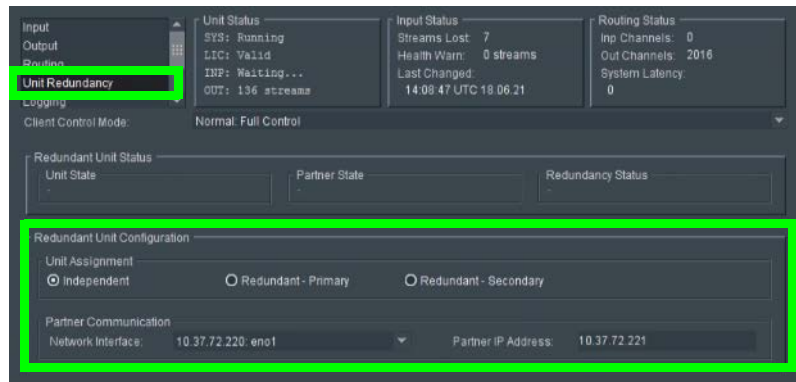

Parameter	Description
Unit State	Shows this unit's state. -: Unknown status. Initializing: Unit is in the process of connecting and synchronizing with the partnered unit. Running: Unit has successfully paired with the partnered unit.
Partner State	Shows the partnered unit's state, when available. -: Unknown status. Running: Unit has successfully paired with this unit.
Redundancy Status	Shows the status of the paired Audio Live units. Matched: The two Audio Live units are operating with redundancy. Error: Configuration or communication issue.
Unit assignment	Set this unit's role. Independent: This unit is not associated with another Audio Live unit; there is no Audio Live redundancy currently enabled. Redundant - Primary: This unit is the primary unit to be associated to another Audio Live unit (the secondary unit) for redundancy through the Partner IP Address parameter. Redundant - Secondary: This unit is the secondary unit to be associated to another Audio Live unit (the primary unit) for redundancy through the Partner IP Address parameter.
Network interface	Set the Ethernet interface on which this Audio Live is to communicate with the other Audio Live. With redundancy, this must be set on both units such that both Audio Live units have network connectivity with each other.
Partner IP Address	With redundancy, set the IP Address of the other Audio Live device. If this is the primary unit, set the secondary unit's IP address. If this is the secondary unit, set the primary unit's IP address.

Both units must be identically configured with respect to any parameter that can affect the output audio. This is done in each Audio Live's RollCall configuration. This includes:

- Spigot routing (destinations and sources).

- Internal channel matrix routing.
- Input and output configurations. In RollCall, set the size of Audio Live’s audio matrix (**Maximum Supported Channel Count**) and the number of channels per AES input and output streams. This setting is found under **Audio Live > Setup> System Configuration > Input Configuration** and **Output Configuration**.





- Input and output delays.
- Timestamp alignment settings.
- Input 2110-31/AES3 selections.
- Input synchronizer selections.
- Output channel counts and packet times.

Once the Audio Live configuration is complete, both units are synchronized in order to exchange flow data in order to handle redundancy.

Redundant Audio Live Configuration in GV Orbit Control

It is important to have both units up-and-running while configuring the Audio Live cluster in GV Orbit Control. Once the Audio Live cluster configuration is completed, the cluster will be discovered in GV Orbit Control systems, as a GVOP discovered device. If there is any configuration issue between the two Audio Live units, causing the cluster to be in a bad state (not synchronizing properly), then the discovered entity will not be discovered under the GV Orbit Control system and if the device is already on the topology, its status will change to offline.

A new icon is used to distinguish between Audio Live units using v1.5.3 firmware and units using an older firmware, regardless of the redundancy mode (Independent or Redundant).

Audio Live Icon	Audio Live Firmware Version	Description
	v1.5.2 or lower	Audio Live redundancy is unsupported.
	v1.5.3 or higher	Audio Live redundancy is supported.

The name of the discovered cluster and its related spigots will be using the ones from the primary Audio Live unit.

Once the cluster is added to the topology, the cluster group device will be listing two nodes corresponding to the two Audio Live units. Each node will provide the Audio Live unit properties (Unit name, hostname, Control IP address, GUID, and so on) and also the specific unit ports and spigots. See [Configuring an Audio Live device in GV Convergent](#), on page 257.

The cluster device group lists the ports and the spigots from those units; the primary port is the one from the primary unit where the secondary port is the one from the secondary unit.

The cluster **Redundancy mode** property will reflect the current cluster status (Independent or Redundant).

The control port status (Online / Offline / Reconnecting) for the cluster is available on the cluster device group and also through the System Status page where the status for both units is also available. See [System Status Task](#), on page 277.

Further notes:

- When replacing a failed unit, it's important to apply the same IP configuration to the new unit as was applied to the previous faulty unit, otherwise tally issues may occur.
- Independent Audio Live units from existing topologies, using an older Audio Live firmware, cannot be used for redundancy. Those units must be deleted from the topology, upgraded to v1.5.3 firmware (or higher), configured in a cluster mode and then they will be discovered by GV Orbit Control systems.
- No changes will be noticed if an independent Audio Live unit, using v1.5.3 Audio Live firmware (or higher) is added to the topology, except the new icon and the new unit Redundancy Mode, shown as **Independent**.
- Cisco DCNM host policies are only created for the streams corresponding to the ports that are actually used by GV Orbit Control systems.

Configuring an IQAMD40 Device

About IQAMD40

The IQAMD40 provides multichannel MADI-to-IP interfacing, and has been developed to allow high-density audio integration into Ethernet IP networks. Using industry standard AES67 encapsulation and an IP interface enables the IQAMD40 to interface directly with many common audio desks and systems.

PREREQUISITES: IQAMD40 must be connected to the network, licensed, and has been previously configured with RollCall.

IQAMD40 Integration in GV Orbit Control

GV Orbit Control supports the routing of audio signals through an IQAMD40 card.

To add an IQAMD device to a topology

- 1 Add the IQAMD device to the Topology: from the **Device Library**, **Discovered**, find an IQAMD device bubble that you want to control. See [To add a Discovered Device to a Topology](#), on page 48.

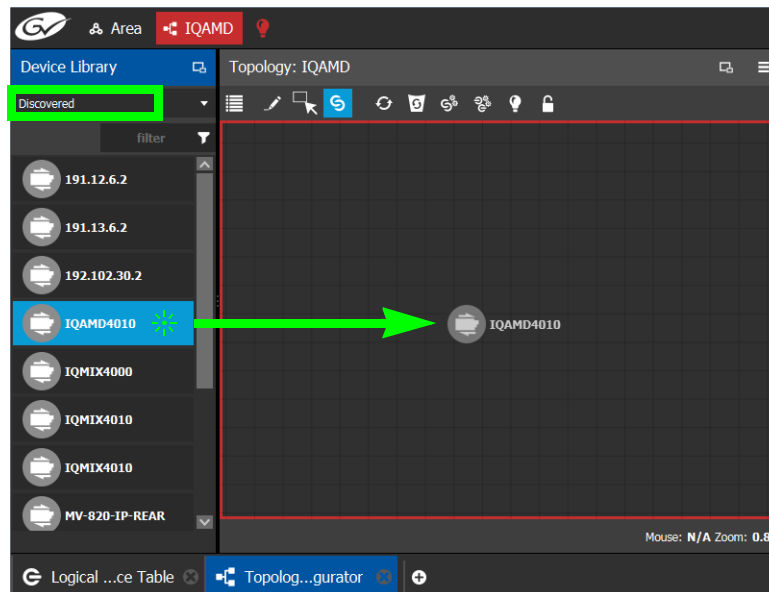

- On the topology, connect the IQAMD device to the network switches. See [Methods to Link Devices in a Topology](#), on page 53.

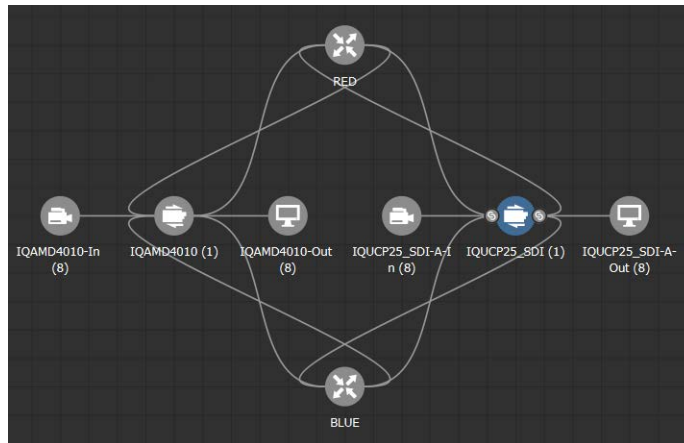

Automatically Creating AES67 Audio Channels for Sources and Destinations



GV Orbit Control routes multiples of 16 audio channels by default. As a result, if you want to send 64 audio channels to a destination, you create four destinations with 16 audio channels each.

An automation shown in the procedure below allows you to add all the Stream's AES67 audio channels to the Multilevel Table in the Logical Device Table at once for AES67 sources and destinations.

To automatically create the AES67 audio channels for sources and destinations

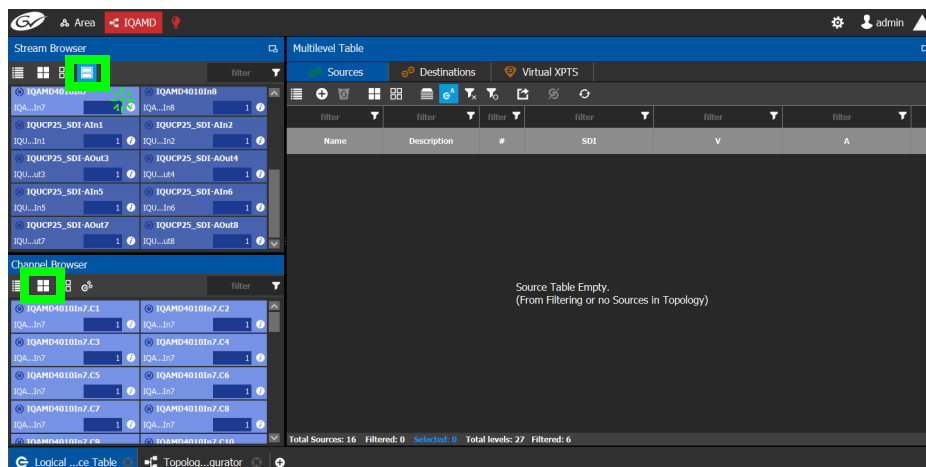
- In the Logical Device Table, Multilevel Table, select the **Sources** tab.
- Select one or more streams in the Stream Browser (using <Ctrl> + click) for which you want to create all the source / destination audio channels.



- Click  to show the Channel Browser in the Stream Browser of the Logical Device Table. See [Stream Browser / Channel Browser](#), on page 73.
- Click  to select all in the Channel Browser.

- Click  automated sources / destinations in the Channel Browser to create the selected streams in the multilevel Table.

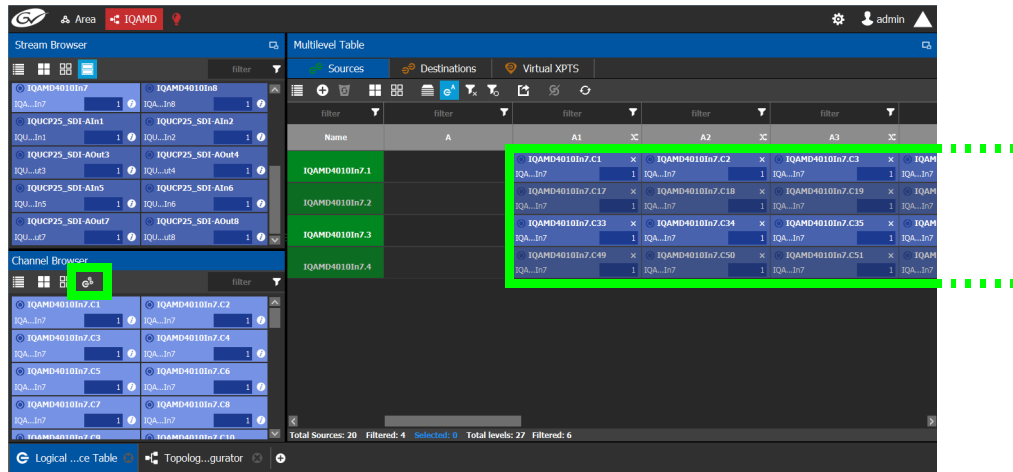

The 64 audio streams are created as four sources / destinations with 16 audio channels each.

- Select the **Destinations** tab and repeat from [step 2](#).
- Test the configuration by making takes between a logical source and destination that use AES67 levels. See [Performing a Take in Router Control](#), on page 290.

5 Monitoring Tasks

Overview

The Monitoring tasks in GV Orbit Control are used to view information about tie line use and the source to destination path of the streams and to monitor the health of the GV Orbit Controllers and the devices in the selected topology.

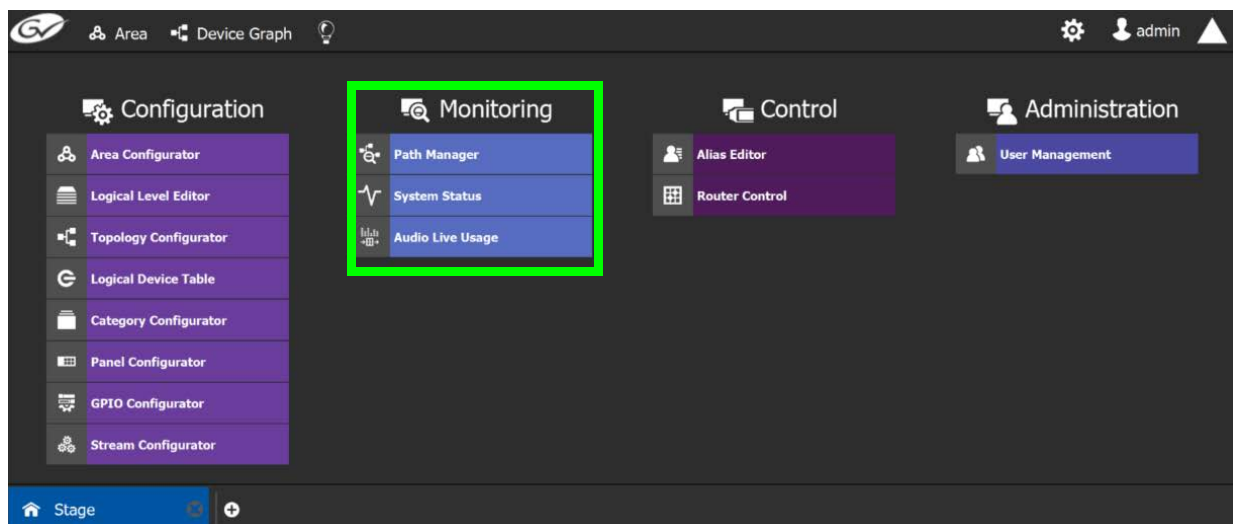

The GV Orbit Control Monitoring Tasks include:

- [Path Manager Tasks](#), on page 270
- [System Status Task](#), on page 277
- [Audio Live Usage](#), on page 282

Path Manager Tasks

Use the Path Manager task to view information about the tie-line use and the source to destination path of the streams. Tie-lines also show the current percentage of bandwidth used.

When a topology includes a DCNM Network Switch, the Path Manager shows:

- Technical information that can be used to help diagnose network connectivity and path issues (no signal or wrong signal at the destination).
- The overall health status of each Network Switch device.

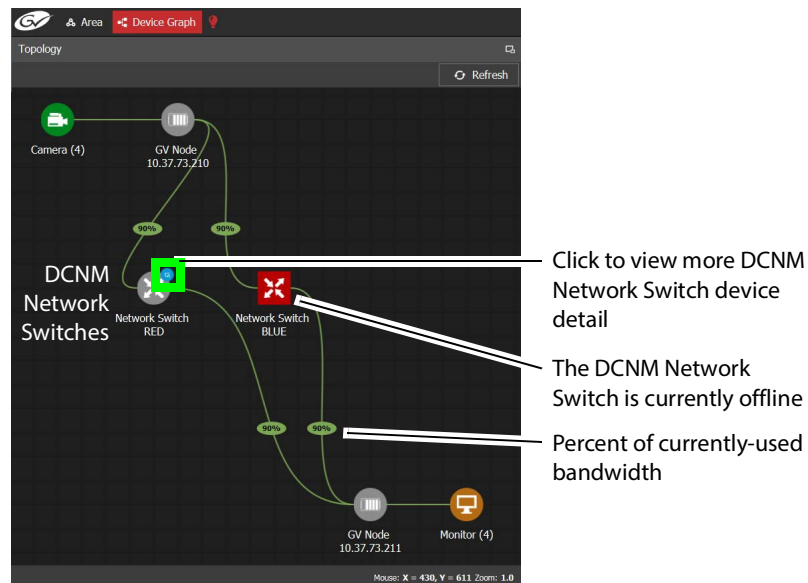

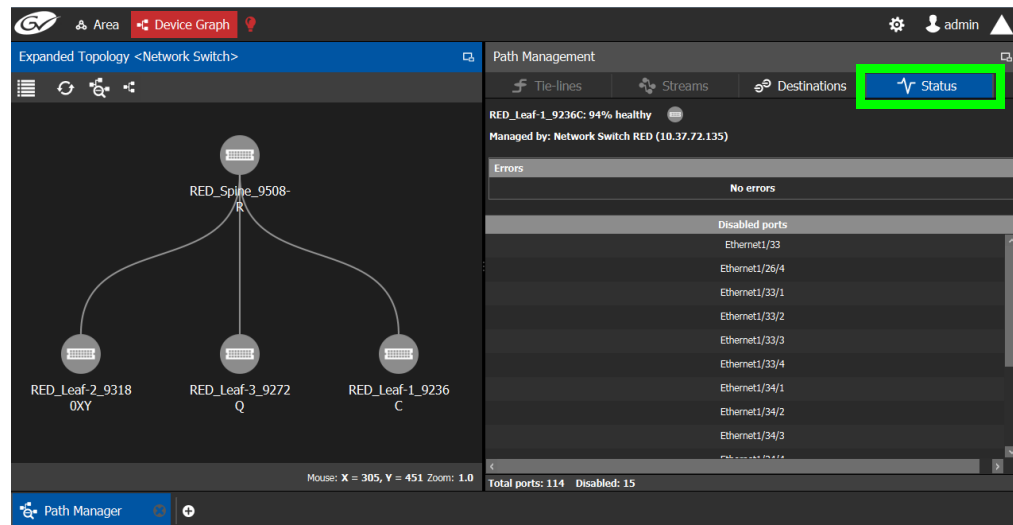

Network Switch devices have a blue bubble that when clicked provides more information about the internal status of the DCNM Network Switch that is shown in the Status tab.



Interpreting DCNM Network Switch Symbols

The following DCNM network switch symbols are used to represent the Network Switch device's health.

Symbol	Description
	The DCNM network switch device is healthy.
	Connection to the DCNM network switch device is offline. To diagnose: Select this device and select the Status tab to view more technical information that can be used to troubleshoot the issue in the DCNM Web interface (by looking at the host policy / flow policy / flow status).

For a system-level health status, see [System Status Task](#), on page 277.

Accessing the Path Manager

To access the Path Manager Task

- 1 Open GV Orbit Control Stage. See [Navigating Back to Stage](#), on page 10.
- 2 Select the required Area. See [Selecting an Area](#), on page 23.
- 3 Select the required topology. See [Selecting a Graph](#), on page 25.
- 4 Make the topology active. See [Activating a Topology](#), on page 66.

5 Select **Monitoring > Path Manager**.

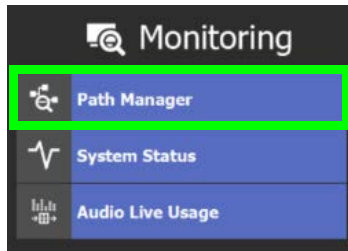

The Path Manager task opens:

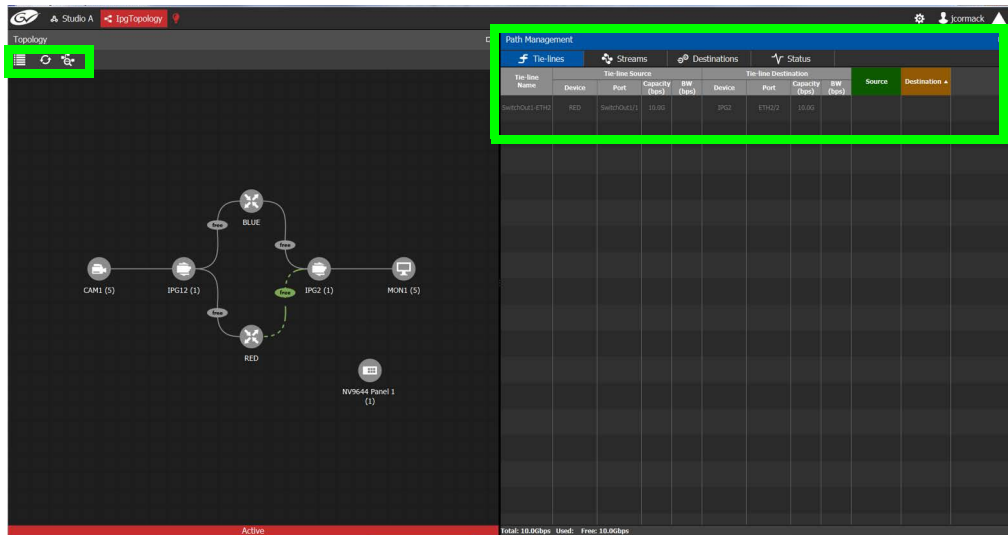

Under Path Management, click any of the following tabs for more information:

- Tie-lines
- Streams
- Destinations
- Status

Path Manager Topology Menu

The Path Manager Topology menu has the following menu options.

Icon	Description
Refresh	Reloads the Topology's contents. See Refreshing the Topology , on page 42.
Overview	Shows the top level of the topology.
Refresh Tielines	Allows you to recompute the tielines usage based on the current crosspoints in each device, in case the tieline status in the control system has become out-of-sync with what is actually routed. During tieline refresh, all tielines are locked and you can not perform any takes. Only use this feature during off hours as this can take up to 30 seconds to complete.

Viewing Information about the Tie-lines

To view information about the tie-lines

- 1 Open the Path Manager for the selected topology. See [Accessing the Path Manager](#), on page 271.
- 2 Click Overview  if available.
The tie-lines show their currently-used capacity in percent.
- 3 Select a tie line in the Topology.

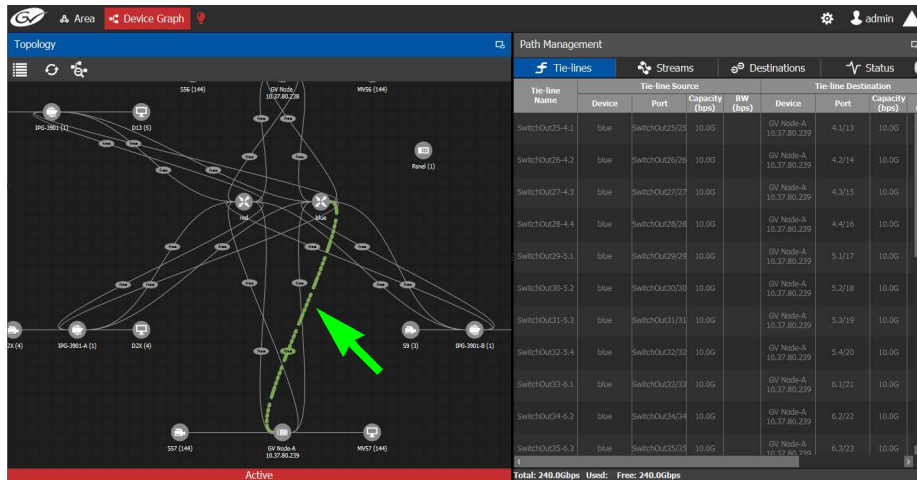

The screenshot shows the Path Management interface. On the left is a network topology diagram with various nodes and connections. A green arrow points to a specific tie line. On the right is a table with the following columns: Tie-line Name, Device, Port, Capacity (bps), BW (bps), Device, Port, Capacity (bps), and BW (bps). The table lists 15 tie lines, all with a Capacity of 10.0G and BW of 10.0G. The status bar at the bottom indicates 'Total: 240.0Gbps Used: 0.0Gbps'.

In the **Tie-lines** tab, the source and destination information is displayed under the following headings:

- Tie line Name
- Tie line Source: Device, Port, Capacity (bps), BW (bps)
- Tie line Destination: Device, Port, Capacity (bps), BW (bps)
- Source
- Destination

Viewing Information about the Streams

To view information about the streams

- 1 Open the Path Manager for the selected topology. See [Accessing the Path Manager](#), on page 271.
- 2 Click Overview  if available.
- 3 Select a tie line in the Topology.
- 4 Select the **Streams** tab.
- 5 In Tie-lines, select a tie-line that you want more information on its streams.

The stream information is displayed under the following headings:

- Stream
- IP address
- BW (bps)
- Source
- Destination

Viewing Information about the Destinations

This tab shows the path for a signal to a destination. If a destination is showing the wrong signal, use this tab to trace the destination signal back to the source or to start fault-finding.

When a topology includes a GV Fabric / DCNM Network Switch, this tab shows operational status information about the path used by a signal to a destination through the GV Fabric / DCNM Network Switches, GV Node senders and receivers for example. When you select a Network Switch device that is in alarm, more information about the internal status of the GV Fabric / DCNM Network Switch is shown in the Status tab.

To view information about the destinations

- 1 Open the Path Manager for the selected topology. See [Accessing the Path Manager](#), on page 271.
- 2 Select the **Destinations** tab.

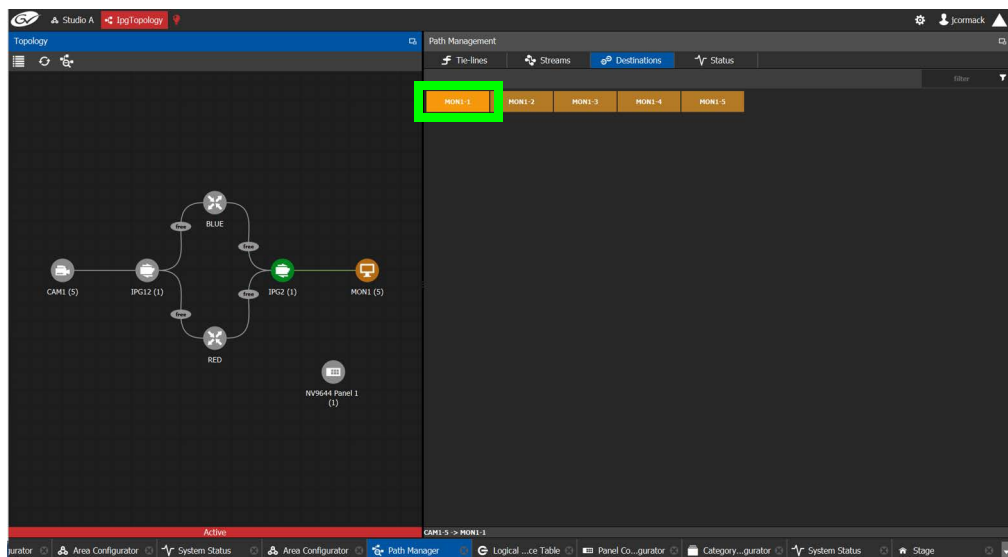

All the destinations are listed on the right.

- 3 Select a destination. The path details to that destination are shown.

If the topology includes a DCNM Network Switch, the path details will include the spine and leaf connections within the DCNM network. This can be used to diagnose issues with the DCNM network switch or any other signal path issue. For example, the figure

below shows that the RED network is in alarm and as such no signal is passing through this part of the switch's fabric.

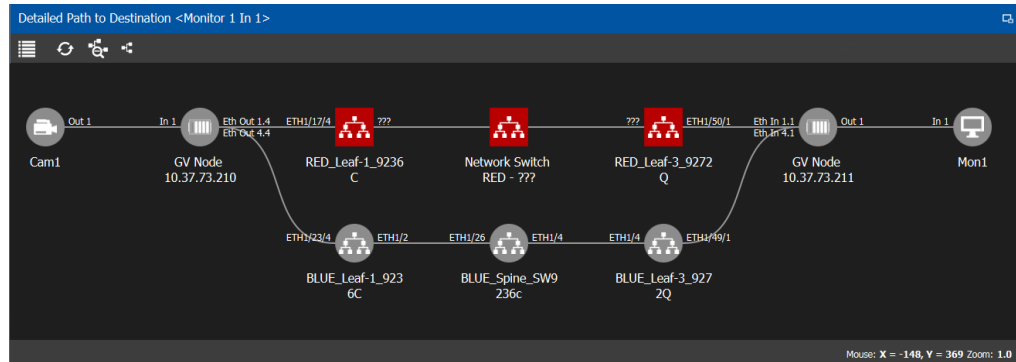

To know more about the DCNM Network switch symbols that are used for health monitoring, see [Interpreting DCNM Network Switch Symbols](#), on page 271

- 4 If a DCNM network switch is in alarm, select it and more specific diagnostic information for the related flow shown under the **Path Management, Status** tab.

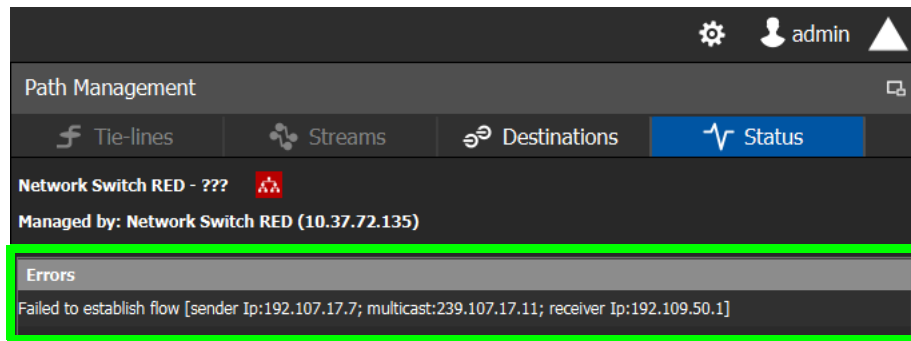

Use this information to diagnose path issues, for example, through the switch's or GV Node's native configuration interface.

- 5 Click **Overview** to view a highlighted path between the source, shown in green, and the destination, shown in brown.

Viewing Information about the Status

When a topology includes a DCNM Network Switch, this tab shows more technical information about the DCNM Network Switches such as the Network Switch device's operational status that can be used to diagnose the issue in the path issue, for example, through the switch's or GV Node's native configuration interface.

To view information about the status

- 1 Open the Path Manager for the selected topology. See [Accessing the Path Manager](#), on page 271.
- 2 Select the **Status** tab.

The flow status of the DCNM Network Switches are displayed, if applicable.

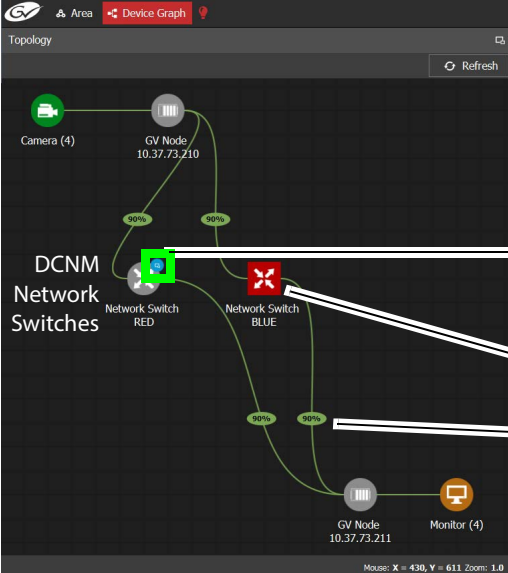

Click to view more DCNM Network Switch device detail

The DCNM Network Switch is currently offline

Percent of currently-used bandwidth

Network Switch devices have a link  that when clicked shows the exploded network switch showing more information about spine and leaves, and the bandwidth capacity for each specific link.

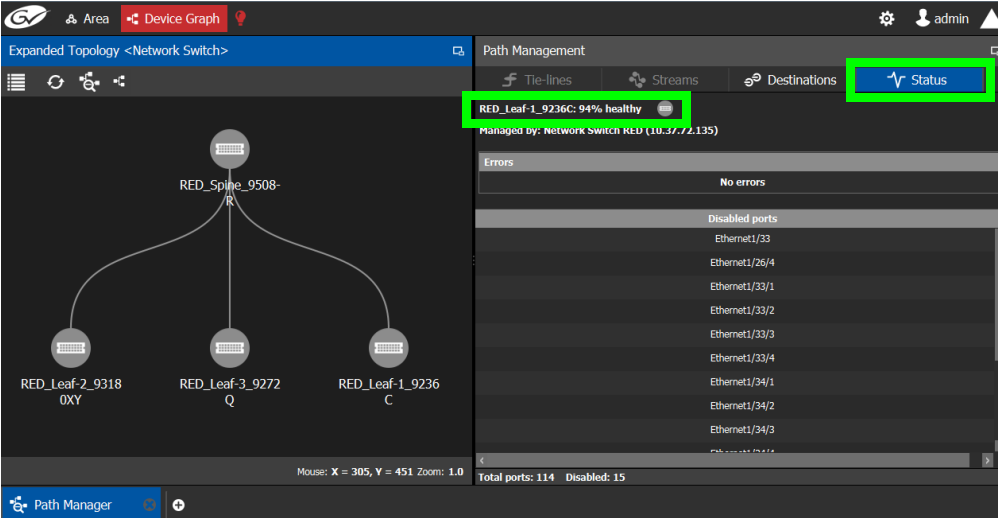

Disabled ports	
Ethernet1/33	
Ethernet1/26/4	
Ethernet1/33/1	
Ethernet1/33/2	
Ethernet1/33/3	
Ethernet1/33/4	
Ethernet1/34/1	
Ethernet1/34/2	
Ethernet1/34/3	
Ethernet1/34/4	

Total ports: 114 Disabled: 15

Click each switch to see its health of the switch (as report by the switch itself).

Disabled Ports shows a list of all the switch's disconnected or unused ports that are currently disabled by the switch.

System Status Task

Use the System Status Task to monitor the health of the GV Orbit Controllers and the devices in the selected topology. You can also perform a manual failover from this task.

Accessing the System Status Task

To access the System Status Task

- 1 Open GV Orbit Control Stage. See [Navigating Back to Stage](#), on page 10.
- 2 Select the required Area. See [Selecting an Area](#), on page 23.
- 3 Select the required topology. See [Selecting a Graph](#), on page 25.
- 4 Select **Monitoring > System Status**.

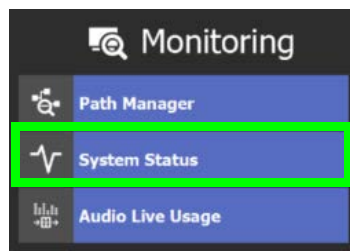

The System Status task opens:

A screenshot of the 'System Status' task interface. The interface is dark-themed and shows two main sections: 'GVC Controllers' and 'Devices'.
GVC Controllers: A table with columns for Parameters, GVC Controller 1, and GVC Controller 2. The 'Status' row shows Controller 1 as 'Active' and Controller 2 as 'Inactive' with a 'Force Active' button. The 'Health' row shows green progress bars for both. The 'CPU' row shows 0% usage for both. The 'Actual Memory' row shows 42% usage for both. The 'Reserved Memory' row shows 2% usage for both. The 'Network Interface' row shows 'eth0' and 'eth1' for both.
Devices: A table with columns for Name, GVC Controller 1, and GVC Controller 2. The 'BLUE' device is 'Active' on Controller 1 and 'Standby' on Controller 2. The 'RED' device is 'Active' on Controller 1 and 'Standby' on Controller 2. A 'Network Switch-B' device is 'Unknown' on both controllers.
At the bottom of the interface, there is a 'System Status' button with a pulse icon.

In this configuration, Controller 1 is the active controller and Controller 2 is not present. The System Status task displays the following information for both GV Orbit Control controllers: **GVC Controller 1** and **GVC Controller 2**. Depending on the server

hardware model and the software applications that are currently installed, certain status parameters shown in the table below will not be displayed.

Parameter	Description
IP	The current controller's IP address.
Status	The current status of GV Orbit Control GVC Controller 1 and GVC Controller 2 (if equipped): Active: All GV Orbit Control task are being processed by this controller. Inactive: This controller is in hot standby. It is ready to take over from the active controller. Force Active: Make this controller the active controller. See Forcing the Inactive Controller to be the Active Controller , on page 279.
Health	The current controller's health metric: Green bar: Indicates that the controller's overall health is good. Red Bar: Indicates an issue requires attention / maintenance actions.
ID	Identifies the members of a cluster: 1: The server that the administrator logged in to when creating the cluster. This is the <i>first</i> server of the cluster. 2: The <i>second</i> server that was added by an administrator who was logged in to the first server when creating the cluster.
CPU and Memory	The current GV Orbit Server's CPU and memory usage show the current level of activity.
CPU and Memory	The current controller's CPU and memory usage show the current level of controller activity.
Fans	The current controller's cooling fan health: A green box indicates that the controller's fans are operating correctly.
PSU	Green: the PSU is plugged and detects power. Red: the PSU doesn't detect power. Possibly the power cable is unplugged. Gray or no status: the server doesn't detect correctly the PSU unit because the unit is physically removed or the initialization isn't done. In this second case, shutdown the server, disconnect both power cables, physically remove both power supply units, re-insert them both and apply power to both. Then start the server.
Network Interface	The current controller's Ethernet interface names and health: A green box indicates that the controller's Ethernet interfaces are operating correctly.
Panels Communications Status	Shows the network connection status between the GV Orbit Server and the panel that have been configured in GV Orbit Control.

Parameter	Description
Devices	The current status of the devices: Active: This device is in active operation. Standby: This device is in hot standby. It is ready to take over from the active device. Primary / Secondary: When a cluster of Audio Live devices are configured for redundancy, this shows the IP addresses and the health of those devices. See also Audio Live Redundancy Support , on page 260.
Faults	A list of any current faults.

For more information about the health status of a DCNM Network Switch device, see [Path Manager Tasks](#), on page 270.

Forcing the Inactive Controller to be the Active Controller

If two controllers are configured in a redundant configuration, then during the normal course of operations, one controller is active and the other is inactive at all times.

If a problem occurs, such as network loss or connectivity issues, the inactive controller (Controller 2) becomes the active controller. The controller that was formerly active (Controller 1) reboots. This is an automatic failover. You can perform a manual failover if you have administrator rights in the selected Area. See [Viewing Permissions by Role](#), on page 304.

To perform a manual failover

- 1 Open the System Status task for the required topology. See [Accessing the System Status Task](#), on page 277.

Parameters	GVC Controller 1	GVC Controller 2	Name	GVC Controller 1	GVC Controller 2
IP	10.37.72.107	10.37.72.111	BLUE	Active	Standby
Status	Active	Inactive Force Active	GV Node 10.37.73.210 IFM-2T Gateway	Active	Standby
Health			GV Node 10.37.73.210 Router	Active	Standby
ID	1	1	GV Node 10.37.73.211 IFM-2T Gateway	Active	Standby
CPU	0%	0%	GV Node 10.37.73.211 Router	Active	Standby
Actual Memory	42%	42%	Network Switch-B	Unknown	Unknown
Reserved Memory	2%	2%	RED	Active	Standby
Fan				Active : 10.37.72.133 Standby : 10.37.72.134 HA Status : OK	
Network Interface	eth0 eth1	eth0 eth1			
Faults					

- 2 Click the **Force Active** button for the Inactive Controller.

A confirmation message appears.

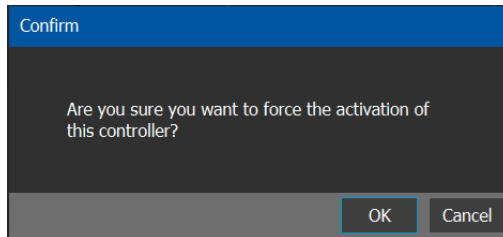

3 Click **OK** to continue.

The controllers switch states. The formerly inactive controller (Controller 2) becomes active. The formerly active controller (Controller 1) reboots. As it shuts down, the following changes occur and are reflected on the System Status task.

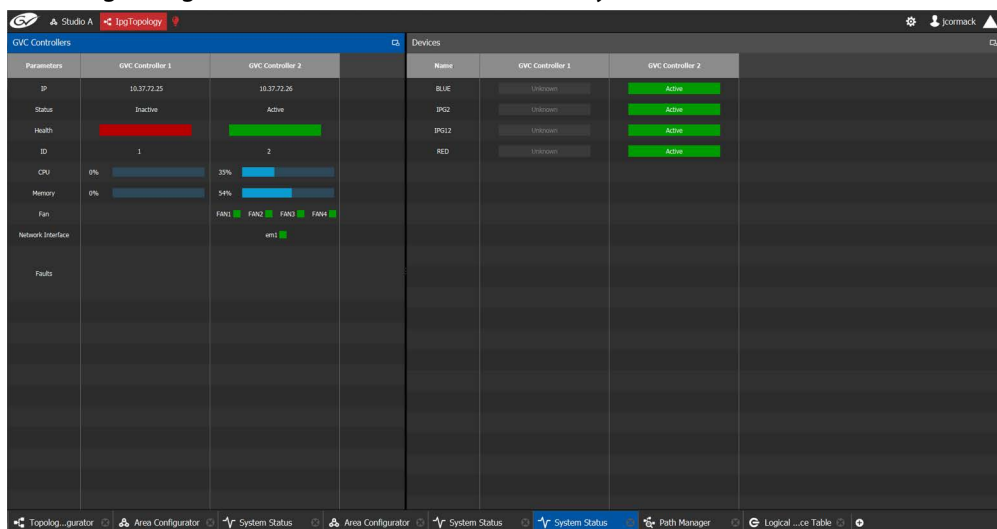

- The **Status** of the **Controller 1** is now **Inactive**.
- A **red bar** is displayed for the **Health** of Controller 1, indicating it is not good.
- The **CPU** and **Memory** are at **0%**.
- The **Fans** and **Network Interface** are blank.
- The **Status** of the **Controller 2** is now **Active**.
- A **green bar** is displayed for the **Health** of Controller 2, indicating it is good.
- The **CPU** and **Memory** fields show their level of activity.
- The **Fans** are green, indicating health.
- The **Network Interface** displays the Management Interface port name (em1).
- The status of all **devices** controlled by **Controller 1** is **unknown**.
- The status of all **devices** controlled by **Controller 2** is **active**.

When Controller 1 comes back, the following changes occur and are reflected in the interface.

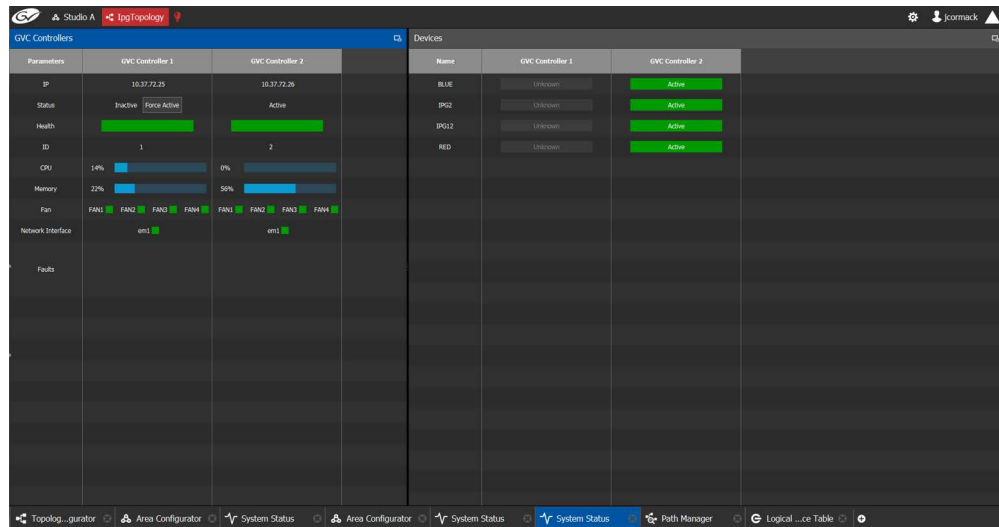

- The **status** of **Controller 1** is now **Inactive**.
- The **health** field for Controller 1 displays a **green bar** indicating it is good.
- The **CPU** and **Memory** fields for both controllers show the current level of activity.
- The **fans** for both controllers show **green** boxes indicating health.
- The **Network Interface** port of both controllers is displayed, **em 1**.
- The **status** of the devices on **Controller 1** is **unknown**.
- The **status** of the devices on **Controller 2** is **active**.

Finally, when Controller 1 is fully rebooted, the following changes occur:

- The **status** of the devices on **Controller 1** is **standby**.

Permissions

Only users who are assigned to Administrators role in the selected area have View, Edit, and Delete permissions in the System Status task. Users who are assigned to Engineers, Operators, and Maintenance roles have view rights only. See [Viewing Permissions by Role](#), on page 304.

Audio Live Usage

Use the Audio Live Usage Task to have more information about the loading and use of an Audio Live's capacity. This is a debugging tool to help you to better understand what the Audio Live's routing capacity.

PREREQUISITES: One or more Audio Live devices must have been configured on the current topology. See [Configuring an IQAMD40 Device](#), on page 265.

Accessing the Audio Live Usage Task

To access the Audio Live Usage Task

- 1 Open GV Orbit Control Stage. See [Navigating Back to Stage](#), on page 10.
- 2 Select the required Area. See [Selecting an Area](#), on page 23.
- 3 Select the required topology. See [Selecting a Graph](#), on page 25.
- 4 In the Topology Configurator, activate the topology. See [Activating a Topology](#), on page 66.
- 5 Select **Monitoring > System Status**.

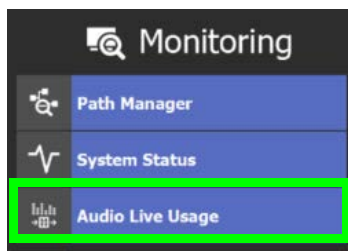

The Audio Live Usage task opens:

Audio Live Name	64ch Input Usage	16ch Input Usage	8ch Input Usage	4ch Input Usage	64ch Output Usage	16ch Output Usage	8ch Output Usage	4ch Output Usage
AL220	0%	0%	0%	0%	0%	0%	0%	0%
AL221	0%	0%	0%	0%	0%	0%	0%	0%

Spigot Name	Channel Capacity	Direction	Timeline Status	Multicast IP	Sources	Destinations
Ip Spigot 1	64	Input	Free	225.1.1.1		
Ip Spigot 2	64	Input	Free	225.2.1.1		
Ip Spigot 3	64	Input	Free	225.3.1.1		
Ip Spigot 4	64	Input	Free			
Ip Spigot 5	64	Input	Free			
Ip Spigot 6	64	Input	Free			
Ip Spigot 7	64	Input	Free			
Ip Spigot 8	64	Input	Free			
Ip Spigot 9	16	Input	Free	225.1.1.1		
Ip Spigot 10	16	Input	Free	225.2.1.1		
Ip Spigot 11	16	Input	Free	225.8.1.1		
Ip Spigot 12	16	Input	Free	225.32.1.1		
Ip Spigot 13	16	Input	Free	225.38.1.1		
Ip Spigot 14	16	Input	Free			
Ip Spigot 15	16	Input	Free			

All table columns can be filtered. See [Filtering Lists, Table Columns, Sources, and Destinations](#), on page 97.

Icon	Description
 Refresh	Reloads the Audio Live Usage task contents. If you make a Take for audio streams through an Audio Live device, then you must click Refresh to see the results.
Audio Live Name	The device name configured for the Audio Live device, in the device's properties.
64ch Input Usage	The number of AES67-64 input levels currently being used out of the available number of AES67-64 input levels, expressed as a fraction.
16ch Input Usage	The number of AES67-16 input levels currently being used out of the available number of AES67-16 input levels, expressed as a fraction.
8ch Input Usage	The number of AES67-8 input levels currently being used out of the available number of AES67-8 input levels, expressed as a fraction.
4ch Input Usage	The number of AES67-4 input levels currently being used out of the available number of AES67-4 input levels, expressed as a fraction.
64ch Output Usage	The number of AES67-64 output levels currently being used out of the available number of AES67-64 output levels, expressed as a fraction.
16ch Output Usage	The number of AES67-16 output levels currently being used out of the available number of AES67-16 output levels, expressed as a fraction.
8ch Output Usage	The number of AES67-8 output levels currently being used out of the available number of AES67-8 output levels, expressed as a fraction.
4ch Output Usage	The number of AES67-4 output levels currently being used out of the available number of AES67-4 output levels, expressed as a fraction.

6 Select an Audio Live device from the list. Detailed spigot information is shown under **Spigot Information**.

Icon	Description
Spigot Name	The name configured for this spigot, in the device's properties.
Channel Capacity	The number of AES-67 channels supported by the spigot.
Direction	Shows the signal direction for this spigot. Input: The spigot is a destination from another device. Output: The spigot is a source to another device.
Tieline Status	Shows this spigot's current connection status. Free: There is no device connection for this spigot. Busy: The tieline is connected to another device. Exposed: Indicates that the spigot's stream is exposed.

Icon	Description
Multicast IP	Shows the current multicast IP address that is joined to this spigot. For an Input, this is the source multicast IP address that the Audio Live is connected to. For an Output, this is the Audio Live source multicast IP address that a destination device connects to.
Sources	Shows the current name of the source(s) connected to the input.
Destinations	Shows the current name of the destination(s) connected to the output.

Columns in the **Spigot Information** table can be multi-sorted, the same way the Stream Configurator List can be sorted. See [Sorting the Stream Configurator List](#), on page 156.

6 Control Tasks

Overview

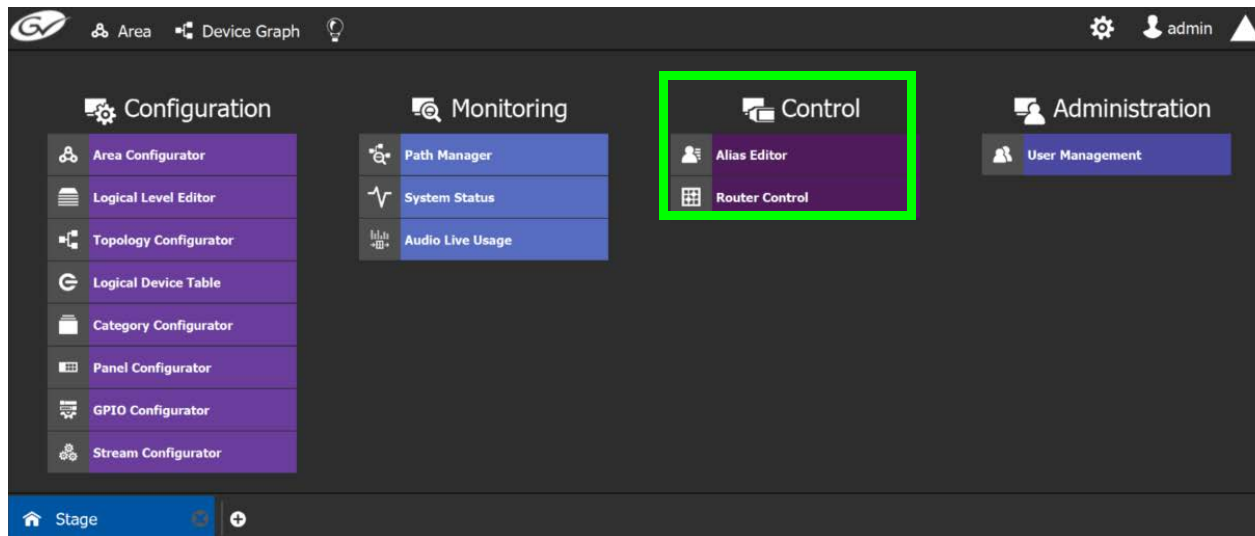

The GV Orbit Control Tasks include:

- [Alias Editor Tasks](#), on page 286GV Orbit Client
- [Router Control Tasks](#), on page 289

Alias Editor Tasks

Use the Alias Editor to assign aliases to sources and destinations. More than one set of aliases can be created to allow the source / destination naming conventions to be changed on the fly, for example, to change the interface for different programs or production staff, or to support another language(s).

Accessing Alias Editor Tasks

To access the Alias Editor

- 1 Open GV Orbit Control Stage. See [Navigating Back to Stage](#), on page 10.
- 2 Select the required Area. See [Selecting an Area](#), on page 23.
- 3 Select the required topology. See [Selecting a Graph](#), on page 25.
- 4 Select **Control > Alias Editor**.

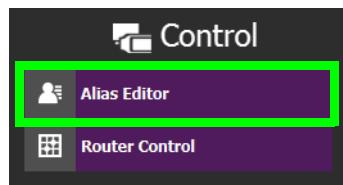



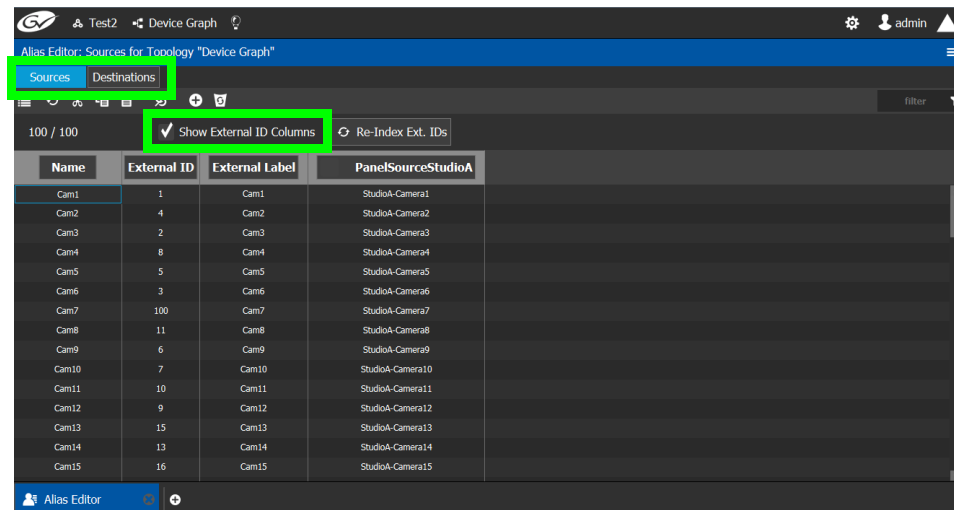

The Alias Editor task opens.





The Alias Editor has tabs for Source and Destination IDs.

Alias Editor Menu

The Alias Editor menu has the following menu options.

Icon	Description
 Refresh	Reloads the Alias Editor's contents.
 Cut	Cuts the selected contents from an alias column.
 Copy	Copies the selected contents from an alias column.
 Paste	Pastes the clipboard contents to the alias column.

Icon	Description
 Restore default label	When a selected alias has been renamed, this resets the name to its original label.
 New	Adds an alias column. See Adding Aliases , on page 287.
 Delete	Removes the selected alias column.

In order to protect against an erroneous click, a captcha-style dialog requires that you confirm this action which can have a large impact on router tables.

Adding Aliases

These aliases can be used in router control to change the name of sources and destinations from short labels to the labels of the corresponding alias. The alias can be composed of up to 24 characters to create a more descriptive name than its equivalent short label. Aliases can also be used with panels; see [Creating a New Panel](#), on page 107. See also [Using Source and Destination Aliases with a Panel](#), on page 121.

Once an alias column has been added, you can also copy/paste a list of values from an Microsoft Excel spreadsheet column into the alias column to bulk name the sources and destinations.

Aliases created here can be selected in GV Orbit Control’s user interface where sources and destinations are used with the **Select Alias** option. For example, in the Category Configurator; see [Category Configurator Tasks](#), on page 98.

To Add Aliases

- 1 Open the Alias Editor. See [Accessing Alias Editor Tasks](#), on page 286.

The Alias Editor task opens.

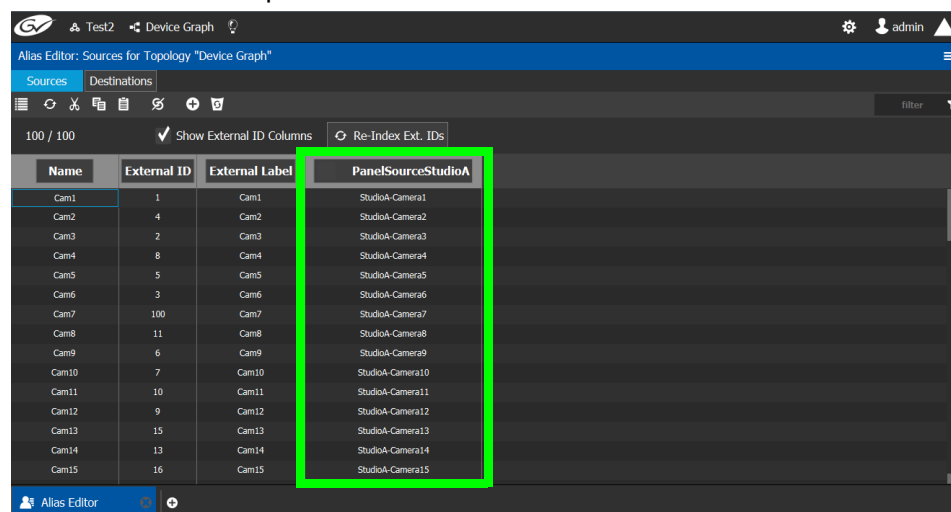

The Alias Editor has tabs for Source and Destination IDs.

- 2 Select **Show External ID Columns** columns if necessary.

The aliases are now available to be used with router control and panels. If aliases are used with a panel and they are longer than 8 characters, consider setting the **Display 24 characters** option for the panel in the Panel’s **Property Editor**. See [Creating a New Panel](#), on

page 107. The alias to be used in the Category Configurator can be selected; see [Sources & Destinations Menu](#), on page 99.

Renaming Source and Destination Labels

Source and destination labels can be renamed. You can also copy/paste a list of values from an Microsoft Excel spreadsheet column into the **Name** or Alias columns to bulk rename the sources and destinations. Or you can copy the content of one column and paste it into another column.

To rename Source and Destination Labels

- 1 Open the Alias Editor. See [Accessing Alias Editor Tasks](#), on page 286.

The Alias Editor task opens.

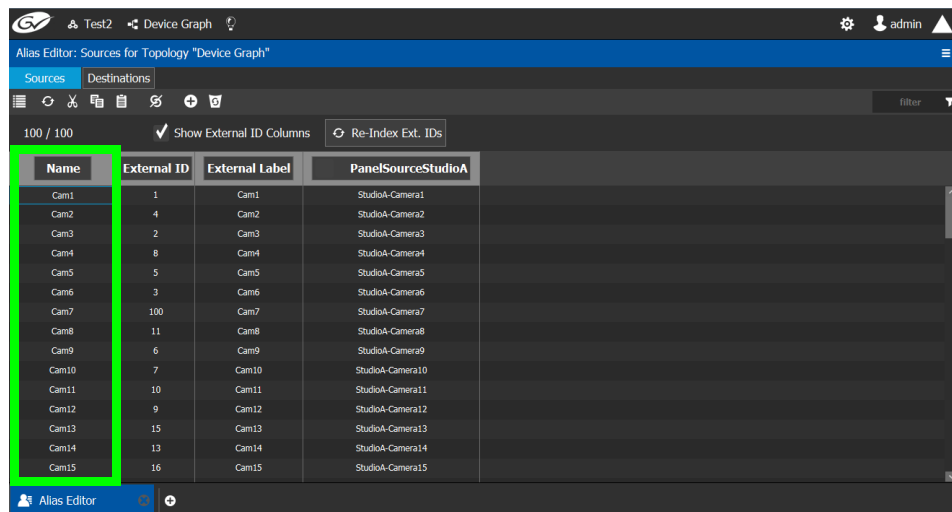

The Alias Editor has tabs for Source and Destination IDs.

- 2 Rename the source or destination by slow clicking it twice. Or paste a list of names from an Microsoft Excel spreadsheet column into the **Name** or Alias column to bulk rename them.

Router Control Tasks

Use the Router Control task to control the sources and destination in an active topology.

Accessing the Router Control Task

To access the Router Control task

- 1 Open GV Orbit Control Stage. See [Navigating Back to Stage](#), on page 10.
- 2 Select the required Area. See [Selecting an Area](#), on page 23.
- 3 Select the required topology. See [Selecting a Graph](#), on page 25.
- 4 Select **Control > Router Control**.

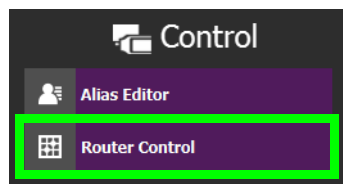

The Router Control task opens

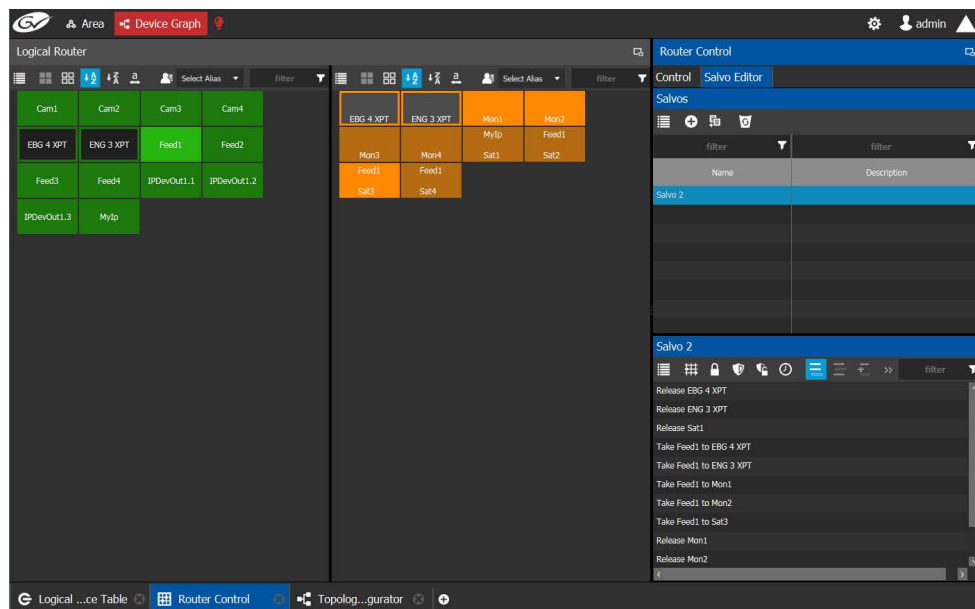





The sources are listed on the left under Logical Router. The destinations are listed in the center. The right hand column displays the actions you can perform.

Router Control Menu

The Router Control menu has the following menu options.

Icon	Description
	Select All
	Clear All
	Sort Ascending
	Selects all source or destination items.
	Deselects all source or destination items.
	Sort the source or destination items in alphabetical order from A to Z.

Icon	Description
 Sort Descending	Sort the source or destination items in alphabetical order from Z to A.
 Use Wide Widgets	Doubles the source or destination display width to accommodate longer labels. This option setting is remembered for the currently logged in user on the current client PC.
 Select Alias	Select the Alias you want to use to identify Source and Destination streams in GV Orbit Control's interface.  Aliases are created in the Alias Editor. See Adding Aliases , on page 287.

Performing a Take in Router Control

You can perform a take in Router Control as follows.

- 1 Under **Logical Router**, select a source, shown in green.
- 2 Select a destination, shown in brown.
- 3 Under **Router Control**, **Control** tab, click **Take**.

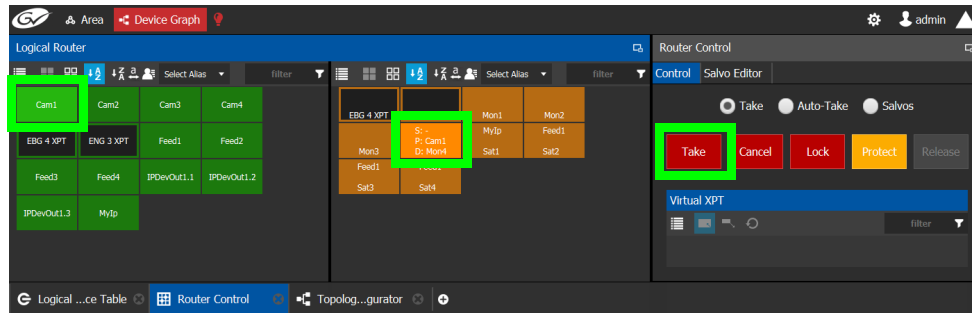

Parameter	Description
Take / Auto-Take / Salvos radio buttons	Sets the router control mode: <ul style="list-style-type: none"> Take: Once the source and destination has been selected, you then click Take to make the take. Auto-Take: Once the source and destination has been selected, the take is automatically made. Salvos: Trigger previously-configured salvos. See also Creating Salvos, on page 293.
Take button	Makes the connection between the currently selected source and destination. In salvo mode, it triggers the selected salvo.
Cancel button	Cancels the current selection.
Lock button	Will lock the current destination to not allow the source to be changed by any user. High Tally when enabled on selected destination. See also About Lock, Protect, and Release , on page 291.
Protect button	Will protect the current destination to not allow the source to be changed by a user other than the current user. High Tally when enabled on selected destination.
Release button	Releases lock or protect on the selected destination.
Virtual XPT > Minimize Virtual XPT ^a	To minimize the destinations within the selected virtual XPT ^b .
Virtual XPT > Expand Virtual XPT ^a	To show all the destinations within the selected virtual XPT, including the nested destinations of all other virtual XPTs ^b .
Virtual XPT > Reset XPT ^a	Initialize the selected virtual XPT. This will route the appropriate virtual source to the logical destinations that were configured for the virtual XPT in the logical device table.

a. This becomes available when virtual XPTs have been previously configured (see [Configuring Virtual Crosspoints \(XPTs\)](#), on page 88). You must select a destination that is part of a virtual destination in the router control grid or select a virtual destination in the router control grid.

b. See [Minimize and Expand Virtual XPT Destinations](#), on page 95 for more information.

About Lock, Protect, and Release

The following topics provide a detailed look at how GV Orbit Control manages Lock, Protect, and Release.

LIMITATIONS:

- iControl matrices do not support protect.

- Lock and protect currently affects all levels of the destination and does not consider individual levels. Locking one level locks all destination levels and the control system does not currently support specific lock levels.

Ability to Override a Lock or Protect according to User Rights

When logged in to GV Orbit Control, the permissions assigned to your user profile determine whether you can override a Lock or Protect made by other users. For example, when a user has *admin* or *Operator* rights, the user can override any lock or protection made by:

- Any other user. See [Viewing Permissions by Role](#), on page 304.
- A third-party control system that uses NP0017 to control GV Orbit Control.
- A third-party control system that placed a lock on a device which is also controlled by GV Orbit Control and for which *in router lock and protect* is enabled. See [About In router Lock/Protect enabled for a Router using NP0016 router control protocol](#), on page 248.
- A panel used to set a lock.

Otherwise, without *admin* or *Operator* rights, you will not be able to override a Lock or Protect set by other users.

See [Administration Tasks](#), on page 297 for more information about how to create users and how to set a user's permissions to allow or deny them from overriding a Lock or Protect set by another user. The following user permissions control the ability to override a Lock or Protect.

- Force Unlock
- Force Unprotect

For example, the admin user has the user permissions for both Force Unlock and Force Unprotect. Therefore, an admin user can override any other user who has set a Lock or Protect on a destination.

Using a Panel to Override a Lock or Protect

If a configured panel in GV Orbit Control is used, a user must be assigned to it. Assign a user to a panel through the **Panel User** parameter (see [Adding the New Panel to the Topology](#), on page 129). It is the user rights that are associated to the user selected in the **Panel User** parameter that determines the panel's priority to override a lock or protect made by another panel user. This can be used to prevent other users from being able to remove a lock. When the **Panel User** parameter is set to a user that has *admin* or *Operator* rights, the panel can be used to override any lock or protection made by:

- Any other user. See [Viewing Permissions by Role](#), on page 304.
- A third-party control system that uses NP0017 to control GV Orbit Control.
- A third-party control system that placed a lock on a device which is also controlled by GV Orbit Control and for which *in router lock and protect* is enabled. See [About In router Lock/Protect enabled for a Router using NP0016 router control protocol](#), on page 248.
- Another panel used to set a lock.

Identifying the User who has Locked a Destination

To see who has locked a destination, try to make a take to the destination in the *Router Control* task. See [Router Control Tasks](#), on page 289. The user locking / protecting the destination is then shown in the lower left corner. If the user is *admin*, then this could be the result of a third-party control system having locked or protected a destination in the router.

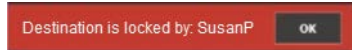

How is Lock, Protect, and Release Implemented?

The router protocol and the GV Orbit Control's router control port configuration can affect how the Lock, Protect, and Release are implemented. For a further explanation, refer to the router protocol you are using.

Router Control Protocol	See
NP0016 Compact Router	About In router Lock/Protect enabled for a Router using NP0016 router control protocol , on page 248
NP0016 Enterprise Router	
NV9000 TCP/IP (NP0017 southbound)	Lock, Protect, and Release with the NV9000 Control Port , on page 250
NP0016 Enterprise Router	Lock, Protect, and Release with the NP0016 / NS-Bus / SAM SW-P-08 Control Ports , on page 293
NS-BUS	
SAM SW-P-08 TCP/IP	

Lock, Protect, and Release with the NP0016 / NS-Bus / SAM SW-P-08 Control Ports

GV Orbit Control stores the locks in its database and they are preserved after a restart/reboot. As such, destinations will remain locked/protected. GV Orbit Control system does not read a lock from a router and does not control a lock in the router.



Creating Salvos

When a salvo is triggered, it executes a list of pre-configured actions. You can create a salvo as follows.

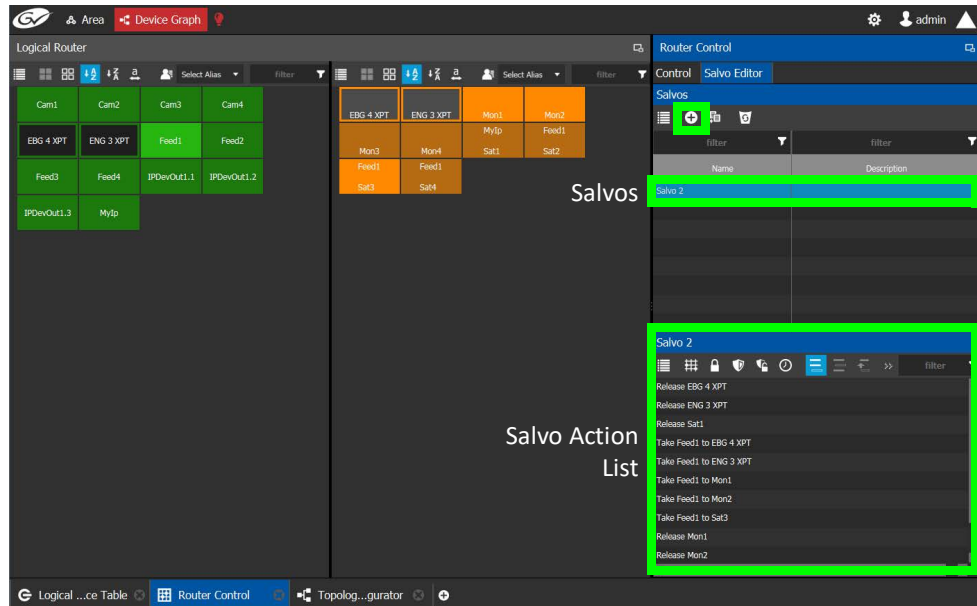
- 1 Under **Router Control, Salvo Editor** tab, click **New** .
- 2 Enter a name and description for the salvo in the **Salvos** list.



Icon	Description
	New Create a new salvo and associated salvo action list.
	Duplicate Make a copy of the currently-selected salvo.
	Delete Remove the currently-selected salvo / take.
	Take Add the currently-selected source and destination as a take action to the salvo list. The following functional behaviors are by design: <ul style="list-style-type: none"> • If multiple destinations are selected, then there will be multiple take actions added to the salvo list. • If there is only one source and multiple destinations selected, then that source is routed to all destinations. • If multiple sources are selected (for example, Source1, Source2, Source3) and multiple destinations are selected (for example, Destination1, Destination2, Destination3, and Destination4), then the takes added to the salvo list are Source1 to Destination1, Source2 to Destination2, Source3 to Destination3.
	Lock Lock the currently selected destination. See also About Lock, Protect, and Release , on page 291.
	Protect Protect the currently selected destination.
	Release Release the currently selected destination.
	Pause The wait time in milliseconds that can be added to the list of operations.
	Append In this mode, any new salvo operation will be added to the end of the salvo action list.
	Insert In this mode, any new salvo operation will be inserted at the currently selected spot in the salvo action list.

Icon	Description
	Replace In this mode, any new salvo operation will replace the currently-selected salvo action from the salvo action list.
	Move Up Move the selected salvo action up in the salvo action list.
	Move Down Move the selected salvo action down in the salvo action list.

- 3 Under **Logical Router**, select a source, shown in green.
- 4 Select a destination, shown in brown.
- 5 Under the salvo action list, click **Take**.

Selecting the Name of Sources and Destinations

When a source or destination has been assigned an alias, you can select the alias to be shown through the Alias drop-down menu. To create aliases, see [Alias Editor Tasks](#), on page 286.

- 1 Select a source or destination under **Logical Router**.
- 2 Click the alias drop-down menu and select an alias option.

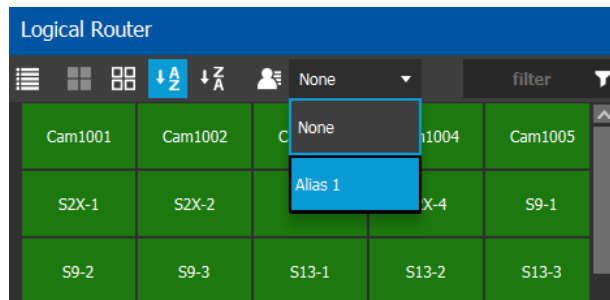

The label for the selected source or destination changes to the selected option.

7 Administration Tasks

User Management is the only Administration task. Only administrators have access to it.

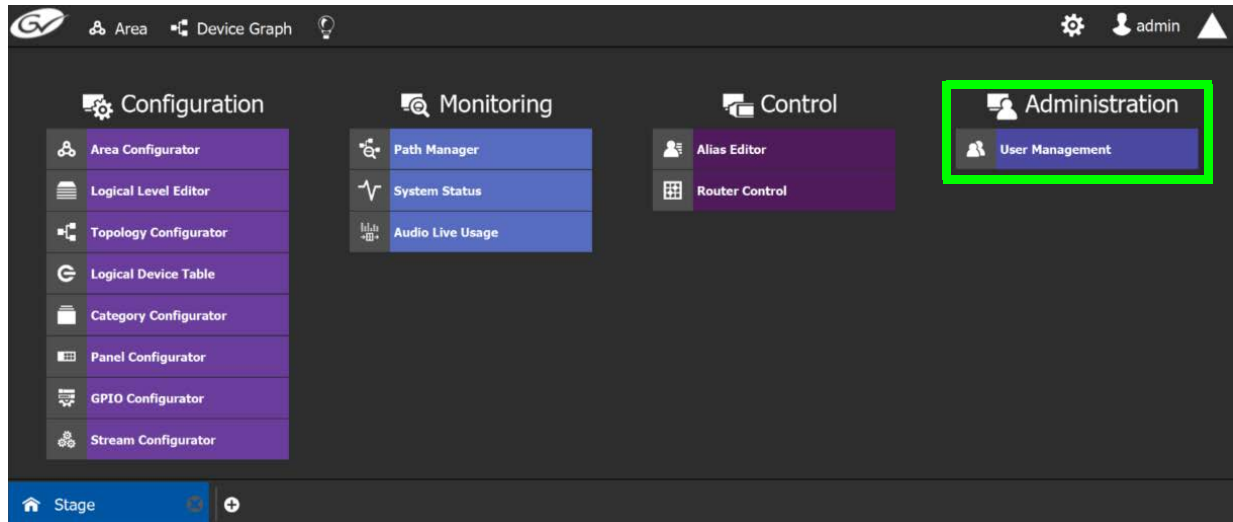

User Management Task

As an administrator, you have access to the User Management Task. This is used for:

- Creating, editing, and deleting user profiles. See [Creating User Profiles](#), on page 299.
- Managing access rights to the areas in your system. See [Granting Access Permissions to an Area](#), on page 301.
- Viewing and assigning permissions according to predefined user roles. See [Viewing Permissions by Role](#), on page 304.

The User Management Task Overview

Note: Before you assign access permissions, you must create areas in your system. For details, see [Area Configurator Tasks](#), on page 17.

When you first log in to the User Management Task, the admin tile appears in the **Users** section.

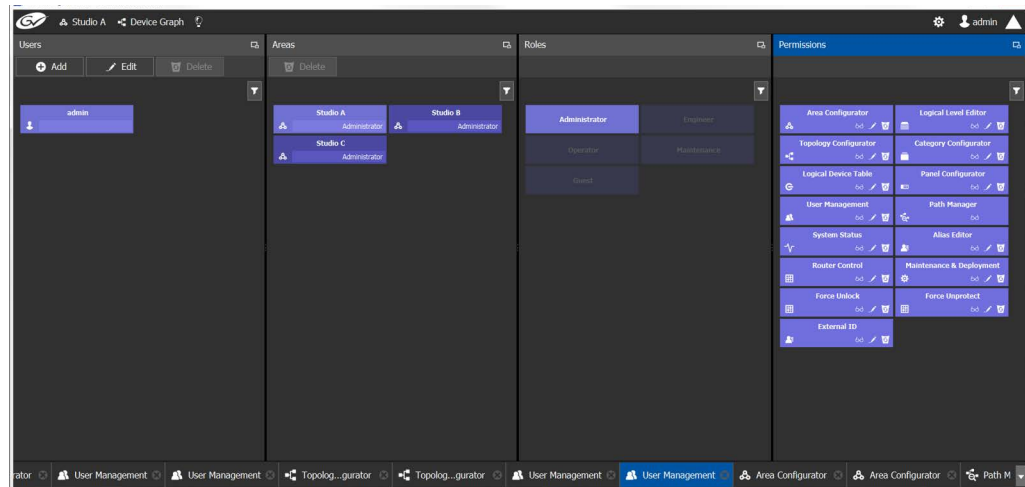

The User Management Task UI has four columns:

- **Users:** The column displays a tile for each user who has access to your system. See [Creating User Profiles](#), on page 299.
- **Areas:** The column displays a tile for each area defined in your system. See [Granting Access Permissions to an Area](#), on page 301.
- **Roles:** The column displays a tile for each of the predefined roles: Administrator, Engineer, Operator, Maintenance, and Guest. Permissions to view, edit, and delete within each client task vary by role. These permissions can be seen when you select the role in the Roles column; for example, **Administrator** is selected in the screen shot above. The permissions granted to the administrator role are shown in the **Permissions** column. (Members of the administrator role have full access permissions to all areas in the system). See [Viewing Permissions by Role](#), on page 304 for a list of the permissions available to each role.
- **Permissions:** The column displays a tile for the tasks that users can perform within the areas in your system according to the selected User, Area, and Role. View, edit and delete icons show the current user's rights for the task.

Creating User Profiles

The first step is to create your user profiles.

Note: To access the user profiles, you must belong to the administrator role. Otherwise, Administration tasks are not visible in GV Orbit Control Stage.

To create a new user account:

- 1 Launch GV Orbit Control.
- 2 Log in as an administrator.
- 3 Select **Administration > User Management**.

The User Management window appears.

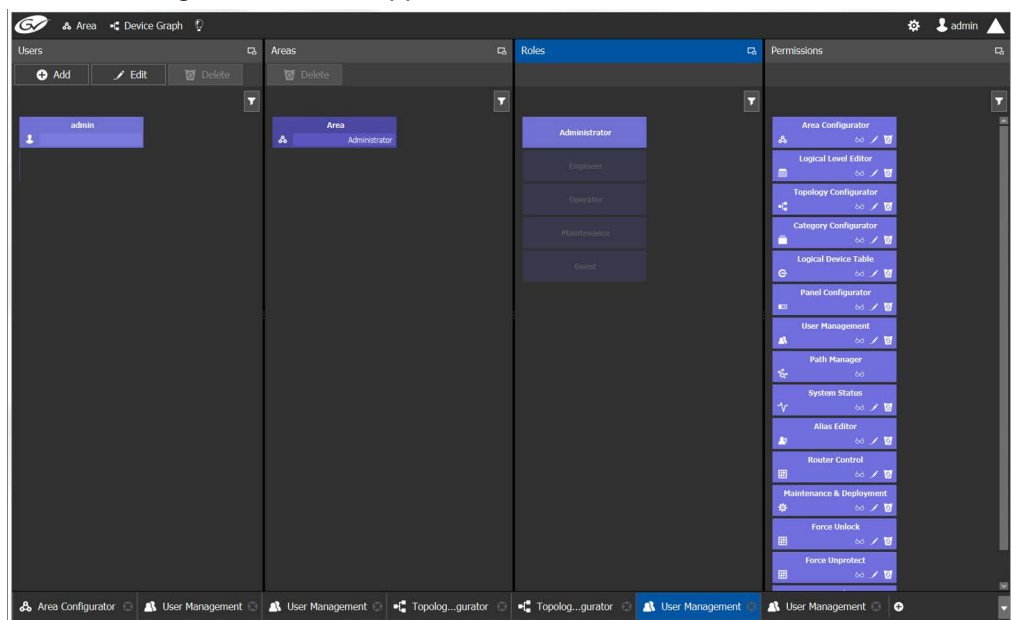

- 4 Click the **Add** button  in the top left corner.

The user configuration window appears.

User ID	jgormack
First Name	Jane
Last Name	Cormack
Password	•••••
Confirm Password	•••••
External Id	1227
<input type="button" value="Ok"/> <input type="button" value="Cancel"/>	

- 5 Enter the required information in the **User ID**, **First Name**, **Last Name**, **Password**, and **Confirm Password** fields.
- 6 If this user is to represent an external northbound routing device for Lock, Protect, and Release with the NP0016 / NP0017 router control protocol, set the **External ID** that this

device uses in its NP0017 router protocol communications with GV Orbit Control. This value is an unsigned integer. See [Setting a User ID for Lock, Protect, and Release with NDAC NP0016 / NP0017 Northbound Interfaces](#), on page 307 for more information.

Note: User databases are not synchronized between the GV Orbit Client and GV Orbit Control. You must assign the same ID to the same user in both the GV Orbit Client and GV Orbit Control.

In all cases, you must ensure that user IDs are coherent between GV Orbit Client and GV Orbit Control.

Equivalent Parameter in GV Orbit Client	Equivalent Parameter in GV Orbit Control
User name	User ID
Control External Id	External Id

See [How to Add a User](#), on page 159 for how to set these parameters in GV Orbit Client.

7 Click **OK**.

A new tile representing the new user account appears in the **Users** section.

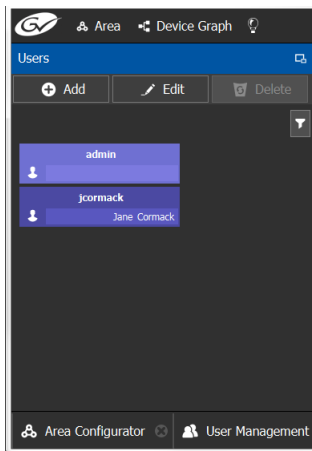

In addition, you can perform the following procedures in the **Users** section:

- **Edit:** Select the icon for the user and click **Edit** to modify the user’s credentials.
- **Delete:** Select the icon for the user and click **Delete** to remove the user account. There is no confirmation when you click **Delete**. The user profile is immediately removed.

See also

- [Switching User Profiles](#), on page 11

Granting Access Permissions to an Area

Users are granted access to each area via a predefined role. The procedure is as follows:

To grant access to an area

- 1 Launch GV Orbit Control.
- 2 Log in as an administrator.
- 3 Select **Administration > User Management**.

The User Management task appears.

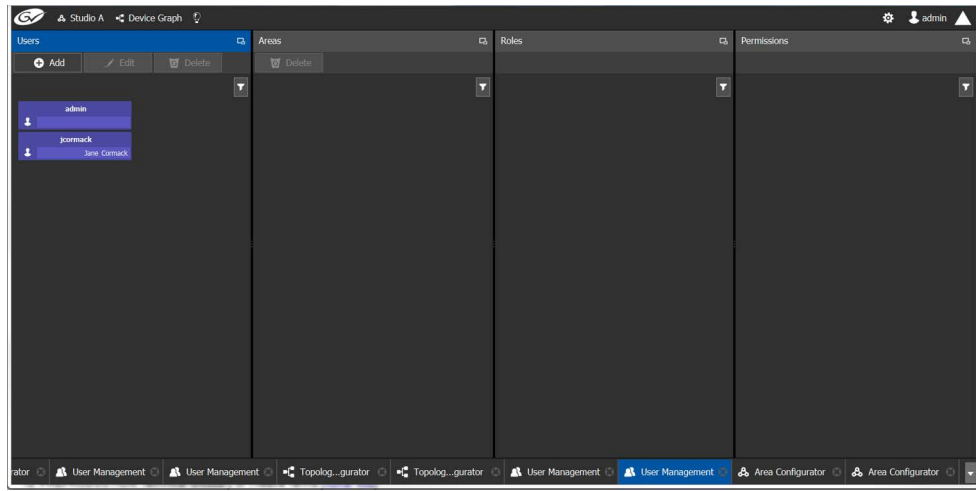

The **Users** column displays tiles for all the users who have access to the system.

- 4 Select the applicable user tile in the **Users** section.

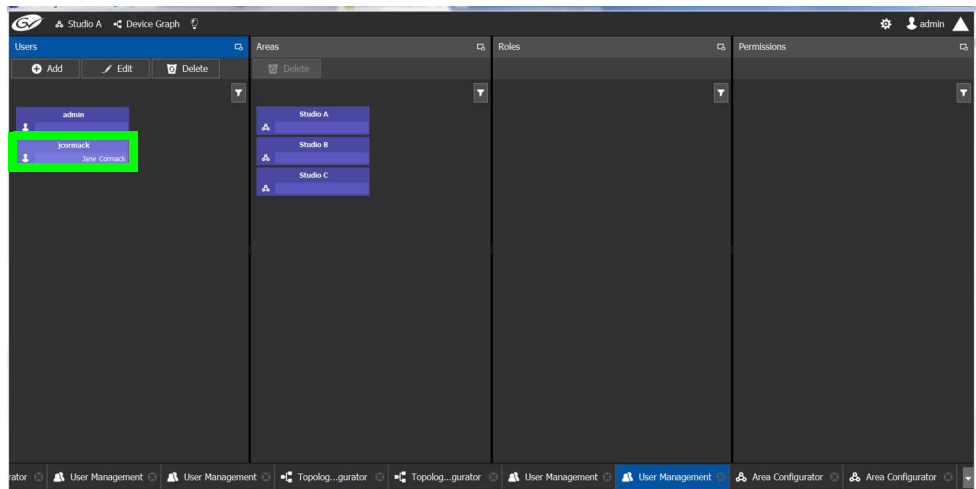

The **Areas** column displays tiles for all the areas defined in your system.

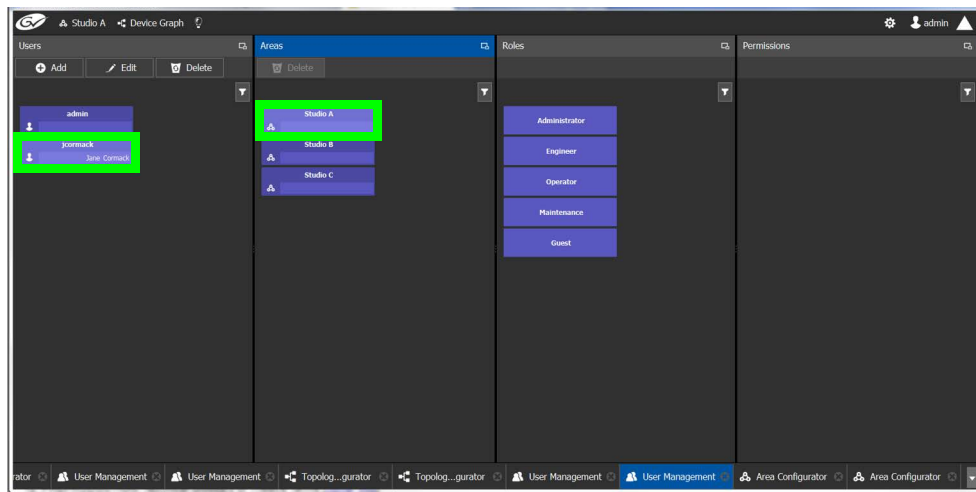

- 5 Select an area tile in the **Areas** section while keeping the user tile selected.
The **Roles** column displays tiles for all the roles when both the user tile and the area tile are selected, at the same time.
- 6 Select a role tile and drag it on top of the area tile.

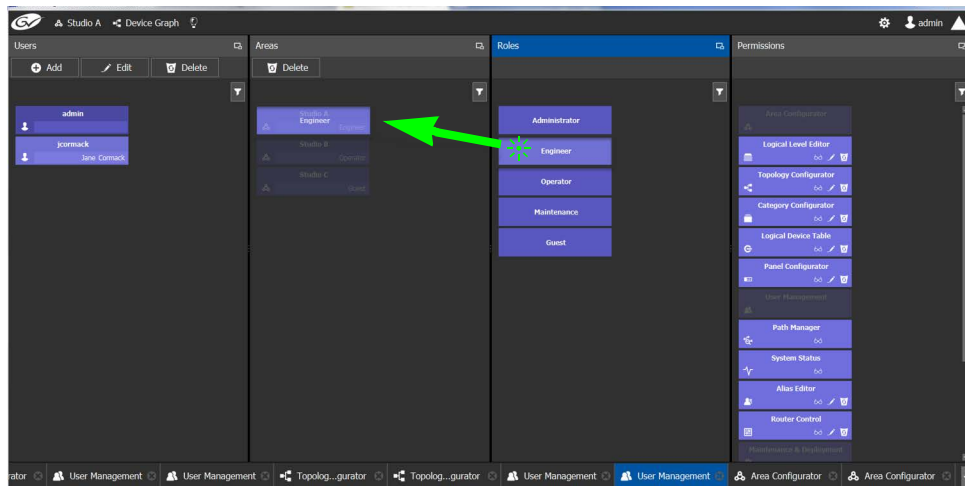

This action gives the user all the permissions defined for the role in the selected area.

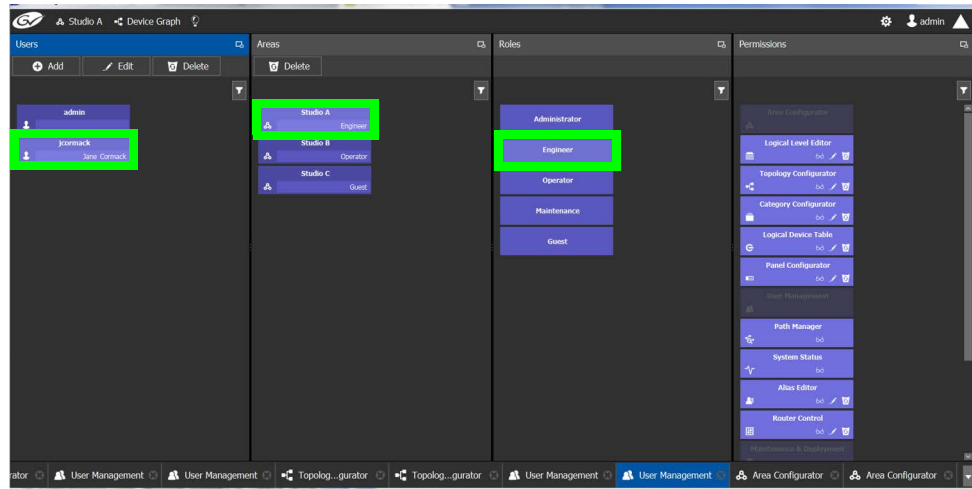

When you select the user tile in the Users section, the user's role in the area is displayed at the bottom right of the Area tile.

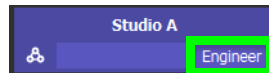

The permissions granted to the selected role; for example, view, edit, delete, are displayed on the Permissions tile in the **Permissions** column.

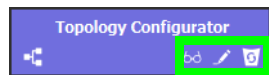

These are listed in the next section.

Viewing Permissions by Role

Users are granted access to the areas in the system via their assigned roles. The following rules apply:

- Users can be assigned to different roles in different areas.
- Users cannot be granted permissions as individuals, only according to role.
- The roles are predefined, as follows: Administrator, Engineer, Operator, Maintenance, and Guest. The roles cannot be modified.
- Administrators have full access to all tasks in all areas. Guests have the least permissions. The Engineer, Operator, and Maintenance roles have various permissions, as listed in the following table:

The permissions granted to each role can be viewed on the tiles in the Permissions list book of the User Management task. These can be viewed when the user, the area, and the role are all selected at the same time.

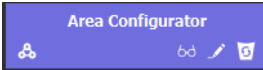
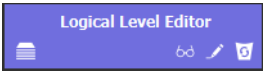
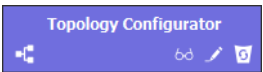
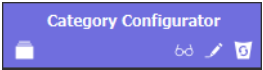
Task	Role	Permissions
Area configurator 	Administrator	View, Edit, Delete
	Engineer	No access
	Operator	No access
	Maintenance	No access
	Guest	No access
Logical Level Editor 	Administrator	View, Edit, Delete
	Engineer	View, Edit, Delete
	Operator	No access
	Maintenance	No access
	Guest	No access
Topology Configurator 	Administrator	View, Edit, Delete
	Engineer	View, Edit, Delete
	Operator	View
	Maintenance	No access
	Guest	No access
Category Configurator 	Administrator	View, Edit, Delete
	Engineer	View, Edit, Delete
	Operator	No access
	Maintenance	No access
	Guest	No access

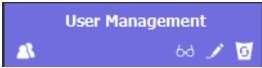
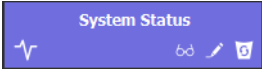
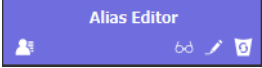
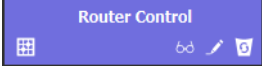
Task	Role	Permissions
Logical Device Table 	Administrator	View, Edit, Delete
	Engineer	View, Edit, Delete
	Operator	No access
	Maintenance	No access
	Guest	No access
Panel Configurator 	Administrator	View, Edit, Delete
	Engineer	View, Edit, Delete
	Operator	No access
	Maintenance	No access
	Guest	No access
User Management 	Administrator	View, Edit, Delete
	Engineer	No access
	Operator	No access
	Maintenance	No access
	Guest	No access
Path Manager 	Administrator	View
	Engineer	View
	Operator	View
	Maintenance	No access
	Guest	No access
System Status 	Administrator	View, Edit, Delete
	Engineer	View
	Operator	View
	Maintenance	View
	Guest	No access
Alias Editor 	Administrator	View, Edit, Delete
	Engineer	View, Edit, Delete
	Operator	View, Edit, Delete
	Maintenance	No access
	Guest	No access
Router Control 	Administrator	View, Edit, Delete
	Engineer	View, Edit, Delete
	Operator	View
	Maintenance	No access
	Guest	No access

Task	Role	Permissions
Maintenance & Deployment 	Administrator	View, Edit, Delete
	Engineer	No access
	Operator	No access
	Maintenance	View
	Guest	No access
Router Force Unlock  See also About Lock, Protect, and Release , on page 291 and Setting a User ID for Lock, Protect, and Release with NDAC NP0016 / NP0017 Northbound Interfaces , on page 307.	Administrator	View, Edit, Delete
	Engineer	No access
	Operator	View, Edit, Delete
	Maintenance	No access
	Guest	No access
Router Force Unprotect  See also About Lock, Protect, and Release , on page 291 and Setting a User ID for Lock, Protect, and Release with NDAC NP0016 / NP0017 Northbound Interfaces , on page 307.	Administrator	View, Edit, Delete
	Engineer	No access
	Operator	View, Edit, Delete
	Maintenance	No access
	Guest	No access
External ID 	Administrator	View, Edit, Delete
	Engineer	View, Edit, Delete
	Operator	No access
	Maintenance	No access
	Guest	No access

Setting a User ID for Lock, Protect, and Release with NDAC NP0016 / NP0017 Northbound Interfaces

With the NP0016 and NP0017 router control protocols, Lock/Protect commands require a User ID. So that users with different User IDs cannot release a destination locked by another user or panel user; in GV Orbit Control, each user can be assigned a different **External ID** parameter value. Users with a different **External ID** cannot release a destination locked by another user with a different **External ID**, unless they have *admin* or *Operator* rights.

The NP0016 and NP0017 router control protocol User ID should be set in:

- GV Orbit Control: as of GV Orbit version 2.9.0 and above, the User ID provided in northbound commands is taken into account as follows:
 - You map this User ID to the **External Id** parameter of a GV Orbit Control user set in **User Management**.
 - If this GV Orbit Control user has its **External Id** parameter value configured to the same value as the User ID in a command, the operation will be performed internally using the alias of the matching user with the user's associated privileges with respect to Lock, Protect, and Release.
 - If this GV Orbit Control user does not have *admin* or *Operator* rights, the third-party control system that uses NP0016 / NP0017 to control GV Orbit Control cannot override the lock or Protect set by other GV Orbit Control users. See [Viewing Permissions by Role](#), on page 304..
 - If no GV Orbit Control user has an **External Id** parameter value matching the command's user ID, the operation is performed internally as the GV Orbit Control *admin* user.

The User ID / **External ID** parameter is an unsigned integer.

To create a User to represent external northbound routing device in GV Orbit Control

Proceed as follows.

- 1 In GV Orbit Control, create a new user to represent the third-party control system. See [Creating User Profiles](#), on page 299.
- 2 In GV Orbit Control, set the **External Id** parameter to that of the user ID used by the third-party control system in its NP0016 / NP0017 router control protocol.

User ID	Orbit Client
First Name	Orbit
Last Name	Client
Password	*****
Confirm Password	*****
External Id	1227
<input type="button" value="Ok"/> <input type="button" value="Cancel"/>	

- 3 In GV Orbit Control, assign the privileges to this new user. See [Granting Access Permissions to an Area](#), on page 301:
 - Assign *Engineer* or *Maintenance* rights to this new user to prevent the third-party control system from overriding the lock or Protect set by other GV Orbit Control users.
 - Assign *admin* or *Operator* rights to this new user to allow the third-party control system to override the lock or Protect set by other GV Orbit Control users.

If the third-party control system's NP0016 / NP0017 router control protocol, Lock/Protect commands use a user ID that GV Orbit Control cannot match to the **External Id** value of any GV Orbit Control user, the Lock/Protect commands will be carried out as an Admin user (which has the **Router Force Unlock** and **Router Force Unprotect** privileges), thereby allowing the external control system to override the locks of other GV Orbit Control users.

See also [About Lock, Protect, and Release](#), on page 291 to better understand how Lock, Protect, and Release works with other users and other GV Orbit Control components such as panels.

GV Orbit Control stores the locks in its database and they are preserved after a restart/reboot. As such, destinations will remain locked/protected. GV Orbit Control system does not read a lock from a router and does not control a lock in the router.

Network Device Advance Control (NDAC) NP0017

The following Network Device Advance Control (NDAC) NP0017 commands are supported.

General commands

CommandId	Name	Handling
0x0000 300A	Execute System Salvo	Triggers a salvo created in GV Orbit Control by referring to it by the "external ID" of the salvo.
0x0000 310E	Register For Data Changes	Registers the client for changes to the labels within GV Orbit Control and notifies it with a '0x0000 310C Notify Mnemonic Change' when some labels are changed in GV Orbit Control.

Device-based support

Note: We recommend to northbound control systems to use Device-base commands as gaps are properly supported.

The following set of NP0017 device-based commands for support of crosspoints and labels have been implemented in the NDAC.

CommandId	Name	Handling
0x0000 3000	Take Source To Destination	Performs a crosspoint change
0x0000 3002	Lock, Protect and Release Device	Available in GV-Convergent version 2.1.4 or higher. User Id of command taken into account, when performing operation. Apply LPR state on a specific input device and level, see "lock protect release level on device" command (0x00003002). See also Setting a User ID for Lock, Protect, and Release with NDAC NP0016 / NP0017 Northbound Interfaces , on page 307.
0x0000 3004	Register for Changes to Device	Registers the client for changes to the port and notifies it with a '0x0000 300B Device Status Changed' when the crosspoint changes in GV Orbit Control.
0x0000 3006	Get Destination Status	Returns the current crosspoint status.
0x0000 3008	Get Device LPR Status	Available in GV-Convergent version 2.1.4 or higher. Returns the output's current lock/protect/release status. If a user has an "external ID" value configured it is returned, otherwise 0 is returned.

CommandId	Name	Handling
0x0000 3012	Get Mnemonics	Allows client to retrieve the mnemonics for 'all devices', 'levels', 'sources', 'destinations' and 'categories'. Limited to 8 first characters of the "Short name" property. Categories are not supported.
0x0000 3016	Device All Levels Take	Performs a take between a source and destination on all the available levels.
0x0000 3017	Get Simple Device Status	Provides the input connected to a destination device. For GV Orbit Control version 2.0.0 or higher, returns all levels including sub-levels of composite levels. For GV Orbit Control versions before 2.0.0, the command returns only levels assigned to the logical source or destination.
0x0000 3018	Get Device Levels	Returns the levels associated to a device. For GV Orbit Control version 2.0.0 or higher: <ul style="list-style-type: none"> • Returns all levels including sub-levels of composite levels. • Returns the levels with the right device id. For GV Orbit Control versions before 2.0.0: <ul style="list-style-type: none"> • Returns only levels assigned to the logical source or destination. • Returns the levels of the device id - 1.
0x0000 3022	Get Extended Mnemonics	Returns associated device mnemonics. Only types 1,2,3 and 4 are handled. No limit on name length. This returns no category information.
0x0000 302B	Get Contents For Category	This returns no category information.
0x8000 300B	Device Output Changed Response	This is a response message sent back by clients after GV Orbit Control sends out a 0x0000 300B. For GV Orbit Control version 2.0.0 or higher, it simply ignores these messages. For GV Orbit Control versions before 2.0.0, the command unknown status is returned.

Details about device id and level numbers

- The *Device ID* fields used in the device-based commands are 1-based values. Meaning that *Source Device ID* 1 in a command matches the logical source with external id 1 in GV Orbit Control.
- The *Virtual Level ID* field used in the device-based commands are 1-based values. Meaning that *Virtual Level ID* 1 in a command matches the logical level with ID 1 (SDI) in GV Orbit Control.

Port-based support

GV Orbit Control supports the following set of NP0017 port-based commands in the NDAC.

CommandId	Name	Handling
0x0000 3001	Take Input To Output	Performs a crosspoint change
0x0000 3003	Lock, Protect and Release Port	Available in GV-Convergent version 2.1.4 or higher. User Id of command taken into account, when performing operation. Apply LPR state on a specific input port and level, supports NP0017 "lock protect release port" command (0x00003003). See also Setting a User ID for Lock, Protect, and Release with NDAC NP0016 / NP0017 Northbound Interfaces , on page 307.
0x0000 3005	Register for Changes to Port	Registers the client for changes to the port and notifies it with a '0x0000 300C Physical Port Changed' when the crosspoint changes in GV Orbit Control.
0x0000 3007	Get Physical Crosspoint Status	Returns the current crosspoint status.
0x0000 3009	Get Physical LPR Status	Available in GV-Convergent version 2.1.4 or higher. Returns the output's current lock/protect/release status. If a user has an "external ID" value configured it is returned, otherwise 0 is returned.
0x0000 3014	Get Physical Level Dimensions	Returns the logical level ids and size for the area being controlled.
0x0000 3015	Get Mnemonic For Ports	Returns the first 8 characters of 'Short name' property for the requested input or output port.
0x0000 3025	Get Extended Mnemonics For Ports	Returns the full 'Short name' property for the requested input or output port. Not limited in length.
0x8000 300C	Physical crosspoint status response.	This is a response message sent back by clients after GV Orbit Control sends out a 0x0000 300C. For GV Orbit Control version 2.0.0 or higher, it simply ignores these messages. For GV Orbit Control versions before 2.0.0, the command unknown status is returned.

Details about port and level numbers

- The *Input Port* and *Output Port* fields used in the port-based commands are 0-based values. Meaning that *Input Port* 0 in a command matches the logical source with external id 1 in GV Orbit Control.
- The port numbers (external Id values) should be sequential in GV Orbit Control. That is, port-based commands do not work properly if there are gaps in the external IDs.
- The *Physical Level ID* field used in the port-based commands are 1-based values. Meaning that *Physical Level ID* 1 in a command matches the logical level with ID 1 (SDI) in GV Orbit Control.

User ID and Lock, Protect, and Release

User ID is a concept found in some protocols such as NP0016 and NP0017. It allows a northbound controller to identify the user which is performing lock/protect or take operations. In turn GV Orbit Control, will try to match the provided user ID to one of its users by looking up the **External Id** parameter value and perform the operations internally using it.

See also [Setting a User ID for Lock, Protect, and Release with NDAC NP0016 / NP0017 Northbound Interfaces](#), on page 307.

NOTE: GVG NP and Probel SW-P-08 protocols do not have user ID concepts, so all their operations are performed as the GV Orbit Control *admin* user.

GV Orbit Control user external id configuration

NP0016 and NP0017 protocols provide the user ID for various operations. The user ID is defined as an unsigned integer value from 0 to 4294967295 but it's recommended to NOT use values beyond 2147483647 to avoid any conversion or any special handling of users ID in GV Orbit Control systems. If the recommendation cannot be applied, please contact Grass Valley support for further details on how to configure those values in GV Orbit Control systems. See [Grass Valley Technical Support](#), on page 845.

User IDs used by Northbound Control Systems

NDAC Client	User ID
iControl - NP0017 device based	0 An iControl system property can be configured to change this.
iControl - NP0017 port based	0
iControl - NP0016	61441 (0xF001)
Image Video - NP0017 device based	0

How to...

How to configure iControl or Kaleido to control GV Orbit Control using NP0017 device-id-based driver

- 1 Add and configure a physical router:
 - a Add the physical router in router manager or Xedit.
 - b Select the 'NVEP NV9000 - Device Takes (NP0017)' router protocol.
 - c Set the Connection type to: TCP/IP
 - d Enter the GV Orbit Control controller IP address.
 - e Set the TCP/IP port to 9193 + 'external id'. For example: if the area 'external id' in GV Orbit Control is '0' use port 9193, if area 'external id' in GV Orbit Control is '1' use port 9194.
 - f Add a physical level.

- g Configure its size and enter any number in the 'Level or frame ID' field. Kaleido and iControl only do all 'level takes'.
The matrix size should be at least the 'amount of sources of the topology with the most sources' X 'amount of destinations of the topology with the most destinations' as shown in the GV Orbit Control Alias Editor of the area. If you intend to remove/add sources or destinations in GV Orbit Control you should make the router size bigger as 'NP0017 ID' aren't reused.
- 2 Create a logical router:
 - a Set the size and add the logical level.
The logical level can be a subset of all the physical inputs or outputs in GV Orbit Control. That way you can control only certain sources or destinations.
 - b Select the physical levels configured.
 - c Perform the auto-map of sources and destinations.
 - d Save.
 - 3 Control GV Orbit Control using router matrix.

How to configure iTX to control GV Orbit Control using NP0017 device-id-based driver

- Create a router in iTX and select the 'NV9000' driver.

How to configure NV9000 to control GV Orbit Control using NP0017 device-id-based driver

- NV9000 doesn't support this mode of communication with a router controller.

How to configure iControl or Kaleido to control GV Orbit Control using NP0017 port-based driver

- 1 Add and configure a physical router:
 - a Add the physical router in router manager or Xedit.
 - b Select the 'NVEP NV9000 - Port Takes (NP0017)' router protocol.
 - c Set the Connection type to: TCP/IP
 - d Enter the GV Orbit Control controller IP address.
 - e Set the TCP/IP port to 9193 + 'external id'. For example: if the area 'external id' in GV Orbit Control is '0' use port 9193, if area 'external id' in GV Orbit Control is '1' use port 9194.
 - f Add a physical level.
 - g Configure its size and enter '1' in the 'Level or frame ID' field.
The matrix size should be the total amount of source and destination 'External IDs' within the GV Orbit Control Alias Editor of the area.
 - h Add other levels as needed.
- 2 Create a logical router:
 - a Set the size and add the logical level.
The logical level can be a subset of all the physical inputs or outputs in GV Orbit Control. That way you can control only certain sources or destinations.

- b Select the physical levels configured.
 - c Perform the auto-map of sources and destinations.
 - d Save.
- 3 Control GV Orbit Control using router matrix.

How to configure NV9000 to control GV Orbit Control using NP0017 port based driver

- 1 Configure the 'area id' in GV Orbit Control to '0'.
- 2 Access the SE-Utilities application.
- 3 Add a router:
 - a Go to Configuration > Routers and click the 'Add router' button.
 - b Enter a name for the router.
 - c Select 'NV Control System Ethernet' as the protocol
 - d Click next.
 - e Add a Physical Level and configure the level '#' value to match the GV Orbit Control logical level 'external Id' from within Area.
 - f Enter '0' for the 'Input Start' and 'Output Start'.
 - g Enter the number of GV Orbit Control inputs - 1 in 'Input End'
 - h Enter the number of GV Orbit Control outputs - 1 in the 'Output End'
- 4 Add a level set:
 - a Go to Configuration > Level Sets and click the 'add level set' button.
 - b Enter a name for the level set.
 - c Select a 'Virtual Level' value for 'display index' 1.
 - d Select a Physical level from the pull down.
- 5 Add devices:
 - a Go to Configuration > Devices and click 'Add Device' button.
 - b Enter a mnemonic, select a level set and optionally enter a description.
 - c Click the 'Next' button.
 - d In the 'Device Level Detail' section enter the input or output numbers used by the Device.
 - e Repeat to add more devices.
- 6 Apply the DB to the controller:
 - a Go to System Management and select the NV9000 controller.
 - b Click the 'Write configuration to NV9000' button.
 - c Once the copying is done, click the 'Restart controller 1' button.
- 7 Control GV Orbit Control using SE-Utilities:
 - a Go to System Management > NV9000 controller > Routers and select the router representing GV Orbit Control.

There is a bug in SE-Utilities when output 0 is used. It's status isn't displayed in the 'Connections' table. If you wish to view the status of output 0, you can change the 'Starting Output' value to 0 instead of 1, but you will loose the status of the last output. The 'Display Count' value cannot be higher than the last output number of

the physical level, which is one less than the output count when using 0-based values.

- b You can perform takes by using 0-based input and output values.

Northbound Control through Sony LSM (NS-BUS Router Matrix protocol)

GV Orbit Control system's northbound interface has the ability to control crosspoints through Sony LSM (NS-BUS router matrix protocol).

With this integration, logical sources/destinations from GV Orbit Control systems, including those created for NMOS devices, are now available northbound to be used by Sony panels and commands received through *NS-BUS router matrix protocol* are handled.

LSM does not allow the configuration of the TCP port to which it connects to on an NS-BUS router device and uses 9720 by default. Because of this limitation, only one area of GV Orbit Control systems can be controlled. GV Orbit Control systems allow control of the area with the lowest external ID through the NS-BUS protocol.

When adding a GV Orbit Control system as an NS-BUS Device in the LSM configuration, the selected Protocol must be TCP and the Device Port Number value must be 8079. Device IP Address1 field should be the Virtual IP address of the GV Orbit Control system. Device IP Address2 field must be empty.

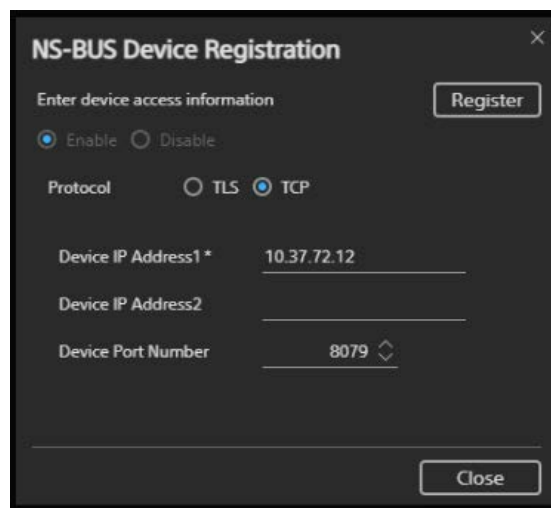

The screenshot shows a dialog box titled "NS-BUS Device Registration" with a close button (X) in the top right corner. Below the title is the text "Enter device access information" and a "Register" button. There are two radio buttons for "Enable" (selected) and "Disable". Below that is a "Protocol" section with two radio buttons: "TLS" and "TCP" (selected). There are three input fields: "Device IP Address1 *" with the value "10.37.72.12", "Device IP Address2" which is empty, and "Device Port Number" with a dropdown menu showing "8079". A "Close" button is located at the bottom right of the dialog.

See [Configuring a Controller Group](#), on page 19 for the Virtual IP address of the GV Orbit Control system.



Grass Valley Technical Support

For technical assistance, contact our international support center, at 1-800-547-8949 (US and Canada) or +1-530-478-4148.

To obtain a local phone number for the support center nearest you, consult the Contact Us section of Grass Valley's website (www.grassvalley.com).

An online form for e-mail contact is also available from the website.

Corporate Head Office

Grass Valley
3499 Douglas-B.-Floreani
St-Laurent, Quebec H4S 2C6
Canada
Telephone: +1 514 333 1772
Fax: +1 514 333 9828
www.grassvalley.com