

PFR700/E

FIBRE CHANNEL RAID STORAGE SYSTEM

Instruction Manual

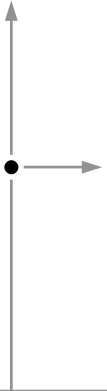

071-8306-01
MAY 2006

the most watched worldwide

Copyright

Copyright © 2006 Grass Valley, Inc. All rights reserved. Printed in the United States of America.

This document may not be copied in whole or in part, or otherwise reproduced except as specifically permitted under U.S. copyright law, without the prior written consent of Grass Valley, Inc., P.O. Box 59900, Nevada City, California 95959-7900

This product may be covered by one or more U.S. and foreign patents.

Trademarks

Grass Valley, K2, Turbo, M-Series, Profile, Profile XP, NewsBrowse, NewsEdit, NewsQ, NewsShare, NewsQ Pro, and Media Manager are either registered trademarks or trademarks of Grass Valley, Inc. in the United States and/or other countries. Other trademarks used in this document are either registered trademarks or trademarks of the manufacturers or vendors of the associated products. Grass Valley, Inc. products are covered by U.S. and foreign patents, issued and pending. Additional information regarding Grass Valley, Inc. trademarks and other proprietary rights may be found at www.thomsongrassvalley.com.

Disclaimer

Product options and specifications subject to change without notice. The information in this manual is furnished for informational use only, is subject to change without notice, and should not be construed as a commitment by Grass Valley, Inc. Grass Valley, Inc. assumes no responsibility or liability for any errors or inaccuracies that may appear in this publication.

**U.S. Government
Restricted Rights
Legend**

Use, duplication, or disclosure by the United States Government is subject to restrictions as set forth in subparagraph (c)(1)(ii) of the Rights in Technical Data and Computer Software clause at DFARS 252.277-7013 or in subparagraph c(1) and (2) of the Commercial Computer Software Restricted Rights clause at FAR 52.227-19, as applicable. Manufacturer is Grass Valley, Inc., P.O. Box 59900, Nevada City, California 95959-7900 U.S.A.

Revision Status

Rev Date	Description
February 27, 2004	Initial release of the PFR700 Instruction Manual. Part number 071-8306-00
May 9, 2006	Corrected controller DIP switch settings. Part number 071-8306-01

Contents

	Safety Summaries	5
	Preface	11
	About this manual.....	11
	Using the Profile XP Documentation Set.....	11
	Manual Descriptions.....	12
	How this manual is organized.....	12
	Getting more information.....	13
	On-line manuals.....	13
	Grass Valley Product Support.....	14
Chapter 1	About the PFR 700 Series	
	PFR700 Series features.....	15
	PFR700 features.....	16
	Capacity and redundancy.....	16
	PFR700 Series components.....	16
	Chassis.....	17
	Midplane.....	18
	Disk modules.....	18
	PFR700/E Circuit board modules.....	19
	PFR700 RAID Storage Chassis circuit board modules.....	19
	PFR700E RAID Expansion Chassis circuit board modules.....	20
	Power supplies.....	21
	Configurations.....	22
Chapter 2	PFR 700 Series Installation Information	
	Installation requirements.....	23
	Site requirements.....	23
	Power.....	23
	Cooling.....	23
	Controller configuration requirements.....	24
	Addressing requirements.....	25
	FC-AL address ID.....	25
	Chassis address setting requirement.....	27
	Expansion chassis diagnostic switch setting requirement.....	27
	Cabling requirements.....	28
	Binding disk modules into groups.....	29
	Installing a PFR 700/E in an equipment rack.....	30
	Unpacking the chassis.....	30
	Installing the rack mounts.....	30
	Inserting the PFR700/E chassis in the rack.....	33
	PFR700/E power-up and initialization.....	35
	Connecting electrical cables.....	35
	Powering-up the PFR700/E system.....	35
	PFR700/E power-down.....	36
	Battery Backup.....	36
Chapter 3	Servicing the PFR 700 Series RAID	
	Maintenance procedures using GVG Disk Utility.....	37
	Monitoring PFR700 Series RAID status using NetCentral.....	38
	Interpreting disk module LEDs.....	40
	Interpreting controller status LEDs.....	41
	Interpreting expansion adapter status LEDs.....	43
	Interpreting LAN card status LEDs.....	44
	Interpreting power supply status LEDs.....	45

	Removing and installing disk modules	45
	Moving disk modules	45
	Removing a disk module	46
	Installing disk module	47
	Replacing a RAID controller or expansion adapter	48
	Removing a RAID controller or expansion adapter	48
	Installing a RAID controller or expansion adapter	50
	Replacing the LAN card	52
	Replacing a power supply	54
Chapter 4	PFR 700 Series Technical Specifications and Operating Limits	
	AC power requirements	59
	Size and weight	59
	Cable lengths	59
	Environmental limits	60
	Life expectancies of components	60
	Glossary	61
	Index	65

Safety Summaries

General Safety Summary

Review the following safety precautions to avoid injury and prevent damage to this product or any products connected to it.

Only qualified personnel should perform service procedures.

While using this product, you may need to access other parts of the system. Read the *General Safety summary* in other system manuals for warnings and cautions related to operating the system.

Injury Precautions

Use Proper Power Cord

To avoid fire hazard, use only the power cord specified for this product.

Ground the Product

This product is grounded through the grounding conductor of the power cord. To avoid electric shock, the grounding conductor must be connected to earth ground. Before making connections to the input or output terminals of the product, ensure that the product is properly grounded.

Do Not Operate Without Covers

To avoid electric shock or fire hazard, do not operate this product with covers or panels removed.

Do Not operate in Wet/Damp Conditions

To avoid electric shock, do not operate this product in wet or damp conditions.

Do Not Operate in an Explosive Atmosphere

To avoid injury or fire hazard, do not operate this product in an explosive atmosphere.

Avoid Exposed Circuitry

To avoid injury, remove jewelry such as rings, watches, and other metallic objects. Do not touch exposed connections and components when power is present.

Product Damage Precautions

Use Proper Power Source

Do not operate this product from a power source that applies more than the voltage specified.

Provide Proper Ventilation

To prevent product overheating, provide proper ventilation.

Do Not Operate With Suspected Failures

If you suspect there is damage to this product, have it inspected by qualified service personnel.

Battery Replacement

To avoid damage, replace only with the same or equivalent type recommended by the circuit board manufacturer. Dispose of used battery according to the circuit board manufacturer's instructions.

Safety Terms and Symbols

Terms in This Manual

These terms may appear in this manual:



WARNING: Warning statements identify conditions or practices that can result in personal injury or loss of life.



CAUTION: Caution statements identify conditions or practices that may result in damage to equipment or other property, or which may cause equipment crucial to your business environment to become temporarily non-operational.

Terms on the Product

These terms may appear on the product:

DANGER indicates a personal injury hazard immediately accessible as one reads the marking.

WARNING indicates a personal injury hazard not immediately accessible as you read the marking.

CAUTION indicates a hazard to property including the product.

Symbols on the Product

The following symbols may appear on the product:



DANGER high voltage



Protective ground (earth) terminal



ATTENTION – refer to manual

Service Safety Summary



WARNING: *The service instructions in this manual are intended for use by qualified service personnel only. To avoid personal injury, do not perform any servicing unless you are qualified to do so. Refer to all safety summaries before performing service.*

Do Not Service Alone

Do not perform internal service or adjustment of this product unless another person capable of rendering first aid and resuscitation is present.

Disconnect Power

To avoid electric shock, disconnect the main power by means of the power cord or, if provided, the power switch.

Use Care When Servicing With Power On

Dangerous voltages or currents may exist in this product. Disconnect power and remove battery (if applicable) before removing protective panels, soldering, or replacing components.

To avoid electric shock, do not touch exposed connections.

Certifications and Compliances

Canadian Certified Power Cords

Canadian approval includes the products and power cords appropriate for use in the North America power network. All other power cords supplied are approved for the country of use.

FCC Emission Control

This equipment has been tested and found to comply with the limits for a Class A digital device, pursuant to Part 15 of the FCC Rules. These limits are designed to provide reasonable protection against harmful interference when the equipment is operated in a commercial environment. This equipment generates, uses, and can radiate radio frequency energy and, if not installed and used in accordance with the instruction manual, may cause harmful interference to radio communications. Operation of this equipment in a residential area is likely to cause harmful interference in which case the user will be required to correct the interference at his own expense. Changes or modifications not expressly approved by Grass Valley can affect emission compliance and could void the user's authority to operate this equipment.

Canadian EMC Notice of Compliance

This digital apparatus does not exceed the Class A limits for radio noise emissions from digital apparatus set out in the Radio Interference Regulations of the Canadian Department of Communications.

Le présent appareil numérique n'émet pas de bruits radioélectriques dépassant les limites applicables aux appareils numériques de la classe A prescrites dans le Règlement sur le brouillage radioélectrique édicté par le ministère des Communications du Canada.

EN55103 1/2 Class A Warning

This product has been evaluated for Electromagnetic Compatibility under the EN 55103-1/2 standards for Emissions and Immunity and meets the requirements for E4 environment.

This product complies with Class A (E4 environment). In a domestic environment this product may cause radio interference in which case the user may be required to take adequate measures.

FCC Emission Limits

This device complies with Part 15 of the FCC Rules. Operation is subject to the following two conditions: (1) This device may not cause harmful interference, and (2) this device must accept any interference received, including interference that may cause undesirable operation.

Laser Compliance

Laser Safety Requirements

The device used in this product is a Class 1 certified laser product. Operating this product outside specifications or altering its original design may result in hazardous radiation exposure, and may be considered an act of modifying or new manufacturing of a laser product under U.S. regulations contained in 21CFR Chapter 1, subchapter J or CENELEC regulations in HD 482 S1. People performing such an act are required by law to recertify and reidentify this product in accordance with provisions of 21CFR subchapter J for distribution within the U.S.A., and in accordance with CENELEC HD 482 S1 for distribution within countries using the IEC 825 standard.

Laser Safety

Laser safety in the United States is regulated by the Center for Devices and Radiological Health (CDRH). The laser safety regulations are published in the "Laser Product Performance Standard," Code of Federal Regulation (CFR), Title 21, Subchapter J.

The International Electrotechnical Commission (IEC) Standard 825, "Radiation of Laser Products, Equipment Classification, Requirements and User's Guide," governs laser products outside the United States. Europe and member nations of the European Free Trade Association fall under the jurisdiction of the Comité Européen de Normalization Electrotechnique (CENELEC).

Safety Certification

This product has been evaluated and meets the following Safety Certification Standards:

Standard	Designed/tested for compliance with:
UL1950	Safety of Information Technology Equipment, including Electrical Business Equipment (Third edition).
IEC 950	Safety of Information Technology Equipment, including Electrical Business Equipment (Second edition, 1991).
CAN/CSA C22.2, No. 950-95	Safety of Information Technology Equipment, including Electrical Business Equipment.
EN60950	Safety of Information Technology Equipment, including Electrical Business Equipment 1992.

Preface

About this manual

The PFR700/E Fibre Channel RAID Storage Chassis provides RAID protected storage for Profile XP Media Platforms and Grass Valley Open SANs. If you are responsible for installing and servicing the PFR700/E in one of these systems, you should read this manual.

Using the Profile XP Documentation Set

This manual is part of a full set of support documentation for the Profile XP Media Platform. The following figure illustrates how to use the Profile XP documentation depending on the task you are performing. For instructions on connecting and configuring the PFR700 Series Fibre Channel RAID Storage Chassis, consult the Profile XP Installation Guide (local storage) or Open SAN Instruction Manual (shared storage) depending on the system you are installing.

Path for the Installer

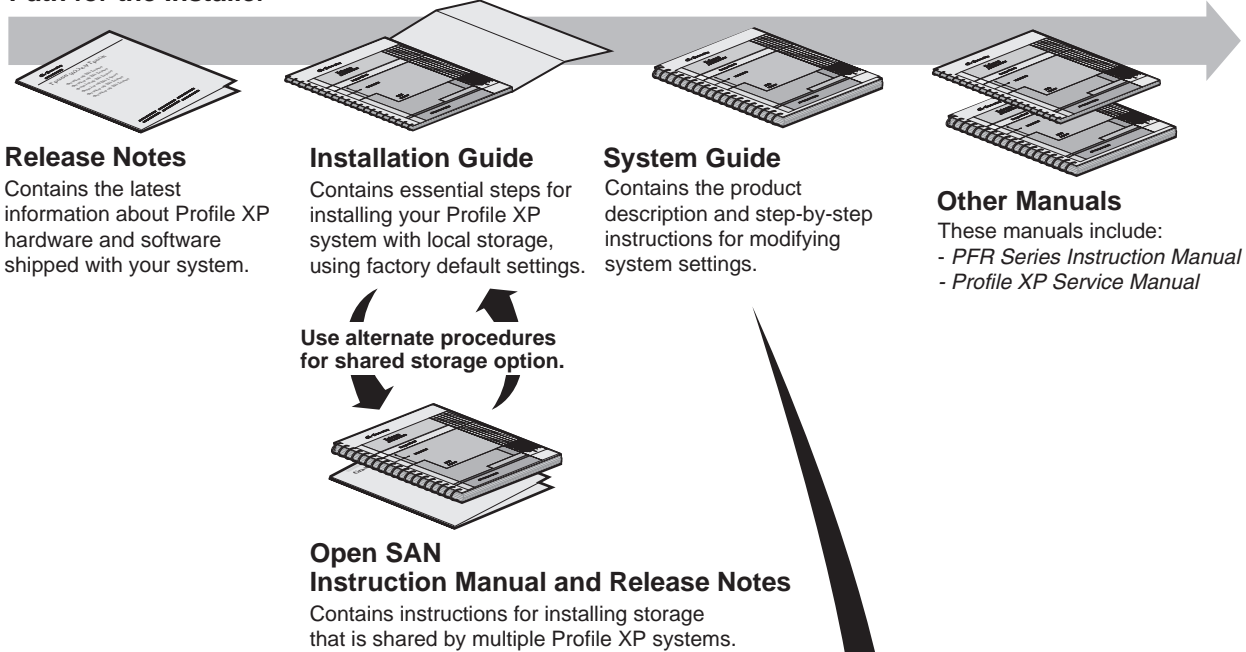

Path for the Operator

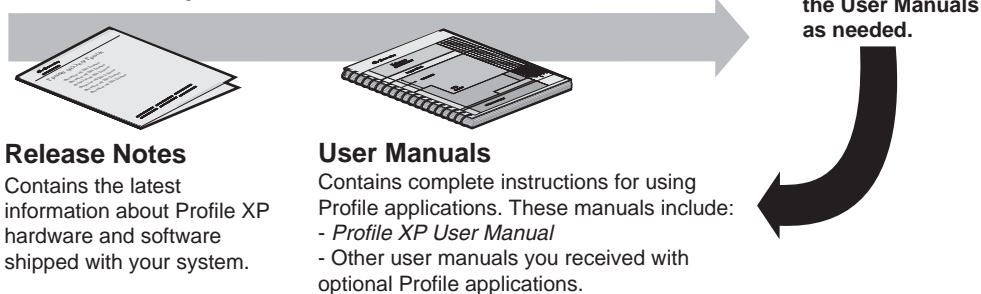

Manual Descriptions

- **Installation Guide** (for each Profile XP Model) This guide provides step-by-step instructions for installing the Profile XP Media Platform using factory default settings for all record/play channels. Factory default settings are indicated within the guide. After installing the Profile XP system using the installation guide, you can refer to the *Profile XP System Guide* to customize system settings for your installation.
- **Profile XP System Guide** This guide provides all the information you need to go beyond factory default settings and customize your system's configuration to meet your site-specific needs. This guide also provides an overview of your Profile XP system, and provides all the specifications you need to integrate the Profile XP Media Platform into your operation.
- **Profile XP User Manual** Contains complete instructions for using Profile applications to operate the Profile XP Media Platform.
- **Profile XP Service Manual** Contains information for servicing the Profile XP Media Platform, and includes procedures for the following tasks:
 - Problem analysis using symptom, problem, solution tables.
 - Running diagnostics locally and remotely
 - Set up and operation of NetCentral monitoring software.
 - Replacing field replaceable units.
- **Profile XP Release Notes** Contains the latest information about the Profile hardware and the software release shipped on your system. This information includes software specifications and requirements, feature changes from the previous releases, helpful system administrative information, and any known problems.
- **PFR700 Instruction Manual** Contains information for servicing the PFR700 Series Fibre Channel RAID Storage Chassis including step-by-step procedures for replacing field replaceable units.

How this manual is organized

The *PFR Series Instruction Manual* is organized around the tasks you'll be performing to install and service your Fibre Channel RAID Storage System. You can see this reflected in the chapter titles chosen for this manual. The following identifies and describes the chapters included in this manual:

Chapter 1, About the PFR700 Series

Introduces the PFR700 Series Fibre Channel RAID Storage Chassis (PFR700) and the RAID Expansion Chassis (PFR700E). You can read this chapter to get familiar with the RAID Storage Chassis key features and components.

Chapter 2, PFR700 Series Installation Information

Describes how to install a RAID Storage Chassis and RAID Expansion Chassis, including rack mounting. Refer to the *Profile XP System Guide* for connection and configuration information.

Chapter 3, Servicing the PFR700 Series RAID

Describes how to replace FRUs, such as disk modules, and add disk modules and redundant FRUs.

[Chapter 4, PFR700 Series Technical Specifications and Operating Limits](#)

This appendix consists of electrical and environmental specifications.

[Glossary](#)

The Glossary explains terms used throughout this manual.

Getting more information

In addition to printed documents, Profile XP product information is available in on-line manuals. Use these as additional sources for information.

On-line manuals

Electronic versions of the following manuals are located on the system drive of your Profile XP Media Platform and on the Profile XP software CD-ROM.

- *Installation Guide (for your model)*
- *Profile XP System Guide*
- *Profile XP User Manual*
- *Profile XP Service Manual*
- *PFR Series Instruction Manual*
- *Profile XP Release Notes*

You can view these manuals using Adobe Acrobat Reader which is also pre-installed on your Profile XP system.

Grass Valley Product Support

To get technical assistance, check on the status of problems, or report new problems, contact Grass Valley Product Support via e-mail, the Web, phone, or fax.

Web Technical Support

To access support information on the Web, visit the product support Web page on the Grass Valley Web site. You can download software or find solutions to problems by searching our Frequently Asked Questions (FAQ) database.

World Wide Web: <http://www.thomsongrassvalley.com/support/>

Technical Support E-mail Address: gvgtechsupport@thomson.net.

Phone Support

Use the following information to contact product support by phone during business hours. Afterhours phone support is available for warranty and contract customers.

United States	(800) 547-8949 (Toll Free)	France	+33 (1) 34 20 77 77
Latin America	(800) 547-8949 (Toll Free)	Germany	+49 6155 870 606
Eastern Europe	+49 6155 870 606	Greece	+33 (1) 34 20 77 77
Southern Europe	+33 (1) 34 20 77 77	Hong Kong	+852 2531 3058
Middle East	+33 (1) 34 20 77 77	Italy	+39 06 8720351
Australia	+61 3 9721 3737	Netherlands	+31 35 6238421
Belgium	+32 2 3349031	Poland	+49 6155 870 606
Brazil	+55 11 5509 3440	Russia	+49 6155 870 606
Canada	(800) 547-8949 (Toll Free)	Singapore	+656379 1390
China	+86 106615 9450	Spain	+ 34 91 512 03 50
Denmark	+45 45968800	Sweden	+46 87680705
Dubai	+ 971 4 299 64 40	Switzerland	+41 (1) 487 80 02
Finland	+35 9 68284600	UK	+44 870 903 2022

Authorized Support Representative

A local authorized support representative may be available in your country. To locate the support representative for your country, visit the product support Web page on the Grass Valley Web site.

Profile Users Group

You can connect with other Profile XP Media Platform users to ask questions or share advice, tips, and hints. Send e-mail to profile-users@thomson.net to join the community and benefit from the experience of others.

About the PFR700 Series

This chapter introduces the PFR700 Series Fibre Channel RAID Storage Chassis. Topics include:

- “PFR700 Series features” on page 15
- “PFR700 Series components” on page 16
- “Configurations” on page 22

PFR700 Series features

The PFR700 Series Fibre Channel RAID Storage Chassis is a high performance, high availability mass storage system. High-bandwidth storage is made possible using Fibre Channel Arbitrated Loop (FC-AL) technology. The PFR700 Series’s modular, scalable design provides additional disk storage as your needs increase.

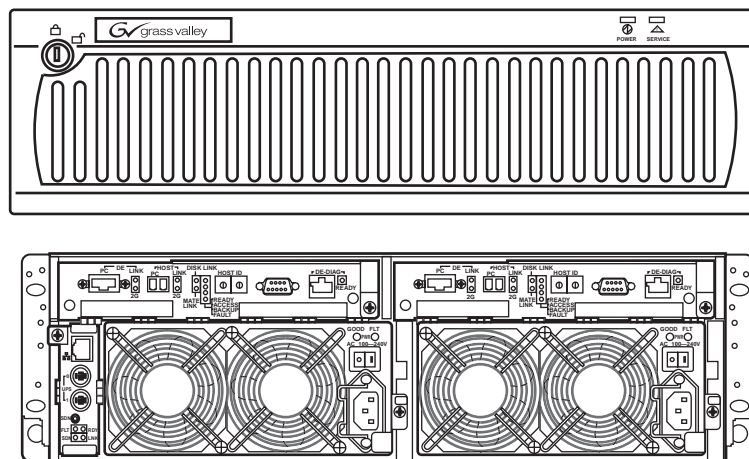

Feature highlights:

- 15 drives in a 3U vertical rack space
- No single point of failure
- All active components are hot-serviceable
- Scalable expansion using RAID Expansion Chassis
- Optional dual RAID controllers provide Fibre Channel failover
- Optical Fibre Channel Small Form-Factor interface

The PFR700 utilizes dual FC-AL technology, allowing two loop configurations within a single chassis. Loop integrity is maintained during failures without user intervention. Each loop and associated circuits along with all other active components are on redundant, separate hot swappable modules. This improves serviceability and increases fault tolerance by eliminating any single point of failure.

PFR 700 features

The PFR 700 controllers provide enhanced performance of up to 2 Gb/s transfer rates using SCSI protocol. Optical cables connect to hosts, such as to a Profile XP Media Platform equipped with a Fibre Channel Disk II card, or to a Fibre Channel switch in an Open SAN installation.

The PFR 700 supports one PFR700E RAID Expansion Chassis. It does not support connection to PFC500E, PFR500E, or PFR600E RAID Expansion Chassis. Copper cables connect a PFR 700 to the PFR700E RAID Expansion Chassis.

Capacity and redundancy

The PFR 700 Series contains five, ten, or fifteen half-height 3.5" Fibre Channel Arbitrated Loop (FC-AL) disk drives. The chassis also supports one or two hardware RAID controllers in one 3U high rack-mountable chassis. The PFR 700 Series currently uses 36GB, 73GB or 146GB drive capacities. With 15 drives, one chassis holds up to 540GB, 1.095TB, or 2.19TB depending on the disk drive option.

The PFR 700E RAID Expansion Chassis provides additional storage capacity. One PFR 700E RAID Expansion Chassis can be connected to a single PFR 700 comprising a single disk-array storage system with a total of 30 drives and 1.08TB, 2.19TB, or 4.38TB of storage depending on the disk drive option. This provides for cost effective storage expansion as requirements grow.

PFR 700 Series components

The PFR 700 Series components are:

- The chassis with passive midplane board
- One or two RAID controllers (PFR700) or two expansion adapters (PFR700E)
- As many as fifteen Fibre Channel disk drives per chassis
- Two RAID chassis power supplies (PFR 700) or expansion chassis power supplies (PFR700E)
- One LAN card (PFR 700 only)

Any unoccupied slot (RAID controller, disk module, or LAN card) has a filler module to maintain air flow and compliance with electromagnetic interference (EMI) standards.

The RAID controllers, expansion adapters, disk drives, power supplies, and the LAN card are hot-swappable field replaceable units (FRUs), which means you can add or replace them while the PFR 700 Series is powered up.

IMPORTANT: You must not hot swap operational RAID controllers or disk drives without first disabling the target component using the Grass Valley Disk Utility.

An optional second RAID controller module in the PFR700 Series, allows for continued access to the PFR 700 Series if the primary RAID controller fails. Adding a second RAID controller to the same chassis is not intended to increase performance, but rather to add redundancy. Refer to your Profile XP PVS Series Installation Guide for detailed connection and configuration instructions.

The following figure shows the RAID Storage Chassis components. Details on each component follow the figure.

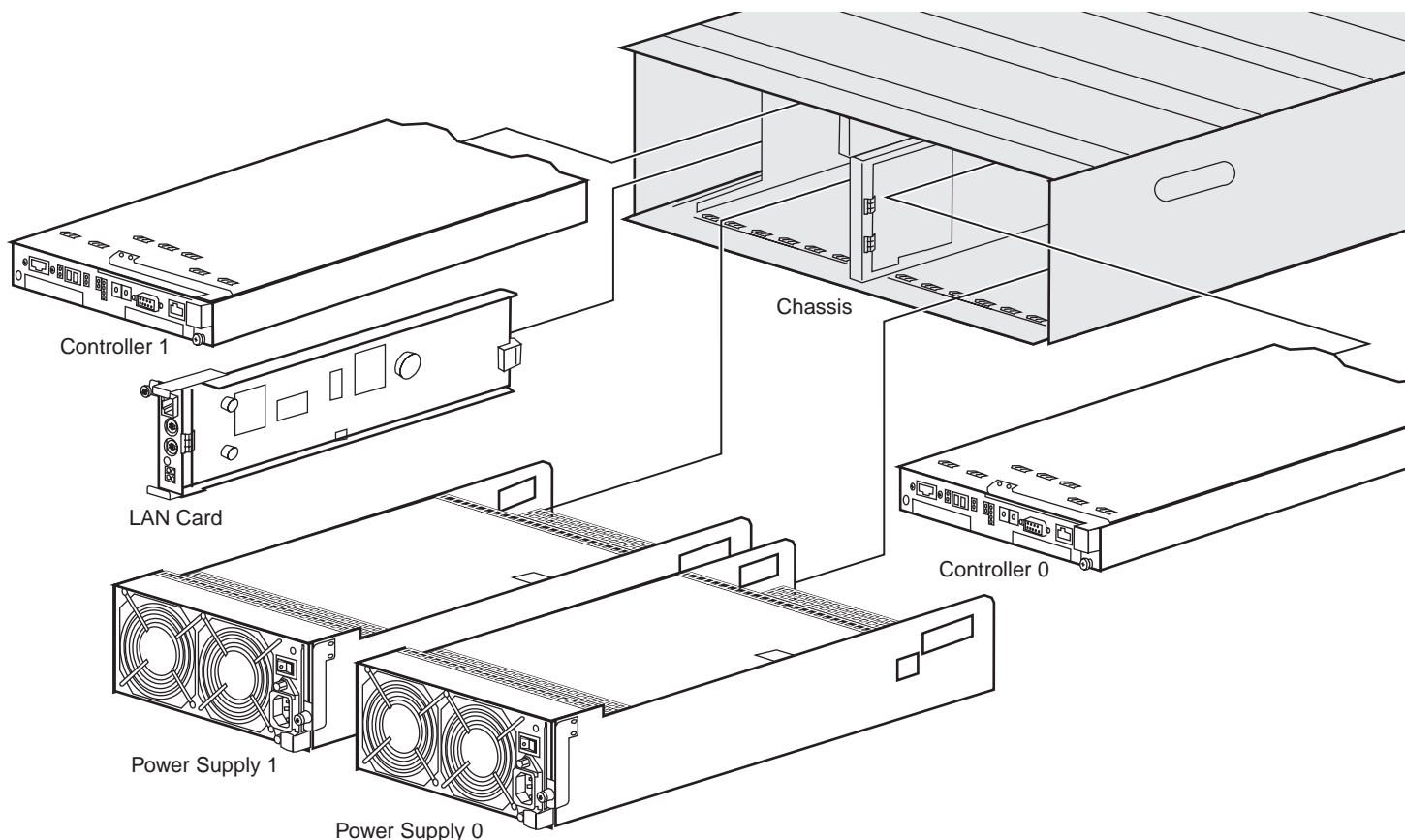

NOTE: Every PFR700 Series RAID chassis power supply includes a backup battery so that if electrical power is lost, data stored in cache memory will be saved. Data store cache is not used in the PFR700 Series, so the Battery Backup module is not used, even though it ships as part of the power supply.

Chassis

The chassis is a sheet-metal housing which contains a passive midplane and chassis slots for the RAID controllers or expansion adapters, disk drives, power supplies, and the LAN card.

A RAID chassis (which houses one or two RAID controllers) has a pre-set chassis address of 0. An expansion chassis (which houses one or two expansion adapters) must have its chassis address set to 1. This address is set by a control on the expansion adapter. Refer to your *PVS Series Installation Guide* or the *Open SAN Installation Manual* for information on setting the chassis address switch. See also, [“Addressing requirements” on page 25](#).

The following diagram shows how disk modules are identified based on the chassis address and physical location. The chassis with an address set to 0 contains drives from 0 to 14; the expansion chassis with an address set to 1 contains drives from 16 to 30. There is no drive 15 in the numbering sequence.

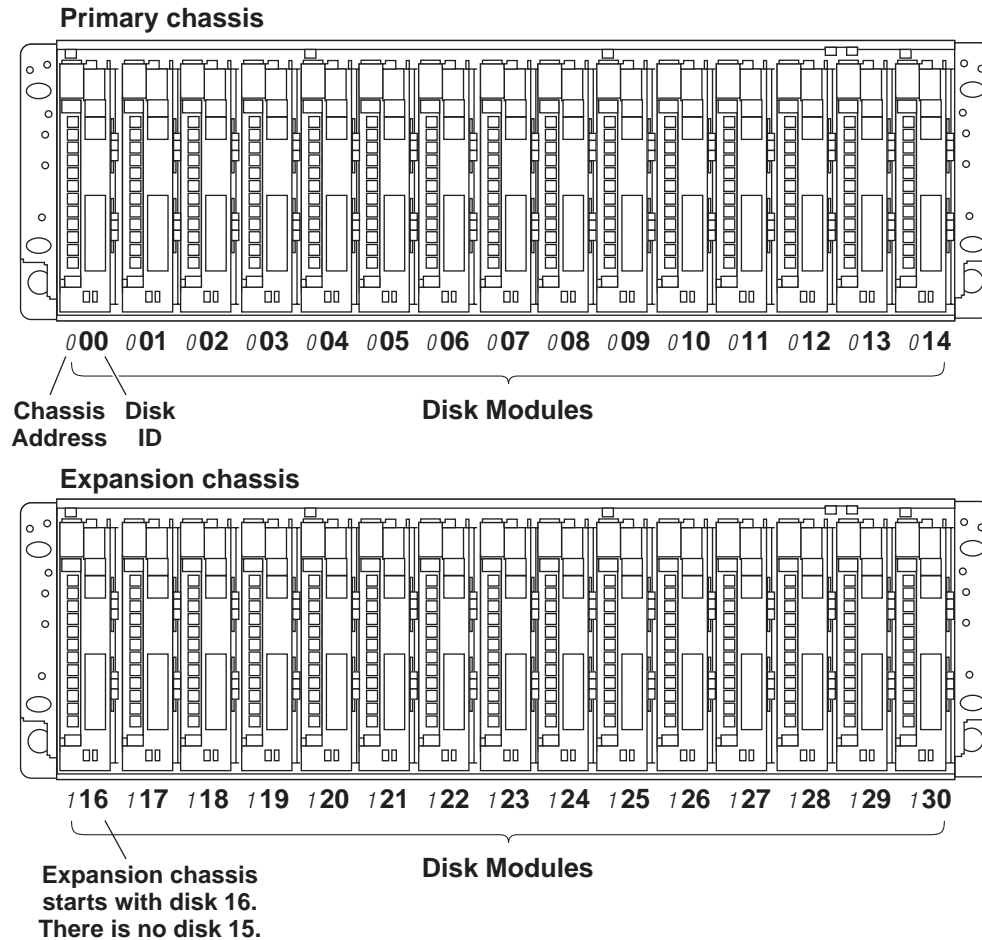

An operating primary RAID chassis must have, at a minimum, the first three physical drives (0 - 2) installed, as the RAID configuration information is written to these drives. Microcode is also written to these disks when RAID controller microcode is loaded.

Midplane

The midplane distributes power and signals to all the chassis components. All FRUs plug directly into midplane connectors.

Disk modules

Each disk module consists of a Fibre Channel disk drive in a carrier assembly. If a disk drive fails, and needs replacing, you can do so while the RAID Storage Chassis is powered up. Replacement disk drives begin rebuilding immediately after being installed. (See [“Removing and installing disk modules”](#) on page 45.)

The disk drives are 3.5-inch FC-AL drives that conform to the Fibre Channel Arbitrated Loop (FC-AL) standards and support dual-port FC-AL interconnects through the two RAID controllers and their cabling.

⚠ NOTE: *Once the PFR700 Series RAID is installed and configured, the disk modules become slot dependent. Moving disk modules between physical slots will result in loss of data and the need to reconfigure the system.*

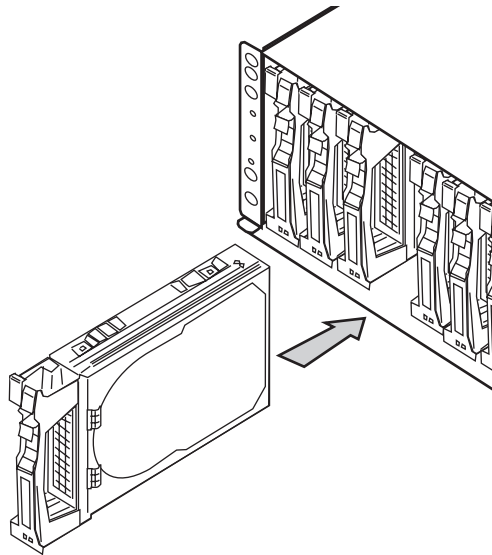

PFR 700/E Circuit board modules

There are three circuit board modules used: the RAID controller module, the expansion adapter, and the LAN card. The RAID controller module is in the primary RAID chassis. It manages the disk drives and provides a Fibre Channel interface to the Profile system or Fibre Channel switch fabric. The expansion adapter is in an Expansion chassis. It manages the disk drives, in conjunction with the connected RAID controller, and provides a Fibre Channel interface to the primary chassis. The LAN card is in the primary RAID chassis only. It provides an Ethernet port for NetCentral monitoring, a shutdown switch, and signal connections for an uninterruptive power supply (UPS).

PFR700 RAID Storage Chassis circuit board modules

The PFR 700 includes one or two RAID controller modules. Two RAID controller modules are installed when the redundant Fibre Channel option is installed. This provides redundant Fiber Channel interface ports to the Profile system or Fibre Channel switch fabric.

The following figure shows a PFR 700 RAID Storage Chassis with the two RAID controller modules installed.

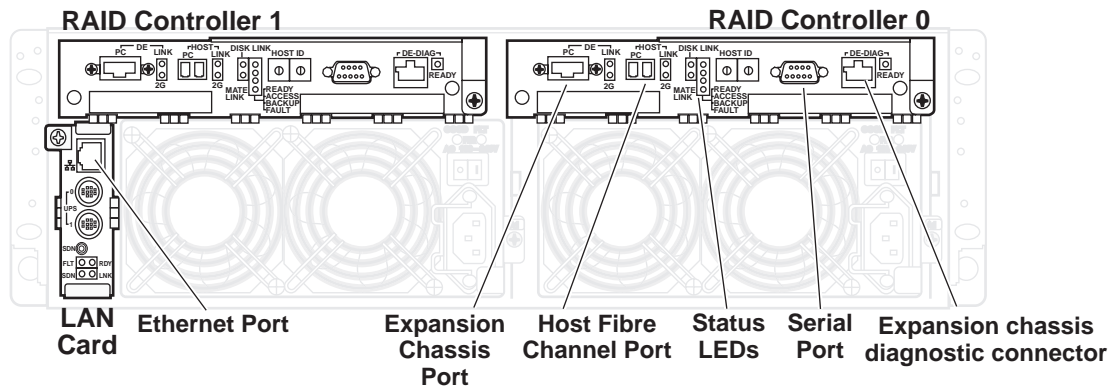

The RAID controller module has two Fibre Channel ports: the Host Fibre Channel Port and the Expansion Chassis Port. The Host Fibre Channel Port requires LCC cables (optical) for the Fibre Channel connection to a Profile XP Media Platform or to a Fibre Channel switch in an Open SAN fabric, respectively. The Expansion Chassis Port requires HSSDC cables (copper) for the Fibre Channel connections with a PFR 700E. This extends the Fibre Channel loop of the corresponding PFR 700 chassis. There is a port status LED for each Fibre Channel port. Refer to [“Interpreting controller status LEDs” on page 41](#).

When the redundant Fiber Channel option is not installed in the PFR 700 RAID Storage Chassis, only one RAID controller is installed. A blank fills the other RAID controller slot.

A diagnostic cable is provided for communication of system status information between the RAID controller and an expansion adapter. This is required, and it supports the NetCentral monitoring software. Refer to your *PVS Series Installation Guide* or the *Open SAN Instruction Manual* for information how these connectors are used.

The PFR 700 includes a LAN card with an RJ-type connector for Ethernet network connection. It is through this connection that SNMP status information is communicated, for monitoring by the NetCentral system.

PFR700E RAID Expansion Chassis circuit board modules

The PFR 700E RAID Expansion Chassis has two expansion adapters as shown in the following figure.

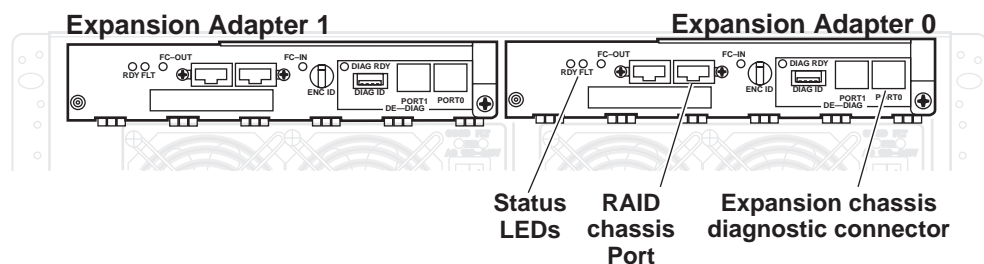

The expansion adapter in the PFR700E has two Fibre Channel ports: FC-IN and FC-OUT. HSSDC (copper) Fibre Channel cabling connects the FC-IN port to a PFR700. This extends the Fibre Channel loop of the corresponding PFR700 chassis. There is a port status LED for each Fibre Channel port. Refer to [“Interpreting expansion adapter status LEDs”](#) on page 43.

An expansion chassis diagnostic connection is provided for communication of system status information between the RAID controller and an expansion adapter. This is required to use the NetCentral monitoring software. Refer to your *PVS Series Installation Guide* or the *Open SAN Instruction Manual* for information how these connectors are used.

NOTE: *The PFR700E Expansion chassis and PFR700 Controller chassis must be powered on and off in the proper sequence. Refer to proper power procedures in Chapter 2, “PFR700 Series Installation Information”.*

Power supplies

There are two auto-ranging power supplies, power cord and standby switch. Each supply supports a fully configured PFR700 Series RAID and shares load currents with the other supply, if it is present. The power supplies are designed so as to protect the disk drives if you install them while the PFR700 Series RAID is powered up. A disk with power-related faults will not adversely affect the operation of any other disk.

The RAID chassis and the expansion chassis each have their own type of power supply. The two types are not interchangeable.

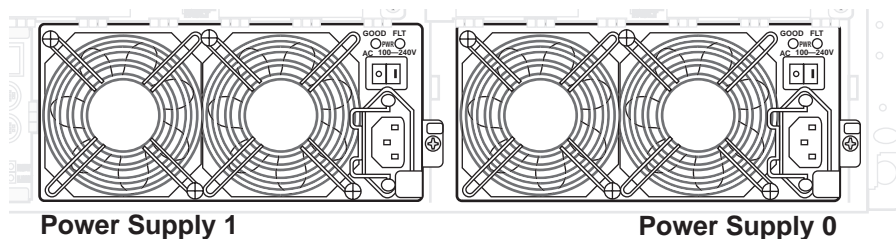

Each power supplies includes two fan modules used to cool the components installed in the PFR700 Series RAID chassis. Each power supply has status LEDs visible from the rear panel. The status LEDs are described in the [“Interpreting power supply status LEDs”](#) on page 45. You can add or remove one power supply in the RAID Storage Chassis while the RAID Storage Chassis is powered up.

Configurations

The RAID Storage Chassis minimum and maximum configurations are as follows.

PFR 700 Configuration	RAID Controllers	Power Supplies	Disk Modules	LAN Cards
minimum	1	2	5	1
maximum	2	2	15	1

The maximum configuration provides the most redundancy, and therefore the highest degree of system availability.

The PFR 700E RAID Expansion Chassis minimum and maximum configurations are as follows.

PFR700/E Configuration	Expansion Adapter	Power Supplies	Disk Modules	LAN Cards
minimum	2	2	5	0
maximum	2	2	15	0

IMPORTANT: Grass Valley does not support mixing disk drives of differing capacities in any RAID chassis. All disk drives in any RAID chassis must be of the same capacity. For example, if a PFR 700 and a PFR 700E are connected, all the disk drives in both the PFR 700 and the PFR 700E must be of the same capacity.

PFR 700 Series Installation Information

This chapter describes information you'll need to install the PFR 700 Series Fibre Channel RAID Storage Chassis (PFR 700/E). Major topics are:

- [“Installation requirements”](#)
- [“Installing a PFR 700/E in an equipment rack”](#)
- [“PFR 700/E power-up and initialization”](#)
- [“PFR 700/E power-down”](#)

Installation requirements

This section describes the following requirements:

- [“Site requirements” on page 23](#)
- [“Controller configuration requirements” on page 24](#)
- [“Addressing requirements” on page 25](#)
- [“Cabling requirements” on page 28](#)
- [“Binding disk modules into groups” on page 29](#)

Site requirements

For proper PFR 700/E operation, the installation site must conform to certain environmental specifications. These are detailed below and in [Chapter 4, PFR 700 Series Technical Specifications and Operating Limits](#).

Power

Refer to [“AC power requirements” on page 59](#) for AC power requirements. The values indicate either the values for the power cord of a PFR 700/E with a single power supply, or the total values shared by the line cords of two power supplies in the same PFR 700/E, with the division between the power cords and supplies at the current sharing ratio. If one of the two power supplies fails, the remaining supply and cord must support the full load. You must use a rack mount cabinet with ac power distribution, and have main branch ac distribution that can handle these values for the number of PFR 700s and PFR 700Es that you will interconnect.

Cooling

Make sure your site has air conditioning of the correct size and placement to maintain the specified ambient temperature range. The air conditioning must be able to handle the requirements of the PFR 700s and any connected PFR 700Es as indicated under [“Environmental limits” on page 60](#).

Controller configuration requirements

The default settings for the controller DIP switches are shown in the following illustrations and table. Remove the controller, as explained in [“Replacing a RAID controller or expansion adapter” on page 48](#), and verify that the default settings are intact.

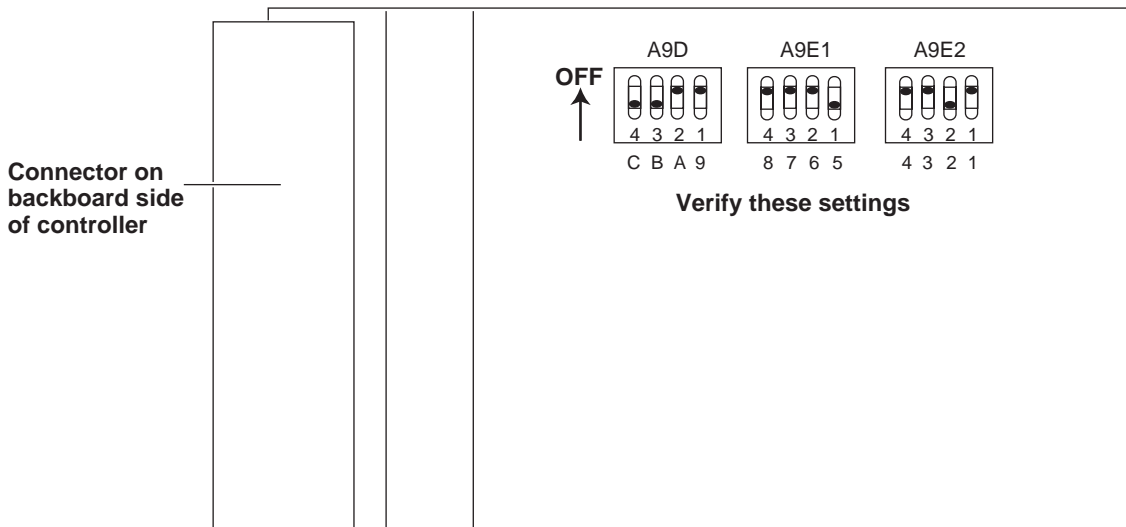
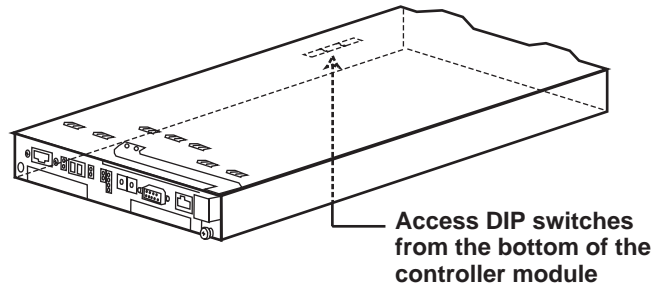

Switch position	Bit position	Setting position and function
A9E2	1	Fixed to OFF (HDD Spin-up Mode, OFF: Command, ON: Auto)
	2	Fixed to ON (Operation Mode, OFF: NF1200, ON: NF1300)
	3	OFF by default (Topology, OFF: FC_AL, ON: Fabric)
	4	Fixed to OFF (MD Mode, OFF: Normal, ON: Long MD)
A9E1	5	Fixed to ON
	6	Fixed to OFF
	7	Fixed to OFF
	8	Fixed to OFF

Switch position	Bit position	Setting position and function
A9D	9	Fixed to OFF
	A	Fixed to OFF (SES MODE, OFF: SFF8067, ON: ESD)
	B	ON by default (HOST MODE, OFF: 1Gbps, ON: 2Gbps)
	C	ON by default (EXPANSION CHASSIS MODE, OFF: 1Gbps, ON: 2Gbps)

Addressing requirements

There are two addresses for the PFR 700: the Fibre Channel Arbitrated Loop address ID (FC-AL address ID) and the chassis address.

FC-AL address ID

Each node (such as a RAID controller) on the Fibre Channel front-end loop must have a unique FC-AL address ID. The FC-AL protocol translates the FC-AL address ID into an 8-bit arbitrated loop physical address (ALPA). You set the RAID controller FC-AL address ID using switches, as explained later in this chapter. The PFR700 does not allow an ID of zero. If your PFR 700 has a second, redundant RAID controller, it must be set to a different FC-AL address ID than the primary FC.

When using redundant RAID controllers, set the FC-AL ID on the controllers for all PFR 700s connected as indicated in the following table.

Number of PFR 700s	PFR 700 chassis	Primary Controller (0) FC-AL ID	Redundant Controller (1) FC-AL ID
1	First	1	2
2	First Second	1 2	3 4
3	First Second Third	1 2 3	4 5 6

The valid FC-AL address ID range is a number 1 through 125 decimal, which is 01 through 7D hexadecimal. The following figures and table locate the switches and show how to select ID numbers using them.

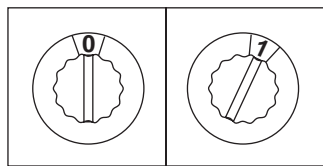
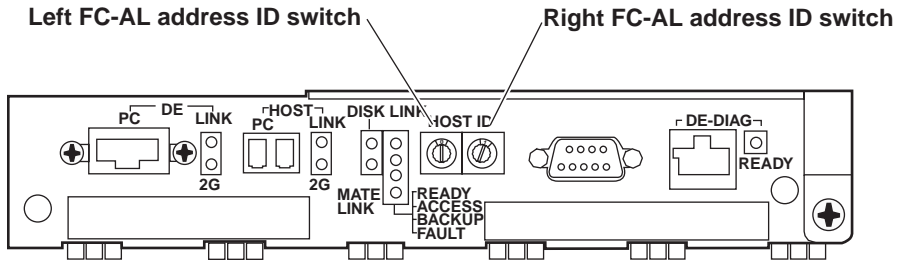

Address ID = 1

Address ID	Left Switch	Right Switch
1	0	1
2	0	2
.	.	.
.	.	.
9	0	9
10	0	A
11	0	B
.	.	.
.	.	.
15	0	F
16	1	0
17	1	1
.	.	.
.	.	.
25	1	9
26	1	A
27	1	B
.	.	.
.	.	.
31	1	F
32	2	0

Chassis address setting requirement

The chassis address for a PFR700 primary RAID chassis is pre-set at 0 and does not need to be configured.

Each PFR700E expansion chassis must have its chassis address set to 1, which is the factory-set value. This is set by the chassis address switch, which is located on the expansion adapter. The following figure identifies the switch.

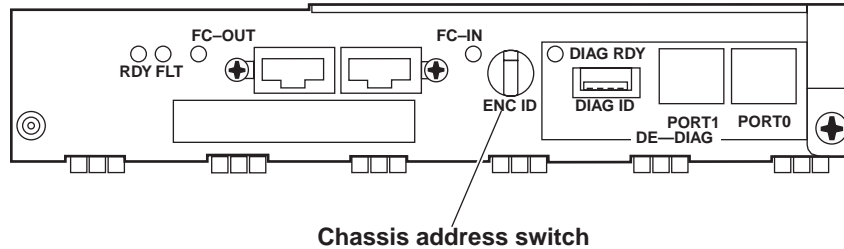

Set the switch to 1 for both the left and right expansion adapters installed in the Expansion chassis.

NOTE: When the switches of the left and right adapters are set differently, the FAULT LEDs blink and the Expansion chassis is not started. If different values are set, turn off the power of the system including the Expansion chassis, re-set the values to 1, and turn on the power again.

Expansion chassis diagnostic switch setting requirement

A PFR700 primary RAID chassis has no expansion chassis diagnostic switch, so no configuration is necessary.

The expansion chassis diagnostic ID switch sets the diagnosis path address of the Expansion chassis. This is required for NetCentral monitoring. Each PFR700E expansion chassis has the switch that must be set to 0, which is the factory-set value. The expansion chassis diagnostic switch is located on the expansion adapter. The following figures show how to use the switch.

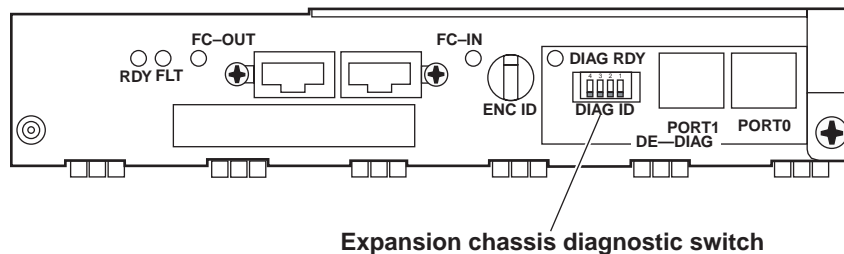

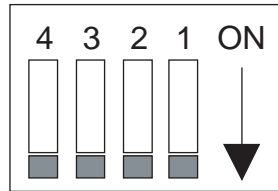

ID = "0"

Set the switch to **0** for both the left and right expansion adapters installed in the Expansion chassis.

Cabling requirements

It is recommended that you use the Fibre Channel cables shipped with your PFR 700/E when making connections. For cable specifications, refer to [“Cable lengths” on page 59](#).

Optical cables must meet the appropriate 2-Gbit FC-AL loop standards. You must use this type of cable to connect a host to the PFR 700 controller.

Copper cables must meet the appropriate standards for 2-Gbit FC-AL loops. You must use this type of cable to connect Expansion chassis.

PFR 700 and PFR 700E interconnections should maintain consistency. That is, one FC loop should connect the PFR 700’s RAID controller 0 and the PFR 700E’s expansion adapter 0. The other FC loop should connect the PFR 700E’s RAID controller 1 and the PFR 700E’s expansion adapter 1. If your PFR 700 does not have RAID controller 1, do not connect any cabling to the PFR 700E’s expansion adapter 1.

Do not leave an unused (that is, dangling) cable connected to a Fibre Channel port because it may cause excess noise on the loop.

Diagnostic cables connect PFR 700 and PFR 700E units. These cables are required for the communication of status information between chassis, and support NetCentral monitoring.

NOTE: Also refer to the PVS Series Installation Guide you received with your Profile XP storage system or the Open SAN Instruction Manual for cabling diagrams and step-by-step instructions.

Binding disk modules into groups

After cabling a PFR 700 and any PFR 700Es, you must bind disk modules into LUNs using a GVG Disk Utility provided by Grass Valley. Refer to the appropriate manual for information on using the GVG Disk Utility to bind drives.

NOTE: Make sure you allow adequate time for binding disk modules into LUNs. PFR500 and PFR600 controllers bind each LUN in turn, but take less than a minute for each LUN. PFC500 and PFR700 controllers bind multiple LUNs at the same time, yet take more than an hour to bind a LUN. Large drive capacities and multiple LUNs can increase the binding time to 10 hours or more.

Type of PFR700/E installation	Manual to use for binding procedures
Part of an Open SAN	<i>Open SAN Instruction Manual and Release Notes</i>
Connected directly to a Profile XP Media Platform as local storage	<i>PVS Installation Guide</i> (for your Profile XP model) or the <i>Profile XP System Guide and Release Notes</i>

Installing a PFR 700/E in an equipment rack

Use the information in this section to unpack the PFR 700/E chassis and mount in an equipment rack.

Procedures include:

- “Unpacking the chassis”
- “Installing the rack mounts”
- “Inserting the PFR 700/E chassis in the rack”

Unpacking the chassis

Unpack the PFR 700/E chassis, cables, and installation kit, as illustrated by the diagram on the outside of the packing box.



NOTE: A PFR 700/E chassis is heavy. Two people should lift and move it.

NOTE: Save the chassis packaging. Use only PFR 700 approved packaging to ship.

Installing the rack mounts

The following diagram and procedure describe installing the right side rail. Installation is similar for the left side rail.

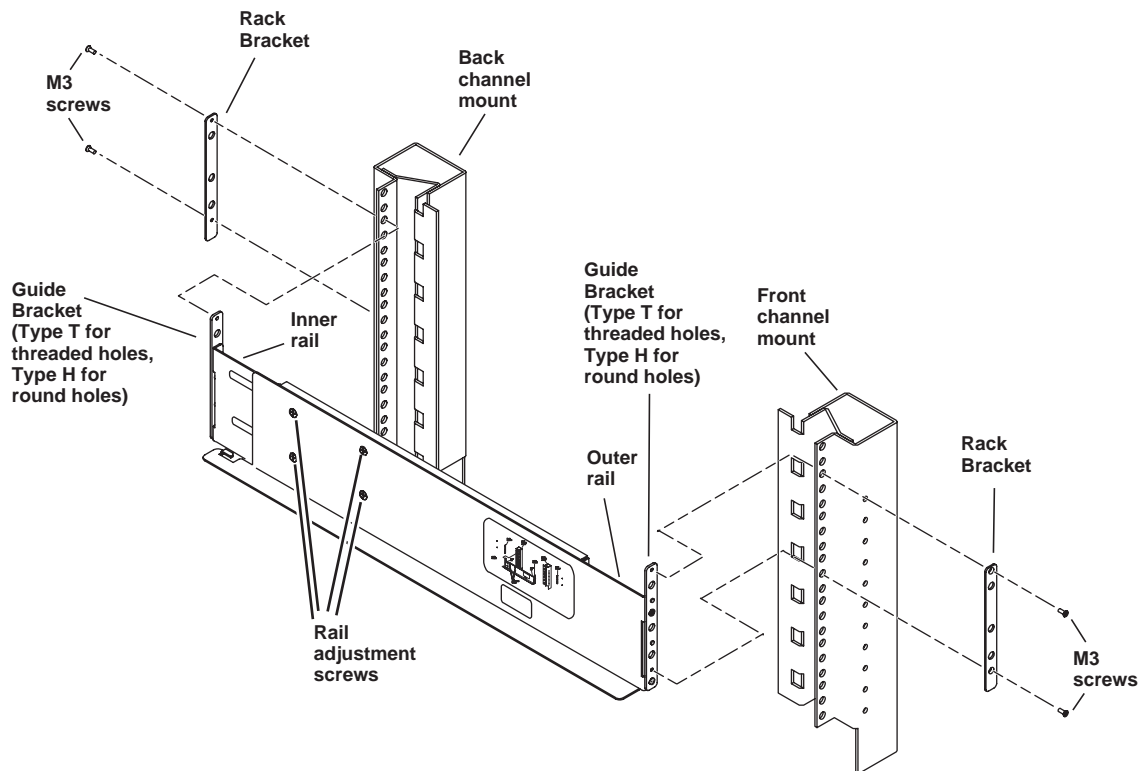

To install the PFR 700/E rack mounts:

1. Remove the rack brackets from the guide brackets at both ends of the rail. Save the rack brackets and the M3 screws, as they are used later in this procedure.

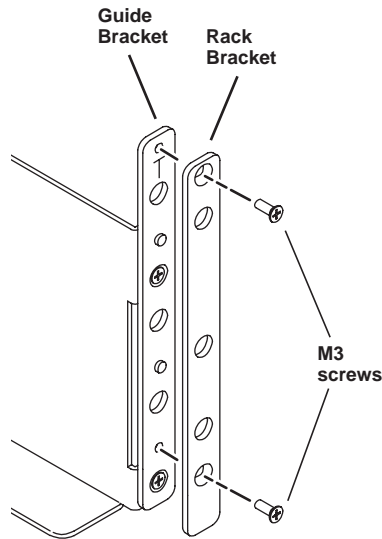

2. If your rack has 10-32 threaded holes, skip ahead to the next step in this procedure. If your rack has 0.281-inch round holes, at both ends of the rail replace the T type guide brackets with the H type guide brackets.

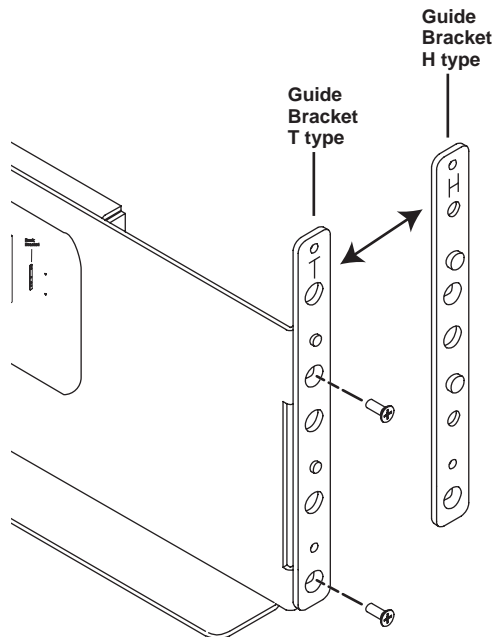

3. Loosen the rail adjustment screws so that the inner rail slides freely.

4. Align the mounting holes on the outer rail guide bracket with the front channel mount holes. The protrusions on the guide bracket guide the rail to appropriate positions on the rack.
5. Place the two M3 mounting screws through the rack bracket, through the front channel mount holes, and into the mounting holes on the guide bracket. Tighten the screws to secure the outer rail to the front channel mount.
6. Move to the rear of the rack and pull the inner rail toward you to align the inner rail guide bracket mounting holes with the back channel mount holes. The protrusions on the guide bracket guide the rail to appropriate positions on the rack.
7. Place the two mounting screws through the rack bracket, through the back channel mount holes, and into the mounting holes on the guide bracket. Tighten the screws to secure the outer rail to the back channel mount.
8. Firmly tighten the rail adjustment screws.
9. Repeat this procedure for the other side rail.

Inserting the PFR700/E chassis in the rack

1. Rest the chassis on the support angles shown. Slide the chassis back and into place
2. Secure the chassis to the rack with the 10-32 mounting screws. On racks with threaded holes the mounting screws engage the rack's threaded holes. On racks without threaded holes the mounting screws engage the H type guide bracket's threaded holes.

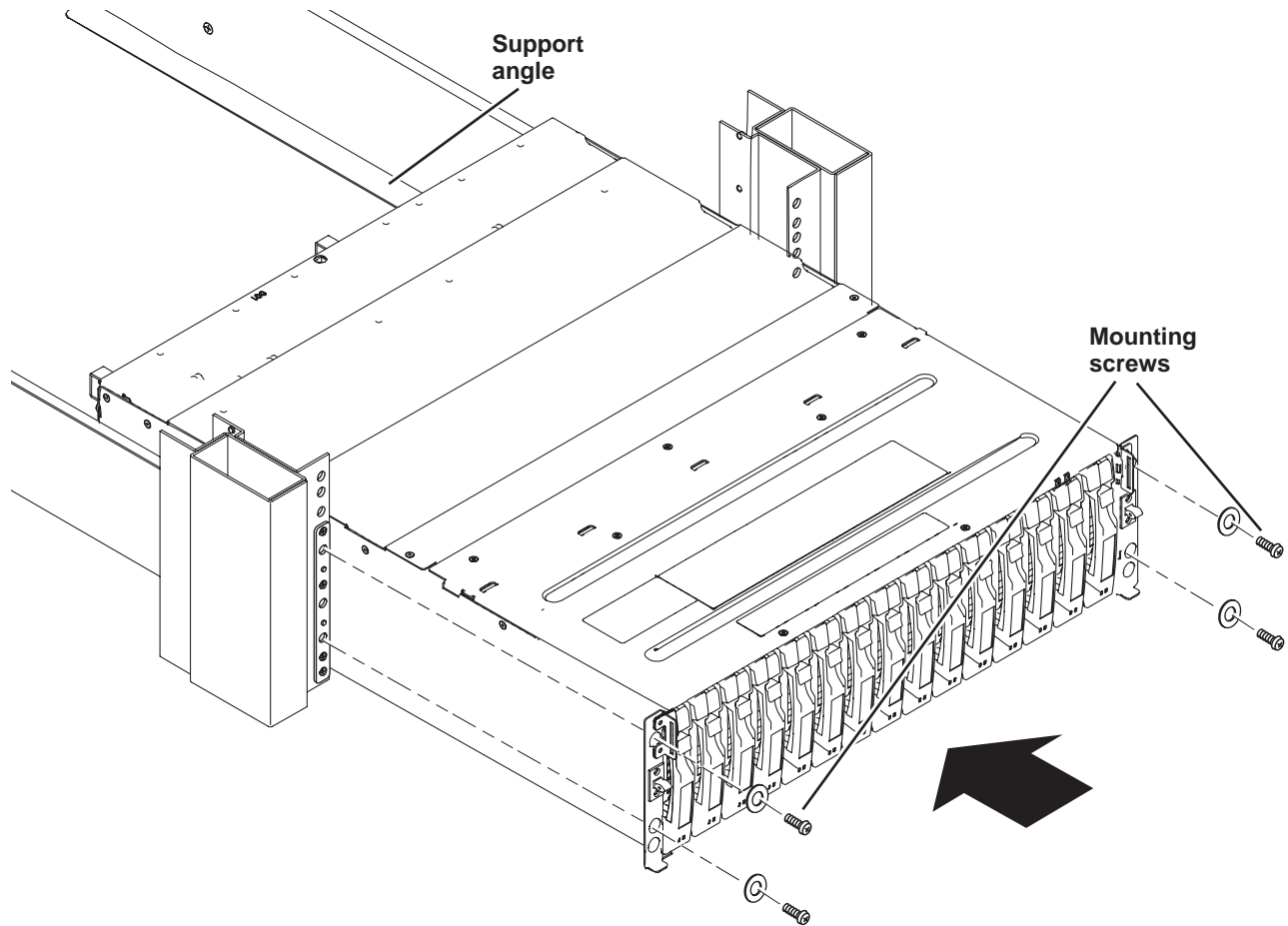

3. At the rear of the rack, insert and tighten the 10-32 mounting screws, with cable clamps, through the rear rack brackets. On racks with threaded holes the mounting screws engage the rack's threaded holes. On racks without threaded holes the mounting screws engage the H type guide bracket's threaded holes.

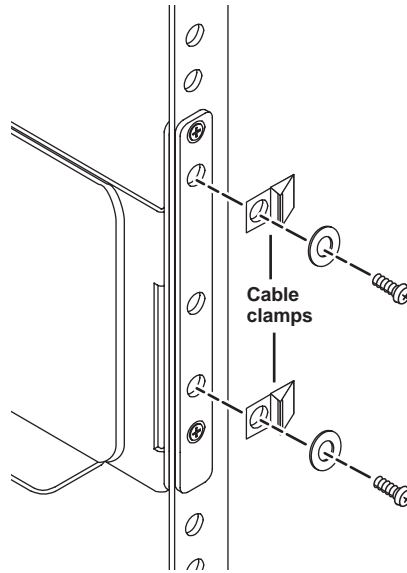

The 10-32 screws in the rear provide necessary reinforcement to the M3 screws.

4. Repeat this procedure to insert each PFR700/E chassis in the rack.

PFR 700/E power-up and initialization

This section gives information about connecting power and powering-on the PFR 700/E system.

Connecting electrical cables

For each chassis, there are two electrical cables (one for each power supply) which should be connected to separate outside power sources.



WARNING: Make sure the power cords meet local safety and electrical standards.



CAUTION: The PFR700/E system must be electrically grounded. Operating the system without proper grounding can damage disk drives. If the outlet you use is not grounded, make sure that a licensed electrician replaces it and installs a grounding conductor.

To prevent the plug from being inadvertently disconnected, secure the electrical cable into the outlet by doing the following:

1. Check that the power switch on the RAID chassis and those on the host system are all set to OFF.

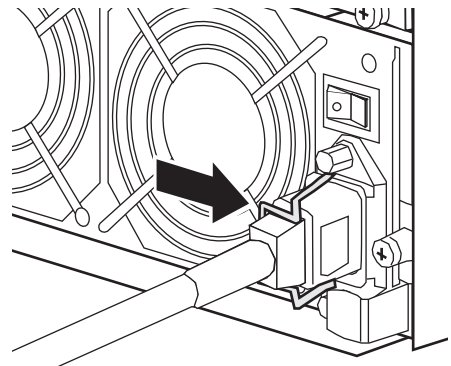
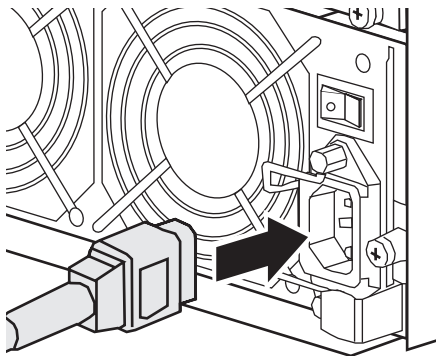

2. Insert the power cord into the power supply.
3. Secure the power cord with the stopper.
4. Insert the plug of the power cord into an AC outlet. Use a grounded AC outlet.

Powering-up the PFR 700/E system

1. Power-up the PFR 700E Expansion chassis prior to, or at the same time as the PFR 700 Controller chassis.

NOTE: You must always power-up the PFR700E Expansion chassis prior to, or at the same time as the PFR700 RAID controller chassis. Failure to do so may prevent some LUNs in the expansion chassis from being recognized.

Before turning on the AC power, check for loose disk drives by pushing each disk drive.

2. Turn on power switches on both power supplies.

When turning on the power switches, confirm that the POWER GOOD LEDs (green) on all the power supplies and POWER LEDs (green) on the front panel of the RAID chassis and Expansion chassis go on. The power supply starts, and the POWER LED (green) is on while the power switches are on.

The RAID chassis performs the self-test and initialization immediately after the power is turned on. When the self-test and initialization terminate and the RAID chassis becomes ready, the READY LED of the controller stops flashing and enters the on state.

3. Confirm that the READY LED is on, and then turn on the host system.

The chassis takes four minutes (at maximum) to start.

Refer to sections in [Chapter 3, “Servicing the PFR700 Series RAID”](#) for information on interpreting status LED behavior.

NOTE: Refer to the *Profile XP System Guide* or *Open SAN Instruction Manual* for complete system power-up procedures.

PFR700/E power-down

NOTE: If your PFR700/E system is part of an Open SAN, refer to the *Open SAN Instruction Manual* for instructions on shutting down the Open SAN before powering down a PFR700/E.

To power-down the PFR700/E correctly:

1. Stop all read/write activity to the PFR700/E storage system.
2. On the RAID controller chassis, turn off power switches on both power supplies.
3. On the Expansion chassis, turn off both power switches on both power supplies.

Alternatively, turn off all power switches of the RAID controller chassis and the Expansion chassis at the same time.



CAUTION: You must always power down the PFR700 RAID controller chassis prior to, or at the same time as the PFR700E Expansion Chassis.

To turn on power, refer to [“PFR700/E power-up and initialization”](#) on page 35.

Battery Backup

Every PFR700 RAID chassis power supply includes a backup battery so that if electrical power is lost, data stored in cache memory will be saved.

Data store cache is not used in Profile storage systems, so the Battery Backup module is not used, even though it ships as part of the power supply module.

Servicing the PFR700 Series RAID

This chapter describes how to monitor PFR 700 Series RAID status and replace Field Replaceable Units (FRU).

Topics include:

- “Maintenance procedures using GVG Disk Utility” on page 37
- “Monitoring PFR700 Series RAID status using NetCentral” on page 38
- “Interpreting disk module LEDs” on page 40
- “Interpreting controller status LEDs” on page 41
- “Interpreting expansion adapter status LEDs” on page 43
- “Interpreting LAN card status LEDs” on page 44
- “Interpreting power supply status LEDs” on page 45
- “Removing and installing disk modules” on page 45
- “Replacing a RAID controller or expansion adapter” on page 48
- “Replacing the LAN card” on page 52
- “Replacing a power supply” on page 54

Maintenance procedures using GVG Disk Utility

Several maintenance procedures can be performed using the GVG Disk Utility installed on the Profile XP Platform for standalone storage, or on the FSM in Open SAN systems.

To perform the following tasks, refer to Chapter 3 of the *Profile XP System Guide*:

- Checking RAID controller microcode version
- Loading RAID controller microcode: All models
- Identifying disk modules prior to removal
- Downloading PFR 700 disk drive firmware
- Disabling a PFR 700 RAID controller for removal
- Disabling a PFR 700 disk module for removal
- Configuring PFR 700 network and SNMP settings

Monitoring PFR700 Series RAID status using NetCentral

You can monitor PFR700 Series RAID Storage systems using Grass Valley's NetCentral monitoring software. Enabled by SNMP, NetCentral can continuously monitor the storage system and send notifications if there is a problem. The SNMP agent software required for NetCentral monitoring resides on the RAID storage device itself. As a result, the PFR700 Series RAID appears in NetCentral as a standalone device rather than as a subsystem of the Profile XP Media Platform.

Communication with NetCentral takes place over the LAN card Ethernet port. To monitor the PFR700 Series RAID, you must connect network cabling, power on the system, then configure network and SNMP settings as described in the *PVS Series Installation Guide*.

If you have PFR700E expansion chassis, you must connect the diagnostic cabling, as it is required for NetCentral monitoring.

Refer to the *Profile XP Service Manual* for information on monitoring the PFR700 Series RAID with NetCentral.

Interpreting front panel LEDs

Use the following illustration and table to identify and interpret front panel LEDs

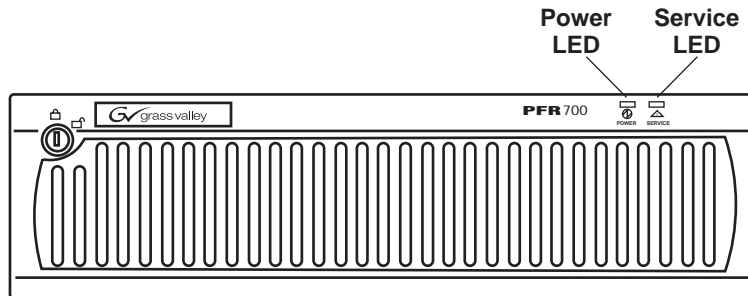

LED	Action	Meaning
Power	On	DC power is being supplied to the chassis.
	Off	DC power is not being supplied to the chassis.
Service	Flashing (check LEDs on modules to identify the specific fault)	Temperature alarm
		Less than three system disks
		A power supply, fan, battery backup unit, or controller is removed or is not detected as on-line.
		Controller down
		Controller powered-off
		Battery backup unit charging or is discharged.
		Fan alarm
		Power alarm
		Power supply off
		Hard disk drive fault
		Logic occluded
		Logic degraded
		Logic being restored
		Logic being restored to hot spare
Chassis is between power-on and ready state		
Rapid flashing		Device serial number, WWName, or ProductName is nonexistent or illegal. Waiting for input from panel.
		The configuration data in the system disk does not match the actual configuration.

Interpreting disk module LEDs

Use the following illustration and table to identify and interpret disk module LEDs

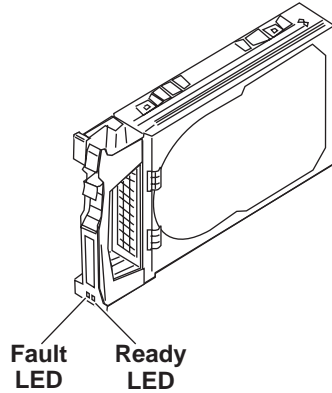

LED	Action	Meaning
Ready	On	Normal state. Ready.
	Off	Fault state
		Processing commands
	Flashing	Sending data
Self-test and initialization immediately after power-on		
Formatting		
Fault (amber)	Off	Normal state
	On	An error has occurred on the disk drive
	Slow flashing or off	Power turning off

Interpreting controller status LEDs

Use the following illustration and table to identify and interpret controller LEDs

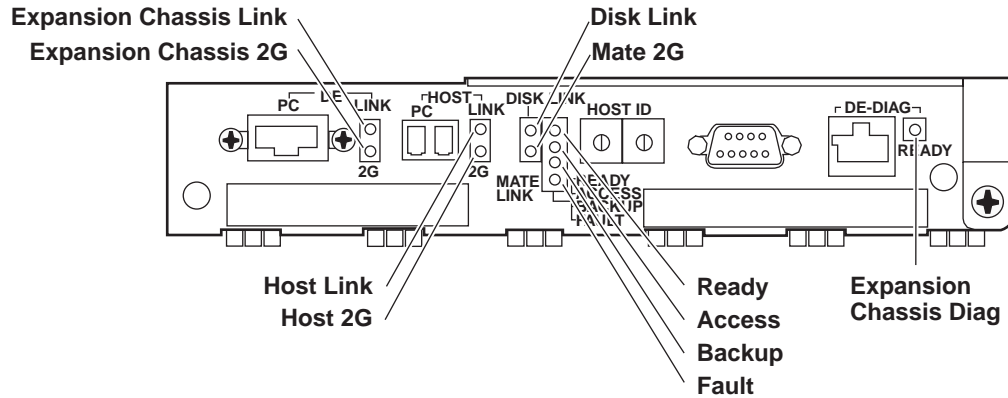

LED	Action	Meaning
Ready	On	Controller boot up complete
	Flashing	Controller booting up
Fault (orange)	On	Controller fault state
	Flashing	Controller cache sweep-out failed
Access	On	Controller commands are being executed via host or LAN card.
Backup (orange)	On (power off)	Controller memory backup state = Dirty data exists. Resources must not be replaced with new ones.
Host Link	On	The host Fibre Channel link is being executed.
	Off	Power on self test is being executed. Stays off if license key lock of Base Product is not released.
Host 2G	On	Interface with host is operating at 2Gbps.
	Off	Interface with host is operating at 1Gbps.
Expansion Chassis Link	On	The expansion chassis Fibre Channel linkup is being executed
	Off	Power on self test is being executed.
Expansion Chassis 2G	On	Interface with the disk is operating at 2Gbps.
	Off	Interface with the disk is operating at 1Gbps.
Disk Link	On	The internal disk channel linkup is being executed.
	Off	Power on self test is being executed.
Mate Link	On	The mate (redundant) controller linkup is being executed
	Off	Power on self test is being executed.

LED	Action	Meaning
Expansion Chassis Diag	On	Chassis is ready to diagnose.
	Off	Chassis is preparing for diagnosis.

Interpreting expansion adapter status LEDs

Use the following illustration and table to identify and interpret expansion adapter LEDs

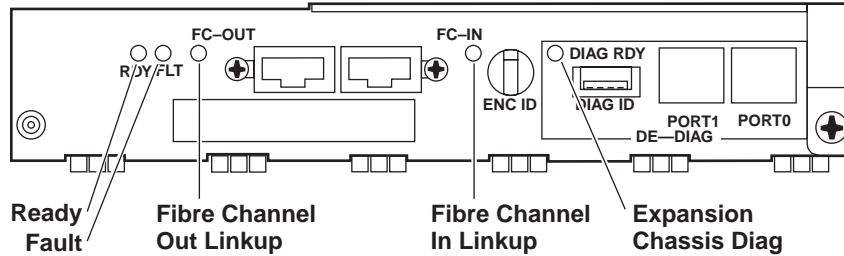

LED	Action	Meaning
Ready (Green)	On	Module is powered on and initial diagnostics completed normally
Fault (Orange)	On	Fault in the module. Also on at power-on and then off at the completion of the self-test.
Fibre Channel In Linkup	On	Fibre Channel In port (from primary RAID chassis) is operable and linked up.
	Off or flashing	Self-test or initialization just after power-on.
Fibre Channel Out Linkup	On	Fibre Channel Out port is operable and linked up. This port is not used.
	Off or flashing	Self-test or initialization just after power-on.
Expansion Chassis Diag	On	The expansion chassis is connected with the primary RAID chassis through the diagnostic cable and ready for diagnosis.
	Flashing	The LED blinks just after power-on or when no expansion chassis diagnosis cable is connected.

Interpreting LAN card status LEDs

Use the following illustration and table to identify and interpret LAN card LEDs

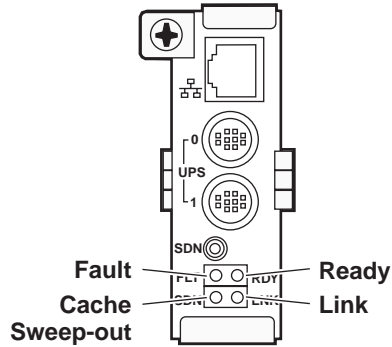

LED	Action	Meaning
Ready	On	Boot up complete
	Flashing	Waiting for setup of initial values
Fault (orange)	On	Initialization is occurring. (LED on temporarily only)
		Fault state
	Flashing	The LAN card is faulty While scheduled stop is executed, the unit (except LAN card) on which Fault LED is on, is faulty.
Link	On	Data is sent and received on the network.
Cache Sweep-out	On	Cache sweep-out complete. (Scheduled stop normally terminated and ready to power off)
	Flashing	Cache sweep-out in progress. (Scheduled stop is being executed, and no I/O interrupt from host is accepted)

Interpreting power supply status LEDs

Use the following illustration and table to identify and interpret power supply LEDs

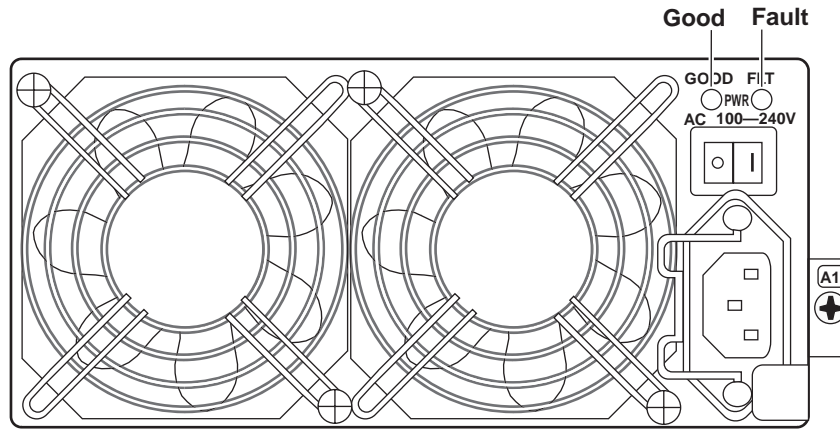

LED	Action	Meaning
Good	On	AC power is supplied to the chassis
Fault (orange)	On	Fault in power supply, battery backup unit, or fan

Removing and installing disk modules



CAUTION: If the RAID chassis does not have the redundant controller option, when a replacement disk module is inserted there can be a 1.5 second (maximum) disruption of video (record/play).

Use the following instructions to replace a faulty disk module. It should be replaced while the RAID chassis is running (hot-swapped).

NOTE: Grass Valley does not support mixing disk drives of differing capacities within a RAID chassis connected to a Profile XP Media Platform or Open SAN. All disk drives in any RAID chassis must be of the same capacity. For example, if a PFR700 and a PFR700E are used, all the disk drives in both the PFR700 and the PFR700E must be of the same capacity.

Moving disk modules



CAUTION: You can destroy the media file system beyond recovery if you move a disk module to a different slot. The service person can move a disk module when you don't care about losing the media in the media file system and under the following cautions:

- The disk module must be unbound.
- Moving a drive module that is part of a LUN to another slot makes all information on the LUN inaccessible.
- You must remove and install the disk module while the storage system is powered up.

A disk module must be inserted all the way or removed entirely. Do not leave a disk module partially removed except for periods when you are allowing it to spin down. When replacing multiple disks, observe the following:

- The RAID chassis configuration information is written to the first three disk modules. If all of these disk modules are replaced with new devices with the power supplies turned off, the information is lost. This condition is indicated by the SERVICE LED blinking at a high rate at chassis power up. Therefore, do not replace the first three disk modules with the power supplies turned off.
- When multiple disk modules are subject to replacement, they must be replaced with new disk modules one by one. Do not replace multiple disk modules simultaneously. After checking that the Ready LED on the front panel of the current disk module is lit, commence replacing the next disk module.
- Stick on the physical label indicating the installation position on each newly installed disk module.
- If both disk modules in 16 and 29 (or 17 and 30) in the expansion chassis are defective or uninstalled, the Service LED on the expansion chassis and the Fault LED on the expansion adapter will go off. In this case, first install a sound disk module in 16 or 29 (or 17 or 30). If the expansion adapter operates normally, the Service LED on the expansion chassis and the Fault LED on the expansion adapter will go off.



CAUTION: Handle a disk module gently and use an ESD wristband. Do not remove a faulty disk module until you have a replacement module (with the same part number) or a filler module available.

Removing a disk module

NOTE: If a disk module has been bound into a LUN, do not move it to another slot unless you do not care about the data on the LUN. Each module has LUN identifying information written when it is bound. Moving it to another slot can make information on the original LUN inaccessible.

Generally, you should not remove a disk module unless it is faulty. Refer to [“Interpreting front panel LEDs” on page 39](#) and [“Monitoring PFR 700 Series RAID status using NetCentral” on page 38](#).

NOTE: If you wish to remove an operational disk module, use the *Grass Valley Disk Utility* to disable the disk before removing it.

To remove the disk module:

1. Confirm the location of the faulty disk module by checking its Fault LED. Also check NetCentral messages. NetCentral messages may report disk faults by disk

module number.

2. Remove the disk module as illustrated in the following diagram.

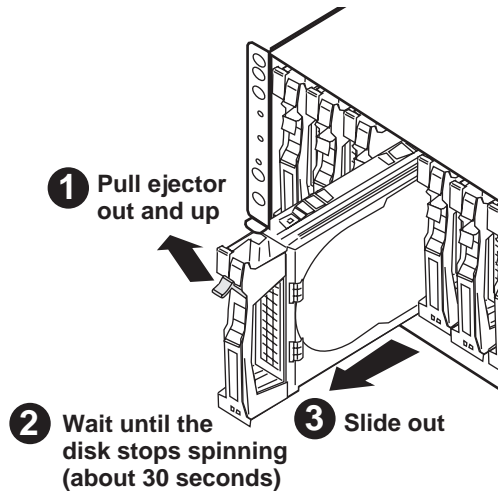

Installing disk module



CAUTION: *If the RAID chassis does not have the redundant controller option, when a replacement disk module is inserted there can be a 1.5 second (maximum) disruption of video (record/play).*

To install a disk module:

1. Wait at least three minutes after removing the previous disk module.
2. Put the a location label on the replacement disk drive, as appropriate for the slot into which it is installed.

3. Install the disk module as illustrated in the following diagram.

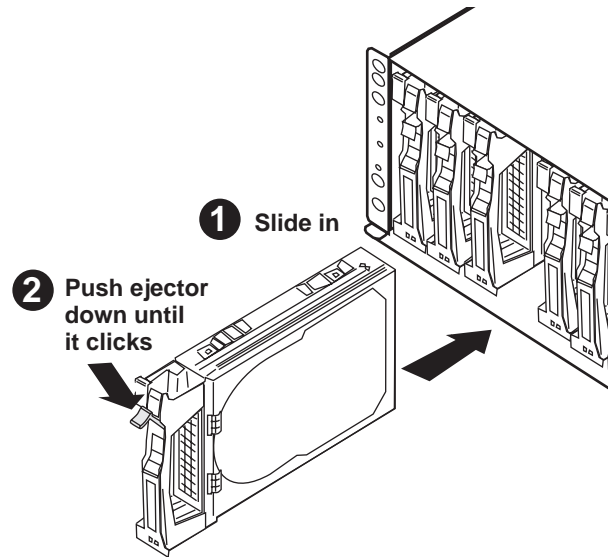

Upon installation the disk spins up automatically and data recovery begins.

Refer to “[Interpreting controller status LEDs](#)” on page 41 for disk module LED status during rebuild. Afterward, check disk module status using NetCentral or GVG Disk Utility.

Replacing a RAID controller or expansion adapter

Use the following instructions to replace a RAID controller or expansion adapter. It should be replaced while the chassis is powered up (hot-swapped).

NOTE: Ensure that the RAID controller module you are installing has the same microcode version as the module being replaced. Otherwise, the replacement module will not initialize. Refer to the Profile XP System Guide for information on checking controller firmware versions.

NOTE: A PFR700 Series RAID must have at least one RAID controller installed. Do not remove both RAID controllers, even in an offline condition. Since the controllers store the configuration information of the RAID chassis or the product license unlock information, replacing the two controllers simultaneously loses the data.

Removing a RAID controller or expansion adapter

To remove a RAID controller or expansion adapter:

1. Identify the module to be replaced using NetCentral or verify that the module’s Fault LED is on. If you are removing an operational RAID controller, use the GVG Disk Utility to disable the RAID controller.
2. Remove the cables connected to the module. Note where the cables connect to the module.

3. Loosen the ejector set screw.

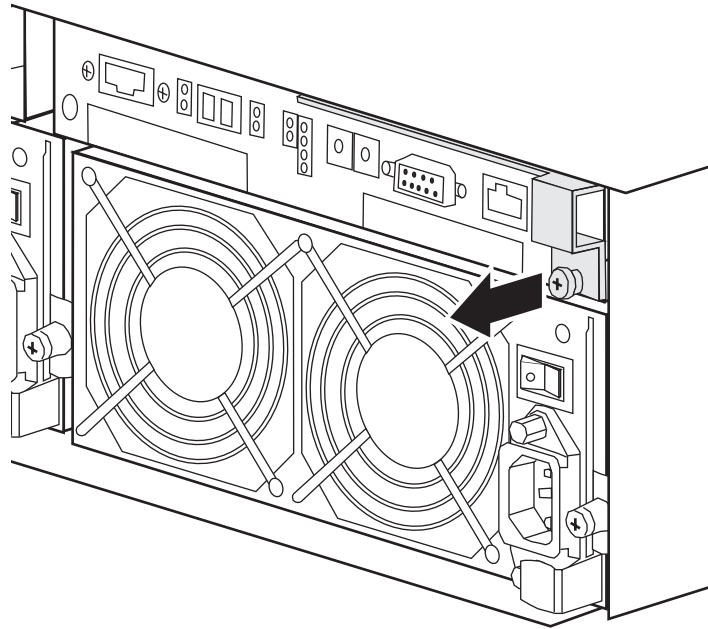

4. Remove the module as illustrated in the following diagram.

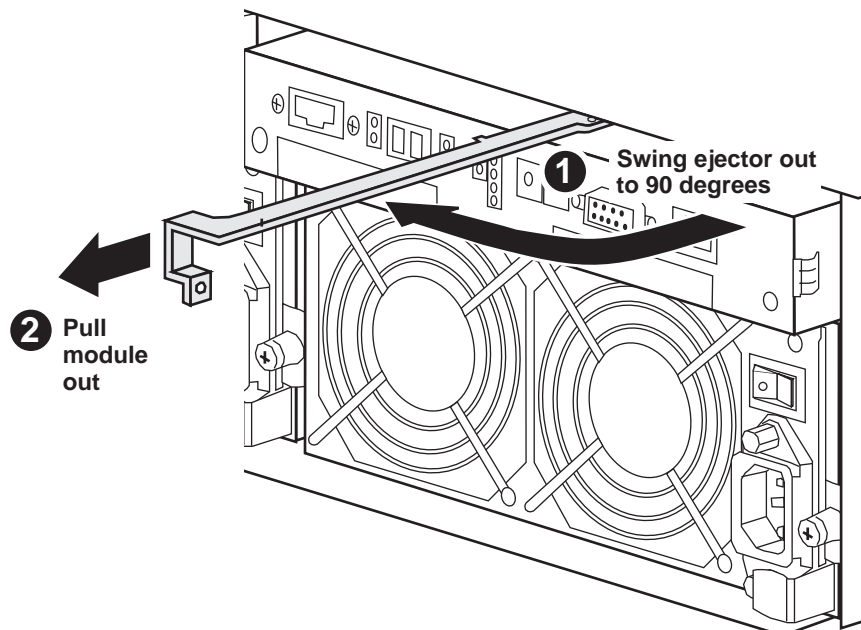

CAUTION: The module might be hot.

Installing a RAID controller or expansion adapter

To install a RAID controller or expansion adapter:

1. Set DIP switches the FC-AL switches on a replacement controller to be the same as that of the defective controller. Set the chassis address switch and the diagnostic switch on a replacement expansion adapter to be the same as that of the defective expansion adapter. For the switch locations, see [“Addressing requirements” on page 25](#).

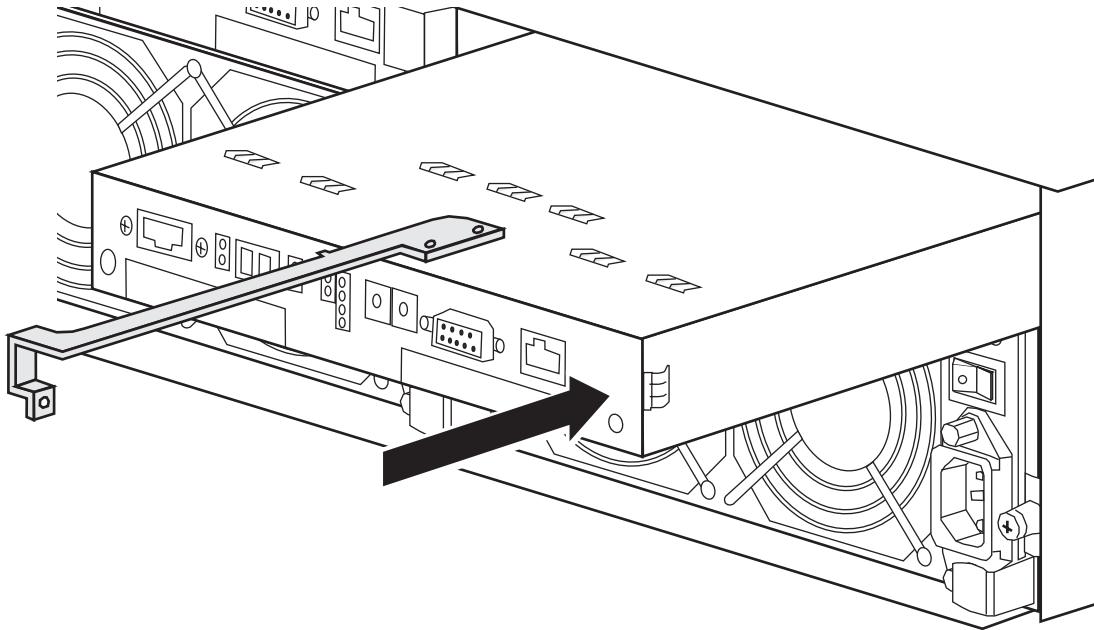

2. With the ejector open, insert the replacement module into the empty bay. Make sure the module is seated.

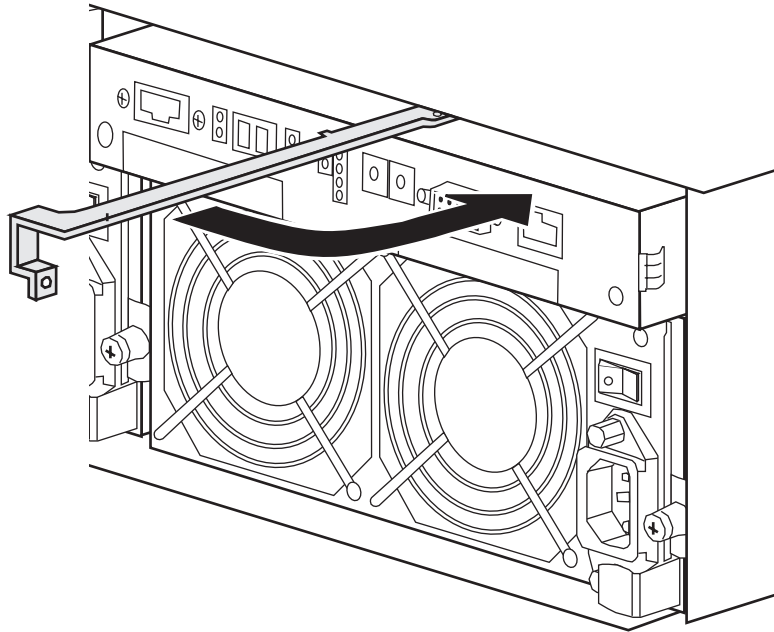

3. Close the ejector lever to seat the module.

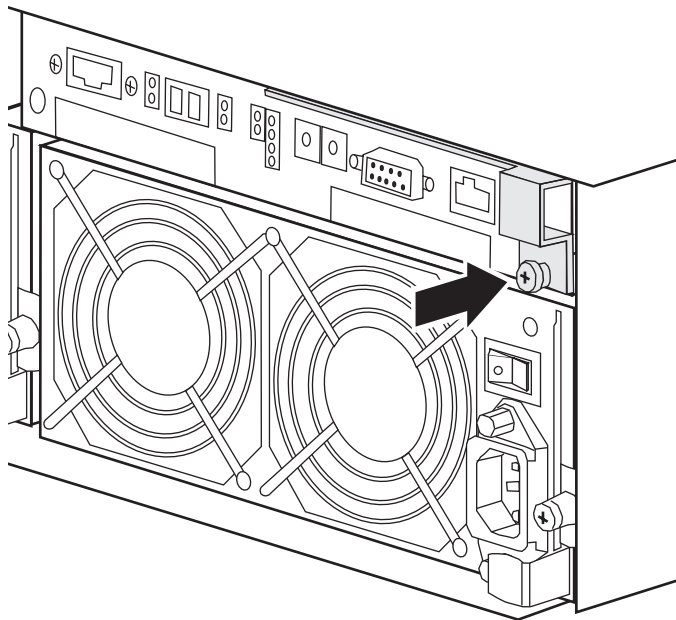

4. Tighten the set screw.

5. Reconnect cabling.

6. Verify RAID controller initialization as displayed by the module's Ready LED. Refer to [“Interpreting controller status LEDs” on page 41](#). If the replacement RAID controller fails to initialize, it may have the wrong microcode version

installed. Refer to Chapter 3, “Working with Storage Using GVG Disk Utility”, in the *Profile XP System Guide* for information on checking and loading controller firmware.

7. Check RAID controller status using NetCentral or GVG Disk Utility. If required, update the firmware to match the version on the other RAID controller using GVG Disk Utility.

Replacing the LAN card

1. Remove the cables connected to the LAN card.

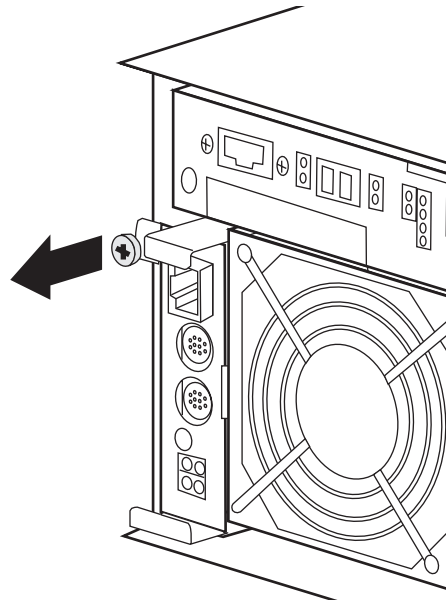

2. Loosen the retaining screw.

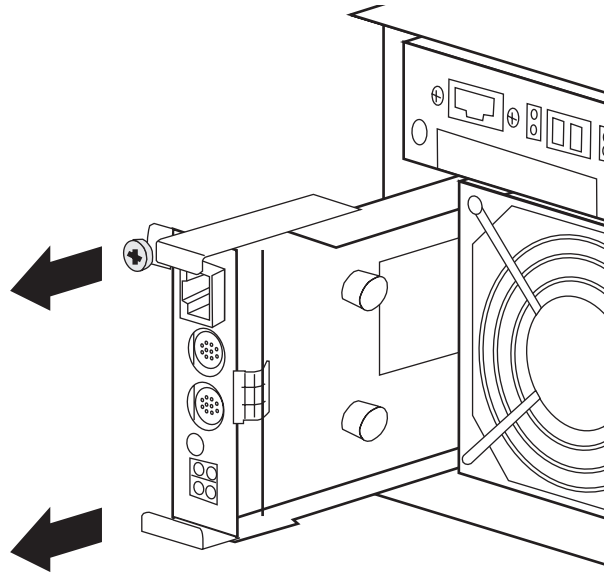

3. Grasp the points as shown and pull out the defective LAN card.

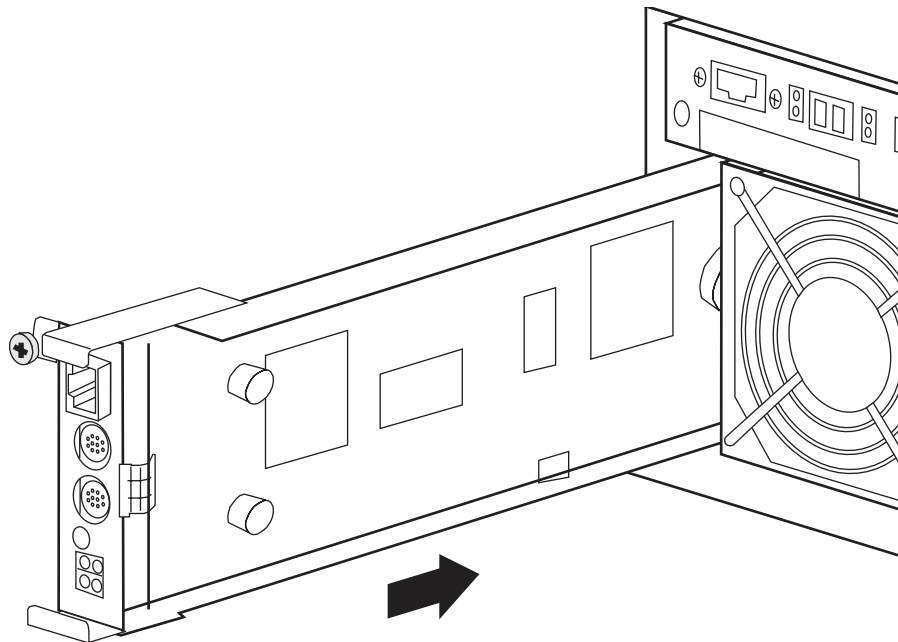

4. Insert the replacement LAN card into the empty bay.

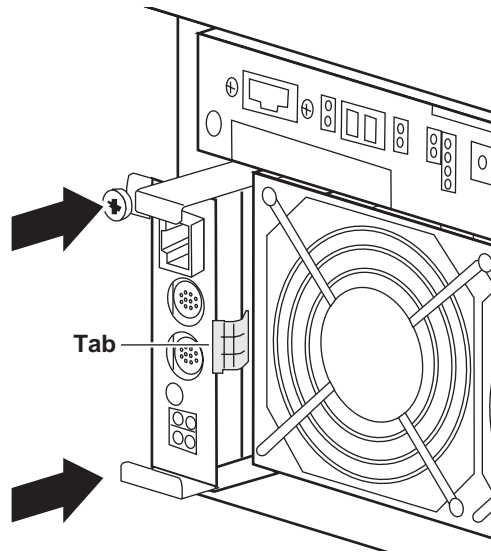

5. When the LAN card's tab is in position for insertion, push the projections at the top and bottom of the LAN card to insert the tab.
6. Tighten the retaining screw.
7. Connect cables.
8. Configure network and SNMP settings for the RAID chassis as described in the *PVS Installation Guide*.

Replacing a power supply



NOTE: Turn off the power supply before unplugging the power cord from the supply or removing the supply from the chassis.

The RAID chassis and the expansion chassis each have their own type of power supply. The two types are not interchangeable.

Make sure the correct type of replacement power supply is on hand and you are otherwise prepared to complete the procedure in less than five minutes. If the time exceeds five minutes, the protective feature of the RAID chassis triggers a shutdown sequence.

To replace the power supply:

1. Identify the faulty power supply by verifying that its Fault LED is on.
2. Turn off the power switch on the faulty power supply.

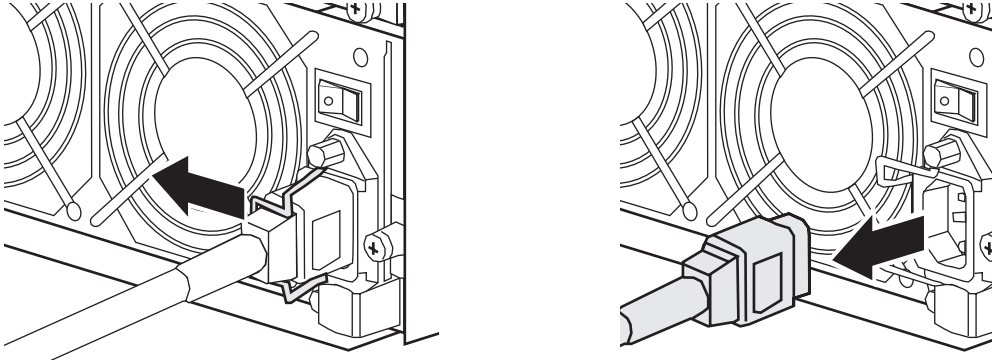

3. Unlatch the stopper to release and unplug the power cord.

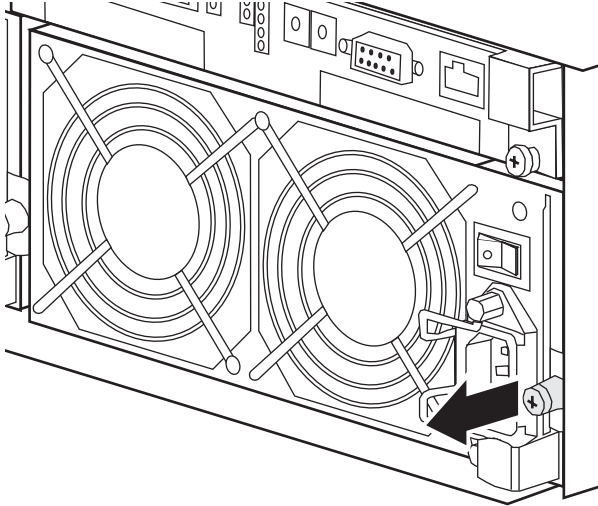

4. Loosen the set screw on the ejector.

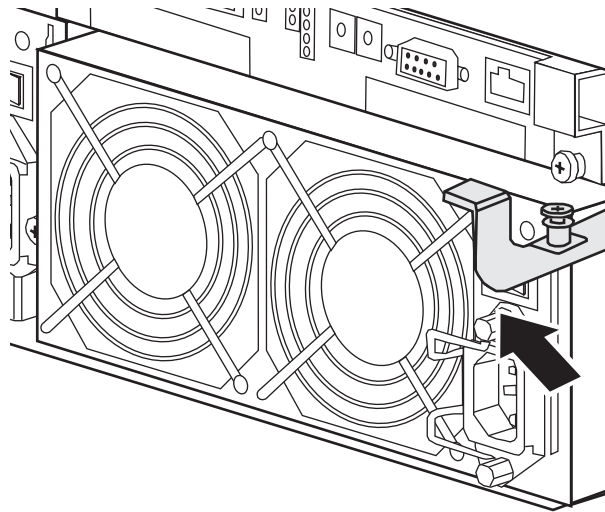

5. Pull the ejector out and up to 90 degrees.

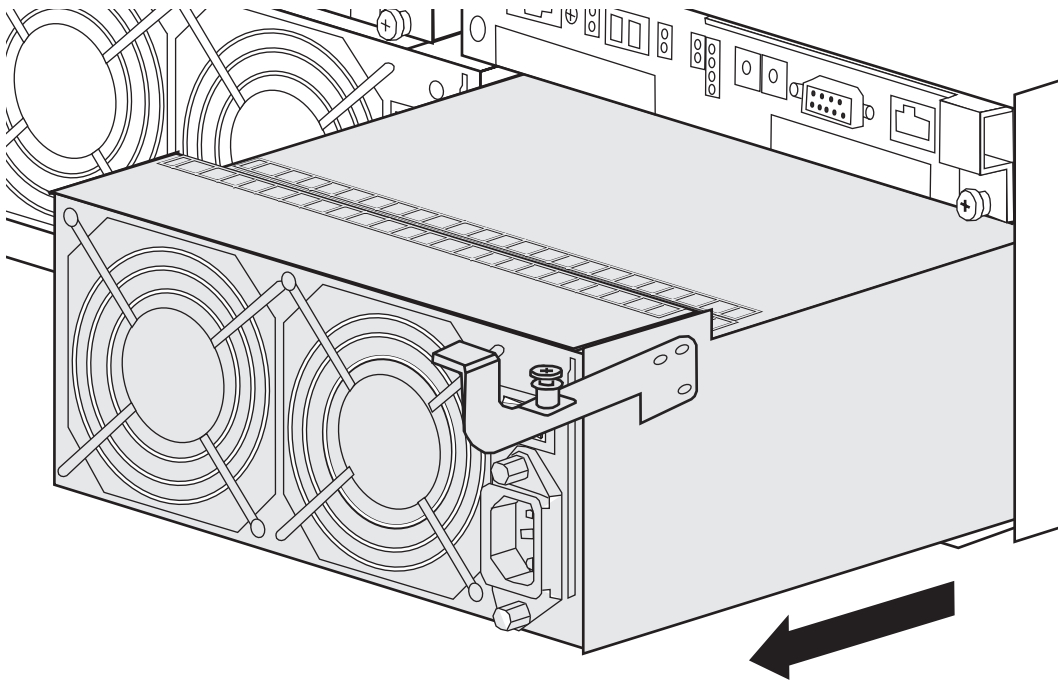

6. Slide the power supply out.

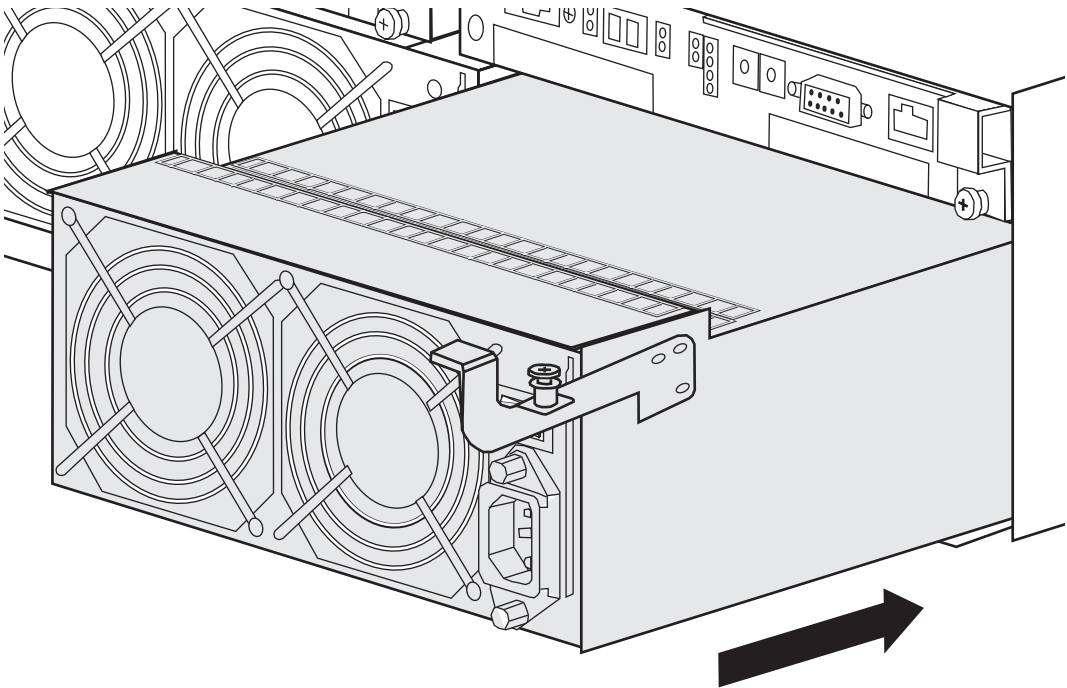

7. With the ejector open, insert the replacement power supply into the empty bay.

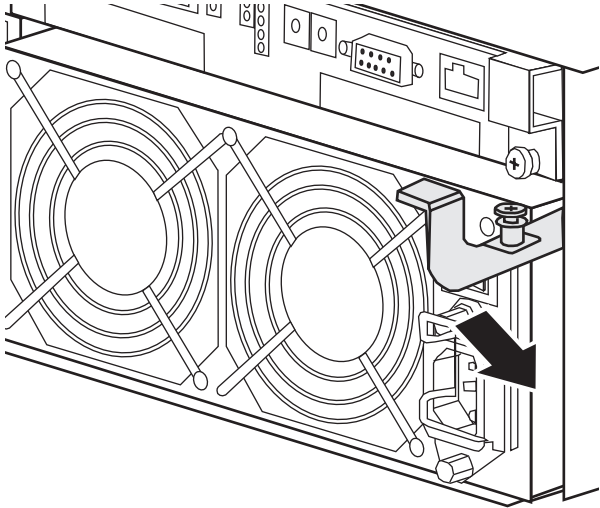

8. Push the protrusion of the ejector to turn the ejector and push in the new power supply.

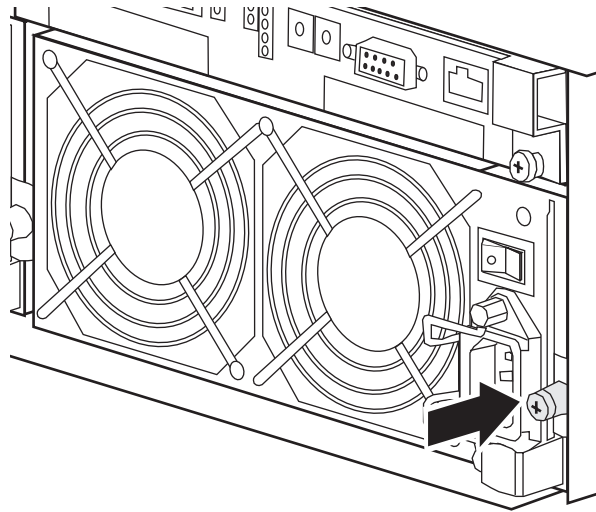

9. Secure the ejector with the screw.

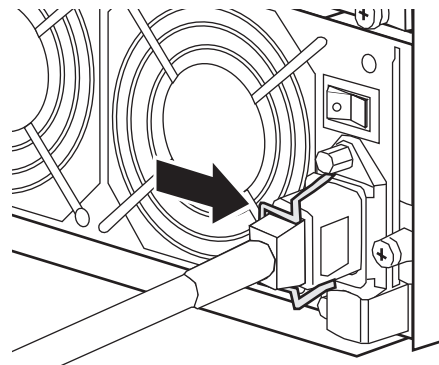
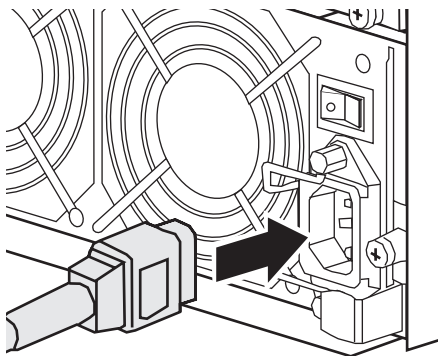

10. Plug the power cord in the new power supply and secure the power cord by firmly fitting the removal protection mechanism.

11. Turn on the power switch.

12. Check that the Good LED of the new power supply is on.

13. Monitor the status of the power supply using NetCentral.

PFR700 Series Technical Specifications and Operating Limits

AC power requirements

Item	Measurement
Input voltage	100 to 240 VAC \pm 10% (\times 2), 50/60 Hz
Maximum power consumption ^a	550 VA Expansion chassis: 520 VA

^a While the chassis can accept power of 100 - 240 VAC (50/60 Hz), the included power cord can only accept 100 VAC. Use 100 VAC (50/60 Hz) when the included power cord is used.

If one of the two power supplies fails, the remaining supply and cord must support the full load. Your rackmount cabinet must include AC power distribution that can handle these values.

Size and weight

Item	Measurement
Height	131 mm (5.16 in) (3 rack units)
Width	482 mm (19 in)
Depth	594 mm (23.4 in) including front cover
Weight	Approx. 45 kg (99 lbs) with maximum configuration

Cable lengths

It is recommended that you use the Fibre Channel cables shipped with your PFR700/E when making connections.

Optical cables must meet the appropriate standards for 2-Gb/s FC-AL loops. Such cables are duplex LC cables with lengths up to 300m on 50/125 μ m MMF, or up to 150m on 62.5/125 μ m MMF.

Copper cables are used to connect the RAID chassis with the expansion chassis. Copper cables must meet the appropriate standards for 1-Gbit FC-AL loops. Such cables are fully shielded, twin-axial, full-duplex cables. Cables greater than 10 meters must be equalized; cables equal to or less than 10 meters do not need to be equalized. Do not use copper cables longer than 2 meters.

Environmental limits

The system includes two temperature level sensors used to issue auto-warning and auto-shutdown in case the over temperature limit is reached.

Environmental condition	Operating	Halting ^a
Ambient temperature	5°C to 40°C (41°F to 104°F)	-10°C to 60°C (14°F to 140°F)
Relative humidity	10% to 80%	10% to 80%
Wet-bulb temperature ^b	0°C to 27°C (32°F to 81°F)	-8°C to 29°C (18°F to 84°F)
Allowable vibration level	0.25 G	0.5 G

^a. The halting status includes the packaged status in shipping carton and the storage status.

^b. Without condensation

Life expectancies of components

Item	Measurement
Battery	2.5 years
Fan (power supply)	50,000 hours

Glossary

The terms and definitions listed below are related to the storage system described in this manual. Understanding them will aid your understanding of the storage system.

ALPA (arbitrated loop physical address)

An 8-bit address that uniquely identifies a device on an FC loop.

bind

In the context of a disk-array storage system, the procedure by which you hardware-format one or more disk modules into one LUN (logical unit) - usually as one of several types of RAID group.

BTU (British Thermal Unit)

A standard measure of a device's heat output.

cache

See storage-system caching.

CA (chassis address)

A number, set to 0 on a RAID chassis, that helps establish a unique address for each disk module on an FC-AL loop. You must set the CA on each RAID Expansion Chassis. Since the RAID chassis CA is 0, set the Expansion Chassis CA to 1.

disk-drive module

Another name for disk module.

disk unit

A short name for physical disk unit.

disk module

A self-contained disk drive that slides into one of the slots in the front of the storage system. It consists of the carrier assembly, which holds the disk drive and the regulator board. Also called disk-drive module.

DIMM (dual in-line memory module)

A type of memory module used in RC memory for write caching or RAID 3 memory.

EMI (electromagnetic interference)

Electronic radiation emitted by an electrical device. The levels of EMI are strictly controlled for data processing equipment. The EMI standards are explained after the Notice page near the beginning of the manual.

ESD (electrostatic discharge)

The discharge of an accumulated electrical charge (static). This can severely damage delicate electronic circuits and you should take steps to prevent this, as explained in the Chapter 3, "Servicing the PFR 600 Series RAID".

FC-AL (Fibre Channel arbitrated loop)

An arrangement of Fibre Channel stations such that messages pass from one to the next in a ring.

FC-AL address ID

A number that identifies a device as a node on a fibre channel loop. You select the FC-AL address ID using switches on the RAID controller.

Fibre Channel Disk board

The name for the printed-circuit board within the Profile XP Media Platform that allows the server to access the Fibre Channel loop and thence the disk drives within a PFR 700/E.

field-replaceable unit

See FRU (field-replaceable unit).

FRU (field-replaceable unit)

A hardware assembly that can be replaced on site, instead of at the point of manufacture.

hot repair

See replace under power.

hub

An FC_AL switching device that allows multiple servers and targets such as storage systems to connect at a central point. A single hub configuration appears as a single loop.

LUN (logical unit)

One or more disk modules (each having a head assembly and spindle) bound into a group - usually a RAID group. The operating system sees the LUN, which includes one or more disk modules, as one contiguous span of disk space.

memory module

See RC memory module.

node

Any device with a Fibre Channel interface that connects to a Fibre Channel loop.

power supply

An essential element of the storage-system power supply. A storage system can have two power supplies. With two, it can survive failure of one supply. You can replace a power supply under power, without interrupting applications.

PFR 700 RAID Storage Chassis

A storage system that includes a chassis, up to 15 disk modules, one or two RAID controllers, one LAN card, and one or two power supplies. A PFR 700 can support one PFR 700E RAID Expansion Chassis (with up to 15 disk modules) in addition to its own 15 disk modules, for a total of 30 disk modules.

PFR 700E RAID Expansion Chassis

A storage system that includes a chassis, up to 15 disk modules, one or two expansion adapters, and one or two power supplies.

PLDA (private loop direct attach) profile

A standard for FC-AL disk drives.

RAID controller (RC)

See RC (RAID controller).

RC (RAID controller)

A printed-circuit board with memory modules and control logic that manages the storage-system I/O between the Profile XP Media Platform FC adapter and the disk modules. For higher availability, a PFR 700 can use a second RC.

RC memory module

A memory module (DIMM or SIMM) that provides the local storage for an RC.

replace under power

The storage system provides replace under power capability, allowing you to replace, for example, a disk module or a power supply module without powering down the storage system. Applications continue while you replace the failed module.

SCSI (small computer system interface)

A well-known protocol and standard for connecting computers and peripheral devices.

SES (SCSI enclosure services)

A functional subset of SCSI III commands that allow a server to communicate with storage enclosures using their disk modules.

SFF

Small Form Factor Committee

server

In the context of storage systems, a processor that runs an operating system and uses a disk-array storage system for data storage and retrieval.

storage chassis

A storage device that includes a chassis, up to 15 disk modules, one or two RAID controllers, one LAN card, and one or two power supplies.

storage-system caching

The procedure of storing disk-based data in RAM memory (in this case, DIMM memory on an RC) temporarily to save time if the data needs to be accessed or changed again soon.

Index

A

- AC power
 - current draw 59
 - overview 23
- address ID
 - FC-AL (Fibre Channel Arbitrated Loop)
 - setting 26
- address switch, chassis 27

B

- battery
 - life expectancy 60
 - replacement 6
- Battery Backup Unit 17
- binding disk modules 29
- blinking disk module LEDs 39

C

- cabling
 - max lengths 28
 - requirements 28
- Canadian Certified Power Cords 7
- Canadian EMC Notice of Compliance 8
- capacity 16
- certifications and compliances 7
- chassis
 - address switch 27
 - description 17
 - dimensions 59
 - weight 59
- circuit boards
 - description 20
- colors, disk module LEDs 39
- components 16
 - See FRUs (field replaceable units)
- configurations 22
- controller
 - status LEDs 41

D

- depth, chassis 59
- disk module
 - description 18
 - disk module LED colors 39
 - identification 18

- installing 47
- removing 46
- disk module LED displays, interpreting 39
- disk utility 29

E

- ejector lever 49
- electric shock 5
- EN55022 Class A Warning 8
- Ethernet connector 20
- expansion adapter
 - description 20
 - replacing 48

F

- fan
 - life expectancy 60
- FC-AL (Fibre Channel Arbitrated Loop)
 - cabling requirements 28
- FCC Emission Control and Limits 7
- features 15
- field replaceable units (see FRUs)
- fire hazard 5
- flashing disk module LEDs 39
- FRUs (field-replaceable units)
 - disk module
 - description 18
 - replacing 46
 - expansion adapter
 - description 20
 - replacing 48
- LAN card
 - description 20
 - replacing 52
- power supply
 - description 21
 - replacing 54
- RAID Controller
 - description 19
 - replacing 48

G

- grounding
 - safety 5

H

height, chassis 59
high availability features 16

I

injury precautions 5
installing
 disk module 47
 PFR 700/E 30

L

Laser 8
Laser Compliance 8
LEDs
 disk modules 39
 rear panel 41, 43, 44, 45
life expectancies of components 60
loose cable 28

M

midplane board
 description 18

N

NetCentral 38

P

packaging 30
PFR 700/E
 chassis
 midplane 18
 chassis depth 59
 components 16
 configurations 22
 description 16
 disk module description 18
 high availability features 16
 installation requirements 23
 installing in rack 33
 monitoring status 38
 operating limits 60
 power supply, description 21
 powering down 36
 rear panel view 19, 20
 requirements
 cabling 28

 operating 60
 weight 59
power
 cord 35
 outlet 35
power supply
 description 21
 LEDs 45
 replacing 54
powering-up 35
product damage precautions 5

R

rack mounting 30
RAID configuration 29
RAID Controller
 description 19
 replacing 48
 status LEDs 41
remote monitoring 38
replacing
 disk module 45
 expansion adapter 48
 LAN card 52
 power supply 54

S

safety certification 9
safety ground 35
safety summary 5
safety terms and symbols 6
service safety summary 7
site requirements
 see also Appendix A
size and weight 59
SNMP monitoring 38
standby switch 54
status
 monitoring PFR 700/E 38
storage capacity 16
support, Grass Valley 14

V

ventilation 5
voltage, PFR 700/E requirements 59

W

weight, chassis 59

width, chassis 59

